



HP ProCurve 6600 Switches

Installation and Getting Started Guide

ProCurve 6600 Switches

Installation and Getting Started Guide

Publication Number

5992-4962
August 2011

Applicable Products

HP ProCurve 6600-24G Switch	(J9263A)
HP ProCurve 6600-24G-4XG Switch	(J9264A)
HP ProCurve 6600-24G-24XG Switch	(J9265A)
HP ProCurve 6600-48G Switch	(J9451A)
HP ProCurve 6600-48G-4XG Switch	(J9452A)
HP ProCurve Switch Power Supply	(J9269A)
HP ProCurve Switch Fan Tray	(J9271A)

Disclaimer

HEWLETT-PACKARD COMPANY MAKES NO WARRANTY OF ANY KIND WITH REGARD TO THIS MATERIAL, INCLUDING, BUT NOT LIMITED TO, THE IMPLIED WARRANTIES OF MERCHANTABILITY AND FITNESS FOR A PARTICULAR PURPOSE. Hewlett-Packard shall not be liable for errors contained herein or for incidental or consequential damages in connection with the furnishing, performance, or use of this material.

The information contained herein is subject to change without notice. The only warranties for HP products and services are set forth in the express warranty statements accompanying such products and services. Nothing herein should be construed as constituting an additional warranty. HP shall not be liable for technical or editorial errors or omissions contained herein.

Hewlett-Packard assumes no responsibility for the use or reliability of its software on equipment that is not furnished by Hewlett-Packard.

Warranty

See the Customer Support/Warranty booklet included with the product.

A copy of the specific warranty terms applicable to your Hewlett-Packard products and replacement parts can be obtained from your HP Sales and Service Office or authorized dealer.

Safety

Before installing and operating these products, please read the "Installation Precautions" in chapter 2, "Installing the Switch", and the safety statements in appendix C, "Safety and EMC Regulatory Statements".

Contents

Introducing the Switch

Front of the Switch	1-4
Network Ports	1-6
LEDs	1-7
LED Mode Select Button and Indicator LEDs	1-9
Reset Button	1-11
Clear Button	1-11
Console Port	1-11
Back of the Switch	1-12
Power Connector	1-12
Switch Features	1-13

Installing the Switch

Included Parts	2-1
Installation Precautions	2-3
Installation Procedures	2-4
Overview	2-4
1. Prepare the Installation Site	2-5
2. Verify the Switch Passes Self-Test	2-5
LED Behavior During Self-Test	2-7
3. (Optional) Reverse the air flow	2-8
4. Mount the Switch and Route the Power Cords	2-11
Rack or Cabinet Mounting	2-11
Mounting a 6600 Switch with the 4-Post Rack Mount Kit	2-12
Mounting a 6600 Switch in an HP 10000 Series Cabinet	2-16
Mounting the Switch in a 2-Post Telco Rack	2-22
5. Connect the Switch to a Power Source	2-24
6. (Optional) Install Transceivers	2-24
Installing a Transceiver	2-25
Removing a Transceiver	2-26
7. Connect the Network Cables	2-27
Using the RJ-45 Connectors	2-27
Connecting Cables to Transceivers	2-27

8. (Optional) Connect a Management Console	2-28
Configuring the Management Console	2-29
Setting Up an Out-of-Band Console Connection	2-29
Sample Network Topology	2-32

Getting Started With Switch Configuration

Recommended Minimal Configuration	3-1
Minimal Configuration Through the Out-of-Band Console Connection ..	3-2
Where to Go From Here: Networked Connections	3-4
Using the IP Address for Remote Switch Management	3-6
Starting a Telnet Session	3-6
Starting a Web Browser Session	3-6

Replacing Components

Replacing the Fan Tray	4-1
Replacing a Power Supply	4-3

Troubleshooting

Basic Troubleshooting Tips	5-1
Using LEDs to Diagnose an Error Condition	5-4
Proactive Networking	5-8
Hardware Diagnostic Tests	5-9
Testing the Switch by Resetting It	5-9
Checking the Switch LEDs	5-9
Checking Console Messages	5-9
Testing Twisted-Pair Cabling	5-10
Testing Switch-to-Device Network Communications	5-10
Testing End-to-End Network Communications	5-10
Restoring the Factory Default Configuration	5-11
Downloading New Switch Software	5-12
HP Customer Support Services	5-12
Before Calling Support	5-12

Specifications

Physical	A-1
Electrical	A-1
Environmental	A-1
Acoustic	A-2
Safety	A-3

Cabling and Technology Information

Cabling specifications	B-1
Technology distance specifications	B-3
Mode Conditioning Patch Cord	B-4
Installing the Patch Cord	B-5
Twisted-Pair Cable/Connector Pin-Outs	B-6
Straight-Through Twisted-Pair Cable for 10 Mbps or 100 Mbps Network Connections	B-7
Cable Diagram	B-7
Pin Assignments	B-7
Crossover Twisted-Pair Cable for 10 Mbps or 100 Mbps Network Connection	B-8
Cable Diagram	B-8
Pin Assignments	B-8
Straight-Through Twisted-Pair Cable for 1000 Mbps Network Connections	B-9
Cable Diagram	B-9
Pin Assignments	B-9

Safety and EMC Regulatory Statements

Safety Information	C-1
Informations concernant la sécurité	C-2
Hinweise zur Sicherheit	C-3
Considerazioni sulla sicurezza	C-4
Consideraciones sobre seguridad	C-5
Safety Information (Japan)	C-6
Safety Information (China)	C-7

EMC Regulatory Statements	C-8
U.S.A.	C-8
Canada	C-8
Australia/New Zealand	C-8
Japan	C-8
Taiwan	C-8
European Community	C-9

Recycle Statements

Waste Electrical and Electronic Equipment (WEEE) Statements	D-1
---	-----

Index

Introducing the Switch

HP ProCurve 6600 Switches are top-of-rack data center switches that support advanced Layer 3 switching, and have reversible front-to-back airflow and two hot swappable power supplies. You can use 6600 Switches to build high-speed switched networks between servers in the data center.

HP ProCurve 6600-24G Switch (J9263A)



- 20 auto-sensing 10/100/1000Base-TX RJ-45 ports
- 4 dual-personality ports: auto-sensing 10/100/1000Base-T RJ-45 or Small Form-Factor Pluggable (SFP) that accept mini-GBIC transceivers

HP ProCurve 6600-24G-4XG Switch (J9264A)



- 20 auto-sensing 10/100/1000Base-TX RJ-45 ports
- 4 dual-personality ports that can function as auto-sensing 10/100/1000Base-T RJ-45 or SFP (mini-GBIC) ports
- 4 SFP+ ports that accept 10-Gigabit transceivers

Note

Although SFP+ ports are the same form-factor (size and shape) as SFP ports, SFP+ ports support 10-Gigabit transceivers while SFP ports support 1-Gigabit and 100-Megabit transceivers.

HP ProCurve 6600-24XG Switch (J9265A)



- 24 SFP+ ports for 10-Gigabit connectivity

HP ProCurve 6600-48G Switch (J9451A)



- 44 auto-sensing 10/100/1000Base-TX RJ-45 ports
- 4 dual-personality ports that can function as auto-sensing 10/100/1000Base-T RJ-45 or SFP (mini-GBIC) ports

HP ProCurve 6600-48G-4XG Switch (J9452A)



- 48 auto-sensing 10/100/1000Base-TX RJ-45 ports
- 4 SFP+ ports for 10-Gigabit connectivity

6600 Switches support optional network connectivity with the speeds and technologies shown in Table 1-1 .

Table 1-1. Transceiver Speeds and Technologies

Speed	Technology	Cabling	Transceiver Form-Factor and Connector	
			SFP(mini-GBIC) Connector	SFP+ Connector
100-Mbps	100-FX	Fiber (multimode)	LC	
	100-BX	Fiber (single mode)	LC	
1-Gbps	1000-SX	Fiber (multimode)	LC	
	1000-LX	Fiber (multimode or single mode)	LC	
	1000-LH	Fiber (single mode)	LC	
	1000-BX	Fiber (single mode)	LC	
10-Gbps	10-Gig Direct Attach	Copper (Twinaxial)		N/A ¹
	10-Gig SR	Fiber (multimode)		LC
	10-Gig LRM	Fiber (multimode)		LC
	10-Gig LR	Fiber (single mode)		LC
¹ Direct attach cables (DAC) are low-cost 10-GbE connectivity options consisting of a one, three, or seven meter cable with SFP+ connectors permanently attached to each end.				
For a list of supported transceivers, go to www.procurve.com/faqs . On this web site, ProCurve 10-GbE Transceivers and ProCurve Mini-GBICs and SFPs have links to a list of supported products (first question in the "General Product Information" category).				
For technical details of cabling and technologies see Appendix B, " Cabling and Technology Information ".				

6600 Switches are designed to be used primarily in data center environments while mounted in equipment racks with the servers they are connected to.

6600 Switches can directly connect servers to other servers or backbone LANs to provide dedicated bandwidth to those devices. You can build a switched network infrastructure by interconnecting 6600 Switches with routers or other switches. In addition, 6600 Switches offer full network management capabilities.

Front of the Switch

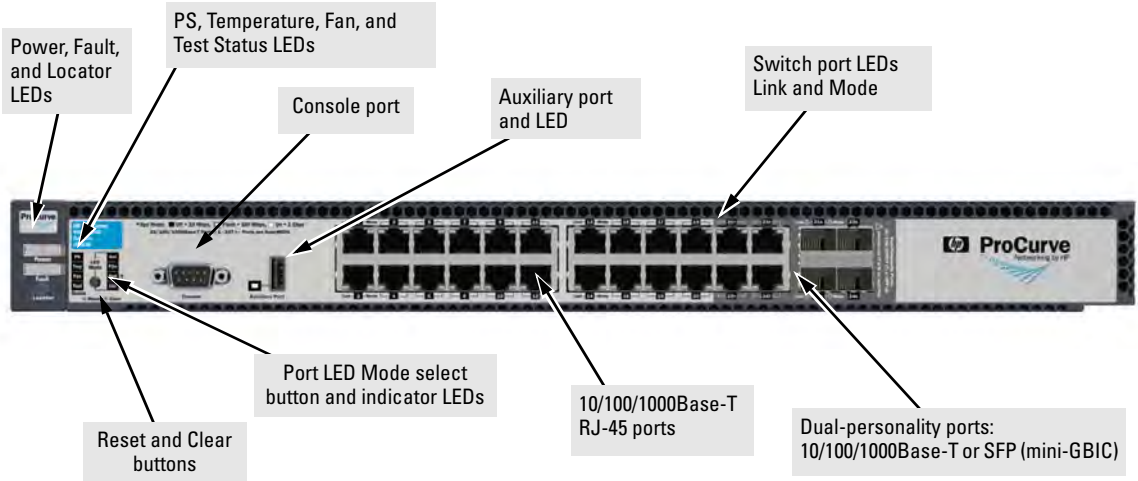
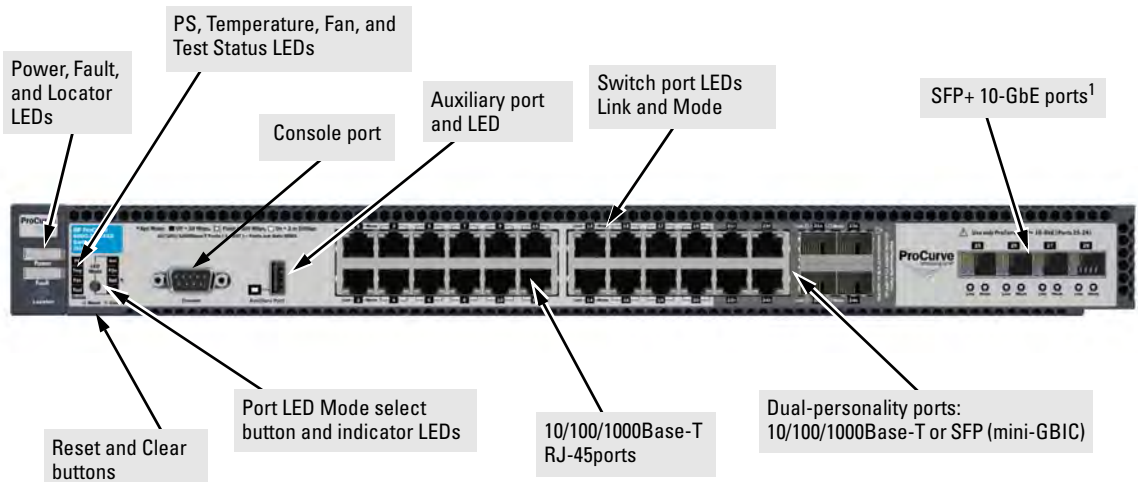

Figure 1-1. HP ProCurve 6600-24G Switch



¹ The SFP+ slots are in the same configuration as the SFP (mini-GBIC) slots of ports 22 and 24. Insert transceivers with the label facing down.

Figure 1-2. HP ProCurve 6600-24G-4XG Switch

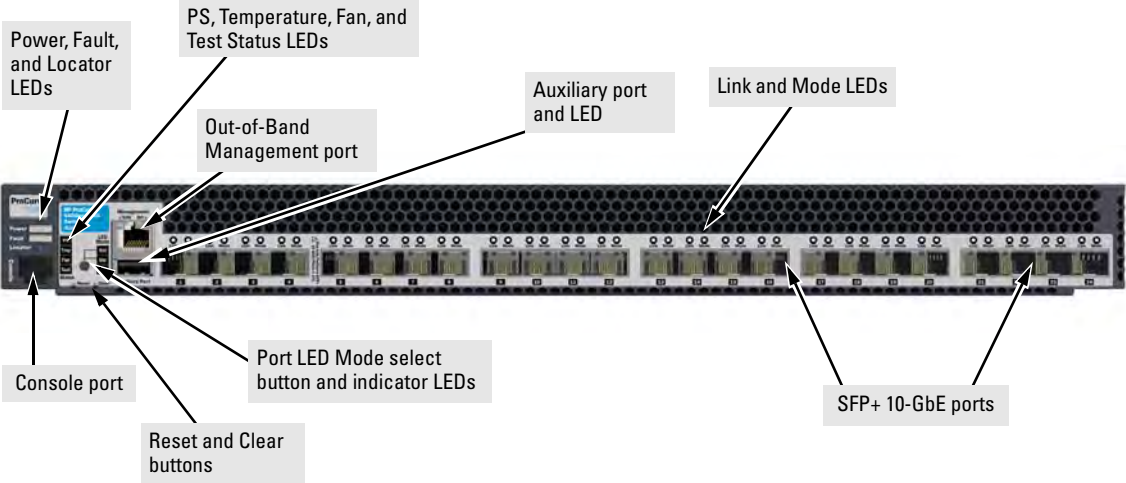

Figure 1-3. HP ProCurve 6600-24XG Switch

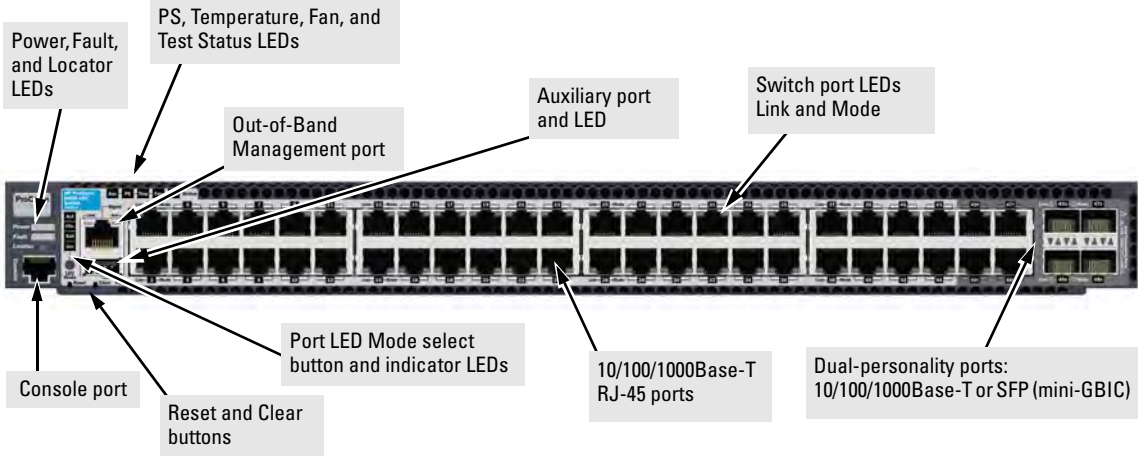

Figure 1-4. HP ProCurve 6600-48G Switch

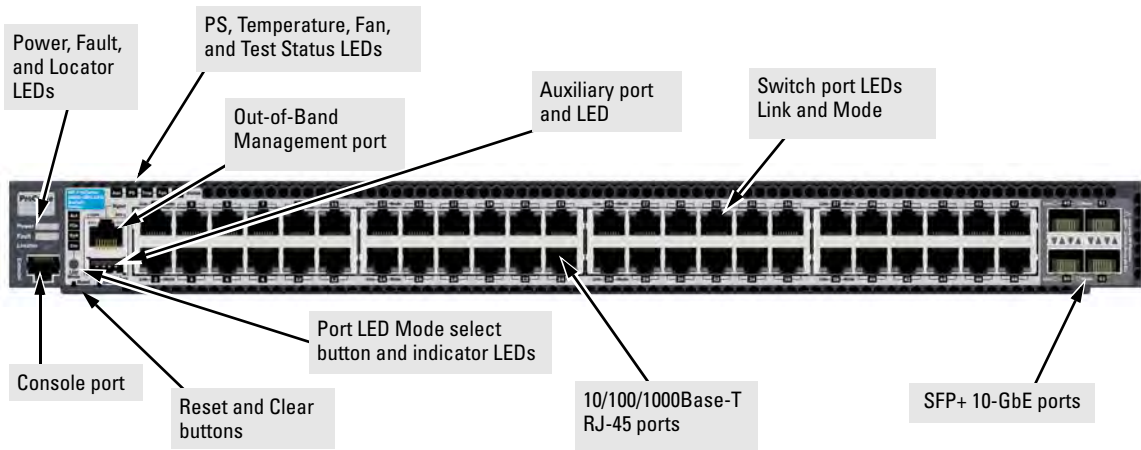

Figure 1-5. HP ProCurve 6600-48G-4XG Switch

Network Ports

- On the 6600-24G, 6600-24G-4XG, 6600-48G, and 6600-48G-4XG Switches, there are 24 or 48 auto-sensing 10/100/1000Base-T ports. These ports support the “Auto MDIX” feature, which allows you to use either straight-through or crossover twisted-pair cables to connect any network device to the switch.
- On the 6600-24G, 6600-48G, 6600-24G-4XG Switches, there are four dual-personality ports, which support the use of a 10/100/1000Base-T RJ-45 connector or an HP ProCurve SFP (mini-GBIC) transceiver for fiber-optic connections.
Dual-Personality Port Operation. By default, the RJ-45 connectors are enabled. However, if you install an SFP transceiver in the slot, the transceiver is enabled and the associated RJ-45 connector is disabled and cannot be used. When you remove the SFP transceiver, the associated RJ-45 port is automatically re-enabled.
- The 6600-24XG Switch has twenty-four SFP+ ports; the 6600-48G-4XG and 6600-24G-4XG Switches have four SFP+ ports. An SFP+ port supports only 10 Gbps operation. SFP transceivers are not supported on an SFP+ port.

LEDs

Table 1-2 describes each LED state. For more information, refer to the *Management and Configuration Guide* for your switch.

Table 1-2. Switch LEDs

Switch LEDs	State	Meaning
Power (Green)	On	Switch power is operating correctly.
	Off	Switch power is not operating correctly or there is no power connection.
Fault (Orange)	Off	The normal state; indicates there are no fault conditions on the switch.
	Blinking ¹	A fault has occurred on the switch, one of the switch ports, module in the rear of the switch, or the fan. The Status LED for the component with the Fault LED will blink simultaneously.
	On	On briefly after the switch is powered on or reset, at the beginning of switch self-test. If this LED is on for a prolonged time, the switch has encountered a fatal hardware failure, or has failed its self-test. See chapter 4, "Troubleshooting" for more information.
Locator (Blue)	On	The Locator LED is used to locate a specific switch in a area full of switches. The LED can be set to be on solid or blink for a specified number of minutes (1-1440). The default is 30 minutes. Use the command "chassislocate".
	Blinking	
	Off	
PS (Green/Orange)	On green	The switch is receiving power.
	Off	The switch is NOT receiving power.
	Blinking orange ¹	A fault has occurred on one of the power supplies. The PS Status LED, Fault LED, and on the back of the switch the failed power supply LED (PS1 or PS2) will all blink simultaneously.
Tmp (Green/Orange)	On green	Switch temperature is normal.
	Blinking orange ¹	An over temperature condition has been detected. This is a Fault condition indicating elevated internal temperatures. The Fault LED will blink simultaneously. This indicates an alert condition indicating critical internal temperatures. The Fault LED will blink simultaneously.
	Blinking orange ²	
	Blinking orange ²	
Fan Status (Green/Orange)	On	Normal operation, all fans are ok.
	Blinking orange ¹	One of the unit's fans has failed. The switch Fault LED will be blinking simultaneously.
	Blinking orange ²	One of the unit's fans has failed and the switch is in an overtemp condition. The switch Fault LED will be blinking simultaneously.
Fan LED on the fan tray (Orange)	Off	Normal operation, all fans are working properly.
	Blinking orange ¹	One or more of the unit's fans has failed. The switch Fault LED, fan status LED on the front of the switch, and the fan status LED on the back of the switch will be blinking simultaneously.

Switch LEDs	State	Meaning
Test (Green/Orange)	Off	The normal operational state; the switch is not undergoing self-test.
	On green	The switch self-test and initialization are in progress after the switch has been power cycled or reset. The switch is not operational until this LED goes off. The Self-Test LED also comes on briefly when you “hot swap” a transceiver into the switch; the transceiver is self-tested when it is hot swapped.
	Blinking orange ¹	A component of the switch has failed its self-test. The status LED for that component, for example an RJ-45 port, and the switch Fault LED will blink simultaneously.
Port LEDs (Green/Orange – Link and Mode)	Link	Indicates the port LEDs are displaying link information: <ul style="list-style-type: none"> if the port LED is on, the port is enabled and receiving a link indication from the connected device. if the port LED is off, the port has no active network cable connected, or is not receiving link beat or sufficient light. Otherwise, the port may have been disabled through the switch console, the web browser interface, or ProCurve Manager. if the port LED is Blinking ¹ (orange) simultaneously with the Fault LED, the corresponding port has failed its self-test.
	Mode	The operation of the Mode LED is controlled by the LED Mode select button, and the current setting is indicated by the LED Mode indicator LEDs near the button. Press the button to step from one view mode to the next. The default view is Activity (Act).
LED Mode View (Green LEDs)	Act	Indicates the port LEDs are displaying network activity information.
	FDx	Indicates port LEDs are lit for ports in Full Duplex Mode. Off indicates ½ duplex.
	Spd	Indicates the port LEDs are displaying the connection speed at which each port is operating: <ul style="list-style-type: none"> if the port LED is off, the port is operating at 10 Mbps. if the port LED is Blinking**, the port is operating at 100 Mbps. if the port LED is on continuously, the port is operating at 1000 Mbps.
	Usr	Indicates the port is displaying customer-specified information.

Switch LEDs	State	Meaning
Auxiliary (Green/Orange)	Blinking green ²	Data transfer between the switch and a USB device is occurring.
	On green	USB device is connected to the switch. No data transfer operation is occurring.
	Blinking orange ¹	Indicates an error condition. The switch Fault LED will be blinking simultaneously. There is a hardware fault associated with the USB device or the USB connector on the switch.
	Blinking orange ²	Indicates an alert condition. The switch Fault LED should not be blinking simultaneously. An alert error occurred in the USB operation that is not caused by a hardware fault, such as a file transfer error.
	Off	Indicates that no USB device has been inserted, or that the inserted USB device cannot be recognized, or that no command file can be found on the inserted USB device.
¹ The Blinking behavior is an on/off cycle once every 1.6 seconds, approximately. ² The Blinking behavior is an on/off cycle once every 0.8 seconds, approximately.		

LED Mode Select Button and Indicator LEDs

The operation of the Mode LED is controlled by the LED Mode select button, and the current setting is indicated by the LED Mode indicator LEDs near the button. Press the button to step from one view mode to the next.

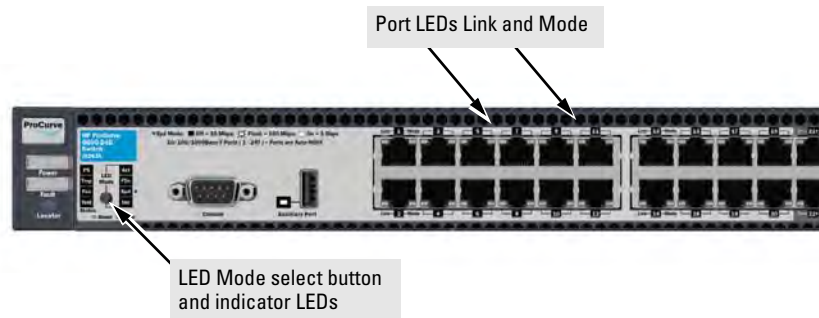

Figure 1-6. HP ProCurve 6600-24G and 6600-24G-4XG Switches

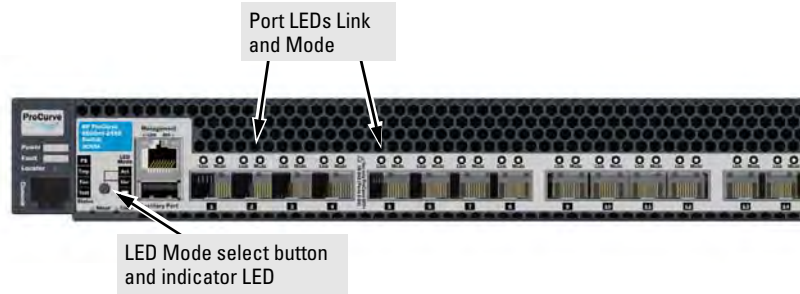

Figure 1-7. HP ProCurve 6600-24XG Switch

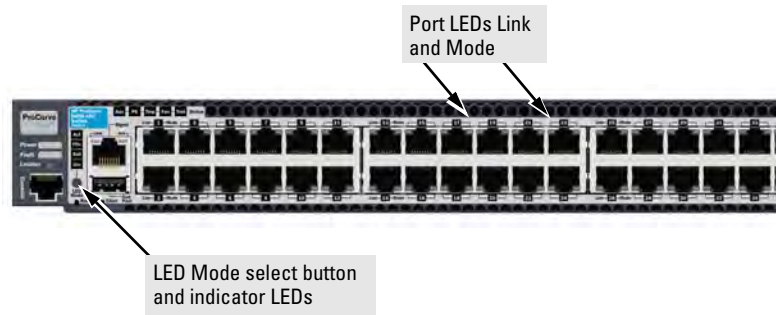

Figure 1-8. HP ProCurve 6600-48G and 6600-48G-4XG Switches

- Each port has a Link LED. If it is lit, the port has a link. If the Link LED is Blinking, the port has failed its self-test. The Fault and Self-Test LEDs will be Blinking simultaneously.
- If the Activity (Act) indicator LED is lit, each port LED displays activity information for the associated port—it flickers as network traffic is received and transmitted through the port.
- If the Full Duplex (FDx) indicator LED is lit, the port LEDs light for those ports that are operating in full duplex.
- If the Speed (Spd) indicator LED is lit, the port LEDs behave as follows to indicate the connection speed for the port:
 - Off = 10 Mbps
 - Blinking = 100 Mbps (the Blinking behavior is a repeated on/off cycle once every 0.8 sec.)
 - On = 1000 Mbps
- The Usr Mode LED indicates the port is displaying customer-specified information.

Reset Button

Use the Reset button to:

- **Reset the switch** - When the switch is powered on. This action clears any temporary error conditions that may have occurred and executes the switch self-test.
- **Restore the factory default configuration** - When pressed with the Clear button in a specific pattern, any configuration changes you may have made through the switch console, the web browser interface, and SNMP management are removed, and the factory default configuration is restored to the switch. For the specific method to restore the factory default configuration, see [“Restoring the Factory Default Configuration” on page 5-11](#), in the Troubleshooting chapter of this manual.

Clear Button

Use the Clear button to:

- **Delete passwords** - When pressed by itself for at least one second, the button deletes any switch console access passwords that you may have configured. Use this feature if you have misplaced the password and need console access. This button is provided as a convenience, however if you are concerned with the security of the switch configuration and operation, you should make sure the switch is installed in a secure location. This button can be disabled by a CLI command.
- **Restore the factory default configuration** - See Reset Button above.

Console Port

The Console port is used to connect a console to the switch in an out-of-band connection by using the RJ-45-to-DB9 cable or DB9-to-DB9 serial cable shipped with the switch. The console can be a PC, a workstation running a VT-100 terminal emulator, or a VT-100 terminal.

6600-24G and 6600-24G-4XG Switches use the DB9-to-DB9 serial cable; 6600-24XG, 6600-48G, and 6600-48G-4XG Switches use the RJ-45 to DB cable.

For more information on the out-of-band console connection, see “8. (Optional) Connect a Management Console” on page 2-28.

Back of the Switch

Figure 1-9 shows the back of an HP ProCurve 6600 Switch, which is the same for all 6600 Switches.

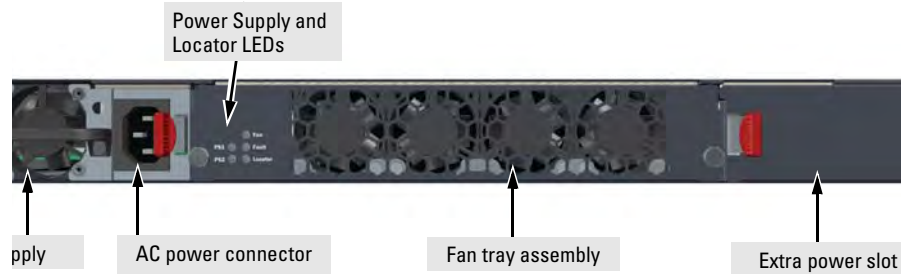

Figure 1-9. Back of an HP ProCurve 6600 Switch

Power Connector

The 6600 Switches do not have a power switch; they are powered on when connected to an active AC power source. These switches automatically adjust to any voltage between 100–127 and 200–240 volts and either 50 or 60 Hz. There are no voltage range settings required.

Switch Features

HP Procurve 6600 Switches have the following hardware and software features:

- Auto-sensing 10/100/1000Base-T RJ-45 ports with Auto-MDIX capability (6600-24G, 6600-24XG-4XG, 6600-48G, and 6600-48G-4XG Switches).

6600-24G, 6600-24G-4XG, 6600-48G, and 6600-48G-4XG Switches support IEEE 802.3ab Auto MDIX on all 10/100/1000 twisted-pair ports. As a result, **all connections can be made using straight-through twisted-pair cables**. Cross-over cables are not required, although they will also work.

The pin operation of each port is automatically adjusted for the attached device: if the switch detects that another switch or hub is connected to the port, it configures the port as MDI; if the switch detects that an end-node device is connected to the port, it configures the port as MDI-X.

- Dual-personality ports, in which an RJ-45 connector or SFP (mini-GBIC) transceiver is supported (6600-24G, 6600-24G-4XG, and 6600-48G Switches).
- SFP+ 10-GbE ports (6600-24XG, 6600-24G-4XG, and 6600-48G-4XG Switches)
- An auxiliary (USB) port for processing a USB command file or copying configuration files and firmware to and from the switch. You can execute an autorun operation for a command file by using a USB flash drive.
- Plug-and-play networking—all ports are enabled—just connect the network cables to active network devices and your switched network is operational.
- Reversible power-to-port air flow—In a 6600 Switch, the default air flow direction is from the power to the port side. In a 4-post rack mounting, you must ensure that the air flow direction is from the cold side to the hot side of the aisle. If necessary, you can reverse the direction of the fans to provide adequate switch cooling.
- Automatic learning of MAC addresses in the address forwarding table; up to 64,000 addresses with a configurable address aging value are supported.
- Automatically negotiated full-duplex operation for the 10/100/1000 RJ-45 ports when connected to other auto-negotiating devices

- Easy management of the switch through several available interfaces:
 - **Command-line interface (CLI)**—a full featured, easy-to-use console interface used from a VT-100 terminal for out-of-band switch management or Telnet access to the switch.
 - **Web browser interface**—an easy-to-use built-in graphical interface that can be accessed from common web browsers.
 - **ProCurve Manager**—an SNMP-based, graphical network management tool that you can use to manage your entire network. This product is included with your new switch.
- Support for the Spanning Tree Protocol to eliminate network loops
- Support for up to 2048 IEEE 802.1Q-compliant VLANs so you can divide the attached end nodes into logical groupings that fit your business needs.
- Support for many advanced features to enhance network performance—for a description, see the *Management and Configuration Guide*, which is on the ProCurve Web site www.procurve.com/manuals.
- Download of new switch software for product enhancements or bug fixes.
- Power Save mode—6600-24XG (J9265A), 6600-48G (J9451A) and 6600-48G-4XG (J9452A) Switches allow you to turn off groups of ports to save power by entering the CLI **savepower** command at the global configuration level.

Ports are grouped into power domains on each 6600 Switch. To enable Power Save mode, you must enter a power domain number with the **savepower** command. The amount of power saved by powering down a port group is shown in the following tables.

6600-24XG Power Save Mode

Power Domain	Port Range	Power Savings
1	01-08	70 watts
2	09-16	70 watts
3	17-24	70 watts

6600-48G Power Save Mode

Power Domain	Port Range	Power Savings
1	01-24	35 watts
2	25-48	35 watts

6600-48G-4XG Power Save Mode

Power Domain	Port Range	Power Savings
1	01-24	35 watts
2	25-48	35 watts
3	49-52*	50 watts
* SFP+ ports for 10-Gigabit Ethernet connectivity		

Note: The Power Save mode configured with the **savepower** command is only a temporary setting, and is not retained after a power cycle or reboot.

For information on the support services provided for 6600 Switches, go to the HP ProCurve Customer Care Services web site at <http://www.procurve.com/customer-care/services/index.htm>.

Installing the Switch

HP ProCurve 6600 Switches come with an accessory kit that includes the brackets for mounting the switch in an equipment cabinet (4-post rack) or a standard 19-inch telco (2-post) rack. The brackets are designed to allow mounting the switch in a variety of locations and orientations. For other mounting options, contact your local ProCurve authorized network reseller or ProCurve representative.

Caution

If the switch is shipped in a rack, be sure to use only an HP 10000 Series rack and mount the switch using the *HP 10000 Series Cabinet: Rack Mount Kit* (5070-0145). Otherwise, the switch warranty may be voided.

Included Parts

6600 Switches are shipped with the following components:

- *HP ProCurve Switch: Quick Setup* sheet
- *HP ProCurve 6600 Switches: Switch Safety and Regulatory Information* sheet
- *HP ProCurve Switches: General Safety and Regulatory Information* booklet
- *Read Me First for HP ProCurve 6600 Switches*
- Customer Support/Warranty booklet
- Accessory kit that contains the following items:
 - Two mounting brackets for a 2-post telco rack
 - Eight M4 (8-mm) screws to attach the mounting brackets to a switch
 - Four 12-24 (5/8-inch) number screws to attach the mounting brackets to a 2-post telco rack
 - Two 10-32 (1/2-inch) screws to attach the mounting brackets to a 4-post rack

Note

To mount a 6600 Switch in a 4-post rack, one of the following accessory kits, which include the mounting brackets for a 4-post rack, is necessary:

- *HP ProCurve 6600 Switch: 4-Post Rack Mount Kit (J9469A)*
- *HP 10000 Series Cabinet: Rack Mount Kit (5070-0145)*

In addition, when you install a 6600 Switch in a 4-post rack with the power side facing the cold aisle, you must also install an air plenum for air circulation. Use the correct plenum for the size of the switch being installed. The plenum comes in two sizes:

- The shorter air plenum (J9480A) is used with 6600-24XG, 6600-48G, and 6600-48G-4XG Switches.
- The longer air plenum (J9481A) is used with 6600-24G and 6600-24G-4XG Switches.

■ Console cable:

- A DB9-to-DB9 console cable and a DB9-to-RJ45 adapter are shipped with the 6600-24G, 6600-24G-4XG Switches.
- A DB9-to-RJ45 console cable is shipped with the 6600-24XG, 6600-48G, and 6600-48G-4XG Switches.

■ Power cord:

Australia/New Zealand	8120-6810
China	8120-8707
Continental Europe	8120-6811
Denmark	8120-6814
Japan	8120-4753
Switzerland	8120-6815
United Kingdom/Hong Kong/Singapore	8120-6809
United States/Canada/Mexico	8120-6812
South Africa	8120-6813
India	8120-6813
Argentina	8120-6869
Thailand	8121-0668
Brazil	8121-1069
Chile	8120-6980
Taiwan	8121-0974
Israel	8121-1035

■ Jumper cable to connect to a Power Distribution Unit (PDU):

United States/Canada/Mexico/Taiwan/Japan	8121-1091
All other countries	8121-1094

Japan Power Cord Warning

製品には、同梱された電源コードをお使い下さい。
同梱された電源コードは、他の製品では使用出来ません。

Installation Precautions

WARNING

- The rack or cabinet should be adequately secured to prevent it from becoming unstable and/or falling over.
- Devices installed in a rack or cabinet should be mounted as low as possible, with the heaviest devices at the bottom and progressively lighter devices installed above.
- Do not wall mount a 6600 Switch.

Cautions

- When you mount a 6600 Switch:
 - In a 2-post telco rack, use the rail mounting brackets and screws in the accessory kit shipped with the switch (5070-6315 or 5070-6316).
 - In an HP 10000 Series cabinet, use the *HP 10000 Series Cabinet: Rack Mount Kit* (5070-0145).
 - In a 4-post equipment rack, use the *HP Procurve 6600 Switch: 4-Post Rack Mount Kit* (J9469A).
- Ensure the power source circuits are properly grounded, then use the power cord supplied with the switch to connect it to the power source.
- If your installation requires a different power cord than the one supplied with the switch and power supply, be sure the cord is adequately sized for the switch's current requirements. In addition, be sure to use a power cord displaying the mark of the safety agency that defines the regulations for power cords in your country. The mark is your assurance that the power cord can be used safely with the switch and power supply.
- When installing the switch, the AC outlet should be near the switch and should be easily accessible in case the switch must be powered off.
- Ensure the switch does not overload the power circuits, wiring, and over-current protection. To determine the possibility of overloading the supply circuits, add together the ampere ratings of all devices installed on the same circuit as the switch and compare the total with the rating limit for the circuit. The maximum ampere ratings are usually printed on the devices near the AC power connectors.
- Do not install the switch in an environment where the operating ambient temperature might exceed 40°C (104°F).
- Ensure the air flow around the front and back of the switch is not restricted. Leave at least 7.6 cm (3 inches) for cooling. See [Figure 2-5](#) for the air flow direction.

Installation Procedures

Overview

1. **Prepare the installation site (page 2-5).** Ensure that the physical environment is properly prepared:
 - Determine the appropriate rack and rail kit for the switch; for example:
 - 2-post telco rack
 - 4-post HP 10000 Series cabinet rack
 - Other 4-post racking solutions such as an equipment cabinet.
 - Have the correct network cabling ready to connect to the switch.
 - Determine the place where you will mount the switch.
 - Follow all installation precautions described in “Cautions” on page 2-3.
2. **Verify that the switch passes self-test (page 2-5).** Plug the switch into a power source and observe that the LEDs on the switch’s front panel indicate correct switch operation. When the self-test is complete, unplug the switch.
3. **(Optional) Reverse the air flow (page 2-8).** The direction of air flow can be reversed from the default (power to port side) direction by reversing the fans.
4. **Mount the switch and route the power cords (page 2-11).** The switch can be mounted in a 2-post telco rack or in a 4-post rack or equipment cabinet.
5. **Connect power to the switch (page 2-24).** Once the switch is mounted, plug it into the nearby main power source.
6. **(Optional) Install SFP (mini-GBIC) or SFP+ transceivers (page 2-24).** The switch has four slots for installing transceivers. Depending on where you mount the switch, it may be easier to install the transceivers first. You can install and remove transceivers while the switch is powered on.
7. **Connect the network cables (page 2-27).** Using the appropriate network cables, connect network devices to the switch ports.
8. **(Optional) Connect a management console to the switch (page 2-28).** You may need to modify the default configuration (such as configure an IP address) to manage a switch using a web browser from an SNMP network management station or through a Telnet session. These configuration changes can be made easily by connecting a PC with the console cable to the switch’s Console port.

The switch is now fully installed. Refer to the appropriate section in this chapter for detailed information on any installation step.

1. Prepare the Installation Site

Cabling Infrastructure - Ensure the cabling infrastructure meets the necessary network requirements. See Appendix B “[Cabling and Technology Information](#)” for detailed information.

Installation Location - Before installing the switch, plan its location and orientation relative to other devices and equipment:

- In the front of the switch, leave at least 7.6 cm (3 inches) of space for the twisted-pair fiber-optic cabling and for cooling. See Figure 2-5 for the air flow direction.
- In the back of the switch, leave at least 3.8 cm (1 1/2 inches) of space for the power cord and cooling.

2. Verify the Switch Passes Self-Test

Before mounting the switch in its network location, you should first verify it is working properly by plugging it into a power source and verifying it passes self-test.

1. Connect the power cord shipped with the switch to the power connector on the back of the power supply, and then into a properly grounded electrical outlet.

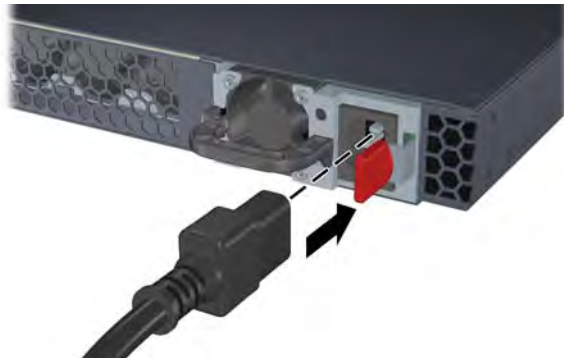

Figure 2-1. Connecting the Power Cord

6600 Switches do not have a power switch. They are powered on when the power cord is connected to the power supply and to a power source. For safety, the power outlet should be located near the switch installation.

The power supply cannot be removed when the power cord is connected.

The switch automatically adjusts to any voltage between 100-127 and 200-240 volts and either 50 or 60 Hz. No voltage range settings are required.

If your installation requires a different power cord than the one supplied with the switch, be sure to use a power cord displaying the mark of the safety agency that defines the regulations for power cords in your country. The mark is your assurance that the power cord can be used safely with the switch.

2. Check the LEDs on the switch as in “LED Behavior During Self-Test” on page 2-7. When the switch is powered on, it performs a diagnostic self-test. The self-test takes approximately 50 seconds to complete.

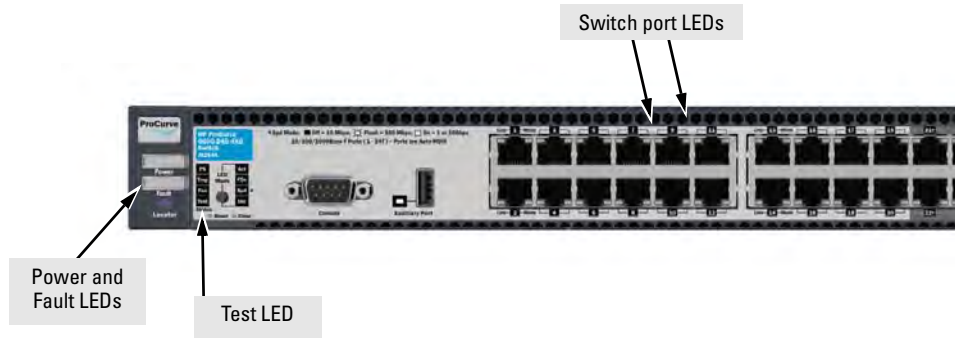

Figure 2-2. Checking the LEDs on the 6600-24G and 6600-24G-4XG

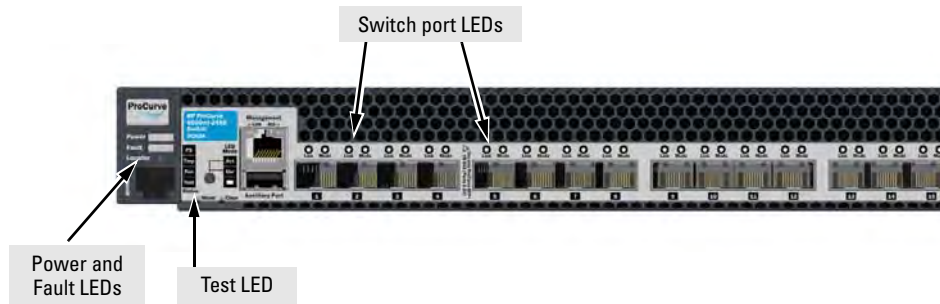

Figure 2-3. Checking the LEDs on the 6600-24XG

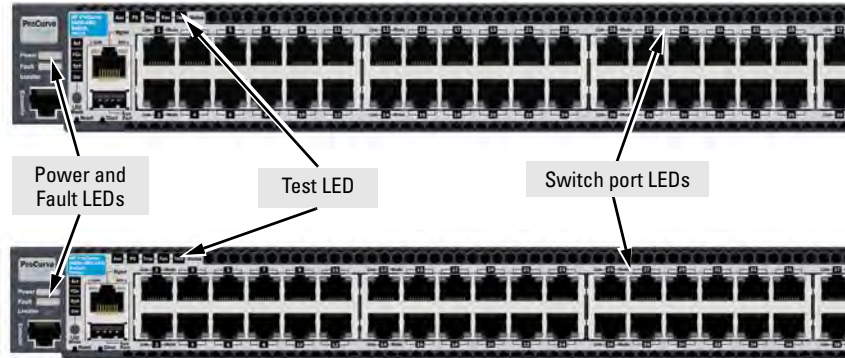

Figure 2-4. Checking the LEDs on the 6600-48G and 6600-48G-4XG

3. When the self-test finishes, disconnect the power cord from the power source.

LED Behavior During Self-Test

During the self-test:

- Status, LED Mode and port LEDs stay on during most of the test.
- Most of the LEDs go off and then may come on again during phases of the self-test.
- The Test LED stays on for the duration of the self-test.

If the self-test completes successfully:

- The **Power** and **Fan Status** LEDs remain on.
- The **Fault** and **Test** LEDs go off.
- The port LEDs on the front of the switch go into their normal operational mode:
 - If the ports are connected to active network devices, the LEDs behave according to the LED Mode selected. In the default view mode (Link), the LEDs should be on.
 - If the ports are not connected to active network devices, the LEDs stay off.

If the self-test does not complete correctly, the LED display will be different than what is described above; for example:

- The **Fault** and **Test LEDs** stay on for more than 60 seconds.
- The **Fault** and **Test LEDs** start blinking.

Refer to Chapter 4, “Troubleshooting” for diagnostic help.

3. (Optional) Reverse the air flow

In a 4-post rack mounting, you must ensure that the air flow direction in a 6600 Switch is from the cold side to the hot side of the aisle. If necessary, reverse the direction of the fans to provide adequate switch cooling. For example, reversing the air flow direction is required in a port-side mounting in which the port side of a 6600 Switch faces the cold aisle and the air flow is from the power (hot aisle) to the port (cold aisle) side.

The default air flow direction is from the power to the port side as shown in Figure 2-1.

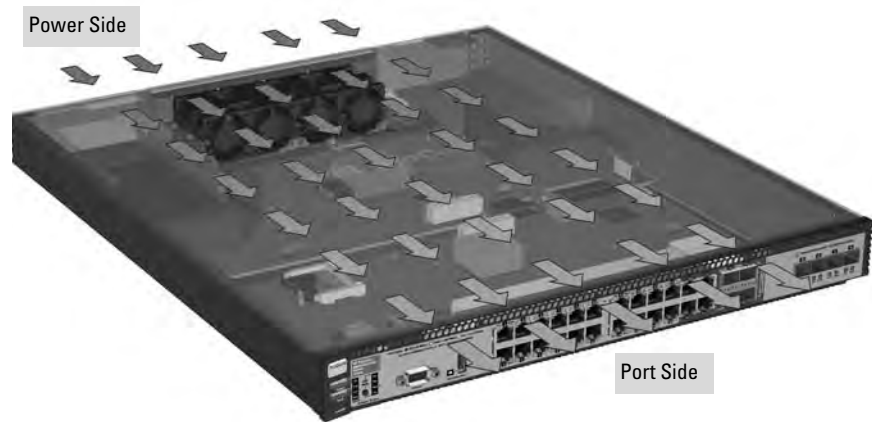

Figure 2-5. Default air-flow direction in 6600 Switches is from power to ports.

Note

Although reversing the direction of air flow on a switch is a hot swap operation, HP ProCurve recommends that you perform the operation after powering down the switch.

If you remove the fan tray while a switch is running, you have only three minutes before the switch powers down the ports. To re-enable the ports, you must reset the switch either by pressing the Reset button or powering off and on the switch.

Important

If you reverse the direction of the fans to provide adequate switch cooling, be sure to record the preferred air-flow direction for a 6600 Switch by using the **system fan-pref-airflow-dir { port-to-power | power-to-port }** CLI command at the global configuration level. A Syslog message is then generated if the fan tray is installed in the wrong direction in the future.

To reverse the direction of air flow:

1. Remove the fan tray assembly
 - a. Unscrew the retaining screws
 - b. Holding the two retaining screws, pull the fan tray assembly straight out.



2. Using a T10 screwdriver, remove the four retaining screws.
3. Lift the fan assembly from the fan tray high enough to turn it over.

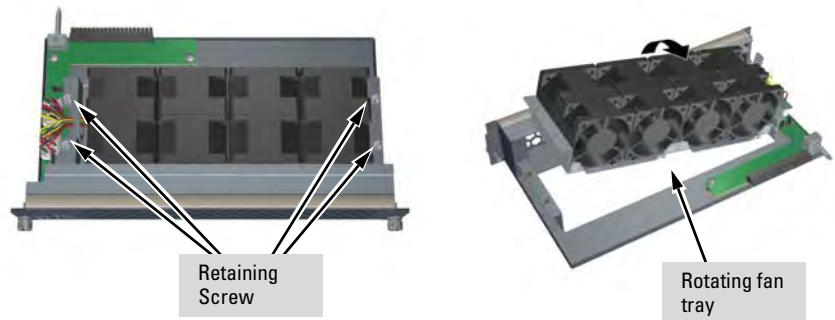

Installing the Switch

Installation Procedures

4. Rotate the fan assembly 180 degrees and replace the fan assembly into the fan tray, sheet metal side up.

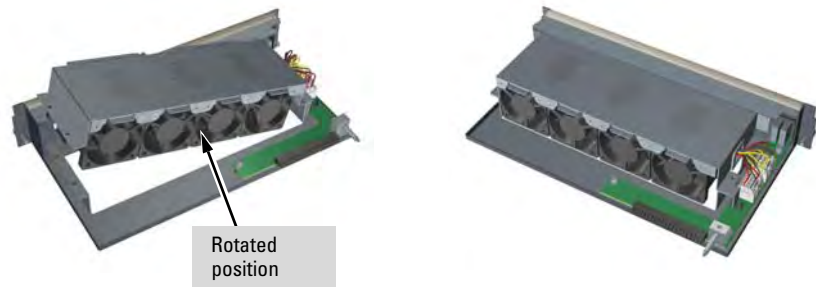

5. Take care to align the sensing pin between the two sensors and replace the 4 retaining screws.

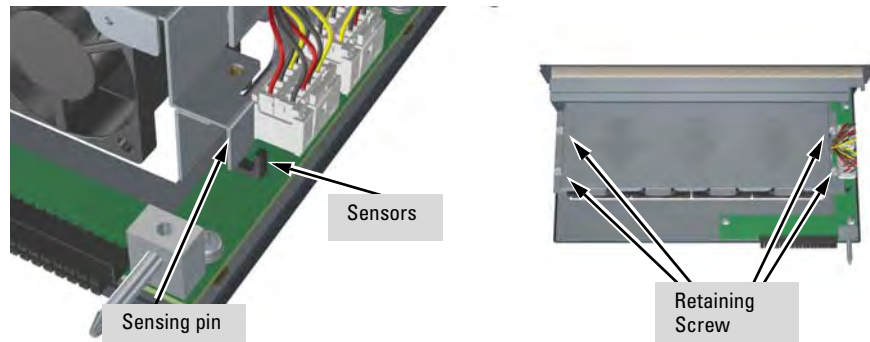

6. Replace the fan tray assembly into the switch.
7. Tighten the retaining screws.

4. Mount the Switch and Route the Power Cords

After a switch passes the self-test, it is ready to be mounted in a stable location.

Rack or Cabinet Mounting

WARNING

For safe operation, please read the mounting precautions on [page 2-3](#) before mounting a switch.

6600 Switches are designed to be mounted in any of the following racking configurations:

- 4-post rack in an equipment cabinet using the *HP Procurve 6600 Switch: 4-Post Rack Mount Kit (J9469A)*.

Secure the rack in accordance with the manufacture's safety guidelines. See "Mounting a 6600 Switch with the 4-Post Rack Mount Kit" on page 2-12 for detailed information.

- 4-post rack in an HP 10000 Series cabinet using the *HP 10000 Series Cabinet: Rack Mount Kit (5070-0145)*.

See "Mounting a 6600 Switch with the 4-Post Rack Mount Kit" on page 2-12 for detailed information.

- 2-post EIA-standard 19-inch telco rack, using a balanced or center mounting orientation. Flush mounting in a 2-post rack is not supported.

See "Mounting the Switch in a 2-Post Telco Rack" on page 2-22 for detailed information.

Rack Mounting Notes

The four 12-24 (5/8 inch) screws shipped in the accessory kit with a 6600 Switch have the correct threading for standard EIA/TIA open 19-inch (2-post) racks. If you are installing the switch in a 4-post rack, such as a server cabinet, use the clips and screws that are provided with the cabinet instead of the 12-24 screws that are shipped with the switch.

The direction of air flow in a 6600 Switch is set by default from the power to the port side. When you mount a 6600 Switch with the port side or power side facing the cold aisle, you must ensure that the air flow direction is from the cold side to the hot side of the aisle. If necessary, reverse the direction of the fans to provide adequate switch cooling as described in "3. (Optional) Reverse the air flow" on page 2-8.

Mounting a 6600 Switch with the 4-Post Rack Mount Kit

6600 Switches are designed to be mounted in a 4-post rack. To mount a 6600 Switch in a 4-post rack in an equipment cabinet, you must use the *HP ProCurve 6600 Switch: 4-Post Rack Mount Kit (J9469A)*.

To mount a 6600 Switch in a 4-post rack, follow these steps. Refer to the *HP ProCurve 6600 Switch: 4-Post Rack Mount Kit Installation Instructions* for additional information.

1. Determine the height at which you want to mount the switch in the rack, and whether the switch ports will face the hot-aisle or the cold-aisle side of an equipment cabinet. Unpack the contents of the *4-Post Rack Mount Kit (J9469A)* required for your 4-post mounting.

Power Cord Note

When you mount a 6600 switch in a 4-post equipment rack, remember that if the switch ports face in the same direction as the network ports on the servers, you may have to wrap the power cord over the top of the switch to reach the opposite side of the rack where the power source is.

2. Install the two rails in the 4-post rack.

Align the mounting holes at each end of a rail with the holes on the front and back rack posts so that they are at the same height.

For a square-hole rack, leave the pre-installed square-hole pin in each rail. Unscrew and re-install the 10-32 screw on each rail to secure it to the rack. (For a square-hole Panduit rack with grounding strips, unscrew the 10-32 screws and install the green grounding screws (5183-2026) shipped with the 4-Post Rack Mount Kit.)

For a round-hole rack, install the alternate round-hole pins that are shipped with the kit to set the rails in the rack. Install the alternate round-hole screws to secure the rails. (The round-hole screws have a different shoulder than the square-hole screws.)



Figure 2-6. Installing Rails in a 4-Post Rack

3. Install the mounting brackets on the switch. (The mounting brackets are shipped with the *HP Procurve 6600 Switch: 4-Post Rack Mount Kit*.)

If you install a 6600 Switch with the power side facing the cold aisle, you must install the switch as shown in Option 1 or 2 to leave space for an air plenum.

If you install a 6600 Switch with the port side facing the cold aisle, you must install the switch as shown in Option 3 without an air plenum.

Depending on whether you install the switch in a power-side or port-side mounting, locate the set of holes where you want to attach the mounting brackets. Use eight M4 8mm screws (four per bracket) to attach both brackets.

Note that in a power-side mounting, you must attach the brackets in different positions according to the length of a 6600 Switch. The brackets will extend beyond the back of the switch.

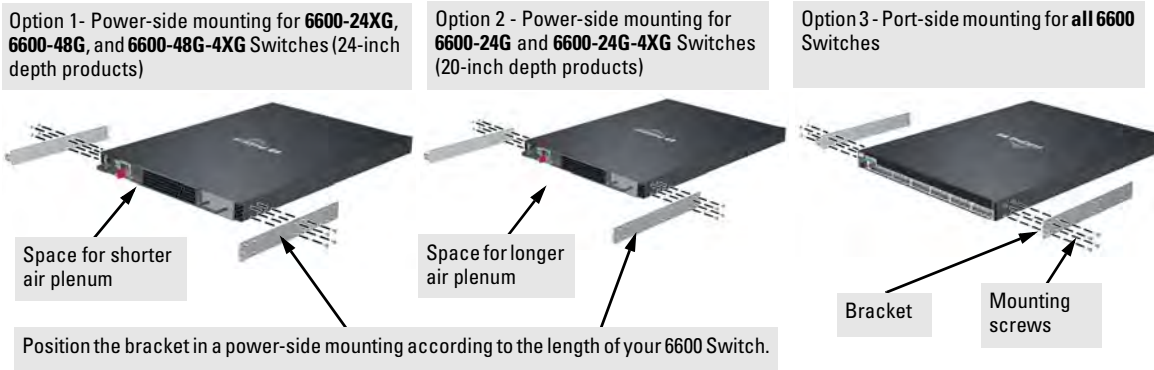

Figure 2-7. Attaching the Mounting Brackets on a 6600 Switch

4. Slide the switch onto the rails until the switch is fully inserted and the mounting hole in each bracket lines up with the mounting holes in the rack.

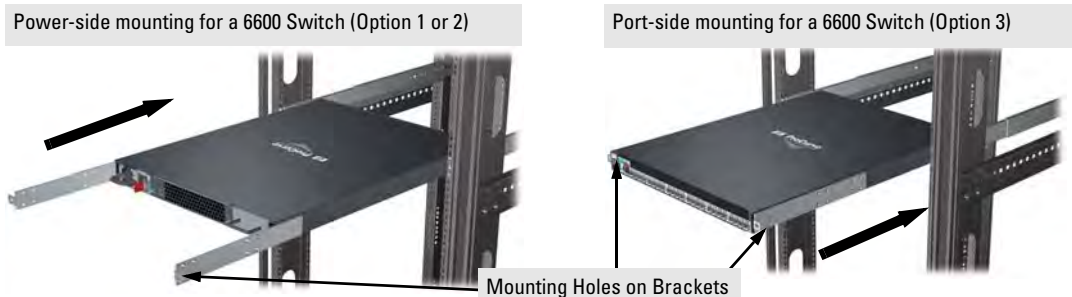

Figure 2-8. Installing a 6600 Switch in a 4-Post Rack

5. Connect the power cords to the switch and route the cords through the rack.
 - a. Connect each power cord to a power supply and secure the cord with a velcro strap. Route each cord through the rack.
 - b. Install the air plenum in a power-side mounting.

Caution

Make sure the air flow is not restricted in the front or back of the switch. Figure 2-1 on [page 2-8](#) shows the default air flow direction from power to ports.

If you are installing a 6600 Switch with the port side facing the cold aisle, no air plenum is necessary. Continue with Step 6.

If you are installing a 6600 Switch with the power side facing the cold aisle, an air plenum is necessary. Use the correct plenum for the size of the switch being installed. The plenum comes in two sizes. Both plenums are installed in the same way.

- J9480A is the shorter air plenum for 6600-24XG, 6600-48G, and 6600-48G-4XG Switches.
- J9481A is the longer air plenum for 6600-24G and 6600-24G-4XG Switches.

After you connect and route the power cords, slide the plenum into the rails until the plenum is fully inserted and the two mounting holes align with the mounting holes on the bracket and rack.



Figure 2-9. Installing an Air Plenum

Figure 2-10 and Figure 2-11 show different ways in which you can route a power cord through the plenum in a power-side mounting.

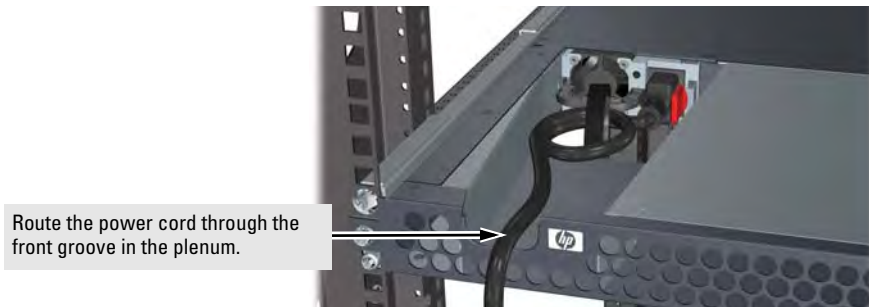

Figure 2-10. Routing a Power Cord Through the Front of the Plenum

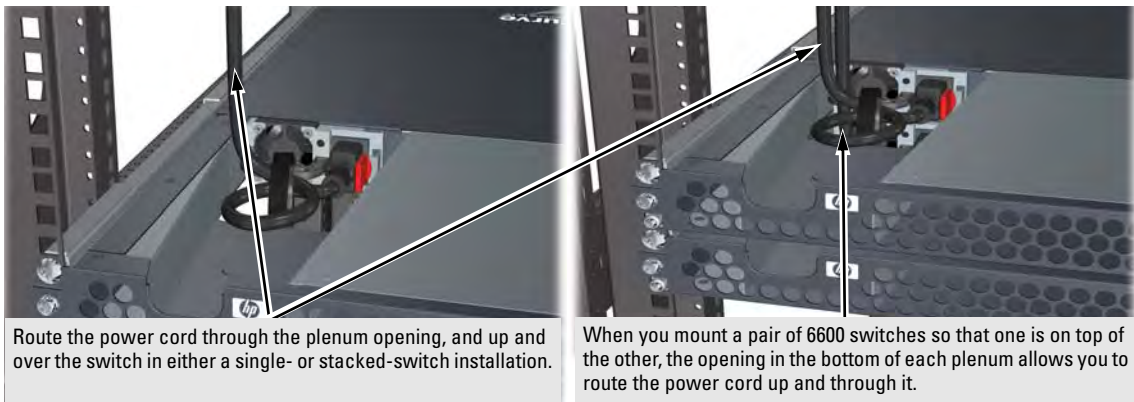

Figure 2-11. Routing a Power Cord Up and Over a 6600 Switch

6. Secure the switch to the rack.

Use two 10-32 screws (one for each bracket) to tighten the plenum and mounting bracket (in a power-side mounting) or only the bracket (in a port-side mounting) to the rack.

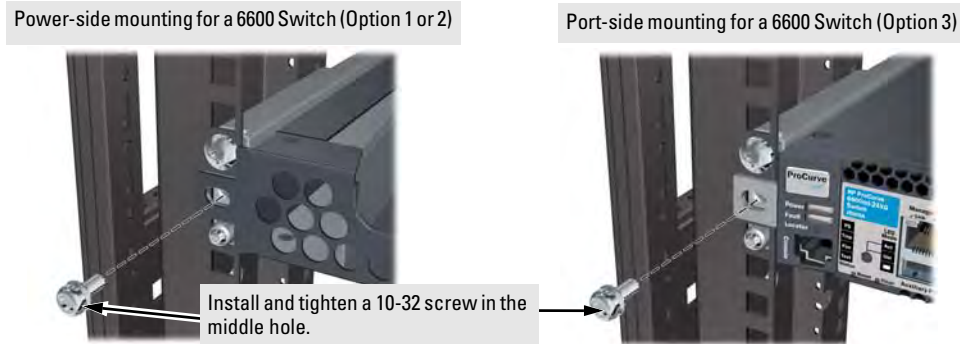

Figure 2-12. Securing a 6600 Switch to the Rack

Mounting a 6600 Switch in an HP 10000 Series Cabinet

6600 Switches can also be mounted in an HP 10000 Series cabinet using the *HP 10000 Series Cabinet: Rack Mount Kit* (5070-0145).

To mount a 6600 Switch with this rack mount kit, follow the procedure below. Refer to the *HP 10000 Series Cabinet: Rack Mount Kit Installation Instructions* for additional information.

1. Determine the height at which you want to mount the switch in the rack, and whether the switch ports will face the hot-aisle or the cold-aisle side of an equipment cabinet. Unpack the contents of the *Rack Mount Kit* (5070-0145) required for your HP 10000 Series 4-post mounting.

HP 10000 Series Notes

When you mount a 6600 switch in an HP 10000 Series cabinet rack, remember that if the switch ports face in the same direction as the network ports on the servers, you may have to wrap the power cord over the top of the switch to reach the opposite side of the rack where the power source is.

Use the clips and screws that are shipped with the cabinet in place of the 12-24 screws that are shipped with the switch. After you determine the height at which you want to mount the switch in the cabinet, install the four clips in the appropriate post holes.

2. Install the two rails (shipped in the rack mount kit) in the HP 10000 Series cabinet.

With a posi-drive screwdriver, install two M6 (16-mm) screws and two M6 cage nuts (shipped in the rack mount kit) to attach each rail to the cabinet rack as shown in the Figure 10. Ensure that the rails are at the same height on each post.

Devices installed in a rack or cabinet should be mounted as low as possible, with the heaviest device on the bottom and progressively lighter devices installed above it.

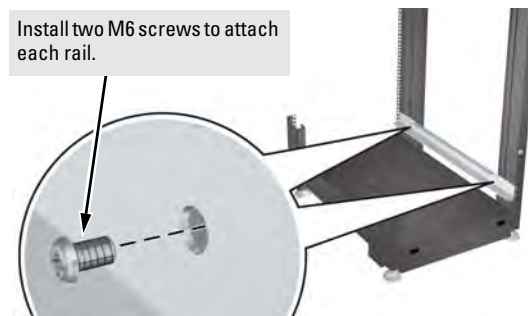

Figure 2-13. Attaching Rails to an HP 10000 Series Cabinet Rack

3. Install the hold-down and mounting brackets on the switch. (The hold-down and mounting brackets are shipped in the *HP 10000 Series Cabinet: Rack Mount Kit*.)

Use a #1 Phillips (cross-head) screwdriver to attach the hold-down brackets (shipped in the rack mount kit) and the mounting brackets (shipped with the switch) with the M4 (8 mm) flat-head screws (shipped with the switch).

Install a hold-down bracket with two M4 screws.

Install a mounting bracket with four M4 screws.

Figures 11, 12, and 13 show where to install the hold-down and mounting brackets on a 6600 Switch chassis when either the port side or the power side face the cold aisle.

Installing the Switch Installation Procedures

Option 1 - Power-side mounting for **6600-24XG**, **6600-48G**, and **6600-48G-4XG** Switches (24-inch depth products)



Install each hold-down bracket in the middle of the switch with two M4 screws so that the bracket holes are near the top of the switch.



In an Option 1 power-side mounting, install each mounting bracket with four M4 screws as shown here. The brackets will extend from the back of the switch to leave space for the shorter air plenum.

**Figure 2-14. Installing Hold-down and Mounting Brackets on a 6600 Switch:
Option 1 - Power-Side Mounting**

Option 2 - Power-side mounting for **6600-24G** and **6600-24G-4XG** Switches (20-inch depth products)



Install each hold-down bracket in the middle of the switch with two M4 screws so that the bracket holes are near the top of the switch.



In an Option 2 power-side mounting, install each mounting bracket with four M4 screws as shown here. The brackets will extend from the back of the switch to leave space for the longer air plenum.

**Figure 2-15. Installing Hold-down and Mounting Brackets on a 6600 Switch:
Option 2 - Power-Side Mounting**

Option 3 - Port-side mounting for all 6600 Switches



Install each hold-down bracket with two M4 screws at the back of the switch. Ensure that the end of the bracket is flush with the end of the switch and does not hang over.

No air plenum is used in a port-side mounting.



Install each mounting bracket with four M4 screws so that the end of the mounting bracket is flush with the front panel of the 6600 Switch.

**Figure 2-16. Installing Hold-down and Mounting Brackets on a 6600 Switch:
Option 3 - Port-Side Mounting**

4. Install M6 cage nuts (shipped in the rack mount kit) in the appropriate post holes for the switch you are installing. Then slide the switch into the rails until the switch is fully inserted and the mounting hole in each bracket lines up with the cage nut in each rack post.
 - If you are installing a 6600 Switch with the port side facing the cold aisle, no air plenum is necessary.
 - i. Install two M6 cage nuts in the appropriate post holes. Then slide the switch into the rack and secure it using two M6 screws (one screw and cage nut per bracket).
 - ii. Connect each power cord to the switch and secure it with a velcro strap. Then route each cord through the rack.

In a port-side-front mounting, slide the 6600 Switch into the rails.



Install and tighten an M6 screw in each mounting bracket to secure the 6600 Switch.



Figure 2-17. Installing a 6600 Switch in a Port-Side HP 10000 Series Mounting

- If you are installing a 6600 Switch with the power side facing the cold aisle:
 - i. Install an M6 cage nut in the appropriate hole on each rack post. Then slide the switch into the rack until the switch is fully inserted and the mounting hole in each bracket lines up with the cage nut in each rack post.
 - ii. Connect each power cord to a power supply and secure the cord with a velcro strap. Then route each cord through the rack. (See “Routing a power cord” on page 2-21 for examples.)
 - iii. Install the air plenum. (See “Installing an Air Plenum” on page 2-21 for more information.)

In a power-side-front mounting (Option 1 or 2), slide the switch and plenum into the rails.



Figure 2-18. Installing a 6600 Switch in a Power-Side HP 10000 Series Mounting with an Air Plenum

- iv. Use two M6 screws (one screw for each bracket) to tighten the plenum and the mounting bracket to the rack.

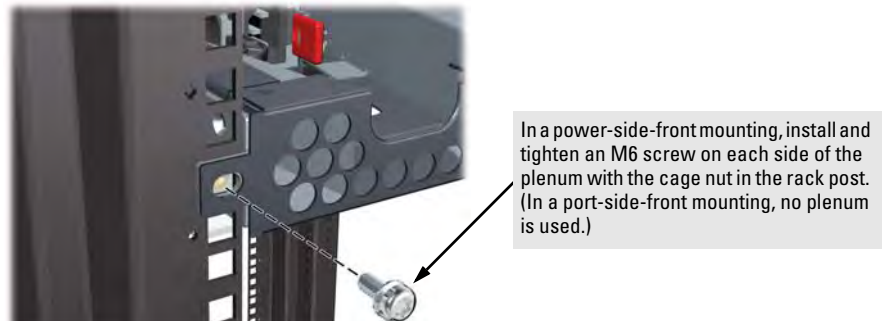

Figure 2-19. Securing a 6600 Switch in an HP 10000 Series Mounting

Routing a power cord. Figure 10 shows different ways in which you can route a power cord through the plenum in a power-side mounting.

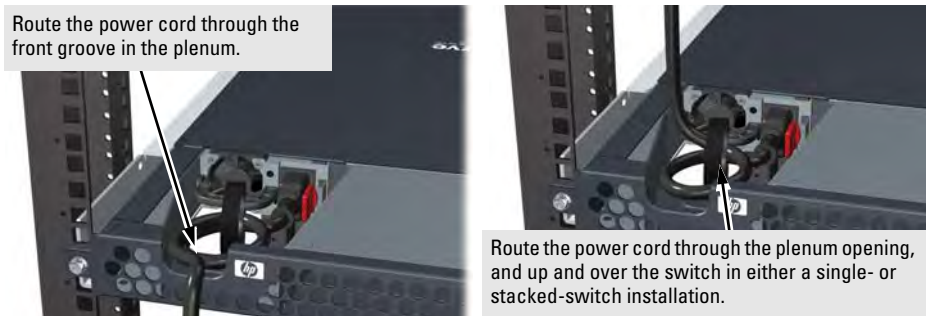

Figure 2-20. Routing a Power Cord Through the Front of the Plenum or Up and Over the Switch

Installing an Air Plenum. Be sure to use the correct plenum for the size of the 6600 Switch being installed. The plenum comes in two sizes. Both plenums are installed in the same way.

- J9480A is the shorter air plenum for 6600-24XG, 6600-48G, and 6600-48G-4XG Switches.
- J9481A is the longer air plenum for 6600-24G and 6600-24G-4XG Switches.

Slide the plenum into the rails until the plenum is fully inserted and the mounting hole on each side lines up with the with the cage nut in the rack post.

Mounting the Switch in a 2-Post Telco Rack

The accessory kit shipped with a 6600 Switch contains the parts used to mount the switch in a 2-post telco rack:

- Two mounting brackets for a 2-post telco rack
- Eight M4 (8 mm) screws to attach the mounting brackets (four screws per bracket)
- Four 12-24 (5/8 inch) screws to attach the mounting brackets to a 2-post telco rack (two screws per post)

The 12-24 screws shipped with the switch have the correct threading for standard EIA/TIA open 19-inch racks.

Although the 2-post mounting brackets have multiple mounting holes and can be rotated for different mounting options, HP ProCurve recommends that you always mount a 6600 Switch in a 2-post telco rack in the balanced position shown in Figure 2-21.



Figure 2-21. Mounting a 6600 Switch in 2-Post Rack

To mount a 6600 Switch in a 2-post telco rack, follow these steps:

1. Using a #1 Phillips (cross-head) screwdriver, install the 2-post mounting brackets at the center of the switch with the M4 (8 mm) screws. Use four screws per bracket.
2. Determine the height at which you want to mount the switch in the rack and with the help of another person, lift the switch into place.
3. Insert and tighten the 12-24 (5/8-inch) screws to secure each 2-post bracket to the rack. Use two screws per post.
4. Connect the power cords to the switch and secure the cords with a velcro strap (as shown Figure 2-22) as follows:
 - a. Connect the power cord to the power supply.

- b. Make a small loop in the power cord, approximately 3 to 4 inches and insert the velcro strap through the loop and through the handle on power supply.
- c. Insert the end of the velcro strap through the slot in the other end of the velcro strap.
- d. Tighten the velcro strap around the loop in the power cord.
- e. Wrap the excess velcro strap around the power cord loop and through the power supply handle a couple of times and secure the velcro strap to itself.

a.



b.



c.



d.



e.



Figure 2-22. Connecting and Securing a Power Cord to a 6600 Switch

5. Connect the Switch to a Power Source

Plug the power cord into the power connector on the back of the switch and into a nearby AC power source.

Re-check the LEDs during the self-test as described in “LED Behavior” on [page 2-7](#).

6. (Optional) Install Transceivers

You can install or remove a transceiver from a transceiver slot without having to power off the switch. A 6600 Switch supports only HP ProCurve transceivers, including:

- 1-Gigabit SFP (mini-GBIC)
- 10-Gigabit SFP+

Notes

- On 6600-24G, 6600-24G-4XG, and 6600-48G Switches, the four SFP slots are shared with 10/100/1000Base-T RJ-45 ports. If an SFP transceiver is installed in a slot, the associated RJ-45 port is disabled and cannot be used.
- An SFP+ (10-GbE) transceiver is not supported in an SFP (1-Gigabit) slot and does not function. The following event log message is generated: “Transceiver type not supported by this port”.

Similarly, an SFP (1-Gigabit) transceiver is not supported in an SFP+ (10-GbE) slot. The same event log message is generated, and the transceiver does not function.

- Ensure the network cable is NOT connected when you install or remove a transceiver unless you are using a Direct Attach Cable (DAC).
-

Note

Direct attach cables (DAC) are low-cost 10-GbE connectivity options consisting of a one, three, or seven meter cable with SFP+ connectors permanently attached to each end.



Figure 2-23. One meter DAC

Caution

Use only supported genuine HP ProCurve transceiver accessories with your switch. Non-ProCurve transceiver accessories are not supported, and their use may result in product malfunction. If you need additional HP ProCurve transceiver accessories, contact your HP ProCurve Networking Sales and Service Office or authorized dealer.

Installing a Transceiver

Hold a transceiver by its sides and gently insert it into any of the transceiver slots on the switch until the transceiver clicks into place.



Figure 2-24. Installing a Transceiver

WARNING

The HP ProCurve optical transceivers are Class 1 laser devices. Avoid direct eye exposure to the beam coming from the transmit port.

- SFP transceivers are supported in the following slots on 6600 Switches:
 - 6600-24G and 6600-24G-4XG: Slots 21S, 22S, 23S, and 24S
 - 6600-48G: Slots 45S, 46S, 47S, and 48S
 - 6600-24XG and 6600-48G-4XG Switches do not support SFP transceivers.
- SFP+ transceivers are supported in the following slots on 6600 Switches:
 - 6600-24XG: All slots (1 to 24)
 - 6600-24G-4XG: Slots 25, 26, 27, and 28
 - 6600-48G-4XG: Slots 49, 50, 51, and 52
 - 6600-24G and 6600-48G Switches do not support SFP+ transceivers.

After you install a transceiver, if the switch recognizes the transceiver, the Mode LED turns on solid for 2 seconds and then goes to normal operation.

Transceiver Usage Notes

After you insert an SFP or SFP+ transceiver, do not remove the transceiver until the Mode LED turns off.

If you insert a faulty or non-ProCurve transceiver, the Fault LED and Link LED of the affected port displays a slow flash for situations that cannot be fixed by the customer.

If you insert a transceiver that is functional but not supported (such as an SFP transceiver in an SFP+ slot or an SFP+ transceiver in an SFP slot), the Link LED of the affected port displays an orange fast flash. Event log messages are generated. For example, this error condition occurs when an inserted transceiver is not supported by the switch software, is the wrong revision, or is the wrong transceiver type.

Removing a Transceiver

Important

Be sure to disconnect the network cable from a transceiver before you remove the transceiver from the switch.

An HP ProCurve transceiver may have any of the following release mechanisms:

- A plastic tab on the bottom of the transceiver
- A plastic collar around the transceiver
- A wire bail

To remove a transceiver that has a plastic tab or plastic collar, push the tab or collar toward the switch until you see the transceiver release from the switch (you will see it move outward), and then pull the transceiver from the slot.

To remove a the transceiver that has a wire bail, lower the bail until it is horizontal, and then using the bail, pull the transceiver from the slot.

7. Connect the Network Cables

Connect the network cables, described under “Cabling Infrastructure” (page 2-5), from the network devices or your patch panels to the fixed RJ-45 ports on the switch or to any transceivers you have installed in the switch.

Using the RJ-45 Connectors

To connect: Push the RJ-45 plug into the RJ-45 jack until the tab on the plug clicks into place. When power is on for the switch and the connected device, the Link LED for the port should light to confirm a powered-on device (for example, an end node) is at the other end of the cable.

If the Link LED does *not* go on when the network cable is connected to the port, go to “Using LEDs to Diagnose an Error Condition” on page 5-4 to troubleshoot the problem.

To disconnect: Press the small tab on the plug and pull the plug out of the jack.

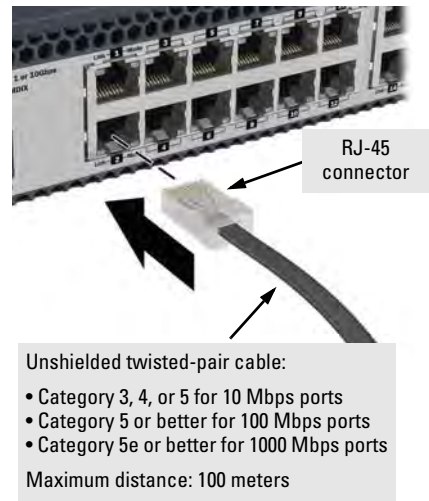

Figure 2-25. Connecting RJ-45s

Connecting Cables to Transceivers

Note

Each of the four SFP (mini-GBIC) slots is shared with an associated 10/100/1000Base-T RJ-45 port. If an SFP transceiver is installed in a slot, the associated RJ-45 port is disabled.

If you have any transceivers installed in the switch, the type of network connections you will need to use depends on the type of transceivers you have installed. See Appendix B, “Cabling and Technology Information”, for information on transceiver cabling.

For transceiver ports, and in general for all the switch ports, when a network cable from an active network device is connected to the port, the port LED for that port should go on. If the port LED does *not* go on when the network cable is connected to the port, see [“Using LEDs to Diagnose an Error Condition” on page 5-4](#) in chapter 5, “Troubleshooting”.



Figure 2-26. Connecting an LC Fiber Optic Connector

8. (Optional) Connect a Management Console

6600 Switches have a full-featured, easy-to-use console interface for performing switch management tasks including:

- Monitor switch and port status, and network activity statistics.
- Modify the switch’s configuration to optimize switch performance, enhance network traffic control, and improve network security.
- Read the event log and access diagnostic tools to help in troubleshooting.
- Download new software to the switch.
- Add passwords to control access to the switch from the console, web browser interface, and network management stations.

After you install and power up a 6600 Switch, you must use the out-of-band console connection to minimally configure the switch with an IP address and subnet mask before you can use a networked (in-band or out-of-band) connection to manage the switch. The minimal switch configuration is described in “Minimal Configuration Through the Out-of-Band Console Connection” on page 3-2.

To connect a console to the switch, use the console cable shipped with the switch and connect a PC or VT-100 terminal to the Console serial port. The PC or terminal then functions as a management console connected directly to the switch.

You can use the Console port only for out-of-band management; it cannot be used for a Telnet connection.

Configuring the Management Console

To set up a console to manage the switch through the Console port connection:

1. Configure the PC terminal emulator as a DEC VT-100 (ANSI) terminal or use a VT-100 terminal.
2. Configure the terminal with the following settings:
 - A baud rate from 1200 to 115200 (the switch senses the speed)
 - 8 data bits, 1 stop bit, no parity, and flow control set to Xon/Xoff
 - For the Windows Terminal program, disable (uncheck) the “Use Function, Arrow, and Ctrl Keys for Windows” option.
 - For the Hilgraeve HyperTerminal program, select the “Terminal keys” option for the “Function, Arrow, and Ctrl Keys act as” parameter.

If you use a management console with different configuration settings, be sure to reconfigure the settings on both the terminal and the switch in the following order so that both configurations are compatible:

1. Reconfigure the switch and save the new settings.
2. Reconfigure the terminal and save the new settings.
3. Reboot the switch and re-establish the console session.

Setting Up an Out-of-Band Console Connection

To access a 6600 Switch through an out-of-band (Console port) connection, follow these steps:

1. Configure the management console as described in “Configuring the Management Console” on page 2-29.
2. For a direct console connection, connect the PC or terminal to the Console serial port using the console cable shipped with the switch:
 - A DB9-to-DB9 console cable and a DB9-to-RJ45 adapter are shipped with the 6600-24G, 6600-24G-4XG Switches.
 - A DB9-to-RJ45 console cable is shipped with the 6600-24XG, 6600-48G, and 6600-48G-4XG Switches. For the DB9-to-RJ45 console cable pinouts, see “RJ45-to-DB9 Console Cable Pinouts” on page 2-31.

If your PC or terminal has a 25-pin serial connector, first attach a 9-pin to 25-pin straight-through adapter at one end of the console cable.

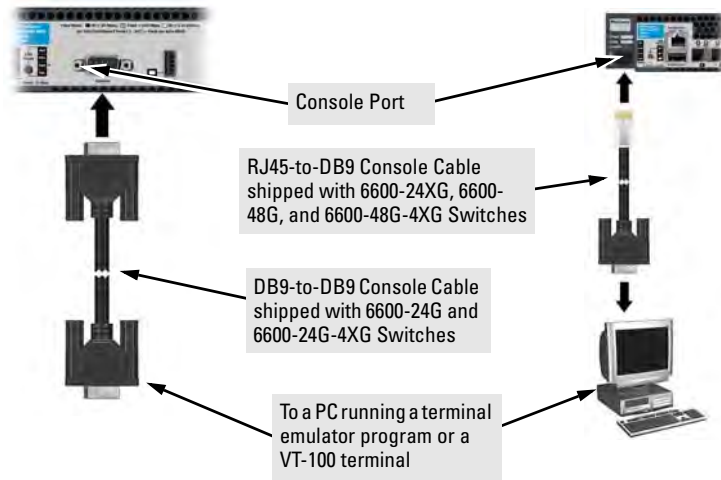

Figure 2-27. Connecting the Cable for a Direct Console Connection

3. Power on the management console (terminal or PC). If you are using a PC, start the PC terminal program.
4. For a direct console connection through the Console port:
 - a. Press **[Enter]** two or three times to display the copyright page and the message “Press any key to continue”.
 - b. Press any key to display the switch console command (CLI) prompt; for example: `ProCurve Switch 6600-24G#`
 - c. Continue the console session to configure the switch by following the procedure in [“Minimal Configuration Through the Out-of-Band Console Connection”](#) on page 3-2.

Important

You must use the out-of-band console connection to minimally configure the switch with an IP address and subnet mask before you can use an in-band or out-of-band networked connection to manage the switch. Continue with “Recommended Minimal Configuration” on page 3-1 for more information.

RJ45-to-DB9 Console Cable Pinouts. A console cable may have an RJ-45 male connector on one end and a DB-9 female connector on the other end. Table 2-16 describes the mapping of the RJ-45 to DB-9 pins.

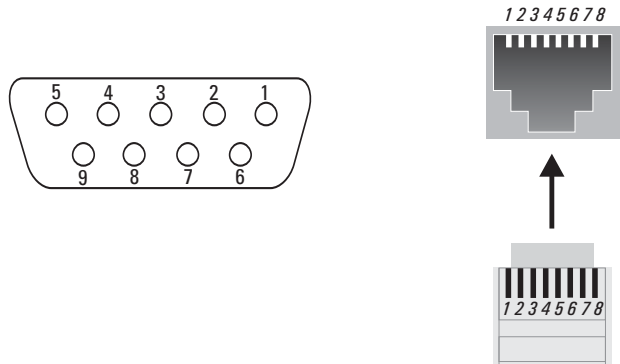

Figure 2-28. RJ-45 to DB-9 Pinouts

Table 2-1. Mapping of RJ-45 to DB-9

RJ-45 (Signal reference from Chassis)		DB-9 (Signal reference from PC)	
Reserved	1	8	CTS
Reserved	2	6	DSR
TXD	3	2	RXD
Reserved	4	1	DCD
GND	5	5	GND
RXD	6	3	TXD
Reserved	7	4	DTR
Reserved	8	7	RTS
		9	RI

Sample Network Topology

An industry-standard building block approach requires that applications can be adapted to a common server environment. Virtualization of these resources allows for improved scaling, flexibility, and efficient use of resources, while delivering seamless interoperability.

In such a model, the server/access layer of a network infrastructure can be completely standardized and continuously deployed without regard to application requirements.

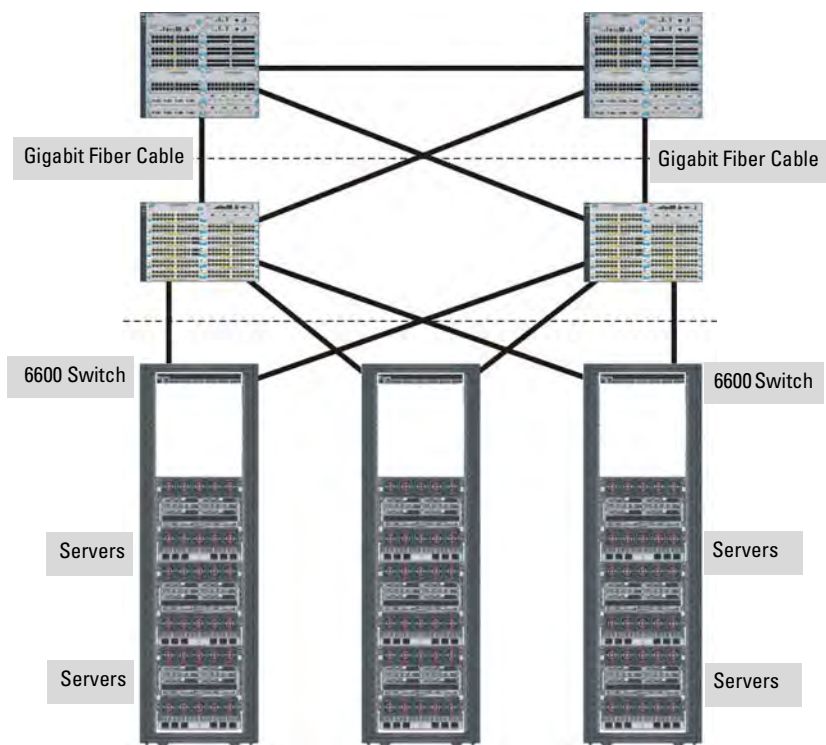

Figure 2-29. Sample Topology

Getting Started With Switch Configuration

This chapter is intended as a guide for using the console Switch Setup screen to quickly assign an IP (Internet Protocol) address and subnet mask to the switch, set a Manager password and, optionally, configure other basic features.

For more information on using the switch console and the other switch management interfaces: the web browser interface and the SNMP management tool, ProCurve Manager, please see the *Management and Configuration Guide*, which is on the ProCurve Web site at www.procurve.com/manuals.

Recommended Minimal Configuration

In the factory default configuration, the switch has no IP (Internet Protocol) address and subnet mask, and no passwords. In this state, it can be managed only through a direct console connection.

To manage the switch through a networked (in-band data port or out-of-band management port) connection, you must first configure the switch with an IP address and subnet mask compatible with your network.

Also, you should configure a Manager password to control access privileges from the console and web browser interface. Other parameters in the Switch Setup screen can be left at their default settings or you can configure them with new values.

You can configure many other switch features through the switch's console interface to:

- Optimize switch performance.
- Enhance control of network traffic.
- Improve network security.

After you configure an IP address on the switch, you can manage these features more conveniently in any of the following ways:

- A remote Telnet session
- A web browser interface
- An SNMP network management station running a network management program, such as ProCurve Manager.

For a list of switch features available with and without an IP address, refer to “How IP Addressing Affects Switch Operation” in the *Management and Configuration Guide* at www.procurve.com/manuals.

For more information on IP addressing, refer to “IP Configuration” in the *Management and Configuration Guide*.

Note

By default, the switch is configured to acquire an IP address configuration from a DHCP or Bootp server. To use DHCP/Bootp instead of the manual configuration method described in “Minimal Configuration Through the Out-of-Band Console Connection”, see “DHCP/Bootp Operation” in the *Management and Configuration Guide* at www.procurve.com/manuals.

Minimal Configuration Through the Out-of-Band Console Connection

The quickest and easiest way to minimally configure the switch for networked management and password protection is to use the direct (out-of-band) connection through the Console port to start a console session and access the Switch Setup screen.

1. Configure a management console as described in “Configuring the Management Console” on page 2-29.
2. Set up an out-band console connection through the Console port by following the procedure described in “Setting Up an Out-of-Band Console Connection” on page 2-29. The 6600 command-line prompt should be displayed on the console screen with the switch model number; for example:
ProCurve 6600-24G Switch#
3. At the prompt, enter the **setup** command to display the Switch Setup screen. The following illustration shows the Setup screen with the default settings.

```

ProCurve Switch 6600-24G                               1-Jan-2008  2:59:24
-----
CONSOLE - MANAGER MODE
Switch Setup

System Name : ProCurve Switch 6600-24G
System Contact :
Manager Password :                               Confirm Password :
Logon Default : CLI                               Time Zone [0] : 0
Community Name : public                           Spanning Tree Enabled [No] : No

Default Gateway :
Time Sync Method [None] : TIMEP
TimeP Mode [Disabled] : Disabled

IP Config [DHCP/Bootp] : DHCP/Bootp
IP Address :
Subnet Mask :

Actions->  Cancel      Edit      Save      Help

Enter System Name - up to 25 characters.
Use arrow keys to change field selection, <Space> to toggle field choices,
and <Enter> to go to Actions.
    
```

4. Use the **[Tab]** key to select the **Manager Password** field and enter a manager password of up to 16 characters.
5. **[Tab]** to the **IP Config (DHCP/Bootp)** field and use the Space bar to select the **Manual** option.
6. **[Tab]** to the **IP Address** field and enter the IP address that is compatible with your network.
7. **[Tab]** to the **Subnet Mask** field and enter the subnet mask used for your network.
8. Press **[Enter]**, then **[S]** (for **S**ave).

The following fields are displayed in the Setup screen. For more information on these fields, refer to the *Management and Configuration Guide* at www.procurve.com/manuals:

Switch Setup Parameter	Default	
System Name	blank	Optional; up to 25 characters, including spaces
System Contact	blank	Optional; up to 48 characters, including spaces
Manager Password	blank	Recommended; up to 16 characters (no blank spaces)
Logon Default	CLI	The default setting selects the command line interface for console access. The alternative is the menu interface.
Time Zone	0 (none)	Optional; 1440 to -1440. The number of minutes your location is to the West (-) or East (+) of GMT.

Switch Setup Parameter	Default	
Community Name	public	Default setting recommended.
Spanning Tree Enabled	No	Default setting recommended unless STP is already running on your network or the switch will be used in complex network topologies.
Default Gateway	blank	Optional; Enter the IP address of the next-hop gateway node if network traffic needs to be able to reach off-subnet destinations.
Time Sync Method	None	Optional; The protocol the switch uses to acquire a time signal. The options are SNTP and TimeP.
TimeP Mode	Disabled	Optional; The method the switch uses to acquire the TimeP server address.
IP Config (DHCP/Bootp)	DHCP/Bootp	Set to Manual unless a DHCP/Bootp server is used on your network to configure IP addressing.
IP Address	xxx.xxx.xxx.xxx	Recommended; If you set IP Config to Manual, then enter an IP address compatible with your network.
Note: The IP address and subnet mask assigned for the switch must be compatible with the IP addressing used in your network. For more information on IP addressing, see the <i>Management and Configuration Guide</i> at www.procurve.com/manuals .		
Subnet Mask	xxx.xxx.xxx.xxx	Recommended; If you entered an IP address, then enter a subnet mask compatible with your network.

Where to Go From Here: Networked Connections

After a 6600 Switch is configured with a Manager password, IP address, and subnet mask, you can manage the switch from a networked connection, such as:

- PC equipped with Telnet (see “Starting a Telnet Session” on page 3-6)
- Web browser interface (see “Starting a Web Browser Session” on page 3-6)
- SNMP-based network management station using a tool such as ProCurve Manager.

For more information on these management interfaces and all the features that you can configure on the switch, refer to the *Management and Configuration Guide* at www.procurve.com/manuals.

The following types of networked connections are supported on a 6600 Switch:

- Out-of-band networked connection through the dedicated Management port on 6600-24XG, 6600-48G, and 6600-48G-4XG Switches

To use: Connect an RJ-45 network cable to the Mgmt port to manage a 6600 Switch via Telnet from a remote PC or UNIX workstation.

You must first configure the switch with an IP address and subnet mask by using the out-of-band console connection (see “Minimal Configuration Through the Out-of-Band Console Connection” on page 3-2) or through DHCP/Bootp.

A networked out-of-band connection allows you to manage data network switches from a physically and logically separate management network.

For more information on, refer to the “Network Out-of-Band Management (OOBM)” appendix in the *Management and Configuration Guide* at www.procurve.com/manuals.

- In-band networked connection through a data port on the switch

To use: Connect a PC or UNIX workstation with a VT-100 terminal emulator directly to a switch data port. Then access the switch via Telnet from the workstation

You must first configure the switch with an IP address and subnet mask by using the out-of-band console connection (see “Minimal Configuration Through the Out-of-Band Console Connection” on page 3-2) or through DHCP/Bootp.

For more information on in-band and out-of-band networked connections for switch management, refer to “Using the IP Address for Remote Switch Management” on page 3-6 and the *Management and Configuration Guide* at www.procurve.com/manuals.

Management Sessions

A 6600 Switch can simultaneously support one out-of-band serial console session through the Console port and up to five in-band Telnet/TCP (networked) sessions through data ports on the switch.

Using the IP Address for Remote Switch Management

The switch's IP address can be used to manage the switch from any PC on the same or on a different subnet as the switch. In a networked (in-band or out-of-band) connection, you can use a Telnet session or standard web browser to manage the switch.

Starting a Telnet Session

To access the switch through a Telnet session, follow these steps:

1. Make sure the switch is configured with an IP address and that the switch is reachable from the PC that is running the Telnet session (for example, by using a Ping command to the switch's IP address).
2. Start the Telnet program on a PC that is on the same subnet as the switch and connect to the switch's IP address.
3. You will see the copyright page and the message "Press any key to continue". Press a key, and you will then see the switch console command (CLI) prompt, for example:

ProCurve 6600-24G-4XG Switch#

Enter **help** or **?** to see a list of commands that can be executed at the prompt. Entering any command followed by **help** provides more detailed context help information about the command. Entering any command followed by **?** displays a list of options that are available at that point in the command entry.

Starting a Web Browser Session

A 6600 Switch can be managed through a graphical interface that you access from a PC or workstation on the network by running a web browser and typing in the switch's IP address as the URL. No additional software installation is required to make this interface available; it is included in the switch's onboard software.

The operating systems, web browsers, and Java support required to manage the switch through the browser interface are listed in the following table:

Operating System	Internet Explorer	Java Version
Windows 2000 SP4	5.5 SP2, 6.0 SP1	1.3.1_12 and 1.4.2_05
Windows XP SP1a	6.0 SP1	1.3.1_12 and 1.4.2_05
Windows Server 2003	6.0 SP1	1.3.1_12 and 1.4.2_05

The following illustration shows a typical web browser interface screen.

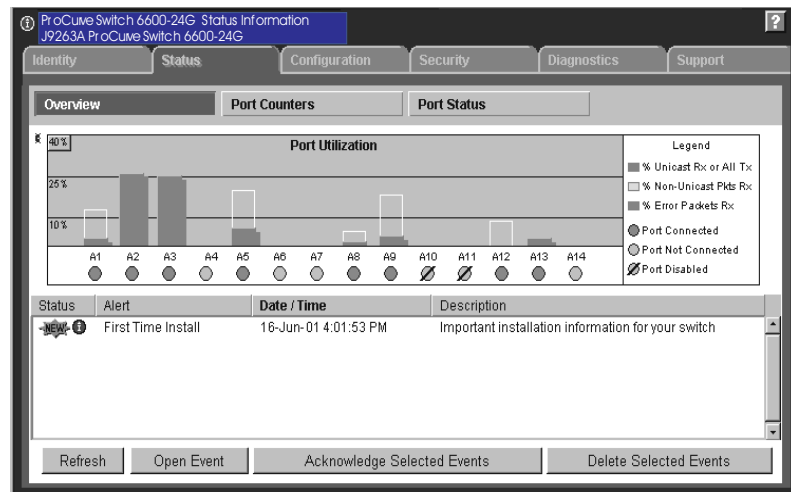

For more information on using the web browser interface, refer to the *Management and Configuration Guide* at www.procurve.com/manuals.

An extensive help system is also available for the web browser interface. To access the help system though, the subnet on which the switch is installed must have access to the internet, or ProCurve Manager needs to be installed on a network management station that is on the subnet.

Getting Started With Switch Configuration
Using the IP Address for Remote Switch Management

Replacing Components

This chapter shows you how to remove and install the following components:

- Fan tray (see [page 4-1](#))
- Power Supplies (see [page 4-3](#))

Caution

The HP ProCurve 6600 Switch and its components are sensitive to static discharge. Use an antistatic wrist strap and observe all static precautions when replacing components.

Replacing the Fan Tray

When a fan fails, the Fan Status LED on the switch chassis blinks simultaneously with the Fault LED. The entire fan tray assembly must then be replaced. You cannot replace individual fans.

Note

Although the fan tray assembly is hot swappable, HP ProCurve recommends that you perform the operation after powering down the switch. If you remove the fan tray while a switch is running, you have only three minutes to remove and replace the fan tray before the switch powers down the ports.

To re-enable the ports, you must reset the switch either by pressing the Reset button or powering off and on the switch.

WARNING

If you hot-swap out the fan tray assembly, to avoid contact with spinning fans, pull the assembly out one-inch and allow the fans to stop rotating (approximately 5 seconds) before pulling it all the way out.

To replace a fan tray assembly:

1. Unscrew the retaining screws.

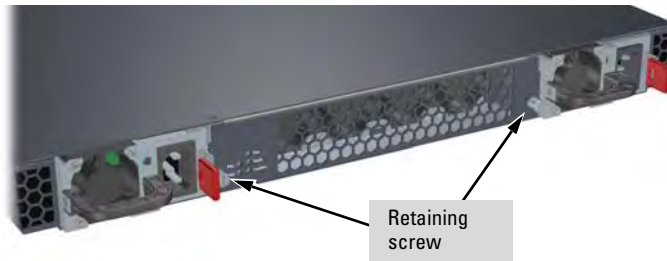

Figure 4-1. Retaining Screws on the Fan Tray Assembly

2. Holding the two retaining screws, pull the fan tray assembly straight out.



Figure 4-2. Removing the Fan Tray Assembly

3. Remove the new fan tray assembly from its packaging.

Note

Before you install a new fan tray, ensure that the air flow direction (power-to-port or port-to-power) is the same as the fan tray that you are replacing.

Replacing a Power Supply

If a 6600 switch is configured with redundant power supplies, the switch does not suffer loss of traffic or performance if a power supply fails. You should replace the failed component as soon as possible. The PS (Power Supply) LED blinks simultaneously with the Fault LED to indicate that a power supply has failed.

To remove an AC power supply:

1. Ensure the failed power supply is not plugged into an AC power source.
2. Grasping the handle of the failed power supply release the locking mechanism by squeezing the latch handle and remove the failed power supply.

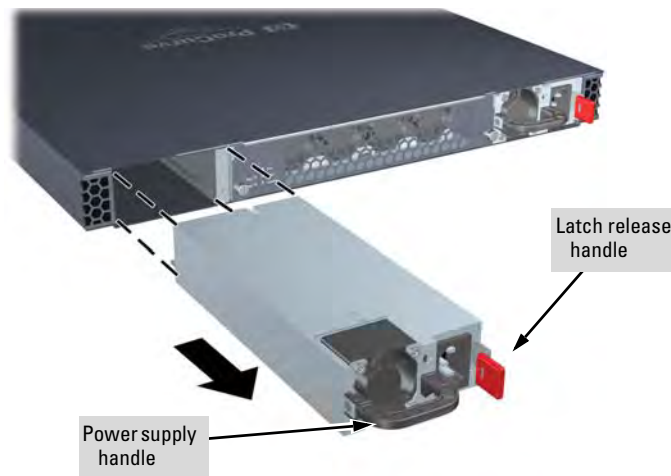

3. Insert the new power supply. Slide it in all the way in until the locking mechanism locks.

Troubleshooting

This chapter describes how to troubleshoot your switch. This document describes troubleshooting mostly from a hardware perspective. You can perform more in-depth troubleshooting on the switch using the software tools available with the switch, including the full-featured console interface, the built-in web browser interface, and ProCurve Manager, the SNMP-based network management tool. For more information, see the chapter “Troubleshooting” in the *Management and Configuration Guide*, which is on the ProCurve Web site at www.procurve.com/manuals.

This chapter describes the following:

- Basic Troubleshooting Tips ([page 5-1](#))
- Diagnosing with the LEDs ([page 5-4](#))
- Proactive Networking Tools ([page 5-8](#))
- Hardware Diagnostic Tests ([page 5-9](#))
- Restoring the Factory Default Configuration ([page 5-11](#))
- Downloading New Switch Software ([page 5-12](#))
- HP Customer Support Services ([page 5-12](#))

Basic Troubleshooting Tips

Most problems are caused by the following situations. Check for these items first when starting your troubleshooting:

- **Connecting to devices that have a fixed full-duplex configuration.** The RJ-45 ports are configured as “Auto”. That is, when connecting to attached devices, the switch will operate in one of two ways to determine the link speed and the communication mode (half duplex or full duplex):
 - If the connected device is also configured to Auto, the switch will automatically negotiate both link speed and communication mode.
 - If the connected device has a fixed configuration, for example 100 Mbps, at half or full duplex, the switch will automatically sense the link speed, but will default to a communication mode of *half duplex*.

Caution

Because the switch behaves in this way (*in compliance with the IEEE 802.3 standard*), if a device connected to the switch has a fixed configuration at *full duplex*, the device will not connect correctly to the switch. The result will be high error rates and very inefficient communications between the switch and the device.

Make sure all devices connected to the switch are configured to auto negotiate, or are configured to connect at half duplex (all hubs are configured this way, for example).

- **Faulty or loose cables.** Look for loose or obviously faulty connections. If they appear to be OK, make sure the connections are snug. If that does not correct the problem, try a different cable.
- **Non-standard cables.** Non-standard and miswired cables may cause network collisions and other network problems, and can seriously impair network performance. Use a new correctly-wired cable or compare your cable to the cable in appendix B, “Cables and Connectors” for pinouts and correct cable wiring. A category 5 cable tester is a recommended tool for every 100Base-TX and 1000Base-T network installation.
- **Improper Network Topologies.** It is important to make sure you have a valid network topology. Common topology faults include excessive cable length and excessive repeater delays between end nodes. If you have network problems after recent changes to the network, change back to the previous topology. If you no longer experience the problems, the new topology is probably at fault. Sample topologies are shown at the end of chapter 2 in this book, and some topology configuration guidelines can be found online on the ProCurve Web site at www.procurve.com/manuals.

In addition, you should make sure that your network topology contains ***no data path loops***. Between any two end nodes, there should be only one active cabling path at any time. Data path loops will cause broadcast storms that will severely impact your network performance.

For your switch, if you wish to build redundant paths between important nodes in your network to provide some fault tolerance, you should enable **Spanning Tree Protocol** support on the switch. This ensures only one of the redundant paths is active at any time, thus avoiding data path loops. Spanning Tree can be enabled through the switch console, the web browser interface, or ProCurve Manager.

The 6600 Switch devices also support **Trunking**, which allows multiple network cables to be used for a single network connection without causing a data path loop. For more information on Spanning Tree and Trunking, see the *Management and Configuration Guide*, which is on the ProCurve Web site at www.procurve.com/manuals.

- **Check the port configuration.** A port on your switch may not be operating as you expect because it has been put into a “blocking” state by Spanning Tree, GVRP (automatic VLANs), or LACP (automatic trunking). (Note that the normal operation of the Spanning Tree, GVRP, and LACP features may put the port in a blocking state.) Or, the port just may have been configured as disabled through software.

Use the switch console to determine the port’s configuration and verify that there is not an improper or undesired configuration of any of the switch features that may be affecting the port. For more information, see the *Management and Configuration Guide*, which is on the ProCurve Web site at www.procurve.com/manuals.

- **Recover from a lost manager password.** If you cannot start a console session at the manager level because of a lost Manager password, you can clear all passwords and user names by pressing and holding the Clear button on the switch for a full second.
- **Receive a log message for incorrect air flow.** The direction of air flow in a 6600 Switch is set by default from the power to the port side. When you mount a 6600 Switch with the port side or power side facing the cold aisle, you must ensure that the air flow direction is from the cold side to the hot side of the aisle. If necessary, reverse the direction of the fans to provide adequate switch cooling as described in “Reverse the air flow” on [page 2-8](#).

If you reverse the direction of the fans, be sure to record the preferred air-flow direction for a 6600 Switch by using the **system fan-pref-airflow-dir** { **port-to-power** | **power-to-port** } CLI command at the global configuration level. A Syslog message is then generated if the fan tray is installed in the wrong direction in the future.

For more information on possible network problems and their solutions, refer to the technical note “Troubleshooting LAN Performance and Intermittent Connectivity Problems”, which can be found on the ProCurve Web site, www.procurve.com/library, under “T” in the A-Z Index section.

Using LEDs to Diagnose an Error Condition

Table 5-1 shows LED patterns on the switch and the switch modules that indicate problem conditions.

1. Check in the table for the LED pattern you see on your switch.
2. Refer to the corresponding diagnostic tip on the next few pages.

Table 5-1. LED Error Indicators

LED Pattern Indicating Problems							Diag Tips
Power	Fault	PS	Tmp	Test	Fan Status	Port LED (in Link view mode)	
Off with power cord plugged in	*	PS LED off or blinking orange	*	*	*	*	1
On	Prolonged On	*	*	Prolonged On	*	*	2
On	Blinking [†]	*	*	Blinking [†]	*	*	3
On	Blinking [†]	*	*	Off	Blinking [†]	*	4
On	Blinking [†]	*	*	Blinking [†]	*	Blinking [†]	5
On	Off	*	*	Off	*	Off with cable connected	6
On	Off	*	*	Off	*	On, but the port is not communicating	7
On	Blinking	Blinking	*	Off	*	*	8
On	Blinking	*	Blinking	Off	*	*	9

* This LED is not important for the diagnosis.
[†] The blinking behavior is an on/off cycle once every 1.6 seconds, approximately.

Diagnostic Tips:

Tip	Problem	Solution
1	The switch is not plugged into an active AC power source, or the switch's power supply may have failed.	<ol style="list-style-type: none"> 1. Verify the power cord is plugged into an active power source and to the switch. Make sure these connections are snug. 2. Try power cycling the switch by unplugging and plugging the power cord back in. 3. If the Power LED is still not on, verify that the AC power source works by plugging another device into the outlet. Or try plugging the switch into a different outlet or try a different power cord. <p>If the power source and power cord are OK and this condition persists, the switch power supply may have failed. Call your ProCurve authorized LAN dealer, or use the electronic support services from ProCurve to get assistance. See the Customer Support/Warranty booklet for more information.</p>
2	A switch hardware failure has occurred. All the LEDs will stay on indefinitely.	Try power cycling the switch. If the fault indication reoccurs, the switch may have failed. Call your ProCurve authorized LAN dealer, or use the electronic support services from HP to get assistance. See the Customer Support/Warranty booklet for more information.
3	The switch has experienced a software failure during self-test.	<ol style="list-style-type: none"> 1. Try resetting the switch by pressing the Reset button on the front of the switch, or by power cycling the switch. 2. If the fault indication reoccurs, attach a console to the switch (as indicated in chapter 2) and configure it to operate at 9600 baud. Then, reset the switch. Messages should appear on the console screen and in the console log identifying the error condition. You can view the console log at that point by selecting it from the console Main Menu. <p>If necessary to resolve the problem, contact your ProCurve authorized LAN dealer, or use the electronic support services from ProCurve to get assistance. See the Customer Support/Warranty booklet for more information.</p>
4	One of the switch cooling fans may have failed.	Try disconnecting power from the switch and wait a few moments. Then reconnect the power to the switch and check the LEDs again. If the error indication reoccurs, one of the fans has failed. The other switch fans may continue to operate under this condition if the ambient temperature does not exceed normal room temperature, but for best operation, the fans should be replaced. Contact your ProCurve authorized LAN dealer, or use the electronic support services from ProCurve to get assistance. See the Customer Support/Warranty booklet for more information.
5	The network port for which the LED is Blinking has experienced a self-test or initialization failure.	<p>Try power cycling the switch. If the fault indication reoccurs, the switch port may have failed. Call your ProCurve authorized LAN dealer, or use the electronic support services from ProCurve to get assistance. See the Customer Support/Warranty booklet for more information.</p> <p>If the port is a pluggable, verify it is one of the pluggables supported by the switch. Unsupported pluggables will be identified with this fault condition. Supported transceivers are described in Chapter 2, "Installing the Switch" on page 2-1. Transceivers are also tested when they are "hot-swapped" — installed or changed while the switch is powered on. Also check the log file for error messages.</p> <p>To verify the port has failed, try removing and reinstalling the transceiver without having to power off the switch. If the port fault indication reoccurs, you will have to replace the transceiver.</p>

Tip	Problem	Solution
<i>continued on the next page</i>		
6	The network connection is not working properly.	<p>Try the following procedures:</p> <ul style="list-style-type: none">• For the indicated port, verify both ends of the cabling, at the switch and the connected device, are connected properly.• Verify the connected device and switch are both powered <i>on</i> and operating correctly.• Verify you have used the correct cable type for the connection:<ul style="list-style-type: none">– For twisted-pair connections to the fixed 10/100 or 10/100/1000 ports, if the port is configured to “Auto” (auto negotiate), either straight-through or crossover cables can be used because of the switch’s “HP Auto-MDIX” feature and the Auto MDI/MDI-X feature of the 10/100/1000-T port. <hr/> <p>Note: If the switch port configuration is changed to one of the fixed configuration options (for example, 100 Mbps/Full Duplex), then the port operates as MDI-X only and you must use the correct type of cable for the connection. In general, for connecting an end node (MDI port) to the switch, use straight-through cable; for connecting to MDI-X ports on hubs, other switches, and routers, use crossover cable.</p> <hr/> <ul style="list-style-type: none">– For fiber-optic connections, verify the transmit port on the switch is connected to the receive port on the connected device, and the switch receive port is connected to the transmit port on the connected device.• For the dual-personality 10/100/1000-T ports, be sure an SFP (mini-GBIC) transceiver is not installed in the associated slot.• For 1000Base-T connections, verify that the network cabling complies with the IEEE 802.3ab standard. the cable should be installed according to the ANSI/TIA/EIA-568-A-5 specifications. Cable testing should comply with the stated limitations for Attenuation, Near-End Crosstalk, Far-End Crosstalk, Equal-Level Far-End Crosstalk (ELFEXT), Multiple Disturber ELFEXT, and Return Loss.<p>The cable verification process must include all patch cables from any end devices, including the switch, to any patch panels in the cabling path.</p>• Verify the port has not been disabled through a switch configuration change. You can use the console interface, or, if you have configured an IP address on the switch, use the web browser interface, or ProCurve Manager network management software to determine the state of the port and re-enable the port if necessary.• Verify the switch port configuration matches the configuration of the attached device. For example, if the switch port is configured as “Auto”, the port on the attached device also MUST be configured as “Auto”. Depending on the port type, twisted-pair or fiber-optic, if the configurations don’t match, the results could be a very unreliable connection, or no link at all.• If the other procedures don’t resolve the problem, try using a different port or a different cable.

Tip	Problem	Solution
7	The port may be improperly configured, or the port may be in a “blocking” state by the normal operation of the Spanning Tree, LACP, or IGMP features.	<p>Use the switch console to see if the port is part of a dynamic trunk (through the LACP feature) or to see if Spanning Tree is enabled on the switch, and to see if the port may have been put into a “blocking” state by those features. The show lacp command displays the port status for the LACP feature; the show spanning-tree command displays the port status for Spanning Tree.</p> <p>Also check the Port Status screen using the show interfaces command to see if the port has been configured as “disabled”.</p> <p>Other switch features that may affect the port operation include VLANs and IGMP. Use the switch console to see how the port is configured for these features.</p> <p>For software troubleshooting tips, see the chapter “Troubleshooting” in the <i>Management and Configuration Guide</i>, which is on the ProCurve Web site at www.procurve.com/manuals.</p> <p>Make sure also, the device at the other end of the connection is indicating a good link to the switch. If it is not, the problem may be with the cabling between the devices or the connectors on the cable.</p>
8	A power supply has failed in a multi-power supply switch.	Check the back of the switch to see which power supply has failed. The failed power supply LED will be blinking. Replace the failed power supply. Once the failed power supply is removed the LEDs will return to normal. If only one supply is inserted, try power cycling the switch. If the fault reoccurs, the power supply may need to be replaced. If there are two power supplies inserted but only one is connected, to remove the fault either connect power to the other supply or remove it.
9	The switch has overheated.	Check to ensure the fans are functioning correctly.

Proactive Networking

The HP ProCurve 6600 Switches have built-in management capabilities that proactively help you manage your network including:

- finding and helping you fix the most common network error conditions (for example, faulty network cabling, and non-standard network topologies)
- informing you of the problem with clear, easy-to-understand messages
- recommending network configuration changes to enhance the performance of your network

The following interfaces provide tests, indicators, and an event log that can be used to monitor the switch and its network connections and to help you take advantage of these proactive networking features:

- ProCurve Manager - an SNMP-based network management tool that is included with your switch.
- A graphical web browser interface that you can use to manage your switch from a PC running a supported web browser, for example Microsoft Internet Explorer, and Netscape Communicator.
- A full-featured easy-to-use console interface that you can access by connecting a standard terminal or PC running a terminal emulator to the switch's console port. The cable to make that connection is provided with your switch. The console interface is also accessible through a Telnet connection.

For more information on using these software tools to diagnose and manage your switch, see the “Troubleshooting” chapter in the *Management and Configuration Guide*, which is on the ProCurve Web site at www.procurve.com/manuals.

Hardware Diagnostic Tests

Testing the Switch by Resetting It

If you believe the switch is not operating correctly, you can reset the switch to test its circuitry and operating code. To reset a switch, either:

- unplug and plug in the power cord (power cycling)
- press the Reset button on the front of the switch

Power cycling the switch and pressing the Reset button both cause the switch to perform its power-on self-test, which almost always will resolve any temporary operational problems. These reset processes also cause any network traffic counters to be reset to zero, and cause the System Up Time timer to reset to zero.

Checking the Switch LEDs

The self-test passes if the Fault and Self-Test LEDs on the front of the switch go off after approximately 50 seconds. If these LEDs stay on longer than 60 seconds or begin Blinking, there may be a problem with the switch.

See “Diagnosing With the LEDs” on [page 5-4](#) for information on interpreting the LED patterns and LED behaviors in chapter one.

Checking Console Messages

Useful diagnostic messages may be displayed on the console screen when the switch is reset. As described in chapter 2 under step 7, “Connect a Console to the Switch”, connect a PC running a VT-100 terminal emulator program or a standard VT-100 terminal to the switch’s Console Port and configure it to run at 9600 baud, and with the other terminal communication settings shown on [page 2-29](#). Then, when you reset the switch, note the messages that are displayed. Additionally, you can check the switch event log, which can be accessed from the console using the **show log** command, or from the console Main Menu.

Testing Twisted-Pair Cabling

Network cables that fail to provide a link or provide an unreliable link between the switch and the connected network device may not be compatible with the IEEE 802.3 Type 10Base-T, 100Base-TX, or 1000Base-T standards. The twisted-pair cables attached to the Switch must be compatible with the appropriate standards. To verify your cable is compatible with these standards, use a qualified cable test device.

Testing Switch-to-Device Network Communications

You can perform the following communication tests to verify the network is operating correctly between the switch and any connected device that can respond correctly to the communication test.

- Link Test – a physical layer test that sends IEEE 802.2 test packets to any device identified by its MAC address.
- Ping Test – a network layer test used on IP networks that sends test packets to any device identified by its IP address.

These tests can be performed through the switch console interface from a terminal connected to the switch or through a Telnet connection, or from the switch's web browser interface. For more information, see the *Management and Configuration Guide*, which is on the ProCurve Web site at www.procurve.com/manuals.

These tests can also be performed from an SNMP network management station running a program that can manage the switch, for example, ProCurve Manager.

Testing End-to-End Network Communications

Both the switch and the cabling can be tested by running an end-to-end communications test – a test that sends known data from one network device to another through the switch. For example, if you have two PCs on the network that have LAN adapters between which you can run a link-level test or Ping test through the switch, you can use this test to verify that the entire communication path between the two PCs is functioning correctly. See your LAN adapter documentation for more information on running a link test or Ping test.

Restoring the Factory Default Configuration

As part of your troubleshooting process on the switch, it may become necessary to return the switch configuration to the factory default settings. This process momentarily interrupts the switch operation, clears any passwords, clears the console event log, resets the network counters to zero, performs a complete self-test, and reboots the switch into its factory default configuration including deleting the IP address, if one is configured.

Note

This process removes all switch configuration changes you have made from the factory default settings. This includes, for example, configuration of VLANs, Spanning Tree, trunks, and stacking. Returning the configuration of these features to their factory default settings (usually disabling them) may result in network connectivity issues.

If the switch has a valid configuration, and you are restoring the factory default settings for a reason other than configuration problems, you should save the switch configuration prior to performing the factory default reset. Then, after the reset and resolution of the original problem, you can restore the saved configuration to the switch. For both the save and restore processes, you can use the console **copy** command. For more information on this command, see the *Management and Configuration Guide*, which is on the ProCurve Web site at www.procurve.com/manuals.

You can restore the factory default configuration either on the switch itself, or through the switch console.

To execute the factory default reset on the switch, perform these steps:

1. Using pointed objects, simultaneously press both the Reset and Clear buttons on the front of the switch.
2. Continue to press the Clear button while releasing the Reset button.
3. When the Self-Test LED begins to blink, release the Clear button.

The switch will then complete its self-test and begin operating with its configuration restored to the factory default settings.

To restore the factory default configuration using the console, execute the **erase startup-config** command from the console command prompt.

Downloading New Switch Software

When product enhancements occur for the switch, new software can be downloaded to the switch through several methods, for product enhancements and new features. For more information, see the *Management and Configuration Guide*, which is on the ProCurve Web site at www.procurve.com/manuals

The new switch software would be available on the ProCurve Web site at www.procurve.com/software.

HP Customer Support Services

If you are still having trouble with your switch, Hewlett-Packard offers support 24 hours a day, seven days a week through the use of a number of automated electronic services. See the Customer Support/Warranty booklet that came with your switch for information on how to use these services to get technical support. The ProCurve Web site at www.procurve.com/support also provides up-to-date support information.

Additionally, your ProCurve authorized network reseller can provide you with assistance, both with services that they offer and with services offered by ProCurve.

Before Calling Support

Before calling your networking dealer or ProCurve Support, to make the support process most efficient, you first should have retrieved the following information:

Information Item	Information Location
• product identification, including transceiver type	the front of the switch and on labels on the transceivers
• details about the switch's status including the software (OS) version, a copy of the switch configuration, a copy of the switch Event Log, and a copy of the switch status and counters information	switch console: show tech command
• copy of your network topology map, including network addresses assigned to the relevant devices	your network records

Specifications

Physical

HP ProCurve 6600 Switches	6600-24G (J9263A)	6600-24G-4XG (J9264A)	6600-24XG (J9265A)	6600-48G (J9451A)	6600-48G-4XG (J9452A)
Width:	44.3 cm (17.42 in)	44.3 cm (17.42 in)	44.3 cm (17.42 in)	44.25cm (17.42 in)	44.25cm (17.42 in)
Depth:	51.1 cm (20.1 in)	51.1 cm (20.1 in)	59.9 cm (23.6 in)	60.00cm (23.62 in)	60.00cm (23.62 in)
Height:	4.4 cm (1.7 in)	4.4 cm (1.7 in)	4.4 cm (1.7 in)	4.36cm (1.72 in)	4.36cm (1.72 in)
Weight:	7.68 kg (16.93 lbs)	7.7 kg (16.97 lbs)	9.33 kg (20.6 lbs)	9.33 kg (20.6 lbs)	9.40kg (20.72 lbs)

Electrical

The switch automatically adjusts to any voltage between 100-127 and 200-240 volts and either 50 or 60 Hz.

HP ProCurve 6600 Switches	6600-24G (J9263A)	6600-24G-4XG (J9264A)	6600-24XG (J9265A)	6600-48G (J9451A)	6600-48G-4XG (J9452A)
Electrical					
AC voltage:	100-127/200-240 volts	100-127/200-240 volts	100-127/200-240 volts	100-127/200-240 volts	100-127/200-240 volts
Maximum current:	1.8A/0.9A	2.1A/1.1A	4.2A/2.2A	3.0A/1.6A	3.0A/1.6A
Frequency range:	50/60 Hz	50/60 Hz	50/60 Hz	50/60 Hz	50/60 Hz

The switch automatically adjusts to any voltage between 100-127 and 200-240 volts and either 50 or 60 Hz.

Environmental

HP ProCurve 6600 Switches	Operating	Non-Operating
Temperature:	5°C to 40°C (41°F to 104°F)	-40°C to 70°C (-40°F to 158°F)
Relative humidity: (non-condensing)	15% to 80% at 40°C (104°F)	20% to 90% at 70°C (158°F)
Maximum altitude:	3.0 km (10,000 ft)	4.6 km (15,000 ft)

Acoustic

HP ProCurve Switch 6600-24G (J9263A)

Geraeuschemission $L_{pA}=62.3$ dB am fiktiven Arbeitsplatz nach DIN 45635 T.19

Noise Emission $L_{pA}=62.3$ dB at virtual workspace according to DIN 45635 T.19

HP ProCurve Switch 6600-28G-4XG (J9264A)

Geraeuschemission $L_{pA}=59.5$ dB am fiktiven Arbeitsplatz nach DIN 45635 T.19

Noise Emission $L_{pA}=59.5$ dB at virtual workspace according to DIN 45635 T.19

HP ProCurve Switch 6600-24G-24XG (J9265A)

Geraeuschemission $L_{pA}=61.8$ dB am fiktiven Arbeitsplatz nach DIN 45635 T.19

Noise Emission $L_{pA}=61.8$ dB at virtual workspace according to DIN 45635 T.19

HP ProCurve Switch 6600-48G (J9451A)

Geraeuschemission $L_{pA}=64.5$ dB am fiktiven Arbeitsplatz nach DIN 45635 T.19

Noise Emission $L_{pA}=64.5$ dB at virtual workspace according to DIN 45635 T.19

HP ProCurve Switch 6600-48G-4XG (J9452A)

Geraeuschemission $L_{pA}=63.4$ dB am fiktiven Arbeitsplatz nach DIN 45635 T.19

Noise Emission $L_{pA}=63.4$ dB at virtual workspace according to DIN 45635 T.19

Safety

Complies with:

- EN60950-1
- CSA 22.2 No. 60950-1
- UL 60950-1
- IEC 60950-1

Table A-1. Technology standards and safety compliance

Technology	Compatible with these IEEE standards	Laser safety information		
		Safety standard compliance	SFP ("mini-GBIC") Lasers	SFP+ Lasers
10/100/1000-T	IEEE 802.3 10BASE-T, IEEE 802.3u 100BASE-TX, IEEE 802.3ab 1000BASE-T			
100-FX	IEEE 802.3u 100BASE-FX	EN/IEC 60825	Class 1 Laser Product Laser Klasse 1	
100-BX	IEEE 802.3ah 100BASE-BX10	EN/IEC 60825	Class 1 Laser Product Laser Klasse 1	
1000-SX	IEEE 802.3z 1000BASE-SX	EN/IEC 60825	Class 1 Laser Product Laser Klasse 1	
1000-LX	IEEE 802.3z 1000BASE-LX	EN/IEC 60825	Class 1 Laser Product Laser Klasse 1	
1000-LH	(not an IEEE standard)	EN/IEC 60825	Class 1 Laser Product Laser Klasse 1	
1000-BX	IEEE 802.3ah 1000BASE-BX10	EN/IEC 60825	Class 1 Laser Product Laser Klasse 1	
10-Gig Direct Attach	(not an IEEE standard)			
10-Gig SR	IEEE 802.3ae 10GBASE-SR	EN/IEC 60825		Class 1 Laser Product Laser Klasse 1
10-Gig LRM	IEEE 802.3aq 10GBASE-LRM	EN/IEC 60825		Class 1 Laser Product Laser Klasse 1
10-Gig LR	IEEE 802.3ae 10GBASE-LR	EN/IEC 60825		Class 1 Laser Product Laser Klasse 1

Specifications

Cabling and Technology Information

This appendix includes network cable information for cables that should be used with the Switch 6600, including minimum pin-out information and specifications for twisted-pair cables.

Note

Incorrectly wired cabling is the most common cause of problems for LAN communications. ProCurve recommends that you work with a qualified LAN cable installer for assistance with your cabling requirements.

Cabling specifications

Table B-1.

Twisted-pair copper	10 Mbps Operation	Category 3, 4, or 5 100-ohm unshielded twisted-pair (UTP) or shielded twisted-pair (STP) cable, complying with IEEE 802.3 10Base-T specifications.
	100 Mbps Operation	Category 5 100-ohm UTP or STP cable, complying with IEEE 802.3u 100Base-TX specifications.
	1000 Mbps Operation	Category 5 100-ohm 4-pair UTP or STP cable, complying with IEEE 802.3ab 1000Base-T specifications—Category 5e or better is recommended. See note on 1000Base-T Cable Requirements on page B-2 .
Twiaxial copper	Direct attach cables	One-piece devices consisting of a cable with SFP+ connectors permanently attached to each end, complying with SFF 8431 SFP+ specifications.
Multimode fiber		62.5/125 μm or 50/125 μm (core/cladding) diameter, low metal content, graded index fiber-optic cables, complying with the ITU-T G.651 and ISO/IEC 793-2 Type A1b or A1a standards respectively. ¹
Single mode fiber		9/125 μm (core/cladding) diameter, low metal content fiber-optic cables, complying with the ITU-T G.652 and ISO/IEC 793-2 Type B1 standards.

¹ A mode conditioning patch cord may be needed for some Gigabit-LX and 10-Gigabit LRM installations. See [“Mode Conditioning Patch Cord” on page B-4](#) for more information.

Note on 1000Base-T Cable Requirements. The Category 5 networking cables that work for 100Base-TX connections should also work for 1000Base-T, as long as all four-pairs are connected. But, for the most robust connections you should use cabling that complies with the Category 5e specifications, as described in Addendum 5 to the TIA-568-A standard (ANSI/TIA/EIA-568-A-5).

Because of the increased speed provided by 1000Base-T (Gigabit-T), network cable quality is more important than for either 10Base-T or 100Base-TX. Cabling plants being used to carry 1000Base-T networking must comply with the IEEE 802.3ab standards. In particular, the cabling must pass tests for Attenuation, Near-End Crosstalk (NEXT), and Far-End Crosstalk (FEXT). Additionally, unlike the cables for 100Base-TX, the 1000Base-T cables must pass tests for Equal-Level Far-End Crosstalk (ELFEXT) and Return Loss.

When testing your cabling, be sure to include the patch cables that connect the switch and other end devices to the patch panels on your site. The patch cables are frequently overlooked when testing cable and they must also comply with the cabling standards.

Technology distance specifications

Table B-2.

Technology	Supported cable type	Multimode fiber modal bandwidth	Supported distances
100-FX	multimode fiber	any	up to 2,000 meters
100-BX	single mode fiber	N/A	0.5 - 10,000 meters
1000-T	twisted-pair copper	N/A	up to 100 meters
1000-SX	multimode fiber	160 MHz*km	2 - 220 meters
		200 MHz*km	2 - 275 meters
		400 MHz*km	2 - 500 meters
		500 MHz*km	2 - 550 meters
1000-LX	multimode fiber	400 MHz*km	2 - 550 meters
	single mode fiber	500 MHz*km	2 - 550 meters
		N/A	2 - 10,000 meters
1000-LH	single mode fiber	N/A	10 - 70,000 meters ¹
1000-BX	single mode fiber	N/A	0.5 - 10,000 meters
10-Gig Direct Attach	twinaxial copper	N/A	(various lengths offered)
10-Gig SR	multimode fiber	160 MHz*km	2 - 26 meters
		200 MHz*km	2 - 33 meters
		400 MHz*km	2 - 66 meters
		500 MHz*km	2 - 82 meters
		2000 MHz*km	2 - 300 meters
10-Gig LRM	multimode fiber	400 MHz*km	0.5 - 100 meters
		500 MHz*km	0.5 - 220 meters
10-Gig LR	single mode fiber	N/A	2 - 10,000 meters

¹ For distances less than 20km, a 10dB attenuator must be used. For distances between 20km and 40km, a 5dB attenuator must be used. Attenuators can be purchased from most cable vendors.

Mode Conditioning Patch Cord

The following information applies to installations in which multimode fiber-optic cables are connected to a Gigabit-LX port or a 10-Gigabit LRM port. Multimode cable has a design characteristic called “Differential Mode Delay”, which requires the transmission signals be “conditioned” to compensate for the cable design and thus prevent resulting transmission errors.

Under certain circumstances, depending on the cable used and the lengths of the cable runs, an external Mode Conditioning Patch Cord may need to be installed between the Gigabit-LX or 10-Gigabit LRM transmitting device and the multimode network cable to provide the transmission conditioning. If you experience a high number of transmission errors on those ports, usually CRC or FCS errors, you may need to install one of these patch cords between the fiber-optic port in your switch and your multimode fiber-optic network cabling, at both ends of the network link.

The patch cord consists of a short length of single mode fiber cable coupled to graded-index multimode fiber cable on the transmit side, and only multimode cable on the receive side. The section of single mode fiber is connected in such a way that it minimizes the effects of the differential mode delay in the multimode cable.

Note

Most of the time, if you are using good quality graded-index multimode fiber cable that adheres to the standards listed in Appendix B, there should not be a need to use mode conditioning patch cords in your network. This is especially true if the fiber runs in your network are relatively short.

For 10-Gigabit LRM using OM3 cable (50 μ m multimode @ 1500/500 MHz*km), a mode conditioning patch cord is not required. Other multimode cables may require mode conditioning patch cords to achieve the LRM maximum distances.

Installing the Patch Cord

As shown in the illustration below, connect the patch cord to the ProCurve transceiver with the section of single mode fiber plugged in to the Tx (transmit) port. Then, connect the other end of the patch cord to your network cabling patch panel, or directly to the network multimode fiber.

If you connect the patch cord directly to the network cabling, you may need to install a female-to-female adapter to allow the cables to be connected together.

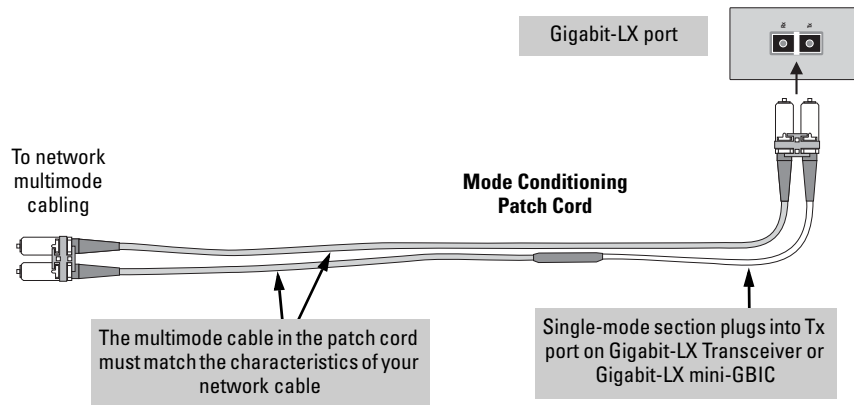

Figure B-1. Example: Connecting a Mode Conditioning Patch Cord for Gigabit-LX

Make sure you purchase a patch cord that has appropriate connectors on each end, and has multimode fibers that match the characteristics of the multimode fiber in your network. Most important, the core diameter of the multimode patch cord must match the core diameter of the multimode cable infrastructure (either 50 or 62.5 microns).

Twisted-Pair Cable/Connector Pin-Outs

Auto-MDIX Feature: The 10/100/1000-T ports support the IEEE 802.3ab standard, which includes the “Auto MDI/MDI-X” feature. In the default configuration, “Auto”, the ports on the Switch 6600 all automatically detect the type of port on the connected device and operate as either an MDI or MDI-X port, whichever is appropriate. So for any connection, a straight-through twisted-pair cable can be used – *you no longer have to use crossover cables*, although crossover cables can also be used for any of the connections.

If you connect a Switch 6600 twisted-pair port to another switch or hub, which typically have MDI-X ports, the Switch 6600 port automatically operates as an MDI port. If you connect it to an end node, such as a server or PC, which typically have MDI ports, the Switch 6600 port operates as an MDI-X port. In all cases, you can use standard straight-through cables or crossover cables.

If you happen to use a correctly wired crossover cable, though, the switch will still be able to automatically detect the MDI/MDI-X operation and link correctly to the connected device.

Other Wiring Rules:

- All twisted-pair wires used for 10 Mbps, and 100 Mbps operation must be twisted through the entire length of the cable. The wiring sequence must conform to EIA/TIA 568-B (not USOC). See “Twisted-Pair Cable Pin Assignments” later in this appendix for a listing of the signals used on each pin.
- For 1000Base-T connections, all four pairs of wires in the cable must be available for data transmission. See [“Note on 1000Base-T Cable Requirements” on page B-2](#) for more information on 1000Base-T cabling.
- For 10 Mbps connections to the ports, you can use Category 3, 4, or 5 unshielded twisted-pair cable, as supported by the IEEE 802.3 Type 10Base-T standard.
- For 100 Mbps connections to the ports, use 100-ohm Category 5 UTP or STP cable only, as supported by the IEEE 802.3u Type 100Base-TX standard.
- For 1000 Mbps connections, 100-ohm Category 5e or better cabling is recommended.

Straight-Through Twisted-Pair Cable for 10 Mbps or 100 Mbps Network Connections

Because of the HP Auto-MDIX operation of the 10/100 ports on the switch, for all network connections, to PCs, servers or other end nodes, or to hubs or other switches, you can use straight-through cables.

If any of these ports are given a fixed configuration, for example 100 Mbps/ Full Duplex, the ports operate as MDI-X ports, and straight-through cables must be then used for connections to PC NICs and other MDI ports.

Cable Diagram

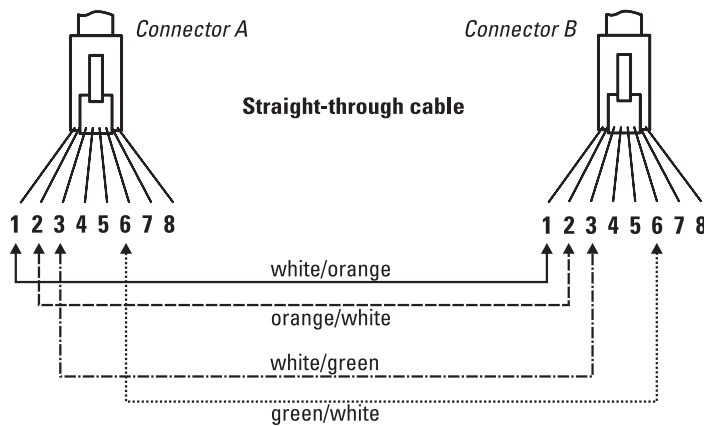

Note

Pins 1 and 2 on connector “A” *must* be wired as a twisted pair to pins 1 and 2 on connector “B”.
 Pins 3 and 6 on connector “A” *must* be wired as a twisted pair to pins 3 and 6 on connector “B”.
 Pins 4, 5, 7, and 8 are not used in this application, although they may be wired in the cable.

Pin Assignments

Switch End (MDI-X)		Computer, Transceiver, or Other End		
Signal	Pins	Pins	Signal	
receive +	1	←————→	1	transmit +
receive -	2	←————→	2	transmit -
transmit +	3	————→	3	receive +
transmit -	6	————→	6	receive -

Crossover Twisted-Pair Cable for 10 Mbps or 100 Mbps Network Connection

The HP Auto-MDIX operation of the 10/100 ports on the switch also allows you to use crossover cables for all network connections, to PCs, servers or other end nodes, or to hubs or other switches.

If any of these ports are given a fixed configuration, for example 100 Mbps/ Full Duplex, the ports operate as MDI-X ports, and crossover cables *must* be then used for connections to hubs or switches or other MDI-X network devices.

Cable Diagram

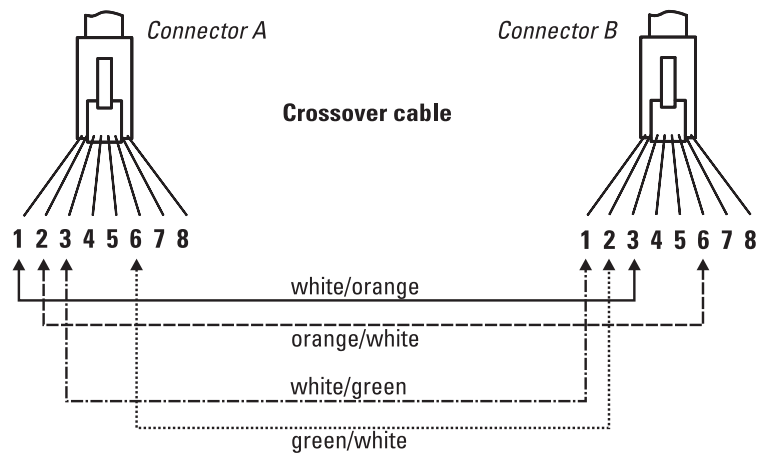

Note

Pins 1 and 2 on connector “A” *must* be wired as a twisted pair to pins 3 and 6 on connector “B”.

Pins 3 and 6 on connector “A” *must* be wired as a twisted pair to pins 1 and 2 on connector “B”.

Pins 4, 5, 7, and 8 are not used in this application, although they may be wired in the cable.

Pin Assignments

Switch End (MDI-X)		Hub or Switch Port, or Other MDI-X Port End	
Signal	Pins	Pins	Signal
receive +	1	6	transmit -
receive -	2	3	transmit +
transmit +	3	2	receive -
transmit -	6	1	receive +

Straight-Through Twisted-Pair Cable for 1000 Mbps Network Connections

1000Base-T connections require that all four pairs or wires be connected.

Cable Diagram

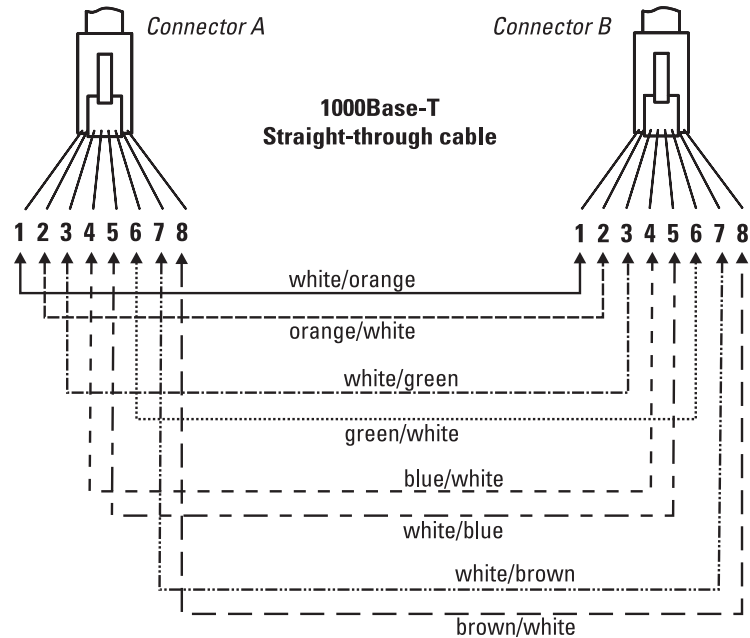

Note

Pins 1 and 2 on connector “A” *must* be wired as a twisted pair to pins 1 and 2 on connector “B”.

Pins 3 and 6 on connector “A” *must* be wired as a twisted pair to pins 3 and 6 on connector “B”.

Pins 4 and 5 on connector “A” *must* be wired as a twisted pair to pins 4 and 5 on connector “B”.

Pins 7 and 8 on connector “A” *must* be wired as a twisted pair to pins 7 and 8 on connector “B”.

Pin Assignments

For 1000Base-T operation, all four pairs of wires are used for both transmit and receive.

Safety and EMC Regulatory Statements

Safety Information



Documentation reference symbol. If the product is marked with this symbol, refer to the product documentation to get more information about the product.

WARNING

A **WARNING** in the manual denotes a hazard that can cause injury or death.

Caution

A Caution in the manual denotes a hazard that can damage equipment.

Do not proceed beyond a **WARNING** or Caution notice until you have understood the hazardous conditions and have taken appropriate steps.

Grounding

These are safety class I products and have protective earthing terminals. There must be an uninterruptible safety earth ground from the main power source to the product's input wiring terminals, power cord, or supplied power cord set. Whenever it is likely that the protection has been impaired, disconnect the power cord until the ground has been restored.

For LAN cable grounding:

- If your LAN covers an area served by more than one power distribution system, be sure their safety grounds are securely interconnected.
- LAN cables may occasionally be subject to hazardous transient voltages (such as lightning or disturbances in the electrical utilities power grid). Handle exposed metal components of the network with caution.

Servicing

There are no user-serviceable parts inside these products. Any servicing, adjustment, maintenance, or repair must be performed only by service-trained personnel.

These products do not have a power switch; they are powered on when the power cord is plugged in.

Informations concernant la sécurité



Symbole de référence à la documentation. Si le produit est marqué de ce symbole, reportez-vous à la documentation du produit afin d'obtenir des informations plus détaillées.

WARNING

Dans la documentation, un **WARNING** indique un danger susceptible d'entraîner des dommages corporels ou la mort.

Caution

Un texte de mise en garde intitulé Caution indique un danger susceptible de causer des dommages à l'équipement.

Ne continuez pas au-delà d'une rubrique **WARNING** ou Caution avant d'avoir bien compris les conditions présentant un danger et pris les mesures appropriées.

Cet appareil est un produit de classe I et possède une borne de mise à la terre. La source d'alimentation principale doit être munie d'une prise de terre de sécurité installée aux bornes du câblage d'entrée, sur le cordon d'alimentation ou le cordon de raccordement fourni avec le produit. Lorsque cette protection semble avoir été endommagée, débrancher le cordon d'alimentation jusqu'à ce que la mise à la terre ait été réparée.

Mise à la terre du câble de réseau local:

- si votre réseau local s'étend sur une zone desservie par plus d'un système de distribution de puissance, assurez-vous que les prises de terre de sécurité soient convenablement interconnectées.
- Les câbles de réseaux locaux peuvent occasionnellement être soumis à des surtensions transitoires dangereuses (telles que la foudre ou des perturbations dans le réseau d'alimentation public). Manipulez les composants métalliques du réseau avec précautions.

Aucune pièce contenue à l'intérieur de ce produit ne peut être réparée par l'utilisateur. Tout dépannage, réglage, entretien ou réparation devra être confié exclusivement à un personnel qualifié.

Cet appareil ne comporte pas de commutateur principal ; la mise sous tension est effectuée par branchement du cordon d'alimentation.

Hinweise zur Sicherheit



Symbol für Dokumentationsverweis. Wenn das Produkt mit diesem Symbol markiert ist, schlagen Sie bitte in der Produktdokumentation nach, um mehr Informationen über das Produkt zu erhalten.

WARNING

Eine **WARNING** in der Dokumentation symbolisiert eine Gefahr, die Verletzungen oder sogar Todesfälle verursachen kann.

Caution

Caution in der Dokumentation symbolisiert eine Gefahr, die das Gerät beschädigen kann.

Fahren Sie nach dem Hinweis **WARNING** oder Caution erst fort, nachdem Sie den Gefahrenzustand verstanden und die entsprechenden Maßnahmen ergriffen haben.

Dies ist ein Gerät der Sicherheitsklasse I und verfügt über einen schützenden Erdungsterminal. Der Betrieb des Geräts erfordert eine ununterbrochene Sicherheitserdung von der Hauptstromquelle zu den Geräteingabeterminals, den Netzkabeln oder dem mit Strom belieferten Netzkabelsatz voraus. Sobald Grund zur Annahme besteht, daß der Schutz beeinträchtigt worden ist, das Netzkabel aus der Wandsteckdose herausziehen, bis die Erdung wiederhergestellt ist.

Für LAN-Kabelerdung:

- Wenn Ihr LAN ein Gebiet umfaßt, das von mehr als einem Stromverteilungssystem beliefert wird, müssen Sie sich vergewissern, daß die Sicherheitserdungen fest untereinander verbunden sind.
- LAN-Kabel können gelegentlich gefährlichen Übergangsspannungen ausgesetzt werden (beispielsweise durch Blitz oder Störungen in dem Starkstromnetz des Elektrizitätswerks). Bei der Handhabung exponierter Metallbestandteile des Netzwerkes Vorsicht walten lassen.

Dieses Gerät enthält innen keine durch den Benutzer zu wartenden Teile. Wartungs-, Anpassungs-, Instandhaltungs- oder Reparaturarbeiten dürfen nur von geschultem Bedienungspersonal durchgeführt werden.

Dieses Gerät hat keinen Netzschalter; es wird beim Anschließen des Netzkabels eingeschaltet.

Considerazioni sulla sicurezza



WARNING

Simbolo di riferimento alla documentazione. Se il prodotto è contrassegnato da questo simbolo, fare riferimento alla documentazione sul prodotto per ulteriori informazioni su di esso.

Caution

La dicitura **WARNING** denota un pericolo che può causare lesioni o morte.

La dicitura **Caution** denota un pericolo che può danneggiare le attrezzature.

Non procedere oltre un avviso di **WARNING** o di **Caution** prima di aver compreso le condizioni di rischio e aver provveduto alle misure del caso.

Questo prodotto è omologato nella classe di sicurezza I ed ha un terminale protettivo di collegamento a terra. Dev'essere installato un collegamento a terra di sicurezza, non interrompibile che vada dalla fonte d'alimentazione principale ai terminali d'entrata, al cavo d'alimentazione oppure al set cavo d'alimentazione fornito con il prodotto. Ogniqualvolta vi sia probabilità di danneggiamento della protezione, disinserite il cavo d'alimentazione fino a quando il collegamento a terra non sia stato ripristinato.

Per la messa a terra dei cavi LAN:

- se la vostra LAN copre un'area servita da più di un sistema di distribuzione elettrica, accertatevi che i collegamenti a terra di sicurezza siano ben collegati fra loro;
- i cavi LAN possono occasionalmente andare soggetti a pericolose tensioni transitorie (ad esempio, provocate da lampi o disturbi nella griglia d'alimentazione della società elettrica); siate cauti nel toccare parti esposte in metallo della rete.

Nessun componente di questo prodotto può essere riparato dall'utente. Qualsiasi lavoro di riparazione, messa a punto, manutenzione o assistenza va effettuato esclusivamente da personale specializzato.

Questo apparato non possiede un commutatore principale; si mette scotto tensione all'inserirsi il cavo d'alimentazione.

Consideraciones sobre seguridad



Símbolo de referencia a la documentación. Si el producto va marcado con este símbolo, consultar la documentación del producto a fin de obtener mayor información sobre el producto.

WARNING

Una **WARNING** en la documentación señala un riesgo que podría resultar en lesiones o la muerte.

Caution

Una Caution en la documentación señala un riesgo que podría resultar en averías al equipo.

No proseguir después de un símbolo de **WARNING** o Caution hasta no haber entendido las condiciones peligrosas y haber tomado las medidas apropiadas.

Este aparato se enmarca dentro de la clase I de seguridad y se encuentra protegido por una borna de puesta a tierra. Es preciso que exista una puesta a tierra continua desde la toma de alimentación eléctrica hasta las bornas de los cables de entrada del aparato, el cable de alimentación o el juego de cable de alimentación suministrado. Si existe la probabilidad de que la protección a tierra haya sufrido desperfectos, desenchufar el cable de alimentación hasta haberse subsanado el problema.

Puesta a tierra del cable de la red local (LAN):

- Si la LAN abarca un área cuyo suministro eléctrico proviene de más de una red de distribución de electricidad, cerciorarse de que las puestas a tierra estén conectadas entre sí de modo seguro.
- Es posible que los cables de la LAN se vean sometidos de vez en cuando a voltajes momentáneos que entrañen peligro (rayos o alteraciones en la red de energía eléctrica). Manejar con precaución los componentes de metal de la LAN que estén al descubierto.

Este aparato no contiene pieza alguna susceptible de reparación por parte del usuario. Todas las reparaciones, ajustes o servicio de mantenimiento debe realizarlos solamente el técnico.

Este producto no tiene interruptor de potencia; se activa cuando se enchufa el cable de alimentación.

Safety Information (Japan)

安全性の考慮

安全記号



マニュアル参照記号。製品にこの記号がついている場合はマニュアルを参照し、注意事項等をご確認ください。

WARNING マニュアル中の「WARNING」は人身事故の原因となる危険を示します。

CAUTION マニュアル中の「CAUTION」は装置破損の原因となる危険を示します。

「WARNING」や「CAUTION」の項は飛ばさないで必ずお読みください。危険性に関する記載事項をよく読み、正しい手順に従った上で次の事項に進んでください。

これは安全性クラス I の製品で保護用接地端子を備えています。主電源から製品の入力配線端子、電源コード、または添付の電源コード・セットまでの間、切れ目のない安全接地が存在することが必要です。もしこの保護回路が損なわれたことが推測されるときは、接地が修復されるまで電源コードを外しておいてください。

LAN ケーブルの接地に関して:

- もし貴社の LAN が複数の配電システムにより電力を受けている領域をカバーしている場合には、それらのシステムの安全接地が確実に相互に結合されていることを確認してください。
- LAN ケーブルは時として危険な過度電圧（例えば雷や、配電設備の電力網での障害）にさらされることがあります。露出した金属部分の取扱いには十分な注意をはらってください。

本製品の内部にはユーザーが修理できる部品はありません。サービス、調整、保守および修理はサービス訓練を受けた専門家におまかせください。

本製品には電源スイッチがありません。電源コードを接続したとき電源入となります。

**Japan Power
Cord Warning**

製品には、同梱された電源コードをお使い下さい。
同梱された電源コードは、他の製品では使用出来ません。

Safety Information (China)

HP 网络产品使用安全手册

使用须知

欢迎使用惠普网络产品，为了您及仪器的安全，请您务必注意如下事项：

1. 仪器要和地线相接，要使用有正确接地插头的电源线，使用中国国家规定的220V电源。
2. 避免高温和尘土多的地方，否则易引起仪器内部部件的损坏。
3. 避免接近高温，避免接近直接热源，如直射阳光、暖气等其它发热体。
4. 不要有异物或液体落入机内，以免部件短路。
5. 不要将磁体放置于仪器附近。

警告

为防止火灾或触电事故，请不要将该机放置于淋雨或潮湿处。

安装

安装辅助管理模块，请参看安装指南。

保修及技术支持

如果您按照以上步骤操作时遇到了困难，或想了解其它产品性能，请按以下方式与我们联系。

如是硬件故障：

1. 与售出单位或当地维修机构联系。
2. 中国惠普有限公司维修中心地址：
北京市海淀区知春路49号希格玛大厦
联系电话：010-62623888 转 6101
邮政编码：100080

如是软件问题：

1. 惠普用户响应中心热线电话：010-65645959
2. 传真自动回复系统：010-65645735

EMC Regulatory Statements

U.S.A.

FCC Class A

This equipment has been tested and found to comply with the limits for a Class A digital device, pursuant to Part 15 of the FCC Rules. These limits are designed to provide reasonable protection against interference when the equipment is operated in a commercial environment. This equipment generates, uses, and can radiate radio frequency energy and, if not installed and used in accordance with the instruction manual, may cause interference to radio communications. Operation of this equipment in a residential area may cause interference in which case the user will be required to correct the interference at his own expense.

Canada

This product complies with Class A Canadian EMC requirements.

Australia/New Zealand



This product complies with Australia/New Zealand EMC Class A requirements.

Japan

VCCI Class A

この装置は、情報処理装置等電波障害自主規制協議会（VCCI）の基準に基づくクラスA情報技術装置です。この装置を家庭環境で使用すると電波妨害を引き起こすことがあります。この場合には使用者が適切な対策を講ずるよう要求されることがあります。

Korea



사용자 안내문 : A 급기기

이기는 업무용으로 전자파 적합등록을 받은 기기 이오니, 판매자 또는 사용자는 이점을 주의하시기 바라며, 만약 잘못 구입하셨을 때에는 구입한 곳에서 비업무용으로 교환하시기 바랍니다.

Taiwan

警告使用者：這是甲類的資訊產品，在居住的環境中使用時，可能會造成射頻干擾，在這種情況下，使用者會被要求採取某些適當的對策。

European Community

 DECLARATION OF CONFORMITY according to ISO/IEC 17050-1 and EN 17050-1	
DoC #: RSVLC-0704-030909	
Supplier's Name:	Hewlett-Packard Company
Manufacturer's Address:	8000 Foothills Blvd., Roseville, CA 95747 U.S.A.
declares, that the product	
Product Name²:	HP ProCurve 6600-24G HP ProCurve 6600-24G-4XG HP ProCurve 6600-24XG HP ProCurve 6600-48G HP ProCurve 6600-48G-4XG
Product Number(s):	J9263A, J9266A, J9264A, J9267A, J9265A, J9268A J9451A, J9452A
Regulatory Model No¹:	RSVLC-0704
Product Options:	J9269A – Power supply
conforms to the following Product Specifications and Regulations:	
EMC: Class A EN 55022:2006/CISPR 22: 2005 EN 55024:1998 + A1:2001 + A2:2003 EN 61000-3-2:2006 EN 61000-3-3:1995 + A1:2001 + A2:2005 FCC CFR47 Part 15	
Safety: EN 60950-1:2001 IEC 60950-1: 2001 EN 60825-1:1994 +A1+A2 / IEC 60825-1:1993 +A2 Class 1	
Supplementary Information: The device complies with part 15 of the FCC Rules. Operation is subject to the following two conditions: (1) this device may not cause harmful interference, and (2) this device must accept any interference received, including interference that may cause undesired operation. The product herewith complies with the requirements of the Low Voltage Directive 2006/95/EC, the EMC Directive 2004/108/EC and carries the CE marking accordingly.	
Additional Information: 1) This product is assigned a Regulatory Model Number which stays with the regulatory aspects of the design. The Regulatory Model Number is the main product identifier in the regulatory documentation and test reports, this number should not be confused with the marketing name or the product numbers. 2) This product was tested with HP branded products only.	
Roseville, 09 - March - 2009	 Michael E. Avery, Regulatory Eng. Manager
Local contact for regulatory information: EMEA: Hewlett-Packard GmbH, HQ-TRE, Herrenberger Straße 140, D-71034 Böblingen, Germany U.S.: Hewlett-Packard, 3000 Hanover St., Palo Alto, CA 94304, U.S.A. 650-857-1501	

Recycle Statements

Waste Electrical and Electronic Equipment (WEEE) Statements



Disposal of Waste Equipment by Users in Private Household in the European Union

This symbol on the product or on its packaging indicates that this product must not be disposed of with your other household waste. Instead, it is your responsibility to dispose of your waste equipment by handing it over to a designated collection point for the recycling of waste electrical and electronic equipment. The separate collection and recycling of your waste equipment at the time of disposal will help to conserve natural resources and ensure that it is recycled in a manner that protects human health and the environment. For more information about where you can drop off your waste equipment for recycling, please contact your local city office, your household waste disposal service or the shop where you purchased the product.



Likvidace zařízení soukromými domácími uživateli v Evropské unii

Tento symbol na produktu nebo balení označuje výrobek, který nesmí být vyhozen spolu s ostatním domácím odpadem. Povinností uživatele je předat takto označený odpad na předem určené sběrné místo pro recyklaci elektrických a elektronických zařízení. Okamžité třídění a recyklace odpadu pomůže uchovat přírodní prostředí a zajistí takový způsob recyklace, který ochrání zdraví a životní prostředí člověka. Další informace o možnostech odevzdání odpadu k recyklaci získáte na příslušném obecním nebo městském úřadě, od firmy zabývající se sběrem a svozem odpadu nebo v obchodě, kde jste produkt zakoupili.



Bortskaffelse af affald fra husstande i den Europæiske Union

Hvis produktet eller dets emballage er forsynet med dette symbol, angiver det, at produktet ikke må bortskaffes med andet almindeligt husholdningsaffald. I stedet er det dit ansvar at bortskaffe kasseret udstyr ved at aflevere det på den kommunale genbrugsstation, der forestår genvinding af kasseret elektrisk og elektronisk udstyr. Den centrale modtagelse og genvinding af kasseret udstyr i forbindelse med bortskaffelsen bidrager til bevarelse af naturlige ressourcer og sikrer, at udstyret genvindes på en måde, der beskytter både mennesker og miljø. Yderligere oplysninger om, hvor du kan aflevere kasseret udstyr til genvinding, kan du få hos kommunen, den lokale genbrugsstation eller i den butik, hvor du købte produktet.



Seadmete jäätmete kõrvaldamine eramajapidamistes Euroopa Liidus

See tootel või selle pakendil olev sümbol näitab, et kõnealust toodet ei tohi koos teiste majapidamisjäätmetega kõrvaldada. Teie kohus on oma seadmete jäätmed kõrvaldada, viies need elektri- ja elektroonikaseadmete jäätmete ringlussevõtmiseks selleks ettenähtud kogumispunkti. Seadmete jäätmete eraldi kogumine ja ringlussevõtmise kõrvaldamise ajal aitab kaitsta loodusvarasid ning tagada, et ringlussevõtmise toimub viisil, mis kaitseb inimeste tervist ning keskkonda. Lisateabe saamiseks selle kohta, kuhu oma seadmete jäätmed ringlussevõtmiseks viia, võtke palun ühendust oma kohaliku linna-kantselei, majapidamisjäätmete kõrvaldamise teenistuse või kauplusega, kust Te toote ostsite.

Recycle Statements

Waste Electrical and Electronic Equipment (WEEE) Statements



Laitteiden hävittäminen kotitalouksissa Euroopan unionin alueella

Jos tuotteessa tai sen pakkauksessa on tämä merkki, tuotetta ei saa hävittää kotitalousjätteiden mukana. Tällöin hävitettävä laite on toimitettava sähkölaitteiden ja elektronisten laitteiden kierrätyspisteeseen. Hävitettävien laitteiden erillinen käsittely ja kierrätys auttavat säästämään luonnonvaroja ja varmistamaan, että laite kierrätetään tavalla, joka estää terveyshaitat ja suojelee luontoa. Lisätietoja paikoista, joihin hävitettävät laitteet voi toimittaa kierrätettäväksi, saa ottamalla yhteyttä jätehuoltoon tai liikkeeseen, josta tuote on ostettu.



Élimination des appareils mis au rebut par les ménages dans l'Union européenne

Le symbole apposé sur ce produit ou sur son emballage indique que ce produit ne doit pas être jeté avec les déchets ménagers ordinaires. Il est de votre responsabilité de mettre au rebut vos appareils en les déposant dans les centres de collecte publique désignés pour le recyclage des équipements électriques et électroniques. La collecte et le recyclage de vos appareils mis au rebut indépendamment du reste des déchets contribue à la préservation des ressources naturelles et garantit que ces appareils seront recyclés dans le respect de la santé humaine et de l'environnement. Pour obtenir plus d'informations sur les centres de collecte et de recyclage des appareils mis au rebut, veuillez contacter les autorités locales de votre région, les services de collecte des ordures ménagères ou le magasin dans lequel vous avez acheté ce produit.



Entsorgung von Altgeräten aus privaten Haushalten in der EU

Das Symbol auf dem Produkt oder seiner Verpackung weist darauf hin, dass das Produkt nicht über den normalen Hausmüll entsorgt werden darf. Benutzer sind verpflichtet, die Altgeräte an einer Rücknahmestelle für Elektro- und Elektronik-Altgeräte abzugeben. Die getrennte Sammlung und ordnungsgemäße Entsorgung Ihrer Altgeräte trägt zur Erhaltung der natürlichen Ressourcen bei und garantiert eine Wiederverwertung, die die Gesundheit des Menschen und die Umwelt schützt. Informationen dazu, wo Sie Rücknahmestellen für Ihre Altgeräte finden, erhalten Sie bei Ihrer Stadtverwaltung, den örtlichen Müllentsorgungsbetrieben oder im Geschäft, in dem Sie das Gerät erworben haben



Απόρριψη άχρηστου εξοπλισμού από χρήστες σε ιδιωτικά νοικοκυριά στην Ευρωπαϊκή Ένωση

Το σύμβολο αυτό στο προϊόν ή τη συσκευασία του υποδεικνύει ότι το συγκεκριμένο προϊόν δεν πρέπει να διατίθεται μαζί με τα άλλα οικιακά σας απορρίμματα. Αντίθετα, είναι δική σας ευθύνη να απορρίψετε τον άχρηστο εξοπλισμό σας παραδίδοντάς τον σε καθορισμένο σημείο συλλογής για την ανακύκλωση άχρηστου ηλεκτρικού και ηλεκτρονικού εξοπλισμού. Η ξεχωριστή συλλογή και ανακύκλωση του άχρηστου εξοπλισμού σας κατά την απόρριψη θα συμβάλει στη διατήρηση των φυσικών πόρων και θα διασφαλίσει ότι η ανακύκλωση γίνεται με τρόπο που προστατεύει την ανθρώπινη υγεία και το περιβάλλον. Για περισσότερες πληροφορίες σχετικά με το πού μπορείτε να παραδώσετε τον άχρηστο εξοπλισμό σας για ανακύκλωση, επικοινωνήστε με το αρμόδιο τοπικό γραφείο, την τοπική υπηρεσία διάθεσης οικιακών απορριμμάτων ή το κατάστημα όπου αγοράσατε το προϊόν.



Készülékek magánháztartásban történő selejtezése az Európai Unió területén

A készüléken, illetve a készülék csomagolásán látható azonos szimbólum annak jelzésére szolgál, hogy a készülék a selejtezés során az egyéb háztartási hulladéktól eltérő módon kezelendő. A vásárló a hulladékká vált készüléket köteles a kijelölt gyűjtőhelyre szállítani az elektromos és elektronikai készülékek újrahasznosítása céljából. A hulladékká vált készülékek selejtezés kori begyűjtése és újrahasznosítása hozzájárul a természeti erőforrások megőrzéséhez, valamint biztosítja a selejtezett termékek környezetre és emberi egészségre nézve biztonságos feldolgozását. A begyűjtés pontos helyéről bővebb tájékoztatást a lakhelye szerint illetékes önkormányzattól, az illetékes személtakarító vállalattól, illetve a terméket eláruló helyen kaphat.



Smaltimento delle apparecchiature da parte di privati nel territorio dell'Unione Europea

Questo simbolo presente sul prodotto o sulla sua confezione indica che il prodotto non può essere smaltito insieme ai rifiuti domestici. È responsabilità dell'utente smaltire le apparecchiature consegnandole presso un punto di raccolta designato al riciclo e allo smaltimento di apparecchiature elettriche ed elettroniche. La raccolta differenziata e il corretto riciclo delle apparecchiature da smaltire permette di proteggere la salute degli individui e l'ecosistema. Per ulteriori informazioni relative ai punti di raccolta delle apparecchiature, contattare l'ente locale per lo smaltimento dei rifiuti, oppure il negozio presso il quale è stato acquistato il prodotto.



Nolietotu iekārtu iznīcināšanas noteikumi lietotājiem Eiropas Savienības privātajās mājāsaimniecībās

Šāds simbols uz izstrādājuma vai uz tā iesaiņojuma norāda, ka šo izstrādājumu nedrīkst izmest kopā ar citiem sadzīves atkritumiem. Jūs atbildat par to, lai nolietotās iekārtas tiktu nodotas speciāli iekārtotos punktos, kas paredzēti izmantoto elektrisko un elektronisko iekārtu savākšanai otrreizējai pārstrādei. Atsevišķa nolietoto iekārtu savākšana un otrreizējā pārstrāde palīdzēs saglabāt dabas resursus un garantēs, ka šīs iekārtas tiks otrreizēji pārstrādātas tādā veidā, lai pasargātu vidi un cilvēku veselību. Lai uzzinātu, kur nolietotās iekārtas var izmest otrreizējai pārstrādei, jāvērsas savas dzīves vietas pašvaldībā, sadzīves atkritumu savākšanas dienestā vai veikalā, kurā izstrādājums tika nopirkts.



Vartotojū iš privačių namų ūkių įrangos atliekų šalinimas Europos Sąjungoje

Šis simbolis ant gaminio arba jo pakuotės rodo, kad šio gaminio šalinti kartu su kitomis namų ūkio atliekomis negalima. Šalintinas įrangos atliekas privalote pristatyti į specialią surinkimo vietą elektros ir elektroninės įrangos atliekoms perdirbti. Atskirai surenkamos ir perdirbamos šalintinos įrangos atliekos padės saugoti gamtinius išteklius ir užtikrinti, kad jos bus perdirbtos tokiu būdu, kuris nekenkia žmonių sveikatai ir aplinkai. Jeigu norite sužinoti daugiau apie tai, kur galima pristatyti perdirbtinas įrangos atliekas, kreipkitės į savo seniūniją, namų ūkio atliekų šalinimo tarnybą arba parduotuvę, kurioje įsigijote gaminį.



Verwijdering van afgedankte apparatuur door privé-gebruikers in de Europese Unie

Dit symbool op het product of de verpakking geeft aan dat dit product niet mag worden gedeponeerd bij het normale huishoudelijke afval. U bent zelf verantwoordelijk voor het inleveren van uw afgedankte apparatuur bij een inzamelingspunt voor het recyclen van oude elektrische en elektronische apparatuur. Door uw oude apparatuur apart aan te bieden en te recyclen, kunnen natuurlijke bronnen worden behouden en kan het materiaal worden hergebruikt op een manier waarmee de volksgezondheid en het milieu worden beschermd. Neem contact op met uw gemeente, het afvalinzamelingsbedrijf of de winkel waar u het product hebt gekocht voor meer informatie over inzamelingspunten waar u oude apparatuur kunt aanbieden voor recycling.



Pozbywanie się zużytego sprzętu przez użytkowników w prywatnych gospodarstwach domowych w Unii Europejskiej

Ten symbol na produkcie lub jego opakowaniu oznacza, że produktu nie wolno wyrzucać do zwykłych pojemników na śmieci. Obowiązkiem użytkownika jest przekazanie zużytego sprzętu do wyznaczonego punktu zbiórki w celu recyklingu odpadów powstałych ze sprzętu elektrycznego i elektronicznego. Osobna zbiórka oraz recykling zużytego sprzętu pomogą w ochronie zasobów naturalnych i zapewnią ponowne wprowadzenie go do obiegu w sposób chroniący zdrowie człowieka i środowisko. Aby uzyskać więcej informacji o tym, gdzie można przekazać zużyty sprzęt do recyklingu, należy się skontaktować z urzędem miasta, zakładem gospodarki odpadami lub sklepem, w którym zakupiono produkt.

**Descarte de Lixo Elétrico na Comunidade Européia**

Este símbolo encontrado no produto ou na embalagem indica que o produto não deve ser descartado no lixo doméstico comum. É responsabilidade do cliente descartar o material usado (lixo elétrico), encaminhando-o para um ponto de coleta para reciclagem. A coleta e a reciclagem seletivas desse tipo de lixo ajudarão a conservar as reservas naturais; sendo assim, a reciclagem será feita de uma forma segura, protegendo o ambiente e a saúde das pessoas. Para obter mais informações sobre locais que reciclam esse tipo de material, entre em contato com o escritório da HP em sua cidade, com o serviço de coleta de lixo ou com a loja em que o produto foi adquirido.

**Likvidácia vyradených zariadení v domácnostiach v Európskej únii**

Symbol na výrobku alebo jeho balení označuje, že daný výrobok sa nesmie likvidovať s domovým odpadom. Povinnosťou spotrebiteľa je odovzdať vyradené zariadenie v zbernom mieste, ktoré je určené na recykláciu vyradených elektrických a elektronických zariadení. Separovaný zber a recyklácia vyradených zariadení prispieva k ochrane prírodných zdrojov a zabezpečuje, že recyklácia sa vykonáva spôsobom chrániacim ľudské zdravie a životné prostredie. Informácie o zberných miestach na recykláciu vyradených zariadení vám poskytne miestne zastupiteľstvo, spoločnosť zabezpečujúca odvoz domového odpadu alebo obchod, v ktorom ste si výrobok zakúpili.

**Odstranjevanje odslužene opreme uporabnikov v zasebnih gospodinjstvih v Evropski uniji**

Ta znak na izdelku ali njegovi embalaži pomeni, da izdelka ne smete odvreči med gospodinjске odpadke. Nasprotno, odsluženo opremo morate predati na zbirališče, pooblaščeno za recikliranje odslužene električne in elektronske opreme. Ločeno zbiranje in recikliranje odslužene opreme prispeva k ohranjanju naravnih virov in zagotavlja recikliranje te opreme na zdravju in okolju neškodljiv način. Za podrobnejše informacije o tem, kam lahko odpeljete odsluženo opremo na recikliranje, se obrnite na pristojni organ, komunalno službo ali trgovino, kjer ste izdelek kupili.

**Eliminación de residuos de equipos eléctricos y electrónicos por parte de usuarios particulares en la Unión Europea**

Este símbolo en el producto o en su envase indica que no debe eliminarse junto con los desperdicios generales de la casa. Es responsabilidad del usuario eliminar los residuos de este tipo depositándolos en un "punto limpio" para el reciclado de residuos eléctricos y electrónicos. La recogida y el reciclado selectivos de los residuos de aparatos eléctricos en el momento de su eliminación contribuirá a conservar los recursos naturales y a garantizar el reciclado de estos residuos de forma que se proteja el medio ambiente y la salud. Para obtener más información sobre los puntos de recogida de residuos eléctricos y electrónicos para reciclado, póngase en contacto con su ayuntamiento, con el servicio de eliminación de residuos domésticos o con el establecimiento en el que adquirió el producto.

**Bortskaffande av avfallsprodukter från användare i privathushåll inom Europeiska Unionen**

Om den här symbolen visas på produkten eller förpackningen betyder det att produkten inte får slängas på samma ställe som hushållssopor. I stället är det ditt ansvar att bortskaffa avfallet genom att överlämna det till ett uppsamlingsställe avsett för återvinning av avfall från elektriska och elektroniska produkter. Separat insamling och återvinning av avfallet hjälper till att spara på våra naturresurser och gör att avfallet återvinns på ett sätt som skyddar människors hälsa och miljön. Kontakta ditt lokala kommunkontor, din närmsta återvinningsstation för hushållsavfall eller affären där du köpte produkten för att få mer information om var du kan lämna ditt avfall för återvinning.

Index

Numerics

- 10/100Base-TX ports
 - location on switch ... 1-4
- 1000Base-BX ... B-3
 - fiber-optic cable specifications ... B-3
- 1000Base-LH ... B-3
 - fiber-optic cable specifications ... B-3
- 1000Base-T
 - 1000Base-T
 - fiber-optic cable specifications ... B-3
- 2-post telco rack
 - mounting a 6600 switch ... 2-22
 - mounting brackets ... 2-1
 - rack mount kit ... 2-11
- 4-post rack
 - HP 10000 Series cabinet ... 2-16
 - mounting a 6600 switch ... 2-11–2-12
 - mounting brackets ... 2-2
 - port-side mounting ... 2-13
 - power-side mounting ... 2-13
 - rack mount kits ... 2-2, 2-11

A

- AC power connector
 - location on back of switch ... 1-12
- Act LED ... 1-8, 1-10
- air plenum
 - not required in port-side mounting ... 2-14, 2-19
 - required in power-side mounting ... 2-14, 2-20
 - two sizes ... 2-2, 2-21
- auto MDI/MDI-X operation ... B-7, B-9
 - HP Auto-MDIX feature ... B-6

B

- back of switch
 - description ... 1-12
 - power connector ... 1-12
- basic switch configuration
 - IP address ... 3-3
 - manager password ... 3-3
 - subnet mask ... 3-3
 - switch setup screen ... 3-2

- basic troubleshooting tips ... 5-1
- Bootp
 - automatic switch configuration ... 3-2
 - for in-band access ... 3-5
- buttons
 - Clear button ... 1-11
 - port LED view select button ... 1-9
 - Reset button ... 1-11

C

- cables
 - connecting cables to switch ports ... 2-27
 - effects of non-standard cables ... 5-2
 - fiber-optic, specifications ... B-3
 - infrastructure requirements ... 2-5
 - serial, for direct console connection ... 2-30
- cables, twisted-pair
 - category 3, 4, 5 ... B-6
 - connector pin-outs ... B-6
 - cross-over cable pin-out ... B-8
 - HP Auto-MDIX feature ... B-6
 - MDI-X to MDI connections ... B-7, B-9
 - MDI-X to MDI-X connections ... B-8
 - pin-outs ... B-7, B-9
 - straight-through cable pin-out ... B-7, B-9
 - switch-to-computer connection ... B-7, B-9
 - switch-to-switch or hub connection ... B-8
 - wiring rules ... B-6
- Clear button
 - deleting passwords ... 1-11
 - description ... 1-11
 - location on switch ... 1-4, 1-11
 - restoring factory default configuration ... 1-11, 5-11
 - to delete password protection ... 5-3
- command-line interface (CLI)
 - displaying prompt on console ... 2-30
 - for switch management ... 1-14
 - savepower command ... 1-14
 - system fan-pref-airflow-dir command ... 2-9, 5-3

- configuration
 - checking when troubleshooting ... 5-3
 - DHCP/Bootp ... 3-2
 - IP address ... 3-2–3-3
 - manager password ... 3-3
 - minimal configuration through console
 - port ... 3-1
 - restoring factory defaults ... 1-11, 5-11
 - subnet mask ... 3-3
 - switch setup screen ... 3-2
- connecting the switch to a power source ... 2-24
- console
 - checking messages during reset ... 5-9
 - configuring IP address for Telnet access ... 3-1
 - displaying CLI prompt ... 2-30
 - in-band connection ... 3-5
 - out-of-band connection ... 2-28–2-29
 - serial cable connection ... 2-30
 - switch management ... 2-28
 - switch setup screen ... 3-2
 - Telnet access ... 3-6
 - terminal configuration ... 2-29
- console cable
 - shipped with 6600 switch ... 2-2, 2-29
- console port
 - definition ... 1-11
 - location on switch ... 1-4
 - used for minimal switch configuration ... 1-4–1-5, 3-1
- cross-over cable
 - pin-out ... B-8
- D**
 - deleting passwords ... 1-11
 - description
 - 6600 switches ... 1-1
 - back of switch ... 1-12
 - front of switch ... 1-4
 - LEDs ... 1-7
 - desktop switch
 - sample topology ... 2-32
 - DHCP
 - automatic switch configuration ... 3-2
 - for in-band access ... 3-5
 - diagnostic tests ... 5-9
 - checking console messages ... 5-9
 - checking the LEDs ... 5-9
 - end-to-end connectivity ... 5-10
 - testing the switch only ... 5-9
 - testing twisted-pair cabling ... 5-10
 - downloading new switch software ... 5-12
 - dual-personality ports
 - default operation ... 1-6
 - location on switch ... 1-6
 - on 6600 switches ... 1-13
 - shared RJ-45 and SFP operation ... 1-6
- E**
 - electrical specifications, switch ... A-1
 - EMC regulatory statements ... C-8
 - environmental specifications, switch ... A-1
- F**
 - factory default configuration, restoring ... 1-11, 5-11
 - Fan LED on fan tray ... 1-7
 - Fan Status LED ... 1-7
 - fans
 - replacing fan trays ... 4-1
 - reversing air flow direction ... 1-13, 2-8
 - Fault LED ... 1-7
 - blinking ... 1-9
 - during self test ... 2-7
 - error conditions ... 1-7, 5-4
 - location on switch ... 1-4
 - FDx LED ... 1-8, 1-10
 - features
 - console ... 2-28
 - switch ... 1-13
 - fiber-optic cables ... B-3
 - 1000Base-BX ... B-3
 - 1000Base-LH ... B-3
 - 1000Base-T ... B-3
 - flashing LEDs
 - error conditions ... 5-4

- front of switch ... 1-4
 - 10/100Base-TX ports ... 1-4
 - Clear button ... 1-11
 - description ... 1-4
 - dual-personality ports ... 1-6
 - LEDs ... 1-7
 - network ports ... 1-6
 - port LED view select button and LEDs ... 1-9
 - Reset button ... 1-11
- full-duplex fixed configuration
 - effects on network connections ... 5-1
- full-duplex operation of RJ-45 ports ... 1-13

H

- hold-down brackets
 - used in HP 10000 Series rack mounting ... 2-18
- hot swapping
 - fan tray ... 4-1
- HP 10000 Series cabinet
 - hold-down brackets required ... 2-18
 - mounting a 6600 switch ... 2-11, 2-16
 - port-side mounting ... 2-19
 - power-side mounting ... 2-18
- HP Auto-MDIX
 - feature description ... B-6

I

- in-band console access
 - for switch management ... 3-1
 - types of ... 3-5
- included parts ... 2-1
- installation
 - connecting the switch to a power source ... 2-24
 - location considerations ... 2-5
 - network cable requirements ... 2-5
 - overview ... 2-4
 - precautions ... 2-3
 - rack or cabinet mounting ... 2-11
 - site preparation ... 2-5
- IP address
 - configuring ... 3-3
 - required for networked management sessions ... 3-1

L

LEDs

- Act ... 1-8, 1-10
- behavior during self test ... 2-7
- blinking ... 1-9
- descriptions of ... 1-7
- error conditions ... 5-4
- fan status ... 1-7
- fan tray ... 1-7
- fault ... 1-7
- fault display during self test ... 2-7
- fault display for error conditions ... 5-4
- FDx ... 1-8, 1-10
- link ... 1-8
- location on switch ... 1-4
- port ... 1-8
- Port View, selecting the display ... 1-9
- power ... 1-7
- power display during self test ... 2-7
- power supply status ... 1-7
- self test ... 1-8, 2-7
- Spd ... 1-8, 1-10
- temperature ... 1-7
- used for troubleshooting ... 5-9
- Usr ... 1-8
- Usr Mode ... 1-10
- Link LED ... 1-8
- link test ... 5-10
- location, space in front and back of switch ... 2-5

M

- MAC addresses in forwarding table ... 1-13
- MDI-X to MDI network cable ... B-7, B-9
- MDI-X to MDI-X network cable ... B-8
- mini-GBICs
 - See SFP.*
- mode conditioning patch cord ... B-4
- mounting a 6600 switch
 - 2-post telco rack ... 2-3, 2-22
 - 4-post rack ... 2-3, 2-12
 - HP 10000 Series cabinet ... 2-3, 2-16
 - rack precautions ... 2-3

N

- network cables
 - fiber-optic, specifications ... B-3
 - HP Auto-MDIX feature ... B-6
 - required types ... 2-5
 - twisted-pair, connector pin-outs ... B-6
 - twisted-pair, wiring rules ... B-6
- network devices
 - connecting to the switch ... 2-27
- network ports
 - connecting to ... 2-27
 - location on switch ... 1-6
 - types of ... 1-6
- non-standard network cables, effects ... 5-2

O

- out-of-band
 - console connection required to configure IP address ... 2-30, 3-1
 - direct connection through console port ... 2-28–2-29
 - for switch management ... 3-1
 - networked connection through management port ... 1-5–1-6, 3-5
 - Telnet session for switch management ... 3-6
 - web browser session ... 3-6

P

- parts, included with the switch ... 2-1
- password
 - configuration ... 3-3
 - deleting with the Clear button ... 1-11, 5-3
 - if you lose a password ... 5-3
- physical specifications, switch ... A-1
- Ping test ... 5-10
- pin-outs
 - twisted-pair cables ... B-6
- port configuration
 - checking during troubleshooting ... 5-3
- Port LED View
 - indicator LEDs ... 1-9
 - select button ... 1-9
 - selecting the display ... 1-9

- port LEDs
 - description ... 1-8
 - link ... 1-8
 - normal operation ... 2-7
- ports
 - 10/100Base-TX, location on switch ... 1-4–1-6
 - connecting cables ... 2-27
 - console ... 2-28
 - HP Auto-MDIX feature ... B-6
 - network connections ... 2-27
- port-side mounting
 - 4-post rack ... 2-13
 - in HP 10000 Series cabinet ... 2-19
 - no air plenum required ... 2-14, 2-19
 - reversing air flow direction ... 2-8
 - switch ports face cold aisle ... 2-13, 2-19
- power connector ... 1-12
- power cords ... 2-2
 - routing through air plenum ... 2-15, 2-21
 - securing with velcro strap ... 2-23
- Power LED ... 1-7
 - during self test ... 2-7
 - error conditions ... 1-7
 - location on switch ... 1-4
- Power Save mode ... 1-14
- power source
 - connecting the switch to ... 2-24
- power supply
 - replacing ... 4-3
- Power Supply LED ... 1-7
- power-side mounting
 - 4-post rack ... 2-13
 - air plenum required ... 2-14, 2-20
 - in HP 10000 Series cabinet ... 2-18
 - power supplies face cold aisle ... 2-13, 2-20
- precautions
 - mounting a 6600 switch ... 2-3
 - power requirements ... 2-3
- preparing the installation site ... 2-5
- Proactive Network tools
 - used for diagnostics ... 5-8
- ProCurve Manager
 - SNMP-based network management ... 1-14

R

- rack
 - 2-post telco rack ... 2-3, 2-22
 - 4-post rack ... 2-3, 2-12
 - HP 10000 Series cabinet ... 2-3, 2-16
 - mounting precautions ... 2-3
- ranges
 - voltage ... 1-12, 2-6
- recycle statements ... D-1
- regulatory statements ... C-8
- replacing hardware
 - fans ... 4-1
 - power supply ... 4-3
- Reset button
 - description ... 1-11
 - location on switch ... 1-4, 1-11
 - restoring factory default configuration ... 5-11
- resetting the switch
 - factory default reset ... 5-11
 - location of Reset button ... 1-11
 - troubleshooting procedure ... 5-9
- reversing air flow
 - from default power-to-port direction ... 1-13, 2-8

S

- safety and regulatory statements ... C-1
- safety specifications ... A-3
- selecting the Port LED View display ... 1-9
- self test
 - Fault LED behavior ... 2-7
 - LED behavior ... 2-7
 - Power LED behavior ... 2-7
- Self Test LED ... 1-8
 - behavior during factory default reset ... 5-11
- serial cable
 - for direct console connection ... 2-30
- SFP
 - mini-GBIC transceiver ... 1-13, 2-24
 - supported slots on 6600 switches ... 1-4–1-5, 2-26
 - used in dual-personality ports ... 2-24
- SFP+
 - 10 Gigabit connectivity ... 1-13, 2-24
 - supported slots on 6600 switches ... 1-4–1-5, 2-26
- slots supported for mini-GBICs ... 1-4
- Spanning Tree Protocol ... 1-14

- Spd LED ... 1-8, 1-10
- specifications
 - cabling ... B-1
 - distance ... B-3
 - electrical ... A-1
 - environmental ... A-1
 - physical ... A-1
 - safety ... A-3
- straight-through cable
 - pin-out ... B-7, B-9
- subnet mask
 - configuration ... 3-3
- switch
 - 6600 product descriptions ... 1-1
 - connecting to a power source ... 2-24
 - downloading new software ... 5-12
 - electrical specifications ... A-1
 - environmental specifications ... A-1
 - front panel description ... 1-4
 - included parts ... 2-1
 - installation ... 2-4
 - LED descriptions ... 1-7
 - MAC addresses in forwarding table ... 1-13
 - manager password ... 3-3
 - minimal configuration through console
 - port ... 3-1
 - physical specifications ... A-1
 - plug-and-play networking ... 1-13
 - product features ... 1-13
 - verifying operation after installation ... 2-5
- switch setup screen ... 3-2
 - configuring a subnet mask ... 3-3
 - configuring an IP address ... 3-3
 - field descriptions ... 3-3

T

- technology distance specifications ... B-3
- Telnet session
 - for switch management ... 3-6
- Temperature LED ... 1-7
- terminal configuration ... 2-29
- Test LED
 - during self test ... 2-7

- testing
 - checking console messages ... 5-9
 - checking the LEDs ... 5-9
 - diagnostic tests ... 5-9
 - end-to-end communications ... 5-10
 - link test ... 5-10
 - Ping test ... 5-10
 - switch operation ... 5-9
 - switch-to-device communications ... 5-10
 - twisted-pair cabling ... 5-10
 - topologies
 - effects of improper topology ... 5-2
 - sample network with 6600 switches ... 2-32
 - transceivers
 - connecting cables ... 2-27
 - installation ... 2-25
 - removal ... 2-26
 - SFP (mini-GBIC) and SFP+ supported ... 2-24
 - supported speeds and technologies ... 1-3
 - troubleshooting
 - basic tips ... 5-1
 - checking console messages ... 5-9
 - checking port configuration ... 5-3
 - checking the LEDs ... 5-9
 - common network problems ... 5-1
 - configuring air flow log message ... 2-9, 5-3
 - connecting to fixed full-duplex devices ... 5-1
 - diagnostic tests ... 5-9
 - effects of improper topology ... 5-2
 - effects of non-standard cables ... 5-2
 - incorrect air flow ... 5-3
 - link test ... 5-10
 - lost password ... 5-3
 - Ping test ... 5-10
 - Proactive Network tools ... 5-8
 - restoring factory default configuration ... 5-11
 - switch hardware ... 5-1
 - testing connections to other devices ... 5-10
 - testing end-to-end communications ... 5-10
 - testing the switch ... 5-9
 - testing the twisted-pair cables ... 5-10
 - twisted-pair cable
 - cross-over cable pin-out ... B-8
 - pin-outs ... B-6–B-7, B-9
 - straight-through cable pin-out ... B-7, B-9
 - switch-to-computer connection ... B-7, B-9
 - switch-to-switch or hub connection ... B-8
 - testing ... 5-10
 - twisted-pair ports
 - HP Auto-MDIX feature ... B-6
- ## U
- USB port
 - processing USB command file ... 1-13
 - Usr LEDs ... 1-8
 - Usr Mode LED ... 1-10
- ## V
- VLANs ... 1-14
 - voltage ranges ... 1-12, 2-6
 - VT-100 terminal
 - serial cable connection ... 2-30
- ## W
- web browser interface
 - for switch management ... 1-14, 3-6
 - wiring rules for twisted-pair cables ... B-6

Technology for better business outcomes

To learn more, visit www.hp.com/networking/

© Copyright 2011 Hewlett-Packard Development Company, L.P.

The information contained herein is subject to change without notice. The only warranties for HP products and services are set forth in the express warranty statements accompanying such products and services. Nothing herein should be construed as constituting an additional warranty.

HP will not be liable for technical or editorial errors or omissions contained herein.



August 2011

Manual Part Number
5992-4962

