

MBM Triumph 5551-06 Hydraulic Paper Cutter

Instruction Manual



Provided By

MyBinding.com®
When Image Matters.

EBA 551-06
EBA 551-06 LT



- Sicherheitshinweise • Safety precautions
- Consignes de sécurité • Veiligheidsvoorschriften
- Misura di Sicurezza • Normas de Seguridad
- Säkerhetsföreskrifter • Turvallisuusohjeita • Sikkerhedsforskriftene
- Srodki bezpieczeñstwa • Меры предосторожности

EBA 551-06 • EBA 551-06 LT



- D** Bitte lesen Sie vor Inbetriebnahme der Maschine unbedingt diese Betriebsanleitung und beachten Sie die Sicherheitshinweise. Die Betriebsanleitung muss jederzeit verfügbar sein.
- GB** Please read these operating instructions before putting the machine into operation and observe the safety precautions. The operating instructions must always be available.
- F** Nous vous prions de lire attentivement le mode d'emploi avant d'utiliser la machine, et attirons votre attention sur les consignes de sécurité. Les instructions d'utilisation et les consignes de sécurité doivent toujours être disponibles. Les instructions d'utilisation et les consignes.
- NL** Lees u voor de ingebruik name van het apparaat a.u.b. deze gebruiksaanwijzing goed door en neemt u de veiligheidsinstructies n acht. De gebruiksaanwijzing en de veiligheids-voorschriften moeten altijd binnen handbereik zijn.
- I** Per favore legga questo manuale di istruzione prima di mettere in funzione il distruggidocumenti e osservi le regole di sicurezza. Le istruzioni d'uso devono essere sempre disponibili.
- E** Le recomendamos lea las instrucciones antes de poner en funcionamiento esta máquina y cumpla las normas de seguridad. Las instrucciones de servicio y seguridad deben estar siempre disponibles.
- S** Läs igenom denna bruksanvisning innan ni startar maskinen. Var noga med säkerhetsföreskrifterna. Instruktionsmanualen måste alltid finnas tillgänglig.
- FIN** Lue nämä käyttö-ohjeet läpi ennenkuin käynnistät laitteen !
Noudata turvaohjeita. Käyttöohjeiden on oltava aina saatavilla.
- N** Lees gjennom denne bruksanvisningen før De tar i bruk maskinen
Vær oppmerksom på sikkerhetsforskriftene. Operatørmanualen må alltid være tilgjengelig.
- PL** Proszę uważnie przeczytać instrukcję obsługi przed uruchomieniem urządzenia i stosować się do przepisów bezpieczeñstwa. Instrukcje obsługi muszą być zawsze dostępne.
- RUS** Пожалуйста, прочитайте инструкцию по эксплуатации перед установкой аппарата, соблюдайте технику безопасности. Инструкция по эксплуатации должна находиться в доступном для пользователя месте.
- H** A gép üzembe helyezésé elott figyelmesen olvassa el a kezelési utasitást és tartsa be a biztonsági eloirásokat. Kezelési utasításnak mindig elérhetőnek kell lennie.
- TR** Lütfen makineyi çalıştırmadan önce bu kullanma talimatlarını dikkatli bir şekilde okuyunuz ve belirtilen güvenlik önlemlerine uyunuz. Kullanma Talimatları her zaman kullanıma hazır olmalıdır.
- DK** Før installation af maskinen bedes De venligst læse brugervejledningen brugervejledningen og være opmærksom på sikkerhedsanvisningerne. Brugervejledningen skal altid være tilgængelig.
- CZ** Prosím přečtete si instrukce k obsluze a dodržujte bezpečnostní upozornění. Návod k obsluze musí být vždy dostupný.
- P** Por favor leiam o manual de instruções antes de colocar a máquina em operação e vejam as precauções de segurança. As instruções de operação deverão estar sempre disponíveis.
- GR** ΠΑΡΑΚΑΛΩ ΔΙΑΒΑΣΤΕ ΤΙΣ ΟΔΗΓΙΕΣ ΧΡΗΣΕΩΣ ΚΑΙ ΤΙΣ ΠΡΟΦΥΛΑΞΕΙΣ ΑΣΦΑΛΕΙΑΣ ΠΡΙΝ ΒΑΛΕΤΕ ΤΟ ΜΗΧΑΝΗΜΑ ΣΕ ΛΕΙΤΟΥΡΓΙΑ. ΟΙ ΟΔΗΓΙΕΣ ΧΡΗΣΗΣ ΠΡΕΠΕΙ ΝΑ ΕΙΝΑΙ ΠΑΝΤΑ ΔΙΑΘΕΣΙΜΕΣ.
- CHI** 使用機器前，請閱讀此操作指引，並留意安全守則
操作手冊必須是經常可用的。
- UAE** والامان والوقاية تعليمات ملاحظة نرجوا كما الماكينة بتشغيل البدء قبل التشغيل تعليمات قراءة نرجوا لا بد من وجود تعليمات التشغيل دائما



- D** Keine Bedienung durch Kinder!
GB Children must not operate the machine!
F Pas d'utilisation par un enfant!
NL Geen bediening door kinderen!
I Non lasciare utilizzare il tagliacarte a bambini!
E ¡No dejar que la utilicen los niños!
S Installera maskinen utom räckhåll för barn!
FIN Asentakaa laite lasten ulottumattomiin!
N Installer maskinen utenfor rekkevidde for barn!
PL Dzieciom nie wolno obsługiwać urządzenia!
RUS Не допускайте детей к пользованию аппаратом!
H Gyerekek a gépet nem kezelhetik!
TR Makinayı Çocuklar Kullanmamalıdır!
DK Må kun betjenes af voksne!
CZ Stroj nesmí být obsluhován dětmi!
P As crianças não devem trabalhar com a máquina!
GR ΑΠΑΓΟΡΕΥΕΤΑΙ Η ΧΡΗΣΗ ΑΠΟ ΠΑΙΔΙΑ!
CHI 勿让儿童使用机器!
UAE يجب علي الأطفال عدم تشغيل الماكينة.



- D** Nicht unter das Messer fassen!
GB Do not reach beneath the blade!
F Ne pas passer les mains sous la lame!
NL Niet met de handen onder het mes komen!
I Non toccare la lama nella parte inferiore!
E ¡No tocar debajo de la cuchilla!
S Sträck inte in handen under kniven!
FIN Älä laita kättäsi terän alle!
N Plasser aldri hender ol. under kniven!
PL Nie wkładac rak pod noże!
RUS Избегайте попадания рук под лезвие!
H Ne nyúljon a kés alá!
TR Elinizi bıçağın altına sokmayınız!
DK Stik ikke hænderne ind under knivbladet!
CZ Nesahejte pod ostrí nože!
P Não tocar na parte inferior da faca!
GR ΜΗΝ ΑΓΓΙΖΕΤΕ ΤΟ ΚΑΤΩ ΜΕΡΟΣ ΤΗΣ ΛΕΠΙΔΑΣ!
CHI 请勿接触刀具的下方。
UAE لا تصل تحت السكين



- D** Messer nie lose liegen lassen!
Messer nur mit Messerwechsellvorrichtung oder im Messertransportkasten befördern!
(Siehe Seite 26 und 28).
⚠ **Warnung!** Verletzungsgefahr!
- GB** Never leave the blade unattended!
Do not extract or transport the blade without protection!
(See page 26 and 28).
⚠ **Danger!** Risk of injury!
- F** Ne jamais laisser la lame sans protections!
Elle ne doit être démontée qu'à l'aide du dispositif de changement de lame (cf. page 26 et 28), ou transportée dans son étui en bois!
⚠ **Danger!** Risques de coupures!
- NL** Laat nooit de messen alleen achter.
Transporteer de messen niet zonder de houten bescherming (zie pagina 26 en 28).
⚠ **Waarschuwing!** Opgelet voor ongevallen!
Non lasciare mai la lama incustodita. Non rimuovere o trasportare la lama senza protezione. (Vedi pagina 26 e 28).
⚠ **Attenzione!** Rischio di infortunio!
- E** ¡No quitar la cuchilla sin prestar atención. No desmontar no transportar la cuchilla sin protección! (vérase pág. 26 y 28).
⚠ ¡**Advertencia!** ¡Peligro de hacerse daño!
- S** Lämna aldrig maskinen obemannad. Ta inte ur eller transportera kniven utan skydd. (se sid 26 och 28).
⚠ **Skaderisk!**
- FIN** Käsittele terää aina varoen. Älä siirrä tai kuljeta terää ilman suojaa! (katso sivu 26 ja 28).
⚠ **Loukkaantumisen vaara!**
- N** La aldri kniven ligge ubeskyttet. Ta aldri ut kniven eller transporter den uten beskyttelse (Se side 26 og 28).
⚠ **FARE!** Muligheter for skade!
- PL** Nigdy nie pozostawiac noży bez nadzoru.
Nie wyciągac lub transportowac noży bez osłon!
(zobacz strona 26 i 28).
⚠ **Ryzyko skaleczenia sie!**
- RUS** Не оставляйте открытое лезвие без присмотра! Не пытайтесь извлечь или транспортировать лезвие без специальных мер предосторожности!
(См. страницы 26 и 28).
⚠ Соблюдайте выше перечисленные правила для избежания травм!
- H** Soha ne hagyja a kést őrizetlenül! Ne vegye ki vagy ne szállítsa a kést védőtok nélkül!
(Lásd 26. és 28. oldal).
⚠ **Veszély!** Sérülésveszély!
- TR** Bıçağı hiçbir zaman gözetimsiz bırakmayınız!
Bıçağı muhafazasız olarak yerinden çıkartmayınız veya taşımayınız! (Sayfa 26 ve 28'e bakınız).
⚠ **Dikkat!** Yaralanma riski!



DK Knivbladet må aldrig efterlades uden opsyn. Forsøg ikke at afmontere eller transportere knivbladet uden beskyttelse! (Se side 26 og 28).

⚠ **FARE!** Risiko for legemlig beskadigelse.

CZ Nikdy nenechávejte nůž bez krytu. Nikdy nevyjímejte nebo neprepravujte nůž bez ochranného krytu (viz. strany 26 a 28).

⚠ **Nebezpečí!** Riskujete zranení.

P Deixar a faca sempre em local seguro! Não retirar ou transportar a faca sem protecção! (Ver pág. 26 e 28).

⚠ **Perigo!** Risco de dano!

GR ΜΗΝ ΑΦΗΝΕΤΕ ΤΗΝ ΛΕΠΙΔΑ ΑΝΕΠΙΤΗΡΗΤΗ! ΜΗΝ ΑΛΛΑΖΕΤΕ Ή ΜΕΤΑΦΕΡΕΤΕ ΤΗΝ ΛΕΠΙΔΑ ΧΩΡΙΣ ΠΡΟΦΥΛΑΞΗ (Δείτε σχετικά στις σελίδες 26 & 28).

⚠ **ΠΡΟΣΟΧΗ!** ΚΙΝΔΥΝΟΣ ΤΡΑΥΜΑΤΙΣΜΟΥ!

CHI 在没人留意的情况下，请勿离开刀具。

在没有保护的情况下，请勿取出或运送刀具！（参阅第 26 和 28 页）。

⚠ **危险！** 可引致受伤！

UAE لا تترك السكين بدون اهتمام

لا تخرج أو تنقل السكين بدون حماية (أنظر صفحة 26 و 28)

⚠ خطر! التعرض للأذى

- Sicherheitshinweise • Safety precautions •
- Consignes de sécurité • Veiligheidsvoorschriften •
- Misura di Sicurezza • Normas de Seguridad •
- Säkerhetsföreskrifter • Turvallisuusohjeita • Sikkerhetsforskriftene •
- Środki bezpieczeństwa • Меры предосторожности •

EBA 551-06 • EBA 551-06 LT

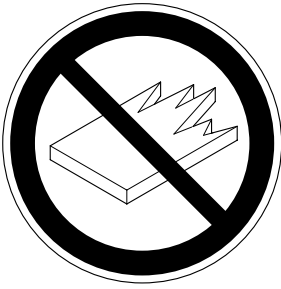

- D** Keine harten und splitternden Materialien schneiden!
GB Do not cut hard materials or materials which may splinter!
F La coupe de matériaux trop durs ou risquant des projections est interdite!
NL Snij geen harde materialen of materiaal dat kan splinteren!
I Utilizzare il tagliacarte esclusivamente per il taglio di risme di carta o materiali analoghi!
E ¡No cortar materiales duros o materiales que puedan astillarse!
S Förstör inte hårt material eller material som kan splittras!
FIN Asentakaa laite lasten ulottumattomiin!
N Ikke kutt hardt metall eller materiale som kan splintre!
PL Nie ciac twardych materiałów lub materiałów, które mogą ulec odprysnięciu!
RUS Данный резак не предназначен для резки твердых материалов или материалов, которые могут расщепляться!
H Ne vágjon kemény vagy olyan anyagot, amely repedhet!
TR Sert veya parçalanabilecek malzemeleri kesmeyiniz!
DK Der må ikke skæres i hårde materialer eller i materialer, der kan splintre!
CZ Neřežte tvrdý materiál, při kterém mohou ustřelovat ostré úlomky!
P Não cortar materiais duros ou materiais que possam lascas!
GR ΜΗΝ ΚΟΒΕΤΕ ΣΚΛΗΡΑ ΥΛΙΚΑ Ή ΥΛΙΚΑ ΠΟΥ ΘΡΥΜΜΑΤΙΖΟΝΤΑΙ!
CHI 请勿切割坚硬或可裂成碎片物料。
UAE لا تقطع الأشياء الصلبة أو الأشياء التي يتطاير منها شظايا!

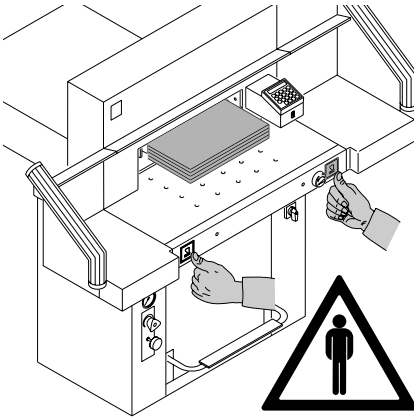

The machine is designed for cutting stacks of paper to a specified size. This machine is constructed for "one-man operation" only!

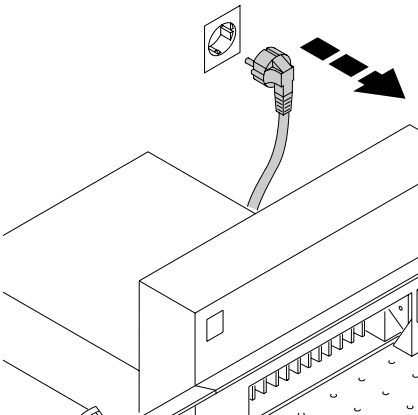

Disconnect from the mains before starting any service work or before removing the panels!

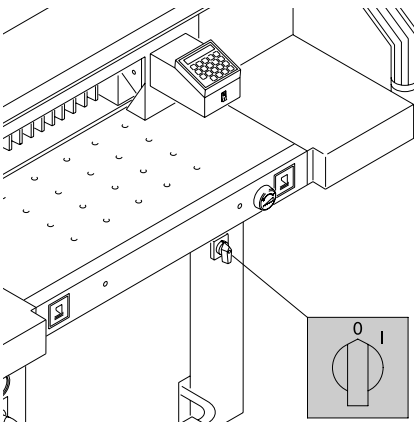

Replacement of blade and cutting stick may be performed only when the main switch is switched off!

EBA 551-06 • EBA 551-06 LT

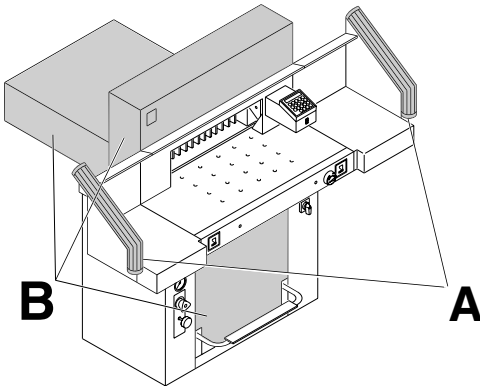

All components which could endanger the operator are covered by a guard (**B**)!

Do not operate the machine without the following safety devices:

- Safety beam guard (**A**)
- Panels, tightly screwed (**B**).

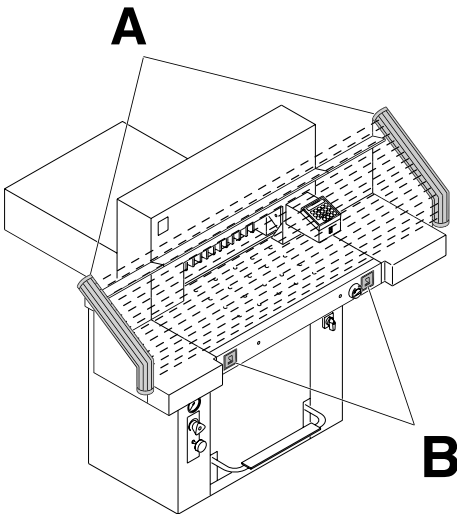

The cutting action, which is dangerous to the operator, is protected by a two-handed control system (**C**) and safety beam guard (**D**).

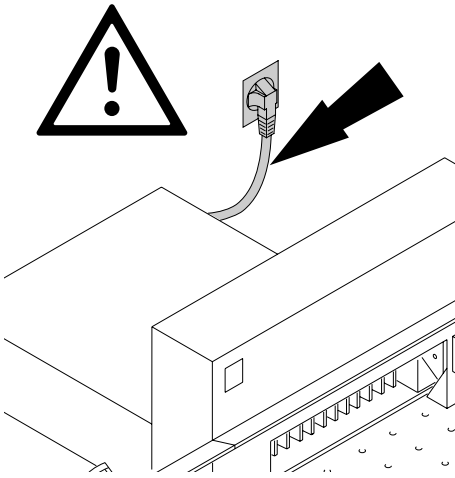

Protect mains cable against heat, oil and sharp edges!

Standard machines are factory-set as follows:

- Voltage 230 V (120 V) 1 phase
- Frequency 50 Hz (60 Hz).

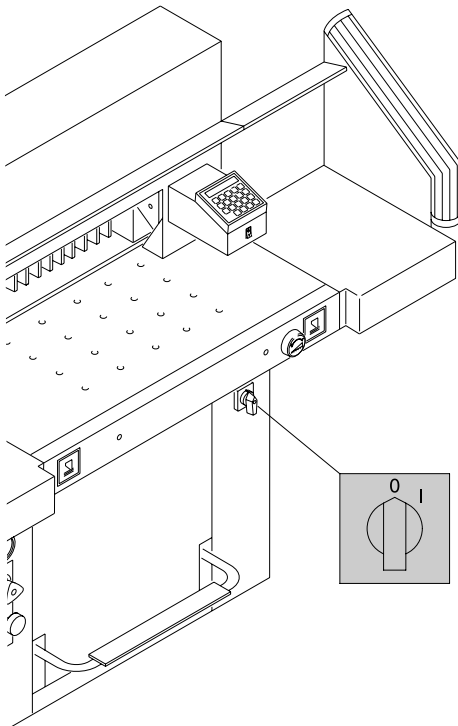

When not in use for a longer period switch off.
(Main switch to "0").

EBA 551-06 • EBA 551-06 LT

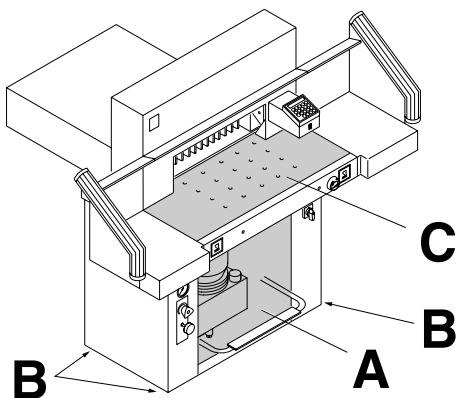

The machine is mobile on castors. Align the machine as follows:

- Remove cover (A).
- Align machine with water level and adjust accordingly.
4 x screws size 19 4 x nuts (B)
- Reference area machine table (C).
- Replace cover (A).

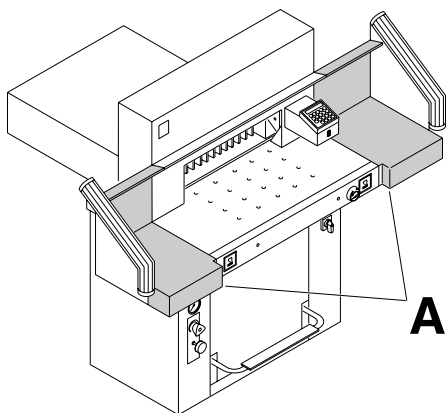

The machine is delivered ready for operation. Side tables (A), left and right are available as an option. Assembly instructions are included.

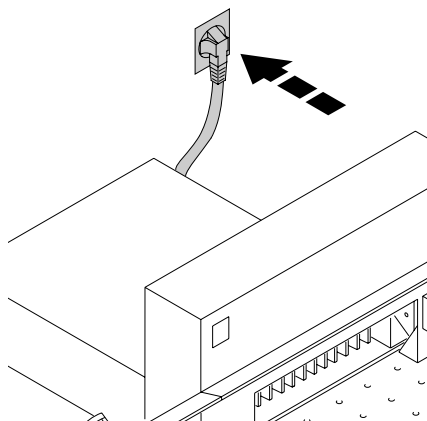

Plug into socket.

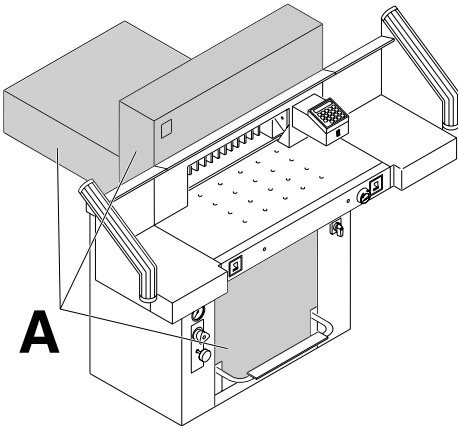

It is forbidden to operate the machine if the operating and safety instructions have not been understood. Please check the safety devices are functioning and complete before use.

- All covers have to be mounted (A).

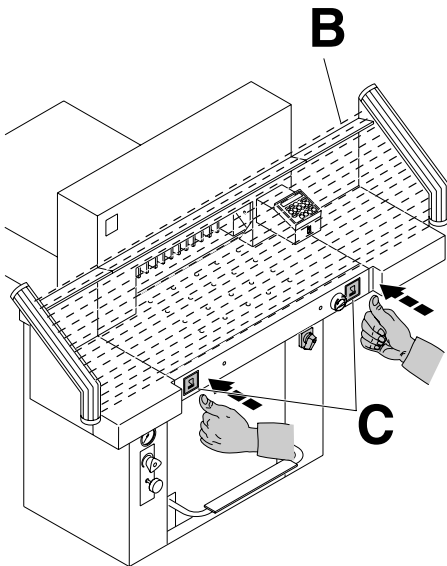

- The release for cutting is allowed only if the two-hand safety device is operated at the same time (C).
- The machine stops immediately if anyone reaches into the cutting area (B).

We recommend you keep a record of your test results.

EBA 551-06 • EBA 551-06 LT

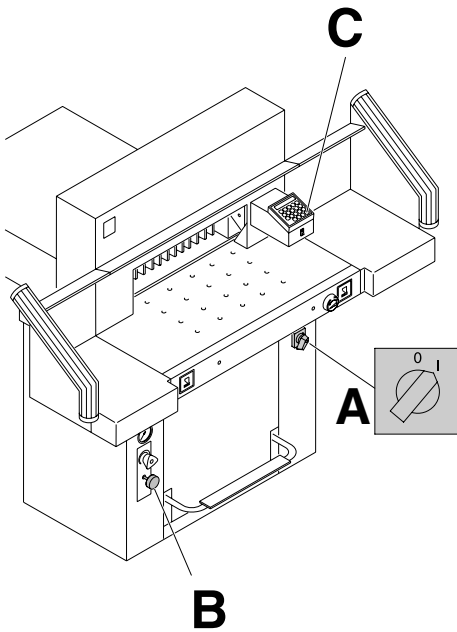

Position the main switch to "I" (A). Blade locking facility (B) must be pulled out. Press  button (C). Machine will automatically go to the start position. The machine is now ready for use.

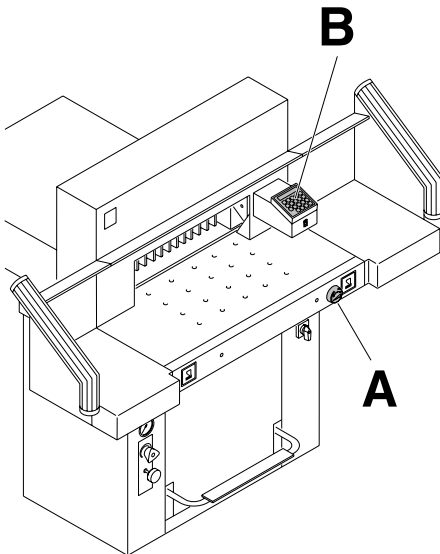

The measurement is set either with the handwheel (A) or by programming (B) the cutting measurements. Measurement is shown on the display in inches or cm (B).

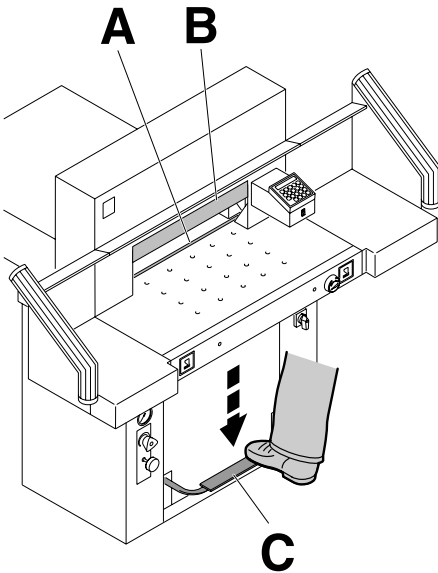

Optical cutting line indicator:

Optical cutting red line (A), indicates the position of the cut. Blade cuts on the front edge of the light beam.

Mechanical cutting line indicator:

The clamp (B) can be used as cutting line indicator for cutting. Pre-clamping can be performed using the foot pedal (C).

Only use the optical cutting line indicator and mechanical cutting line indicator when no exact cut is required.

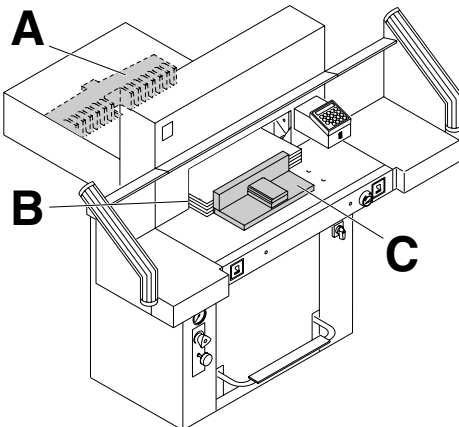

Position the paper on the backgauge (A) and side lays left or right (B). To move paper stacks, please use the paper knock-up block (C) provided.

(Run backgauge to the front for turning the paper stack).

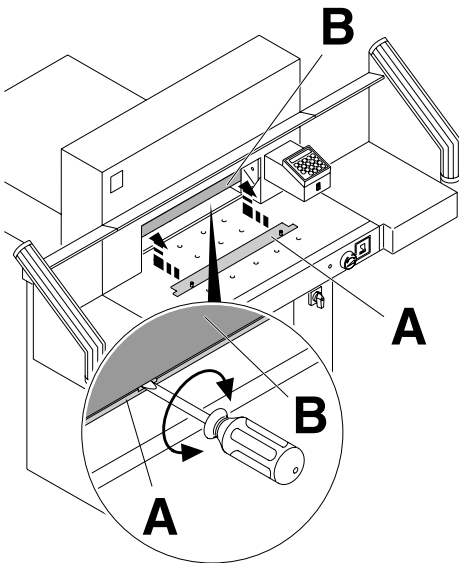

Clamp plate:

A clamp plate (A) is fitted to the machine to prevent pressure marks on sensitive material.

To dismantle:

- Remove the clamp plate (A) by turning the screwdriver (found in tool box) in the space between the clamp and clamp plate.
→ The remaining cut is 32 mm.

To mount:

- The clamp plate (A) is inserted to the top into the clamp (B).
→ The remaining cut is 60 mm.

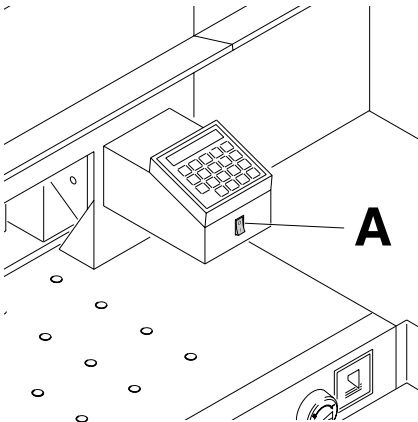

Air table

It is easier to position large stacks of paper when the airtable (A) is switched on.

Setting clamping pressure

If necessary, set clamping pressure with setting wheel (A). If a cutting process has been activated, the oil pressure can be seen on the oil pressure indicator (B).

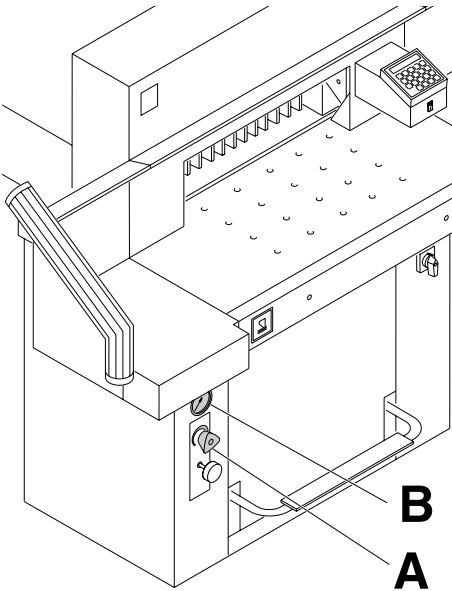

The clamp moves automatically when cutting is activated. The paper can be pressed in advance, with the foot pedal (A). Cutting is activated by pressing both buttons (B) on the front table.

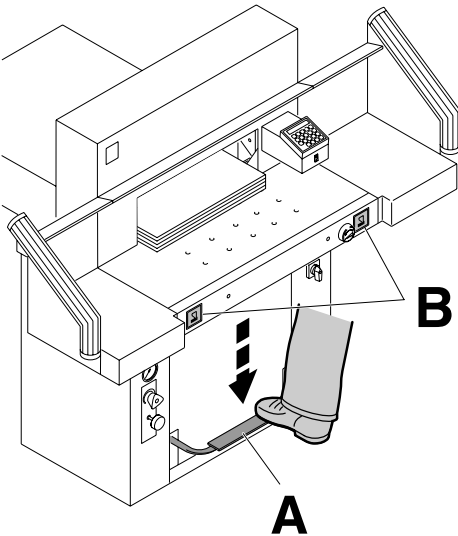

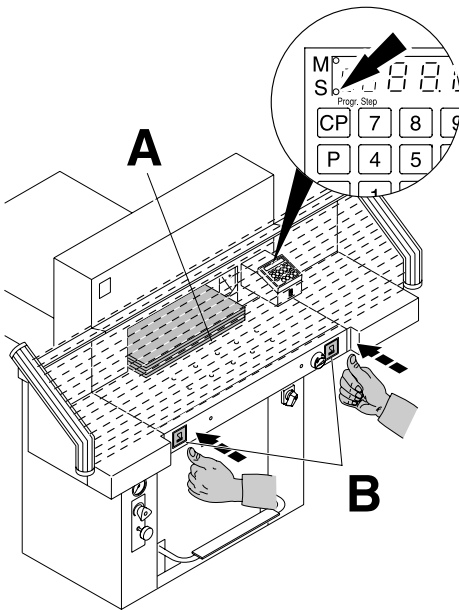

Cutting activation

Do not reach into the cutting area when the blade is in motion. A cut can only be activated when the specified size is approached. The LED "S" on the display must be deleted.

- Release the photo-electric beam guard (A).
- Press both buttons of the safety two-handed control system (B) simultaneously and keep them pressed until the paper is completely cut.

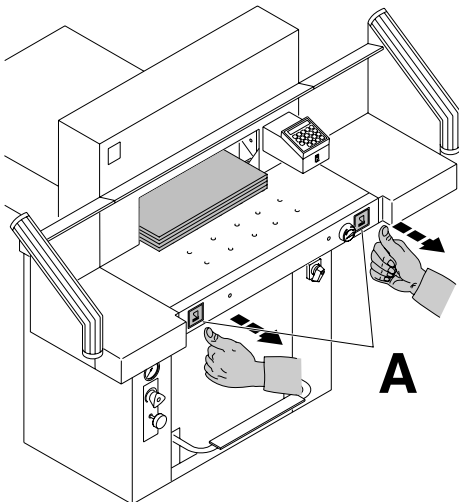

Cutting stop or interruption:

Release both buttons of the two-hand control (A).

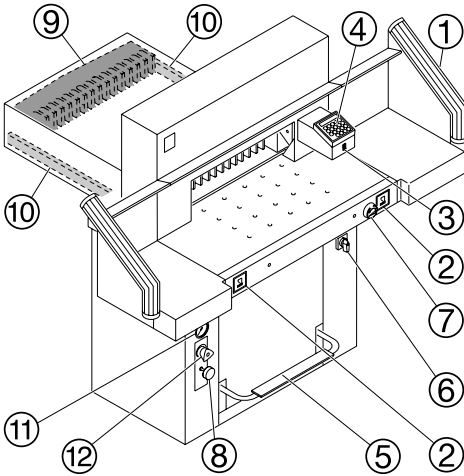

Operating elements

- ① - Safety beam guard
- ② - Safety two-handed control system
Pre-clamping and cutting
- ③ - Air table On-Off
- ④ - Backgauge control (EP)
- ⑤ - Foot pedal with clamp
- ⑥ - Main switch
- ⑦ - Hand-wheel for backgauge setting
- ⑧ - Blade locking
- ⑨ - Backgauge
- ⑩ - Side lay left and right
- ⑪ - Clamp pressure
- ⑫ - Clamp pressure adjustment
- ⑬ - Display cutting size (cm or inch)
- ⑭ - Select program step up
- ⑮ - Select program step down
- ⑯ - Stop and delete input
- ⑰ - Start
- ⑱ - Memory multiple cut
- ⑲ - Keypad
- ⑳ - Changeover cm - inch
- ㉑ - Clear program
- ㉒ - Select program
- ㉓ - Enter
- ㉔ - Program number
- ㉕ - Program step
- ㉖ - Specified dimensions
- ㉗ - Display multiple cut

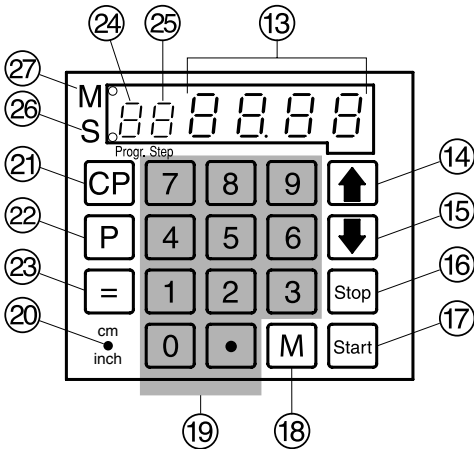

EBA 551-06 • EBA 551-06 LT

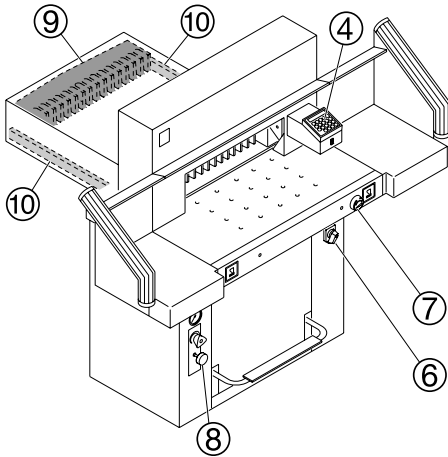

Start machine

- Main switch ⑥ to position "I", Pull out blade locking key ⑧.
- Press **Start** button ⑰ → backgauge ⑨ moves to the rear and searches for the reference position, wait until a measurement is shown in the display ④ (57 cm or 22,44 inches).

⚠ Warning!

Before storing or cutting a measurement please check if the correct measurement scale (cm or inch) see above is stored. For information on how to store see picture below left.

Cutting to specified dimensions

- Enter dimension on the numerical key pad ⑲ → LED "S" ⑳ appears. (If a wrong dimension is entered this can be corrected by pressing the **Stop** button).
- Press **Start** button → dimension is approached, → LED "S" disappears. Dimensions below 9 cm can only be approached with the **Start** button pressed and held. (When the **Start** button ⑰ is released, the backgauge ⑨ moves to a measurement of 9 cm → measurement 9 cm appears, keep the **Start** button pressed, backgauge ⑨ moves to e.g. 7 cm).
- Insert paper and move by means of the stacking angle to the backgauge ⑨ and side lay on the left ⑩.
- Release the cut.

Cut according to markings

- Adjust the backgauge with the hand-wheel ⑦ to the back.
- Insert paper and move by means of the stacking angle to the backgauge ⑨ and side lay on the left ⑩.
- Turn the hand-wheel ⑦ to the right until the marking on the paper to be cut is below the cutting line indicator.
- The further the hand-wheel ⑦ is turned to the right, the quicker the backgauge moves. If the hand-wheel is turned to the left the backgauge will return quicker.
- Release the cut.

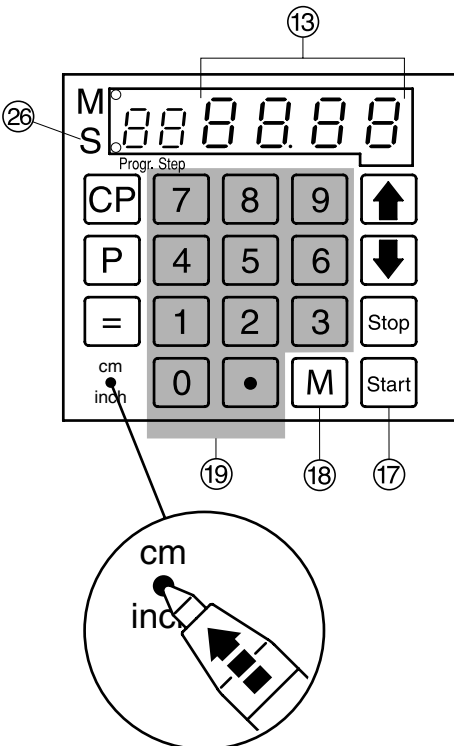

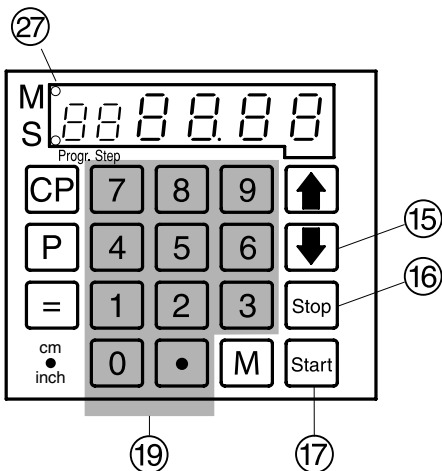

Eject function

If button 15 is pressed instead of button 17, after inserting the measurement, the backgauge will advance forwards to measurement 9 cm/3,54 inch (standard setting of the machine) so that paper can be removed. Finally the backgauge moves to the last setting.

Adjust the eject-dimension

- Press P, press M, Press P press M → E J on display.
- Insert the desired dimension.
- Store dimension.

Multiple cut

- Enter the multiple cut size on the display 19.
- Advance to the measurement with the Start button.
- Push the paper to the backgauge 9.
- Press M button → the red LED "M" 27 light will be on.
- Enter the multiple cut size.
- After each cut the backgauge advances to the next dimension automatically.
- Pressing the Stop button 16 shows the actual size.

Exiting program-mode

- Press M button → LED "M" 27 is cleared on the display.

Cutting activation

⚠ Warning!

- Run backgauge to the front for turning the paper stack.
- Do not interrupt the upward movement of the blade by performing switching procedures.
- Release blade only when LED "S" has gone out.
- Blade must always be at the top and be covered by the clamp. Do not touch the blade.

⚠ Risk of injury!

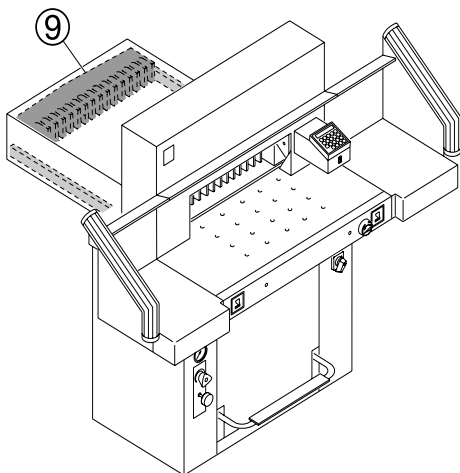

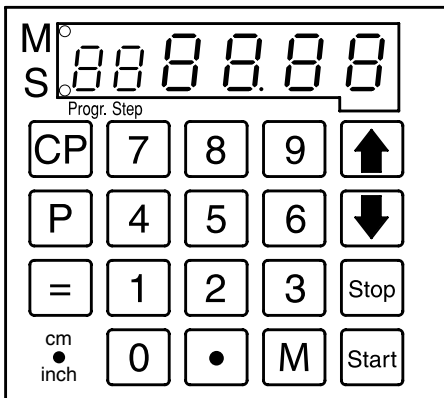

Programming

This control system enables you to store 9 programs with 9 programmable steps. One step represents one measurement. After entering the program numbers you are able to change between several program steps with the button and .

First figure on display = program number.

Second figure = program step. **Dimensions below 9 cm** can only be approached with the button held pressed.

"UL" on the display → the entered dimension is too low.

"OL" on the display → the entered dimension is too high.

The indicated program step can be overwritten at any time. These programs remain stored when the machine is off.

Should you change to another dimension unit all programmed measurements are converted into the new unit (cm or inch).

Entering a program

- Press → PR appears on the display.
 - ... Enter program number 1...9. (First figure on display = program number).
 - Enter dimension, or move the backgauge to the desired measurement with the hand-wheel (A).
 - Store the dimension → next program step appears. If the hand-wheel (A) is used to approach the cutting position press button next program step appears.
 - Enter the next dimension. (Should an ejection be desired before this cut push the button and button simultaneously).
 - Should the entered program be required immediately → press (program is closed). Press again (backgauge moves to the dimension of the first program).
- Or:
- + Escape the program mode.

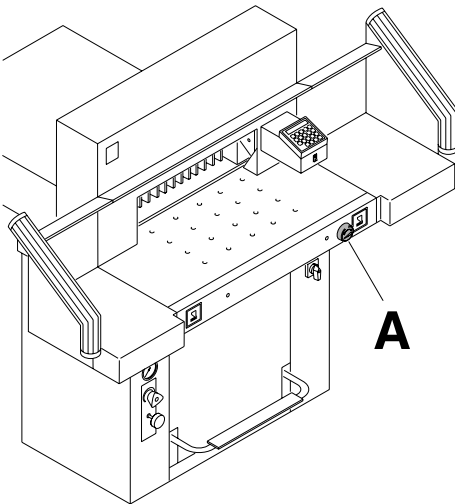

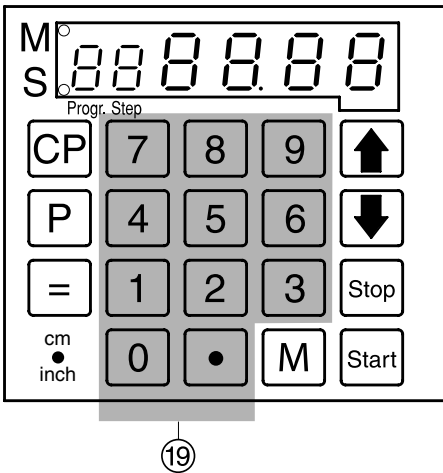

Eject function program

- Set the measurement → push [=] button and ↓ simultaneously. *E J* appears shortly on the display. The backgauge will advance and eject the paper and finally return to the position shown on the display.

Programming of multiple cut dimension

- [P] Press → *PR* appears on the display.
- [1] ... [9] Enter program number 1 ... 9. First figure on display = program number. Second figure = program step. Enter the cut size on the display ⑰.
- [=] Store the dimension.
- [1] ... [9] Enter multiple cut size. → Press [M] button n^1 and multiple cut size appears on the display. Press [M] button again n^2 and second multiple cut size appears etc.
- [=] Store the dimension.
- [P] + [Stop] Escape the program mode. Maximum nine multiple cuts can be entered. Entering the tenth multiple cut will delete the multiple cut and the display will show the actual program step.

Deleting a dimension when programming

Press [Stop] and overwrite the dimension.

Cancel a program

- [P] press → *PR* appears on the display.
- [1] ... [9] Enter program number 1 ... 9.
- Press button [CP] twice. Each program has to be cancelled separately. Only single program steps can be overwritten.

Deleting the last program step

- Enter [0].
- Press [=].
- [P] + [Stop] Escape the program mode.

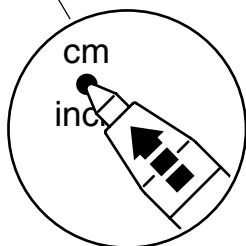
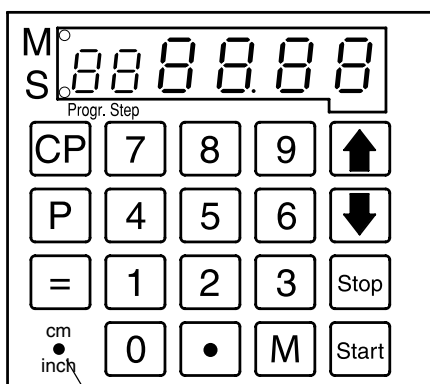

Working with programs

- Press **[P]** → *PR* appears on the display
 - **[1]** ... **[9]** Enter program number 1 ... 9.
- With the button **[↓]** and **[↑]** you are able to change between several program steps. With **[Start]** the backgauge moves to the indicated dimension. With **[Stop]** the backgauge stops.

General

LED "S" blinks → the basic position will appear. LED "S" is off → the actual dimension appears. In the program mode the ejection of paper **[↓]** is not possible. The ejection of paper has to be programmed.

After each cut the backgauge advances to the next dimension automatically.

Escape the program mode

- Press **[P]** → *PR* appears on the display.
- Press **[Stop]** → escape the program mode.

Program buttons **[↑]** and **[↓]** programs

- Button **[↑]** = backgauge position rear
 Button **[↓]** = backgauge position front
- Press **[P]** and simultaneously **[↑]** (*P_U* appears on the display) or Press **[P]** and simultaneously **[↓]** (*P_d* appears on the display)
- Enter the desired dimension (For example: 29,7 cm x 42 cm can be entered for DIN A3)
 - **[=]** Store dimension.

Display in cm or inch

Press **[^{cm}/_{inch}]** → display changes between cm and inch (see picture left). Measurements (in cm or inches) for the rear reference point of the backgauge are shown on the top of page 18.

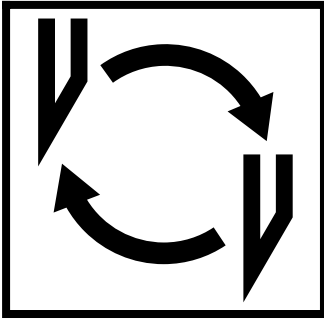

If the cutting quality decreases:

- Check the cutting depth (see page 33).
- Check the cutting stick (see page 27).
- Replace or grind the blade (see page 23 - 32).

The blade cannot be ground if the blade height is less than 82 mm/3,23 inches.

A new blade must be used.

Blades may only be sharpened by a specialist.

⚠ Danger! Risk of injury!

The blade is extremely sharp. Do not extract or transport the blade without protection. Changing the blade may only be performed by trained staff.

EBA 551-06 • EBA 551-06 LT

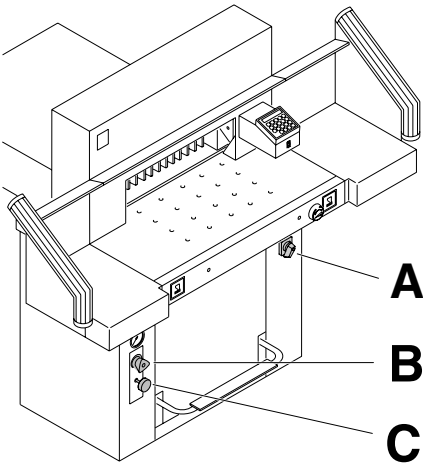

- Set mains switch (A) to position "I" .
- Set clamping oil pressure (B) to min. 50 bar.
- Press in blade locking key (C).
- Activate cutting → blade remains in lowest position.
- Set mains switch to position "0".

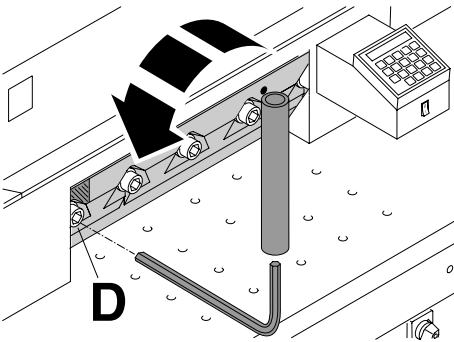

Remove the left screw (D), using the extension.

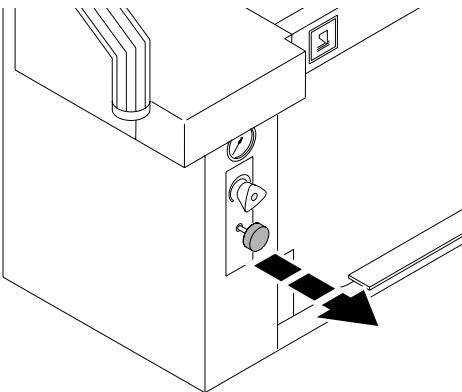

Pull out blade locking key → blade moves to the top.

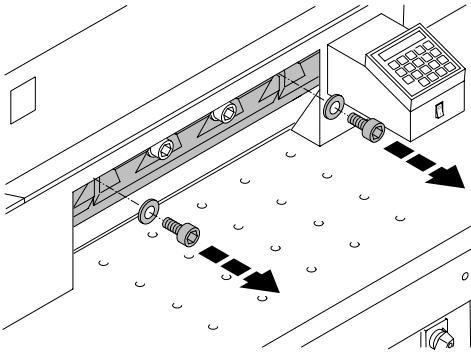

Remove both outer screws.

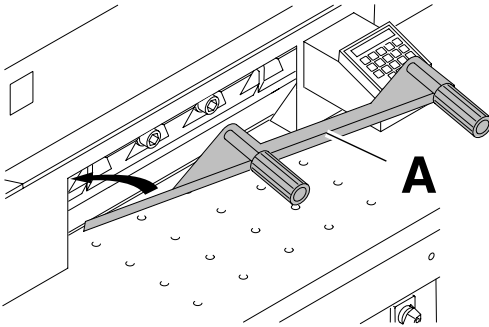

Mount blade changing tool (A).

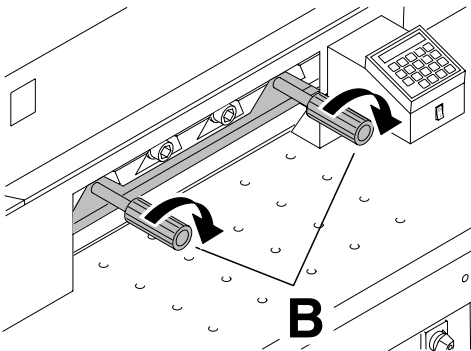

Tighten screws (B).

EBA 551-06 • EBA 551-06 LT

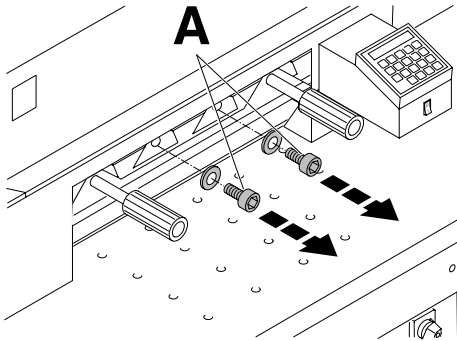

Remove remaining two screws (A).

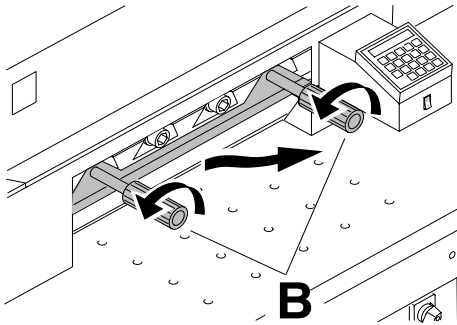

Simultaneously slightly loosen both screws (B) and remove blade with blade changing tool.
Weight of blade approx. 5 kg.

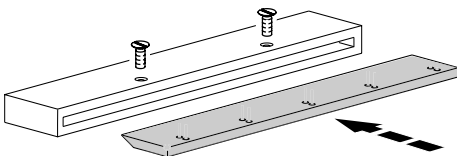

Place the blade into the blade carrier and screw it into place.

- Loosen screws (A) (SW4).
 - Remove cutting stick (B).
 - If needed the cutting stick can be turned or exchanged.
 - Turn screw (C) as far as possible to the right.
 - Slightly tighten screws (A).
- The cutting stick can be used eight times.

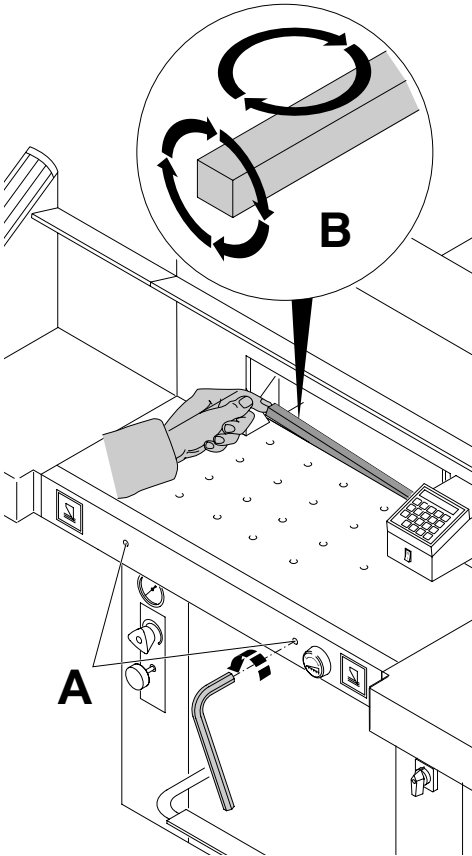

Replacing the cutting stick (not the blade)

- Loosen screws (A) (SW4).
- Remove cutting stick (B).
- Turn the cutting stick (the non-used side must be near to the blade).
- Turn screw (C) as far as possible to the right (Otherwise the first cut will be too deep).
- Slightly tighten screws (A).

⚠ **Danger!** Risk of injury!

Cutting test after replacing the cutting stick (not the blade)

- Insert the paper and release the cut.
- If the last sheet of paper is not cut along the entire length turn the blade adjusting screw (C) 1/6 turn to the left.
- If the last sheet is still not completely cut repeat this process until the last sheet is cut along the entire length.

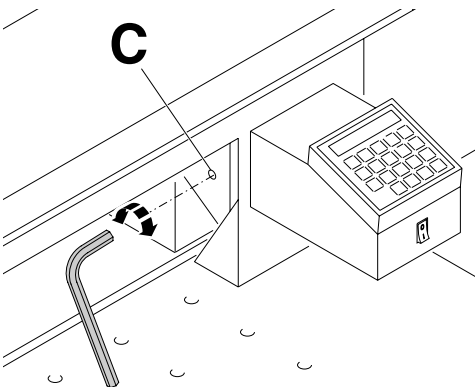

EBA 551-06 • EBA 551-06 LT

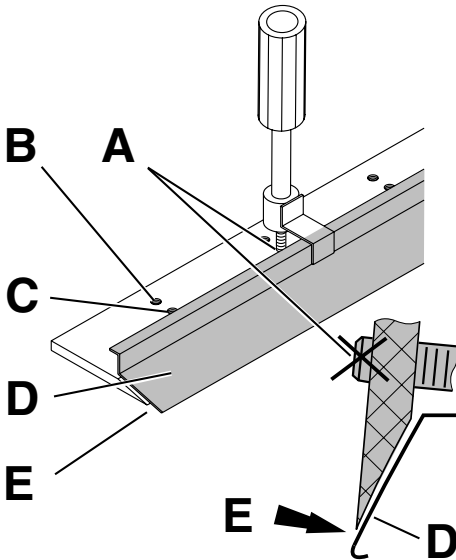

Take the exchange blade carefully out of the blade box and screw it to the blade changing tool (D).

- Check, if when using the upper threads (B), the blade (E) is protected.
- The blade is not protected → Use the lower thread (C) for fixing. The screws (A) may not exceed at the rear side of the blade.

⚠ Danger!
Blade (E) must be protected.

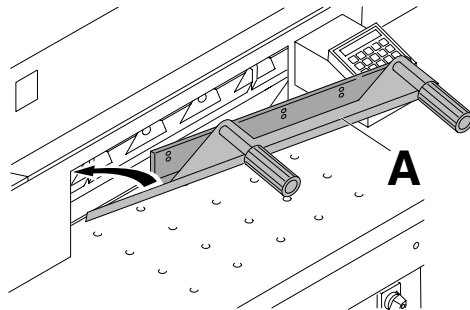

Mount the blade with the blade changing tool (A) ...

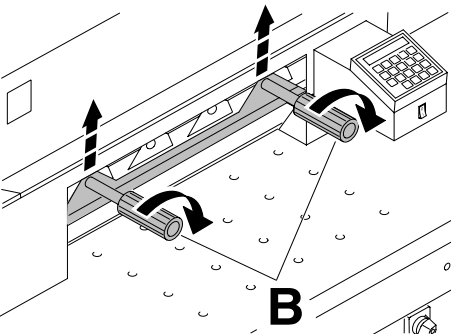

... and tighten with screws (B) in upper position.
Blade must be in the upper position.

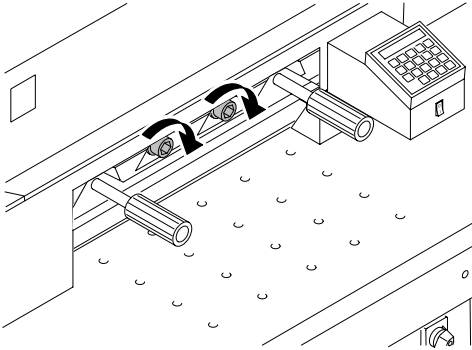

Screw in middle screws and tighten.

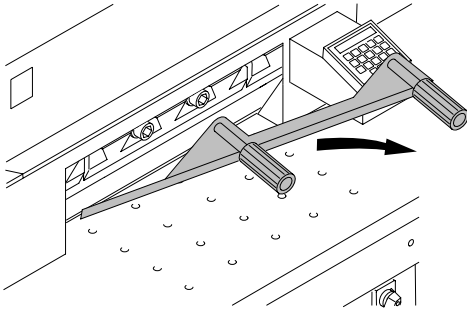

Remove the blade changing tool.

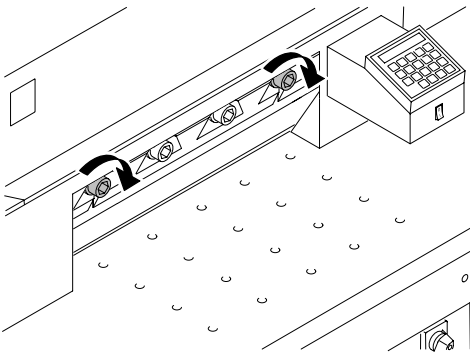

Slightly screw in outer screws.

EBA 551-06 • EBA 551-06 LT

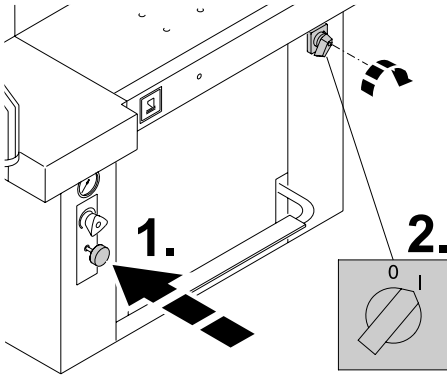

- Press in blade locking key.
- Set main switch to position "I".

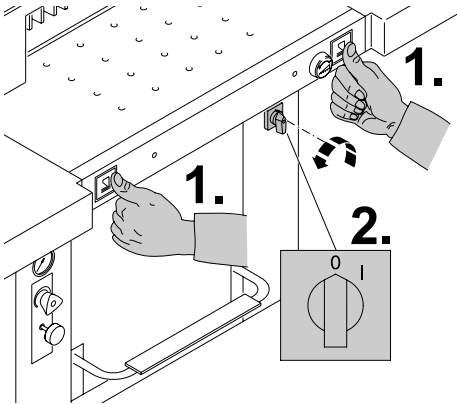

- Activate cutting → blade remains in the lowest position.
- Set main switch to position "0".

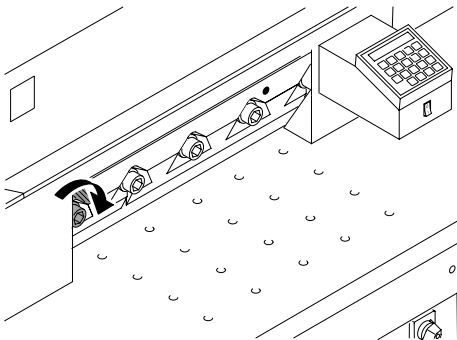

Screw in slightly the left screw.

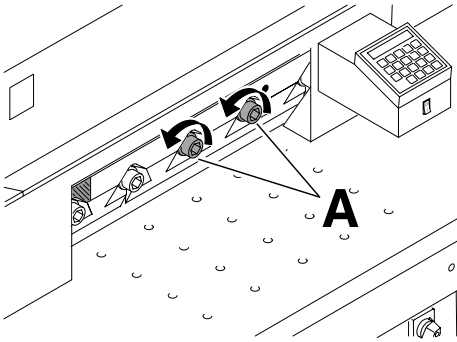

Loosen slightly screws **(A)** so that the blade slides onto the cutting stick.

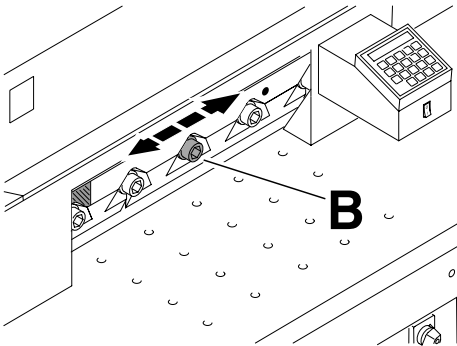

Push the blade and screw **(B)** as far as possible to the left or right and then centralize them. → The blade must rest on the cutting stick.

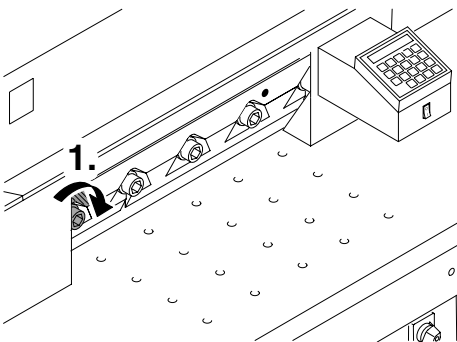

Push in the first screw on the left side and tighten.

EBA 551-06 • EBA 551-06 LT

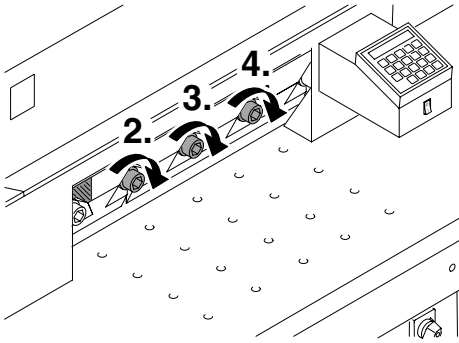

Tighten the remaining 3 screws beginning from the left.

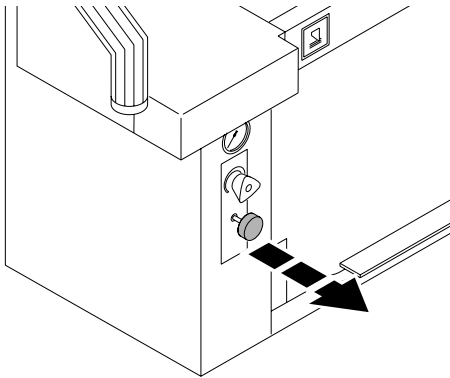

Pull out blade locking key → blade moves to the top.

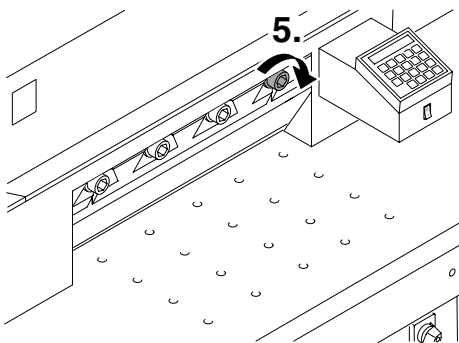

Tighten the screw which is visible at the right.

Turn main switch to position "I".

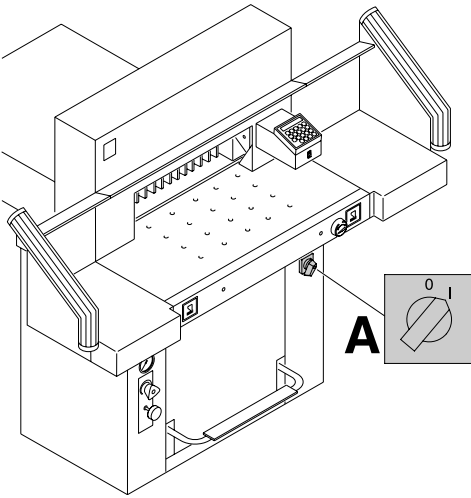

Paper cutting test. If the last sheet or several sheets are not completely cut, gradually turn the knob for blade depth adjustment (A) 1/6 turn to the left until the paper is cut along the entire length. Do not set too low as blade will soon become blunt.

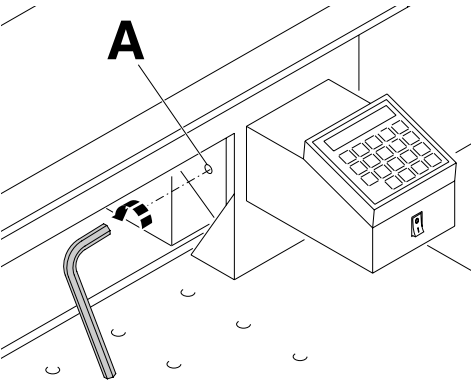

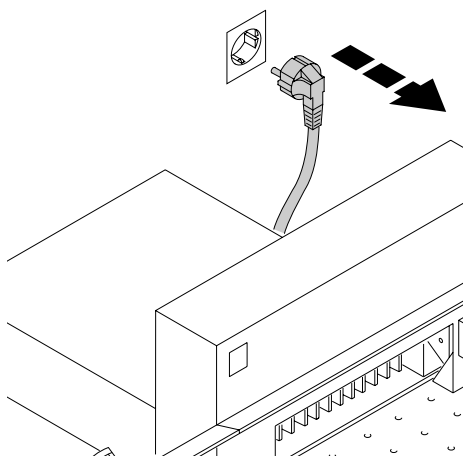

Maintenance work may only be performed by trained staff.

⚠ Danger!
Disconnect the mains before starting any service work or before removing the cover.

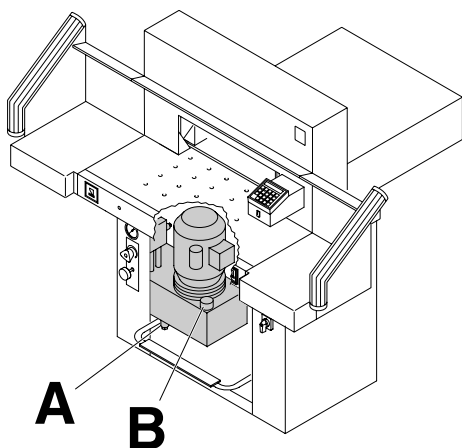

Grease and oil the machine according to the lubrication diagram after 1000 operating hours or once a year. If the machine is subject to excessive load then twice a year.

The hydraulic oil must be changed every 2000 operating hours or every 2 years.

Type of oil:
Aral Vitam DE 46 to DIN 51562.
Volume: approximately 7 litres.

(A) Drain screw
(B) Oil stick

- Check that the hydraulic pump and screws are not leaking. If necessary tighten the retaining nut.
- Check pressure. Maximum pressure is 150 bar.

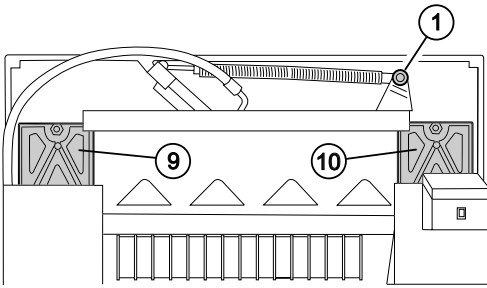

Lubrication schedule

Lubricate (1) to (8).

Type of oil: SAE10 to SAE50 all types.

Grease (9) to (16)

(9+10) Blade guidance

(11-12) Clamp guidance

Type of grease:

Roller bearing grease - all types.

Oil hinges of the foot clamping device at the front area of the machine room.

Type of oil: SAE10 to SAE50 all types.

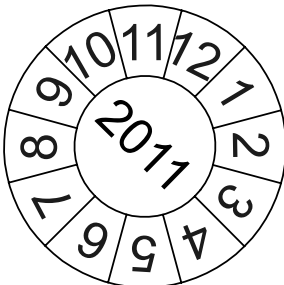
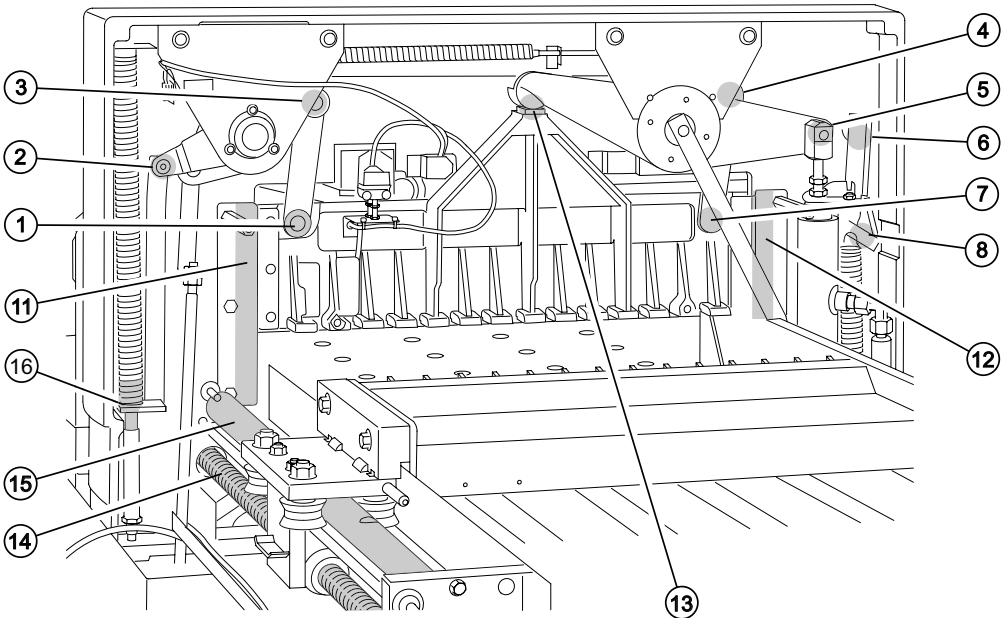

Safety test

The safety regulations are according to the regulations of the country where the cutting machine is operated. The manufacturer recommends a safety check is made every 5 years by an authorised service team.

Machine does not function!



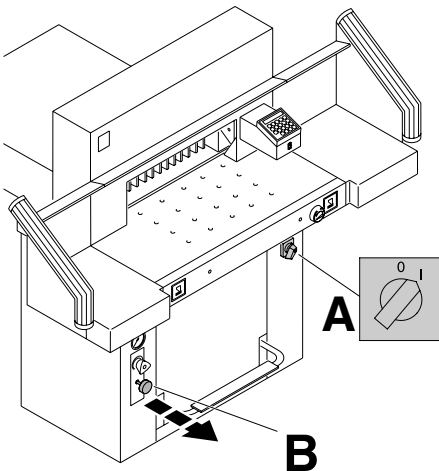
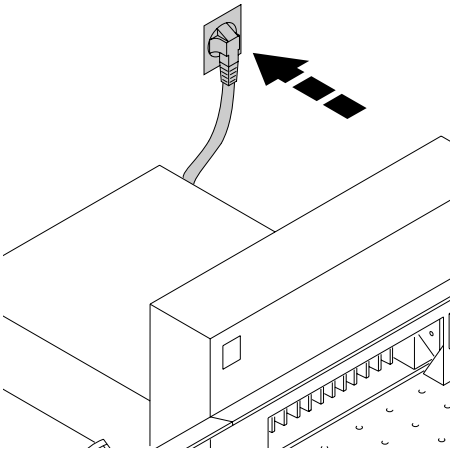

Is the machine plugged in?

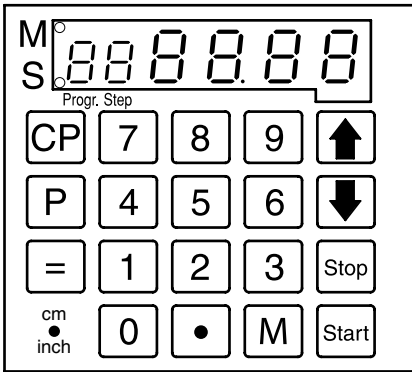

- Main switch to position "I"? (**A**)
- Blade locking facility (**B**) must be pulled out.
- Push in the fuses in the back of the machine F1, F2, F3.
- Check the units fuse and the on-site circuit breaker.



Cut cannot be made.

- Measurement has not been reached correctly. LED "S" does not turn off.
→ Push the  button again.
- Measurement below 9 cm.
→ Hold the  button until the measurement is achieved.

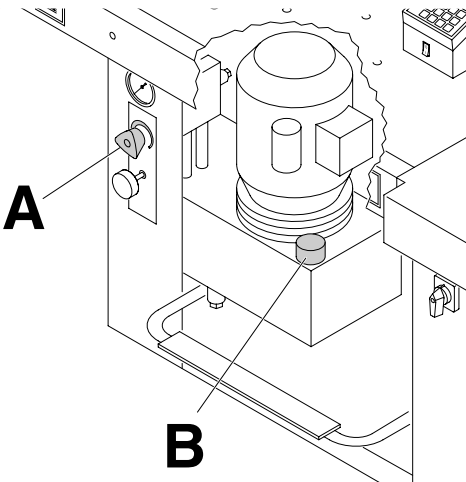

- Oil pressure set too low. → Increase oil pressure at rotary control (A).
- Hydraulic oil shortage. → Check hydraulic oil level (B), if necessary, top up.

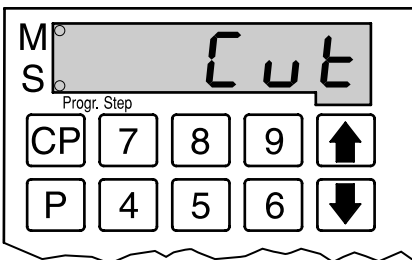

- Backgauge not in the right position, "CUT" on display. → Contact your dealer.

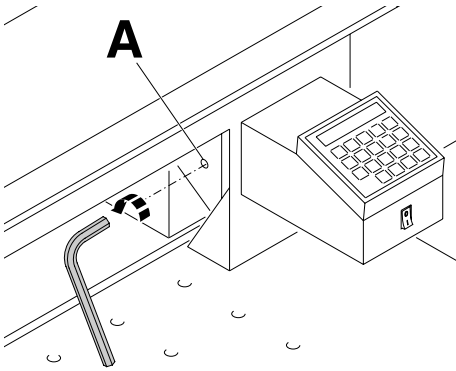

Does not cut through the last sheet.
→ Reset the cutting depth (A) ...

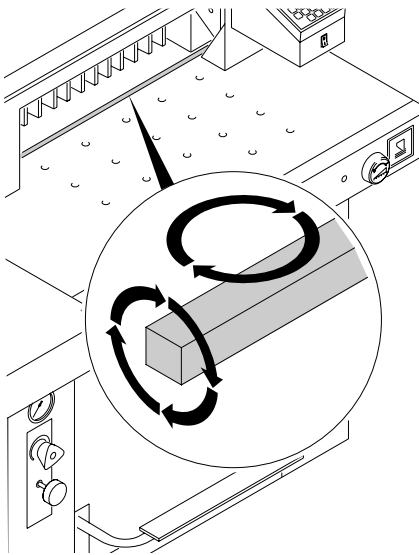

... or turn / replace the cutting stick (B). (See page 27 "Blade and cutting stick replacement").

A reduction in the cutting quality indicates that the blade must be sharpened or a blade change is necessary.

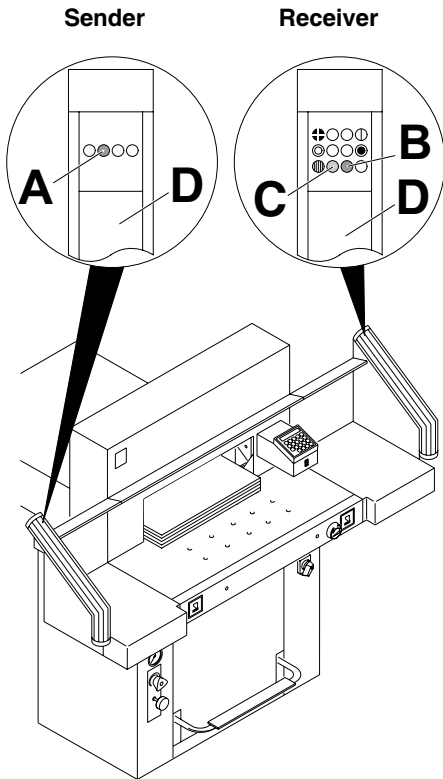

Trouble shooting-light beam

- During normal operation the LED (A) must illuminate orange and LED (B) green.
- Display (C) is permanently on orange when the sender and/or receiver require cleaning. Clean the glass (D) from the sender and receiver.

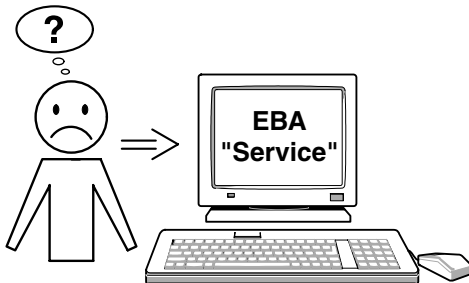

None of the above mentioned methods helped to solve the problem:

Contact Service Team under

- www.eba.de → "Service"
- service@krug-priester.com.

Recommended accessories

HSS - Blade

- 4 244 4 036

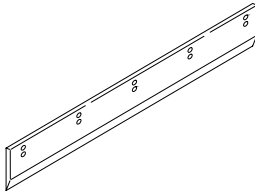

6 Cutting sticks

- 4 244 1 209

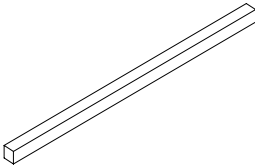

Blade changing tool ¹

- 3 244 0 024

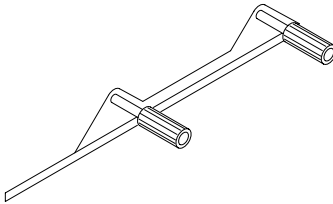

Paper knock-up block ¹

- 9000 521

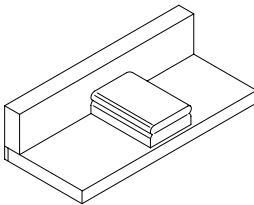

Side tables left and right

- 3 245 7 027

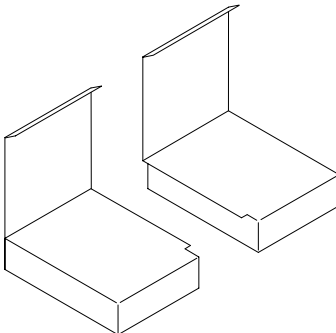

¹ Included in delivery.

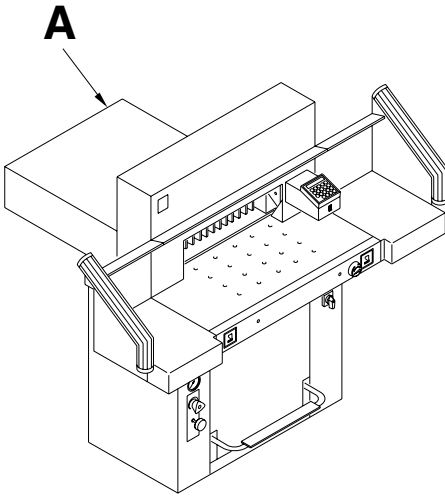

Technical Data

Power supply:	230 V / 50 Hz / 8,5A / 1~ 120 V / 60 Hz / 12A / 1~
Cutting length:	550 mm
Cutting height:	95 mm
Table depth:	570 mm
Sound level EN 13023:	< 70 dB(A)

Minimum space requirement (width x depth x height)

without side tables (mm)	1070 x 1400 x 1370
with side tables (mm)	1630 x 1400 x 1370
Clamping pressure	200 daN bis 1100 daN
Weight without side tables:	305 kg

Capacity of hydraulic oil: 7 l
Aral Vitam DE 46 to DIN 51562.
Used oil must be disposed of at the authorised place.

Ambient operating temperature	10 °C - 60 °C
Air humidity (not condensating)	15 % - 95 %

The exact technical specifications can be found on the technical specifications sticker (A) on the machine. To claim under guarantee, the machine must still carry its original identification label. A wiring diagram is found in the electrical switch box.

Safety beam guard

- Total reaction time: 100 ms
- Resolution 14 mm/minimum distance: 268 mm
- Resolution 20 mm/minimum distance: 308 mm
- Resolution 30 mm/minimum distance: 388 mm

Subject to alteration without notice.



- D EG-KONFORMITÄTSERKLÄRUNG**
- GB EC-declaration of conformity**
- F Déclaration de conformité CE**
- NL EG-verklaring van overeenstemming**
- I Dichiarazione CE di conformità**
- E Declaración CE de conformidad**
- S EG-försäkran om överensstämmelse**

- Hiermit erklären wir, daß die Bauart von

- Herewith we declare that
- Par la présente, nous déclarons que
- Hiermede verklaren wij, dat de in de handel gebrachte machine
- Si dichiara che il modello della
- Por la presente, declaramos que la
- Härmed förklarar vi att den av oss levererade typen av

551-06; 551-06 LT

- folgenden einschlägigen Bestimmungen entspricht

- complies with the following provisions applying to it
- sont conformes aux dispositions pertinentes suivantes
- voldoet aan de eisen van de in het vervolg genoemde bepalingen
- è conforme alle seguenti disposizioni pertinenti
- satisface las disposiciones pertinentes siguientes
- uppfyller följande tillämpliga bestämmelser

98/37/EG; 2006/95/EG; 2004/108/EG

- Angewendete harmonisierte Normen insbesondere

- Applied harmonised standards in particular
- Normes harmonisées utilisées, notamment
- Gebruikte geharmoniseerde normen, in het bijzondere
- Norme armonizzate applicate in particolare
- Normas armonizadas utilizadas particularmente
- Tillämpade standarder, speciellt

**EN 60204-1; EN 1010-1; EN 1010-3; EN 55014-1; EN 55014-2;
EN 61000-3-2; EN 61000-3-3; EN 61496-1; prEN 61496-2;
EN ISO 12100-1; EN ISO 12100-2; EN 294; EN 954-1; EN 13023**

Krug & Priester GmbH u. Co KG
72336 Balingen, Germany

23. 04 . 2007
Datum

W. Priester
Wolfgang Priester
- General Manager -



Aktenvernichter
Document Shredders
Destructeurs de Documents
Papiervernietigers
Distruggidocumenti
Destructoras de Documentos
Dokumentförstörare

Schneidemaschinen
Guillotines
Massicots
Snijmachines
Tagliacarte
Guillotinas
Skärmaskiner

