

At a glance

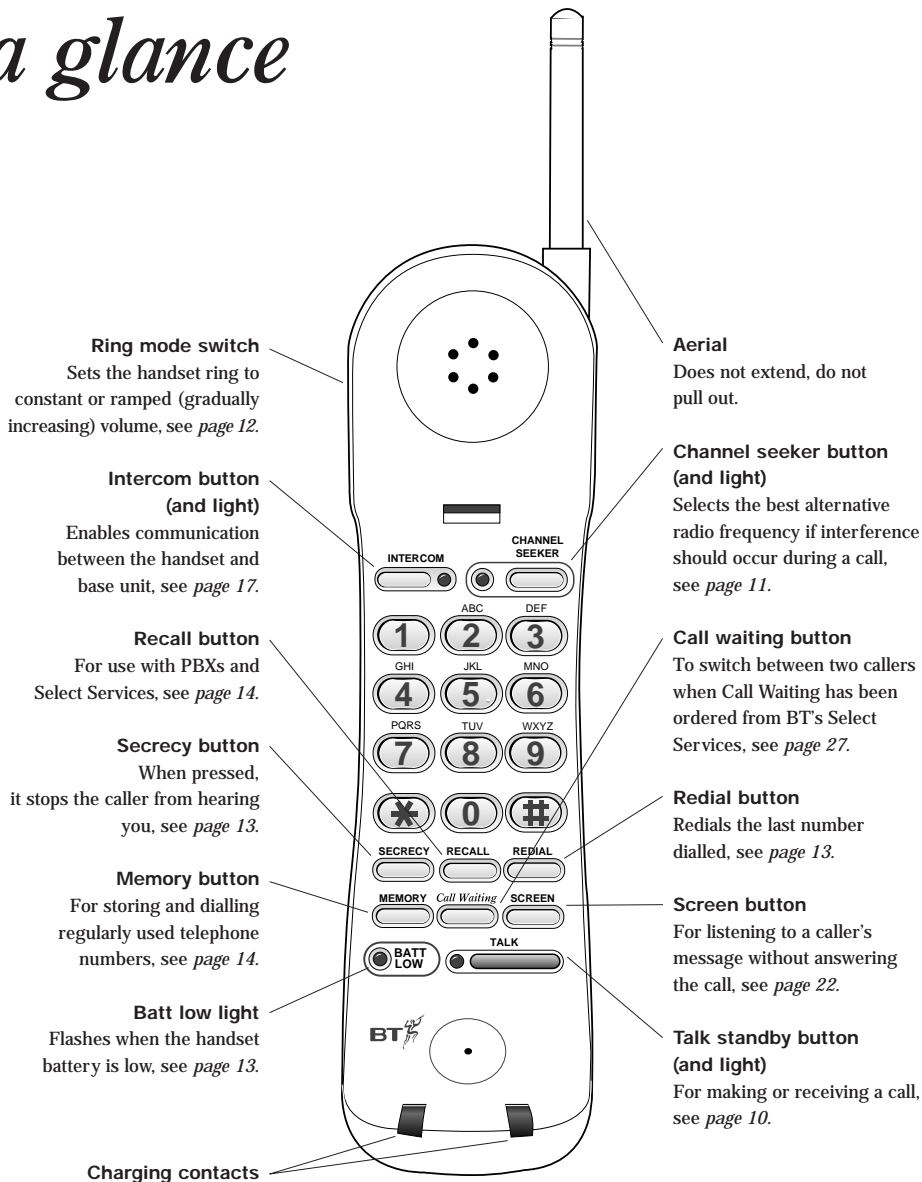

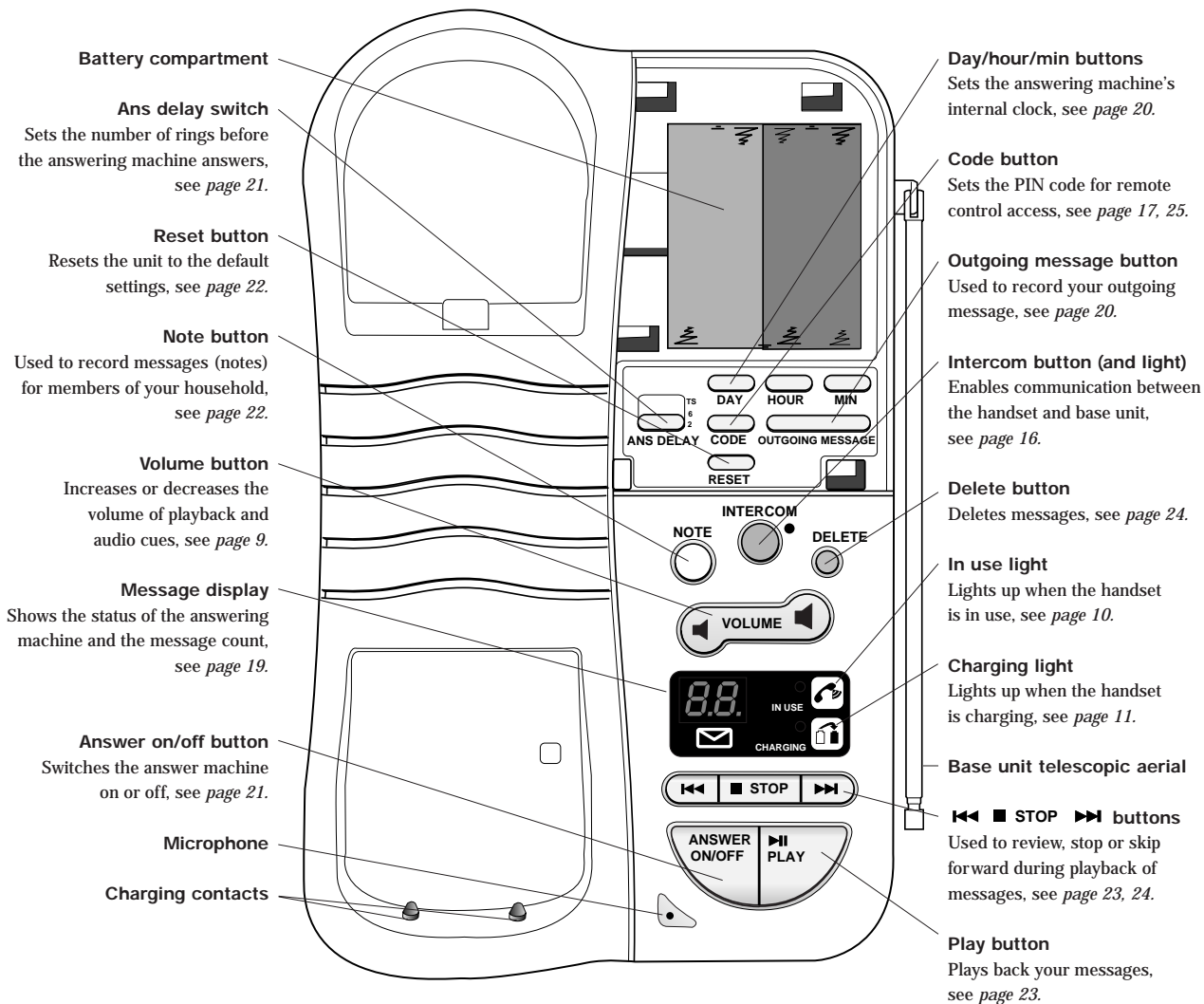

In this guide

<i>At a glance</i>	<i>1</i>
<i>Introduction</i>	<i>4</i>
<i>Setting up</i>	<i>5</i>
<i>Using your Freestyle 1100 Plus</i>	<i>10</i>
<i>Using the answering machine</i>	<i>19</i>
<i>BT's Select Services</i>	<i>27</i>
<i>Help</i>	<i>29</i>
<i>Technical information</i>	<i>33</i>
<i>Maintenance</i>	<i>37</i>
<i>Index</i>	<i>39</i>
<i>Wall mounting</i>	<i>41</i>

Customer Helpline

Should you have problems with your Freestyle 1100 Plus, call the BT Helpline between 9.00am to 5.30pm Monday to Friday on **Lo-call 0345 697146**. Calls will be charged at local rate.

Hints and tips boxes

In this user guide, we've included helpful tips and useful notes. They are shown in a grey box.

Introduction

Your Freestyle 1100 Plus has been designed for ease of use and made to the very high standards set by BT.

We thank you for making the right choice and expect that you will have many years of quality service.

Please read the instructions carefully before use, and retain this user guide for future reference.

For your records:

Date of purchase:

Place of purchase:

Serial number

on the underside of base-unit:

Purchase price:

For warranty purposes, proof of purchase is required, so please keep your receipt.

Emergency Calls

The emergency services can be contacted in the UK by dialling 999. You may also dial 112 which is valid in any country that is a member of the European community. As the Freestyle 1100 Plus is a mains powered cordless telephone there are certain situations where you may not be able to make an emergency call:

- *If there is severe radio interference.*
- *If the handset batteries fail.*
- *If there is a power cut and there are no back-up batteries in the base unit.*

If your Freestyle 1100 Plus is connected to a PBX, you may have to dial an access number before 999 to contact the emergency services.

Some switchboards are not able to dial out during a power failure.

Setting up

Follow these steps in sequence to completely set up your Freestyle 1100 Plus ready for use.

As this product is rechargeable, it is normal that a certain amount of heat will be produced in its day-to-day operation. Whilst this is entirely safe we would advise against placing this product on antique, veneered or wooden surfaces as damage may occur.

Plan where you will put your Freestyle 1100 Plus. It should be within two metres of a power socket and the phone socket.

You need enough room for the base unit's telescopic aerial to be fully extended.

For the best operating conditions, try to place the base unit away from large metal objects and other electrical appliances.

Check that your Freestyle 1100 Plus is complete, when you unpack you should have:

- Cordless handset.
- Base-unit with attached telephone line cord and telescopic aerial.
- Power adaptor.
- 2 screws + 2 wallplugs for wall mounting.
- Spare memo card.
- Wall bracket.
- Quick reference guide.
- Phone-in card.

Electrical storm warning

Note 1.

Please note that during periods of electrical storm, you are advised to disconnect your apparatus because damage may occur.

Note 2.

If a fault occurs during the 12 month warranty period and it is due to accidental or wilful damage (including lightning and electrical damage) BT will not replace or repair free of charge.

Like all cordless phones, your Freestyle 1100 Plus handset will need charging for 24 hours before use.

1 Handset aerial

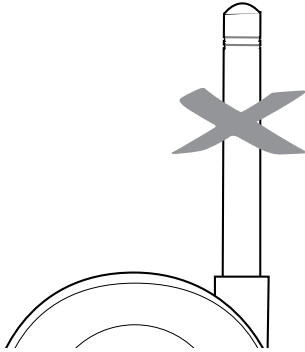

Your Freestyle 1100 Plus uses a compact aerial which *does not* pull out.

2 Check your telephone wall socket

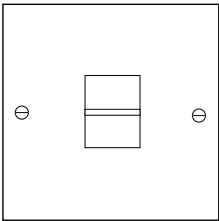

If you do not have a modern phone socket, call BT on **Freefone 0800 800 150** and ask for an engineer to come and fit the right socket within two metres of a mains socket.

3 Insert battery (for back-up only)

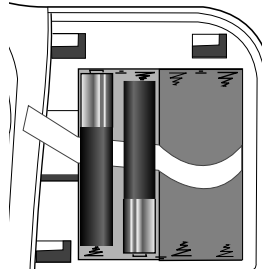

Remember that the flat ends of the batteries should be pressed against the springs.

If the Freestyle 1100 Plus is your only telephone, you should fit back-up batteries so that your telephone can always be used in emergencies.

The base-unit battery cover which is located at the top right of the base can be removed by sliding it to the right as far as it will go and lifting off. The yellow battery removal ribbon should be placed under the lower layer of batteries. Pulling on the yellow ribbon will assist in removal of the batteries when they need replacing.

Insert 6 new AAA alkaline batteries (not supplied) as shown in the diagram in the battery compartment.

Back-up batteries will only engage when the battery compartment cover is correctly replaced.

If the message display shows “L o” then you have not fitted 6 x AAA alkaline batteries correctly or the battery compartment lid has not been replaced correctly.

4 Plug the power cable into the back of the base unit

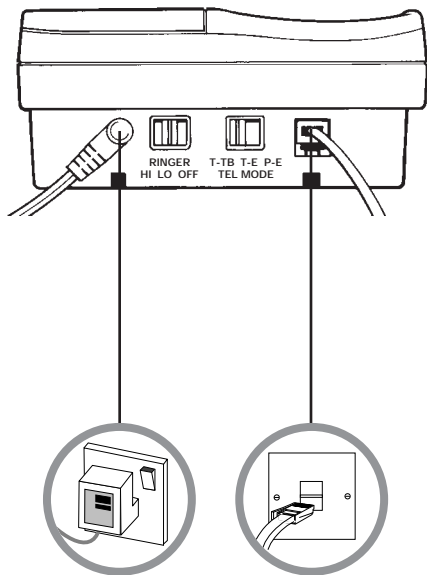

Plug the power cable into the socket on the back of the base unit.

Warnings

- 1 Do not try to use any power supply other than the one provided. This may permanently damage your Freestyle 1100 Plus.
- 2 Your Freestyle 1100 Plus should not be fitted in wet or damp conditions, for example in a bathroom. Also, the handset should not be left out in the rain.
- 3 There is a slight chance that your phone could be damaged by an electrical storm. We recommend that you unplug the base unit from the mains during storms.

5 Connect the base-unit three-pin adaptor to a power socket

6 Plug the phone into the BT socket

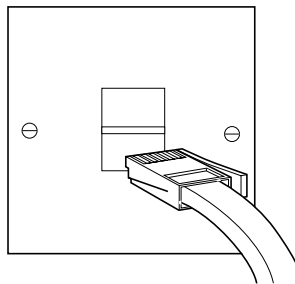

You can now use the telephone and store numbers in the memory.

7 Extend the base unit telescopic aerial

Extend the base unit telescopic aerial on your Freestyle 1100 Plus (as shown below) to ensure the best possible signal and reception.

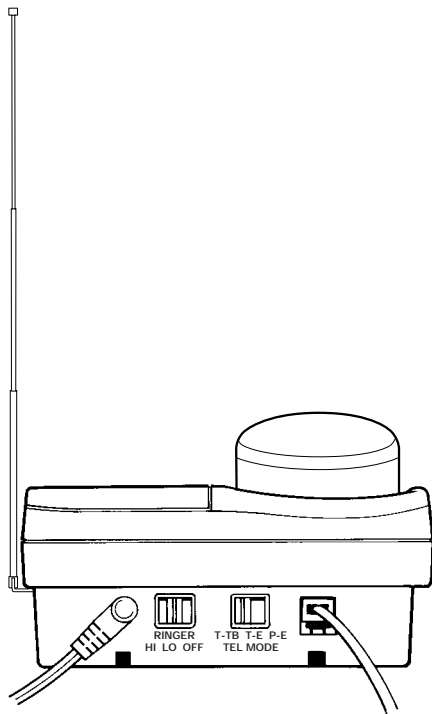

8 To wall-mount your product

(See page 41 section wall-mounting.)

To plan the location of the base unit

Your Freestyle 1100 Plus works by sending and receiving radio signals between the base unit and the handset. The strength of the signal will depend on where you site the base unit and how the aerial is deployed. The higher the base unit is located the better. An upstairs room is ideal. The following points should be considered:

- It should be within easy reach of a mains socket and a telephone socket. A new style telephone socket is required for this product. If you do not have one, call us on **Freefone 0800 800 150**.
- Try to avoid locations near metallic obstructions or electrical appliances, such as: TV sets, fridges, computers, fluorescent lights, radiators, metal pipes and metal window frames.
- The Freestyle 1100 Plus can be wall mounted by using the bracket and screws supplied, see *page 42 for template*.

For the best reception

Try to avoid putting the telescopic aerial near other electrical appliances, fluorescent lights and large metallic objects such as cookers, radiators and garage doors as these may cause interference and reduce the quality of your calls.

Before you can use your Freestyle 1100 Plus for the first time, you must charge the handset for 24 hours.

To charge the handset

- Insert the power adaptor into the mains socket and the jack plug into the 12v ac socket at the back of the base-unit.
- The unit will display “PF” followed by a countdown from “36.” When the countdown reaches “00” the unit will beep and announce the current setting of the **ANS DELAY** switch, see *page 21*.
- Place the handset on the base-unit, the **CHARGING** light will come on and the display will flash “L 0”.
- Fully extend the base unit telescopic aerial vertically.
- Do not plug the Freestyle 1100 Plus into the telephone socket, leave your existing telephone connected so that you can still make and receive calls.

The Freestyle 1100 Plus must only be used with the adaptor supplied.

Using any other adaptor will result in non-compliance with EN60950:1992, and will invalidate the approval given to this apparatus.

- You must now charge the handset for 24 hours before use.

To adjust the volume



When you are listening to your Freestyle 1100 Plus' voice prompts or messages, you can use the volume button to adjust the volume.

- Repeatedly press and release the end of the key with the larger symbol to increase the volume.
- Repeatedly press and release the end of the key with the smaller symbol to decrease the volume.

Using your Freestyle 1100 Plus

To make a call



- Pick up the handset.
- Press the TALK button on the handset. The CHANNEL SEEKER light will flash as the telephone searches for the best radio channel. When it goes out, the IN USE light on the base-unit and the TALK light will come on.
- Listen for the dialling tone. On some exchanges there may be a delay of a few seconds before the dialling tone is heard. Dial the telephone number. You will hear a beep each time you press a key.
- After your call, either press the TALK button again, or replace the handset on the base unit.

An Inductive Coupler has been built into the handset to improve sound quality for people using hearing aids. Switch your hearing aid to T and adjust the position of the handset until you get the best reception.



To switch from Pulse to Tone signalling during a call



If you are connected to a pulse dialling exchange, you can still use services such as phone banking that require tone signalling.

- Call the telephone number you require in pulse mode as usual.
- When you have been connected, press the * button on the keypad to set your telephone to tone signalling for the duration of the call.
- When you hang up, your Freestyle 1100 Plus will automatically switch back to pulse dialling.

The Freestyle 1100 Plus handset has a range of up to 250 metres from the base-unit, depending on local conditions.

If you move out of range while using the telephone, you will hear four beeps.

If you do not move back into range the telephone will repeat the warning a further five times before cutting off the call.

To answer a call



When the handset is on the base unit

When you receive an incoming call, the IN USE light will flash and the base-unit will ring.

- Pick up the handset, the CHARGING light will go off, the IN USE light will remain on but stop flashing and the TALK light will come on. Do not press the TALK button.
- After your call, either press the TALK button, or replace the handset on the base unit.

When the RINGER switch is set to OFF, the base-unit will not ring.

Your Freestyle 1100 Plus has a back-lit keypad that will come on or flash in use, to assist you when the light is poor.

When the handset is not on the base unit

The handset does not need to be on the base unit to receive a call. When you receive an incoming call, the IN USE light will flash and the CHANNEL SEEKER light on the handset will flash momentarily, then the handset will ring and the TALK light will flash.



- To answer the call, pick up the handset and press the TALK button. The IN USE light and the TALK light will remain on but stop flashing.
- After your call, either press the TALK button again or replace the handset on the base.

To use the Channel seeker



Your Freestyle 1100 Plus automatically scans all the available radio channels for quality of reception, and selects the best one to use. If you experience interference during your call, press the CHANNEL SEEKER button to select a different channel.

The channel seeker light will flash until the selection has been made, you may then continue with your call.

To set the ring mode switch

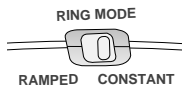

The ring mode switch on the side of the handset can be set to either:

- **RAMPED** (gradually increasing volume) or
- **CONSTANT** (constant volume).

The constant mode should only be used if the telephone is connected as an extension to a PBX. Under any other condition the switch ought to be set to ramped to prevent the possibility of damage to the user's hearing if the handset is close to the ear when it rings. Do not hold the handset to the ear when in standby mode.

To set the tel mode switch (located at back of base unit)

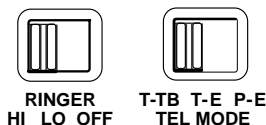

The tel mode switch (located at back of base unit) selects tone or pulse dialling and earth or time break recall:

- **T-TB** – Your Freestyle 1100 Plus is preset to this position. Most modern exchanges use tone dialling and time break recall for faster dialling, and for services such as BT's Select Services and telephone banking.
- **P-E** – If you dial a number when your Freestyle 1100 Plus is set to T-TB or T-E and you continue to hear the dialling tone, you may be connected to an older pulse dialling exchange. Set the switch to P-E (pulse dialling).
- **T-E** – This setting is for use if you are connected to a tone dialling PBX (private branch exchange) that uses earth recall.

To set the ringer switch

There are 3 settings to choose from:

- **HI** – a loud ring, your Freestyle 1100 Plus is preset to this position.
- **LO** – a quiet ring.
- **OFF** – no ring (the handset will still ring if it is not on the base-unit).

To recharge the handset

The base-unit must be connected to the mains supply at all times to recharge the handset, it will not overcharge if you leave it on the base-unit. When the handset is not on the base-unit, it will last for up to 5 hours in use or 72 hours on standby. Keeping the handset on the base-unit overnight will keep it charged for normal use.

To warn you to replace the handset on the base-unit for recharging:

In standby mode (the handset is off the base but not in use)

- The handset BATT LOW light will flash.

If you are making or receiving a call

- The handset will beep.

The handset must be correctly placed on the base unit and the charging light must be on for the handset to recharge.

See the maintenance section for instructions on how to care for the rechargeable battery pack in the handset, see page 38.

To use the **SECURITY** button



During a call you can press the **SECURITY** button on the handset to prevent the other party from hearing a private conversation with someone else in the room.

- Press and release the **SECURITY** button. The TALK light will flash, you can hear the other caller but they will not be able to hear you.
- Press and release the **SECURITY** button again to continue your call.

The **SECURITY** button does not function when using the INTERCOM.

To automatically Redial

Your Freestyle 1100 Plus automatically remembers the last number dialled.

- Press the **TALK** button and listen for the dialling tone.
- Press the **REDIAL** button. The last number dialled will be redialled automatically.

To insert a Pause



With some switchboards, after dialling the access code you may have to wait for a moment while the switchboard picks up an outside line. If this is the case, press the **REDIAL** button before keying in the telephone number to insert a pause.

To use the Recall button

This button signals either time-break recall or earth recall depending on the setting of the TEL MODE switch, see *page 12*. If you are connected to a PBX (Private Branch Exchange), contact your PBX supplier for further information. The recall button when set to time-break recall **T-TB** is also used for BT's Select Services. For further information, see *page 27*.

To use the Memory functions

The handset can store ten telephone numbers of up to 20 digits in memory. You can dial any of these numbers by pressing two buttons.

To store a number in a memory

- Pick up the handset and ensure that the TALK light is not on.
- Press the **MEMORY** button. The button pad will light up.
- Press one of the number buttons 0-9. This gives you the location code under which your number will be stored.
- Enter the telephone number.
- Press the **MEMORY** button again. You will hear a long confirmation beep. The telephone number is now stored.

Repeat this procedure for any number you want to store, using a different code number 0-9 for each one.

*Stored numbers can include switchboard and Select Services using **★** and **#** buttons as well as pause and recall.*

Keep a record of which 0-9 code you have used for each number on the handset memory label. You can take out the card by removing the handset battery compartment cover and sliding out the transparent cover.

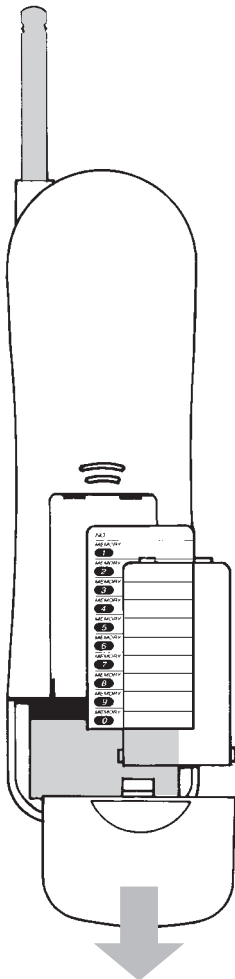

To dial a number stored in a memory

- Pick up the handset.
- Press the **TALK** button.
- Check for dial tone.
- Press the **MEMORY** button.
- Press the appropriate code number 0-9.
Your number will be dialled automatically.

To store a number of more than 20 digits

- Store the first 20 digits in a memory location as shown above.
- Then press the **MEMORY** button again and repeat the procedure to store the rest of the digits in a second memory location.

To dial a stored number of more than 20 digits

- Follow the procedure shown above, pressing the appropriate 0-9 code for the first part of the telephone number.
- When the first part of the number has been dialled, press the **MEMORY** button again and the appropriate 0-9 code for the second part of the number.

Storing a number in memory automatically overwrites any previous number stored in that location.

To change a number

Any existing number stored in the memory can be over-written by entering a new number under the same location code. Simply follow the steps shown in “To store a number in the memory”, see *page 14*.

The Call Waiting button

Only used if you have subscribed to BT's Select Services, see *page 27*.

To use Call Return

- Pick up the handset.
- Press the **TALK** button.
- Press the **MEMORY** button.
- Press the **★** button, the exchange will announce the number of the last caller if it is available.
- If you wish to call this number, press the **3** button, the number will be dialled automatically.

Call Return is a free BT Select Service (which may be available in your area) that enables you to obtain the telephone number of your last caller, provided they are also BT subscribers.

To use the Intercom



To call the handset from the base-unit

- Press the **INTERCOM** button on the base-unit. The base-unit and handset will beep and the **INTERCOM** lights on both will flash.
- To answer the **INTERCOM** call, press the **INTERCOM** button on the handset.
- You can now speak using the handset and the microphone located next to the **ANSWER ON/OFF** key on the base-unit.
- To end the call, press the **INTERCOM** button on either the base-unit or the handset. Both **INTERCOM** lights will go out.

Pressing the **INTERCOM** button on the base-unit is also a useful way of locating a misplaced handset.

*You cannot use the intercom while a telephone call is in progress.
The intercom will beep for 60 seconds and then automatically cut off if not answered.*

To call the base-unit from the handset



- Press the **INTERCOM** button on the handset. The base-unit and handset will beep, the INTERCOM lights on both will flash.
- To answer the INTERCOM call, press the **INTERCOM** button on the base-unit.
- You can now speak using the handset and the microphone located next to the **ANSWER ON/OFF** button on the base-unit.
- To end the call, press the **INTERCOM** button on either the base-unit or the handset. Both INTERCOM lights will go out.

You will not miss any incoming calls while the INTERCOM is in use.

If an incoming call is received, the base-unit will ring normally and can be heard through the handset. To answer the call press the **TALK** button on the handset, the intercom will be cut off.

To set the PIN code

Your Freestyle 1100 Plus can be accessed remotely, by using the preset PIN code of 0,0,0. This allows access to the answering machine from another telephone, see *page 25*.

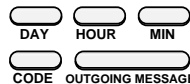

If you wish to change this code

- Press and hold the **CODE** button until the unit announces, “*Code setting... zero*”.
- Press and release the **HOUR** button until you reach the number you want for the first digit of your PIN code.
- Press the **CODE** button. The unit will announce “*Accepted*” and then “*Zero*” for the next digit.
- Press and release the **HOUR** button until you reach the number you want for the second digit of your PIN code.
- Press the **CODE** button. The unit will announce “*Accepted*” and then “*Zero*” for the last digit.
- Press and release the **HOUR** button until you reach the number you want for the last digit of your PIN code.
- Press the **CODE** button. The unit will announce “*Accepted*” and announce and display the new PIN code.

If you do not follow the procedure correctly the unit will announce “Error” and reset itself to the previous PIN code.

To check the PIN code

- Press and release the **CODE** button.
The unit will announce and display the current PIN code.

You can now write your PIN code on the Phone-in card supplied.

Using the answering machine

You can operate your Freestyle 1100 Plus answering machine from the base unit.

Your Freestyle 1100 Plus has a preset outgoing message that callers will hear. You can use this preset message, but we recommend that you record your own message stating your telephone number, or, you can use the following example:-

“Hello, thank you for calling. I am sorry that I cannot answer your call at present, but if you leave your name and telephone number, I will call you back as soon as possible. Please speak after the tone. Thank you for calling.”

To retain messages through a power cut, you will need to buy and install back-up batteries (type: AAA alkaline) in the base unit.

The base unit message display

<i>Status</i>	<i>Display</i>
The unit is receiving an incoming message or the unit has no power.	Blank
The current message number.	00 to 59
The playback of the messages has been paused.	PA
Answer functions are off.	--
Indicates that the memory is full. You must delete some messages before any new messages can be recorded.	FL flashing alternately
The back-up batteries are not installed, the batteries are low or the battery compartment cover is not fitted.	Lo flashing alternately
The unit is resetting, please wait.	PF shown first 36 countdown

To set the day and time

You do not have to follow the complete sequence, if for example you only want to change the hour, you can follow the instructions for changing the hour and skip the rest of the instructions.



- Press and hold the **DAY** button. The unit will announce, “*The day is...*”, then run through the days of the week.
- Release the **DAY** button when you reach the current day. The unit will repeat the setting and announce, “*Accepted*”.
- Press and hold the **HOUR** button. The unit will announce “*The hour is...*”, then run through the hours.
- Release the **HOUR** button when you reach the current hour. (The unit will announce, “*PM*” after twelve mid-day). The unit will repeat the setting and announce, “*Accepted*”.
- Press and hold the **MIN** (minute) button. The unit will announce, “*The minute is...*”, then run through the minutes.
- Release the **MIN** button when you reach the number of minutes past the current hour. The unit will repeat the setting and announce, “*Accepted*”.

To check the day and time

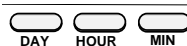

- Press and release the **DAY** button, the unit will announce the current time and day.

If you press and hold the ►► button your Freestyle 1100 Plus will give you a reminder on how to set the time/day and how to record a new outgoing message.

To listen to the outgoing message



- Press and release the **OUTGOING MESSAGE** button.

To record a new outgoing message

- Press and hold the **OUTGOING MESSAGE** button. The unit will announce, “*Please speak after the tone, release the button to end recording.*”
- Start your outgoing message after the tone, speak about 20 cm away from the microphone which is located next to the **ANSWER ON/OFF** button. The display will countdown from “*30*” to “*00*”.
- Continue to hold down the **OUTGOING MESSAGE** button until you have finished, then release the button.
- The unit will announce, “*End of recording, your outgoing message is...*” and will play back your outgoing message.

To turn the answer functions on and off



- Press the **ANSWER ON/OFF** button to turn the answer functions on or off.
- The unit will announce, “*Answer functions are on*” and the display will show “00” or, “*Answer functions are off*” and the display will show “--”.

For a good quality outgoing message record in a quiet environment so that it is free from noticeable background noise and speak clearly and continuously.

If your message exceeds 30 seconds the unit will announce, “Time out, end of recording. Your outgoing message is...” and play back the recorded part of the message.

Your outgoing message should start playing within 3 seconds of the call being answered .

To set the answer delay



You can set the number of times the telephone will ring before the Freestyle 1100 Plus answers the call. The **ANS DELAY** switch can be set to 2, 6 or TS (Time Saver), by moving the switch one step at a time.

- The 2 rings setting will be answered after approximately 7 seconds. Your Freestyle 1100 Plus is preset to this position.
- The 6 rings setting will be answered after approximately 19 seconds.
- The TS setting (Time Saver) is used to save time when accessing your machine remotely. Your Freestyle 1100 Plus answers after 2 rings if you have any new messages or 6 rings if there are none. When you call to listen to your messages, if the telephone rings a third time it means there are no messages, so hang up to save time.

For more information on remote accessing, see *page 25*.

Most callers are used to having their calls answered within 10 seconds and the majority abandon the call if it is not answered within 45 seconds.

The 2 rings setting is regarded as the normal setting and is the one we recommend.

To reset the unit

When the **RESET** button is pressed and released the unit will display “PF” followed by a count down from “36.” When the countdown reaches “00” the unit will beep and announce the current setting of the answer delay switch.

The Freestyle 1100 Plus has been preset to the following factory settings:

- The time and day has been preset to Sunday 12am.
- The outgoing message is, *“Please leave a message after the tone”*.
- All incoming messages and notes have been deleted.
- The PIN code has been reset to “0-0-0”.

To Screen incoming calls



When the answer functions are on and a caller is leaving a message, you can listen to the incoming message from the base-unit or the handset without answering. If the handset is on the base-unit adjust the **VOLUME** control if necessary, to hear the message. If the handset is not on the base-unit press the **SCREEN** button on the handset to listen to the message. If you decide to answer the call press the **TALK** button. Speak when the **CHANNEL SEEKER** light has stopped flashing

Messages and notes

To use the Note function

NOTE



Members of your household can use the **NOTE** function on your Freestyle 1100 Plus to record messages for each other.

These messages are saved with any incoming messages.

To record a note

- Press and hold the **NOTE** button. The unit will announce, *“Please speak after the tone, release the button to end recording”*.
- After the tone, speak about 20 cm away from the microphone (located next to the **ANSWER ON/OFF** button).
- Release the **NOTE** button when you have finished your message.

The number of messages shown in the display will increase by one. The note will be saved in sequential order with any previous incoming messages or notes.

To playback messages and notes



If you receive a call during playback, pick up the handset and press the TALK button. The playback will stop automatically.

You can adjust the volume of the playback with the VOLUME button.

To play all the messages and notes

- Press and release the **PLAY** button. The unit will announce the number of messages recorded, then play all the messages and notes.

To play new messages and notes only

- Press and hold the **PLAY** button for 1 second. The unit will announce the number of new messages recorded since the last time the messages were played, then play the new messages and notes.

Before each message or new message is played, the unit will announce and display the number of the message, after the message you will hear the time and day. When all the messages have been played the unit will announce, “*End of messages*”.

If you receive an incoming call during playback, you can answer the call and playback will be stopped automatically.

To stop playback

- Press the **■ STOP** button, the unit will beep and stop playing your messages. The messages will not be deleted, unless you have already pressed **DELETE**.

To pause messages and notes

- Press the **PLAY** button, the display will show “*PA*”.
- To resume playback press the **PLAY** button again. If you do not press the **PLAY** button within 30 seconds, playback will switch off.

To skip forward

- The unit will skip forward one message each time you press and release the **▶▶** button. The unit will announce “*End of messages*”, after it has played the last message.

To review messages or notes

- To repeat or restart a message, press and release the ◀◀ button during playback.

To find a specific message or note

- Press and hold down the ◀◀ button. The unit will announce the number of each message.
- Release the ◀◀ button when you reach the message you wish to review.

The Freestyle 1100 Plus cannot record an incoming message during playback.

To delete messages

DELETE



- Press and release the **DELETE** button. The unit will beep and announce “*Message deleted*”, then play any following messages.

To delete all messages and notes

When all the messages and notes have been played, the unit will announce “*End of messages*” and the message display will count down from “06” to “00.”

- Press the **DELETE** button before the count down has finished. The unit will announce “*All messages deleted*” followed by a beep.

When the message unit is full

The Freestyle 1100 Plus has a combined storage capacity of up to 14 minutes including the outgoing message. When the unit is full, the message display on the base unit will flash “FL,” and the answering machine will switch off. After 20 rings callers will hear the announcement, “*Hello your call cannot be taken at the moment, so please call later*”. To make room for new messages, or to record a new outgoing message or note, delete some of your old messages and notes.

If the unit becomes full while recording a caller's message, that caller will hear the unit interrupt, “Memory is full, answer functions are off,” before they are cut off. If someone attempts to record a NOTE when the unit is full, they will hear, “Memory is full”.

To remotely access your Freestyle 1100 Plus Your Freestyle 1100 Plus can be accessed remotely from any *TouchTone* * telephone, or any telephone using a Tone Caller available from BT shops or your supplier.

- Dial the telephone number to which your Freestyle 1100 Plus is connected.
- While the answering machine is playing your outgoing message, enter your PIN code, see *page 17*. If the entered PIN code is correct, the Freestyle 1100 Plus will beep and announce “Accepted, you have (X) new messages”, or “You have no new messages”. (If you do not hear this announcement wait for a moment and re-enter your PIN code).
- The Freestyle 1100 Plus will announce the option menu. When the option you require is announced, press the corresponding button on the keypad. The Freestyle 1100 Plus will beep and carry out the command. You do not have to wait for the end of the menu.

Once a function has been completed, you can enter another code within 8 seconds or hang up to end your call.

To skip the menu you can enter the required code at any time after your PIN code is accepted. If you can't remember the codes, refer to your Phone-in card.

A reduced menu of playback options is announced between messages. To skip this menu press 6.

The option menu is as follows:

*“For menu press 1,”**

“To play new messages press 2,”

“To set the unit on and off press 3,”

*“To play previous message press 4,”**

“To play all messages press 5,”

*“To skip message press 6,”**

“To play outgoing message press 8,”

“To record new outgoing message press 9, to stop press 9 again,”

*“To erase message press 0,”**

** Playback options announced after messages.*

Using the answering machine

- If you enter 1 either during or in between messages, the unit will return to the main menu.
- Once your messages have been played back the unit will announce, *“End of messages”*. You have 6 seconds to access another menu option before the unit ends the call.

To switch on the answering functions by remote control

If you forgot to turn the answering functions on before you went out

- Dial the telephone number to which your Freestyle 1100 Plus is connected.
- After 20 rings the unit will answer the call and play your outgoing message. You can now hang up, leave a message or enter your PIN code to access any of the remote functions. The answering functions will remain switched on.

If the unit is switched off because it is full

- Dial the telephone number to which your Freestyle 1100 Plus is connected.
- After 20 rings the unit will announce, *“Hello, your call cannot be taken at the moment, so please call later”*.
- Enter your PIN code to access any of the remote functions. You will have to delete some of your messages if you want the answering functions to remain on.

BT's Select Services

If you are connected to a digital exchange, you can subscribe to a range of BT's Select Services. If you wish to subscribe to any of these services contact us on **Freefone 0800 800 152** business, **150** residential, 8am to 6pm, Monday to Friday.

Call waiting



If an incoming call arrives while you are already engaged on a telephone call you will hear a soft beep every 5 seconds (This beep is not audible to the person you are speaking to).

Instead of the engaged tone the second caller will hear an announcement to hold on as you are aware that there is a second call.

You can answer the second call, without disconnecting your first caller, by pressing the **Call Waiting** button. The first caller will be put on hold.

When you have spoken to the second caller you can return to the first caller by pressing the **Call Waiting** button again. You can switch back and forth between the two calls without disconnecting either if you wish.

The second caller will only be charged for their call from the moment you answer and not while they are waiting for your initial contact.

Three Way Calling

Three way calling allows you to hold a conference with two other telephones, or to make a second private telephone call without disconnecting your first call.

It doesn't matter if the first call is incoming or outgoing, but the second call must be made from your telephone.

Call Diversion

Call diversion allows you to set up your telephone to divert calls to another telephone at a different location. If you are going to be away from your home or place of work and at a known location your calls can be forwarded.

There are 3 divert options available:

- All calls.
- Any calls unanswered within 15 seconds.
- Calls that come in when your telephone is engaged.

When Call Diversion is on, you will hear an intermittent dialling tone. You can still use your telephone to make calls.

Call Barring

Call Barring helps prevent unauthorised calls with a wide range of options available.

You can also stop incoming calls if you do not want to be disturbed.

Reminder Calls

You can set your telephone like an alarm clock to wake you up or remind you of an appointment. There is no rental charge.

Each Reminder costs a few pence, whether you answer it or not.

Charge Advice

You can set up your telephone to advise you of the charge for an individual call or for all calls. When you have finished a call, the exchange rings you back and tells you the length of the call and the charge. There is no rental charge for this service but you are charged for the call back.

Help

If you have any problems using your Freestyle 1100 Plus, this section will give you the most common, easy to follow solutions.

<i>Telephone problems</i>	<i>Possible cause</i>	<i>Solution</i>
<ul style="list-style-type: none"> • No dialling tone. • Telephone will not dial out. • Telephone cannot receive calls. • Beeps six times and drops calls. 	Loss of security code.	Replace handset on base unit for 10 seconds and try again. If this does not work, disconnect the handset battery from the handset for 30 minutes. Also disconnect the mains power and back-up batteries. Then reconnect the battery and reconnect the base unit to the mains, then replace the handset on the base unit for 10 seconds and try again.
	Telephone not connected to telephone line.	Plug the telephone into the telephone line.
	Mains disconnected and back-up batteries are not installed or are flat.	Reconnect and install or replace back-up batteries.
	Power cut and back-up batteries are not installed or are flat.	Wait until the power is restored and install or replace back-up batteries.
<ul style="list-style-type: none"> • You have dialling tone but the telephone will not dial out. 	Handset battery pack is discharged.	Place handset on base unit and recharge for 24 hours ensuring charge light in on.
	<p>You may be trying to use tone dialling on a pulse dialling exchange.</p> <p>You are connected to a PBX and are not dialling the access code.</p>	<p>Set mode switch to P-E (pulse dialling).</p> <p>Use the PBX access code.</p>
<ul style="list-style-type: none"> • Handset does not ring. • No lights on handset. 	Handset discharged.	Place handset on base unit and recharge for 24 hours.
	<ul style="list-style-type: none"> • Handset does not ring, but lights show on the handset. 	The handset may be set to ramped ringing. It takes 4 to 6 rings to reach maximum volume.
<ul style="list-style-type: none"> • Base unit does not ring but lights show on base unit. 	Telephone not connected to the telephone line.	Plug the telephone into the telephone socket.
	The base ringer switch is set to OFF.	Set the base ringer switch to HI or LO
	Line fault or faulty socket	Try the telephone on another socket or another line. If the telephone works contact BT or your public switched telephone network operator for repairs to the line or socket.
<ul style="list-style-type: none"> • The base-unit rings too loudly / softly 	The ringer switch on the base unit is set to HI / LO	Set the ringer switch on the base unit accordingly.

Telephone problems

Possible cause

Solution

- Neither base or handset ring, but lights show on base and handset.

Check the REN. If you connect too many telephones or devices to your line they may not all operate correctly.

If the REN exceeds 4 disconnect 1 or more telephones or devices.

If your telephone is connected to an extension socket, it may have been connected incorrectly.

Check with your telephone engineer that the extension socket has been installed correctly.

- The handset rings too loudly / softly.

The handset ring mode switch needs setting.

TOO LOUD - Set to ramped.
TOO SOFT - Set to constant.

- Callers are faint.
- Interference.
- Buzzing.
- Whooshing.

The base unit telescopic aerial is not fully extended as high as possible.

Fully extend the base unit telescopic aerial as high as possible.

You are moving out of range.

Move closer to the base unit.

Radio channel interference.

Press the CHANNEL SEEKER button on the handset, to select a clearer channel.

Radio channel interference.

Press the CHANNEL SEEKER button on the handset, to select a clearer channel.

- Tinniness.

The base unit or the handset are too close to electrical equipment or metal obstructions.

Relocate the base unit or move around with the handset until reception improves.

- No memory store.

You may be trying to store the number with the TALK light on.

Ensure that the TALK light is off before storing the number.

- Batt low light on the handset is flashing.

The handset needs recharging.

Replace the handset on the base unit, ensuring that the base unit is plugged in and that the CHARGING light is on.
(See below).

- No Charging light on the base unit.

Dirty contacts on base unit or handset.

Clean the contacts with a dry cloth. Heavy soiling can be removed with a pencil eraser.

- The intercom doesn't work.

You may be pressing the TALK button on the handset instead of the INTERCOM button.

Press the INTERCOM button.

The handset is discharged.

Recharge the handset for 24 hours.

The handset is being used to make a call.

Try again later.

It is not permitted to interfere with the main BT socket or wiring. If you have a problem, contact BT on Freefone 0800 800 151 for residential or Freefone 0800 800 154 for business lines.

The handset must only be set to constant if the telephone is connected to a suitable PBX.

<i>Answer machine problems</i>	<i>Possible cause</i>	<i>Solution</i>
<ul style="list-style-type: none"> • General Problems. 	None of the answering machine functions will operate while the telephone is in use.	Ensure that the telephone is not in use before operating the answering machine.
<ul style="list-style-type: none"> • Will not record incoming messages. • Will not answer calls. 	<p>The answering machine is switched off.</p> <p>The answering machine is full.</p>	<p>Switch the answering machine on manually or by remote control.</p> <p>Delete some or all of your messages manually or by remote control, to make room for new messages.</p>
<ul style="list-style-type: none"> • Distorted outgoing message. • Faint outgoing message. • Noisy outgoing message 	The answering machine has a very sensitive microphone. This picks up any background noise. If you record your outgoing message too quietly or from too far away the sensitivity of the microphone increases to compensate and will pick up more background noise.	Record your outgoing message at a reasonable volume 20cm away from the microphone in a quiet environment.
<ul style="list-style-type: none"> • No call screening from the base unit. • Cannot hear messages when played. 	The volume is set too low.	Press and release the end of the volume control with the larger symbol until the unit is loud enough.
<ul style="list-style-type: none"> • "Lo" flashing on the base-unit. 	<p>No back-up batteries fitted.</p> <p>Back-up batteries are flat.</p> <p>Back-up batteries are incorrectly fitted.</p> <p>Back-up battery compartment cover off, or not fitted correctly.</p>	<p>Fit back-up batteries.</p> <p>Replace all back-up batteries.</p> <p>Remove batteries and refit correctly.</p> <p>Ensure cover is replaced correctly.</p>
<ul style="list-style-type: none"> • Back-up batteries fail frequently. 	<p>Frequent power failures will drain the back-up batteries.</p> <p>Unplugging the base unit from the power supply drains the back-up batteries.</p> <p>Switching the mains supply off will drain the back-up batteries.</p>	<p>Leave the base unit plugged in, or remove the back-up batteries before unplugging.</p> <p>Do not switch off, or remove the back-up batteries before switching off.</p>

Problems

Possible cause

Solution

- **Unit will not respond to any button press.**
- **No display or display corrupted.**

Microprocessor lock up.

Press reset and set up the answering machine again. If this does not work, remove the back-up batteries unplug from the power supply for 30 seconds then plug back in, refit back-up batteries and set up the answering machine again.

- **Unit will not respond to remote control commands.**

You may be calling through a pulse dialling exchange or the telephone you are using may be set to pulse dialling.

Check that the telephone you are using is set to tone dialling. If it is connected to a pulse dialling exchange, you will need to use a tone caller.

You may be pressing the telephone buttons too quickly.

Press each key firmly and pause briefly before pressing the next key.

You may be using an incorrect access code.

Check your code when you return by pressing the CODE button.

Tone callers are available from BT shops or your supplier.

Helpline

If you are still having problems with your Freestyle 1100 Plus, call the BT product Helpline on Lo-call 0345 697146. where fully trained staff are there to assist you from 9.00am to 5.30pm Monday to Friday.

Technical Information

Official approval

The Freestyle 1100 Plus is tested and approved for connection to the BT's network, provided that it is used in accordance with the guidelines in this booklet.

You may connect it to:

- Direct exchange lines.
- Extensions with new plug and socket arrangements provided with these direct exchange lines.
- Compatible switchboards.

You may not connect it to:

- Shared service (party) lines.
- As an extension to a payphone.

This apparatus has been approved for use with the following facilities:

- Cordless telephone.
- Register recall.
- Automatic storage of last number dialled.

- Loop Disconnect/Pulse and Multi-frequency/Tone signalling.
- Microphone secrecy.
- PBXs providing secondary proceed indication.
- Memory storage of up to ten numbers.
- Intercom.
- Mixed mode dialling.
- Operation in the absence of proceed indication.
- Call screening.
- Time/day announcement.
- Selectable answering delay with time saver.

This telephone is designed for UK use only. Using it overseas may violate local radio laws.

Any other usage will invalidate the approval of the apparatus if as a result it then ceases to conform to the standards against which approval was granted.

Ringer Equivalence Number (REN)

If you connect too many telephones or other devices to your telephone line they may not ring correctly. To determine how many telephones and devices can be connected to your line, add together all the RENs of all the apparatus you wish to connect. If this total exceeds 4, they may not ring or operate correctly. The REN of your Freestyle 1100 Plus and the majority of telephones in the UK (unless otherwise marked) is 1.

Transmission Frequencies

Your Freestyle 1100 Plus can work on any of the transmission frequencies shown in the table below.

Channels	Base Unit Tx Frequency/MHz	Handset Tx Frequency/MHz
1	31.0375	39.9375
2	31.0625	39.9625
3	31.0875	39.9875
4	31.1125	40.0125
5	31.1375	40.0375
6	31.1625	40.0625
7	31.1875	40.0875
8	31.2125	40.1125

Radio Frequencies

This cordless telephone has been designed to operate on radio frequencies which have been assigned to the exclusive use of cordless telephones. As the use of cordless telephones becomes more widespread, users may experience a reduction in the quality of the service obtainable from this apparatus and problems due to radio interference may increase.

It is possible, though unlikely, that your telephone conversations may be overheard on domestic radio receivers.

Where cordless telephones are being operated near to each other and using the same radio channel, interference between them may result in users overhearing each other's calls. For this reason your Freestyle 1100 Plus can operate on 8 frequencies.

*If you experience this type of interference try changing channels using the **CHANNEL SEEKER** button on the handset.*

Connection information

- Your Freestyle 1100 Plus may be connected to public networks in the United Kingdom.
- It may also be connected to compatible switchboards. If in doubt, your switch supplier or maintainer should be able to offer help. Advice on connection to BT switching systems can be obtained by dialling BT *Freefone 0800 800 152*.

If you do not have a compatible switchboard, it cannot be guaranteed that your Freestyle 1100 Plus will operate correctly under all possible conditions of connection.

The machine cannot be used to answer calls on PBXs configured for dial 8 night services unless a suitable adaptor is purchased (not available from BT).

Safety advice

- Don't use your Freestyle 1100 Plus in the open air during thunderstorms. Unplug it from the telephone line and the mains socket when there are storms in your area.
- Don't use your Freestyle 1100 Plus outdoors in the rain, or handle it with wet hands.
- Don't install the base unit near a sink, bath or shower. Electrical appliances can cause serious injury if used when you are wet or standing in water.
- Don't install the base unit where the various leads can be tripped over or walked on. This may cause injury, or damage to the leads and your Freestyle 1100 Plus.

Guarantee

BT guarantee the Freestyle 1100 Plus to be free of defects in workmanship or materials for a period of 12 months from the date of purchase, provided:

- The goods have only been used for their intended purpose, and have not been subjected to misuse, or been wilfully or accidentally damaged.
- The goods have not been tampered with or repaired by anyone other than BT staff or agents.

Technical Information

If you are having problems with your Freestyle 1100 Plus, read the *Help* section on pages 29-32 of this User guide.

If you are still having problems you can contact the BT product helpline on **Lo-call 0345 697146** where fully trained staff are there to assist you from 9.00am to 5.30pm Monday to Friday.

If the unit is faulty within the guarantee period, return it with proof of purchase to your supplier, for repair or replacement.

If the Freestyle 1100 Plus should be in need of repair outside of the guarantee period, take the complete Freestyle 1100 Plus to any BT shop for forwarding to the repair department (there will be a carriage charge for this service).

Alternatively you can call the repair centres on **01325 304346** or **01642 564444** between 9.00am and 4.30pm, Monday to Friday.

The terms of this guarantee do not affect your statutory rights.

Maintenance

Installing handset batteries and recharging

Replacing the handset on the base unit to recharge over night should keep the Freestyle 1100 Plus operative for normal use. In time the handset battery pack will no longer hold a sufficient charge and should be replaced.

To change the handset batteries

The handset battery compartment is located at the back of the handset at the lower end.

- Firmly hold the handset in both hands with the back towards you and the bottom end away from you.
- Push the depression in the battery compartment cover, inward and away from you with both thumbs, to remove it.
- Undo the plastic belt securing the battery pack.
- Remove the old battery pack by unplugging the small white plug that connects it to the handset.
- Insert the small white plug of the new battery pack. (If you look at the shape of the plug and socket you will see that it can only be inserted one way).

- Place the battery pack in the recess, secure it with the plastic belt and refit the compartment cover.
- Replace the handset on the base unit and charge for a full 24 hours.
- The battery pack must be recycled or disposed of properly.
- Do not burn or puncture as it could release toxic material which may cause injury.

Spare parts for your Freestyle 1100 Plus are available from your BT shop or supplier, or you can contact us on Lo-call 0345 697146 from 9.00am to 5.30pm Monday to Friday.

In the event of a power failure

During a power failure, if you have fitted fresh alkaline back-up batteries in the base unit, your telephone will continue to work for up to 1 hour in use or 7 hours on standby. The answering machine will not answer incoming calls, but will retain your outgoing message and PIN code; it will also keep the day and time setting and any incoming messages or notes already recorded. The message display will remain blank and the charging light will be off.

Once power has been restored, you are advised to renew the back-up batteries in the base unit (battery replacement should not be necessary if the power has only been disconnected momentarily).

Care of rechargeable battery pack

- When you first install the Freestyle 1100 Plus, or replace the battery pack, the handset must be fully charged for 24 hours before use.
- To maintain optimum charge and battery condition, the handset should be allowed to fully discharge about every 4 months. Please note, this will delete the numbers stored in the handset's memory.
- Dispose of Ni-Cd battery packs safely. Do not puncture or burn as they contain toxic materials which could cause injury.

General cleaning

Clean the cabinet of the handset and the base with a soft cloth slightly dampened with a mild solution of water and detergent. Charging contacts should be cleaned with a dry cloth or for heavy soiling a pencil eraser can be used.

- **Do not** clean with a wet cloth.
- **Do not** clean with abrasive materials or solvents as these may damage the unit.
- **Do not** spray aerosol cleaners onto the base or handset.

Do not clean with abrasive materials.

Extended periods of non-use

It is recommended that you:

- Disconnect the base unit from both mains supply and telephone line.
- Remove the back-up batteries from the base unit and handset.
- When reconnecting, check that the **CHARGING** light on the base unit is on. Recharge the handset batteries for 24 hours.

Index

At a glance

Introduction

Emergency calls

Setting up

Aerial

Base unit

Handset

Batteries – insert into base unit

Charging the handset

Planning location

Power cable

Telephone wall socket

Volume

Using your

Freestyle 1100 Plus

Answering a call

Automatic redial

Call return

Call waiting

Channel seeker

Intercom

Base unit to handset

1	Handset to base unit	17
	Making a call	10
4	Memory	14
	Change a number	16
4	Dial	15
	Dial more than 20 digits	15
5	Memory label	15
6	Store	14
8	Store more than 20 digits	15
6	Pause	14
6	PIN (Personal Identification Number)	17
9	Checking	18
8	Setting	17
7	Pulse and Tone signalling	10
6, 7	Recall button	14
9	Recharge the handset	13
	Ringer switch volume	12
	Ring mode switch	12
	Secrecy button	13
	Telephone mode switch	12
	<i>Using the answering</i>	
	<i>maching</i>	19
16, 27	Answer delay	21
11	Answer functions On and Off	21
16	Check the day and time	20
16		

Message display	19	<i>Help</i>	29
Messages and notes	22	Helpline	32
Delete	24		
Note function	22	<i>Technical Information</i>	33
Pause	23	Connecting to a switchboard	35
Play all messages/notes	23	Guarantee	35
Playback	23	REN	34
Play new messages/notes	23	Safety	35
Record a note	22		
Record outgoing message	20	<i>Maintenance</i>	37
Review	24	Charging handset batteries	38
Skip forward	23	Installing handset batteries	37
Specific message	24	Power failure	38
Stop playback	23		
Preset message	19	<i>Wall mounting</i>	8, 41
Remote access	25	Template	42
Options menu	25		
Resetting the unit	22		
Screening	22		
Set the day and time	20		
Switching On/Off	26		
<i>Select Services</i>	27		
Call barring	28		
Call diversion	28		
Call waiting	16, 27		
Charge advice	28		
Reminder call	28		
Three way calling	27		

Wall mounting

To wall mount your Freestyle 1100 Plus
 Before you start ensure that the telephone is in easy reach of the power supply and a telephone socket.
 Ensure that the wall can support the weight of the unit.

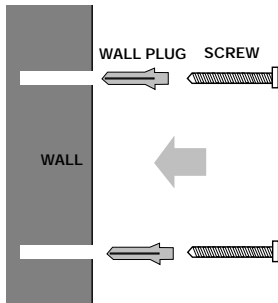

- Drill two holes for the screws and insert the wallplugs provided (if required).
- Put the screws into the wall, leaving about 5mm free to mount the stand/bracket.
- Hook the stand/bracket over the screw heads.

Clip the base unit onto the stand/bracket.

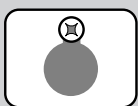

Attach the stand/bracket by hooking it over the screws protruding from the wall.

Spare parts for your Freestyle 1100 Plus are available from your BT shop or supplier, or you can contact us on Lo-call 0345 697146 between 9.00am and 5.30pm Monday to Friday.

- Use the template on the following page to mark the positions of the screws.
- Insert the screws using the wall plugs supplied if necessary, leaving a 5mm gap between the the screw heads and the wall.
- Place the wall bracket (the thin end of the wedge at the top) over the screw heads and pull down as far as possible to secure.
- Ensure that the power supply and the telephone lines are connected to the base unit, then fit the lines into the channels on the bottom of the base unit securing the lines under the small tabs.
- Any spare length of mains and telephone lead can be stored in the hollow portion of the wall bracket, but they should not be wound around each other.
- Fit the top end of the base unit over the lugs at the top of the wall bracket.
- Ensure that the lines are fitted into their slots at the bottom of the wall bracket, clip the base unit to the bottom of the wall bracket.

Wall mounting

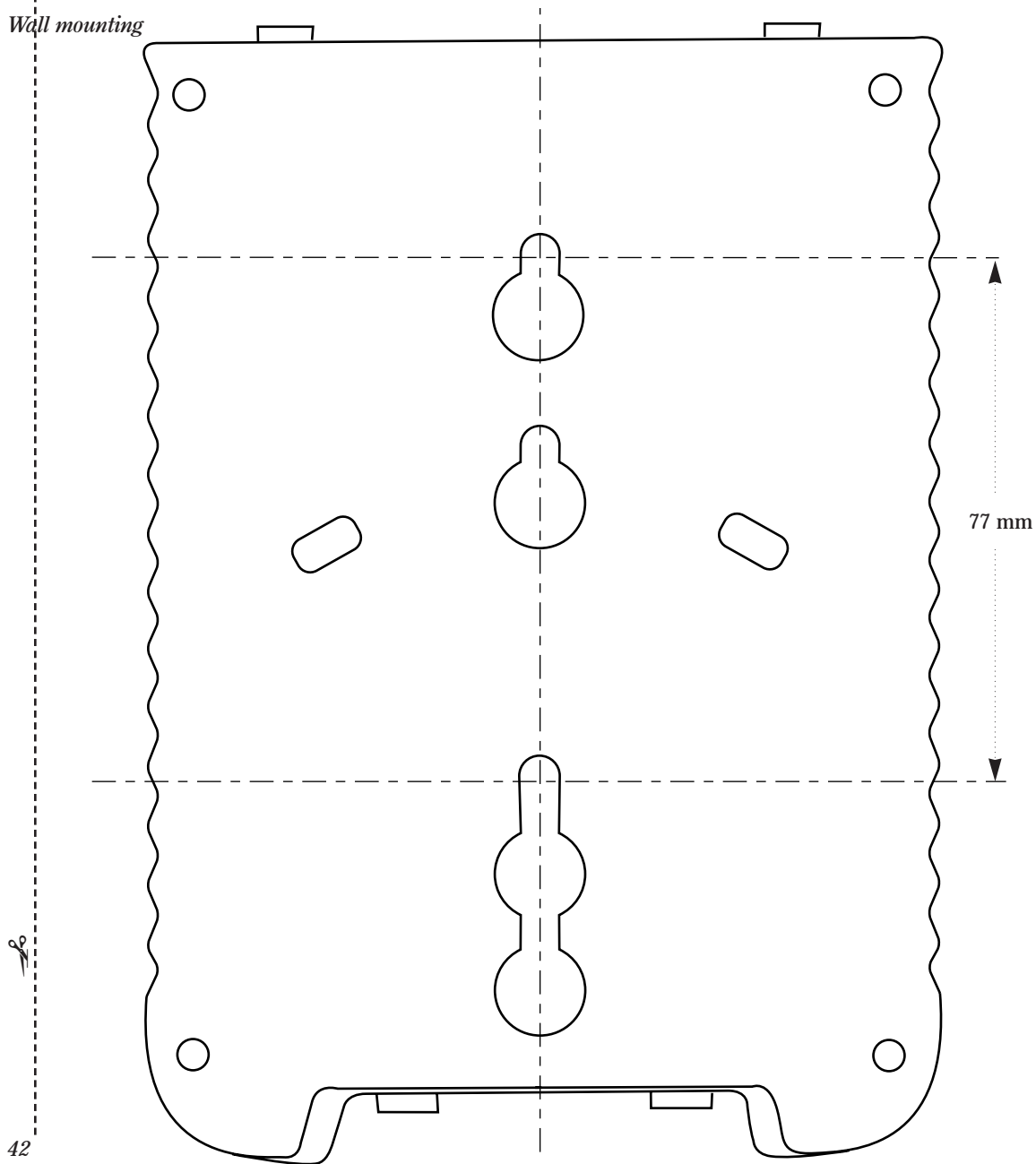

77 mm



42

Notes



*Offices in Europe, North America,
Japan and Asia Pacific.*

The services described in this publication
are not always available and may change from time to time.
We provide services and equipment under a standard contract.
Nothing in this publication forms any part of any contract.

© British Telecommunications plc 1997.
Registered Office: 81 Newgate Street, London EC1A 7AJ.
Registered in England No. 1800000.
Printed in China. Freestyle 1100 Plus Issue 1 (11/97) 5.
Designed by The Art & Design Partnership Limited.



CE compliant to 89/336/EEC
(EMC Directive) & 73/23/EEC (Low
Voltage Directive)

APPROVED for connection to
telecommunication systems specified
in the instructions for use subject to
the conditions set out in them



503680