



**ANODYNE  
ELECTRONICS  
MANUFACTURING CORP.**

## SPECIAL NOTICE

This product is now licensed to Anodyne Electronics Manufacturing (AEM) from Northern Airborne Technology (NAT). AEM is responsible for all matters related to this product, including sales, support and repair services.

Please note the transition to convert product manuals and supporting documentation is an ongoing process and is being addressed on an 'as needed' basis.

All references to NAT product part numbers (and associated images) are equivalent to AEM product part numbers.

Contact info:

**Anodyne Electronics Manufacturing Corp.**

#15-1925 Kirschner Road  
Kelowna B.C. Canada  
V1Y 4N7

Email: [support@aem-corp.com](mailto:support@aem-corp.com)

Toll Free: **1-888-763-1088**

Phone: 1-250-763-1088

Fax: 1-250-763-1089

[www.aem-corp.com](http://www.aem-corp.com)

**#15-1925 Kirschner Road, Kelowna BC Canada, V1Y 4N7**

**toll free 1-888-763-1088 t 250-763-1088 f 250-763-1089**

**[www.aem-corp.com](http://www.aem-corp.com)**



**SM09-2**

**AA83-001**  
**InterMUSIC™ Stereo Intercom System**  
**Serial No. 2938 and below**

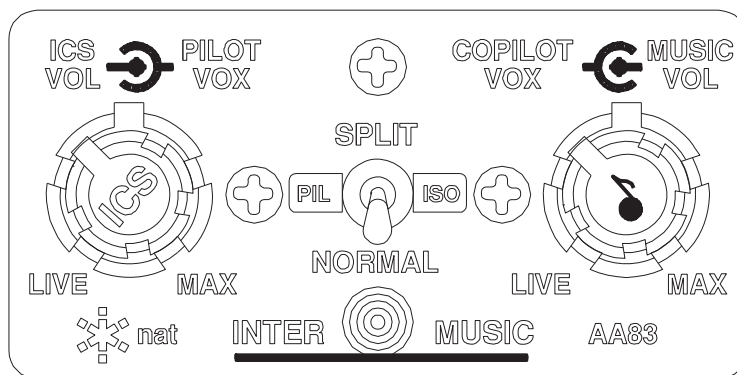

## INSTALLATION AND OPERATION MANUAL

REV 5.00 April 17, 2012

Anodyne Electronics Manufacturing Corp.  
15-1925 Kirschner Road  
Kelowna, BC, Canada.  
V1Y 4N7

Telephone (250) 763-1088  
Facsimile (250) 763-1089

Website: [www.aem-corp.com](http://www.aem-corp.com)

© 2012 Anodyne Electronics Manufacturing Corp. (AEM),  
All Rights Reserved



**AA83-001 InterMUSIC™ Stereo Intercom System  
SM09-2 Installation and Operation Manual**

---





**COPYRIGHT STATEMENT**

© 2012 Anodyne Electronics Manufacturing Corp. (AEM), All Rights Reserved

This publication is the property of AEM and is protected by Canadian copyright laws. No part of this document may be reproduced or transmitted in any form or by any means including electronic, mechanical, photocopying, recording, or otherwise, without the prior written permission of AEM.



# AA83-001 InterMUSIC™ Stereo Intercom System SM09-2 Installation and Operation Manual

Prepared By:  Tony Pearson Designer Apr 17, 2012 	Checked By:  Loen Clement Designer May 24/12 	Approved By:  Tom Betzelt Product Support Manager May 28, 2012 
--	--	---

The status of this installation and operation manual is controlled by issue shown on the title page. The status of each section is controlled by revision shown in the footer of each page. All revisions affecting sections of this manual have been incorporated into the latest issue.

<b>AEM MANUAL REVISIONS</b>			
<b>Section</b>	<b>Revision Number</b>	<b>Revision Description</b>	<b>Issue Date</b>
All	Rev 5.00	Updated template and drawings	April 17, 2012



## AA83-001 InterMUSIC™ Stereo Intercom System SM09-2 Installation and Operation Manual

### Table of Contents

Section	Title	Page
<b>1.0</b>	<b>Description</b>	
1.1	Introduction	1-1
1.2	Purpose of Equipment	1-1
1.3	Features	1-1
1.3.1	Stereo & Intercom Special Features	1-1
1.3.2	Communication Functions	1-1
1.4	Specifications	1-2
1.4.1	Electrical Specifications	1-2
1.4.2	Physical Specifications	1-3
1.4.3	Environmental Specifications	1-3
<b>2.0</b>	<b>Installation</b>	
2.1	Introduction	2-1
2.2	Unpacking and Inspection	2-1
2.2.1	Warranty	2-1
2.3	Installation Procedures	2-1
2.3.1	Warnings	2-1
2.3.2	Cautions	2-1
2.3.3	Cabling and Wiring	2-2
2.3.4	Installation Notes	2-2
2.3.5	Adjustments	2-2
2.3.6	Setting Music Input Compatibility	2-3
2.3.7	Mechanical Installation	2-4
2.3.8	Post-Installation Checks	2-4
2.3.9	Final Check	2-5
2.4	Continued Airworthiness	2-6
2.5	Accessories Required	2-6
2.6	Installation Drawings	2-6
<b>3.0</b>	<b>Operation</b>	
3.1	Introduction	3-1
3.2	General	3-1
3.2.1	Stereo & Intercom Special Features	3-1
3.2.2	Communication Functions	3-1
3.3	Controls and Indicators	3-2
3.3.1	ICS VOL/VOX	3-2
3.3.2	MUSIC VOL/COPILOT VOX	3-2
3.3.3	Annunciator	3-2
3.3.4	VOX Operation	3-3
3.3.5	Mode Switch	3-3
3.3.6	Automatic Fail-safe	3-4
3.3.7	Muting Explanation	3-5



## AA83-001 InterMUSIC™ Stereo Intercom System SM09-2 Installation and Operation Manual

---

### Section 1.0 Description

---

#### 1.1 Introduction

---

This manual contains information on the AA83-001 InterMUSIC™. All derivative products will be covered by manual supplements, which can be obtained from AEM as required. Information in this section consists of purpose of equipment, features and specifications.

#### 1.2 Purpose of Equipment

---

The AA83-001 is a 4-place stereo voice-activated intercom, providing full intercom capabilities for pilot, co-pilot and two passengers (PAX). It provides entertainment and communication audio in full stereo to all four headsets, and transceiver control for both the pilot and co-pilot. The InterMUSIC™ family of stereo intercoms allows several installation configurations – from single unit systems, to fully independent stations for the pilot, co-pilot and passengers. For expanded systems, tie line connections are compatible with other AEM systems including AA80, AA82, AMS4x and AA9x series units.

#### 1.3 Features

---

##### 1.3.1 Stereo & Intercom Special Features

---

The stereo music audio is muted during transmit or intercom operation and when radio receive audio is detected, permitting greater intelligibility of incoming transmissions. The AA83-001 muting depth adjustment ranges from complete music muting to gentle background music on command, with a fast attack and slow level return for optimum user comfort. Each microphone is individually gated, for the best possible noise performance during VOX operation. A front panel annunciator allows easy visual setting of the VOX threshold, and also indicates transmit operation.

##### 1.3.2 Communication Functions

---

The AA83-001 provides full boom-mic transmit and ICS functions for the pilot and co-Pilot, and provides ICS and radio monitor operation for two additional passengers. Pilot priority on transmit and pilot isolation (direct connection to the aircraft radio system) are standard features on all AEM intercom systems. The AA83-001 can support PTT ICS operation for all users, and can be wired to cyclic/yoke switches for both TX and ICS functions.

The balance adjustment pots permit signals to be shifted in the user's acoustic listening space so that tower transmissions appear to come from one area, and intercom from another. This greatly aids in signal recognition and more accurately reproduces a natural listening environment for the flight crew.



## AA83-001 InterMUSIC™ Stereo Intercom System SM09-2 Installation and Operation Manual

---

### 1.4 Specifications

---

#### 1.4.1 Electrical Specifications

---

Input Power		+11 to +32 Vdc. Nominal 14/28 Vdc systems
Supply Current		0.4A max. (full output power, all users)
Headset Power:		Typical 100 mW into each <b>side</b> each headset (300 $\Omega$ ear element) 4 headsets total Total maximum power 400 mW <b>per channel</b>
Indicators:		Transmit (Green LED) ICS (Amber LED)
Inputs:	4 Microphone	'carbon equivalent' 250 mVrms for full output 150 $\Omega$ input impedance
	2 TX keylines	Active ground, for Pilot & Copilot
	4 ICS keylines	Active ground, for all users
	2 music inputs	Compatible, left & right Configurable for either Walkman™/Discman™ phones compatible (3 Vp-p), or Line Output compatible (100-500 mV @ 10 k $\Omega$ )
	1 Aircraft radio input	2.5 Vrms for full output 1 k $\Omega$ input impedance
	1 bi-directional ICS Tie Line	1 Vp-p for full output 2.2 k $\Omega$ input impedance
Outputs:		4 aircraft stereo headsets (300 $\Omega$ /side) <b>Not designed for 8 <math>\Omega</math> headsets</b> 1 radio microphone output to aircraft audio panel 1 TX keyline output (hard ground for TX)
Logic:		TX, active ICS, and incoming Receive Audio all mute the music channel (Muting depth adjustable) Fast attack, slow return of music signal Pilot TX priority



## AA83-001 InterMUSIC™ Stereo Intercom System SM09-2 Installation and Operation Manual

---

### 1.4.2 Physical Specifications

---

Dimensions excluding front panel:

Height	1.30" (33.0 mm) max.
Depth	5.60" (142.2 mm) max
Width	2.60" (66.0 mm) max
Weight	0.60 lbs (283.5g) excluding external hardware
Mounting	Horizontal or vertical through-panel mounting

### 1.4.3 Environmental Specifications

---

Temperature:	
Operating	-40°C. to +70°C
Storage	-55°C to +85°C
Altitude	25,000 feet
Humidity	95% Non-condensing
Shock	DO-160C category "P", panel mounting 6 G.

End of Section 1.0

---





## AA83-001 InterMUSIC™ Stereo Intercom System SM09-2 Installation and Operation Manual

---

### Section 2.0 Installation

---

#### 2.1 Introduction

---

Information in this section consists of: unpacking and inspection procedures, installation procedures, post-installation checks, and installation drawings.

#### 2.2 Unpacking and Inspection

---

Unpack the equipment carefully. Inspect the unit visually for damage due to shipping and report all such claims immediately to the carrier involved. Note that each unit should have the following:

- AA83-001 InterMUSIC™
- Product Information Card
- Release certification
- Installation kit (Section 2.5)

Verify that all items are present before proceeding and report any shortage immediately to your supplier.

##### 2.2.1 Warranty

---

All Anodyne Electronics Manufacturing Corp. (AEM) products are warranted for 2 years. See the website [www.aem-corp.com/warranty](http://www.aem-corp.com/warranty) for complete details.

#### 2.3 Installation Procedures

---

##### 2.3.1 Warnings

---

Do not bundle any lines from this unit with transmitter coax lines. Do not bundle any logic, audio, or DC power lines from this unit with 400 Hz synchro wiring or AC power lines. Do not position this unit next to any device with a strong alternating magnetic field such as an inverter, motor or blower, or significant audio interference will result.

##### 2.3.2 Cautions

---

In all installations, use shielded cable exactly as shown and **ground as indicated**. Significant problems may result from not following these guidelines.

All audio installations can be seriously degraded by incorrect wiring and shielding, and may result in abnormal cross-talk, hum and ground-loop noise. Be especially careful with all microphone wiring and Tie Line wiring, as these lines carry the lowest level signals in the aircraft.

All microphone and headset jacks should be electrically isolated from the airframe or significant ground loop noise may result.



## AA83-001 InterMUSIC™ Stereo Intercom System SM09-2 Installation and Operation Manual

---

### 2.3.3 Cabling and Wiring

---

All unshielded wire should be to MIL-W-22759 or equivalent. For shielded wire applications, use Tefzel MIL-C-27500 shielded wire with solder sleeves (for shield terminations) to make the most compact and easily terminated interconnect. Follow the wiring diagrams in Section 2.6 as required.

Allow 3 inches from the end of the wire to the shield termination to allow the hood to be easily installed. Note that the hood is a 'clamshell' hood, and is installed after the wiring is complete. Aircraft harnessing should permit the unit to be lowered from the panel for easy access to all side adjustments. Do NOT mount the unit until all adjustments have been carried out.

All wiring should be at least 22 AWG, except power and ground lines, which should be at least 20 AWG. Ensure that the ground connection is clean and well secured, and that it shares no path with any electrically noisy aircraft accessories such as blowers, turn and bank instruments or similar loads. Power to this unit must be supplied from a separate breaker (1/2 A) or fuse (1/2 A fast), and not attached to any other existing breaker without additional protection. The correct fuse is included with the AA83-001.

### 2.3.4 Installation Notes

---

All AA95/AMS4X Audio Controllers used with the AA83-001 must have the ICS Tie Line and Gain Modifications installed. This will only be a concern on Audio Controllers with S/N 1918 or before. If the AA83-001 is used with a second unit such as an AA82, you may wish to install the 2.2 k $\Omega$  resistor shown in the installation drawing. This is used to equalize ICS Tie Line loading when changing from the tie to split connections.

If you are not familiar with Tie Line techniques, request the installation bulletin from AEM covering Tie Line theory and practice.

### 2.3.5 Adjustments

---

The unit ships from the factory with all internal adjustments set to the normal test levels. Once installed in the aircraft, it may be desirable to change some of these settings to best suit the local operating environment.

**CAUTION**

Before performing the following adjustments ensure the aircraft radio's volume control is set to produce 2.5 Vrms  $\pm$ 10 % at the input to the AA83-001, or the mute functions may not operate correctly.



## AA83-001 InterMUSIC™ Stereo Intercom System SM09-2 Installation and Operation Manual

---

The internal adjustments are located along the sides of the unit and are as follows:



### 2.3.5.1 ICS, RX, and MUSIC BAL

These potentiometers are used to adjust the headset stereo balance.

**Note:** The balance adjustment pots permit signals to be shifted in the user's acoustic listening space so that tower transmissions appear to come from one area, and intercom from another. This greatly aids in signal recognition and more accurately reproduces a natural listening environment for the flight crew.

### 2.3.5.2 ICS and MUSIC BASS

These potentiometers are used to adjust the amount of bass audio to the headsets. Rotating ccw will lower the bass level, and cw will raise it.

### 2.3.5.3 RX VOL

To reduce the receive audio volume, rotate this potentiometer ccw, and to increase the volume, rotate it cw.

### 2.3.5.4 MUSIC MUTE

The music mute level can be adjusted using this potentiometer.

## 2.3.6 Setting Music Input Compatibility

---

The AA83-001 (S/N 1091 and up) can be configured to be Low-Z or High-Z circuits by two internal jumpers (J103 and J104), which can be accessed by removing the cover and top PCB from the AA83-001. **The AA83-001 is normally shipped from the factory as a Low-Z version.**

### 2.3.6.1 Jumper Adjustment

Refer to **Component Locator** AA83\001\924-0 in Section 6 of the AA83-001 Maintenance Manual. If any further information is required, contact the Product Support department at AEM Corp.

**Note:** The AA83-001 is a static sensitive device. Use proper ESD handling procedures when the cover is removed.

The two types of music inputs are configured by the position of jumpers J103 and J104, located on the main PCB near the access hole for Q101. Music input type is determined as follows:

Low Z/Walkman™ compatible    J103 and J104 Installed

High Z/Pre-Amp compatible    J103 and J104 Removed



## AA83-001 InterMUSIC™ Stereo Intercom System SM09-2 Installation and Operation Manual

---

To gain access to the jumpers, remove the cover from the AA83-001. Remove the top PCB by removing three pan-head screws and carefully lifting it straight up.

When reassembling the unit ensure the pins and connector are aligned properly before screwing the PCB down.

### 2.3.7 Mechanical Installation

---

The AA83-001 can be installed in a vertical or horizontal attitude directly on the instrument console, using the AA83-IKC Installation kit (see Section 2.5 for details).

**Before the unit is mounted**, make all functional tests and trimpot adjustments. Be sure the harness has enough clearance to permit the unit to be dropped down for re-adjustment, if needed later. Make sure unit is securely fastened to the panel, and that the connector locks are tightened **before any flight is attempted**.

For proper installation, refer to the **Drill Template** (AA83\001\921-0) and the following steps:

**Note:** The mounting nuts on the panel pots should not be removed at any time.

- a) After deciding the attitude (vertical or horizontal) of the unit, drill the required mounting holes in the aircraft panel and insert the AA83-001 from behind the panel.
- b) Remove the protective plastic film from the black metal faceplate, and position it with the appropriate legend orientation facing out. Secure with the mounting screws provided.

**Note:** Ensure that the aircraft panel is tightly 'sandwiched' between the AA83-001 and the faceplate.

- c) Rotate the inner and outer shafts of the ICS VOL / VOX potentiometer fully ccw. The outer knob may be rotated by hand, but it may be necessary to temporarily attach the inner ICS knob to facilitate this action. Align the white markers on the knobs to the LIVE position on the faceplate label. Using a 0.05" Allen key, tighten the knobs onto the potentiometer shafts.
- d) Rotate the shaft of the MUSIC VOL potentiometer fully ccw. Align the white marker on the knob to the MIN position on the faceplate label. Using a 0.05" Allen key, tighten the knob onto the potentiometer shaft.

**Note:** Make sure there is enough clearance between the concentric knobs so that rotating one does not also move the other. A piece of paper makes a good spacer when setting up the clearance.

### 2.3.8 Post-Installation Checks

---

If any preset requires adjustment, be sure this is carried out before the aircraft leaves, and that the unit and its mating connector are secured before departure. Make all required log book entries, electrical load, weight and balance amendments and other paperwork as required by your local regulatory agency.



## AA83-001 InterMUSIC™ Stereo Intercom System SM09-2 Installation and Operation Manual

---

### 2.3.8.1 Voltage/resistance checks

**Do not attach the AA83-001 until the following conditions are met.**

Check the following:

- a) Check P101, pin <1> for +9 to +32 Vdc relative to ground.
- b) Check P101, pin <16> for continuity to ground (less than 0.5  $\Omega$ ).
- c) Check P101, pins <11> and <12> for continuity to ground (less than 0.5  $\Omega$ ) when the relevant ICS switch is keyed.
- d) Check all mic, phone, music, and key lines for shorts to ground or adjacent pins. Check all key lines for correct operation.

### 2.3.8.2 Power On checks

Install the AA83-001 and power up the aircraft's systems, and turn on the radios and accessories required. Verify normal operation of all functions. Refer to Section 3 for specific operation details.

- a) Begin with only the pilot's headset installed, no hand mic. Check for correct radio operation (both receive and transmit) and ICS operation. Check yoke (or cyclic) switch action.
- b) If there is a music source in the system turn it on and verify that music is heard in all modes except PLT ISO. Check for proper mute operation.

**Note:** Unusual buzzes, hums or other background audio may be symptomatic of multiple grounds or noisy external systems sharing the same wire bundle. Incorrect jack wiring is a common fault, especially for passenger stations, and may cause loss of audio, a tone on the headset lines, or other problems.

- c) Plug in the copilot's headset. Check for correct radio and ICS operation. Check pilot's transmit priority. Check yoke or cyclic switch functions, if applicable.
- d) Plug in the hand mic (if applicable to the installation), and test for correct operation in all modes. It must activate the transmitter(s) in all cases.
- e) Plug in any remaining headsets, and check for correct ICS operation.
- f) To verify proper operation, all functions and levels should be checked in-flight.

Be sure headsets are of good quality and are installed correctly. Unless the AA83-001 has specifically been wired for mono operation **NEVER USE MONO AIRCRAFT HEADSETS** in the system, as they will short out one side of the AA83-001 power amplifier when installed in stereo jacks. This may result in eventual unit failure, which IS NOT COVERED BY WARRANTY.

### 2.3.9 Final Check

---

Fly the aircraft and check levels and operation of all functions. You may wish to change Bass or Balance controls after flight, depending on how the system performs with regard to ambient noise.

**Upon satisfactory completion of all performance checks, make the required log entries and complete the necessary Regulatory Agency paperwork before releasing the aircraft for service.**



## AA83-001 InterMUSIC™ Stereo Intercom System SM09-2 Installation and Operation Manual

### 2.4 Continued Airworthiness

Maintenance of the AA83-001 is 'on condition' only. Periodic maintenance of this product is not required.

### 2.5 Accessories Required

Installation kit p/n AA83-IKC is required to complete the installation. The kit consists of the following:

Quantity	Description	AEM Part #
1	D-min 44 Pin Female Crimp Installation Kit	D44SL-IKC
1	AGC 1/2A Fuse	23-00-005
3	5/8" 6-32 Black Pan Head Screw	25-11-427
1	Fluted 1/8" ICS Knob	40-21-ICS3
1	Fluted 1/8" Music Knob	40-21-MUS3
1	Hole Overlay	43-10-083
1	Rectangular Faceplate	50-04-831

The AEM Part #: **D44SL-IKC** consists of:

Quantity	Description	AEM Part #
1	D-min 44 Socket Housing	20-20-044
44	Mini D Crimp Socket	20-26-703
1*	Jack Screw Set	20-27-002
1*	Lock Clip Set	20-27-004
1	25 pin Connector Hood	20-29-026

\* Use as required.

### 2.6 Installation Drawings

DRAWING	REV.	DESCRIPTION	TYPE
AA83\001\302-0	1.00	InterMUSIC System	Block Diagram
AA83\001\403-0	2.00	InterMUSIC Stereo Intercom	Interconnect
AA83\001\405-0	2.00	InterMUSIC Stereo Intercom	Connector Map
AA83\001\921-0	1.00	Drill Template	Mounting Plate

Section 2.0 ends following the above documents

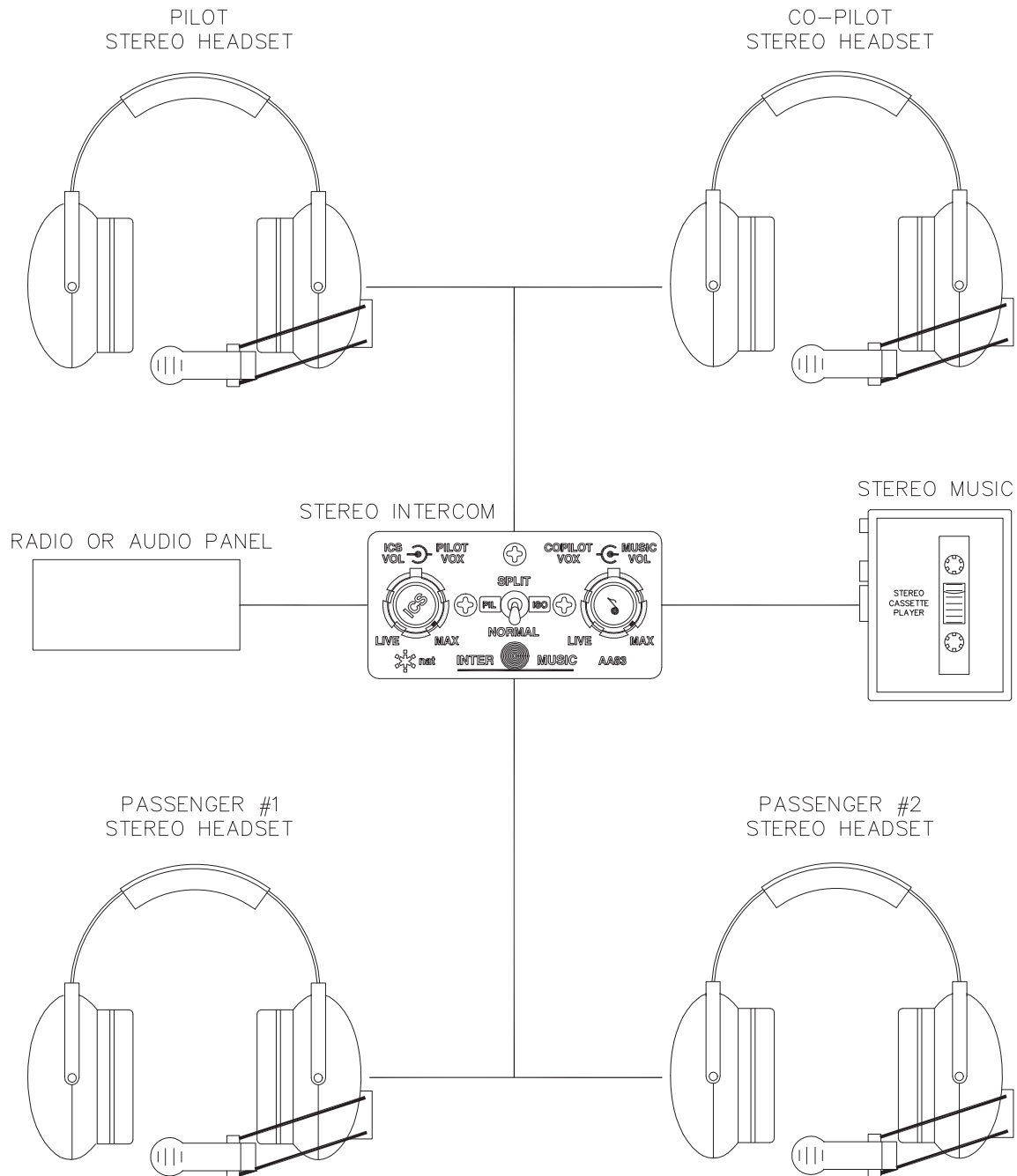

**Confidential and Proprietary to NAT**

		<b>*nat</b> NORTHERN AIRBORNE TECHNOLOGY LTD.			
REVISION	DATE	DESIGNED BY	DESCRIPTION		
1.00	MAY 6/94	K.V.	INTERMUSIC SYSTEM		
		DRAWN BY	PART NUMBER	DRAWING TYPE	SHEET
		T. MASTERS	AA83-001	BLOCK DIAGRAM	1/1
		APPROVED BY	DRAWING NUMBER	FILE NUMBER	
		<b>NAT R&amp;D</b>	AA83-001\302-0	AA83-001\302-0100	
		<b>101</b>			

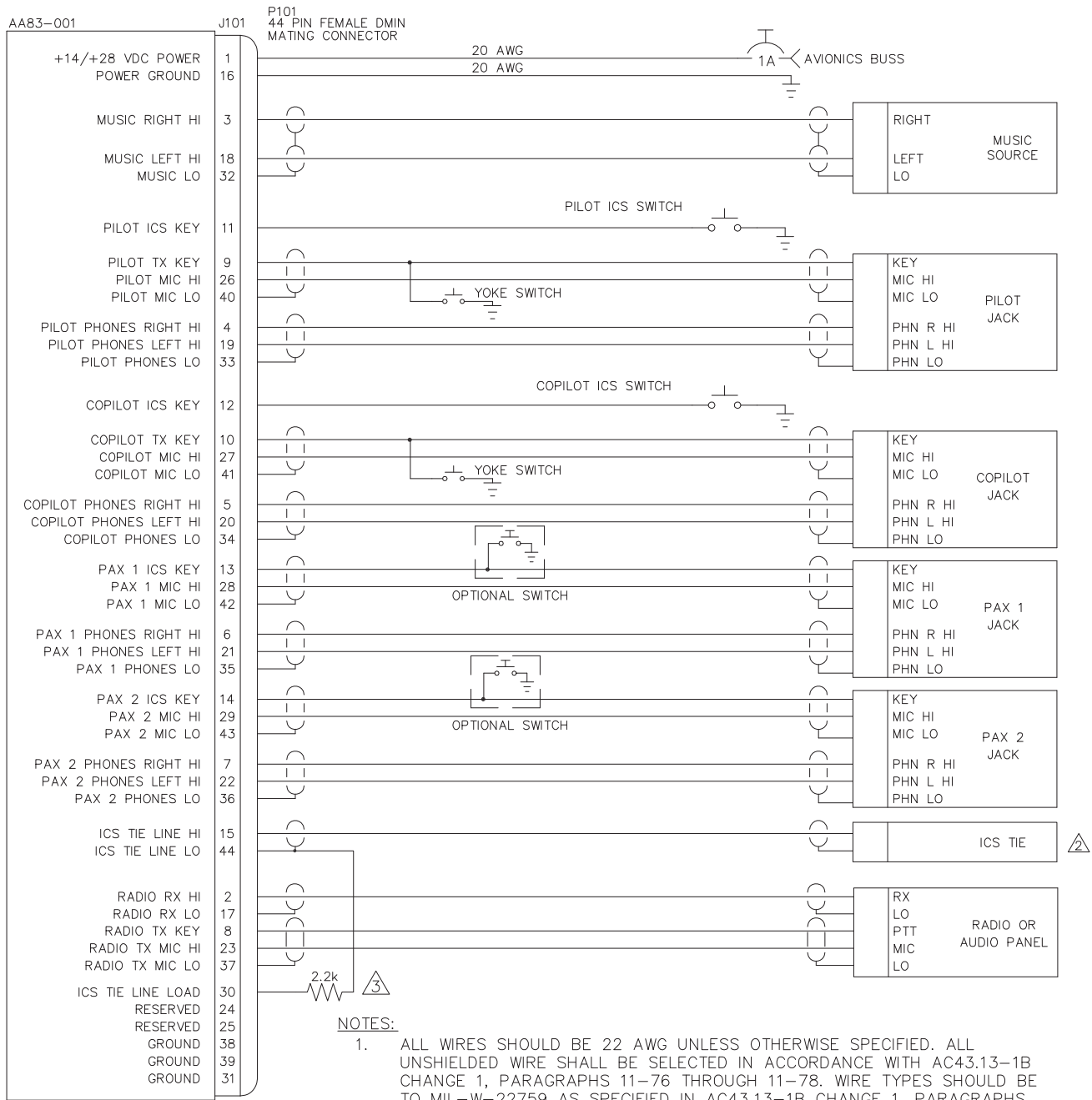

**NOTES:**

- ALL WIRES SHOULD BE 22 AWG UNLESS OTHERWISE SPECIFIED. ALL UNSHIELDED WIRE SHALL BE SELECTED IN ACCORDANCE WITH AC43.13-1B CHANGE 1, PARAGRAPHS 11-76 THROUGH 11-78. WIRE TYPES SHOULD BE TO MIL-W-22759 AS SPECIFIED IN AC43.13-1B CHANGE 1, PARAGRAPHS 11-85, 11-86 AND LISTED IN TABLE 11-11. ALL SHIELDED WIRE/CABLE SHOULD BE IN ACCORDANCE WITH MIL-C-27500.
- ⚠️ TO BE USED ONLY FOR EXPANSION OF INTERCOM SYSTEM. REFER TO INSTALLATION MANUAL FOR DETAILS.
- ⚠️ USE ONLY IN DUAL INSTALLATION TO PROVIDE CONSTANT LEVEL BETWEEN SPLIT AND NORMAL MODES.

**DEFINITIONS:**

**RESERVED:**

MAY BE CONNECTED AND USED IN FUTURE. THE CIRCUITRY MAY BE PRESENT OR ADDED TO ACTIVATE THE FUNCTION. THE PIN MAY BE USED FOR TEST PURPOSES. THERE IS NO EXTERNAL CONNECTION.

CONFIDENTIAL AND PROPRIETARY TO NAT LTD.

DESIGNED	KEH	<b>NAT</b> NORTHERN AIRBORNE TECHNOLOGY LTD.				
DRAWN	MWS					
DATE	JUL 21/05	TITLE STEREO INTERCOM				
CHECKED	<b>NAT</b> 201	<b>NAT</b> 255				
APPROVED	<b>NAT</b> 114	SIZE A	CAGE CODE 3AB01	PART NO. AA83-001	REV. 2.00	SHEET 1/1
FILE	403-0.DWG	DWG. TYPE	INTERCONNECT	DWG. NO.	AA83\001\403-0	



P101  
 44 PIN FEMALE DMIN  
 MATING CONNECTOR

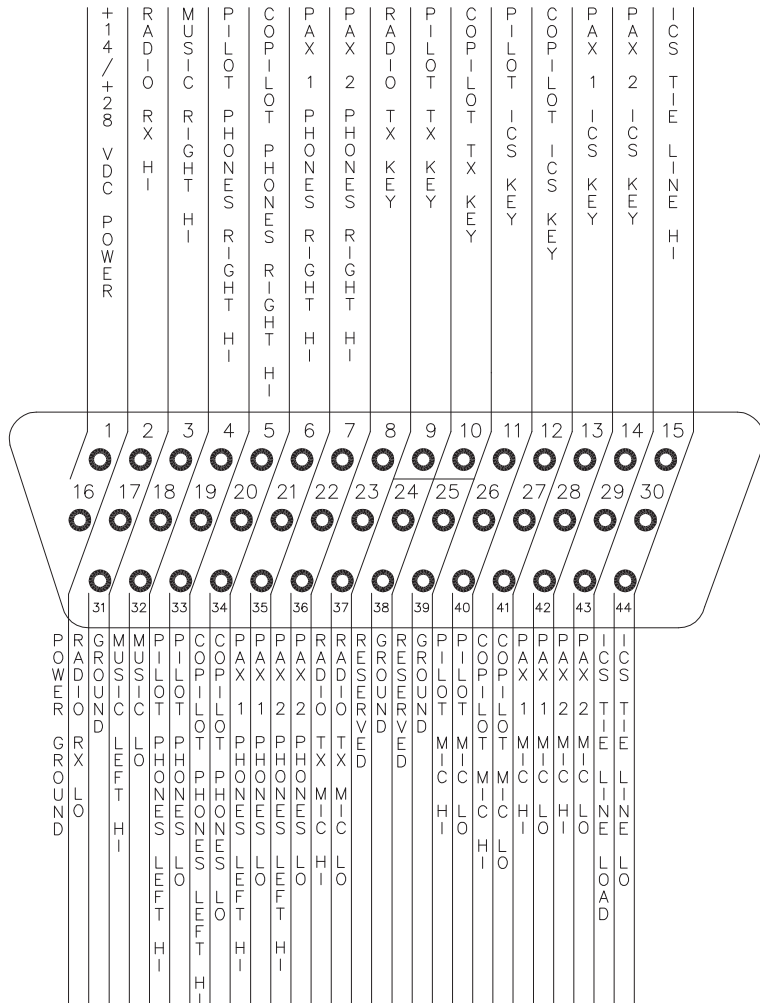

VIEW IS FROM REAR OF AIRFRAME CONNECTOR

CONFIDENTIAL AND PROPRIETARY TO NAT LTD.

DESIGNED	KEH	<b>nat</b> NORTHERN AIRBORNE TECHNOLOGY LTD.	STEREO INTERCOM			
DRAWN	MWS					
DATE	JUN 06/05					
CHECKED	<div style="border: 1px solid black; padding: 2px; display: inline-block;"> <b>NAT NAT</b>  <b>201 255</b> </div>					
APPROVED	<div style="border: 1px solid black; border-radius: 50%; padding: 5px; display: inline-block;"> <b>NAT</b>  <b>114</b> </div>	SIZE A	CAGE CODE 3AB01	PART NO. AA83-001	REV. 2.00	SHEET 1/1
FILE	405-0.DWG	DWG. TYPE	CONNECTOR MAP	DWG. NO.	AA83\001\405-0	

# AA83-001 DRILL TEMPLATE

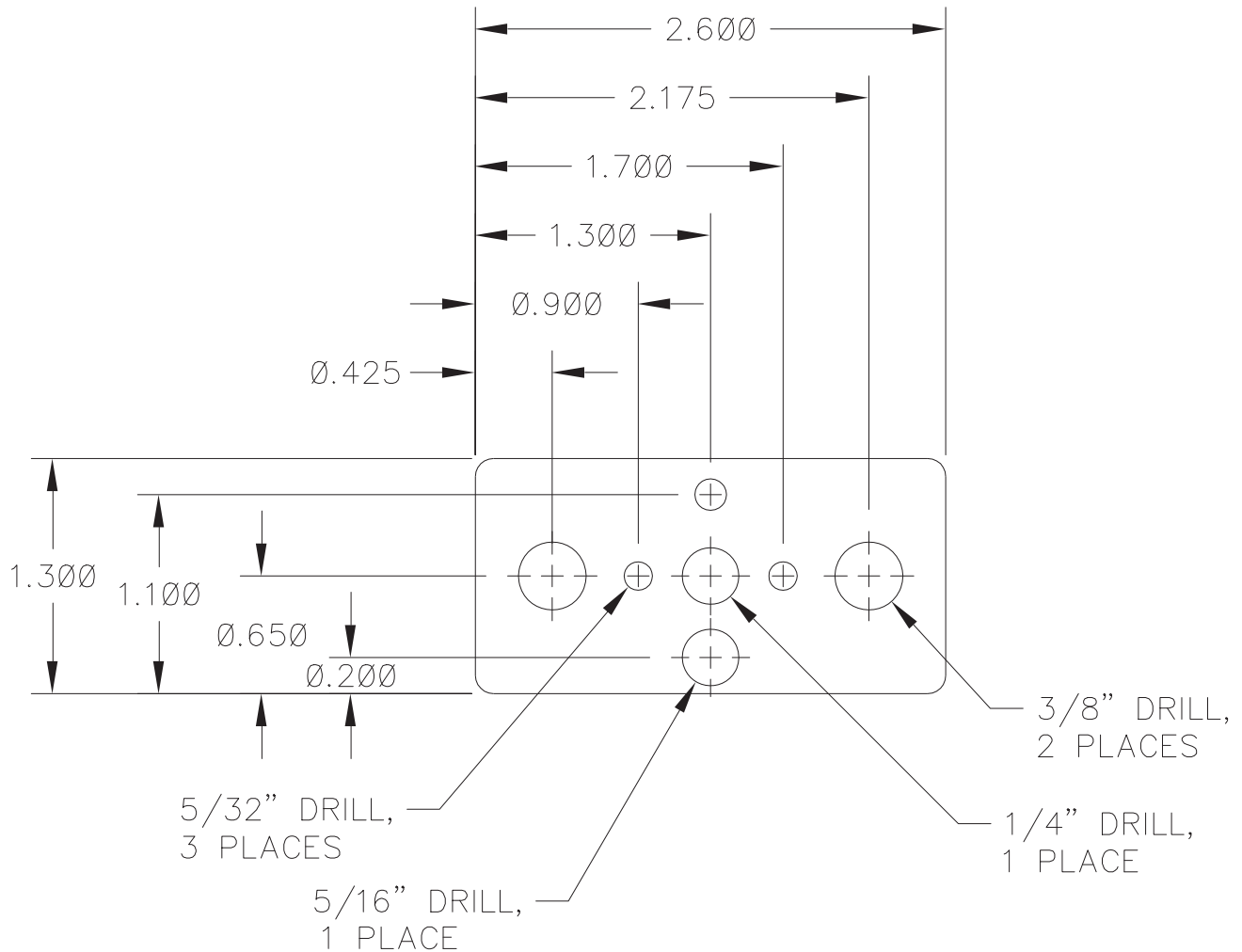

NOTE: ALL TOLERANCES  $\pm 0.01$

**Confidential and Proprietary to NAT**

REVISION	DATE	TOLERANCES UNLESS STATED OTHERWISE	<b>*nat</b> NORTHERN AIRBORNE TECHNOLOGY LTD.			
1.00	MAY 18/94	0.X=+/-0.030 DIM. IN INCHES 0.XX=+/-0.010 0.XXX=+/-0.005 0.XXXX=+/-0.0005 ANGLE=+/- 0.5 DEG.	DESIGNED BY	DESCRIPTION		
			K.V.	DRILL TEMPLATE		
			DRAWN BY	PART NUMBER	DRAWING TYPE	SHEET
			T. MASTERS	AA83-001	MOUNTING PLATE	1/1
THIRD ANGLE PROJECTION		MATERIAL/FINISH	APPROVED BY	DRAWING NUMBER	FILE NUMBER	
			<b>NAT R&amp;D</b> 101	AA83-001\921-0	AA83-001\921-0100	



## AA83-001 InterMUSIC™ Stereo Intercom System SM09-2 Installation and Operation Manual

---

### Section 3.0 Operation

---

#### 3.1 Introduction

---

Information in this section consists of the functional and operational procedures for the AA83-001 InterMUSIC™ stereo intercom.

#### 3.2 General

---

The AA83-001 InterMUSIC™ is a stereo intercom system that supports a pilot, copilot and two passengers. It provides entertainment and communication audio in full stereo to all four headsets, and transceiver control for both the pilot and copilot. The InterMUSIC™ family of stereo intercoms allows several installation configurations from single unit systems, to fully independent stations for the pilot, copilot and passengers. Tie Line connections are compatible with other AEM systems including AA82, AMS40 and AA95 series units for expanded systems.

##### 3.2.1 Stereo & Intercom Special Features

---

The stereo music audio is muted during transmit or intercom operation and when radio receive audio is detected, permitting greater intelligibility of incoming transmissions. The AA83-001 muting depth adjustment ranges from complete music muting to gentle background music on command, with a fast attack and slow level return for optimum user comfort. Each microphone is individually gated, for the best possible noise performance during VOX operation. A front panel annunciator allows easy visual setting of the VOX threshold, and also indicates transmit operation.

##### 3.2.2 Communication Functions

---

The AA83-001 provides full boom-mic transmit and ICS functions for the pilot and co-pilot, and provides ICS and radio monitor operation for two additional passengers. Pilot priority on transmit and pilot isolation (direct connection to the aircraft radio system) are standard features on all AEM intercom systems. The AA83-001 can support PTT ICS operation for all users, and can be wired to cyclic/yoke switches for both TX and ICS functions.

The balance adjustment pots permit signals to be shifted in the user's acoustic listening space so that tower transmissions appear to come from one area, and intercom from another. This greatly aids in signal recognition and more accurately reproduces a natural listening environment for the flight crew.



## AA83-001 InterMUSIC™ Stereo Intercom System SM09-2 Installation and Operation Manual

### 3.3 Controls and Indicators

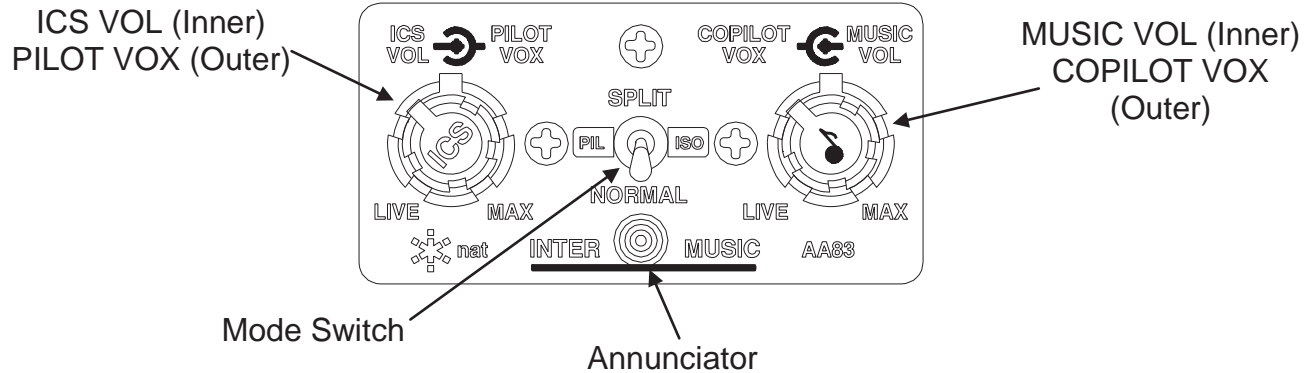

#### 3.3.1 ICS VOL/VOX

The ICS VOL/PILOT VOX control is a fluted concentric rubber knob on the left side of the front panel.

The inner (front) knob is the **ICS VOL** control, which is used to set Intercom volume. It is at minimum volume when fully counter-clockwise (ccw). As the knob is rotated clockwise (cw), the ICS volume for crew and PAX increases. The ICS is muted during transmit operations.

The outer (rear) knob is the **PILOT VOX** control. For full information on VOX operation, see section 3.3.4.

#### 3.3.2 MUSIC VOL/COPILOT VOX

The **MUSIC VOL** control is a fluted concentric rubber knob on the right side of the front panel.

The inner (front) knob is the **MUSIC VOL** control, which is used to set normal music volume. The volume is at minimum when fully counter-clockwise (ccw), and as the knob is rotated clockwise (cw), the volume increases. Music is muted during transmit operations.

The outer (rear) knob is the **COPILOT VOX** control. For full information on VOX operation, see section 3.3.4.

#### 3.3.3 Annunciator

The front panel annunciator is a bi-colour LED that shows intercom status.

If the LED is illuminated green, it indicates transmit activity, and if it is red, it indicates VOX activity. For transmit with sidetone or mic activity, it will illuminate amber. The green LED also indicates a possible stuck mic if still lit after transmission is concluded.



## AA83-001 InterMUSIC™ Stereo Intercom System SM09-2 Installation and Operation Manual

---

### 3.3.4 VOX Operation

---

The VOX control is used to set the level of audio required to activate the microphones. The AA83-001 provides three modes of intercom operation, selected by the position of the VOX control.

- LIVE ICS** When the VOX control is positioned fully ccw, the relevant mics will be live, and any sound picked up will be processed by the ICS system (hot mic).
- KEYED ICS** When the VOX control is positioned fully cw to the MAX position, the intercom will be in a keyed-only mode.
- VOX ICS** When the VOX control is positioned between fully cw and fully ccw, the intercom is in VOX mode. To establish the VOX threshold, rotate the control ccw until the LED turns red, and then rotate the control cw until the LED goes dark. Continue turning the control cw until the desired voice sensitivity is set.

### 3.3.5 Mode Switch

---

The Mode switch is a red three-position toggle switch that is used to select the operational mode of the AA83-001.

#### 3.3.5.1 Normal Mode

In normal use, the AA83-001 serves as a common intercommunication system for up to four users, and a flow-through interface for connection to the ship's external communication system. The front panel controls allow both the pilot and copilot (plus the passengers) to set their respective VOX trigger points independently to match different headsets or noise locations.

For normal operation, the **MODE** switch is set to the **NORMAL** (down) position. A transmit command from either the pilot or copilot will send their microphone signal through to the aircraft communication system. Correct operation will be indicated by the front panel indicator lighting green.

#### 3.3.5.2 Pilot Isolation Operation

In normal operation, the pilot, copilot, and passengers hear the same signals from the aircraft communication system. Sometimes this is not desirable from the pilot's perspective, such as when he needs to communicate with the tower on approach or has a heavy traffic load, and is not interested in the discussions on the intercom.

The **MODE** switch has a middle position, marked **PILOT ISO**, which disconnects the pilot from the internal amplifier of the AA83-001 and connects the pilot directly to the aircraft communication system. All other users are unaffected and continue to use the entertainment and intercom functions of the AA83-001. The pilot has no ICS or music operation when selected to **PIL ISO**, and all his signals are presented in mono format during this mode.

This mode is 'fail-passive', meaning that it requires no power to operate and is the same mode the box goes into **automatically when power is lost to the AA83-001**. In this way, switch over is immediate for the pilot and there is no possibility of lost communication because of a lack of pilot action. Note that the pilot's boom mic is sent directly to the radio in this mode, and only a PTT key input is needed to transmit.



## AA83-001 InterMUSIC™ Stereo Intercom System SM09-2 Installation and Operation Manual

---

### **3.3.5.3 Tie/Split Operation**

The **MODE** switch has one further position, which can be used in expanded systems for more complex audio circuits. If an outboard AA82 has been installed (or some other AEM system with tie line capability), then this switch will open and close the tie line output to create common or split intercom circuits with the external system.

In all positions other than **SPLIT**, the ICS tie line is sent to outside systems for common intercom operation. This can be used for common communication from front to rear (for example) in a larger aircraft. When set to the **SPLIT** position, the AA83-001 cuts the tie line, breaking the two units into individual intercom circuits with isolated conversations. In this way, many different circuit combinations can be set up, depending on what device is hooked to the tie line.

With no external unit, the **SPLIT** position has no function within the AA83-001.

### **3.3.6 Automatic Fail-safe**

---

In the event of a power failure, automatic fail-safe operation will be activated. This routes the pilot's phones, mic audio, and mic PTT directly to the COM radio. Copilot and passengers will have no ICS, music, or receive functions.

The pilot mic is directly connected to the transceiver mic. Mic bias is provided by the transceiver, not the AA83-001. The pilot TX keyline is directly connected to the transceiver.

During receive mode, receive audio is directly connected from the audio source to the pilot phones, and during transmit mode, the sidetone audio is directly connected from the audio source to the pilot phones. In both cases, copilot and passengers have no ICS, music, sidetone, or receive functions. In the unlikely event of an AA83-001 circuit failure that results in a communication problem, the automatic fail-safe mode can be enabled by pulling the AA83-001 circuit breaker.

**Note:** In Automatic Fail-Safe mode, the receive/sidetone levels may require adjustment at the audio source.

***The pilot should confirm that all aspects of Automatic Fail-Safe operation are working before accepting the aircraft into service.***



## AA83-001 InterMUSIC™ Stereo Intercom System SM09-2 Installation and Operation Manual

---

### 3.3.7 Muting Explanation

---

When transmitting, any music will be muted quickly, and will slowly return when transmission is completed. Music will also be muted when ICS or RX functions are active. The degree of muting is set via the MUSIC MUTE adjustment explained in the installation section of this manual. The relative volume of the music can be changed from the front panel by the knob marked with a musical note.

Below is a simple chart to aid in understanding audio switching in the **NORMAL** Operation mode. The following terms are used:

' Active' - Function being used.

' Muted' - Functions that are overridden by the active condition.

' Idle' - Functions that are not active, but still available for use.

Music	ICS	RX	Pilot TX	Copilot TX
Active	Idle	Idle	Idle	Idle
Muted	Active	Idle	Idle	Idle
Muted	Idle	Active	Idle	Idle
Muted	Muted	Idle	Active	Muted
Muted	Muted	Idle	Idle	Active

End of Section 3.0

---