

Rider's Manual

G 650 GS



BMW Motorrad



The Ultimate
Riding Machine

Welcome to BMW

We congratulate you on your choice of a motorcycle from BMW and welcome you to the community of BMW riders.

Familiarise yourself with your new motorcycle so that you can ride it safely and confidently in all traffic situations.

Please read this Rider's Manual carefully before starting to use your new BMW motorcycle. It contains important information on how to operate the controls and how to make the best possible use of all your BMW's technical features.

In addition, it contains information on maintenance and care to help you maintain your motorcycle's reliability and safety, as well as its value.

If you have questions concerning your motorcycle, your authorised

BMW Motorrad dealer will gladly provide advice and assistance.

We hope that you will enjoy riding your BMW and that all your journeys will be pleasant and safe.

BMW Motorrad.

Table of Contents

You can also consult the index at the end of this Rider's Manual if you want to find a particular topic or item of information.

1 General instructions 5

Overview 6

Abbreviations and symbols 6

Equipment 6

Technical data 7

Currency 7

2 General views 9

General view, left side 11

General view, right side 13

Underneath the seat 14

Instrument panel 15

Handlebar fitting, left 16

Handlebar fitting, right 17

Extra switch 18

3 Status indicators 19

Multifunction display 20

Warning and telltale lights 21

Kilometres travelled after fuel down to reserve 22

Warnings 22

4 Operation 27

Ignition switch/steering lock 28

Clock 29

Reading 30

Lights 30

Turn indicators 31

Hazard warning flashers 31

Emergency off switch (kill switch) 32

Grip heating 32

BMW Motorrad ABS 33

Clutch 34

Mirrors 35

Spring preload 35

Damping 36

Tyres 37

Headlight 38

Seat 38

5 Riding 41

Safety instructions 42

Checklist 44

Starting 44

Running in 47

speed 48

Off-roading 48

Brakes 49

Parking your motorcycle 50

Refuelling 50

Secure the motorcycle for transportation 52

6 Engineering details 55

Brake system with BMW

Motorrad ABS 56

7 Accessories 59

General instructions 60

Power sockets 60

Case 61

Topcase 63

8 Maintenance	67	Laying up motorcycle	104	11 Service	119
Notes	68	Restoring motorcycle to		BMW Motorrad service....	120
Toolkit.....	68	use	104	BMW Motorrad service	
Engine oil	68	10 Technical data	105	quality	120
Brake system	70	troubleshooting chart.....	106	BMW Motorrad mobility	
Coolant.....	74	Threaded fasteners	107	services - roadside assist-	
Clutch.....	75	Engine	109	ance.....	120
Rims and tyres	76	Fuel	110	BMW Motorrad service	
Chain.....	76	Engine oil	110	network	121
Wheels	78	Clutch.....	111	Maintenance work.....	121
BMW Motorrad front-wheel		Transmission.....	111	Confirmation of mainten-	
stand	84	Rear-wheel drive	112	ance work	122
Fuses	86	Running gear.....	112	Confirmation of service....	127
Bulbs.....	86	Brakes	113		
Air filter.....	92	Wheels and tyres.....	113		
Jump starting	94	Electrics	114		
Battery	95	Frame	116		
Body panels.....	98	Dimensions	116		
9 Care	101	Weights	117		
Care products.....	102	Riding specifications	117		
Washing motorcycle.....	102				
Cleaning easily damaged					
components.....	102				
Paint care	103				
Protective wax coating	104				

General instructions

Overview	6
Abbreviations and symbols	6
Equipment	6
Technical data	7
Currency	7

Overview

Chapter 2 of this Rider's Manual will provide you with an initial overview of your motorcycle. All maintenance and repair work on the motorcycle is documented in Chapter 11. This record of the maintenance work you have had performed on your motorcycle is a precondition for generous treatment of goodwill claims.

When the time comes to sell your BMW, please remember to hand over this Rider's Manual; it is an important part of the motorcycle.

Abbreviations and symbols



Indicates warnings that you must comply with for reasons of your safety and the safety of others, and to protect your motorcycle against damage.

 Specific instructions on how to operate, control, adjust or look after items of equipment on the motorcycle.

◀ Indicates the end of an item of information.

• Instruction.

» Result of an activity.

 Reference to a page with more detailed information.

◁ Indicates the end of a passage relating to specific accessories or items of equipment.



Tightening torque.



Item of technical data.

OE Optional extra
The motorcycles are assembled complete with all the BMW optional extras originally ordered.

OA Optional accessory
You can obtain optional accessories through your authorised BMW Motorrad dealer; optional accessories have to be retrofitted to the motorcycle.

ABS Anti-lock brake system

Equipment

When you ordered your BMW motorcycle, you chose various items of custom equipment. This Rider's Manual describes optional extras (OE) offered by BMW and selected optional accessories (OA). This explains why the manual may also contain de-

scriptions of equipment which you have not ordered. Please note, too, that your motorcycle might not be exactly as illustrated in this manual on account of country-specific differences. If your BMW was supplied with equipment not described in this Rider's Manual, you will find these features described in separate manuals.

Technical data

All dimensions, weights and power ratings stated in the Rider's Manual are quoted to the standards and comply with the tolerance requirements of the Deutsches Institut für Normung e.V. (DIN). Versions for individual countries may differ.

Currency

The high safety and quality standards of BMW motorcycles are maintained by constant development work on designs, equipment and accessories. Because of this, your motorcycle may differ from the information supplied in the Rider's Manual. Nor can BMW Motorrad entirely rule out errors and omissions. We hope you will appreciate that no claims can be entertained on the basis of the data, illustrations or descriptions in this manual.

General views

General view, left side.....	11
General view, right side	13
Underneath the seat	14
Instrument panel	15
Handlebar fitting, left.....	16
Handlebar fitting, right	17
Extra switch.....	18



General view, left side

- 1 Battery (underneath centre trim panel) (→ 95)
- 2 Engine-oil filler neck and oil dipstick (→ 68)
- 3 Seat release (in stowage compartment) (→ 38)
- 4 Tyre pressures table (on rear wheel swinging arm)
- 5 Power socket (→ 60)
- 6 Coolant level indicator (behind side panel) (→ 74)

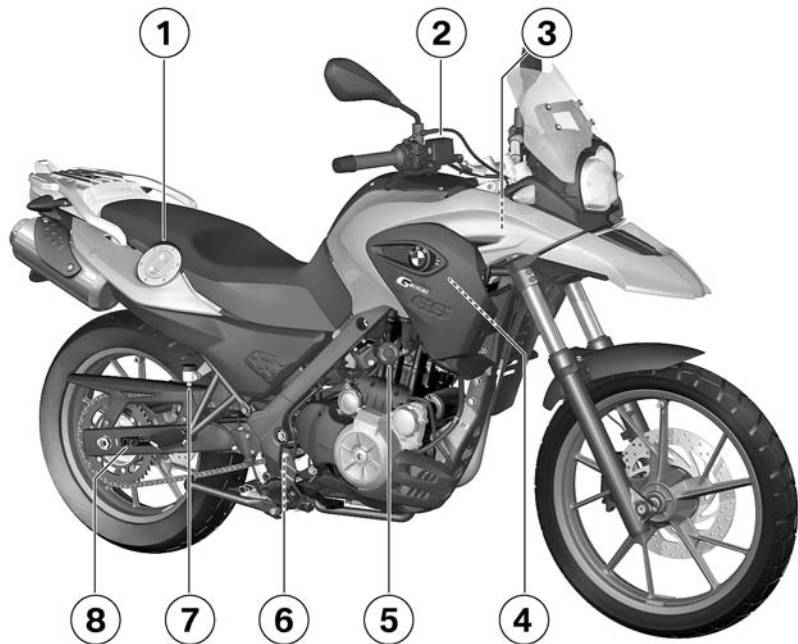

General view, right side

- 1** Fuel filler neck (➡ 50)
- 2** Brake-fluid reservoir, front (➡ 72)
- 3** Type plate (on right frame tube)
VIN (on steering-head bearing, right)
- 4** Air filter (underneath side panel) (➡ 92)
- 5** Adjuster, spring preload (➡ 35)
- 6** Adjuster for damping characteristic (➡ 36)
- 7** Brake-fluid reservoir, rear (➡ 73)
- 8** Label, chain tension (on rear wheel swinging arm)

Underneath the seat

- 1 Fuse box (→ 86)
- 2 Toolkit (→ 68)
- 3 Payload table
Tray for Rider's Manual

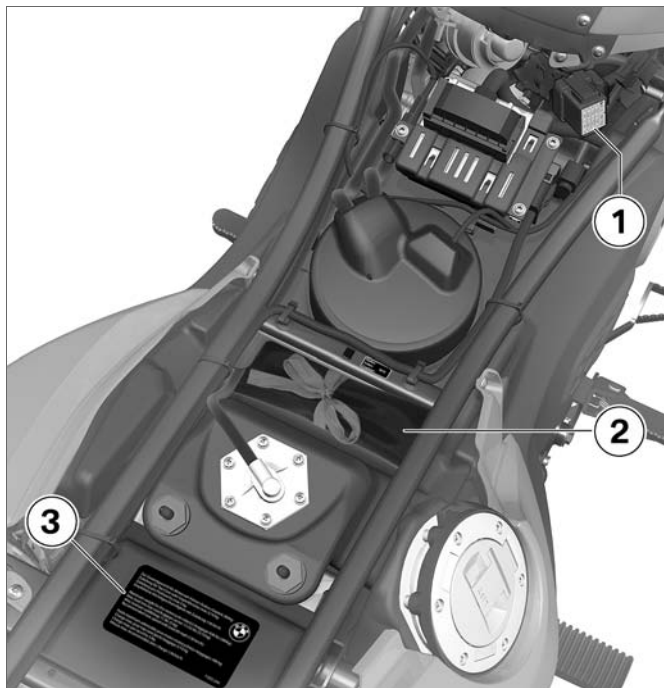

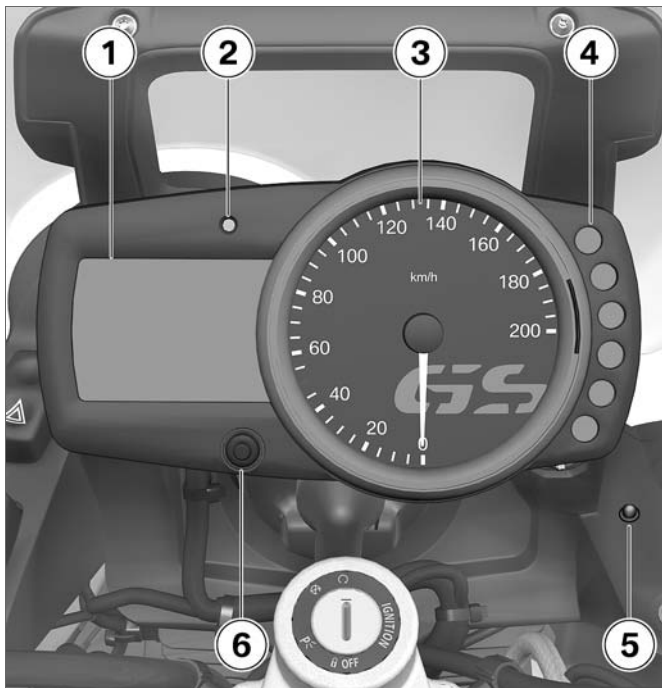

Instrument panel

- 1 Multifunction display (➡ 20)
- 2 Redline warning (➡ 48)
- 3 Speedometer
- 4 Warning and telltale lights (➡ 21)
- 5 Anti-theft alarm status LED (see the instructions for use for the anti-theft alarm)
- 6 Operation of the clock (➡ 29)
Control for the odometer (➡ 30)

Handlebar fitting, left

- 1 Headlight flasher
2 – with BMW Motorrad
ABS^{OE}

Operating the ABS
(→ 33)

- 3 Switch for turn indicators
(→ 31)
4 Horn
5 High-beam headlight
(→ 31)

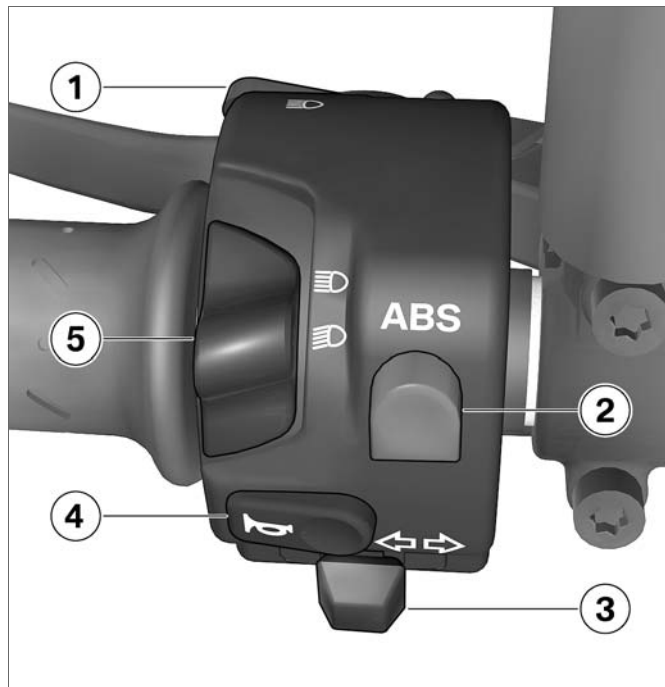

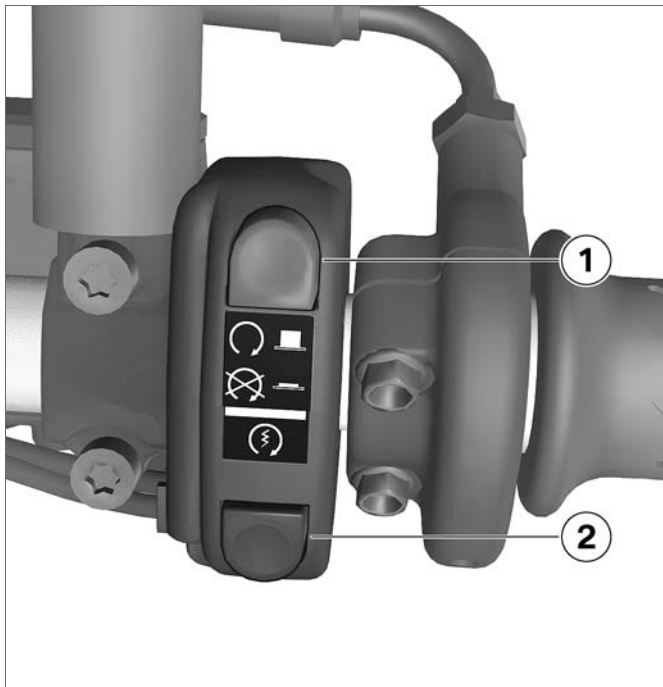



Handlebar fitting, right

- 1 Emergency off switch (kill switch) (→ 32)
- 2 Starter button (→ 45)

Extra switch

- 1 Hazard warning flashers
( 31)
- 2 – with heated handlebar
grips^{OE}
Grip heating ( 32)

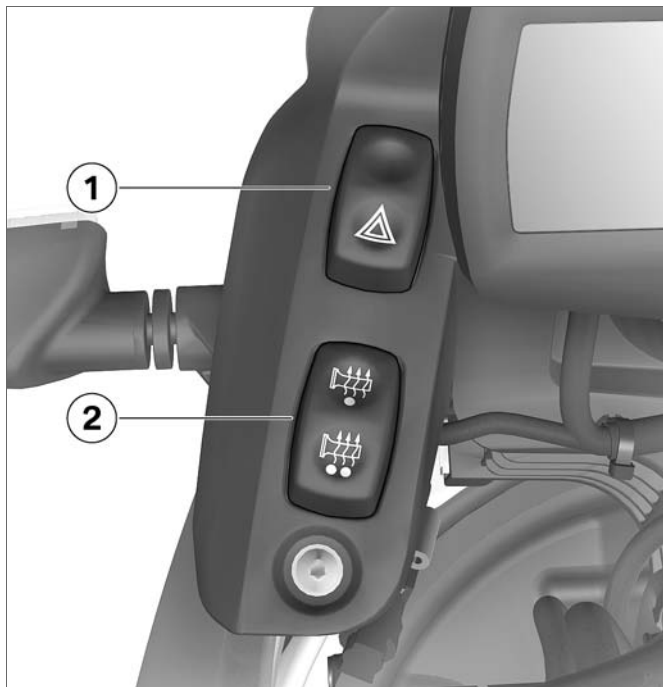

Status indicators

Multifunction display	20
Warning and telltale lights.....	21
Kilometres travelled after fuel down to reserve	22
Warnings	22

Multifunction display

- 1 Symbol for kilometres travelled after fuel down to reserve (☛ 22)
- 2 Symbol for trip meter (Trip 1 or Trip 2) (☛ 30)
- 3 Readout area for tripmeter and kilometres travelled after fuel down to reserve
- 4 Redline marker for engine rpm
- 5 Rev. counter
- 6 Clock
- 7 Symbol for setting time (☛ 29)
- 8 Total distance travelled

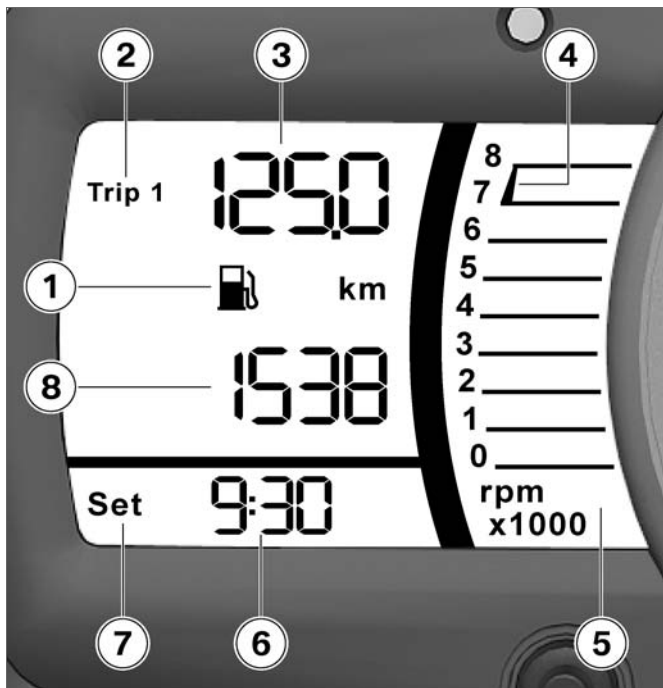



Warning and telltale lights

- 1 Telltale light for turn indicators
- 2 Warning light for fuel down to reserve (➡ 24)
- 3 Telltale light for neutral
- 4 – with BMW Motorrad ABS^{OE}
ABS warning light (➡ 24)
- 5 Coolant warning light (➡ 24)
- 6 High-beam headlight telltale light

Kilometres travelled after fuel down to reserve

The reading shows the kilometres travelled since the fuel level dropped to reserve. This counter is reset and the reading disappears as soon as refuelling brings the total quantity of fuel in the tank back above the reserve level.

You can call up the trip meter readings and the clock setting at any time.

Warnings

Mode of presentation

Warnings are indicated by the corresponding warning lights. The possible warnings are listed on the next page.

Warnings, overview

Warning light

Status indicators

Meaning



Lights up

Fuel down to reserve (→ 24)



Lights up

Coolant temperature too high (→ 24)



Flashes

ABS self-diagnosis not completed
(→ 24)



Lights up

ABS deactivated (→ 25)



Lights up

ABS fault (→ 25)

Fuel down to reserve



Warning light for fuel down to reserve shows.



Lack of fuel can result in the engine misfiring and cutting out unexpectedly. Misfiring can damage the catalytic converter; a hazardous situation can result if the engine cuts out unexpectedly.

Do not run the fuel tank dry.◀

Possible cause:

The fuel tank contains no more than the reserve quantity of fuel.



Reserve fuel

– approx. 4 l

- Refuelling (➡ 50).

Coolant temperature too high



Warning light for coolant temperature shows.



Continuing to ride when the engine is overheated could result in engine damage.

Compliance with the information set out below is essential.◀

Possible cause:

Coolant level too low.

- Check the coolant level (➡ 74).
- If the coolant level is too low:
- Topping up coolant (➡ 74).

Possible cause:

Radiator fan defective.

If the radiator fan does not start even though the coolant-temperature warning light shows:

- Have the fault rectified as quickly as possible by a specialist workshop, preferably

an authorised BMW Motorrad dealer.

Possible cause:

Insufficient cooling.

- If possible, ride in the part-load range to cool down the engine.
- In traffic jams, switch off the engine, but leave the ignition switched on so that the radiator or fan continues to operate.
- If the coolant temperature is frequently too high, have the fault rectified as soon as possible by a specialist workshop, preferably an authorised BMW Motorrad dealer.

ABS self-diagnosis not completed

– with BMW Motorrad ABS^{OE}



ABS warning light flashes.

Possible cause:

The ABS function is not available, because self-diagnosis did not complete. The motorcycle has to move forward a few metres for the wheel sensors to be tested.

- Pull away slowly. Bear in mind that the ABS function is not available until self-diagnosis has completed.

ABS deactivated

– with BMW Motorrad ABS^{OE}



ABS warning light shows.

Possible cause:

The rider has switched off the ABS system.

- Activate the ABS function.

ABS fault

– with BMW Motorrad ABS^{OE}



ABS warning light shows.

Possible cause:

The ABS control unit has detected a fault. The ABS function is not available.

- You can continue to ride. Bear in mind that the ABS function is not available. Bear in mind the more detailed information on situations that can lead to an ABS fault (→ 57).
- Have the fault rectified as quickly as possible by a specialist workshop, preferably an authorised BMW Motorrad dealer.

Operation

Ignition switch/steering lock	28	Headlight	38
Clock	29	Seat	38
Reading.....	30		
Lights.....	30		
Turn indicators.....	31		
Hazard warning flashers.....	31		
Emergency off switch (kill switch).....	32		
Grip heating.....	32		
BMW Motorrad ABS.....	33		
Clutch	34		
Mirrors.....	35		
Spring preload	35		
Damping.....	36		
Tyres	37		

Ignition switch/steering lock

Keys

You receive two master keys and one spare key.

Ignition switch/steering lock, tank filler cap lock and seat lock are all operated with the same key.

- with Vario cases^{OA}
- with topcase^{OA}

If you wish you can arrange to have the cases and the top-case fitted with locks that can be opened with this key as well. Consult a specialist workshop, preferably an authorised BMW Motorrad dealer. <

Switching on ignition

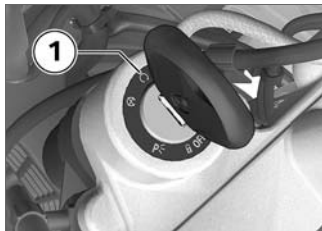

- Turn the key to position **1**.
 - » Parking light, low-beam headlight and all function circuits switched on.
 - » Engine can be started.
 - » Pre-ride check is performed. (➡ 46)
- with BMW Motorrad ABS^{OE}
 - » ABS self-diagnosis is performed. (➡ 46)

Switch off the ignition



- Turn the key to position **2**.
 - » Lights switched off.
 - » Handlebars not locked.
 - » Key can be removed.

Engaging steering lock with parking lights



If the motorcycle is on the side stand, the surface of the ground will determine whether it is better to turn the handlebars to the left or right. However, the motorcycle is more stable on a level surface with the handlebars turned to the left than with

the handlebars turned to the right.

On level ground, always turn the handlebars to the left to set the steering lock.◀

- Turn the handlebars to the full left or right lock position.

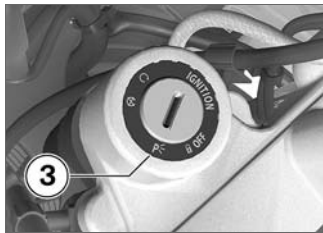

- Turn the key to position **3**, while moving the handlebars slightly.
 - » Parking lights switched on.
 - » Handlebars locked.
 - » Key can be removed.

Engaging steering lock without parking lights

- Engaging steering lock with parking lights (➡➡ 28).

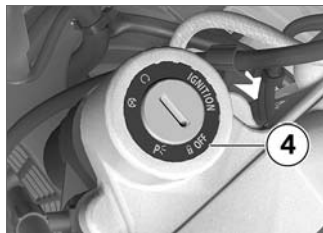

- Turn the key further to position **4**.
 - » Parking lights switched off.
 - » Handlebars locked.
 - » Key can be removed.

Clock

Setting clock

 Attempting to set the clock while riding the motorcycle can lead to accidents. Set the clock only when the motorcycle is stationary.◀

- Switch on the ignition.



- Repeatedly press button **1** until SET **2** appears on the display.
- Hold down the button until the hours number flashes.

- Repeatedly press the button until the hours number is correct.
- Hold down the button until the minutes number flashes.
- Repeatedly press the button until the minutes number is correct.
- Hold down the button until the minutes number stops flashing.
- » This completes the process.

Reading

Select the readings

- Switch on the ignition.



- Press button **1** to select the reading on the display. The following values can be displayed:

- Tripmeter 1 (Trip 1)
- Tripmeter 2 (Trip 2)
-  Kilometres travelled after fuel down to reserve
- Clock setting (SET)

Resetting tripmeter

- Switch on the ignition.
- Select the desired tripmeter.



- Press and hold down button **1** until the tripmeter reading is reset.

Lights

Parking light

The parking lights switch on automatically when the ignition is switched on.

 The side lights place a strain on the battery. Do not switch the ignition on for longer than absolutely necessary. ◀

Low-beam headlight

The low-beam headlight switches on automatically when the ignition is switched on.

 The low-beam headlight places a strain on the battery. Do not switch the ignition on for longer than absolutely necessary. ◀

High-beam headlight

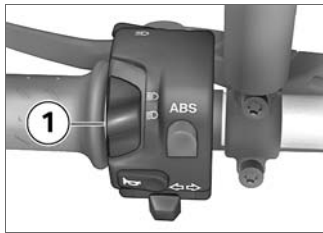

- Push switch **1** up to switch on the high-beam headlight.
- Push switch **1** down to switch off the high-beam headlight.

Headlight flasher



- Press button **1**.
» The high-beam headlight is switched on until you release the button.

Turn indicators

Operating flashing turn indicators

- Switch on the ignition.



- Push button **1** to the left to switch on the left flashing turn indicators.
- Push button **1** to the right to switch on the right flashing turn indicators.
- Centre button **1** to cancel the flashing turn indicators.

Hazard warning flashers

Operating hazard warning flashers

- Switch on the ignition.

 The hazard warning flashers place a strain on the battery. Do not use the hazard warning flashers for longer than absolutely necessary. ◀

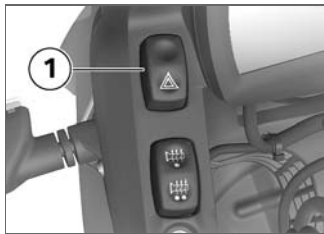

- Press bottom section of switch for hazard warning flashers **1** to switch on the hazard warning flashers.
- Ignition can be switched off.
- Press top section of switch for hazard warning flashers **1** to switch off the hazard warning flashers.

Emergency off switch (kill switch)



- 1** Emergency off switch (kill switch)

 Operating the kill switch when riding can cause the rear wheel to lock and thus cause a fall. Do not operate the kill switch when riding. ◀

The emergency off switch is a kill switch for switching off the engine quickly and easily.



- Switch in normal position: run position
- Switch actuated: engine switched off

 You cannot start the engine unless the kill switch is in the run position. ◀

Grip heating

- with heated handlebar grips^{OE}

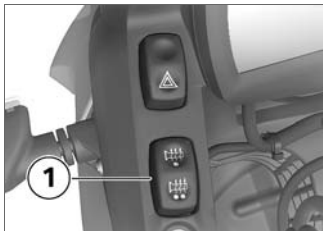

1 Grip-heating switch

The handlebar grips have two-stage heating. Stage two is for heating the grips quickly: it is advisable to switch back to stage one as soon as the grips are warm.

 The handlebar-grip heating places a strain on the battery. Do not switch on the grip heating unless the engine is running. ◀



 Press top section of switch: 50% heat output.

- Switch centred: heating function off.

 Press bottom section of switch: 100% heat output.

BMW Motorrad ABS

– with BMW Motorrad ABS^{OE}

Deactivating ABS function

- Bring the motorcycle to a stop or, if the motorcycle is at a standstill, switch on the ignition.



- Press and hold down button **1** until the ABS warning light changes status.

 ABS warning light starts to show.



- Release button **1** within two seconds.

 ABS warning light remains ON.

» The ABS function is deactivated.

Activating ABS function



- Press and hold down button **1** until the ABS warning light changes status.
-  ABS warning light goes out; if self-diagnosis has not completed it starts flashing.
- Release button **1** within two seconds.
-  The ABS warning light remains off or continues to flash.
- » The ABS function is activated.
- You also have the option of switching the ignition off and then on again.

▷ If you switch the ignition off then on again and the ABS light comes back on, there is a fault in the ABS.◀

Clutch

Adjusting clutch lever

 Attempting to adjust the clutch lever while riding the motorcycle can lead to accidents. Do not attempt to adjust the clutch lever unless the motorcycle is at a standstill.◀

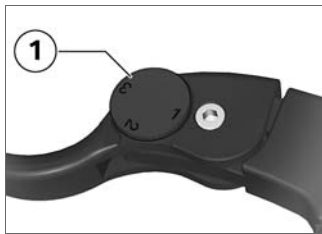

- Turn adjusting screw **1** to the desired position.

▷ The adjusting screw is easier to turn if you push the clutch lever forward.◀

» Adjustment options:

- From position 1: smallest span between handlebar grip and clutch lever
- to position 3: largest span between handlebar grip and clutch lever

Mirrors

Adjust the mirrors



 Attempting to adjust the mirror while riding the motorcycle can lead to accidents. Do not attempt to adjust the mirror unless the motorcycle is at a standstill. ◀

- Turn the mirror to the correct position.

Adjusting mirror arm

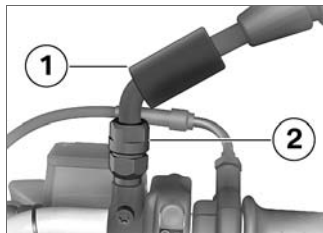

- Push protective cap **1** up over the threaded fastener on the mirror arm.
- Slacken nut **2**.
- Turn the mirror arm to the appropriate position.
- Tighten the nut to the specified tightening torque, while holding the mirror arm to ensure that it does not move out of position.

 Locknut (mirror) to clamping piece

– 20 Nm

- Push the protective cap over the threaded fastener.

Spring preload

Adjustment for rear suspension

It is essential to set spring preload of the rear suspension to suit the load carried by the motorcycle. Increase spring preload when the motorcycle is heavily loaded and reduce spring preload accordingly when the motorcycle is lightly loaded.

Adjusting spring preload for rear wheel

- Make sure the ground is level and firm and place the motorcycle on its stand.

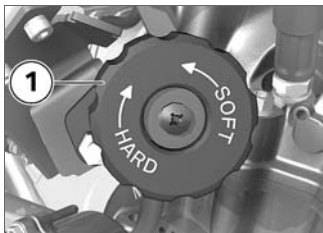

! Your motorcycle's handling will suffer if you do not match the spring-preload and damping-characteristic settings. Adjust the damping characteristic to suit spring preload.◀

! Adjusting spring preload while the motorcycle is being ridden can lead to accidents. Do not attempt to adjust spring preload unless the motorcycle is at a standstill.◀

- If you want to increase spring preload, turn knob **1** in the direction indicated by the HARD arrow.

- If you want to reduce spring preload, turn knob **1** in the direction indicated by the SOFT arrow.



Basic setting of spring preload, rear

- Turn the knob counter-clockwise to the limit stop, then turn it back 15 clicks. (Full load of fuel, with rider 85 kg)

Damping Adjustment for rear suspension

Damping must be adapted to suit spring preload and the surface on which the motorcycle is ridden. An increase in spring preload requires firmer damping, a reduction in spring preload requires softer damping. The harder the setting, the more the movement that the spring

strut can make to absorb surface irregularities is damped. When you choose a soft setting the spring strut responds all the more rapidly to surface irregularities.

Adjusting damping for rear wheel

- Make sure the ground is level and firm and place the motorcycle on its stand.



- Adjust the damping characteristic, using the tool from the on-board toolkit to turn adjusting screw **1**.

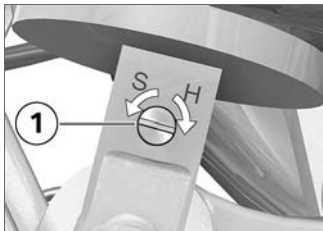

- If you want a harder damping characteristic, use a screwdriver to turn adjusting screw **1** in the direction indicated by the H arrow.
- If you want a softer damping characteristic, use a screwdriver to turn adjusting screw **1** in the direction indicated by the S arrow.



Rebound stage, basic setting, rear

- Turn the bottom adjusting screw as far as it will go in the clockwise direction and then back it off three quarters of a turn (Full load of fuel, with rider 85 kg)

Tyres

Checking tyre pressure



Incorrect tyre pressures impair the motorcycle's handling characteristics and increase the rate of tyre wear.

Always check that the tyre pressures are correct. ◀



At high road speeds, tyre valves installed perpendicular to the wheel rim have a tendency to open as a result of centrifugal force.

In order to avoid sudden deflation, fit valves installed perpen-

dicular to the rim with valve caps complete with rubber seals and make sure the valve caps are screwed firmly on to the valves. ◀

- Make sure the ground is level and firm and place the motorcycle on its stand.
- Check tyre pressures against the data below.



Tyre pressure, front

– 2.2 bar (Tyre cold)



Tyre pressure, rear

– 2.5 bar (one-up, tyre cold)

– 2.9 bar (two-up and with luggage, tyre cold)

If tyre pressure is too low:

- Correct tyre pressure.

Headlight

Adjusting headlight for driving on right/driving on left

If the motorcycle is ridden in a country where the opposite rule of the road applies, its asymmetric low-beam headlight will tend to dazzle oncoming traffic. Have the headlight set accordingly by a specialist workshop, preferably an authorised BMW Motorrad dealer.

Headlight beam throw and spring preload

Headlight beam throw is generally kept constant when spring preload is adjusted to suit load. Spring preload adjustment might not suffice only if the motorcycle is very heavily loaded. Under these circumstances, headlight beam throw has to be adjusted

to suit the weight carried by the motorcycle.

▶ Consult a specialist workshop, preferably an authorised BMW Motorrad dealer, if you are unsure whether the headlight beam-throw setting is correct.◀

Adjusting headlight beam throw

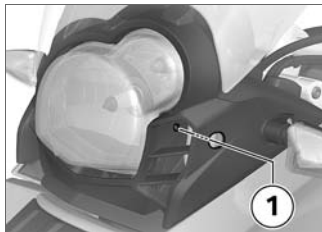

- Slacken screws **1** on left and right.
- Adjust beam throw by tilting the headlight slightly about its horizontal axis.

- Tighten screws **1** on left and right.

Seat

Remove the seat

- Make sure the ground is level and firm and place the motorcycle on its stand.

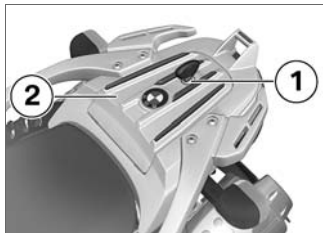

- Use the ignition key to turn stowage-compartment lock **1** clockwise.
- Remove cover **2**.



- Pull release lever **3** up while pushing down on the seat at the rear.
- Raise the seat at the rear and release the release lever.
- Remove the seat and place it, upholstered side down, on a clean surface.

Installing seat

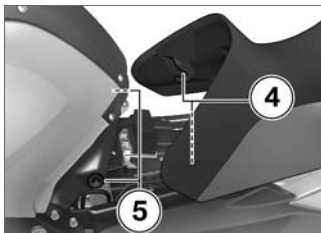

- Engage mounts **4** of the seat in holders **5** on left and right.
- Lower the seat into position and push it forward as far as it will go.
- Firmly press down on the seat at the rear.
 - » The seat engages with an audible click.

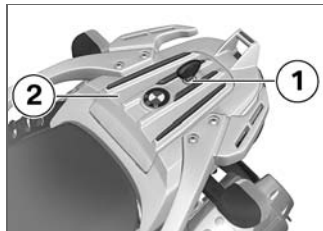

- Install cover **2**.
- Lock stowage-compartment lock **1** with the ignition key.

Riding

Safety instructions	42
Checklist.....	44
Starting	44
Running in	47
speed.....	48
Off-roading	48
Brakes	49
Parking your motorcycle	50
Refuelling	50
Secure the motorcycle for transport- ation	52

Safety instructions

Rider's equipment

Do not ride without the correct clothing. Always wear:

- Helmet
- Motorcycling jacket and trousers
- Gloves
- Boots

This applies even to short journeys, and to every season of the year. Your authorised BMW Motorrad dealer will be glad to advise you on the correct clothing for every purpose.

Restricted angle of heel

- with lowered suspension^{OE}

A motorcycle with lowered suspension has less ground clearance and cannot corner at angles of heel as extreme as those achievable by a counterpart motorcycle with

standard-height suspension (see the section entitled "Technical data").



Risk of accident by unexpectedly early contact with the ground.

Bear in mind that lowered suspension limits the motorcycle's angle of heel and ground clearance.◀

Test your motorcycle's angle of heel in situations that do not involve risk. When riding over kerbs and similar obstacles, bear in mind that your motorcycle's ground clearance is limited.

Lowering the motorcycle's suspension shortens suspension travel. Ride comfort might be restricted as a result. Be sure to adjust spring preload accordingly, particularly for riding two-up.

Correct loading



Overloading and imbalanced loads can adversely affect the motorcycle's handling. Do not exceed the permissible gross weight and be sure to comply with the instructions on loading.◀

- Set spring preload, damping characteristic and tyre pressures to suit total weight.
 - with Vario cases^{OA}
- Ensure that the case volumes on the left and right are equal.
- Make sure that the weight is uniformly distributed between right and left.
- Pack heavy items at the bottom and toward the inboard side.
- Note the maximum permissible payload and the speed limit for riding with cases fitted, as

stated on the label inside the case.◀

- with topcase^{OA}
- Note the maximum permissible payload and the speed limit for riding with topcase fitted, as stated on the label inside the topcase.◀
- with tank rucksack^{OA}
- Note the maximum permissible payload of the tank rucksack and the speed limit for riding with a tank rucksack on the motorcycle.



Payload of tank rucksack

– ≤5 kg



Maximum permissible speed for riding with the tank rucksack fitted to the motorcycle

– ≤130 km/h◀

Speed

If you ride at high speed, always bear in mind that various boundary conditions can adversely affect the handling of your motorcycle:

- Settings of the spring-strut and shock-absorber system
- Imbalanced load
- Loose clothing
- Insufficient tyre pressure
- Poor tyre tread
- Etc.

Risk of poisoning

Exhaust fumes contain carbon monoxide, which is colourless and odourless but highly toxic.



Inhaling the exhaust fumes therefore represents a health hazard and can even cause loss of consciousness with fatal consequences.
Do not inhale exhaust fumes.

Do not run the engine in an enclosed space.◀

Catalytic converter

If misfiring causes unburned fuel to enter the catalytic converter, there is a danger of overheating and damage.

For this reason, observe the following points:

- Do not run the fuel tank dry.
- Do not attempt to start or run the engine with a spark-plug cap disconnected.
- Stop the engine immediately if it misfires.
- Use only unleaded fuel.
- Comply with all specified maintenance intervals.



Unburned fuel will destroy the catalytic converter.
Note the points listed for protection of the catalytic converter.◀

Risk of overheating



inadequate if the engine were allowed to idle for a lengthy period with the motorcycle at a standstill: overheating would result. In extreme cases, the motorcycle could catch fire.

Do not allow the engine to idle unnecessarily. Ride away immediately after starting the engine. ◀

Tampering



Tampering with motorcycle settings (e.g. electronic engine management unit, throttle valves, clutch) can cause damages to the components in question and lead to failure of safety-relevant functions. Damage caused in this way is not covered by the warranty.

Do not tamper with the motorcycle in any way that could result in tuned performance. ◀

Checklist

Use the following checklist to check important functions, settings and wear limits before you ride off.

- Brakes
- Brake-fluid levels, front and rear
- Clutch
- Shock absorber setting and spring preload
- Tyre-tread depth and tyre pressures
- Cases correctly installed and luggage secured

At regular intervals:

- Engine oil level (every refuelling stop)
- Brake-pad wear (every third refuelling stop)
- Tension and lubrication of the drive chain

Starting

Side stand

You cannot start the motorcycle with the side stand extended and a gear engaged. The engine will switch itself off if you start it with the gearbox in neutral and then engage a gear before retracting the side stand.

Gearbox

You can start the engine when the gearbox is in neutral or if you pull the clutch with a gear engaged.

Starting engine



- Kill switch **1** in run position.

 Gearbox lubrication is ensured only when the engine is running. Inadequate lubrication can result in damage to the gearbox.

Do not allow the motorcycle to roll for a lengthy period of time or push it a long distance with the engine switched off. ◀

- Switch on the ignition.
 - » Pre-ride check is performed. (➡ 46)

- with BMW Motorrad ABS^{OE}
 - » ABS self-diagnosis is performed. (➡ 46)
 - Wait until the warning light for the coolant temperature stops flashing.

 The idle actuator is positioned after you switch on the ignition. The coolant-temperature warning light flashes if the idle actuator has not correctly positioned before the pre-ride check completes. In order to avoid subsequent problems, wait for this process to complete before proceeding. ◀



- Press starter button **2**.

 If ambient temperatures are very low, you might find it necessary to open the throttle slightly when starting the engine. At ambient temperatures below 0 °C, disengage the clutch before starting the engine. ◀

 If the engine fails to start even though the starter turns, insufficient battery voltage might be causing the problem. Recharge the battery before you start the engine, or use jump leads and a donor battery to start. ◀

- » The engine starts.
- » Consult the troubleshooting chart below if the engine refuses to start. (➡ 106)

Pre-ride check

The instrument cluster runs a test of the instruments and the warning lights and telltale lights and the display when the ignition is switched on. This test is known as the "Pre-Ride-Check".

Phase 1

The warning and telltale lights are switched on, along with all the segments of the multifunction display.

Phase 2

The speedometer needle swings to the limit value on its scale and back to the initial position.

Phase 3

All lights and all the segments in the display switch off. The instrument panel goes to its normal operating mode.

If the needle did not move, if a warning light or telltale light did not show as specified above or if a segment or segments of the multifunction display failed to light up:

 Some malfunctions cannot be indicated if one of the warning lights fails to show. Make sure that all the warning and telltale lights come on in the pre-ride check. ◀

- Have the fault rectified as quickly as possible by a specialist workshop, preferably an authorised BMW Motorrad dealer.

ABS self-diagnosis

– with BMW Motorrad ABS^{OE}

BMW Motorrad ABS performs self-diagnosis to ensure its operability. Self-diagnosis is performed automatically when you switch on the ignition. The motorcycle has to move forward a few metres for the wheel sensors to be tested.

Phase 1

- » Test of the diagnosis-compatible system components with the motorcycle at a standstill.
-  ABS warning light flashes.

Phase 2

- » Test of the wheel sensors as the motorcycle pulls away from rest.

 ABS warning light flashes.

ABS self-diagnosis completed

» The ABS warning light goes out.

If an indicator showing an ABS fault appears when ABS self-diagnosis completes:

- You can continue to ride. Bear in mind that the ABS function is not available.
- Have the fault rectified as quickly as possible by a specialist workshop, preferably an authorised BMW Motorrad dealer.

Running in

The first 1000 km

- While running in the motorcycle, vary the throttle opening and engine-speed range frequently; avoid riding at constant engine rpm for prolonged periods.

- Try to do most of your riding during this initial period on twisting, fairly hilly roads, avoiding high-speed main roads and highways if possible.
- Comply with the rpm limits for running in.

 Running-in speed
– max 5000 min ⁻¹ (for the first 1000 km)

- Do not omit the first inspection after 500 - 1200 km.

Brake pads

New brake pads have to bed down before they can achieve their optimum friction levels. You can compensate for this initial reduction in braking efficiency by exerting greater pressure on the levers.



New brake pads can extend stopping distance by a significant margin. Apply the brakes in good time.◀

Tyres

New tyres have a smooth surface. This must be roughened by riding in a restrained manner at various heel angles until the tyres are run in. This running in procedure is essential if the tyres are to achieve maximum grip.



Tyres do not have their full grip when new and there is a risk of accidents at extreme angles of heel. Avoid extreme angles of heel.◀

speed

Redline warning



Redline warning **1** indicates that engine revolutions have reached the rev. counter's red segment **2**. The signal remains active until you shift up or reduce engine speed.

Off-riding

After off-riding

BMW Motorrad recommends checking the following after riding the motorcycle off-road:

Tyre pressure

 Tyre pressures reduced for off-road riding impair the motorcycle's handling characteristics on surfaced roads and can lead to accidents. Always check that the tyre pressures are correct. ◀

Brakes

 When riding on loose surfaces or muddy roads, the brakes may fail to take effect immediately because of dirt or moisture on the discs or brake pads. Apply the brakes in good time until the brakes have been cleaned. ◀

 The brake pads will wear more rapidly if you ride frequently on unsurfaced tracks or poor roads. Check the thickness of the brake

pads more frequently and replace the brake pads in good time. ◀

Spring preload and shock-absorber settings

 The off-road settings for spring preload and shock absorber damping characteristic will impair the motorcycle's handling characteristics on surfaced roads.

If you have been off-riding, remember to correct spring preload and shock-absorber damping characteristics before you return to surfaced roads. ◀

Rims

BMW Motorrad recommends checking the rims for damage after off-riding.

Air filter element

 Engine damage due to clogged air filter element. If you ride in dusty terrain check

the air filter element for clogging at shorter intervals; clean or replace as necessary. ◀

Operation in very dusty conditions (desert, steppes, or the like) necessitates the use of air filter elements specially designed for conditions of this nature.

Brakes

How can stopping distance be minimised?

Load distribution shifts dynamically between the front and rear wheels when the motorcycle brakes. The sharper the motorcycle decelerates, the more load is shifted to the front wheel. The higher the wheel load, the more braking force can be transmitted without the wheel locking.

To optimise stopping distance, apply the front brakes rapidly and keep on increasing the force you apply to the brake lever. This

makes the best possible use of the dynamic increase in load at the front wheel. Remember to pull the clutch at the same time. In the "panic braking situations" that are trained so frequently braking force is applied as rapidly as possible and with the rider's full force applied to the brake levers; under these circumstances the dynamic shift in load distribution cannot keep pace with the increase in deceleration and the tyres cannot transmit the full braking force to the surface of the road. Under these circumstances the front wheel can lock up.

BMW Motorrad ABS prevents the front wheel from locking up.

Descending mountain passes



There is a danger of the brakes fading if you use only the rear brakes when descending mountain passes. Under extreme conditions, the brakes could overheat and suffer severe damage.

Use both front and rear brakes, and make use of the engine's braking effect as well. ◀

Wet and dirty brakes

Wetness and dirt on the brake discs and the brake pads diminish braking efficiency.

Delayed braking action or poor braking efficiency must be reckoned with in the following situations:

- Riding in the rain or through puddles of water.
- After the motorcycle has been washed.

- Riding on salted or gritted roads.
- After work has been carried on the brakes, due to traces of oil or grease.
- Riding on dirt-covered surfaces or off-road.

 Wetness and dirt result in poor braking efficiency. Apply the brakes lightly while riding to remove wetness and dirt, or dismount and clean the brakes.

Think ahead and brake in good time until full braking efficiency is restored.◀

Parking your motorcycle

Side stand

- Switch off the engine.

 If the ground is soft or uneven, there is no guaran-

tee that the motorcycle will rest firmly on the stand.

Always check that the ground under the stand is level and firm.◀

- Extend the side stand and prop the motorcycle on the stand.

 The side stand is designed to support only the weight of the motorcycle.

Do not lean or sit on the motorcycle with the side stand extended.◀

- If the camber of the roadway permits, turn the handlebars all the way to the left.
- On a gradient, the motorcycle should always face uphill; select 1st gear.

Centre stand

- with centre stand^{OE}

- Switch off the engine.

 If the ground is soft or uneven, there is no guarantee that the motorcycle will rest firmly on the stand.

Always check that the ground under the stand is level and firm.◀

 Excessive movements could cause the centre stand to retract, and the motorcycle would topple in consequence.

Do not lean or sit on the motorcycle with the centre stand extended.◀

- Extend the centre stand and lift the motorcycle onto the stand.

Refuelling

 Fuel is highly flammable. A naked flame close to the fuel tank can cause a fire or explosion.

Do not smoke. Never bring a naked flame near the fuel tank.◀

 Fuel expands when hot. Fuel escaping from an overfilled tank could make its way onto the road surface. This could cause a fall.

Do not overfill the fuel tank.◀

 Fuel attacks plastics, which become dull or unsightly. Wipe off plastic parts immediately if they come into contact with fuel.◀

 Leaded fuel will destroy the catalytic converter.

Use only unleaded fuel.◀

- Make sure the ground is level and firm and place the motorcycle on its side stand.

 The volume of the tank can be utilised to the full only when the motorcycle is propped on its side stand.◀

- Open the protective cap.

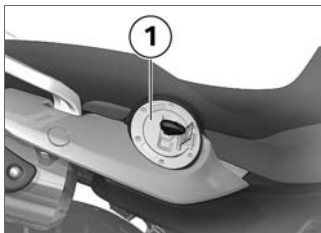

- Use the ignition key to unlock fuel filler cap **1** and pop the cap open.



- Refuel with fuel of the grade stated below; do not fill the

tank past the bottom edge of the filler neck.

 When refuelling after running on reserve, make sure that you top up the tank to a level above reserve, as otherwise the sensor will not be able to register the new level. If the sensor cannot register the new level neither the fuel-level reading nor the range readout can be updated.◀

 Recommended fuel grade

- Regular, unleaded
- 91 ROZ/RON
- 87 AKI

 Usable fuel capacity

- approx. 14 l



Reserve fuel

– approx. 4 l

- Press the fuel tank cap down firmly to close.
- » Remove the key and close the protective cap.

Secure the motorcycle for transportation

- Make sure that all components that might come into contact with straps used to secure the motorcycle are adequately protected against scratching. Use adhesive tape or soft cloths, for example, for this purpose.



The motorcycle can topple and fall on its side.

Make sure that the motorcycle cannot topple sideways.◀

- Push the motorcycle onto the transportation flat and hold it in position: do not place it on the side stand or centre stand.

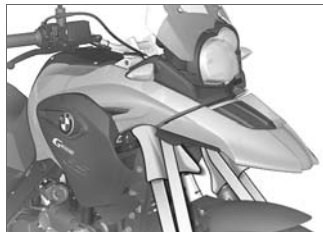

Risk of damaging components.

Take care not to trap components such as brake lines or wires.◀

- At the front, secure the straps to the bottom fork bridge on both sides.

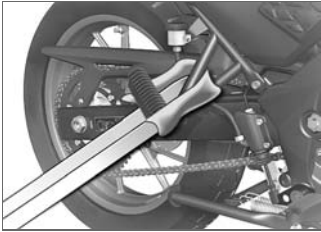

- At the rear, secure the straps to the rear footrests on both sides and tighten the straps.
- Tighten all the straps uniformly; the motorcycle's suspension should be compressed as tightly as possible front and rear.

Engineering details

Brake system with BMW Motorrad

ABS 56

Brake system with BMW Motorrad ABS

How does ABS work?

The amount of braking force that can be transferred to the road depends on factors that include the coefficient of friction of the road surface. Loose stones, ice and snow or a wet road all have much lower coefficients of friction than a clean, dry asphalt surface. The lower the coefficient of friction, the longer the braking distance.

If the rider increases braking pressure to the extent that braking force exceeds the maximum transferrable limit, the wheels start to lock and the motorcycle loses its directional stability; a fall is imminent. Before this situation can occur, ABS intervenes and adapts braking pressure to the maximum transferrable braking force, so the wheels continue

to turn and directional stability is maintained irrespective of the condition of the road surface.

What are the effects of surface irregularities?

Humps and surface irregularities can cause the wheels to lose contact temporarily with the road surface; if this happens the braking force that can be transmitted to the road can drop to zero. If the brakes are applied under these circumstances the ABS has to reduce braking force to ensure that directional stability is maintained when the wheels regain contact with the road surface. At this instant the BMW Motorrad ABS must assume an extremely low coefficient of friction, so that the wheels will continue to rotate under all imaginable circumstances, because this is the precondition for ensuring directional stability. As soon as

is registers the actual circumstances, the system reacts instantly and adjusts braking force accordingly to achieve optimum braking.

Rear wheel lift

Even under severe braking, a high level of tyre grip can mean that the front wheel does not lock up until very late, if at all. Consequently, ABS does not intervene until very late, if at all. Under these circumstances the rear wheel can lift off the ground, and the outcome can be a high-siding situation in which the motorcycle can flip over.



Severe braking can cause the rear wheel to lift off the ground.

When you brake, bear in mind that ABS control cannot be relied on in all circumstances to prevent the rear wheel from lifting clear of the ground. ◀

What is the design baseline for BMW Motorrad ABS?

Within the limits imposed by physics, BMW Motorrad ABS ensures directional stability on any surface. The system is not optimised for special requirements that apply under extreme competitive situations off-road or on the track.

Special situations

The speeds of the front and rear wheels are compared as one means of detecting a wheel's incipient tendency to lock. If the system registers implausible values for a lengthy period the ABS function is deactivated for safety reasons and an ABS fault message is issued. Self-diagnosis has to complete before fault messages can be issued.

In addition to problems with the BMW Motorrad ABS, exceptional

riding conditions can lead to a fault message being issued.

Exceptional riding conditions:

- Riding for a lengthy period with the front wheel lifted off the ground (wheelie).
- Rear wheel rotating with the motorcycle held stationary by applying the front brake (burn-out).
- Heating up with the motorcycle on the centre stand or an auxiliary stand, engine idling or with a gear engaged.
- Rear wheel locked for a lengthy period, for example while descending off-road.

If a fault message is issued on account of exceptional riding conditions as outlined above, you can reactivate the ABS function by switching the ignition off and on again.

What significance devolves on regular maintenance?



Invariably, a technical system cannot perform beyond the abilities dictated by its level of maintenance.

In order to ensure that the BMW Motorrad ABS is always maintained in optimum condition, it is essential for you to comply strictly with the specified inspection intervals. ◀

Reserves for safety

The potentially shorter braking distances which BMW Motorrad ABS permits must not be used as an excuse for careless riding. ABS is primarily a means of ensuring a safety margin in genuine emergencies.

Take care when cornering. When you apply the brakes on a corner, the motorcycle's weight and

momentum take over and even BMW Motorrad ABS is unable to counteract their effects.

Accessories

General instructions.....	60
Power sockets	60
Case	61
Topcase	63

General instructions

BMW Motorrad recommends the use of parts and accessories for your motorcycle that are approved by BMW for this purpose. Genuine BMW parts and accessories and other products which BMW has approved can be obtained from your authorised BMW Motorrad dealer, together with expert advice on their installation and use.

These parts and products have been tested by BMW for safety, function and suitability. BMW accepts product liability for them. Conversely, BMW is unable to accept any liability whatsoever for parts and accessories which it has not approved.

Also bear in mind the information on the effect of wheel size on suspension-control systems (➡ 78).



BMW Motorrad cannot examine or test each product of outside origin to ensure that it can be used on or in connection with BMW motorcycles without constituting a safety hazard. Country-specific official authorisation does not suffice as assurance. Tests conducted by these instances cannot make provision for all operating conditions experienced by BMW motorcycles and, consequently, they are not sufficient in some circumstances. Use only parts and accessories approved by BMW for your motorcycle. ◀

Whenever you are planning modifications, comply with all the legal requirements. Make sure that the motorcycle does not infringe the national road-vehicle construction and use regulations applicable in your country.

Power sockets

Notes on use of power sockets:

Ratings

Do not attempt to connect a load that would exceed the maximum amperage stated in the technical data for the on-board sockets.

Operating electrical accessories

Electrically powered accessories inevitably place a strain on the battery. It is essential to ensure that the battery retains its ability to start the engine.

Cable routing

The cables from the power sockets to the auxiliary devices must be routed in such a way that they:

- Do not impede the rider
- Do not restrict the steering angle or obstruct handling
- Cannot be trapped

Case

– with Vario cases^{OA}

Opening cases



- Turn key **1** in the case lock to right angles with the forward direction of travel.
- Press and hold down yellow latch **2** and pull up carry handle **3**.



- Push yellow button **4** down and at the same time pull the lid of the case out.



- Close the case lid.
» The lid engages with an audible click.

Closing cases

- Turn the lock with the key until it is at right angles to the forward direction of travel.

 Closing the carry handle while the case lock is in line with the forward direction of travel can result in damage to the locking tongue.

Make sure that the case lock is at right angles to the forward direction of travel when you close the carry handle. ◀

- Push carry handle **3** down.
- Turn the key in the case lock in line with the forward direc-

tion of travel and remove the key from the lock.

Adjusting case volume

- Open the case and remove all its contents.

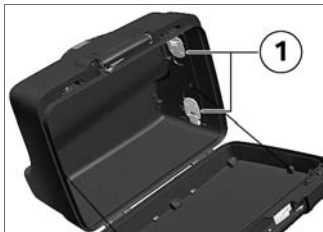

- Disengage latching levers **1** on left and right and open them.
- Adjust the case to the desired volume by sliding the outer casing of the case all the way in or out.

▶ The latching levers cannot be closed unless the outer casing of the case is set to one or other of the two limit stops.◀

- Close and engage latching levers **1** on left and right.
- Close the case.

Remove the cases



- Turn key **1** in the case lock to right angles with the forward direction of travel.
- Press and hold down yellow latch **2** and pull up carry handle **3**.



- Pull red release lever **4** up.
» Latching flap **5** pops up.
- Fully open the latching flap.
- Take a firm grip of the handle and lift the case out of the holder.

Installing cases



- Fully open latching flap **5**, if necessary pulling up red release lever **4**.



- Hook the case into case carrier **6**.

- Turn the case toward the motorcycle, pushing the mount on the case all the way onto mushroom head **7**.



- Push latching flap **5** down as far as it will go and hold it in this position.
- Push red release lever **4** down.
» The latching flap engages.
- Close the carry handle.
- Turn the key parallel with the direction of travel and remove.

Topcase

– with topcase^{OA}

Opening topcase

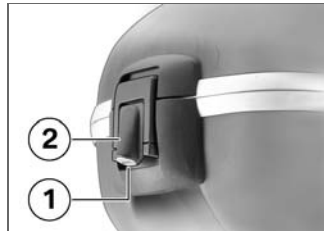

- If applicable, unlock topcase lock **1**.
- Pull up locking lever **2** and open the topcase lid.

Close the topcase

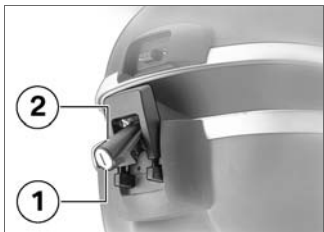

- Close the lid of the topcase and hold it down.
- Push locking lever **2** fully down.
- If applicable, lock topcase lock **1**.

Removing topcase

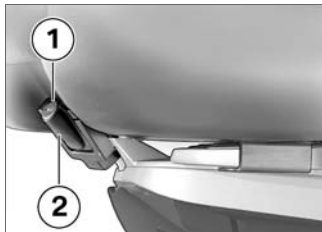

- If applicable, unlock topcase lock **1**.
- Push locking lever **2** down.
- Pull the topcase back and clear of the luggage carrier.

Installing topcase

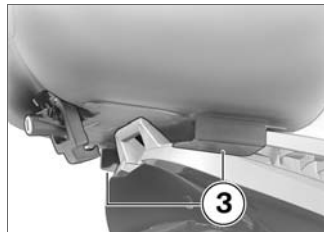

- Push the topcase with guides **3** forward onto the adapter plate until seated.

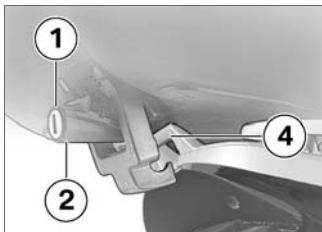

- Push locking lever **2** up, making sure that the lever engages the adapter plate at position **4**.
 - » The locking lever engages with an audible click.
- If applicable, lock topcase lock **1**.

Maintenance

Notes	68	Battery	95
Toolkit	68	Body panels	98
Engine oil	68		
Brake system	70		
Coolant	74		
Clutch	75		
Rims and tyres	76		
Chain	76		
Wheels	78		
BMW Motorrad front-wheel stand	84		
Fuses	86		
Bulbs	86		
Air filter	92		
Jump starting	94		

Notes

The "Maintenance" chapter describes straightforward procedures for checking and replacing certain wear parts.

Special tightening torques are listed as applicable. The tightening torques for the threaded fasteners on your motorcycle are listed in the section entitled "Technical data".

You will find information on more extensive maintenance and repair work in the Repair Manual on DVD for your motorcycle, which is available from your authorised BMW Motorrad dealer.

Some of the work calls for special tools and a thorough knowledge of motorcycle technology. If you are in doubt consult a specialist workshop, preferably your authorised BMW Motorrad dealer.

Toolkit

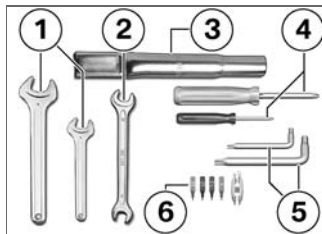

- 1** Open-ended spanner
Width across flats 24
Open-ended spanner
Width across flats 15
- 2** Open-ended spanner
Width across flats 14/19
- 3** Spark plug wrench
- 4** Reversible-blade screwdriver with star-head and plain tips
Small screwdriver with star-head tip
- 5** Torx bit, T25
Torx wrench, T45

- 6** Spare fuses with puller tool
Minifuses, 4 A, 7.5 A, 10 A and 15 A

Engine oil

Checking engine oil level

! The engine can seize if the oil level is low, and this can lead to accidents.

Always make sure that the oil level is correct. ◀

- Wipe the area around the oil filler neck clean.
- Make sure the engine is at operating temperature and hold the motorcycle upright.
– with centre stand^{OE}
- Check that the engine is at operating temperature, make sure the ground is level and firm and place the motorcycle on its centre stand. ◀
- Allow the engine to idle until the fan starts up, then allow the

engine to idle for another three minutes.

- Switch off the engine.

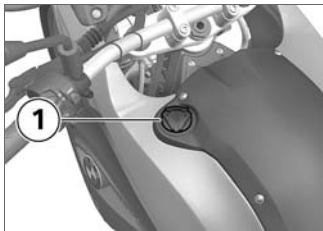

- Remove oil dipstick **1**.

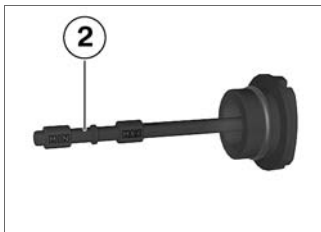

- Wipe the oil off MIN-MAX part of dipstick **2** with a clean, dry cloth.
- Seat the oil dipstick on the oil filler neck, but do not engage the threads.
- Remove the oil dipstick and check the oil level.

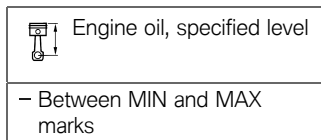
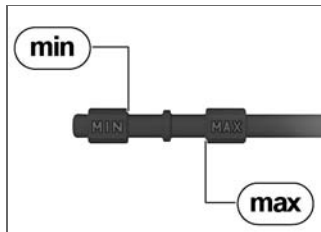

If the oil level is below the MIN mark:

- Top up the engine oil (➡ 70).

If the oil level is above the MAX mark:

- Have the oil level corrected by a specialist workshop, preferably an authorised BMW Motorrad dealer.

Top up the engine oil

- Make sure the ground is level and firm and place the motorcycle on its stand.
- Wipe the area around the filler neck clean.

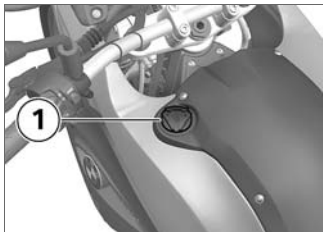

- Remove oil dipstick **1**.

! Damage to the engine can result if it is operated without enough oil, but the same also applies if the oil level is too high.

Always make sure that the oil level is correct. ◀

- Top up the engine oil to the specified level.
- Checking engine oil level (▶▶ 68).
- Install the oil dipstick.

Brake system

Check operation of the brakes

- Pull the handbrake lever.
 - » The pressure point must be clearly perceptible.
- Press the footbrake lever.
 - » The pressure point must be clearly perceptible.

If pressure points are not clearly perceptible:

! Incorrect working practices endanger the reliability of the brakes.

Have all work on the brake system undertaken by trained and qualified specialists. ◀

- Have the brakes checked by a specialist workshop, preferably

an authorised BMW Motorrad dealer.

Check the front brake pad thickness

- Make sure the ground is level and firm and place the motorcycle on its stand.



- Visually inspect the brake pads to ascertain their thickness. Viewing direction: Between wheel and front suspension toward the brake pads.



 Brake-pad wear limit, front

- min 1.0 mm (Friction pad only, without backing plate. The wear indicators (grooves) must be clearly visible.)

If the wear indicating marks are no longer clearly visible:

 Brake pads worn past the minimum permissible thickness can cause a reduction in braking efficiency and under certain circumstances they can

cause damage to the brake system.

In order to ensure the dependability of the brake system, do not permit the brake pads to wear past the minimum permissible thickness. ◀

- Have the brake pads replaced by a specialist workshop, preferably an authorised BMW Motorrad dealer.

Checking rear brake pad thickness

- Make sure the ground is level and firm and place the motorcycle on its stand.

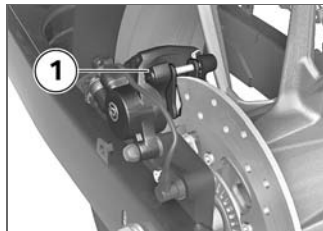

- Visually inspect the brake pads to ascertain their thickness. Viewing direction: from the rear toward brake caliper **1**.

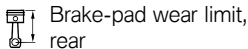
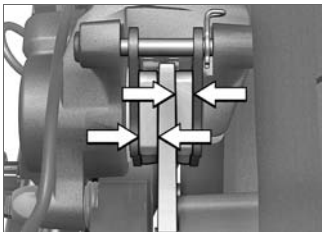

– min 1.0 mm (Friction pad only, without backing plate.)

If the wear indicating mark is no longer visible:

! Brake pads worn past the minimum permissible thickness can cause a reduction in braking efficiency and under certain circumstances they can cause damage to the brake system.

In order to ensure the dependab-

ility of the brake system, do not permit the brake pads to wear past the minimum permissible thickness.◀

- Have the brake pads replaced by a specialist workshop, preferably an authorised BMW Motorrad dealer.

Check the brake-fluid level, front brakes

! A low fluid level in the brake reservoir can allow air to penetrate the brake system. This significantly reduces braking efficiency.

Check the brake-fluid level at regular intervals.◀

- Make sure the ground is level and firm and hold the motorcycle upright.
 - with centre stand^{OE}
- Make sure the ground is level and firm and place the motorcycle on its centre stand.◀

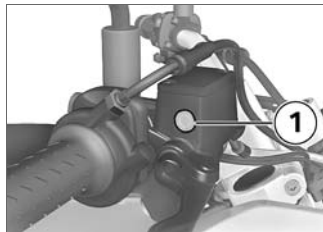

- Check the brake fluid level in front reservoir **1**.

▷ Wear of the brake pads causes the brake fluid level in the reservoir to sink.◀

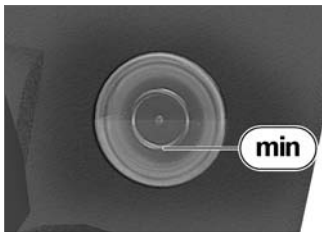

Brake fluid level, front

– DOT4 brake fluid

– It is impermissible for the brake fluid level to drop below the MIN mark. (Brake-fluid reservoir horizontal)

If the brake fluid level drops below the permitted level:

- Have the defect rectified as quickly as possible by a specialist workshop, preferably an authorised BMW Motorrad dealer.

Check the brake-fluid level, rear brakes

! A low fluid level in the brake reservoir can allow air to penetrate the brake system. This significantly reduces braking efficiency.

Check the brake-fluid level at regular intervals. ◀

- Make sure the ground is level and firm and hold the motorcycle upright.
 - with centre stand^{OE}
- Make sure the ground is level and firm and place the motorcycle on its centre stand. ◀

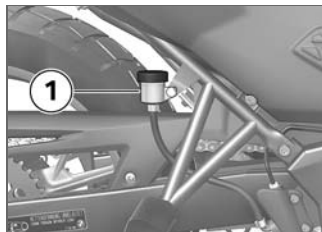

- Check the brake fluid level in rear reservoir **1**.

▷ Wear of the brake pads causes the brake fluid level in the reservoir to sink. ◀



Brake fluid level, rear

– DOT4 brake fluid

– It is impermissible for the brake fluid level to drop below the MIN mark. (Brake-fluid reservoir horizontal)

If the brake fluid level drops below the permitted level:

- Have the defect rectified as quickly as possible by a specialist workshop, preferably an authorised BMW Motorrad dealer.

Coolant

Check the coolant level

- Make sure the ground is level and firm and place the motorcycle on its stand.



! Risk of burn injuries due to contact with hot engine components.

Keep clear of all hot engine components.

Do not touch hot engine components. ◀

- Check the coolant level in the expansion tank through slit provided by GS logo **1**.

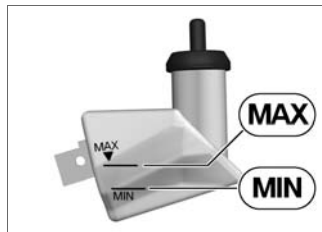

Coolant, specified level

– between MIN and MAX marks on the expansion tank

If the coolant drops below the permitted level:

- Top up the coolant.

Topping up coolant

- Removing left side panel (► 99).



- Open cap **1** of the coolant expansion tank and top up the coolant to the specified level.
- Check the coolant level (➔ 74).
- Close the cap of the coolant expansion tank.
- Installing left side panel (➔ 100).

Clutch

Checking clutch-lever play

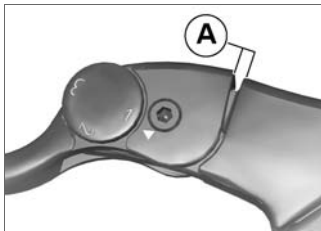

- Pull the clutch lever until resistance is perceptible.
- Measure clutch-lever play **A**.

	Clutch, play at handlebar lever
– 1.0...2.0 mm	

Clutch-lever play is out of tolerance:

- Adjusting clutch-lever play (➔ 75).

Adjusting clutch-lever play

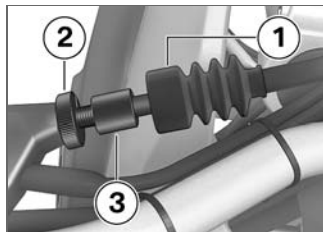

- Push back boot **1**.
- Slacken nut **2**.
- To increase clutch play: turn adjusting screw **3** clockwise.
- To reduce clutch play: turn adjusting screw **3** counter-clockwise.
- Checking clutch-lever play (➔ 75).
- Repeat the steps in this procedure until clutch play is set correctly.
- Tighten nut **2**.

- Pull boot **1** back over the adjusting screw.

Rims and tyres

Checking rims

- Make sure the ground is level and firm and place the motorcycle on its stand.
- Visually inspect the rims for defects.
- Have damaged rims checked and, if necessary, replaced by a specialist workshop, preferably an authorised BMW Motorrad dealer.

Check the tyre tread depth

 Your motorcycle's handling and grip can be impaired even before the tyres wear to the minimum tyre tread depth permitted by law.

Have the tyres changed in good time before they wear to the

minimum permissible tread depth. ◀

- Make sure the ground is level and firm and place the motorcycle on its stand.
- Measure the tyre tread depth in the main tread grooves with wear marks.

 Tyres have wear indicators integrated into the main tread grooves. The tyre is worn out when the tyre tread has worn down to the level of the marks. The locations of the marks are indicated on the edge of the tyre, e.g. by the letters TI, TWI or by an arrow. ◀

If the tyre tread is worn to minimum:

- Replace tyre or tyres, as applicable.

Chain

Lubricating chain

 Dirt, dust and inadequate lubrication will result in accelerated wear and significantly shorten the drive chain's useful life.

Clean and lubricate the drive chain at regular intervals. ◀

- Lubricate the drive chain every 1000 km at the latest. Lubricate the chain more frequently if the motorcycle is ridden in wet, dusty or dirty conditions. ◀
- Switch the ignition off and select neutral.
- Clean the drive chain with a suitable cleaning product, dry it and apply chain lubricant.
- Wipe off excess lubricant.

Checking chain sag

- Make sure the ground is level and firm and place the motorcycle on its stand.
- Turn the rear wheel until it reaches the position with the lowest amount of chain sag.

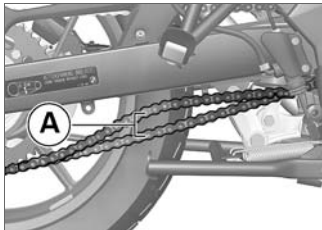

- Use a screwdriver to push the chain up and down and measure difference **A**.



Chain deflection

– 35...45 mm (Motorcycle with no weight applied, supported on its centre stand)

If measured value is outside permitted tolerance:

- Adjusting chain sag (→ 77).

Adjusting chain sag

- Make sure the ground is level and firm and place the motorcycle on its stand.

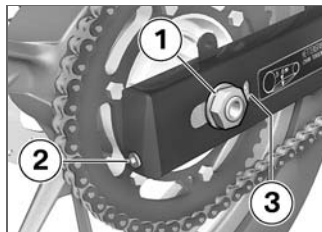

- Slacken quick-release axle nut **1**, counter-holding at the left-hand side if necessary.
- Use adjusting screws **2** on left and right to adjust chain sag.
- Checking chain sag (→ 77).
- Make sure that scale readings **3** are the same on left and right.
- Tighten quick-release axle nut **1** to the specified torque, counter-holding at the left-hand side if necessary.



Nut on quick-release axle
(rear wheel)

– 100 Nm

Checking chain wear

- Make sure the ground is level and firm and place the motorcycle on its stand.

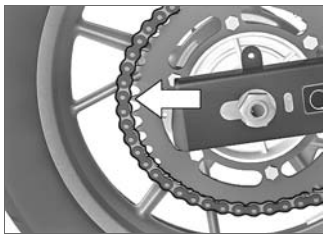

Accelerated wear.
If a component of the sprocket with mounting parts is found to be worn, the entire set has to be replaced. ◀

- Pull the chain back at the rear-most point of the sprocket.
- » The tips of the sprocket teeth must remain inside the chain links.

If the chain can be pulled back far enough to expose the tips of the sprocket teeth:

- Consult a specialist workshop, preferably an authorised BMW Motorrad dealer.

Wheels

Tyre recommendation

For each size of tyre BMW Motorrad tests and classifies as roadworthy certain makes. BMW Motorrad cannot assess the suitability or provide any guarantee of road safety for other tyres.

BMW Motorrad recommends using only tyres tested by BMW Motorrad.

You can obtain detailed information from your authorised BMW

Motorrad dealer or on the Internet at www.bmw-motorrad.com.

Effect of wheel size on suspension-control systems

Wheel size is very important as a parameter for the ABS. In particular, the diameter and the width of a motorcycle's wheels are programmed into the control unit and are fundamental to all calculations. Any change in these influencing variables, caused for example by a switch to wheels other than those installed ex-works, can have serious effects on the performance of the system.

The sensor rings are essential for correct road-speed calculation, and they too must match the motorcycle's system and consequently cannot be changed. If you decide that you would like to fit non-standard wheels to

your motorcycle, it is very important to consult a specialist workshop beforehand, preferably an authorised BMW Motorrad dealer. In some cases, the data programmed into the control unit can be changed to suit the new wheel sizes.

Removing front wheel

- Make sure the ground is level and firm and place the motorcycle on a suitable auxiliary stand.

– with centre stand^{OE}

- Make sure the ground is level and firm and place the motorcycle on its centre stand.<

– with BMW Motorrad ABS^{OE}

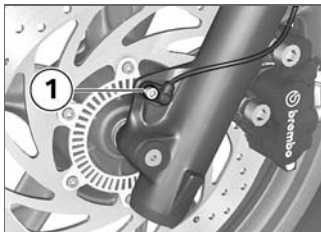

- Remove screw **1** and remove the ABS sensor from its bore. Note whether a washer is installed.<
- Raise front of motorcycle until the front wheel can turn freely. BMW Motorrad recommends the BMW Motorrad front-wheel stand for lifting the motorcycle.
- Install the front-wheel stand (➔ 84).

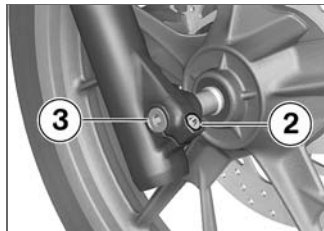

- Release axle clamping screw **2**.
- Remove axle **3**, while supporting the wheel.
- Do not remove the grease from the axle.

– with BMW Motorrad ABS^{OE}

- When rolling the front wheel clear of the motorcycle, take care not to damage the ABS sensor and the ABS line.<
- Roll the front wheel forward to remove.



- Remove spacing bushings **4** and **5** from the wheel hub.

Installing front wheel

 Threaded fasteners not tightened to the specified torque can work loose or their threads can suffer damage.

Always have the security of the fasteners checked by a specialist workshop, preferably an authorised BMW Motorrad dealer. ◀



- Slip spacing bushings **5** and **4** onto the wheel hub.

– with BMW Motorrad ABS^{OE}

- When installing the front wheel, take care not to damage the ABS sensor and the ABS line. ◀

 The front wheel must be installed right way round to rotate in the correct direction. Note the direction-of-rotation arrows on the tyre or the wheel rim. ◀

- Roll the front wheel into position between the forks, making

sure that the brake disc passes between the brake pads.

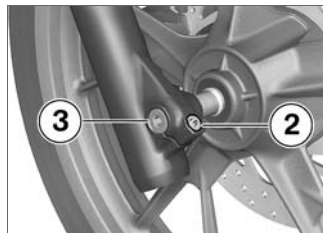

- Raise the front wheel, insert axle **3** and tighten to specified torque.



Quick-release axle in telescopic forks

– 45 Nm

- Remove the front-wheel stand.
- Apply the front brake and firmly compress the front forks several times
- Tighten axle clamping screw **2** to the specified torque.

 Clamp, front quick-release axle

– 19 Nm

– with BMW Motorrad ABS^{OE}

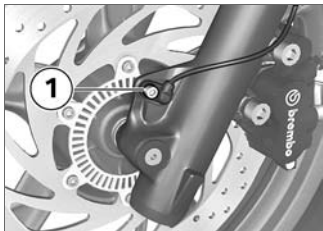

• Insert the ABS sensor into its bore and install screw **1**. If present, install the washer.◁

– without centre stand^{OE}

• Remove the auxiliary stand.◁

Removing rear wheel

• Make sure the ground is level and firm and place the motorcycle on its stand.

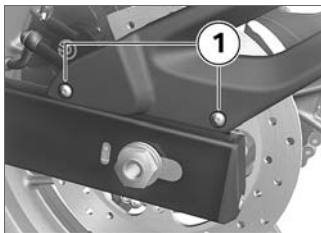

• Remove two screws **1**.

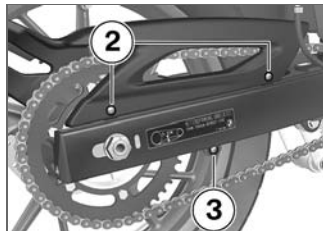

• Remove screws **2** and **3** and remove the rear-wheel cover.

• Make sure the ground is level and firm and place the motorcycle on a suitable auxiliary stand.

– with centre stand^{OE}

• Make sure the ground is level and firm and place the motorcycle on its centre stand.◁

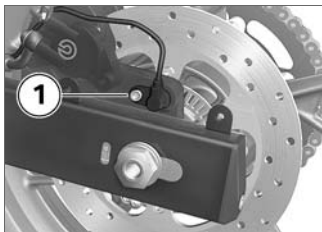

- Remove screw **1** and remove the wheel-speed sensor from its holder.

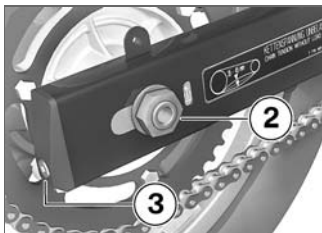

- Remove nut **2**, counter-holding at the left-hand side if necessary.

- Slacken adjusting screws **3** on left and right by turning them counter-clockwise.

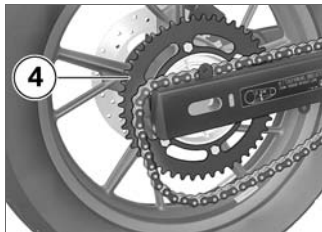

- Push the rear wheel as far forward as possible and disengage the chain from sprocket **4**.

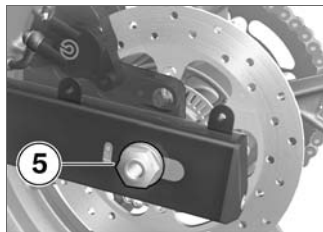

- Remove quick-release axle **5**, supporting the rear wheel as you do so.
- Roll the rear wheel back until it is clear of the swinging arm, while holding the brake caliper on the left-hand side.

▷ The sprocket and the spacer sleeves on left and right are loose fits in the wheel. Make sure that these parts are not damaged or lost on removal.◀

Install the rear wheel

 Threaded fasteners not tightened to the specified torque can work loose or their threads can suffer damage. Always have the security of the fasteners checked by a specialist workshop, preferably an authorised BMW Motorrad dealer. ◀

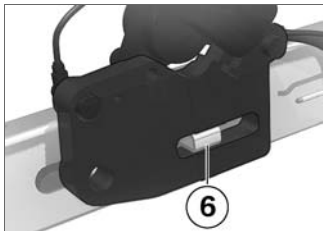

- Make sure that the brake caliper moves on guide **6**.
- Roll the rear wheel into the swinging arm, making sure that the brake disc passes between the brake pads.



- Lift the rear wheel and work quick-release axle **5** through the swinging arm, the brake caliper and the rear wheel.

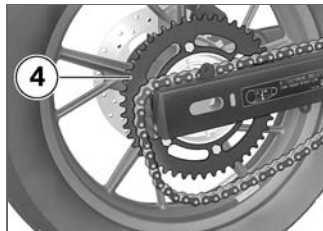

- Roll the rear wheel as far forward as possible and loop the chain over sprocket **4**.



- Install axle nut **2**, but do not tighten it at this point.

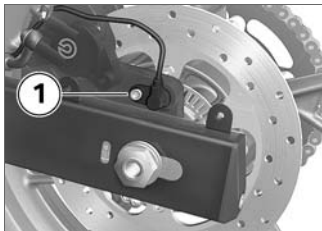

- Insert the wheel-speed sensor into the holder and install screw **1**.
 - Adjusting chain sag (➔ 77).
- without centre stand^{OE}
- Remove the auxiliary stand.<

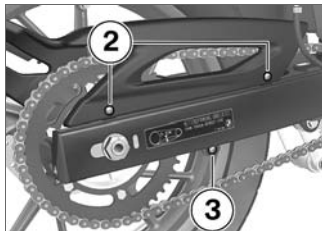

- Hold the rear-wheel cover in position and install screws **2** and **3**.

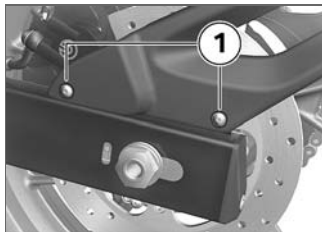

- Install two screws **1**.

BMW Motorrad front-wheel stand

Install the front-wheel stand

! The BMW Motorrad front wheel stand is not designed to support the motorcycle without the assistance of an auxiliary stand. A motorcycle resting only on the front wheel stand and the rear wheel can topple.

Place the motorcycle on an auxiliary stand before lifting the front wheel with the BMW Motorrad front-wheel stand.<

- Place the motorcycle on a suitable auxiliary stand.
 - with centre stand^{OE}
- Make sure the ground is level and firm and place the motorcycle on its centre stand.<
- Use basic stand with tool number (83 30 0 402 241) in com-

combination with front-wheel adapter (83 30 0 402 242).

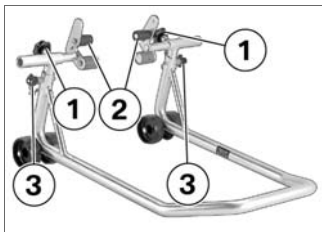

- Slacken adjusting screws **1**.
- Push the two adapters **2** apart until the front forks fit between them. Adjust the adapter studs to suit the front suspension.
- Use locating pins **3** to set the front-wheel stand to the desired height.
- Centre the front-wheel stand relative to the front wheel and push it against the front axle.

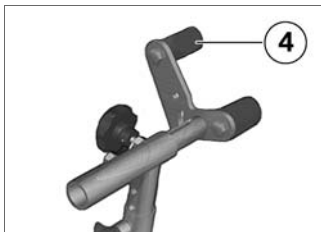

- Install rubber buffers **4** in the top positions on left and right.

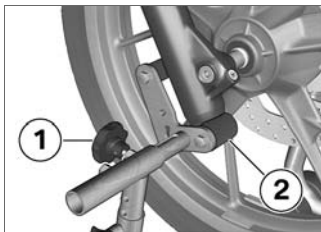

- Align the two adapters **2** so that the front forks are securely seated.
- Tighten adjusting screws **1**.

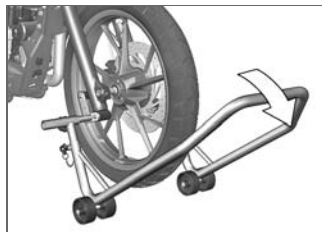

- Apply uniform pressure to push the front-wheel stand down and raise the motorcycle.

– with centre stand^{OE}

 If the motorcycle is raised too far the centre stand will lift clear of the ground and the motorcycle could topple to one side.

When raising the motorcycle, make sure that the centre stand remains on the ground. If necessary, adjust the height of the front-wheel stand. ◀

- Make sure the motorcycle is standing firmly.◀

Fuses

Removing fuse

! Risk of fire if an attempt is made to jumper defective fuse.

Always replace defective fuses with new fuses of the correct amperage rating.◀

- Switch off the ignition.
- Remove the seat (➡ 38).



- Squeeze latches **1** together and remove the fuse cover.

- Use the tool from the on-board toolkit to pull the defective fuse up and out of the fuse box.

▶ If fuse defects recur frequently have the electric circuits checked by a specialist workshop, preferably an authorised BMW Motorrad dealer.◀

Install the fuse

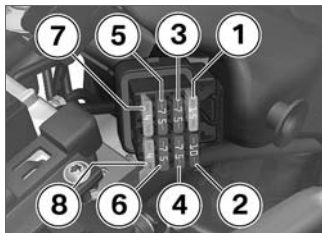

- Replace the defective fuse with a fuse of the correct amperage rating.

▶ The fuse assignments and fuse amperage ratings specified for your motorcycle are lis-

ted in the section entitled "Technical data". The figures in the graphic correspond to the fuse numbers.◀

- Close the fuse cover.
- » The latch engages with an audible click.
- Installing seat (➡ 39).

Bulbs

Notes

! A defective bulb places your safety at risk because it is easier for other users to oversee the motorcycle. Replace defective bulbs as soon as possible; always carry a complete set of spare bulbs if possible.◀

! The bulb is pressurised and can cause injury if damaged.

Wear protective goggles and gloves when changing bulbs.◀

▶ The types of bulb fitted to your motorcycle are listed in the section entitled "Technical data". ◀

▶ Do not touch the glass of new bulbs with your fingers. Use a clean, dry cloth to hold the bulbs when handling them. Dirt deposits, in particular oil and grease, interfere with heat radiation from the bulb. This leads to overheating and shortens the bulb's operating life. ◀

Replacing low-beam and high-beam headlight bulb

- Make sure the ground is level and firm and place the motorcycle on its stand.



- Remove screw **1** and work the instrument panel up out of the holders.
- Lay the instrument panel aside.
- Switch off the ignition.



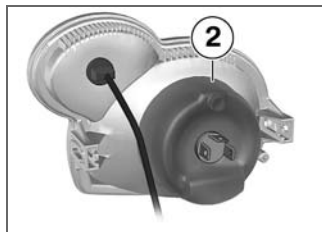

- Disconnect plug **1**, counter-holding the bulb under the rubber cap.

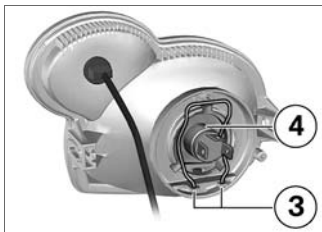

- Remove rubber cap **2**.



- Disengage spring clip **3** from the latches and swing it up.
- Remove bulb **4**.
- Replace the defective bulb.

 Bulb for low-beam and
 high-beam headlight

- H4 / 12 V / 55 W / 60 W

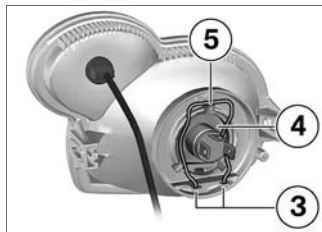

- Install bulb **4**, making sure that tab **5** is correctly positioned.
- Engage spring clip **3**.



- Install rubber cap **2**.



- Connect plug **1**.

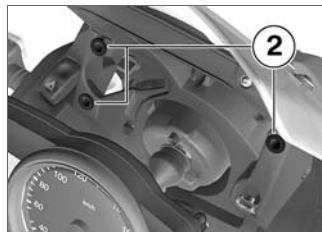

- Seat the instrument panel in holders **2**.



- Install screw **1**.

Replacing parking-light bulb

- Make sure the ground is level and firm and place the motorcycle on its stand.
- Switch off the ignition.



- Pull bulb socket **1** out of the headlight housing.



- Remove bulb from the socket.
- Replace the defective bulb.

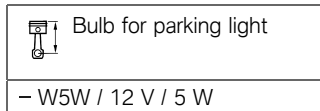

- Insert the bulb into the bulb socket.



- Insert bulb socket **1** into the headlight housing.

Replacing turn indicator bulbs, front and rear

- Make sure the ground is level and firm and place the motor-cycle on its stand.
- Switch off the ignition.



- Remove screw **1**.



- Pull the glass out of the reflector housing at the threaded-fastener side.

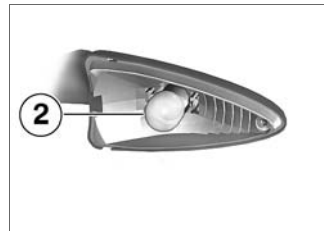

- Turn bulb **2** counter-clockwise and remove it from the bulb housing.
- Replace the defective bulb.



Bulbs for flashing turn indicators, front

– RY10W / 12 V / 10 W



Bulbs for flashing turn indicators, rear

– RY10W / 12 V / 10 W

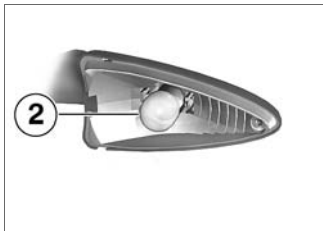

- Turn bulb **2** clockwise to install it in the bulb housing.



- Install screw **1**.

Replacing rear-light and brake-light bulb

 If it is not standing firmly, the motorcycle could topple in the course of the operations described below.

Always make sure that the motorcycle is stable and firmly supported. ◀

- Make sure the ground is level and firm and place the motorcycle on its stand.
- Switch off the ignition.



- Working from the inboard side, insert the glass into the bulb housing and close the housing.

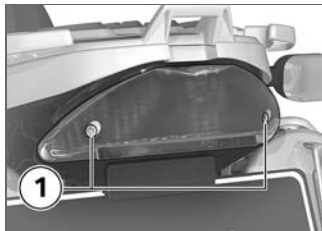

- Remove two screws **1** and remove the rear-light glass.

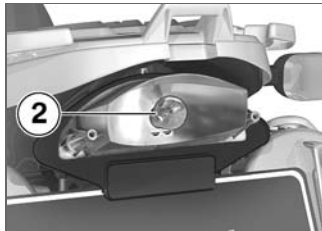

- Press bulb **2** into its socket and turn it counter-clockwise to remove.

- Replace the defective bulb.

 Bulb for tail light/brake light

– P25-2 / 12 V / 5 W / 21 W

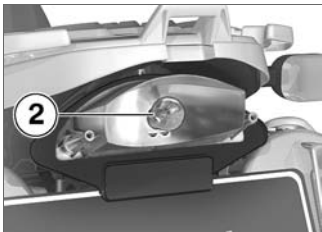

- Press bulb **2** into its socket and turn it clockwise to install.

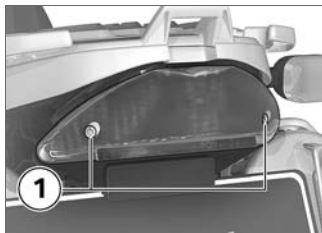

- Hold the rear-light glass in position and install two screws **1**.

Air filter

Replacing air-filter element

- Remove the right side panel ( 98).

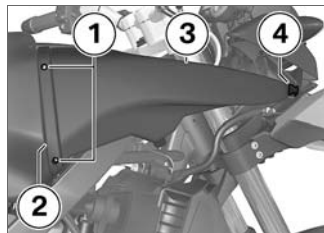

- Remove two screws **1**.
- Pull out connecting flange **2**.
- Disconnect intake air pipe **3** from the air filter housing, remove it from mount **4** and turn it aside.

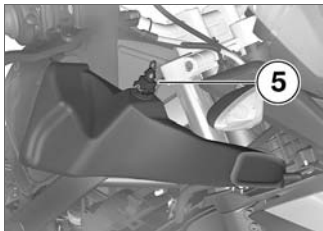

- Disconnect plug **5**.

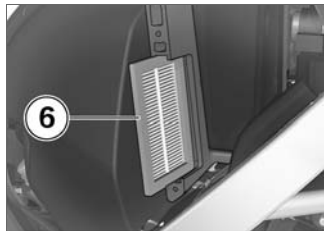

- Insert cleaned or new air filter element **6**.



- Seat the intake air pipe in mount **4**.

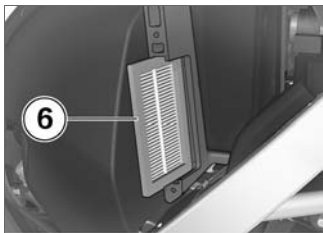

- Remove air filter element **6**.

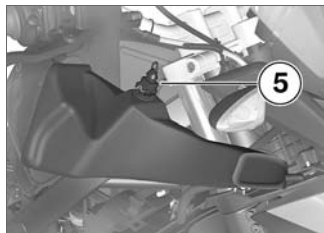

- Connect plug **5**.



- Seat the intake air pipe in guides **7** of the air filter housing. Take care not to

bend the rubber seals of the air filter element out of shape.

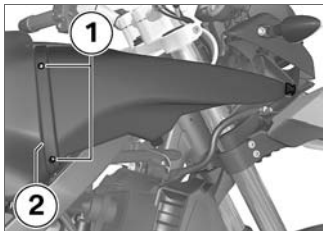

- Install connecting flange **2**.
- Install two screws **1**.
- Install the right side panel (➔ 99).

Jump starting

! The wires leading to the power socket do not have a load-capacity rating adequate for jump-starting the engine. Excessively high current can lead to a cable fire or damage to the vehicle electronics.

Do not use the on-board socket to jump-start the engine of the motorcycle. ◀

! A short-circuit can result if the crocodile clips of the jump leads are accidentally brought into contact with the motorcycle.

Use only jump leads fitted with fully insulated crocodile clips at both ends. ◀

! Jump-starting with a donor-battery voltage higher than 12 V can damage the vehicle electronics.

Make sure that the battery of the donor vehicle has a voltage rating of 12 V. ◀

- Make sure the ground is level and firm and place the motorcycle on its stand.
- Remove the seat (➔ 38).

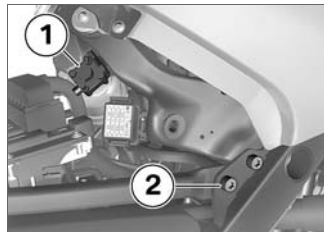

- Remove cover **1** from the battery connection point.
- Begin by connecting one end of the red jump lead to the motorcycle's battery connection point and the other end to the positive terminal of the donor vehicle's battery.
- Connect one end of the black jump lead to a suitable earthing point on the motorcycle (e.g. screw **2**) and the other end to a suitable earthing point on the donor vehicle or the negative terminal of the donor vehicle's battery.

- Run the engine of the donor vehicle during jump-starting.
- Start the engine of the vehicle with the discharged battery in the usual way; if the engine does not start, wait a few minutes before repeating the attempt in order to protect the starter motor and the donor battery.
- Allow both engines to idle for a few minutes before disconnecting the jump leads.
- Disconnect the jump lead from the negative terminal and the ground point first, then disconnect the second jump lead from the positive terminal and the battery connection point.

 Do not use proprietary start-assist sprays or other products to start the engine.◀

- Installing seat (➡ 39).

Battery

Maintenance instructions

Correct upkeep, recharging and storage will prolong the life of the battery and are essential if warranty claims are to be considered.

Compliance with the points below is important in order to maximise battery life:

- Keep the surface of the battery clean and dry
- Be sure to read and comply with the instructions for charging the battery on the following pages
- Do not turn the battery upside down

 If the battery is not disconnected, the on-board electronics (e.g. clock, etc.) gradually drain the battery. This can cause the battery to run flat. If this happens, warranty claims will not be accepted.

If the motorcycle is to be out of use for more than four weeks, disconnect the battery or connect a suitable trickle charger to the battery.◀

Charge the battery when connected

 Charging the connected battery directly at the battery terminals can damage the vehicle electronics.

Always disconnect the battery from the on-board circuits before recharging it with a charger connected directly to the battery posts.◀

 If you switch on the ignition and the multifunction display and telltale lights fail to light up, the battery is completely flat. Attempting to charge a completely flat battery via the on-board socket can cause damage to the motorcycle's electronics.

If a battery has discharged to the extent that it is completely flat, it has to be disconnected from the on-board circuits and charged with the charger connected directly to the battery posts. ◀

- With the battery connected to the motorcycle's on-board electrical system, charge only via the power socket.
- Comply with the operating instructions of the charger.

Charging battery when disconnected

- Charge the battery using a suitable charger.
- Comply with the operating instructions of the charger.
- Once the battery is fully charged, disconnect the charger's terminal clips from the battery terminals.

▶ The battery has to be recharged at regular intervals in the course of a lengthy period of disuse. See the instructions for caring for your battery. Always fully recharge the battery before restoring it to use ◀

Removing battery

- Make sure the ground is level and firm and place the motorcycle on its stand.
 - with anti-theft alarm ^{OE}
- If applicable, switch off the anti-theft alarm. ◀
- Switch off the ignition.
- Remove the centre trim panel (➔ 98).

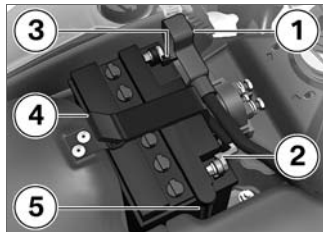

- Push back cover **1** of the battery's positive terminal.

⚠ Disconnection in the wrong sequence increases the risk of short-circuits. Always proceed in the correct sequence. ◀

- Disconnect negative lead **2** first.
- Then disconnect positive lead **3**.
- Disengage battery retaining strap **4** and disconnect breather hose **5**.

- Lift the battery up and out; work it slightly back and forth if it is difficult to remove.

Install the battery

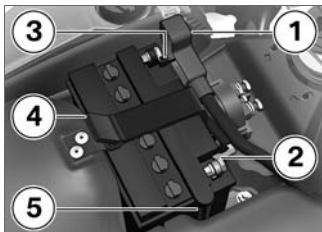

- Install the battery, making sure to connect breather hose **5**.
- Install battery retaining strap **4**.
- Connect positive lead **3** first.
- Then connect negative lead **2**.
- Push cover **1** into position over the battery positive terminal.
- Installing centre trim panel (→ 98).
- Setting clock (→ 29).

Checking battery-acid level

- Check the acid level regularly at intervals of approximately three months.
- Removing battery (→ 96).

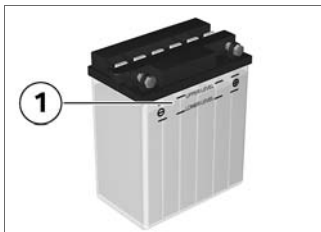

- Check the acid level at mark **1**.

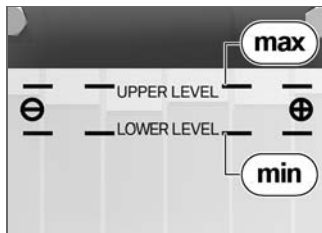

 Specified level, battery acid

– Between MIN and MAX marks

If the acid level is below the MIN mark:

- Top up the battery acid with distilled water to the specified level.

Body panels

Remove the centre trim panel

- Make sure the ground is level and firm and place the motorcycle on its stand.
- Remove the seat (➡ 38).

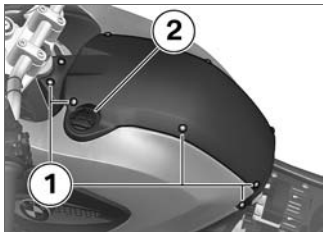

- Remove screws **1** on left and right.
- Remove oil dipstick **2** and remove the centre trim panel.
- Install the oil dipstick.

Installing centre trim panel



- Remove oil dipstick **2**.

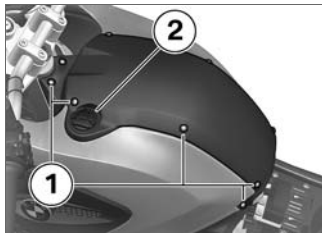

- Hold the centre trim panel in position and install oil dipstick **2**.

- Install screws **1** on left and right.
- Installing seat (➡ 39).

Remove the right side panel

- Make sure the ground is level and firm and place the motorcycle on its stand.
- Remove the centre trim panel (➡ 98).



- Remove screws **1** and **2**.



- Remove screw **3**.
- Pull the side panel at **4** out of the mount and remove.

Install the right side panel

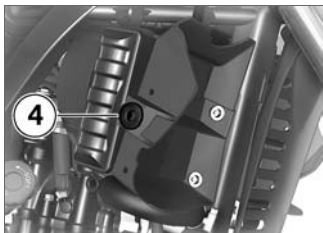

- Insert the side panel into mount **4**.



- Install short screw **3**.



- Install screws **1** and **2**.
- Installing centre trim panel (→ 98).

Removing left side panel

- Make sure the ground is level and firm and place the motorcycle on its stand.
- Remove the centre trim panel (→ 98).



- Remove screws **1** and **2**.



- Remove screw **3**.
- Pull the side panel at **4** out of the mount and remove.

Installing left side panel



- Slip the side panel behind top section of fairing **5**, then seat it in mount **4**.

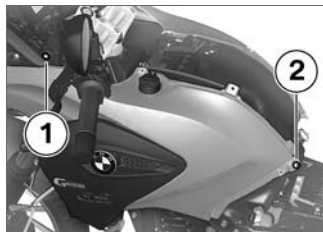

- Install screws **1** and **2**.
- Installing centre trim panel (➔ 98).



- Install screw **3**.

Care

Care products	102
Washing motorcycle	102
Cleaning easily damaged components.....	102
Paint care	103
Protective wax coating	104
Laying up motorcycle	104
Restoring motorcycle to use	104

Care products

BMW Motorrad recommends that you use the cleaning and care products you can obtain from your authorised BMW Motorrad dealer. The substances in BMW Care Products have been tested in laboratories and in practice; they provide optimised care and protection for the materials used in your vehicle.



The use of unsuitable cleaning and care products can damage vehicle components. Do not use solvents such as cellulose thinners, cold cleaners, fuel or the like, and do not use cleaning products that contain alcohol.◀

Washing motorcycle

BMW Motorrad recommends that you use BMW insect remover to soften and wash off insects and stubborn dirt on

painted parts prior to washing the motorcycle.

To prevent stains, do not wash the motorcycle immediately after it has been exposed to strong sunlight and do not wash it in the sun.

Make sure that the motorcycle is washed frequently, especially during the winter months.

To remove road salt, clean the motorcycle with cold water immediately after every trip.



After the motorcycle has been washed, ridden through water or ridden in the rain, the brake discs and pads might be wet and the brakes might not take effect immediately.

Apply the brakes in good time until the brake discs and brake pads have dried out.◀



Warm water intensifies the effect of salt.

Use only cold water to wash off road salt.◀



The high pressure of high-pressure cleaners (steam cleaners) can damage seals, the hydraulic brake system, the electrical system, and the seat.

Do not use a steam jet or high-pressure cleaning equipment.◀

Cleaning easily damaged components

Plastics

Clean plastic parts with water and BMW plastic care emulsion. This includes in particular:

- Windscreen and slipstream deflectors
- Headlight lens made of plastic
- Glass cover of the instrument cluster
- Black, unpainted parts

 If plastic parts are cleaned using unsuitable cleaning agents, the surfaces can be damaged.

Do not use cleaning agents that contain alcohol, solvents or abrasives to clean plastic parts. Even fly-remover pads or cleaning pads with hard surfaces can produce scratches.◀

 Soften stubborn dirt and insects by covering the affected areas with a wet cloth.◀

Chrome

Use plenty of water and BMW shampoo to clean chrome, particularly if it has been exposed to road salt. Use chrome polish for additional treatment.

Radiator

Clean the radiator regularly to prevent overheating of the engine due to inadequate cooling. For example, use a garden hose with low water pressure.

 Cooling fins can be bent easily.

Take care not to bend the fins when cleaning the radiator.◀

Rubber

Treat rubber components with water or BMW rubber-care products.

 Using silicone sprays for the care of rubber seals can cause damage.

Do not use silicone sprays or other care products that contain silicon.◀

Paint care

Washing the motorcycle regularly will help counteract the long-term effects of substances that damage the paint, especially if your motorcycle is ridden in areas with high air pollution or natural sources of dirt, for example tree resin or pollen.

Remove particularly aggressive substances immediately, however, as otherwise the paint can be affected or become discoloured. Substances of this nature include spilt fuel, oil, grease, brake fluid and bird droppings. We recommend BMW vehicle polish or BMW paint cleaner for this purpose.

Marks on the paintwork are particularly easy to see after the motorcycle has been washed. Remove stains of this kind immediately, using cleaning-grade benzene or petroleum spirit on a clean cloth or ball of cotton wool.

BMW Motorrad recommends BMW tar remover for removing specks of tar. Remember to wax the parts treated in this way.

Protective wax coating

BMW Motorrad recommends applying only BMW car wax or products containing carnauba wax or synthetic wax.

It is time to rewax the paintwork when water "puddles" on the surface, instead of forming beads.

Laying up motorcycle

- Clean the motorcycle.
- Removing battery (🔧 96).
- Spray the brake and clutch lever pivots, the side stand pivots and the centre stand pivots (if the motorcycle is fitted with a centre stand) with a suitable lubricant.

- Coat bright metal and chrome-plated parts with an acid-free grease (e.g. Vaseline).
- Stand the motorcycle in a dry room in such a way that there is no load on either wheel.

▶ Before laying the vehicle up out of use, have the engine oil and the oil filter element changed by a specialist workshop, preferably an authorised BMW Motorrad dealer. Combine work for laying up/restoring to use with a BMW service or inspection.◀

Restoring motorcycle to use

- Remove the protective wax coating.
- Clean the motorcycle.
- Install a charged battery.
- Before starting: work through the checklist.

Technical data

troubleshooting chart	106
Threaded fasteners	107
Engine	109
Fuel.....	110
Engine oil	110
Clutch	111
Transmission	111
Rear-wheel drive.....	112
Running gear	112
Brakes	113
Wheels and tyres	113
Electrics	114
Frame	116
Dimensions	116
Weights.....	117

Riding specifications	117
-----------------------------	-----

troubleshooting chart

Engine does not start at all or is difficult to start.

Possible cause

Rectification

Emergency off switch (kill switch)	Kill switch in operating position (run).
Side stand	Retract the side stand (➡ 44).
Gear engaged and clutch not disengaged.	Select neutral or pull the clutch lever (➡ 44).
No fuel in tank	Refuelling (➡ 50).
Battery flat	Charge the battery when connected (➡ 95).

Threaded fasteners

Front wheel	Value	Valid
Quick-release axle in telescopic forks		
M16 x 1.5	45 Nm	
Clamp, front quick-release axle		
M8 x 20	19 Nm	
Rear wheel	Value	Valid
Nut on quick-release axle (rear wheel)		
M16 x 1.5	100 Nm	
Tensioning screws for drive chain		
M8 x 70	10 Nm	
Mirror arm	Value	Valid
Locknut (mirror) to clamping piece		
M18 x 1	20 Nm	

Mirror arm	Value	Valid
Clamping piece (mirror) to clamping block		
M10 x 1.25	30 Nm	

Engine

Engine design	Single-cylinder four-stroke, double overhead camshafts driven by roller chain, 4 valves operated by bucket tappets, balancing shaft, liquid-cooled cylinder and cylinder head, integral coolant pump, 5-speed gearbox and dry sump lubrication.
Displacement	652 cm ³
Cylinder bore	100 mm
Piston stroke	83 mm
Compression ratio	11.5:1
Nominal output	35 kW, at engine speed: 6500 min ⁻¹
– with power reduction ^{OA}	25 kW, at engine speed: 6500 min ⁻¹
Torque	60 Nm, at engine speed: 5000 min ⁻¹
– with power reduction ^{OA}	47 Nm, at engine speed: 4500 min ⁻¹
Maximum engine speed	max 7500 min ⁻¹
Idle speed	1500 \pm 100 min ⁻¹

Fuel

Recommended fuel grade	Regular, unleaded 91 ROZ/RON 87 AKI
Usable fuel capacity	approx. 14 l
Reserve fuel	approx. 4 l

Engine oil

Engine oil, capacity	2.3 l, Total capacity (with filter change) 1.7 l, Oil tank - prefilling 0.6 l, Oil tank - topping up
viscosity classes recommended by BMW Motorrad	
SAE 10W-40, API SG / SH / JASO MA	≥-20 °C
SAE 15W-40, API SG / SH / JASO MA	≥-10 °C
Oil grades	BMW Motorrad recommends not using oil additives, because they can have a detrimental effect on clutch operation. BMW Motorrad recommends not using synthetic oils for the first 10000 km. Please do not hesitate to contact your authorised BMW Motorrad dealer if you have any questions relating the choice of a suitable engine oil for your motorcycle.

Clutch

clutch type	Multiplate clutch running in oil bath
-------------	---------------------------------------

Transmission

gearbox type	Claw-shift 5-speed gearbox, integrated into engine block
Gearbox transmission ratios	1.946 (72:37 teeth), Primary transmission ratio 2.750 (33:12 teeth), 1st gear 1.750 (28:16 teeth), 2nd gear 1.313 (21:16 teeth), 3rd gear 1.045 (23:22 teeth), 4th gear 0.875 (21:24 teeth), 5th gear

Rear-wheel drive

Type of final drive	Chain drive
Type of rear suspension	Box-section two-arm fork
Secondary transmission ratio	2,938

Running gear

Type of front suspension	Telescopic forks
Spring travel, front	170 mm, At wheel
– with lowered suspension ^{OE}	140 mm, At wheel
Type of rear suspension	Box-section two-arm fork
Spring travel, rear	165 mm, At wheel
– with lowered suspension ^{OE}	130 mm, At wheel

Brakes

Type of front brake	hydraulically actuated disc brake with 2-piston floating caliper
Brake-pad material, front	Sintered metal
Type of rear brake	hydraulically actuated disc brake with 1-piston floating caliper
Brake-pad material, rear	Organic material

Wheels and tyres

Recommended tyre sets	You can obtain an up-to-date list of approved tyres from your authorised BMW Motorrad dealer or on the Internet at " www.bmw-motorrad.com ".
-----------------------	--

Front wheel

front wheel type	Cast aluminium, MT H2
front wheel rim size	2.50" x 19"
Tyre designation, front	110 / 80 - 19

Rear wheel

rear-wheel type	Cast aluminium, MT H2
rear wheel rim size	3.50" x 17"
Tyre designation, rear	140 / 80 - 17

Tyre pressure

Tyre pressure, front	2.2 bar, Tyre cold
Tyre pressure, rear	2.5 bar, one-up, tyre cold 2.9 bar, two-up and with luggage, tyre cold

Electrics**Battery**

battery type	Lead-acid battery
battery rated voltage	12 V
battery rated capacity	12 Ah

Spark plugs

Spark plugs, manufacturer and designation	NGK DR 8 EB
Electrode gap of spark plug	0.6...0.7 mm, When new

Lighting

Bulb for low-beam and high-beam headlight	H4 / 12 V / 55 W / 60 W
Bulb for parking light	W5W / 12 V / 5 W
Bulb for tail light/brake light	P25-2 / 12 V / 5 W / 21 W
Bulbs for flashing turn indicators, front	RY10W / 12 V / 10 W
Bulbs for flashing turn indicators, rear	RY10W / 12 V / 10 W

Fuses

Current rating of fuse 1 (for engine electronics)	15 A
Current rating of fuse 2 (for instrument panel, hazard warning flashers, on-board socket, optional accessories and diagnosis plug)	10 A
Current rating of fuse 3 (for horn and headlight flasher)	7.5 A
Current rating of fuse 4 (for low-beam headlight)	7.5 A
Current rating of fuse 5 (for high-beam headlight)	7.5 A
Current rating of fuse 6 (for instrument panel, flashing turn indicators, hazard warning flashers, brake light and optional accessories)	7.5 A
Current rating of fuse 7 (for rear light and parking light)	4 A
Current rating of fuse 8 (for heated handlebar grips)	4 A

Frame

Frame type	Tubular sectional-steel bridge-type frame with bolt-on rear frame
type plate location	Main frame, top right
VIN location	Steering head, right

Dimensions

Length of motorcycle	2165 mm
Height of motorcycle	1390 mm, without rider at DIN unladen weight
Width of motorcycle	920 mm, Across mirrors
Front-seat height	780 mm, Without rider at unladen weight
– with lowered suspension ^{OE}	750 mm, Without rider at unladen weight
– with high seat ^{OA}	820 mm, Without rider at unladen weight
rider's inside-leg arc, heel to heel	1770 mm
– with lowered suspension ^{OE}	1710 mm
– with high seat ^{OA}	1850 mm

Weights

Unladen weight	193 kg, DIN unladen weight, ready for road, 90 % load of fuel, without optional extras
Permissible gross weight	380 kg
Maximum payload	max 188 kg

Riding specifications

Top speed	170 km/h
– with power reduction ^{OA}	145 km/h

Service

BMW Motorrad service	120
BMW Motorrad service quality	120
BMW Motorrad mobility services - roadside assistance	120
BMW Motorrad service network	121
Maintenance work	121
Confirmation of maintenance work	122
Confirmation of service	127

BMW Motorrad service

Advanced technology requires specially adapted methods of maintenance and repair.



If maintenance and repair work is performed inexpertly, it could result in consequential damage and thus constitute a safety risk.

BMW Motorrad recommends you to have all the associated work on your motorcycle carried out by a specialist workshop, preferably an authorised BMW Motorrad dealer. ◀

Your authorised BMW Motorrad dealer can provide information on BMW services and the work undertaken as part of each service. Have all maintenance and repair work carried out confirmed in the "Service" chapter in this manual. Authorised BMW Motorrad dealers are supplied with the latest technical information and have

the necessary technical know-how. BMW Motorrad recommends that you contact your authorised BMW Motorrad dealer if you have questions regarding your motorcycle.

BMW Motorrad service quality

Along with its reputation for engineering quality and high reliability, BMW Motorrad is a byword for excellent quality of service.

To ensure that your BMW is always in optimum condition, BMW Motorrad recommends that you have the maintenance work required for your motorcycle carried out regularly, preferably by your authorised BMW Motorrad dealer. For generous treatment of claims submitted after the warranty period has expired, evidence of regular maintenance is essential.

Certain signs of wear, moreover, may otherwise not be noticed until it is too late to put them right at moderate cost. Your authorised BMW Motorrad dealer's mechanics know every detail of your motorcycle and can take remedial action if necessary before minor faults develop into serious problems. By having the necessary repairs done properly and in good time, you save time and money in the long run.

BMW Motorrad mobility services - roadside assistance

In the event of a breakdown, the BMW Motorrad mobility services available for each new BMW motorcycle enable you to access an extensive range of services such as breakdown assistance, motorcycle transportation etc. (details can differ from country to country). In the event of a breakdown,

contact the Mobile Service organisation of BMW Motorrad. The specialists will provide the necessary advice and assistance. You will find important country-specific contact addresses and the after-sales service organisation phone numbers in the "Service Kontakt / Service Contact" brochures, along with information on Mobile Service and the dealership network.

BMW Motorrad service network

BMW Motorrad has an extensive after-sales service network in place to look after you and your motorcycle in more than 100 countries. In Germany alone, you have the best possible access to approximately 200 authorised BMW Motorrad dealers.

All information concerning the international dealership network can be found in the brochure

"Service Contact Europe" or "Service Contact Africa, America, Asia, Australia, Oceania".

Maintenance work

BMW Pre-delivery Check

Your authorised BMW Motorrad dealer conducts the BMW pre-delivery check before handing over the motorcycle to you.

BMW Running-in Check

The BMW running-in check has to be performed when the motorcycle has covered between 500 km and 1200 km

BMW Service

The BMW Service is carried out once a year; the extent of servicing can vary, depending on the age of the motorcycle and the distance it has covered. Your authorised BMW Motorrad dealer confirms that the service work has been carried out and enters

the date when the next service will be due.

Riders who cover long distances in a year might have to bring in their motorcycles for service before the next scheduled date. It is to allow for these cases that a maximum odometer reading is entered as well in the confirmation of service. Servicing has to be brought forward if this odometer reading is reached before the next scheduled date for the service.

Confirmation of maintenance work

BMW Pre-delivery Check

Completed

on _____

Stamp, signature

BMW Running-in Check

Completed

on _____

Odometer reading _____

Next service
at the latest

on _____

or, if logged beforehand,

Odometer reading _____

Stamp, signature

BMW Service

Completed

on _____

Odometer reading _____

Next service
at the latest

on _____

or, if logged beforehand,

Odometer reading _____

Stamp, signature**BMW Service**

Completed

on _____

Odometer reading _____

Next service
at the latest

on _____

or, if logged beforehand,

Odometer reading _____

Stamp, signature**BMW Service**

Completed

on _____

Odometer reading _____

Next service
at the latest

on _____

or, if logged beforehand,

Odometer reading _____

Stamp, signature

BMW Service

Completed

on _____

Odometer reading _____

Next service
at the latest

on _____

or, if logged beforehand,

Odometer reading _____

Stamp, signature**BMW Service**

Completed

on _____

Odometer reading _____

Next service
at the latest

on _____

or, if logged beforehand,

Odometer reading _____

Stamp, signature**BMW Service**

Completed

on _____

Odometer reading _____

Next service
at the latest

on _____

or, if logged beforehand,

Odometer reading _____

Stamp, signature

BMW Service

Completed

on _____

Odometer reading _____

Next service
at the latest

on _____

or, if logged beforehand,

Odometer reading _____

Stamp, signature**BMW Service**

Completed

on _____

Odometer reading _____

Next service
at the latest

on _____

or, if logged beforehand,

Odometer reading _____

Stamp, signature**BMW Service**

Completed

on _____

Odometer reading _____

Next service
at the latest

on _____

or, if logged beforehand,

Odometer reading _____

Stamp, signature

BMW Service

Completed

on _____

Odometer reading _____

Next service
at the latest

on _____

or, if logged beforehand,

Odometer reading _____

Stamp, signature**BMW Service**

Completed

on _____

Odometer reading _____

Next service
at the latest

on _____

or, if logged beforehand,

Odometer reading _____

Stamp, signature**BMW Service**

Completed

on _____

Odometer reading _____

Next service
at the latest

on _____

or, if logged beforehand,

Odometer reading _____

Stamp, signature

Confirmation of service

The table is intended as a record of maintenance and repair work, the installation of optional accessories and, if appropriate, special campaign (recall) work.

Item	Odometer reading	Date

A

Abbreviations and symbols, 6

ABS

Control, 16, 18

Engineering details, 56

Self-diagnosis, 46

Switching off and on, 33

Accessories

Notes, 60

Air filter

Position on the motorcycle, 13

Replacing, 92

B

Battery

Charging battery when connected, 95

Charging battery when disconnected, 96

Installation, 97

Maintenance instructions, 95

Position on the motorcycle, 11

Removal, 96

BMW Motorrad service, 120

Brake fluid

Checking fluid level, front, 72

Checking fluid level, rear, 73

Reservoir, front, 13

Reservoir, rear, 13

Brake pads

Checking front, 70

Checking rear, 71

Running in, 47

Brakes

Checking operation, 70

Safety instructions, 49

Technical data, 113

Bulbs

Notes on replacement, 86

Replacing brake-light bulb, 91

Replacing high-beam headlight bulb, 87

Replacing low-beam headlight bulb, 87

Replacing rear light bulb, 91

Replacing side-light bulb, 89

Replacing turn indicator bulb, 90

Technical data, 114

C

Care, 101

Case

Operation, 61

Chain

Adjusting sag, 77

Checking sag, 77

Checking wear, 78

Label, chain tension, 13

Lubricating, 76

Checklist, 44

Clock

Adjusting, 29

Control, 15

Clutch

Adjusting handlebar lever, 34

Checking play, 75

handlebar-lever play, adjusting, 75

Technical data, 111

Confirmation of maintenance

work, 122

Coolant

Checking fill level, 74

Fill-level indicator, 11

Topping up, 74

Coolant temperature
Warning, 24

D

Damping
Adjuster, 13
Adjusting, 36
Dimensions, 116

E

Electrics
Technical data, 114
Emergency off switch (kill
switch), 17, 32
Engine
Starting, 44
Technical data, 109
Engine oil
Checking fill level, 68
Filler neck, 11
Oil dipstick, 11
Technical data, 110
Topping up, 70
Equipment, 6

F

Frame
Technical data, 116
Front-wheel stand
Installing, 84
Fuel
Filler neck, 13
Refuelling, 50
Technical data, 110
Warning, 24
Fuses
Position on the motorcycle, 14
Replacing, 86

G

General views
Extra switch, 18
Instrument panel, 15
Left handlebar fitting, 16
Left side of motorcycle, 11
Multifunction display, 20
Right handlebar fitting, 17
Right side of motorcycle, 13
Underneath the seat, 14
Warning and telltale lights, 21

Grip heating
Operation, 32

H

Handlebar fitting, left
Overview, 16
Handlebar fitting, right
Overview, 17
Hazard warning flashers
Control, 18
Operation, 31
Headlight
Adjusting headlight beam
throw, 38
Beam throw, 38
Driving on right/driving on
left, 38
Headlight flasher, 31
Control, 16
High-beam headlight
Control, 16
Horn, 16

- I**
Ignition
 Switching off, 28
 Switching on, 28
Instrument panel
 Overview, 15
- J**
Jump starting, 94
- K**
Keys, 28
- L**
Laying up, 104
Lights
 High-beam headlight, 31
 Switch on the parking lights, 28
 Switching on low-beam headlight, 31
 Switching on the parking lights, 30
Lowered suspension
 Restrictions, 42
- Luggage
 Instructions for loading and securing objects, 42
- M**
Maintenance
 Notes, 68
Maintenance intervals, 121
Mirrors
 Adjusting, 35
Mobility services, 120
Motorcycle
 Care, 101
 Laying up, 104
 Parking, 50
 Restoring to use, 104
Multifunction display, 15
 Overview, 20
 Select the readings, 30
- O**
Odometer and tripmeters
 Control, 15
Off-roading, 48

- P**
Parking, 50
Power socket
 Notes on use, 60
 Position on the motorcycle, 11
Pre-ride check, 46
- R**
Rear-wheel drive
 Technical data, 112
Redline warning, 48
 Indicator, 15
Refuelling, 50
Rider's Manual
 Position on the motorcycle, 14
Running gear
 Technical data, 112
Running in, 47
- S**
Safety instructions, 42
 for brake, 49
Seat
 Installation, 38
 Lock, 11
 Removal, 38

Service, 120
Side light
 Switching on, 30
Spark plugs
 Technical data, 114
Speedometer, 15
Spring preload
 Adjuster, 13
 Adjusting, 35
Standards, 7
Starting, 44
 Control, 17
Steering lock, 29

T

Technical data
 Brakes, 113
 Bulbs, 114
 Clutch, 111
 Dimensions, 116
 Electrics, 114
 Engine, 109
 Engine oil, 110
 Frame, 116
 Fuel, 110

Rear-wheel drive, 112
Running gear, 112
Spark plugs, 114
Standards, 7
Transmission, 111
Tyres, 113
Weights, 117
Wheels, 113
Telltale lights, 15
 Overview, 21
Toolkit
 Contents, 68
 Position on the motorcycle, 14
topcase
 Operation, 63
Torques, 107
Transmission
 Technical data, 111
Transportation
 Lashing, 52
troubleshooting chart, 106
Turn indicators
 Control, 16
Type plate
 Position on the motorcycle, 13

Tyres

 BMW recommendations, 113
 Checking inflation pressure, 37
 Pressures, 114
 Recommendations, 78
 Running in, 47
 Table of tyre pressures, 11, 14
 Technical data, 113

V

Vehicle identification number
 Position on the motorcycle, 13

W

Warning lights, 15
 Overview, 21
Warnings, overview, 23
Weights, 117
 Payload table, 14
Wheels
 Change of size, 78
 Install the rear wheel, 83
 Installing front wheel, 80
 Removing rear wheel, 81
 Technical data, 113

Motorcycle data/dealership details

Motorcycle data

Model

Vehicle identification number

Colour code

Date of first registration

Registration number

Dealership details

Person to contact in Service department

Ms/Mr

Phone number

Dealership address/phone number (company stamp)

Details described or illustrated in this booklet may differ from the motorcycle's actual specification as purchased, the accessories fitted or the national-market specification. No claims will be entertained as a result of such discrepancies.

Dimensions, weights, fuel consumption and performance data are quoted to the customary tolerances.

The right to modify designs, equipment and accessories is reserved.

Errors and omissions excepted.

© 2010 BMW Motorrad

Not to be reproduced either wholly or in part without written permission from BMW Motorrad, After Sales.

Printed in Germany.

Important data for refuelling

Fuel

Recommended fuel grade	Regular, unleaded 91 ROZ/RON 87 AKI
------------------------	---

Usable fuel capacity	approx. 14 l
----------------------	--------------

Reserve fuel	approx. 4 l
--------------	-------------

Tyre pressure

Tyre pressure, front	2.2 bar, Tyre cold
----------------------	--------------------

Tyre pressure, rear	2.5 bar, one-up, tyre cold 2.9 bar, two-up and with luggage, tyre cold
---------------------	---

BMW recommends 

Order No.: 01 41 8 522 231
11.2010, 1st edition

