



# FirePoint

## 5000



# ENGINEERS OPERATING GUIDE



## Table of Contents

<b>Section</b>	<b>Page No</b>
1. HOW TO RESET FIRE & FAULT EVENTS.....	6
2. HOW TO ENTER THE SYSTEM EVENT LOG.....	7
3. HOW TO ENTER THE SYSTEM EVENT LOG WITH FAULTS DISPLAYED.....	8
4. HOW TO DISABLE DEVICES.....	9
5. HOW TO RE-INSTATE DEVICES FROM DISABLEMENT.....	11
6. HOW TO DISABLE A DEVICE ACROSS A NETWORK SYSTEM.....	12
7. HOW TO RE-INSTATE A DISABLED DEVICE ACROSS A NETWORK.....	14
8. HOW TO LOG ON A DEVICE.....	16
9. HOW TO REMOVE A DEVICE.....	18
10. HOW TO REPLACE DEVICES.....	20
11. HOW TO PUT DETECTOR ZONES INTO TEST (TESTING DEVICES).....	23
12. HOW TO TAKE DETECTOR ZONES OUT OF TEST.....	25
13. HOW TO PUT ALL THE ZONES INTO TEST ACROSS A NETWORK.....	26
14. HOW TO TAKE ALL THE ZONES OUT OF TEST ACROSS A NETWORK.....	28
15. HOW TO TEST INDIVIDUAL SOUNDERS.....	30
16. HOW TO CHANGE THE DEVICE ADDRESS TEXT DESCRIPTION.....	32
17. RECOMMENDED ADDITIONAL SOUNDER MONITORING.....	34
18. FAULT LIST.....	35
19. DO'S AND DON'TS.....	36

**SYSTEM 5000**

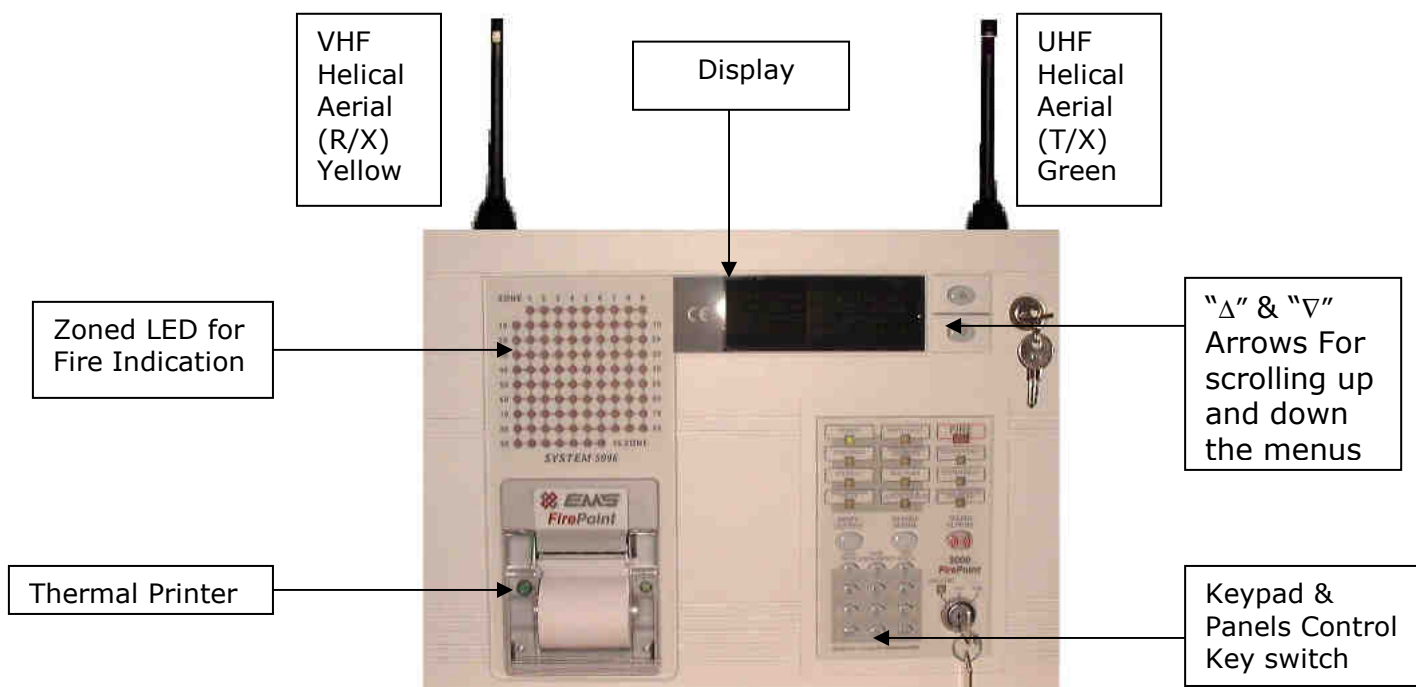

**CONTROL PANELS ARE SUPPLIED WITH ALL DETECTOR ZONES IN TEST. PLEASE REFER TO SECTIONS 12 OR 14 IN THIS MANUAL TO MAKE ACTIVE.**

**Options Menu Structure**

**Key in "OFF" position  
with Password Entered:**

**Options**  
Passwords  
Time and Date  
Logging  
Fire System Opts  
Checksum Info  
Radio Lan Opts  
Lan Control

**Pins & Access**  
User Log On  
View Users  
Change PIN  
Add 6 Digit User  
Add 4 Digit User  
Edit User  
Delete User  
Access And Buzzer  
User Options Order  
Front Screen Text  
Site Address Text  
Delete All Users!

**Time/Date**  
Set the Time  
View the Date  
Set the Date  
View BST/GMT  
Set BST/GMT  
Day-Night Ctrl

**Event Logging**  
View Log At Date  
View Entire Log  
View Log Group  
Print Log By Date  
Print Entire Log  
Processor Resets

**Fire System**  
Dev. Disable/Test  
Net. Disable/Test  
Det Zone  
Disable/Test  
Alarm Zone Disable  
ARE Disable  
System Mode  
Engineers Config

**Checksum Ctrl**  
View Checksums  
Monitor Checksums

**Radio LAN**  
Node Table  
Re-Start Lan  
Re-Online Node  
Node Setup  
View/Delete Node  
Advanced

**LAN Fire DB**  
H/W Local Panels  
Mimic  
Advanced

**1. How To Reset Fire & Fault Events.**

To reset fires/faults on the 5000 FirePoint, insert the Key into the Panel’s Control Key switch, located at the right of the Panel. Turn the Key to the “ON” Position.

Step No	Action	Screen Display
1	This a normal Fire Event	<div style="border: 1px solid black; padding: 5px;"> <p>01 FIRE ALARM TOT 01 RADIO CALLPOINT</p> <p>ZONE 01    DEVICE 005</p> </div>
2	Press the “SILENCE ALARMS” button and the screen will now briefly display: (Press Any Key). Having silenced the System’s Sounders and Internal Buzzers, an intermittent beep every 10 – 15 seconds will occur until reset.	<div style="border: 1px solid black; padding: 5px;"> <p>Alarms Silenced</p> <p>Push Any Key</p> </div>
3	Press the “RESET/LED TEST” button and the screen will now briefly display: (Press Any Key)	<div style="border: 1px solid black; padding: 5px;"> <p>Device RESET:</p> <p>RADIO CALLPOINT</p> <p>Push Any Key</p> </div>
4	The Event is now clear, so the key switch can be returned to the “OFF” position. The screen will now display:	<div style="border: 1px solid black; padding: 5px;"> <p>Status Normal</p> <p>Date                      Time</p> </div>

## 2. How To Enter The System Event Log

To enter the Systems Event Log on the 5000 FirePoint, insert the key into the Panels Control Key switch, located at the right of the panel. Turn the key to the "ON" position.

Step No	Action	Screen Display
1	With the key in the "ON" position, the screen will display:	<pre> Panel in Access Date           Time                     </pre>
2	Press the "0" key and the screen will now display:	<pre>  **Options**  &gt;Passwords  &lt;  Time and Date  Yes =Select   Time                     </pre>
3	Press the "∇" key until the screen displays:	<pre>  Time and Date  &gt;Logging     &lt;  Fire System Opts  YES = Select   Time                     </pre>
4	Press the "YES" key and the screen will now display:	<pre>  **Event Logging*  &gt;View Log At Date&lt;  View Entire Log  Yes = Select   Time                     </pre>
5	Press the "YES" key and the screen will now display:	<pre> Enter the date to View:  /  / Yes = Finish   Time                     </pre>
6	Enter the required date to view in dd/mm/yy Format, (e.g.28/05/03) then press the "YES" key and the screen will now display:	<pre> ----- On 28/05/03 At 00:00 New Day of 28/05/03 Yes = Select   Time                     </pre>

The log for the date selected can be viewed by using the "Δ" & "∇" Arrows next to the display, all fire and fault events are listed in date and time order. Using number 5 on the keypad will take you to the oldest event, number 8 on the keypad will take you to the latest event. (Look at the fault list for examples of descriptions that are in the log)

### 3. How To Enter The System Event Log With Faults Displayed

To enter the system event log on the 5000 FirePoint with faults displayed there are two ways.

The first way is to disable the devices that are in fault then enter the logging in the first menu. The second way is to enter the engineer's menu main. To enter the engineer's main menu insert the key into the Panels Control Key switch, located at the right of the Panel and turn it to the "ON" position.

Step No	Action	Screen Display
1	With the key in the "ON" position, the screen will display:	01 FAULT TOT 03 Default Device 001  Zone 01 Device 001
2	Press the "0" key and the screen will now display:	** Fire system **   >Dev. Disable/Test <   Net. Disable/Test   Yes= Select Time
3	Press the "∇" key until the screen displays:	System Mode   > Engineers Config <   Printer Options   Yes= Select Time
4	Press the "YES" key and the screen will now display:	Enter Your PIN For Access> Then Press YES Time
5	Press 221100 then press the "YES" key and the screen will display:	** Eng. Config **   >Device Database <   Sounder Options   Yes= Select Time
6	Press Number 8 on the keypad and the screen will now display: (number is a quick move key that takes you to the bottom of the menu)	Reset System   >Lan Options <   ^^^^^^^^^^^^^^^^^   Yes= Select Time
7	Press the "Δ" key until the screen displays:	Reset Security   >Reset System <   Lan Options   Yes= Select Time
8	Press the "YES" key followed by the "0" key on the keypad the screen will now display:	** Main Menu **   >Pins & Access <   System Support   Yes= Select Time
9	Press the "∇" key until the screen displays:	Output Setup   >Logging <   Remote Rxers   Yes= Select Time
10	Press the "YES" key and the screen will now display:	**Event Logging *   >View Log At Date <   View Entire Log   Yes = Select Time



11	Press the "YES" key and the screen will now display:	Enter the date to View: / /  Yes = Finish
12	Enter the required date to view in dd/mm/yy format, (e.g.28/05/03) then press the "YES" key and the screen will now display:	----- On 28/05/03 At 00:00 New Day of 28/05/03 Yes = Select

The log for the date selected can be viewed by using the "▲" & "▼" Arrows next to the display, all fire and fault events are listed in date and time order. Using number 5 on the keypad will take you to the oldest event, number 8 on the keypad will take you to the latest event. (Look at the fault list for examples of descriptions that are in the log).

### 4. How To Disable Devices

To disable a device on the 5000 FirePoint, insert the key into the Panels Control Key switch, located at the right of the Panel. Turn the key to the "ON"

Step No	Action	Screen Display
1	With the key in the "ON" position, the screen will display:	Panel in Access  Date                      Time
2	"0" key and the screen will now display:	***Options ****   >Passwords <  Time and Date   Yes =Select              Time
3	Press the "▼" key until the screen displays:	Logging   >Fire System Opts<   Remote Access   Yes = select              Time
4	Press the "YES" key and the screen will now display:	** Fire system **   >Dev. Disable/Test<   Net. Disable/Test   Yes= Select              Time
5	Press the "YES" key and the screen will now display:	** Device Status *   >Number is: 001 <  Status is: ACTIVE  Yes= Select              Time
6	Press the "0" key and the screen will now display:	Enter Device (Number 1-256) Number > _ Yes = Finish              Time _
7	Enter the device number that you want to Disable (e.g. 125) then press the "YES" key and the Screen will now display:	** Device Status *   >Number is: 125 <  Status is: ACTIVE  Yes= Select              Time

EMS 5000 FIREPOINT

8 Press the "∇" key until the screen displays:

```
| Number is: 125 |  
> Status is: ACTIVE<  
| Zone is : 01 |  
Yes= Select Time
```

9 Press the "YES" key and the screen will now display:

```
| Number is: 125 |  
>Status is :DISABLE<  
| Zone is : 01 |  
Yes= Select Time
```

10 Press the "NO" key three times and the screen will now display:

```
Panel in Access  
Date Time
```

11 Turn the Control key to the "OFF" position and the screen will now display:

```
Status Normal  
Date Time
```

**Note: The "DETECTOR/ZONE DISABLED" LED on the 5000 FirePoint Panel will illuminate with an intermittent beep to show there's a Disabled device on the system.**

## **5. How To Re-instate Devices From Disablement**

To reactivate a device on the 5000 FirePoint, insert the key into the Panels Control Key switch, located at the right of the panel. Turn the key to the "ON" position.

Step No	Action	Screen Display
1	With the key in the "ON" position, the screen will display:	<pre> Panel in Access Date           Time                     </pre>
2	Press the "0" key and the screen will now display:	<pre>  ***Options***   &gt;Passwords     &lt;  Time and Date   Yes =Select    Time                     </pre>
3	Press the "∇" key until the Screen displays:	<pre>   Logging        &gt;Fire System Opts &lt;  Remote Access   Yes = select   Time                     </pre>
4	Press the "YES" key and the screen will now display:	<pre>  ** Fire system **   &gt;Dev. Disable/Test &lt;   Net. Disable/Test   Yes= Select       Time                     </pre>
5	Press the "YES" key and the screen will now display:	<pre>   ** Device Status *   &gt;Number is: 001 &lt;  Status is: ACTIVE   Yes= Select       Time                     </pre>
6	Press the "0" key and the screen will now display:	<pre> Enter Device (Number 1-256) Number &gt; _ Yes = Finish    Time                     </pre>
7	Enter the device number that you want to Re-enable (e.g. 125) then press the "YES" key and the Screen will now display:	<pre>   ** Device Status *   &gt;Number is: 125 &lt;  Status is: DISABLE   Yes= Select       Time                     </pre>
8	Press the "∇" key once and the screen will display:	<pre>  Number is: 125   &gt;Status is: DISABLE&lt;   Zone is : 01   Yes= Select    Time                     </pre>
9	Press the "YES" key twice and the screen will now display:	<pre>  Number is: 125   &gt;Status is: ACTIVE &lt;   Zone is : 01   Yes= Select    Time                     </pre>
10	Press the "NO" key three times and the screen will now display:	<pre> Panel in Access Date           Time                     </pre>
11	Return the Control key to the "OFF" position and the screen will now display:	<pre> Status Normal Date           Time                     </pre>

**Note: The "DETECTOR/ZONE DISABLED" LED on the 5000 FirePoint Panel will clear and the Disable beep will stop.**

## **6. How To Disable A Device Across A Network System**

To disable a device across the network on the 5000 FirePoint, insert the key into the Panels Control Key switch, located at the right of the panel.

Step No	Action	Screen Display
1	With the key in the "ON" position, the screen will display:	<pre> Panel in Access Date                Time                     </pre>
2	Press the "0" key and the screen will now display:	<pre>   ***Options ****     &gt;Passwords      &lt;     Time and Date       Yes =Select     Time</pre>
3	Press the "∇" key until the screen displays:	<pre>   Logging              &gt;Fire System Opts &lt;     Remote Access       Yes = select    Time</pre>
4	Press the "YES" key and the screen will now display:	<pre>   ** Fire system **     &gt; Dev. Disable /Test&lt;     Net. Disable /Test     Yes= Select       Time</pre>
5	Press the "∇" key once and the screen will display:	<pre>   Dev. Disable/Test     &gt;Net. Disable/Test &lt;     Det Zone Dis/Test     Yes= Select       Time</pre>
6	Press the "YES" key and the screen will now display: (move on to step 8 if H/W)	<pre>   * Network Status *     &gt; Panel Type : PAN &lt;     Panel      : 00        Yes= Select   Time</pre>
7	Press the "YES" key once the Screen will now display:	<pre>   * Network Status *     &gt; Panel Type : NET &lt;     Panel      : 00        Yes= Select   Time</pre>
<p><b>NOTE: PAN is for a Hardwired based System. NET is for a Radio LAN based system.</b></p>		
8	Press the "∇" key once and the screen will display:	<pre>   Panel Type : PAN     &gt; Panel      : 00 &lt;     Device      : 00     Yes= Select   Time</pre>
9	Press the "YES" key to change the panel number until the required panel number is shown: (e.g. 04)	<pre>   Panel Type : NET     &gt; Panel      : 04 &lt;     Device      : 00     Yes= Select   Time</pre>
10	Press the "∇" key once and the screen will display:	<pre>   Panel      : 04     &gt; Device    : 00 &lt;     Status     : Active     Yes= Select   Time</pre>

EMS 5000 FIREPOINT

11	Press the "0" key and the screen will now display:	<pre> Enter Device (Number 1-256) Number &gt;_ Yes = Finish    Time                     </pre>
12	Enter the device number that you want to Disable (e.g. 125) then press the "YES" key and screen will now display:	<pre>   Panel   : 04     &gt;Device  : 125 &lt;   Status  : Active   Yes= Select    Time                     </pre>
13	Press the "∇" key once and the screen will display:	<pre>   Device  : 125     &gt; Status  : Active &lt;   Transmit Event   Yes= Select    Time                     </pre>
14	Press the "YES" key once the screen will now display:	<pre>   Device  : 125     &gt;Status  : Disable&lt;   Transmit Event   Yes= Select    Time                     </pre>
15	Press the "∇" key once and the screen will display:	<pre>   Status  : Disable   &gt;Transmit Event &lt;   ^^^^^^^^^^^^^^^^^   Yes= Select    Time                     </pre>
16	Press the "YES" key once the Screen will now display:	<pre> Device 125 on NET 04 Set to DISABLED  Push Any Key    Time                     </pre>
17	Press the "NO" key three times and the screen will display:	<pre> Panel in Access  Date            Time                     </pre>
18	Turn the Control key to the "OFF" Position. The screen will now display:	<pre> Status Normal  Date            Time                     </pre>

**Note: The "DETECTOR/ZONE DISABLED" LED on the 5000 FirePoint Master Panel and the 5000 FirePoint Slave Panel 04 will illuminate with intermittent beep to show there's a disablement on the system.**

## 7. How To Re-instate a Disabled Device Across a Network

To re-instate a Disabled a device across the network on the 5000 FirePoint, insert the key into the Panels Control Key switch, located at the right of the panel.

Step No	Action	Screen Display
1	With the key in the "ON" position, the screen will display:	<pre> Panel in Access Date           Time                     </pre>
2	Press the "0" key and the screen will now display:	<pre>  ***Options ****   &gt;Passwords      &lt;   Time and Date    Yes =Select     Time                     </pre>
3	Press the "∇" key until the screen displays:	<pre>   Logging          &gt;Fire System Opts &lt;   Remote Access    Yes = select    Time                     </pre>
4	Press the "YES" key and the screen will now display:	<pre>  ** Fire system **   &gt;Dev. Disable/Test &lt;   Net. Disable/Test   Yes= Select       Time                     </pre>
5	Press the "∇" key until the screen displays:	<pre>   Dev. Disable/Test   &gt;Net. Disable/Test &lt;   Det Zone Dis/Test   Yes= Select        Time                     </pre>
6	Press the "YES" key and the screen will now display:	<pre>  * Network Status *   &gt;Panel Type : PAN &lt;   Panel       : 00    Yes= Select       Time                     </pre>
<p><b>NOTE: PAN is for a Hardwired based System. (Go to step 7). NET is for a Radio LAN based system. (Go to step 8).</b></p>		
7	Press the "YES" key to select the required panel type and the Screen will now display:	<pre>  * Network Status *   &gt; Panel Type: NET&lt;   Panel       : 00    Yes= Select       Time                     </pre>
8	Press the "∇" key until the screen will display: (Where Panel type = NET/PAN)	<pre>   Panel Type : NET   &gt;Panel       : 00  &lt;   Device     : 00    Yes= Select       Time                     </pre>
9	Press the "YES" key to change the panel number until the required panel number is shown: (e.g. 04)	<pre>   Panel Type : NET   &gt;Panel       : 04  &lt;   Device     : 00    Yes= Select       Time                     </pre>
10	Press the "∇" key until the screen displays:	<pre>  Panel       : 04    &gt;Device     : 00  &lt;  Status     :Disable   Yes= Select       Time                     </pre>

EMS 5000 FIREPOINT

11 Press the "0" key and the screen will now display:

```

Enter Device
(Number 1-256)
Number > _
Yes = Finish   Time
    
```

12 Enter the device number that you want to re-instate (e.g. 125) then press the "YES" key and screen will now display:

```

| Panel   : 04 |
> Device  : 125 <
| Status  :Disable|
Yes= Select   Time
    
```

13 Press the "∇" key until the screen displays:

```

| Device   : 125 |
> Status   :Disable <
| Transmit Event |
Yes= Select   Time
    
```

14 Press the "YES" key once the Screen will now display:

```

| Device   : 125 |
> Status   : Active <
| Transmit Event |
Yes= Select   Time
    
```

15 Press the "∇" key until the screen displays:

```

| Status   : Active |
> Transmit Event <
| ^^^^^^^^^^^^^^^^^ |
Yes= Select   Time
    
```

16 Press the "YES" key once the Screen will now display:

```

Device 125 on NET 04
Set to ACTIVE
Push Any Key   Time
    
```

17 Press the "NO" key until the screen displays:

```

Panel in Access
Date           Time
    
```

18 Turn the Control key to the "OFF" Position. The screen will now display:

```

Status Normal
Date           Time
    
```

**Note: The "DETECTOR/ZONE DISABLED" LED on the 5000 FirePoint Master Panel and System 5000 Slave Panel will clear and the Disable beep will stop.**

## **8. How To Log On A Device**

To log on a device onto the 5000 FirePoint, take the device in front of the panel. Insert the key into the Panels Control Key switch, located at the right of the Panel.

Step No	Action	Screen Display
1	With the key in the "ON" position, the screen will display:	<pre> Panel in Access Date           Time                     </pre>
2	Press the "0" key and the screen will now display:	<pre>  **Options** *   &gt; Passwords &lt;   Time and Date   Yes =Select     Time                     </pre>
3	Press the "∇" key until the screen displays:	<pre>   Logging   &gt; Fire System Opts &lt;   Remote Access   Yes = select     Time                     </pre>
4	Press the "YES" key and the screen will now display:	<pre>  ** Fire system **   &gt; Dev. Disable/Test&lt;   Net. Disable/Test   Yes= Select     Time                     </pre>
5	Press the "∇" key until the screen displays:	<pre>   System Mode   &gt;Engineers Config &lt;   Printer Options   Yes= Select     Time                     </pre>
6	Press the "YES" key and the screen will now display:	<pre> Enter Your PIN For Access&gt; Then Press YES Time                     </pre>
7	Press 221100 then press the "YES" key and the screen will display:	<pre>  ** Eng.; Config **   &gt; Device Database &lt;   Sounder Options   Yes= Select     Time                     </pre>
8	Press the "∇" key until the screen displays:	<pre>   Sounder Options   &gt; Log On Devices &lt;   Site Survey   Yes= Select     Time                     </pre>
9	Press the "YES" key and the screen will now display:	<pre> Logon DISABLED(000) Push YES to change Push NO to escape Push YES/NO     Time                     </pre>
10	Press the "YES" key to change and the screen will now display:	<pre>  **Logon Options**   &gt; Logon Slot :AUTO&lt;   Slot is :FREE   Yes= Select     Time                     </pre>
11	Press the "0" key and the screen will now display:	<pre> Enter Device (Numbers 1-256) Number&gt; Yes= Finish     Time                     </pre>



12 Enter the slot number that you want to add a device to (e.g. 125) then press the "YES" key and the Screen will now display:

```
| **Logon Options** |
> Logon Slot :125 <
| Slot is :FREE |
Yes= Select Time
```

13 Press the "▽" key until the screen displays:

```
| Slot is :IN USE |
>Logon is DISABLED<
| /VVVVVVVVVV \ |
```

14 Press the "YES" key and the screen will now display:

```
| Slot is :IN USE |
>Logon is ENABLED <
| /VVVVVVVVVV \ |
```

15 Take the device you want to log on. Press and hold the logon button for 2-3 seconds (e.g. Figure 1) and the screen will now display:

```
Logon Default Device
125
Yes= Select Time
```

```
Added Default Device
125
Yes= Select Time
```

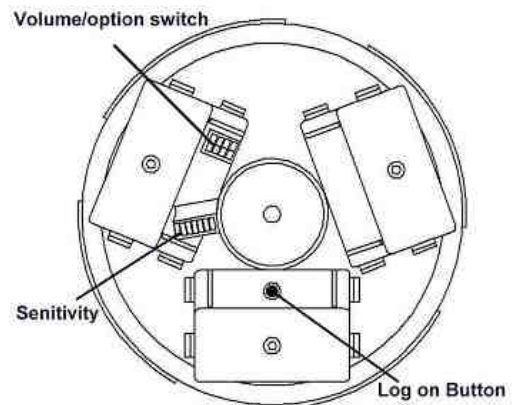
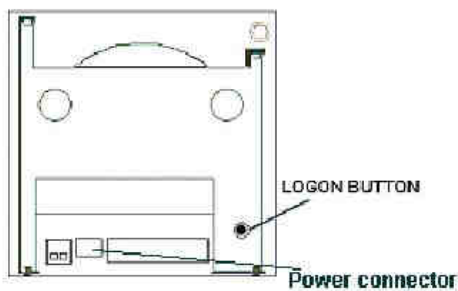
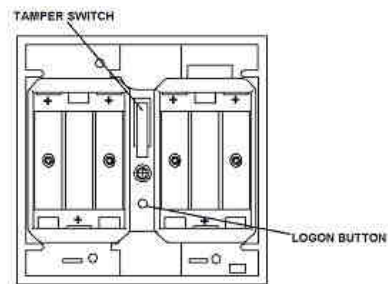
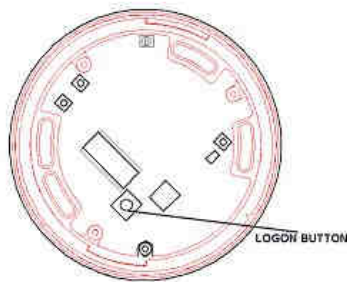

**Figure 1**

16 Press the "YES" key twice and the screen will now display:

```
| Slot is      :IN USE |
>Logon is DISABLED<
| /VVVVVVVVVV \ |
```

17 Press the "NO" key three times and the screen will now display:

```
01 FAULT   TOT 02
Default Device 125

ZONE 01 DEVICE 125
```

**Note: After logging the device on to the system there will be two faults:-**  
**1<sup>st</sup> fault is processor reset. (Silence and reset E.G. Page 5)**  
**2<sup>nd</sup> fault is the Tamper. (Make sure the device tamper is clear then silence and reset E.G. page 5)**

18 After the faults have been cleared, turn the control key to the "OFF" position and the screen will display:

```
Status Normal

Date           Time
```

**9. How To Remove A Device**

To remove a device from the 5000 FirePoint, insert the key into the Panels Control Key switch, located at the right of the panel.

Step No	Action	Screen Display
1	With the key in the "ON" position, the screen will display:	<pre>Panel in Access  Date           Time</pre>
2	Press the "0" key and the screen will now display:	<pre>  ***Options ***   &gt;Passwords      &lt;   Time and Date    Yes =Select     Time</pre>
3	Press the "∇" key until the screen displays:	<pre>  Logging          &gt; Fire System Opts &lt;   Remote Access    Yes = select    Time</pre>
4	Press the "YES" key and the screen will now display:	<pre>  ** Fire system **   &gt; Dev. Disable/Test &lt;   Net. Disable/Test   Yes= Select      Time</pre>
5	Press the "∇" key until the screen displays:	<pre>  System Mode      &gt; Engineers Config &lt;   Printer Options   Yes= Select     Time</pre>
6	Press the "YES" key and the screen will now display:	<pre>Enter Your PIN For Access&gt; Then Press YES Time</pre>

7	Press 221100 then press the "YES" key and the screen will display:	<pre>  ** Eng.; Config **   &gt;Device Database &lt;   Sounder Options   Yes= Select      Time                     </pre>
8	Press the "▽" key until the screen displays:	<pre>   Site Survey        &gt;Remove Devices &lt;   Panel Hardware    Yes= Select      Time                     </pre>
9	Press the "YES" key and the screen will now display:	<pre> Enter Device (Numbers 1-256) Number &gt; _ YES = Finish      Time                     </pre>
10	Enter the device number you want to delete (e.g. 005) and press the "YES" the screen will now display:	<pre> Device 5 Deleted Press Any Key      Time                     </pre>
11	Press ANY key and the screen will display:	<pre>   Site Survey        &gt;Remove Devices &lt;   Panel Hardware    Yes= Select      Time                     </pre>
12	Press the "NO" key three times and the screen will now display:	<pre> Panel in Access Date      Time                     </pre>
13	Turn the control key to the "OFF" Position. The screen will now display:	<pre> Status Normal Date      Time                     </pre>

**10. How To Replace Devices**

To replace a device onto the 5000 FirePoint, take the new device in front of the panel. Insert the key into the Panels Control Key switch, located at the right of the panel.

Step No	Action	Screen Display
1	With the key in the "ON" position, the screen will display:	<pre> Panel in Access Date                Time                     </pre>
2	Press the "0" key and the screen will now display:	<pre>  ***Options****   &gt; Passwords   &lt;    Time and Date  Yes =Select      Time                     </pre>
3	Press the "∇" key until the screen displays:	<pre>   Logging         &gt; Fire System Opts &lt;    Remote Access  Yes = select   Time                     </pre>
4	Press the "YES" key and the screen will now display:	<pre>  ** Fire system * *   &gt; Dev. Disable/Test &lt;    Net. Disable/Test   Yes= Select      Time                     </pre>
5	Press the "∇" key until the screen displays:	<pre>   System Mode     &gt; Engineers Config &lt;    Printer Options  Yes= Select    Time                     </pre>
6	Press the "YES" key and the screen will now display:	<pre> Enter Your PIN For Access&gt; Then Press YES Time                     </pre>
7	Press 221100 then press the "YES" key and the screen will display:	<pre>   ** Eng.; Config **    &gt; Device Database &lt;    Sounder Options   Yes= Select      Time                     </pre>
8	Press the "∇" key until the screen displays:	<pre>   Sounder Options    &gt; Log On Devices &lt;    Site Survey      Yes= Select      Time                     </pre>
9	Press the "YES" key and the screen will now display:	<pre> Logon DISABLED(000) Push YES to change Push NO to escape Push YES/NO      Time                     </pre>
10	Press the "YES" key to change and the screen will now display:	<pre>  **Logon Options**   &gt; Logon Slot :AUTO&lt;    Slot is      :FREE   Yes= Select      Time                     </pre>

11 Press the "0" key and the screen will now display:

```
Enter Device
(Numbers 1-256)
Number>
Yes= Finish      Time
```

12 Enter the slot number that you want to add a device to (e.g. 125) then press "YES" key and the Screen will now display:

```
**|Logon Options** |
>Logon Slot :125 <
| Slot is :FREE |
Yes= Select      Time
```

13 Press the "∇" key until the screen displays:

```
| Slot is :IN USE |
>Logon is DISABLED<
| /\/\/\/\/\/\/\ |
```

14 Press the "YES" key twice and the screen will now display:

```
| Slot is :IN USE |
>Logon is REPLACE <
| /\/\/\/\/\/\/\ |
```

15 Take the device you want to log on. Press and hold the logon button for 2-3 seconds (e.g. Figure 2) and the screen will now display:

```
Logon Default Device
125
Yes= Select      Time
```

```
Added Default Device
125
Yes= Select      Time
```

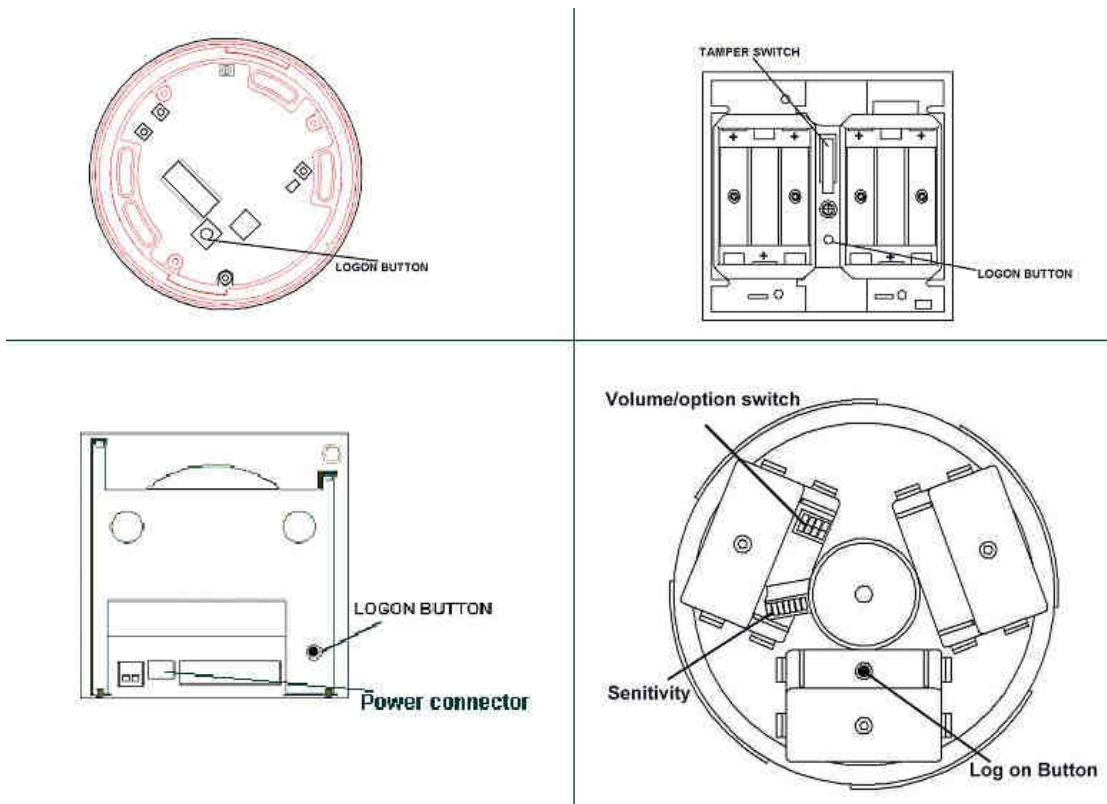

**Figure 2**

16 Press the "YES" key once and the screen will now display:

```
| Slot is      :IN USE |
>Logon is DISABLED<
| ^^^^^^^^^^^ |
```

17 Press the "NO" key three times and the screen will now display:

```
01 FAULT  TOT 02
Default Device 125

ZONE 01 DEVICE 125
```

**Note: After logging the device on to the system there will be two faults: -  
1<sup>st</sup> fault is processor reset. (Silence and reset E.G. Page 3)  
2<sup>nd</sup> fault is the Tamper. (Make sure the device tamper is clear then silence and reset E.G. page 3)**

18 After the faults have been cleared turn the control key to the "OFF" position. The screen will display:

```
Status Normal

Date           Time
```

## **11. How To Put Detector Zones Into Test (Testing Devices)**

To put zones into test for the 5000 FirePoint, insert the key into the Panels Control Key switch, located at the right of the panel. Turn the key to the "ON" position.

Step No	Action	Screen Display
1	With the key in the "ON" position, the screen will display:	<pre> Panel in Access Date                Time                     </pre>
2	Press the "0" key and the screen will now display:	<pre>  ***Options ****   &gt; Passwords      &lt;   Time and Date    Yes =Select      Time                     </pre>
3	Press the "YES" key and the screen will now display:	<pre>   *PIN's and ACCESS*   &gt;User Log ON      &lt;   View Users        Yes =Select      Time                     </pre>
4	Press the "YES" key and the screen will now display:	<pre> Enter Your PIN To Log On &gt; _ Then Press YES                     Time                     </pre>
5	Enter 221100 and press the "YES" key and the screen will now display:	<pre> ***** Welcome Engineer * ***** Push Any Key      Time                     </pre>
6	Press Any key and the screen will now display:	<pre>   Logging          &gt; Fire System Opts &lt;   Remote Access    Yes= Select      Time                     </pre>
7	Press the "∇" key until the screen displays:	<pre>  ***Options ****   &gt; Passwords      &lt;   Time and Date    Yes =Select      Time                     </pre>
8	Press the "YES" key and the screen will now display:	<pre>   ** Fire system **   &gt; Dev. Disable/Test&lt;   Net. Disable/Test   Yes= Select      Time                     </pre>
9	Press the "∇" key until the screen displays:	<pre>   Net. Disable/Test   &gt; Det Zone. Dis/Test &lt;   Alarm Zone Disable   Yes= Select      Time                     </pre>
10	Press the "YES" key and the screen will now display:	<pre>   ** Zone Status **   &gt; Zone is: 01      &lt;   Status : ACTIVE    Yes= Select      Time                     </pre>

11 Press the "∇" key and the screen will now display: (Make note of the status the zones is in e.g. ACTIVE, the status will need to be changed back Later)

```
| Zone is : 01 |
> Status : ACTIVE <
| ^^^^^^^^^^^^^^^^^ |
Yes= Select Time
```

12 Press the "YES" key twice and the screen will now display: (notice as the "YES" key is pressed the status changes)

```
| Zone is : 01 |
> Status : Test <
| ^^^^^^^^^^^^^^^^^ |
Yes= Select Time
```

13 Press the "Δ" key until the screen displays:

```
| ** Zone Status ** |
> Zone is: 01 <
| Status : Test |
Yes= Select Time
```

14 Press the "YES" key and the screen will now display:

```
| ** Zone Status ** |
> Zone is: 02 <
| Status : ACTIVE |
Yes= Select Time
```

15 Press the "∇" key until the screen displays:

```
| Zone is : 02 |
> Status : ACTIVE <
| ^^^^^^^^^^^^^^^^^ |
Yes= Select Time
```

16 Press the "YES" key and the screen will now display: (notice as the "YES" key is pressed the status changes)

```
| Zone is : 02 |
> Status : Test <
| ^^^^^^^^^^^^^^^^^ |
Yes= Select Time
```

**This needs to be repeated until all the Detector Zones are in test, then continue to step 18**

17 Press the "NO" key three times and the screen will now display:

```
Panel in Access
Date Time
```

18 Turn the control key to the "OFF" position. The screen will now display:

```
Status Normal
Date Time
```

**The devices are now ready to be activated, this includes smoking detectors and triggering call points. When a device is activated the 5000 FirePoint will go into fire, the display will show TEST ALARM and display the device number and text description. The Sounders/Relays will not activate.**

**NOTE: When smoking detectors their LEDs stay on for 20 minutes.**

**NOTE: For multi panel installations all zones on ALL panels must be put into test before testing is started.**



**12. How To Take Detector Zones Out Of Test**

To take zones out of test and back into original state i.e. all on the 5000 FirePoint, insert the key into the Panels Control Key switch, located at the right of the Panel. Turn the key to the "ON" Position.

Step No	Action	Screen Display
1	With the key in the "ON" position, the screen will display:	<pre> Panel in Access Date           Time                     </pre>
2	Press the "0" key and the screen will now display:	<pre>   ***Options ****     &gt; Passwords &lt;         Time and Date     Yes =Select     Time                     </pre>
3	Press the "∇" key until the screen displays:	<pre>     Logging          &gt;Fire System Opts &lt;     Remote Access     Yes= Select     Time                     </pre>
4	Press the "YES" key and the screen will now display:	<pre>   ** Fire system **     &gt; Dev. Disable/Test&lt;     Net. Disable/Test     Yes= Select     Time                     </pre>
5	Press the "∇" key until the screen displays:	<pre>     Net. Disable/Test     &gt;Det Zone. Dis/Test &lt;     Brigade Isolate     Yes= Select     Time                     </pre>
6	Press the "YES" key and the screen will now display:	<pre>     ** Zone Status **     &gt; Zone is: 01 &lt;     Status : Test     Yes= Select     Time                     </pre>
7	Press the "∇" key once and the screen will now display:	<pre>     Zone is : 01     &gt; Status : Test &lt;     ^^^^^^^^^^^^^^^^^^     Yes= Select     Time                     </pre>
8	Press the "YES" key twice and the screen will display: (This puts the status back to ACTIVE)	<pre>     Zone is : 01     &gt; Status : ACTIVE&lt;     ^^^^^^^^^^^^^^^^^^     Yes= Select     Time                     </pre>
9	Press the "Δ" key once and the screen will now display:	<pre>     ** Zone Status **     &gt; Zone is: 01 &lt;     Status : ACTIVE     Yes= Select     Time                     </pre>
10	Press the "YES" key and the screen will now display:	<pre>     ** Zone Status **     &gt; Zone is: 02 &lt;     Status : Test     Yes= Select     Time                     </pre>

EMS 5000 FIREPOINT

11 Press the "∇" key once and the screen will now display:

```
| Zone is : 02 |
> Status : Test <
| ^^^^^^^^^^^^^^^^^ |
Yes= Select Time
```

12 Press the "YES" key twice and the screen will now display: (notice as the "YES" key is pressed the status changes)

```
| Zone is : 02 |
> Status : ACTIVE<
| ^^^^^^^^^^^^^^^^^ |
Yes= Select Time
```

**This needs to be repeated until all the zones are set back to all, then continue to step 18.**

13 Press the "NO" key three times and the screen will now display:

```
Panel in Access
Date Time
```

14 Turn the control key to the "OFF" position and the screen will display:

```
Status Normal
Date Time
```

**13. How To Put All The Zones Into Test Across A Network**

How to put all the zones in to test across a Network (depending on which version of software) on the 5000 FirePoint, insert the key into the Panels Control Key switch, located at the right of the panel.

Step No	Action	Screen Display
1	With the key in the "ON" position, the screen will display:	<pre>Panel in Access Date Time</pre>
2	Press the "0" key and the screen will now display:	<pre>  ***Options ***   &gt; Passwords &lt;   Time and Date   Yes = Select</pre>
3	Press the "∇" key three times and press the "YES" key and the screen will now display:	<pre>  ** Fire system **   &gt; Dev. Disable/Test&lt;   Net. Disable/Test   Yes= Select Time</pre>
4	Press the "∇" key until the screen displays:	<pre>  System Mode   &gt; Engineers Config &lt;   Printer Options   Yes= Select Time</pre>
5	Press the "YES" key and the screen will now display:	<pre>Enter Your PIN For Access&gt; Then Press YES Time</pre>
6	Press 221100 then press the "YES" key and the screen will display:	<pre>  ** Eng. Config **   &gt; Device Database &lt;   Sounder Options   Yes= Select Time</pre>

7	Press Number 8 on the keypad and the screen will now display: (number is a quick move key that take you to the bottom of the menu)	<pre>  Reset System   &gt;Lan Options &lt;   ^^^^^^^^^^^^^   Yes= Select Time</pre>
8	Press the "Δ" key once and the screen will now display:	<pre>  Reset Security   &gt; Reset System &lt;   Lan Options   Yes= Select Time</pre>
9	Press the "YES" key followed "0" key on the Keypad the screen will now display:	<pre> ** Main Menu **  &gt; Pins &amp; Access &lt;   System Support   Yes= Select Time</pre>
10	Press Number 8 on the keypad and the screen will now display: (number is a quick move key that take you to the bottom of the menu)	<pre>  Radio Lan   &gt; Fire DB &lt;   ^^^^^^^^^^^^^   Yes= Select Time</pre>
11	Press the "YES" key and the screen will now display:	<pre> ** Lan Fire DB **  &gt; H/W Local Panels &lt;   Mimic   Yes= Select Time</pre>
12	Press the "∇" key until the screen displays:	<pre>  Mimic   &gt;Advanced &lt;   ^^^^^^^^^^^^^   Yes= Select Time</pre>
13	Press the "YES" key and the screen will now display:	<pre> *** Advanced ***  &gt;Get Slave Bus Lsts&lt;   ^^^^^^^^^^^^^   Yes= Select Time</pre>
14	Press the "∇" key until the screen displays:	<pre>  Local Mimic   &gt;Set Det.Zones &lt;   Announce All Clear  Yes= Select Time</pre>
15	Press the "YES" key and the screen will now display:	<pre> * Set All Zones *  &gt; ACTIVE &lt;   TEST   Yes= Select Time</pre>
16	Press the "∇" key and the screen will display:	<pre>  ACTIVE   &gt; TEST &lt;   DISABLED   Yes= Select Time</pre>
17	Press the "YES" key, the screen will stay the same but the test LED will start flashing to show that all the zones are in test.	<pre>  ACTIVE   &gt; TEST &lt;   DISABLED   Yes= Select Time</pre>

**NOTE: Check the other panels to make sure the "TEST MODE" LED is flashing to ensure no Sounders/Relays will activate.**

**14. How To Take All The Zones Out Of Test Across A Network**

How to take all the zones out of test across a network (depending on which version of software) on the 5000 FirePoint, insert the key into the Panels Control Key switch, located at the right of the panel.

Step No	Action	Screen Display
1	With the key in the "ON" position, the screen will display:	<pre> Panel in Access Date           Time                     </pre>
2	Press the "0" key and the screen will now display:	<pre>   ***Options ****     &gt;Passwords      &lt;     Time and Date       Yes =Select     Time                       </pre>
3	Press the "∇" key 3 times and press the "YES" key and the screen will now display:	<pre>   ** Fire system **     &gt;Dev. Disable/Test &lt;     Net. Disable/Test     Yes= Select       Time                       </pre>
4	Press the "∇" key until the screen displays:	<pre>   System Mode          &gt;Engineers Config &lt;     Printer Options      Yes= Select      Time                       </pre>
5	Press the "YES" key and the screen will now display:	<pre> Enter Your PIN For Access&gt; Then Press YES Time                     </pre>
6	Press 221100 then press the "YES" key and the screen will display:	<pre>   ** Eng.; Config **     &gt; Device Database &lt;     Sounder Options       Yes= Select       Time                       </pre>
7	Press Number 8 on the keypad and the screen will now display: (number is a quick move key that take you to the bottom of the menu)	<pre>   Reset System         &gt;Lan Options     &lt;     ^^^^^^^^^^^^^^^     Yes= Select      Time                       </pre>
8	Press the "Δ" key once and the screen will now display:	<pre>   Reset Security       &gt; Reset System   &lt;     Lan Options          Yes= Select      Time                       </pre>
9	Press the "YES" key followed "0" key on the keypad the screen will now display:	<pre>   ** Main Menu **     &gt; Pins &amp; Access  &lt;     System Support       Yes= Select      Time                       </pre>
10	Press Number 8 on the keypad and the screen will now display: (number is a quick move key that take you to the bottom of the menu)	<pre>   Radio Lan            &gt; Fire DB        &lt;     ^^^^^^^^^^^^^^^     Yes= Select      Time                       </pre>

EMS 5000 FIREPOINT

11	Press the "YES" key and the screen will now display:	<pre>  ** Lan Fire DB **   &gt;H/W Local Panels &lt;   Mimic             Yes= Select      Time                     </pre>
12	Press the "∇" key until the screen displays:	<pre>   Mimic             &gt;Advanced        &lt;   ^^^^^^^^^^^^^^^   Yes= Select      Time                     </pre>
13	Press the "YES" key and the screen will now display:	<pre>  *** Advanced ***   &gt; Get Slave Bus Lsts &lt;   ^^^^^^^^^^^^^^^   Yes= Select      Time                     </pre>
14	Press the "∇" key until the screen displays:	<pre>   Local Mimic       &gt; Set Det.Zones  &lt;   Announce All Clear   Yes= Select      Time                     </pre>
15	Press the "YES" key and the screen will now display:	<pre>  *Set All Zones *   &gt;ACTIVE           &lt;   TEST             Yes= Select      Time                     </pre>
16	Press the "YES" key, the screen will stay the same but the Test Mode LED extinguish to show that all the zones are now active.	<pre>  *Set All Zones *   &gt;ACTIVE           &lt;   TEST             Yes= Select      Time                     </pre>

**NOTE: Check the other panels to make sure the "TEST MODE" LED has stopped flashing to ensure Sounders/Relays are ready to activate.**

**15. How To Test Individual Sounders**

To test individual sounders on the 5000 FirePoint, Insert the key into the Panels Control Key switch, Located at the right of the panel.

Step No	Action	Screen Display
1	With the key in the "ON" position, the screen will display:	<pre> Panel in Access Date           Time                     </pre>
2	Press the "0" key and the screen will now display:	<pre>  **Options****  &gt;Passwords    &lt;   Time and Date  Yes =Select    Time                     </pre>
3	Press the "∇" key until the screen displays:	<pre>   Logging        &gt; Fire System Opts &lt;   Remote Access  Yes = select    Time                     </pre>
4	Press the "YES" key and the screen will now display:	<pre>  ** Fire system**  &gt; Dev. Disable/Test &lt;   Net. Disable/Test  Yes= Select     Time                     </pre>
5	Press the "∇" key until the screen displays:	<pre>   System Mode    &gt; Engineers Config &lt;   Printer Options  Yes= Select     Time                     </pre>
6	Press the "YES" key and the screen will now display:	<pre> Enter Your PIN For Access&gt; Then Press YES Time                     </pre>
7	Press 221100 then press the "YES" key and the screen will display:	<pre>  ** Eng.; Config**  &gt; Device Database &lt;   Sounder Options  Yes= Select     Time                     </pre>
8	Press the "∇" key once and the screen will display:	<pre>   Device Database  &gt;Sounder Options &lt;   Log On Devices  Yes= Select     Time                     </pre>
9	Press the "YES" key twice and the screen will now display: (the first press of Yes enters you into the sounder options menu the second press of Yes does a configure stop)	<pre>   Sounder Config  &gt; Configure STOP &lt;   Configure START  Yes= Select     Time                     </pre>
10	Press the "∇" key until the screen displays:	<pre>   Configure START  &gt;Configure ONE   &lt;   ^^^^^^^^^^^^^^^  Yes= Select     Time                     </pre>
11	Press the "YES" key and the screen will now display:	<pre>  ** Configure**  &gt;Sounder : ALLCFGD&lt;  Action :EVAC     Yes= Select     Time                     </pre>

12 Press the "YES" key to toggle though the device numbers until you get to the sounder that requires testing. (e.g. 025)

```
|** Configure ** |
>Sounder : 025 <
| Action : EVAC |
Yes= Select Time
```

13 Press the "▽" key once and the screen will display:

```
| Sounder : 025 |
>Action : EVAC <
| Do Action |
Yes= Select Time
```

14 Press the "YES" key to toggle though the different types of action commands. (E.g. press the "YES" key seven times takes you to test)

```
| Sounder : 025 |
>Action : TEST <
| Do Action |
Yes= Select Time
```

**There are 11 different types of actions: -**

- a EVAC:** The selected sounder will activate with the evac tone.
- b ALERT** The selected sounder will activate with the warning tone.
- C BOMB** The selected sounder will activate with the bomb tone.
- D LESS CHNG** The selected sounder will do a set of lesson change beeps.
- E AUX ON** Not Used.
- ALL OFF** The selected sounder will stop sounding. (I.e. Silence).
- G RX TEST** The receiver in the selected sounder will be sent a test message, the sounder will receive the message and send an acknowledgement message back to the 5000 panel.
- H TEST** The selected sounder will sound for four seconds and then turn off. The sounder will listen to it self and send an acknowledgement message back to the 5000 panel.
- I SET SYS** The 5000 panel will send a message to the selected sounder, which sets the system code in the selected sounder. The sounder then sends an acknowledgement message back to the 5000 panel.
- J JOIN GRP** The 5000 panel will send the zone information to the selected sounder, the selected sounder sends an acknowledgement back to the 5000 panel.
- K SET LS CH** The 5000 panel will send a message to the selected sounder which enables the lesson change, feature for the device.

15 Press the "▽" key once and the screen will display:

```
| Action : TEST |
>Do Action <
| ^^^^^^^^^^^^^^^ |
Yes= Select Time
```

16 Press the "YES" key and the screen will now display:

```
Device 025 Timer 9
Retry 07 REPLY NONE

Push Any Key Time
```

## EMS 5000 FIREPOINT

This timer will count down to 0, when the timer reaches 0 the retry should change to 6 and a message is sent to the sounder. If not, that means the panel is still busy and the timer will start again, when the retry number decreases listen for the selected sounder to activate. When the selected sounder has activated it sounds for four seconds and resets itself, watch the display for the acknowledgement message. (ACK)

```

Device 025 Timer 5
Retry 04 REPLY ACK

Push Any Key    Time
    
```

If the acknowledgement message has been received and a fault has not been reported the test is now complete.

17 Press Any key and the screen will now display:

```

| Action : TEST |
>Do Action      <
| ^^^^^^^^^^^^^ |
Yes= Select     Time
    
```

18 Press the "Δ" key until the screen displays:

```

|** Configure ** |
>Sounder : 025   <
| Action : FIRE  |
Yes= Select     Time
    
```

If you want to test another sounder repeat from step 13. If you have finished testing press the "NO" key until your back to the main screen (shown below). Then turn the key switch to the "OFF" position.

```

Status Normal

Date           Time
    
```

## **16. How To Change The Device Address Text Description**

To change the Text description on the 5000 FirePoint, Insert the key into the Panels Control Key switch, Located at the right of the panel.

Step No	Action	Screen Display
1	With the key in the "ON" position, the screen will display:	<pre> Panel in Access  Date           Time                 </pre>
2	Press the "0" key and the screen will now display:	<pre>  ***Options ****   &gt; Passwords      &lt;   Time and Date    Yes =Select     Time                 </pre>
3	Press the "∇" key until the screen displays:	<pre>   Logging          &gt;Fire System Opts &lt;   Remote Access    Yes = select     Time                 </pre>



4	Press the "YES" key and the screen will now display:	<pre>  ** Fire system **   &gt;Dev. Disable/Test &lt;   Net. Disable/Test   Yes= Select      Time                     </pre>
5	Press the "▽" key until the screen displays:	<pre>   System Mode        &gt;Engineers Config &lt;   Printer Options    Yes= Select      Time                     </pre>
6	Press the "YES" key and the screen will now display:	<pre> Enter Your PIN For Access&gt; Then Press YES                                 Time                     </pre>
7	Press 221100 then press the "YES" key and the screen will display:	<pre>  ** Eng. Config **   &gt;Device Database &lt;   Sounder Options    Yes= Select      Time                     </pre>
8	Press the "YES" key and the screen will now display:	<pre>   * FIRE DATABASE *   &gt;Device Number 001 &lt;  Default Device  001   Yes= Select      Time                     </pre>
9	Press the "0" key and the screen will now display:	<pre> Enter Device (Numbers 1-256) Number &gt; _ YES = Finish      Time                     </pre>
10	Enter the device number that you want to edit (e.g. 25) then press the "YES" key and the screen will now display:	<pre>   * FIRE DATABASE *   &gt;Device Number 025 &lt;  Default Device  025   Yes= Select      Time                     </pre>
11	Press the "▽" key once and the screen will display:	<pre>  Device Number 025   &gt;Default Device 025 &lt;  Device Zone    01   Yes= Select      Time                     </pre>
12	Press the "YES" key and the screen will now display: Enter your text description using the Function table. (the character selector is underneath M)	<pre>  Default Device 001                        4&lt;HIJKL M NOPQRS&gt;6                       </pre>

KEY	FUNCTION
0	Enters a blank space into the new device name being entered.
4	Moves the alphabet wheel of characters to the <b>Left</b> , by one character space at a time.
5	Enters the character in the <b>centre</b> directly above the character <b>selector  </b> .
6	Moves the alphabet wheel of characters to the <b>Right</b> , by one character space at a time.
7	Moves the flashing cursor to the <b>left</b> , through the new device name by one character space at a time.
8	Moves the alphabet wheel of characters to the <b>Right</b> , by 12 character Spaces at a time.
9	Moves the flashing cursor to the <b>Right</b> , through the new device name by one character space at a time.
↵	Backspace Key, <b>Deletes</b> by one character. (Deletes to the left only)
↵	Saves and completes the current activity and returns the program to the appropriate display.
NO	Allows the option of abandoning any changes and returning to the program.
YES	Saves and completes the current activity and returns the program to the appropriate display.

13 When completed and saved the text description use the "NO" key exit the menu's until the screen displays:

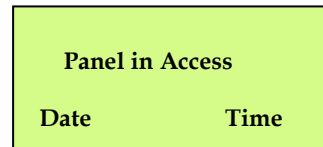

14 Turn the Key to the "OFF" position and the screen will display:

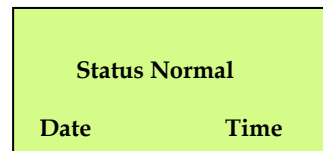

### **17. Recommended Additional Sounder Monitoring**

The 5000 FirePoint control panels have the ability to carry out additional checks on the UHF transmission path, which operates sounder type devices. This procedure is automatically implemented if a sounder type device is allocated to slot 256 on the control panel. It is therefore recommended that on each control panel a sounder type device which is in close vicinity to the control panel (between 5-10 metres away) is allocated to slot 256.

The additional monitoring incorporates a silent sounder command to be transmitted and an acknowledgement command signal to then be received by the control panel. If the acknowledgement command is not successfully received at the control panel a sounder test fail fault will be displayed for device 256 on the associated control panel.

If this type of fault does occur then checks should be carried out on the system in relation to the operation of sounder type devices.

**18. Fault List**

<b>Panel Faults</b>	<b>Description In Log</b>	<b>Symptom</b>
<b>MN</b>	<b>Mains Input Failed.</b>	<b>Check 230 volt supply and the fuse.</b>
<b>BT</b>	<b>Battery Charging Fail.</b>	<b>Check the battery connection and the fuse.</b>
<b>AT</b>	<b>Main Receiver, Aerial Tamper.</b>	<b>Occurs when one of the aerials have been removed. Check 4k7 resistance that monitors the connections on the aerials.</b>
<b>RI</b>	<b>Radio Interference</b>	<b>Check the radio interference threshold. If level seen is higher than threshold, then there is excessive interference in the air and the cause will have to be identified.</b>
<b>OL</b>	<b>Node Offline</b>	<b>Occurs when one of the networked panels fails to communicate between the master and vice versa. Check the Lan module is on online also check connections, try re-on lining the node from slave and master.</b>
<b>CK</b>	<b>Checksum Changed</b>	<b>Check the checksum is set to logged in the panel hardware menu, reset the checksum data in the main menu.</b>
<b>PR</b>	<b>Processor Reset</b>	<b>Silence and reset fault with the control key switch in the "ON" position. (This happens when the panel is restarted).</b>
<b>T/X</b>	<b>UHF Txer Failed Health Check</b>	<b>Occurs when the radio board is not communicating to the charger relay board. Check the ribbon Cables on radio pcb. Check the pager port is not redirected.</b>
<b>Tamper</b>	<b>In To Tamper</b>	<b>Check the device or unit to ensure it has not been tampered with. Check the tamper switches are closed and making good contact.</b>
<b>H/W Bus node offline</b>	<b>H/W Bus Node Offline</b>	<b>Occurs when hardwired units lose communication with the panel, Check the RS485 bus connections on panel and module. Try restarting the RS 485 bus.</b>
<b>Fire</b>	<b>Into Fire</b>	<b>A device has activated.</b>
<b>Test Alarm</b>	<b>Into Test Alarm</b>	<b>This occurs when a device has been activated whilst the device/zone has been placed into test.</b>
<b>Fault</b>	<b>Head Missing</b>	<b>Occurs when a device head has been removed.</b>
<b>Fault</b>	<b>A Supply Management</b>	<b>Occurs when a fault is found on the batteries on a device. (Low voltage).</b>
<b>Fault</b>	<b>B Supply Management</b>	<b>Occurs when a fault is found on the batteries on a device. (Low voltage).</b>
<b>Fault</b>	<b>C Supply Management</b>	<b>This occurs when a fault is found on the batteries on a device. (Battery missing).</b>
<b>Fault</b>	<b>Intermittent Device Signal</b>	<b>Occurs when the device has not called in within the call in time period. Double basing the unit or moving the VHF high gain aerial to a better position may aid signal.</b>
<b>Fault</b>	<b>New Head</b>	<b>Occurs when a new Sensor head has been inserted on the base or the sensitivity settings have been change.</b>
<b>Fault</b>	<b>No ACK Received</b>	<b>Occurs when an acknowledgement signal has not been received from a device after a command has been sent from the panel to a device. Take the device to the panel and try sending another command to test the transmitter and the receiver.</b>
<b>Fault</b>	<b>Radio Lan Node: 2 (Off-Line)</b>	<b>Occurs when one of the networked panels fails to communicate the master and viseversa. Check the Lan module is on online, try re-on lining the node from slave and master.</b>
<b>Fault</b>	<b>Open Circuit</b>	<b>Occurs when a monitored circuit has been opened.</b>
<b>Fault</b>	<b>Short Circuit</b>	<b>Occurs when a monitored circuit is shorted.</b>
<b>Fault</b>	<b>Condition Ready</b>	<b>Occurs when a monitored circuit is back in normal state.</b>
<b>Fault</b>	<b>Sounder Test Fail</b>	<b>Occurs when either an individual sounder test command is sent to a device and the unit fails to sound or if displayed for device 256 (see section 17).</b>

## **19. Do's and Don'ts**

Don't place any aerials near metal work and keep aerials 2 meters away from all electrical equipment, all tips of aerials must stay away from any obstruction.

Always pinch and twist on helical aerials to ensure good connection.

Always make sure the correct aerial is on the right side of the panel by matching the coloured bands of the aerial to the colours on the panel.

When testing devices, always put the zones into test so sounders are not activated.

Don't change device zones with the fire LED display lit.

Don't warm start the panel to clear device faults.

Always look in the event log for fault description.

Always take the system off watch before testing devices or activating the system.

Always, warm start the panel after entering a TSA set-up to refresh the panel.

Always use industry standard fire rated cable, all screened cable should only be earthed at one end.

Always put lithium-based devices into test, or their zones into test, when changing their battery packs, as new battery information is not recognised when the device is disabled.

Always enable the tamper when logging on a combined detector/sounder.







  <p><b>EMS Group Head Office</b> Technology House, Sea Street Herne Bay, Kent CT6 8JZ England Tel: +44 (0) 8712 710804 Fax: +44 (0) 1227 369679 Email: <a href="mailto:enquiries@msgroup.co.uk">enquiries@msgroup.co.uk</a> <a href="http://www.msgroup.co.uk">www.msgroup.co.uk</a></p>	 <p>Fire Industry Association</p>  <p>bsia british security industry association</p> <p>An <b>ISO 9001:2008</b> Approved Company</p>  	<p><b>Dealer Information:</b></p> <p>The information contained within this literature is correct at time of publishing. The EMS Group reserves the right to change any information regarding products as part of its continual development enhancing new technology and reliability. The EMS Group advises that any product literature issue numbers are checked with its head office prior to any formal specifications being written.</p>
---	--	---