

USER GUIDE  
UGC033-0194

# Dust Collector

## Sizes DC1 and DC2



**INTRODUCTION** • Purpose of the User Guide • How the guide is organized • Using the Dust Collector • Your Responsibility as a User • **ATTENTION:** Read this so no one gets hurt • **DESCRIPTION** • What is the Dust Collector? • Specifications: Dust Collector DC1 and DC2 • **INSTALLATION** • Preparing For Installation - Location • Mounting • Optional Mounting • Vacuum Line Connections • Dust Return Line Connection • Compressed Air Connections • Electrical Connections • **OPERATION** • Manual Unload Type • Automatic Unload/Reload Type • **MAINTENANCE** • Filter Chamber • Collection Chamber • **TROUBLESHOOTING** • Before Beginning • A Few Words of Caution • Troubleshooting

Please record your equipment's model and serial number(s) and the date you received it in the spaces provided.

It's a good idea to record the model and serial number(s) of your equipment and the date you received it in the User Guide. Our service department uses this information, along with the manual number, to provide help for the specific equipment you installed.

Please keep this User Guide and all manuals, engineering prints and parts lists together for documentation of your equipment.

Date:

---

Manual Number: UGC033-0194

---

Serial Number(s):

---

Model Number(s):

---

**DISCLAIMER:** The Conair Group, Inc., shall not be liable for errors contained in this User Guide or for incidental, consequential damages in connection with the furnishing, performance or use of this information. Conair makes no warranty of any kind with regard to this information, including, but not limited to the implied warranties of merchantability and fitness for a particular purpose.

# Table of Contents

## 1-1 Introduction

Purpose of the user guide . . . . .	1-2
How the guide is organized . . . . .	1-2
Using the Dust Collector . . . . .	1-3
Your responsibilities as a user . . . . .	1-3
ATTENTION: Read this so no one gets hurt . . . . .	1-4

## 2-1 Description

What is the Dust Collector? . . . . .	2-2
Specifications: Dust Collector DC1 and DC2 . . . . .	2-3

## 3-1 Installation

Preparing for installation - Location . . . . .	3-2
Installation . . . . .	3-2
Mounting . . . . .	3-2
Optional mounting . . . . .	3-2
Vacuum line connections . . . . .	3-3
Dust return line connection . . . . .	3-4
Compressed air connections . . . . .	3-5
Electrical connections . . . . .	3-5

## 4-1 Operation

Manual unload type . . . . .	4-2
Automatic unload/reload type . . . . .	4-2

## **5-1** Maintenance

Filter Chamber .....	5-2
Collection Chamber.....	5-2

## **6-1** Troubleshooting

Before Beginning.....	6-2
Before you begin troubleshooting .....	6-2
A few words of caution .....	6-2
Troubleshooting.....	6-3

## **A** Appendix

We're here to help .....	A-1
How to contact customer service .....	A-1
Before you call... ..	A-1
Equipment guarantee .....	A-2
Performance warranty .....	A-2

# Introduction

---

Purpose of the user guide. . . . . 1-2

How the guide is organized. . . . . 1-2

Using the Dust Collector. . . . . 1-3

Your responsibilities as a user. . . . . 1-3

ATTENTION:

    Read this so no one gets hurt . . . . . 1-4

## Purpose of the User Guide

This User Guide describes the Conair Dust Collector and explains step-by-step how to install, operate, maintain and repair this equipment.

Before installing this product, please take a few moments to read the User Guide and review the diagrams and safety information in the instruction packet. You also should review manuals covering associated equipment in your system. This review won't take long, and it could save you valuable installation and operating time later.

## How the Guide is Organized

Symbols have been used to help organize the User Guide and call your attention to important information regarding safe installation and operation.



Symbols within triangles warn of conditions that could be hazardous to users or could damage equipment. Read and take precautions before proceeding.

- 1** Numbers indicate tasks or steps to be performed by the user.
- ◆ A diamond indicates the equipment's response to an action performed by the user.
- ☐ An open box marks items in a checklist.
- A circle marks items in a list.
- ◆♦ Indicates a tip. A tip is used to provide you with a suggestion that will help you with the maintenance and the operation of this equipment.
-  Indicates a note. A note is used to provide additional information about the steps you are following throughout the manual.

## Using the Dust Collector

Each dust collector is designed to work within a central vacuum system consisting of:

- Vacuum receiver/loader
- PD Pump(s) or RG Pump(s)
- Central loading control(s)

Separate instructions are provided for these devices and should be referred to as needed to fully understand the operation of the entire system.

## Your Responsibility as a User

You must be familiar with all safety procedures concerning installation, operation and maintenance of this equipment. Responsible safety procedures include:

- Thorough review of this User Guide, paying particular attention to hazard warnings, appendices and related diagrams.
- Thorough review of the equipment itself, with careful attention to voltage sources, intended use and warning labels.
- Thorough review of instruction manuals for associated equipment.
- Step-by-step adherence to instructions outlined in this User Guide.

## ATTENTION:

### Read this so no one gets hurt

We design equipment with the user's safety in mind. You can avoid the potential hazards identified on this machine by following the procedures outlined below and elsewhere in the User Guide.



**WARNING: Improper installation, operation, or servicing may result in equipment damage or personal injury.**

This equipment should be installed, adjusted, and serviced by qualified technical personnel who are familiar with the construction, operation, and potential hazards of this type of machine.

All wiring, disconnects, and fuses should be installed by qualified electrical technicians in accordance with electrical codes in your region. Always maintain a safe ground. Do not operate the equipment at power levels other than what is specified on the machine serial tag and data plate.



**WARNING: Voltage hazard**

This equipment is powered by single-phase alternating current, as specified on the machine serial tag and data plate.



**CAUTION: Wear eye protection**

If you use compressed air to clean the equipment, **you must wear eye protection** and observe all OSHA and other safety regulations pertaining to the use of compressed air.



# Description

---

What is the Dust Collector? . . . . . 2-2

Specifications: Dust Collector

    DC1 and DC2 . . . . . 2-3

## What is the Dust Collector?

Conair Dust Collectors keep your plant free of air-borne dust and fines and prevent dust from fouling the vacuum pump.

A central vacuum dust collector allows dust filtration to take place at floor level. An air-tight collection container makes the removal of fines quick and easy.

Automatic filter cleaning is standard, lengthening the time between service requirements. DC1 and DC2 models use an integrated “popper valve” to remove dust from the filter.

A dust collector system consists of four sections:

- **Floor stand mounting frame.**
- **Filter chamber** - This contains the cartridge filter, vacuum valve and solenoid. The filter chamber is typically bolted to the floor stand, but can be mounted to a wall, pump base, etc.
- **Three-way vacuum breaker valve** - This valve is mounted within the filter section. During conveying it is closed to ambient air. At the end of a conveying cycle the valve will open allowing ambient air to flow into the dust collector’s internal filter causing a shock-wave effect loosening fines and dust that are trapped within the internal filter, allowing the material to fall into the collection chamber.
- **Collection Chamber** - On a manual dump unit, this will be a removable container for manually emptying the collected dust and fines. On an automatic unload/reload unit, this is a two-chambered device that clamps on in place of the manual dump container. The top section is a conical hopper, with a conical unload valve. The bottom chamber is also conical, containing a take-away tube and a solenoid air vent valve. During the vacuum load cycle, dust is collected in the upper section. At the end of the load cycle, dust is dropped into the bottom takeaway section. When the next load cycle begins, the conical valve closes and the solenoid air vent valve opens, allowing dust to be sucked into the conveying line through a diverter “Y” tube, back into the main receiving hopper. After 5 to 10 seconds, the solenoid valve closes, diverting all air to material in the conveying system.



# Specifications: Dust Collector DC1 and DC2

MODELS	DC1	DC2
<b>Performance Characteristics</b>		
Pump size range Hp {kW} *	3-7.5 {2.2-5.6}	10-25 {7.5-18.7}
Vacuum line size OD in {mm}	1.5-2.5 {38.1-63.5}	2.25-4.0 {57.2-101.6}
Filter area ft <sup>2</sup> {M <sup>2</sup> }	42.8 {4.0}	100.3 {9.3}
Maximum collection capacity ft <sup>3</sup> {liters}	1.1 {31.1}	2.1 {59.4}
Recommended dust collection ft <sup>3</sup> {liters}	0.75 {21.2}	1.0 {28.3}
<b>Dimensions inches {cm}</b>		
A - Height	58.0 {147.3}	67.0 {170.1}
B - Width	15.0 {38.1}	19.0 {48.3}
Depth	20.0 {50.8}	19.0 {48.3}
<b>Weight lb {kg}</b>		
Installed	110 {49.9}	150 {68.0}
Shipping	140 {63.5}	280 {127.0}
<b>Voltage total amps</b>		
120V/1 phase/60Hz	1.0	1.0
<b>Compressed air requirement</b>		
	80-120 psi {5.5-8.3 bars}	

<b>SPECIFICATION NOTES:</b>	
* Model DC1 works with Conair pump models RG-1-3, RG1-6, PD3, PD5, and PD7.5.	
Model DC2 works with RG1-11, RG2-16, PD10, PD15 and PD25.	
Specifications can change without notice. Check with a Conair representative for the most current information.	

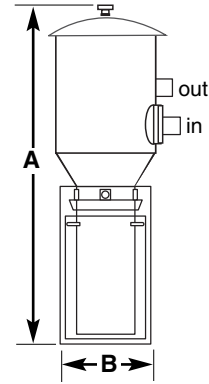

Model DC1 and DC2



# Installation

---

Preparing for installation - Location . . . . . 3-2  
Installation . . . . . 3-2  
    Mounting . . . . . 3-2  
    Optional Mounting . . . . . 3-2  
    Vacuum Line Connections . . . . . 3-3  
    Dust Return Line Connection . . . . . 3-4  
    Compressed Air Connections . . . . . 3-5  
    Electrical Connections . . . . . 3-5



**WARNING:** You are responsible for the structural integrity of this installation.

## Preparing for Installation - Location

When using the manual dump type dust collector, it is best located near the vacuum pump. When using the automatic unload/reload dust collector, it is better to locate it near the loader that is receiving the dust.

If neither location is convenient, then locate the dust collector anywhere along the vacuum line between the loader and pump assembly.

## Installation Mounting

Supplied as standard is a free standing frame to which the filter and collection chambers are bolted.

### Optional Mounting

The dust collector may be mounted by the filter chamber to a wall, material storage bin, pump base assembly or any number of other desired places.

**IMPORTANT:** The unit MUST be mounted in a vertical position to obtain proper dust separation and filtration.

## Installation (continued)

### Vacuum Line Connections

The vacuum line from the loader connects to the central separating section tangential entry tube. The vacuum line to the pump connects to the 3-way vacuum breaker valve which is installed in the center of the filter chamber.

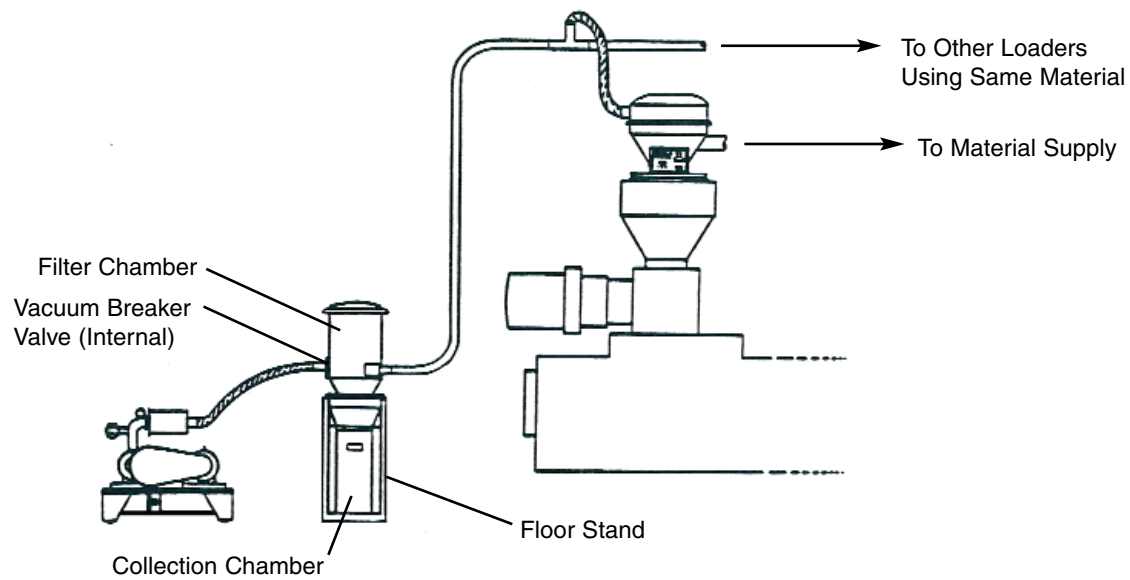

 **NOTE:** Vacuum pump shown above is 180° out of position.

## Installation (continued)

### Dust Return Line Connection

For the automatic unload/reload type dust collectors, a “Y” diverter tube is included and should be installed as close as possible to the main material loader. Horizontal positioning of the “Y” diverter tube is best. The dust return line is a 1.5 inches {38.1 mm} OD tubing and should be installed rigidly from the “Y” diverter tube back to the bottom take-away section of the dust collector, where the connection should be made with a 2-3 ft {61-91 cm} section of flex hose.

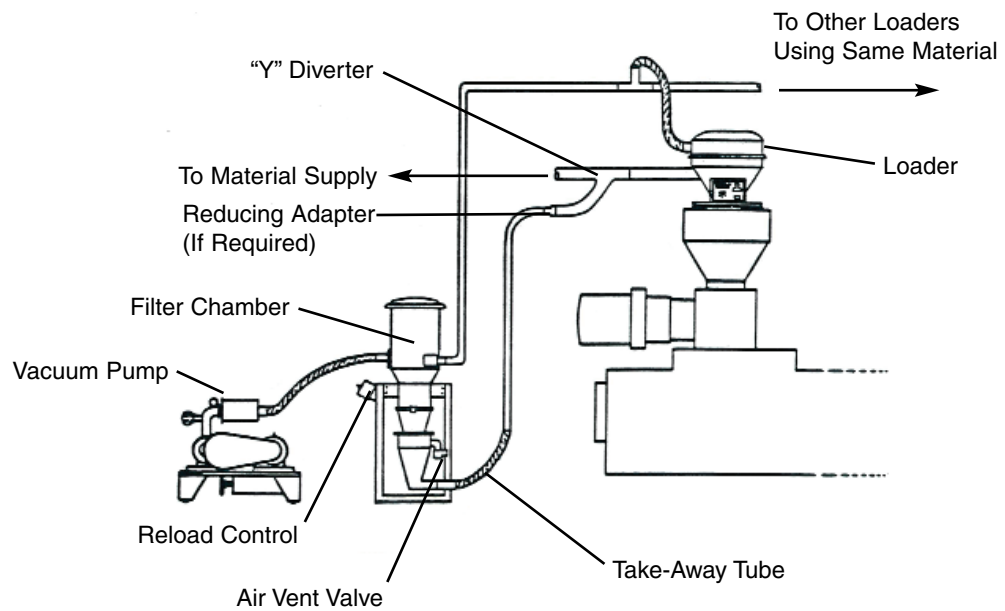



## Installation (continued)

### Compressed Air Connections

Connect a compressed air line (80-100 psi) to the inlet of the solenoid valve which is located on the mounting plate of the filter chamber. An air line is connected from the solenoid to the vacuum breaker valve within the filter chamber. If the automatic unload/reload section is used, a line will also be ran to the solenoid valve mounted on the outside of the reload control. Compressed air must be filtered free of moisture. Automatic unload/reload units come equipped with compressed air filters.

**DO NOT** connect compressed air to the 0.75 in. {19.05 mm} solenoid air vent located on the bottom section of the automatic unload/reload dust collector.

### Electrical Connections

Proper operation of the dust collector depends upon its internal vacuum valve opening whenever the vacuum pump is energized. Electrical connections are provided by a 3-conductor cable connected to the dust collector. This cable should be connected to the vacuum pump control enclosure to provide simultaneous operation of the dust collector when the pump is activated. On automatic unload/reload dust collectors, the cable is attached to the reload control enclosure, which distributes power to the various solenoids for the auto reload function of the dust collector.



**IMPORTANT:** Always refer to the wiring diagrams that came with your equipment to locate specific electrical components. Illustrations and photographs in the User Guide are intended only to be representative only.



# Operation

---

Manual Unload Type . . . . . 4-2  
Automatic Unload/Reload Type . . . . . 4-2

## Manual Unload Type

The internal 3-way vacuum valve is energized simultaneously with the vacuum pump. This allows a vacuum to be drawn through the dust collector, tubing and loader, starting the conveying cycle. During the conveying cycle, dust laden air enters the filtering section of the dust collector and the dust is separated from the air stream tangentially. This dust is deposited in the manual dump container below the filter chamber.

**IMPORTANT:** The bottom collection container needs to be emptied periodically and not allowed to overflow. This can cause dust to back up into the top filter section of the dust collector causing ineffective separation and premature clogging of the internal filter.

At the end of the load cycle, the 3-way vacuum valve is de-energized closing off the vacuum line and venting into the atmosphere. This causes a reverse flow of atmospheric air to rush through the internal cartridge filter. Fines and dust trapped during the conveying cycle are blown off the filter before the next conveying cycle begins.

## Automatic Unload/Reload Type

Automatic unload/reload type dust collectors consist of two conical sections clamped to the collector plate of the manual dump container. The upper chamber is a small conical receiver containing an air operated conical valve at its base. The lower chamber contains a take-away and air vent valve. The 3-way vacuum breaker valve operation is the same as described for manual collectors.

At the beginning of the load cycle, the timer, located in the dust collector control box is energized, opening the air vent valve. This timer should be set for 5-10 seconds. During this time, dust, deposited in the lower chamber from the previous cycle, is conveyed back to the loader through the “Y” diverter tube (*See Installation Section entitled, Dust Return Line Connection*). At the end of 5-10 seconds, the air vent valve closes, diverting 100% vacuum to the main material flow. During the rest of the vacuum load cycle, dust is deposited in the upper section. At the end of the load cycle, this dust is dumped through the conical valve into the take-away section. When the vacuum pump is energized the conical valve closes and the solenoid air vent opens and the load cycle is repeated.

When an auto unload/reload type dust collector is installed in a multiple loader conveying system, it is very important to note that the loader’s filter receiving the carryover dust from the dust collector will accumulate dust to the point of clogging its internal filter. To prevent this from happening, the bottom auto unload/reload chambers of the dust collector should be replaced with a manual dump container to collect the separated dust. The manual dump container will require periodic emptying.

# Maintenance

---

Filter Chamber . . . . . 5-2  
Collection Chamber . . . . . 5-2

## Filter Chamber

Located within the filter chamber is a dry cartridge type filter. Regular filter servicing is required. Time between servicing depends on the pound/hour capacity of the loading system and the type of material used. Some indications of when to clean or change a filter are an increase in the normal conveying vacuum, surging or line blockage or a significant increase in load time (by 20 seconds or more).

Servicing should include a check of the rubber gaskets, all vacuum connections and cleaning the filter element:

### 1 Clean the filter by laying it on its side and gently tapping it on the floor.

Then, use a vacuum cleaner to remove the loosened dust.



**CAUTION: Wear eye protection.** If you use compressed air to clean the equipment, **you must wear eye protection** and observe all OSHA and other safety regulations pertaining to the use of compressed air.

### 2 Inspect the paper element of the filter for damage, holes, etc... before re-installing. *For replacement filters - See Spare parts list.*

### 3 Reinstall the filter.

## Collection Section

**Manual Dump** - It is extremely important that this container does not overflow, as dust will back up into the separating section and clog the cartridge filter. Daily emptying, or as required, will prevent this. Make sure the seal is in place when re-installing the container.

**Automatic Unload/Reload** - Since this unit is designed to unload dust from the dust collector automatically with each loader cycle, it is only important to check these two chambers periodically for residue build-up that might block off the conical valve discharge area or take-away tube. Take apart and clean with compressed air or vacuum cleaner. When re-assembling, check that the gaskets and seals are in place.

**Replacement filters are available from Conair.**

Contact Conair Parts  
(800) 458 1960  
From outside of the  
United States, call:  
(814) 437 6861

# Troubleshooting

---

Before Beginning . . . . .	6-2
Before you begin troubleshooting . . . . .	6-2
A few words of caution . . . . .	6-2
Troubleshooting . . . . .	6-3

## Before Beginning

You can avoid most problems by following the recommended installation and maintenance procedures outlined in this User Guide. If you do have a problem, this section will help you determine what caused it and how to fix it.

### Before you begin troubleshooting:

- ❑ **Find the wiring diagrams that were shipped with your equipment.**  
These diagrams are the best reference for correcting a problem. The diagrams also will note any custom features, such as special wiring or control options, not covered in this User Guide.
- ❑ **Verify that you have manuals for other equipment in the process line.**  
Solving problems may require troubleshooting malfunctions or incorrect operating procedures on other pieces of equipment.

### A Few Words of Caution



**WARNING:** This machine should be adjusted and serviced only by qualified technical personnel who are familiar with construction and operation of this type of equipment.



**WARNING: Voltage hazard.**

Troubleshooting the electrical system of this equipment requires use of precision electronic measuring equipment, and may require access to the electrical enclosure while power is on. Exposure to potentially harmful voltage levels may be unavoidable. These troubleshooting procedures should be performed only by qualified electrical technicians who know how to use this precision electronic equipment and who understand the hazards involved.



**WARNING: Disconnect power and compressed air before servicing.**

Always disconnect and lock out power and compressed air supplied to this equipment before performing maintenance or repair. Failure to do so could result in personal injury caused by the unexpected energization of this equipment.



**CAUTION: Wear eye protection.**

If you use compressed air to clean the equipment, **you must wear eye protection** and observe all OSHA and other safety regulations pertaining to the use of compressed air.

**Replacement filters are available from Conair.**

Contact Conair Parts  
(800) 458 1960  
From outside of the  
United States, call:  
(814) 437 6861



# Troubleshooting

Problem	Possible cause	Solution
<b>Sluggish conveying, excessive load time, higher than normal conveying vacuums.</b>	The internal filter is clogged.	Clean internal filter, replace as necessary.
<b>Excessive load time, low vacuum.</b>	Vacuum leak in material, vacuum or dust return lines.	Seal "O" ring couplings, check hose clamps.
	3-way vacuum valve is leaking.	Increase air pressure 80-100 psi, clear obstructions.
<b>Excessive filter clogging.</b>	3-way vacuum valve is inoperative or ineffective.	Check air pressure; is solenoid valve energizing? Are conveying vacuums in the 10-12" Hg. range?
	Excessive dust carryover from loader.	<i>See Troubleshooting Section in the loader's manual.</i>
<b>Clogged separating section.</b>	Build-up of dust in collector container.	Empty container and clean filter.
	Build-up of dust in automatic take-away section.	Disassemble both bottom sections, clean as necessary.
<b>Build-up of dust in bottom two sections of automatic unload/reload type dust collector.</b>	Vent air solenoid failure.	Check for 110 volt signal, check diaphragm for dirt, clean and reassemble valve.
	Timer failure.	Check electrical circuit, increase unload time.

Additional manuals and prints for your Conair equipment may be ordered through the Customer Service or Parts Department for a nominal fee. Most manuals can be downloaded free of charge from the product section of the Conair website.  
[www.conairgroup.com](http://www.conairgroup.com)

## We're Here to Help

Conair has made the largest investment in customer support in the plastics industry. Our service experts are available to help with any problem you might have installing and operating your equipment. Your Conair sales representative also can help analyze the nature of your problem, assuring that it did not result from misapplication or improper use.

## How to Contact Customer Service

To contact Customer Service personnel, call:



 **NOTE:** Normal operating hours are 8:00 am - 5:00 pm. After hours emergency service is available at the same phone number.

You can commission Conair service personnel to provide on-site service by contacting the Customer Service Department.

## Before You Call...

If you do have a problem, please complete the following checklist before calling Conair:

- Make sure you have all model, control type and serial numbers from the serial tag, and parts list numbers for your particular equipment. Service personnel will need this information to assist you..
- Make sure power is supplied to the equipment.
- Make sure that all connectors and wires within and between control systems and related components have been installed correctly.
- Check the troubleshooting guide of this manual for a solution.
- Thoroughly examine the instruction manual(s) for associated equipment, especially controls. Each manual may have its own troubleshooting guide to help you.
- Check that the equipment has been operated as described in this manual.
- Check accompanying schematic drawings for information on special considerations.

## Equipment Guarantee

Conair guarantees the machinery and equipment on this order, for a period as defined in the quotation from date of shipment, against defects in material and workmanship under the normal use and service for which it was recommended (except for parts that are typically replaced after normal usage, such as filters, liner plates, etc.). Conair's guarantee is limited to replacing, at our option, the part or parts determined by us to be defective after examination. The customer assumes the cost of transportation of the part or parts to and from the factory.

## Performance Warranty

Conair warrants that this equipment will perform at or above the ratings stated in specific quotations covering the equipment or as detailed in engineering specifications, provided the equipment is applied, installed, operated and maintained in the recommended manner as outlined in our quotation or specifications.

Should performance not meet warranted levels, Conair at its discretion will exercise one of the following options:

- Inspect the equipment and perform alterations or adjustments to satisfy performance claims. (Charges for such inspections and corrections will be waived unless failure to meet warranty is due to misapplication, improper installation, poor maintenance practices or improper operation.)
- Replace the original equipment with other Conair equipment that will meet original performance claims at no extra cost to the customer.
- Refund the invoiced cost to the customer. Credit is subject to prior notice by the customer at which time a Return Goods Authorization Number (RGA) will be issued by Conair's Service Department. Returned equipment must be well crated and in proper operating condition, including all parts. Returns must be prepaid.

Purchaser must notify Conair in writing of any claim and provide a customer receipt and other evidence that a claim is being made.

## Warranty Limitations

**Except for the Equipment Guarantee and Performance Warranty stated above, Conair disclaims all other warranties with respect to the equipment, express or implied, arising by operation of law, course of dealing, usage of trade or otherwise, including but not limited to the implied warranties of merchantability and fitness for a particular purpose.**