

TMS320DM368 ***Evaluation Module***

*Technical
Reference*

TMS320DM368 Evaluation Module Technical Reference

514565-0001 Rev. B
March 2011

SPECTRUM DIGITAL, INC.
12502 Exchange Drive, Suite 440 Stafford, TX. 77477
Tel: 281.494.4505 Fax: 281.494.5310
sales@spectrumdigital.com www.spectrumdigital.com

IMPORTANT NOTICE

Spectrum Digital, Inc. reserves the right to make changes to its products or to discontinue any product or service without notice. Customers are advised to obtain the latest version of relevant information to verify that the data being relied on is current before placing orders.

Spectrum Digital, Inc. warrants performance of its products and related software to current specifications in accordance with Spectrum Digital's standard warranty. Testing and other quality control techniques are utilized to the extent deemed necessary to support this warranty.

Please be aware that the products described herein are not intended for use in life-support appliances, devices, or systems. Spectrum Digital does not warrant nor is Spectrum Digital liable for the product described herein to be used in other than a development environment.

Spectrum Digital, Inc. assumes no liability for applications assistance, customer product design, software performance, or infringement of patents or services described herein. Nor does Spectrum Digital warrant or represent any license, either express or implied, is granted under any patent right, copyright, or other intellectual property right of Spectrum Digital, Inc. covering or relating to any combination, machine, or process in which such Digital Signal Processing development products or services might be or are used.

WARNING

This equipment is intended for use in a laboratory test environment only. It generates, uses, and can radiate radio frequency energy and has not been tested for compliance with the limits of computing devices pursuant to subpart J of part 15 of FCC rules, which are designed to provide reasonable protection against radio frequency interference. Operation of this equipment in other environments may cause interference with radio communications, in which case the user at his own expense will be required to take whatever measures necessary to correct this interference.

Contents

1	Introduction to the DM368 Evaluation Module	1-1
	<i>Provides you with a description of the DM368 Evaluation Module, key features, and block diagram.</i>	
1.1	Key Features	1-2
1.2	Functional Overview of the DM368 EVM	1-5
1.3	Basic Operation	1-5
1.4	Memory Map	1-6
1.5	Boot / Configuration Switch Settings	1-7
1.6	Power Supply	1-8
1.7	DM368 User Interface Module with Touch Screen	1-8
1.7.1	DM368 UIM Installation on DM368 EVM Checklist	1-9
1.7.2	Removal of UIM from DM368 EVM Checklist	1-10
2	Board Components	2-1
	<i>Describes the operation of the major board components on the DM368 Evaluation Module.</i>	
2.1	EMIF Interfaces	2-2
2.1.1	Flash, NAND Flash	2-2
2.1.1.1	One NAND	2-2
2.1.1.2	CPLD Interface	2-4
2.1.1.2.1	Register 0, CPLD Version	2-6
2.1.1.2.2	Register 1, Test Register	2-6
2.1.1.2.3	Register 2, LED Register	2-6
2.1.1.2.4	Register 3, Board Mux Control Register	2-6
2.1.1.2.5	Register 4, Board Switch Register	2-7
2.1.1.2.6	Register 5, Power Control Register	2-7
2.1.1.2.7	Register 6, GPIO Video Register	2-8
2.1.1.2.8	Register 7, Media Card Status	2-9
2.1.1.2.9	Register 8, DILC Output Pin Mapping	2-9
2.1.1.2.10	Register 9, DILC Input Pin Mapping	2-10
2.1.1.2.11	Register 10, Imager Internal I/O Direction Register 0	2-10
2.1.1.2.12	Register 11, Internal I/O Mux Register 0	2-11
2.1.1.2.13	Register 12, Internal I/O Mux Register 1	2-11
2.1.1.2.14	Register 13, Imager Internal I/O Direction Register 1	2-12
2.1.1.2.15	Register 14, Imager Internal I/O Mux Register 2	2-12
2.1.1.2.16	Register 15, Imager Internal I/O Mux Register 3	2-13
2.1.1.2.17	Register 16, Imager Internal I/O Direction Register 2	2-13
2.1.1.2.18	Register 17, Imager Internal I/O Mux Register 4	2-14
2.1.1.2.19	Register 18, Imager Internal I/O Mux Register 5	2-14
2.1.1.2.20	Imager Multiplexer Mapping	2-15
2.1.1.2.21	Register 19, Board RESET/EXTCLK Select Register	2-17
2.1.1.2.22	Register 20, Interrupt Select Register	2-18

2.1.1.2.23	Register 720, CCD Internal I/O Direction Register 1	2-18
2.1.1.2.24	Register 721, CCS Internal I/O Read/Write Register 1	2-19
2.1.1.2.25	Register 722, CCD Internal I/O Direction Register 2	2-19
2.1.1.2.26	Register 723, CCD Internal I/O Read/Write Register 2	2-20
2.1.1.2.27	Register 724, CCD Internal I/O Direction Register 3	2-20
2.1.1.2.28	Register 725, CCD Internal I/O Read/Write Register 3	2-21
2.1.1.3	Key Pad Interface	2-21
2.1.2	DDR2 Memory Interface	2-22
2.1.3	Media Card Interface	2-22
2.1.4	UART Interface	2-22
2.1.5	USB Interface	2-22
2.2	Input Video Port/Imager Input Port Interfaces	2-23
2.2.1	On Chip Video Output DAC	2-23
2.2.2	LCD Video Connectors	2-23
2.3	AIC3101 Interface	2-24
2.4	On Chip Voice Codec	2-25
2.5	On Chip ADC	2-25
2.6	On Chip RTC	2-25
2.7	Ethernet Interface	2-26
2.8	I ² C Interface	2-26
2.8.1	MSP430	2-27
2.9	Daughter Card Interface	2-27
2.10	DM368 CPU Video Clocks	2-27
2.11	Battery	2-28
3	Physical Specifications	3-1
	<i>Describes the physical layout of the DM368 Evaluation Module and its connectors.</i>	
3.1	Board Layout	3-3
3.2	Connectors	3-5
3.2.1	J1, MiniAB USB Connector and Jumpers	3-6
3.2.2	J2, 14 Pin External JTAG Header	3-7
3.2.3	J3, MSP430 JTAG Header	3-8
3.2.4	J4, Spare Jumper Holder	3-8
3.2.5	J5, 20 Pin ARM JTAG Emulation Header	3-9
3.2.6	J6, USB Capacitance Select	3-9
3.2.7	J7, +5 Volts Input	3-10
3.2.8	J12, SD/MMC/MS Card Interface	3-10
3.2.9	J10, Imager Interface	3-11
3.2.10	J14, EMIF/UPI DC Interface	3-12
3.2.11	J8, Y Component Video In, RCA Jack (Green)	3-13
3.2.12	J9, Pb Component Video In, RCA Jack (Blue)	3-13
3.2.13	J11, Pr Component Video In, RCA Jack (Red)	3-14
3.2.14	J15, S-Video In	3-14
3.2.15	J13, CVBS/Y Input, RCA Jack (Yellow)	3-15
3.2.16	J16, Composite TV Out, RCA Jack (Yellow)	3-15
3.2.17	J17, Y Component Video Out, RCA Jack (Green)	3-16
3.2.18	J20, Pb Component Video Out, RCA Jack (Blue)	3-16
3.2.19	J21, Pr Component Video Out, RCA Jack (Red)	3-17
3.2.20	J18, J19, Video Output DC	3-18
3.2.21	J22, CPLD Programming Header	3-19

3.2.22	J23, I/O Interface Header	3-19
3.2.23	J24, DILC Host Connector	3-20
3.2.24	J25, MMC/SD Connector	3-21
3.2.26	P1, RS-232 UART	3-22
3.2.27	P2, Ethernet Interface	3-23
3.2.28	P3, Microphone In	3-24
3.2.29	P4, Line In	3-24
3.2.30	P5, Line Out	3-25
3.2.31	P6, Headphone Out	3-25
3.2.32	U1, Infrared Interface	3-26
3.2.33	SPK1, Speaker Interface	3-26
3.2.34	BHT1, Battery Interface	3-27
3.2.35	M1, Microphone Interface	3-27
3.3	LEDs	3-28
3.4	Switches	3-29
3.4.1	SW1, EMU0/1 Select Switch	3-30
3.4.2	SW2, PWCTRO0 Pushbutton	3-30
3.4.3	SW3, RESET Pushbutton	3-30
3.4.4	SW4, Boot Mode / Configuration Select	3-31
3.4.5	SW5, Board Configuration Select	3-32
3.4.6	SW6 - SW21, Function Pushbuttons	3-32
3.4.7	SW22, MSP430 IO0 Pushbutton	3-33
3.4.8	SW23, PRTSC Mode Select	3-33
3.5	Jumpers	3-34
3.5.1	JP1, Jumper Block	3-34
3.5.2	JP2, Unpopulated Jumper	3-34
3.5.3	JP28, Unpopulated Jumper	3-34
3.5.4	J26, USB ID Select	3-34
3.5.5	J27, U14 LL8 Voltage Select	3-34
3.6	Test Points	3-35
A	Schematics	A-1
	<i>Contains the schematics for the DM368 Evaluation Module</i>	
B	Mechanical Information	B-1
	<i>Contains the mechanical information about the DM368 Evaluation Module</i>	

About This Manual

This document describes the board level operations of the DM368 Evaluation Module (EVM). The EVM is based on the Texas Instruments TMS320DM368 Processor.

The DM368 Evaluation Module is a table top card that allows engineers and software developers to evaluate certain characteristics of the DM368 processor to determine if the processor meets the designers application requirements. Evaluators can create software to execute on board or expand the system in a variety of ways.

Notational Conventions

This document uses the following conventions.

The DM368 Evaluation Module will sometimes be referred to as the DM368 EVM or EVM.

Program listings, program examples, and interactive displays are shown in a special italic typeface. Here is a sample program listing.

```
equations  
!rd = !strobe&rw;
```

Information About Cautions

This book may contain cautions.

This is an example of a caution statement.

A caution statement describes a situation that could potentially damage your software, or hardware, or other equipment. The information in a caution is provided for your protection. Please read each caution carefully.

Related Documents, Application Notes and User Guides

Information regarding the TMS320DM368 can be found at the following Texas Instruments website:

<http://www.ti.com>

Table 1: Manual History

Revision	History
A	Beta Release
B	Edits to CPLD registers, Tables

Table 2: Board History

PWB Revision	History
A	Beta Release

Chapter 1

Introduction to the DM368 EVM

Chapter One provides a description of the DM368 EVM along with the key features and a block diagram of the circuit board.

Topic	Page
1.1 Key Features	1-2
1.2 Functional Overview of the DM368 EVM	1-5
1.3 Basic Operation	1-5
1.4 Memory Map	1-6
1.5 Boot / Configuration Switch Settings	1-7
1.6 Power Supply	1-8
1.7 DM368 User Interface Module with Touch Screen	1-8
1.7.1 DM368 UIM Installation on DM368 EVM Checklist	1-9
1.7.2 Removal of UIM from the DM368 EVM Checklist	1-10

- UART Interface
- SD/MMC/MS, MMC/SD Media Card Interfaces
- 2 Gigabytes NAND Flash
- 128 Megabytes of One NAND
- AIC3101 stereo codec
- USB2 Interface
- 10/100 MBS RMII Ethernet Interface
- SPI EEPROM
- IR Remote Interface via MSP430
- Configurable boot load options
- 8 user LEDs/16 user push button switches
- Single voltage power supply (+5V)
- Expansion connectors for daughter card use
- 14 Pin TI JTAG/20 Pin ARM JTAG Interfaces

The two figures below show the DM368 EVM without the display and with the display mounted.

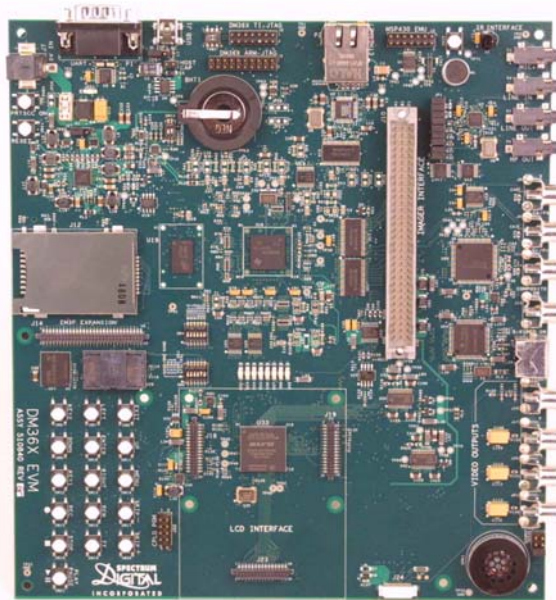

Figure 1-2, DM368 EVM Without DM368 UIM

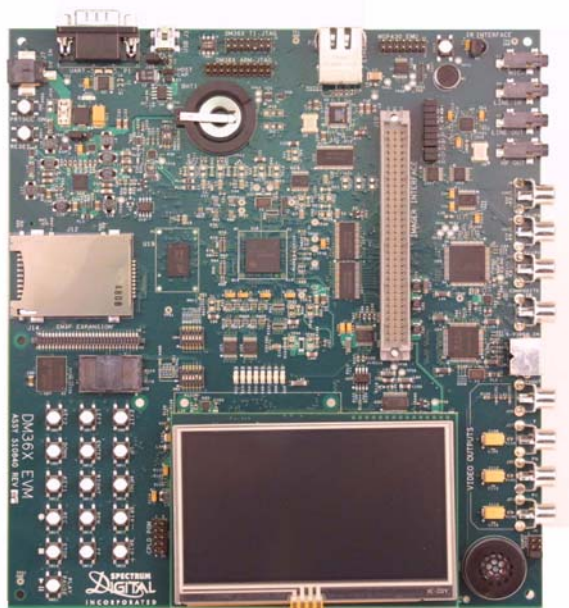

Figure 1-3, DM368 EVM With DM368 UIM

1.2 Functional Overview of the DM368 EVM

The DM368 on the EVM interfaces to on-board peripherals through the 8/16-bit wide Async EMIF peripheral interface pins. The DDR2 memory is connected to its own dedicated 16 bit wide bus. The Async EMIF bus is also connected to the NAND and One NAND flash.

On board video decoders and on chip encoders interface video streams to the DM368 processor. One composite channel and one set of 3 component channel encoder/decoder are standard on the EVM. On screen display functions are implemented in software on the DM368 processor.

An on-board AIC3101 codec allows the DSP to transmit and receive analog audio signals. The I²C bus is used for the codec control interface, while the McBSP controls the audio stream. Signal interfacing is done through 3.5mm audio jacks that correspond to microphone input, headphone output, line input, and line output.

The EVM includes 8 user LEDs, 16 user push button switches, and an IR interface which provide the user with application interaction.

An included +5V external power supply is used to power the board. On-board switching voltage regulators provide the +1.2 to 1.35V CPU core voltage, +3.3V for peripherals and +1.8V for DDR2 memory.

The DM368 EVM has a 10/100 ethernet interface which provides a standard high speed link to other devices.

The on board media card interface allows the user to conveniently load/store data from a variety of standard memory card formats. An on-chip Real Time Clock is integrated into the DM368 for time based applications.

1.3 Basic Operation

The EVM is designed to work with TI's Code Composer Studio IDE[™], or standard GDB tool environments. Code Composer communicates with the board through an external JTAG emulator.

1.4 Memory Map

The DM368 processor has a byte addressable address space. There are some limitations to byte addressing which are determined by peripheral interconnection to the DM368 device. Program code and data can be placed anywhere in the unified address space. Addresses are multiple sizes depending on hardware implementation. Refer to the appropriate device data sheets for more details.

The memory map shows the address space of a generic DM368 processor on the left with specific details of how each region is used on the right. By default, the internal memory sits at the beginning of the address space. Portions of memory can be remapped in software as L2 cache rather than fixed RAM.

The part incorporates a dual EMIF interface. One dedicated EMIF directly interfaces to the DDR2 memory. The other EMIF has 2 separate addressable regions called chip enable spaces (CE0 & CE1). The NAND Flash, one NAND, and CPLD are mapped into these chip enable spaces.

DM368 EVM	
Address	Memory Map Address Space
0x00000000	ARM Instruction RAM
0x00007FFF 0x00008000	ARM Instruction ROM
0x0000BFFF 0x00010000	ARM RAM (Data)
0x00017FFF 0x01C00000	CFG Bus Peripherals
0x01FFFFFF 0x02000000	CE0 - ASYNC EMIF (Data)
0x03FFFFFF 0x04000000	CE1
0x05FFFFFF 0x20000000	DDR EMIF Control Regs
0x2007FFFF 0x80000000	DDR EMIF
0x87FFFFFF 0x88000000	DDR Expansion (reserved)
0x8FFFFFFF	

Figure 1-4, Memory Map, DM368 EVM

Shown below is a break out of the memory spaces.

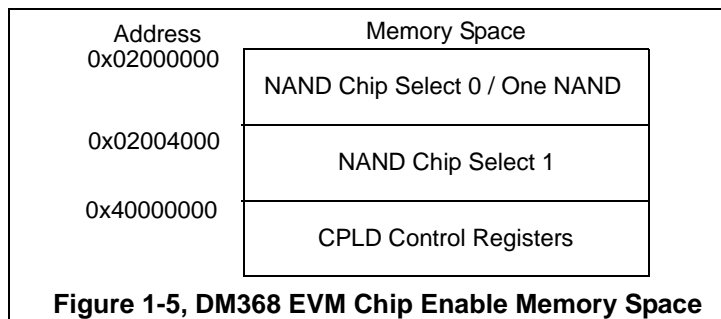

1.5 Boot / Configuration Switch Settings

The EVM has a configuration switch that allow users to control the Boot and EMIF configuration state of the processor when it is released from reset. The switch SW4 determines the source for processor booting. By default the switches are configured to NAND Flash boot. The EMIF configuration switch must be set accordingly. This switch configures the DM368 pin muxing at RESET. The default for the pin muxing is shown below. For additional pin muxing requirements please refer to the D368 data sheet.

Table 1: SW4, ARM Boot Mode Select

Pos 3	Pos 2	Pos 1	HW Code	Boot Mode
ON	ON	ON	0 0 0	NAND Boot *
ON	ON	OFF	0 0 1	ASYNC EMIF
ON	OFF	ON	0 1 0	MMC/SD Boot
ON	OFF	OFF	0 1 1	UART Boot
OFF	ON	ON	1 0 0	USB Boot
OFF	ON	OFF	1 0 1	SPI Boot
OFF	OFF	ON	1 1 0	EMAC Boot
OFF	OFF	OFF	1 1 1	HPI Boot

Table 2: SW4, ARM EMIF Configuration Mode Select

Pos 6	Pos 5	Pos 4	HW Code	Configuration Mode
ON	ON	ON	0 0 0	8-bit AEMIF Configuration *
ON	ON	OFF	0 0 1	16-bit AEMIF Configuration

* default setting

1.6 Power Supply

The EVM operates from a single +5V external power supply connected to the main power input (J7), a 2.5 MM. barrel-type plug. Internally, the +5V input is converted into +1.2 to 1.35V, +1.8V and +3.3V using Texas Instruments TPS65530 power management IC and various linear regulators. The +1.2 to 1.35V supply is used for the DSP core while the +3.3V supply is used for the DSP's I/O buffers and other chips on the board. The +1.8 volt supply is used for DM368 DDR2 memory, and other on chip peripherals.

1.7 DM368 User Interface Module with Touch Screen

The DM368 EVM can be used with the DM368 User Interface Module (UIM) with touch screen. The DM368 UIM plugs on the DM368 EVM and is shown in figure 1-3 above. The table below shows the mating of the connectors on the DM368 EVM to the connectors on the DM368 UIM.

Table 3: DM368 - Mating UIM Connectors

DM368 Connector	Mating UIM Connectors
J18	J2
J19	J1
J23	J6

1.7.1 DM368 UIM Installation on DM368 EVM Checklist

To install the DM368 UIM on the DM368 EVM execute the following checklist:

- o Turn **off** the power to your DM368 EVM !
- o Align connectors J1, J2, and J6 of the UIM with connectors J18, J19, and J23 on the DM368 EVM.

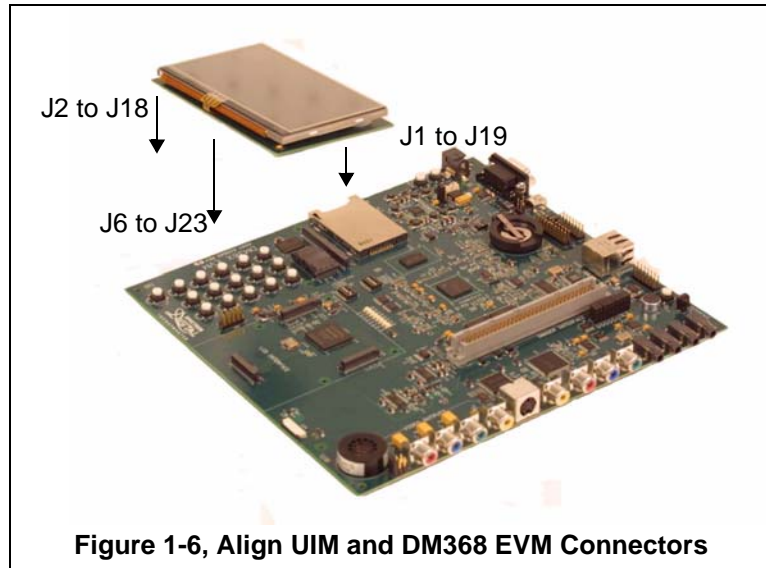

- o Visually inspect the alignment of the connectors from the card edge (Spectrum Digital logo) to insure all 6 connectors are mated together.
- o Carefully push the UIM down onto the DM368 EVM.
- o Turn on the power to your DM368 EVM and verify operation.

1.7.2 Removal of UIM from the DM368 EVM Checklist

To remove the UIM from the DM368 EVM execute the following checklist:

- o Turn **off** the power to your DM368 EVM !
- o Carefully lift the edges of the UIM circuit board up. If necessary rotate lifting from right side, bottom edge, left side, right side, until the UIM is free from the DM368 EVM.

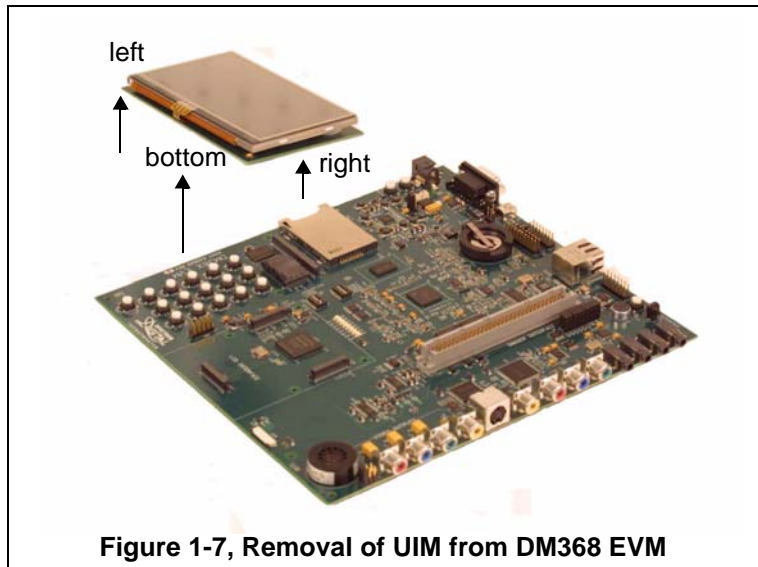

- o Safely store the UIM in an anti-static bag.
- o Turn on the power to your DM368 EVM and verify operation.

Board Components

This chapter describes the operation of the major board components on the DM368 EVM.

Topic	Page
2.1 Asynchronous EMIF Interface	2-2
2.1.1 NAND Flash	2-2
2.1.1.1 One NAND	2-2
2.1.1.2 CPLD Interface	2-4
2.1.1.2.1 Register 0, CPLD Version	2-6
2.1.1.2.2 Register 1, Test Register	2-6
2.1.1.2.3 Register 2, LED Register	2-6
2.1.1.2.4 Register 3, Board Mux Control Register	2-6
2.1.1.2.5 Register 4, Board Switch Register	2-7
2.1.1.2.6 Register 5, Power Control Register	2-7
2.1.1.2.7 Register 6, GPIO Video Register	2-8
2.1.1.2.8 Register 7, Media Card Status	2-9
2.1.1.2.9 Register 8, DILC Output Pin Mapping	2-9
2.1.1.2.10 Register 9, DILC Input Pin Mapping	2-10
2.1.1.2.11 Register 10, Imager Internal I/O Direction Register 0	2-10
2.1.1.2.12 Register 11, Internal I/O Mux Register 0	2-11
2.1.1.2.13 Register 12, Internal I/O Mux Register 1	2-11
2.1.1.2.14 Register 13, Imager Internal I/O Direction Register 1	2-12
2.1.1.2.15 Register 14, Imager Internal I/O Mux Register 2	2-12
2.1.1.2.16 Register 15, Imager Internal I/O Mux Register 3	2-13
2.1.1.2.17 Register 16, Imager Internal I/O Direction Register 2	2-13
2.1.1.2.18 Register 17, Imager Internal I/O Mux Register 4	2-14
2.1.1.2.19 Register 18, Imager Internal I/O Mux Register 5	2-14
2.1.1.2.20 Imager Multiplexer Mapping	2-15
2.1.1.2.21 Register 19, Board RESET/EXTCLK Select Register	2-17
2.1.1.2.22 Register 20, Interrupt Select Register	2-18
2.1.1.2.23 Register 720, CCD Internal I/O Direction Register 1	2-18
2.1.1.2.24 Register 721, CCS Internal I/O Read/Write Register 1	2-19
2.1.1.2.25 Register 722, CCD Internal I/O Direction Register 2	2-19
2.1.1.2.26 Register 723, CCD Internal I/O Read/Write Register 2	2-20
2.1.1.2.27 Register 724, CCD Internal I/O Direction Register 3	2-20
2.1.1.2.28 Register 725, CCD Internal I/O Read/Write Register 3	2-21

Topic	Page
2.1.1.3 Key Pad Interface	2-21
2.1.2 DDR2 Memory Interface	2-22
2.1.3 Media Card Interface	2-22
2.1.4 UART Interface	2-22
2.1.5 USB Interface	2-22
2.2 Input Video Port/Imager Input Port Interfaces	2-23
2.2.1 On Chip Video Output DAC	2-23
2.2.2 LCD Video Connectors	2-23
2.3 AIC3101 Interface	2-24
2.4 On Chip Voice Codec	2-25
2.5 On Chip ADC	2-25
2.6 On Chip RTC	2-25
2.7 Ethernet Interface	2-26
2.8 I²C Interface	2-26
2.8.1 MSP430	2-27
2.9 Daughter Card Interface	2-27
2.10 DM368 CPU/Video Clocks	2-27
2.11 Battery	2-28

2.1 Asynchronous EMIF Interface

An asynchronous 16 bit EMIF with two chip enables divide up the address space and allow for asynchronous accesses on the EVM. This interface connects to the NAND, One NAND, and CPLD registers on the EVM board.

2.1.1 NAND Flash

The DM368 has 2 gigabytes of NAND Flash memory mapped into the CE0 space. The NAND Flash memory is used primarily for boot loading and file system on the DM368 EVM. The CE0 selects the device and needs to be configured to 8 bits wide when accessing the NAND.

Switch SW5, position 1 (OFF) selects CE0 mapped to NAND. The NAND and One NAND interface share the same CE0 chip select so only 1 device can be operational at any given time.

When the NAND flash interface is selected the spare address lines can be used by the internal DM368 key pad interface. This interface is enabled by setting a control bit in the CPLD to enable the on board CBTLV switches to the keypad matrix.

2.1.1.1 One NAND

The EVM supports 128 Megabytes of One NAND. This interface is 16 bits wide and CE0 must be configured for 16 bit wide operation when using One NAND. Switch SW5, position 1 (ON) selects the One NAND device. When the One NAND is selected the on board NAND is not available. Since the One NAND uses all the asynchronous EMIF address lines the on-chip key pad controller on the DM368 cannot be used when the One NAND is selected.

2.1.1.2 CPLD Interface

The DM368 incorporates an Altera EPM2210, 256 Ball Grid Array (BGA) CPLD. The CPLD incorporates a number of internal registers, glue logic, and I/O multiplexing to allow for a very flexible development platform. The CPLD is accessed via EMIF CE1. The interface is 8 bits wide. All registers show up as 4 mirror images in the memory window due to 32 bit addressing and 8 bit data mapping, that is BA0 and BA1 are not used in the memory decoder for registers.

Address lines A7-A3, A0, BA0, and BA1 are not used in the decoder so that these lines can be used by the keypad decoder.

The base address of CE1 is 0x0400 0000. Each additional register is accessed on an increment of 0x0000 0008. The addresses are in the following format:
A13, A12, A11, A10, A9, A8, Ax, Ax, Ax, Ax, Ax, A2, A1, Ax, Ax.

The following sections describe the registers and their function. A list of the registers is shown in the table below.

Table 1: CPLD Registers

Reg #	Entire Address	Address A13-A8	Address A2-A1	Function	R/W
0	0x0400 0000	0 0 0 0 0 0	0 0	CPLD Version	R
1	0x0400 0008	0 0 0 0 0 0	0 1	Test Register	R,W
2	0x0400 0010	0 0 0 0 0 0	1 0	LED Register	R,W
3	0x0400 0018	0 0 0 0 0 0	1 1	Board Mux Control	R,W
4	0x0400 0400	0 0 0 0 0 1	0 0	Board Switch Register	R
5	0x0400 0408	0 0 0 0 0 1	0 1	Power Control Register	R,W
6	0x0400 0410	0 0 0 0 0 1	1 0	GPIO Video Register	R,W
7	0x0400 0418	0 0 0 0 0 1	1 1	Media Card Status	R
8	0x0400 0800	0 0 0 0 1 0	0 0	DILC Output Pin Mapping	R,W
9	0x0400 0808	0 0 0 0 1 0	0 1	DILC Input Pin Mapping	R
10	0x0400 0810	0 0 0 0 1 0	1 0	Imager Internal I/O Direction Register 0	R,W
11	0x0400 0818	0 0 0 0 1 0	1 1	Imager Internal I/O Mux Register 0	R,W
12	0x0400 0A00	0 0 0 0 1 1	0 0	Imager Internal I/O Mux Register 1	R,W
13	0x0400 0A08	0 0 0 0 1 1	0 1	Imager Internal I/O Direction Register 1	R,W
14	0x0400 0A10	0 0 0 0 1 1	1 0	Imager Internal I/O Mux Register 2	R,W
15	0x0400 0A18	0 0 0 0 1 1	1 1	Imager Internal I/O Mux Register 3	R,W
16	0x0400 1000	0 0 0 1 0 0	0 0	Imager Internal I/O Direction Register 2	R,W
17	0x0400 1008	0 0 0 1 0 0	0 1	Imager Internal I/O Mux Register 4	R,W
18	0x0400 1010	0 0 0 1 0 0	1 0	Imager Internal I/O Mux Register 5	R,W
19	0x0400 1018	0 0 0 1 0 0	1 1	Board RESET Register	R,W
720	0x0400 F800	1 1 1 1 1 0	0 0	CCD Internal I/O Direction Register 1	R,W
721	0x0400 F808	1 1 1 1 1 0	0 1	CCD Internal I/O Read/Write Register 1	R,W
722	0x0400 F810	1 1 1 1 1 0	1 0	CCD Internal I/O Direction Register 2	R,W
723	0x0400 F818	1 1 1 1 1 0	1 1	CCD Internal I/O Read/Write Register 2	R,W
724	0x0400 FC00	1 1 1 1 1 1	0 0	CCD Internal I/O Direction Register 3	R,W
725	0x0400 FC08	1 1 1 1 1 1	0 1	CCD Internal I/O Read/Write Register 3	R,W

2.1.1.2.1 Register 0, CPLD Version

This read only, 8 bit register, contains the 4 bit board type and the 4 bit CPLD version for version control. The default value is 0x21 for the DM368 EVM.

2.1.1.2.2 Register 1, Test Register

This read only, 8 bit register, has a default value of 0xA5 and can be read and written to test the memory interface.

2.1.1.2.3 Register 2, LED Register

This 8 bit, read/write register controls the user LEDs. A data bit of '0' in each bit location turns on an LED. Similarly a '1' turns off the LED in each bit position.

2.1.1.2.4 Register 3, Board Mux Control Register

This 8 bit, read/write control register (default = 0x00) controls keypad, AIC, SD, Ethernet, and Video In multiplexers as shown in the table below.

Table 2: Register 3, Board Mux Control Register

Bit #	Signal	State	Function
7	EMIF_KEYPAD_CTL	0	Addresses on Muxes (ONE NAND Mode)
		1	Addresses are available for keypad
6	SEL_SD1_GPIO_CTL	0	Enables SD card slot 1
		1	Signals for SD1 card slot 1 go to CPLD imager GPIO
5	SEL_AICn_GPIO_CTL	0	Enables McBSP signals to AIC3101 codec
		1	McBSP signals go to CPLD for imager GPIO
4	Advanced LCD/Touch control	0 / 1	0 = normal mode, 1 = advanced mode for Avnet LCD panel
3	SEL_ENET_GPIO_CTL	0	Enable Ethernet signals to PHY
		1	Ethernet signals go to CPLD for imager GPIO
2	DECODER_IMAGER_S2_CTL	S[2:0]	0 0 1 = Selects TVP7002 as input to DM368 video input port 0 1 0 = Selects imager as input to DM368 video input port 1 0 1 = Selects TVP5146 as input to DM368 video input port
1	DECODER_IMAGER_S1_CTL		
0	DECODER_IMAGER_S0_CTL		

2.1.1.2.5 Register 4, Board Switch Register

This 8 bit, read only register mirrors the values set on switch SW5. These signals are shown in the table below.

Table 3: Register 4, Board Switch Register

Bit #	SW5 Position	Signal
7	Reserved	N/A
6	Reserved	N/A
5	1	SEL_NAND_LOW 0 = NAND mapped to CE0, 1 = ONE NAND mapped to CE0
4	2	SEL_EXTRA1
3	3	SEL_EXTRA2
2	4	SEL_EXTRA3
1	5	CPU_VSEL1 0 = Vcore at 1.2V 1 = Vcore at 1.35 V
0	6	SEL_NTAS_MODE

2.1.1.2.6 Register 5, Power Control Register

Register 5 is a 8 bit, read/write register that controls on board voltage regulator functions. The default data value is 0b00000000. These controls are shown in the table below.

Table 4: Register 5, Power Control Register

Bit #	Signal	Function
7	LCD_OE_5V	0,1 = Sets U32 FDC6331L Pin to 0,1
6	ENABLE_LCD_3V3	0 = Disables U31 TPS74701 1 = Enables U31 TPS74701
5	Reserved	
4	EN7	0,1 = Sets U14 TPS65530 EN7 pin to 0,1
3	ENAFE	0,1 = Sets U14 TPS65530 ENAFE pin to 0,1
2	SEQ56	0,1 = Sets U14 TPS65530 SEQ56 pin to 0,1
1	EN56	0,1 = Sets U14 TPS65530 EN56 pin to 0,1
0	ENABLE_LCD_15V	0 = Disables U34 TPS61080 register 1 = Enables U34 TPS61080 register

2.1.1.2.7 Register 6, GPIO Video Register

Register 6 is a 8 bit, read/write register that controls the mapping of GPIO30/32/33, VDIN_WE, DRV_BUS. The default data value is 0b00000000. These controls are shown in the table below.

Table 5: Register 6, GPIO Video Register

Bit #	Signal	Function
7	Reserved	
6	Reserved	
5	C_FIELD	1 = DM368 Ball E13 mapped to EXP CONN CCD_FIELD
4	C_WE	1 = DM368 Ball E13 mapped to EXP CONN CCD_WEN
3	24 BIT COLOR	1 = Map GPIO30,32,33 to G1,R0,R1 on LCD EXP CONNS
2	C_WE_FLD_VBUS_DRV	1 = DM368 BALL E13 Drives U4, TPS2065
1	GIO33_VBUS_DRV	1 = GIO33 drives U4, TPS2065
0	VBUS_DRV_ALT	1 = Drives VBUS ENABLE to U4, TPS2065

ENABLE VBUS_DRV (U4, TPS2065) will = 1 when any of the following occur:

- When SW5-2 (SEL_EXTRA1_ = 1 for test
- When VBUS_DRV_ALT = 1

ENABLE VBUS_DRV (U4, TPS2065) will = DM368 GIO33 when
GIO33_VBUS_DRV = 1

ENABLE VBUS_DRV (U4, TPS2065) will = DM368 Ball E13 when
C_WE_FLD_VBUS_DRV = 1

2.1.1.2.8 Register 7, Media Card Status

Register 7 is a 8 bit, read only register that reads the “Insert” and “Write Protect” status of media cards. These functions of these bits are shown in the table below.

Table 6: Register 7, Media Card Status

Bit #	Signal	Function
7	Reserved	Reads 0
6	Reserved	Reads 0
5	SD_MMC_1 WRITE PROTECT	0 = Write Protect
4	SD_MMC_1 INSERT	0 = Insert
3	Reserved	Reads 0
2	SD_MMC0 MS INSERT	0 = Insert
1	SD_MMC_0 WRITE PROTECT	0 = Write Protect
0	SD_MMC_0 INSERT	0 = Insert

2.1.1.2.9 Register 8, DILC Output Pin Mapping

Register 8 is a 8 bit, read/write register that maps DM368 GPIO and SPI2 pins to the DILC connector. The default data value is 0b11111111. The mapping of these pins is shown in the table below.

Table 7: Register 8, DILC Output Pin Mapping

Bit #	Signal	Function
7	DILC_DRV_VBUS	Register drives DILC DRV_VBUS pin when bit 6 = 0
6	DILC_DRV_VBUS_IO	0 = Internal register bit 7 drives DILC pin
5	DILC_VBUS_DET_DRV	Register drives DILC pin VBUS_DET when bit 4 = 0
4	DILC_VBUS_DET_IO	0 = Internal register bit 5 drives DILC pin
3	Reserved	N/A
2	CPU_GPIO32_IO	0 = IN, SPI2_DILC drives GIO32 1 = OUT, GIO32 drives SPI2_DILC
1	CPU_GPIO31_IO	0 = IN, SPI2_DILC drives GIO31 1 = OUT, GIO31 drives SPI2_DILC
0	CPU_GPIO30_IO	0 = IN, SPI2_DILC drives GIO30 1 = OUT, GIO30 drives SPI2_DILC

2.1.1.2.10 Register 9, DILC Input Pin Mapping

Register 9 is a 8 bit, read only register that maps DILC pins to read contents on this register. The mapping of these pins is shown in the table below.

Table 8: Register 9, DILC Input Pin Mapping

Bit #	Function
7	Reserved
6	Reads value of DILC connector pin GIO_DILC_DRV_VBUS1
5	Reads value of DILC connector pin GIO_DILC_DRV_DET
4	Reserved
3	Reads value of DILC connector pin GIO_DILC_DOCK_DET
2	Reads value of DILC connector pin GIO_DILC_CAM_PWR_DECT
1	Reads value of DILC connector pin GIO_DILC_AVJ_DET
0	Reads value of DILC connector pin GIO_DILC_CHG_CTL

2.1.1.2.11 Register 10, Imager Internal I/O Direction Register 0

Register 10 is a 8 bit, read/write register that controls DM368 GPIO to IMAGER connector pin input/output mapping. The default data value is 0b11111111. This mapping is shown in the table below.

Table 9: Register 10, Imager Internal I/O Direction Register 0

Bit #	Function	Mapping
7	0 = GPIO_MD8 to DM368 pin	0 = Outputs 1 = DM368 pins are inputs
6	0 = GPIO_MD7 to DM368 pin	0 = Outputs 1 = DM368 pins are inputs
5	0 = GPIO_MD6 to DM368 pin	0 = Outputs 1 = DM368 pins are inputs
4	0 = GPIO_MD5 to DM368 pin	0 = Outputs 1 = DM368 pins are inputs
3	0 = GPIO_MD4 to DM368 pin	0 = Outputs 1 = DM368 pins are inputs
2	0 = GPIO_MD3 to DM368 pin	0 = Outputs 1 = DM368 pins are inputs
1	0 = SPI4_SDI_GPIO_MD2 to DM368 pin	0 = Outputs 1 = DM368 pins are inputs
0	0 = GPIO_MD1 to DM368 pin	0 = Outputs 1 = DM368 pins are inputs

2.1.1.2.12 Register 11, Internal I/O Mux Register 0

Register 11 is a 8 bit, read/write register that controls DM368 GPIO Muxing to IMAGER connector pin input. The default data is 0b00000000. The table below shows this muxing.

Table 10: Register 11, Internal I/O Mux Register 0

Bit #	Muxing
7	0 = GPIO_MD4 MUX SELB
6	0 = GPIO_MD4 MUX SELA
5	0 = GPIO_MD3 MUX SELB
4	0 = GPIO_MD3 MUX SELA
3	0 = SPI4_SDI_GPIO_MD2 MUX SELB
2	0 = SPI4_SDI_GPIO_MD2 MUX SELA
1	0 = GPIO_MD1 MUX SELB
0	0 = GPIO_MD1 MUX SELA

2.1.1.2.13 Register 12, Internal I/O Mux Register 1

Register 12 is a 8 bit, read/write register that controls DM368 GPIO Muxing to IMAGER connector pin input. The default data is 0b00000000. The table below shows this muxing.

Table 11: Register 12, Internal I/O Mux Register 1

Bit #	Muxing
7	0 = GPIO_MD8 MUX SELB
6	0 = GPIO_MD8 MUX SELA
5	0 = GPIO_MD7 MUX SELB
4	0 = GPIO_MD7 MUX SELA
3	0 = GPIO_MD6 MUX SELB
2	0 = GPIO_MD6 MUX SELA
1	0 = GPIO_MD5 MUX SELB
0	0 = GPIO_MD5 MUX SELA

2.1.1.2.14 Register 13, Imager Internal I/O Direction Register 1

Register 13 is a 8 bit, read/write register that controls DM368 GPIO to IMAGER connector pin input/output mapping. The default data is 0b00000000. This mapping is shown in the table below.

Table 12: Register 13, Imager Internal I/O Direction Register 1

Bit #	Function	Mapping
7	0 = GPIO_MD16 to DM368 pin	0 = Outputs 1 = DM368 pins are inputs
6	0 = GPIO_MD15 to DM368 pin	0 = Outputs 1 = DM368 pins are inputs
5	0 = GPIO_MD14 to DM368 pin	0 = Outputs 1 = DM368 pins are inputs
4	0 = GPIO_MD13 to DM368 pin	0 = Outputs 1 = DM368 pins are inputs
3	0 = GPIO_MD12 to DM368 pin	0 = Outputs 1 = DM368 pins are inputs
2	0 = GPIO_MD11 to DM368 pin	0 = Outputs 1 = DM368 pins are inputs
1	0 = GPIO_MD10 to DM368 pin	0 = Outputs 1 = DM368 pins are inputs
0	0 = GPIO_MD9 to DM368 pin	0 = Outputs 1 = DM368 pins are inputs

2.1.1.2.15 Register 14, Imager Internal I/O Mux Register 2

Register 14 is a 8 bit, read/write register that controls DM368 GPIO Muxing to IMAGER connector pin input. The default data is 0b00000000. The table below shows this muxing.

Table 13: Register 12, Imager Internal I/O Mux Register 2

Bit #	Muxing
7	0 = GPIO_MD12 MUX SELB
6	0 = GPIO_MD12 MUX SELA
5	0 = GPIO_MD11 MUX SELB
4	0 = GPIO_MD11 MUX SELA
3	0 = GPIO_MD10 MUX SELB
2	0 = GPIO_MD10 MUX SELA
1	0 = GPIO_MD9 MUX SELB
0	0 = GPIO_MD9 MUX SELA

2.1.1.2.16 Register 15, Imager Internal I/O Mux Register 3

Register 14 is a 8 bit, read/write register that controls DM368 GPIO Muxing to IMAGER connector pin input. The default data is 0b00000000. The table below shows this muxing.

Table 14: Register 15, Imager Internal I/O Mux Register 3

Bit #	Muxing
7	0 = GPIO_MD16 MUX SELB
6	0 = GPIO_MD16 MUX SELA
5	0 = GPIO_MD15 MUX SELB
4	0 = GPIO_MD15 MUX SELA
3	0 = GPIO_MD14 MUX SELB
2	0 = GPIO_MD14 MUX SELA
1	0 = GPIO_MD13 MUX SELB
0	0 = GPIO_MD13 MUX SELA

2.1.1.2.17 Register 16, Imager Internal I/O Direction Register 3

Register 16 is a 8 bit, read/write register that controls DM368 GPIO to IMAGER connector pin input/output mapping. The default data is 0b00000000. This mapping is shown in the table below.

Table 15: Register 16, Imager Internal I/O Direction Register 3

Bit #	Function	Mapping
7	Reserved	
6	0 = CCD_DDS_RST to DM368 pin	0 = Outputs 1 = DM368 pins are inputs
5	0 = PWM_CCD_SUB to DM368 pin	0 = Outputs 1 = DM368 pins are inputs
4	0 = GPIO_TACH to DM368 pin	0 = Outputs 1 = DM368 pins are inputs
3	0 = GPIO_MST_SLV to DM368 pin	0 = Outputs 1 = DM368 pins are inputs
2	0 = GPIO_MD19 to DM368 pin	0 = Outputs 1 = DM368 pins are inputs
1	0 = GPIO_MD18 to DM368 pin	0 = Outputs 1 = DM368 pins are inputs
0	0 = GPIO_MD17 to DM368 pin	0 = Outputs 1 = DM368 pins are inputs

2.1.1.2.18 Register 17, Imager Internal I/O Mux Register 4

Register 17 is a 8 bit, read/write register that controls DM368 GPIO Muxing to IMAGER connector pin input. The default data is 0b00000000. The table below shows this muxing.

Table 16: Register 17, Imager Internal I/O Mux Register 4

Bit #	Muxing
7	0 = GPIO__MST_SLV MUX SELB
6	0 = GPIO__MST_SLV MUX SELA
5	0 = GPIO_MD19 MUX SELB
4	0 = GPIO_MD19 MUX SELA
3	0 = GPIO_MD18 MUX SELB
2	0 = GPIO_MD18 MUX SELA
1	0 = GPIO_MD17 MUX SELB
0	0 = GPIO_MD17 MUX SELA

2.1.1.2.19 Register 18, Imager Internal I/O Mux Register 5

Register 18 is a 8 bit, read/write register that controls DM368 GPIO Muxing to IMAGER connector pin input. The default data is 0b00000000. The table below shows this muxing.

Table 17: Register 17, Imager Internal I/O Mux Register 5

Bit #	Muxing
7	Reserved
6	Reserved
5	0 = CCD_DDS_RST MUX SELB
4	0 = CCD_DDS_RST MUX SELA
3	0 = PWM_CCD_SUB MUX SELB
2	0 = PWM_CCD_SUB MUX SELA
1	0 = GPIO_TACH MUX SELB
0	0 = GPIO_TACH MUX SELA

2.1.1.2.20 Imager Multiplexer Mapping

The CPLD GPIO functions are incorporated via CPLD control registers mapping selected CPLD/imager pins to DM368 GPIO. Each CPLD mapping function consists of 1 bit Direction control and 2 bits of multiplexer control. Most multiplexing has only 1 or 2 options, but the 2 bits in the multiplexing control were used to allow expansion of options for later revisions.

Note that many of the I/O bits are shared with other On board functions and are selected in interface groups via the CBT control bits in CPLD Register 3.

Imager IO Dir Control selects direction for CPLD pin mapping to imager connection mapping. The definition of Input is Input to CPLD therefore output from connector, the definition of output is output from CPLD therefore input to the connector. All DM368 I/O bits that are mapped by the multiplexer must be mapped to match the Imager IO Direction Control. That is if the CPLD is selected as an input the corresponding mapping pin selected on the DM368 should be selected as an input.

Table 18: Imager Multiplexer Mapping

Pin #	CPLD Imager IO Dir Bit	Imager Name	Imager-Mux Bit	Mux Selection (0)(1)	Requires CBT selection override (CPLD Reg and bit)	Mux Selection (0)(1)	Requires CBT selection override (CPLD Reg and bit)
	None (OUTPUT)	SPI4_CLK	None	SPI4_CLK			
	None (OUTPUT)	SPI4_SDO	None	SPI4_SDO			
B16	cpld_reg16(6)	CCD-RST	cpld-reg18(5)(4)	GIO3	Yes, cpld_reg3(3)	GIO40	Yes, cpld_reg3(6)
B15	cpld_reg16(5)	CCD-SUB	cpld-reg18(3)(2)	GIO92	Yes, cpld_reg3(2)(1)(0)	GIO92	Yes, cpld_reg3(2)(1)(0)
C14	cpld_reg16(4)	GPIO-TACH	cpld-reg18(1)(0)	GIO1	Yes, cpld_reg3(3)	GIO38	Yes, cpld_reg3(6)
C8	cpld_reg16(3)	MST-SLV	cpld-reg17(7)(6)	GIO35	No	GIO35	No
C6	cpld_reg16(2)	GPIO-MD19	cpld-reg17(5)(4)	GIO37	No	GIO37	No
C7	cpld_reg16(1)	GPIO-MD18	cpld-reg17(3)(2)	GIO31	No	GIO31	No
C9	cpld_reg16(0)	GPIO-MD17	cpld-reg17(1)(0)	GIO87	Yes, cpld_reg3(2)(1)(0)	GIO87	Yes, cpld_reg3(2)(1)(0)
C10	cpld_reg13(7)	GPIO-MD16	cpld-reg15(7)(6)	GIO44	Yes, cpld_reg3(5)	GIO44	Yes, cpld_reg3(5)
C11	cpld_reg13(6)	GPIO-MD15	cpld-reg15(5)(4)	GIO45	Yes, cpld_reg3(5)	GIO45	Yes, cpld_reg3(5)
C12	cpld_reg13(5)	GPIO-MD14	cpld-reg15(3)(2)	GIO46	Yes, cpld_reg3(5)	GIO46	Yes, cpld_reg3(5)
C13	cpld_reg13(4)	GPIO-MD13	cpld-reg15(1)(0)	GIO47	Yes, cpld_reg3(5)	GIO47	Yes, cpld_reg3(5)
C15	cpld_reg13(3)	GPIO-MD12	cpld-reg14(7)(6)	GIO88	Yes, cpld_reg3(2)(1)(0)	GIO88	Yes, cpld_reg3(2)(1)(0)
C16	cpld_reg13(2)	GPIO-MD11	cpld-reg14(5)(4)	GIO89	Yes, cpld_reg3(2)(1)(0)	GIO89	Yes, cpld_reg3(2)(1)(0)
B1	cpld_reg13(1)	GPIO-MD10	cpld-reg14(3)(2)	GIO86	Yes, cpld_reg3(2)(1)(0)	GIO86	Yes, cpld_reg3(2)(1)(0)
B2	cpld_reg13(0)	GPIO-MD9	cpld-reg14(1)(0)	GIO85	Yes, cpld_reg3(2)(1)(0)	GIO85	Yes, cpld_reg3(2)(1)(0)
B3	cpld_reg10(7)	GPIO-MD8	cpld-reg12(7)(6)	GIO48	Yes, cpld_reg3(5)	GIO48	Yes, cpld_reg3(5)
B4	cpld_reg10(6)	GPIO-MD7	cpld-reg12(5)(4)	GIO91	Yes, cpld_reg3(2)(1)(0)	GIO91	Yes, cpld_reg3(2)(1)(0)
B11	cpld_reg10(5)	GPIO-MD6	cpld-reg12(3)(2)	GIO90	Yes, cpld_reg3(2)(1)(0)	GIO90	Yes, cpld_reg3(2)(1)(0)
B12	cpld_reg10(4)	GPIO-MD5	cpld-reg12(1)(0)	GIO49	Yes, cpld_reg3(5)	GIO49	Yes, cpld_reg3(5)
B13	cpld_reg10(3)	GPIO-MD4	cpld-reg11(7)(6)	GIO2	Yes, cpld_reg3(3)	GIO39	Yes, cpld_reg3(6)
B17	cpld_reg10(2)	GPIO-MD3	cpld-reg11(5)(4)	GIO4	Yes, cpld_reg3(3)	GIO41	Yes, cpld_reg3(6)
B18	cpld_reg10(1)	SPI4_SDI_ GPIO_MD2	cpld-reg11(3)(2)	GIO5	Yes, cpld_reg3(3)	GIO42	Yes, cpld_reg3(6)
A4	cpld_reg10(0)	GPIO-MD1	cpld-reg11(1)(0)	GIO6	Yes, cpld_reg3(3)	GIO43	Yes, cpld_reg3(6)

2.1.1.2.21 Register 19, Board RESET/EXTCLK Select Register

Register 19 is a 8 bit, read/write register that allows the user to select reset to major external peripherals, and select an external clock for the DM368 EXT PIN (B19). The default data is 0b10000000. The table below shows the mapping of these bits. The external clock on the DM368 CPLD is 74.25 MHz. This clock can be divided and input into the DM368 EXTCLK pin (B19).

Table 19: Register 19, Board RESET/EXTCLK Select Register

Bit #	Signal	State Action
7	EXTCLK_ENABLE	1 = Enable CPLD to drive EXTCLK 0 = Disable EXTCLK, tristate PLD drive of EXTCLK
6	EXT_CLK_SEL1	00 = select 9.28 MHz 01 = select 18.56 MHz 10 = select 37.125 MHz 11 = select 74.25 MHz
5	EXT_CLK_SEL0	
4	CCD_RESET	1 = CCD_DDS_RST 0 = CCD_DDS_RST driven low when mux output is selected
3	ETHERNET_RESET	1 = Force Reset to Logic 0 0 = Map Reset to CPLD RESET inputs
2	TVP7002_RESET	1 = Force Reset to Logic 0 0 = Map Reset to CPLD RESET inputs
1	AIC3106_RESET	1 = Force Reset to Logic 0 0 = Map Reset to CPLD RESET inputs
0	TVP5146_RESET	1 = Force Reset to Logic 0 0 = Map Reset to CPLD RESET inputs

2.1.1.2.22 Register 20, Interrupt Select Register

Register 20 is a 8 bit, read/write register that controls the interrupt source to GPIO0 of the DM368 processor. The default data is 0b00000000. The table below shows the mapping of these bits.

Table 20: Register 20, Interrupt Select Register

Bit #	State Action
7	Reserved
6	Reserved
5	Reserved
4	Reserved
3	Reserved
2	Reserved
1	1 = selects CPLD_CONN_GPIO7
0	1 = selects MSP430_int

When 00 is selected on bits 0,1 CPLD Register 3 (4) selects source of interrupt.

2.1.1.2.23 Register 720, CCD Internal I/O Direction Register 1

Register 720 is a 8 bit, read/write register that controls CPLD GPIO to CCD Connector pin input/output mapping. The default data is 0b11111111. The table below shows the mapping of these bits.

Table 21: Register 720, CCD Internal I/O Direction Register 1

Bit #	Signal	State Action
7	0 = GPIO_0.7DIR	0 = Outputs, 1 = Inputs
6	0 = GPIO_0.6DIR	0 = Outputs, 1 = Inputs
5	0 = GPIO_0.5DIR	0 = Outputs, 1 = Inputs
4	0 = GPIO_0.4DIR	0 = Outputs, 1 = Inputs
3	0 = GPIO_0.3DIR	0 = Outputs, 1 = Inputs
2	0 = GPIO_0.2DIR	0 = Outputs, 1 = Inputs
1	0 = GPIO_0.1DIR	0 = Outputs, 1 = Inputs
0	0 = GPIO_0.0DIR	0 = Outputs, 1 = Inputs

2.1.1.2.24 Register 721, CCD Internal I/O Read/Write Register 1

Register 721 is a 8 bit, read/write register that controls CPLD GPIO input on read, and out value on write. The default data is 0b00000000. The table below shows the mapping of these bits.

Table 22: Register 721, CCD Internal I/O Read/Write Register 1

Bit #	Signal	State Action
7	0 = GPIO_0.7	Write bit when DIR = 0 Read bit when DIR = 1
6	0 = GPIO_0.6	Write bit when DIR = 0 Read bit when DIR = 1
5	0 = GPIO_0.5	Write bit when DIR = 0 Read bit when DIR = 1
4	0 = GPIO_0.4	Write bit when DIR = 0 Read bit when DIR = 1
3	0 = GPIO_0.3	Write bit when DIR = 0 Read bit when DIR = 1
2	0 = GPIO_0.2	Write bit when DIR = 0 Read bit when DIR = 1
1	0 = GPIO_0.1	Write bit when DIR = 0 Read bit when DIR = 1
0	0 = GPIO_0.0	Write bit when DIR = 0 Read bit when DIR = 1

2.1.1.2.25 Register 722, CCD Internal I/O Direction Register 2

Register 722 is a 8 bit, read/write register that controls CPLD GPIO to CCD Connector pin input/output mapping. The default data is 0b11111111. The table below shows the mapping of these bits.

Table 23: Register 722, CCD Internal I/O Direction Register 2

Bit #	Signal	State Action
7	0 = GPIO_1.7DIR	0 = Outputs, 1 = Inputs
6	0 = GPIO_1.6DIR	0 = Outputs, 1 = Inputs
5	0 = GPIO_1.5DIR	0 = Outputs, 1 = Inputs
4	0 = GPIO_1.4DIR	0 = Outputs, 1 = Inputs
3	0 = GPIO_1.3DIR	0 = Outputs, 1 = Inputs
2	0 = GPIO_1.2DIR	0 = Outputs, 1 = Inputs
1	0 = GPIO_1.1DIR	0 = Outputs, 1 = Inputs
0	0 = GPIO_1.0DIR	0 = Outputs, 1 = Inputs

2.1.1.2.26 Register 723, CCD Internal I/O Read/Write Register 2

Register 723 is a 8 bit, read/write register that controls CPLD GPIO input on read, and out value on write. The default data is 0b00000000. The table below shows the mapping of these bits.

Table 24: Register 723, CCD Internal I/O Read/Write Register 2

Bit #	Signal	State Action
7	0 = GPIO_0.7	Write bit when DIR = 0 Read bit when DIR = 1
6	0 = GPIO_0.6	Write bit when DIR = 0 Read bit when DIR = 1
5	0 = GPIO_0.5	Write bit when DIR = 0 Read bit when DIR = 1
4	0 = GPIO_0.4	Write bit when DIR = 0 Read bit when DIR = 1
3	0 = GPIO_0.3	Write bit when DIR = 0 Read bit when DIR = 1
2	0 = GPIO_0.2	Write bit when DIR = 0 Read bit when DIR = 1
1	0 = GPIO_0.1	Write bit when DIR = 0 Read bit when DIR = 1
0	0 = GPIO_0.0	Write bit when DIR = 0 Read bit when DIR = 1

2.1.1.2.27 Register 724, CCD Internal I/O Direction Register 3

Register 724 is a 8 bit, read/write register that controls CPLD GPIO to CCD Connector pin input/output mapping. The default data is 0b11111111. The table below shows the mapping of these bits.

Table 25: Register 724, CCD Internal I/O Direction Register 3

Bit #	Signal	State Action
7	0 = GPIO_2.7DIR	0 = Outputs, 1 = Inputs
6	0 = GPIO_2.6DIR	0 = Outputs, 1 = Inputs
5	0 = GPIO_2.5DIR	0 = Outputs, 1 = Inputs
4	0 = GPIO_2.4DIR	0 = Outputs, 1 = Inputs
3	0 = GPIO_2.3DIR	0 = Outputs, 1 = Inputs
2	0 = GPIO_2.2DIR	0 = Outputs, 1 = Inputs
1	0 = GPIO_2.1DIR	0 = Outputs, 1 = Inputs
0	0 = GPIO_2.0DIR	0 = Outputs, 1 = Inputs

2.1.1.2.28 Register 725, CCD Internal I/O Read/Write Register 3

Register 725 is a 8 bit, read/write register that controls CPLD GPIO input on read, and out value on write. The default data is 0b00000000. The table below shows the mapping of these bits.

Table 26: Register 725, CCD Internal I/O Read/Write Register 1

Bit #	Signal	State Action
7	0 = GPIO_0.7	Write bit when DIR = 0 Read bit when DIR = 1
6	0 = GPIO_0.6	Write bit when DIR = 0 Read bit when DIR = 1
5	0 = GPIO_0.5	Write bit when DIR = 0 Read bit when DIR = 1
4	0 = GPIO_0.4	Write bit when DIR = 0 Read bit when DIR = 1
3	0 = GPIO_0.3	Write bit when DIR = 0 Read bit when DIR = 1
2	0 = GPIO_0.2	Write bit when DIR = 0 Read bit when DIR = 1
1	0 = GPIO_0.1	Write bit when DIR = 0 Read bit when DIR = 1
0	0 = GPIO_0.0	Write bit when DIR = 0 Read bit when DIR = 1

2.1.1.3 Key Pad Interface

The DM368 has an internal key pad controller. The key pad interface is multiplexed with the address lines on the asynchronous EMIF. CBTLV multiplexers are used to redirect the key pad interface to the key pad matrix. This interface can only be used when CE0 is in the NAND configuration. A control bit in the CPLD enables the Mux select on the CBTLV multiplexers. The 16 bit switch key pad matrix is set up on a 4 x 4 matrix on the EVM. The mapping of the switches are shown in the table below.

Table 27: Key Pad Layout

	Key-A0	Key-A0	Key-A1	Key-A1
Key-B0	SW6 / KEY 2	SW7 / LEFT	SW8 / EXIT	SW9 / DOWN
Key-B0	SW10 / ENTER	SW11 / UP	SW12 KEY 1	SW13 / RIGHT
Key-B1	SW14 / MENU	SW15 / REC	SW16 / REW	SW17 / SKIP-
Key-B1	SW18 / STOP	SW19 / FF	SW20 / SKIP+	SW2 / PLAY/ PAUSE

2.1.2 DDR2 Memory Interface

The DM368 device incorporates a dedicated 16 bit wide DDR2 memory bus. The EVM uses a single 1 gigabit 16 bit wide memory on this bus, for a total of 128 megabytes of memory for program, data, and video storage. The internal DDR controller uses a PLL to control the DDR memory timing. Memory refresh for DDR2 is handled automatically by the DM368 internal DDR controller.

2.1.3 Media Card Interface

The EVM supports 1 SD/MMC/MS and 1 SD/MMC media card interfaces. The MMC/SD0 port is dedicated to the SD/MMC/MS media card. The insert and write protect status can be read via CPLD register. MMC/SD1 port is configured to a second SD/MMC media card. This port is multiplexed via CBTLV switches to be used as general purpose I/O pins when the CPLD is appropriately configured for I/O multiplexing. The insert and write protect pin status can be read via a CPLD register.

2.1.4 UART Interface

The internal UART0 on the DM368 device is driven to connector P1. The UART's interface is routed to the RS-232 line drivers prior to being brought out to a DB-9 connector, P1.

2.1.5 USB Interface

The DM368 incorporates an on chip USB II controller. This interface is brought out to a mini A/B connector. Two jumpers are provided to make a flexible Host peripheral, and USB On The Go interface. J26 is used to manually select the ID pin state. J6 is used to add additional capacitance to VBUS for host mode operation. A TPS2065 is used to power VBUS via DRV_VBUS signal for Host mode applications. The CPLD selects the source pin for DRV_VBUS signals via internal CPLD registers.

2.2 Input Video Port Interfaces/Imager Input Ports

The DM368 EVM supports composite, component, or imager video capture. CBT multiplexers selected via CPLD registers chose the interface that is connected to the DM368 video input port. A Texas Instruments TVP5146 is used to decode composite video or S-video inputs into the device. J15 is used for the S-video inputs and J13 for the composite inputs on the EVM.

A TVP7002 provides component image capture up to 720P resolution.

J11, J8, J9 interface to a THS7353 amplifier/filter which interfaces directly to the TVP7002 which drives the DM368 input port.

J10, a DIN96 connector allows users to support imager interfaces. This is mapped directly to the video input port via CBT mux. The figure below shows this mapping,

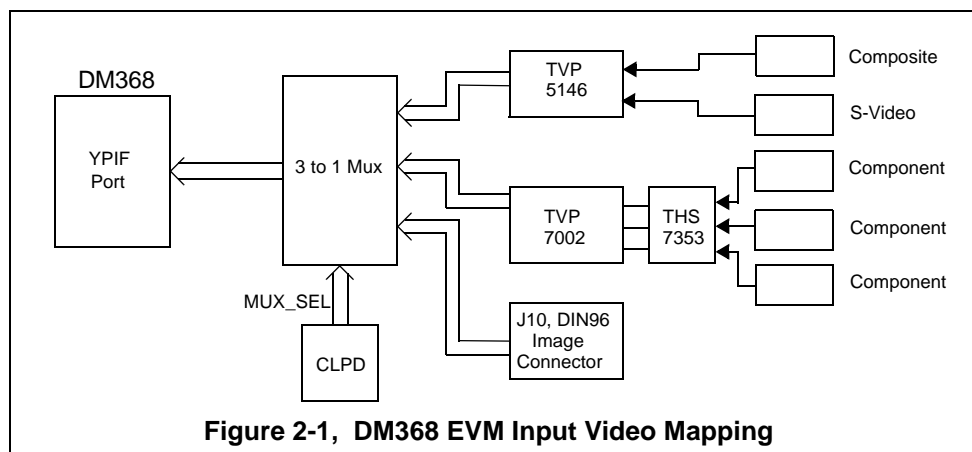

2.2.1 On Chip Video Output DAC

The DM368 incorporates 1 TV composite video output DAC and 3 component video DACs to interface to composite and component video outputs. The TV Out DAC is filtered and driven to RCA jack, J16.

The component output DACs are driven into a THS7303 video amplifier and output to RCA connectors J21, J17, J20.

2.2.2 LCD Video Connectors

The DM368 incorporates 3 interface connectors; J18, J19, and J23 for digital video output for interfacing to LCD displays. The pinouts for these displays are detailed in section 3 of this manual.

2.3 AIC3101 Interface

The EVM uses a Texas Instruments TLV320AIC3101 stereo codec for input and output of audio signals. The codec samples analog signals on the microphone or line inputs and converts them into digital data so it can be processed by the DSP. When the DSP is finished with the data it uses the codec to convert the samples back into analog signals on the line output so the user can hear the output.

The codec communicates using two serial channels, one to control the codec's internal configuration registers and one to send and receive digital audio samples. The I²C bus is used as the AIC3101's control channel. The control channel is generally only used when configuring the codec, it is typically idle when audio data is being transmitted,

The DM368's McBSP is used as the bi-directional data channel. All audio data flows through the data channel. Many data formats are supported based on the three variables of sample width, clock signal source and serial data format. The EVM examples generally use a 16-bit sample width with the codec in master mode so it generates the frame sync and bit clocks at the correct sample rate without effort on the DSP side.

The codec is clocked via a 27 Mhz oscillator. The internal sample rate generator subdivides the default system clock to generate common audio frequencies. The sample rate is set by a codec register. The figure below shows the codec interface on the DM368 EVM.

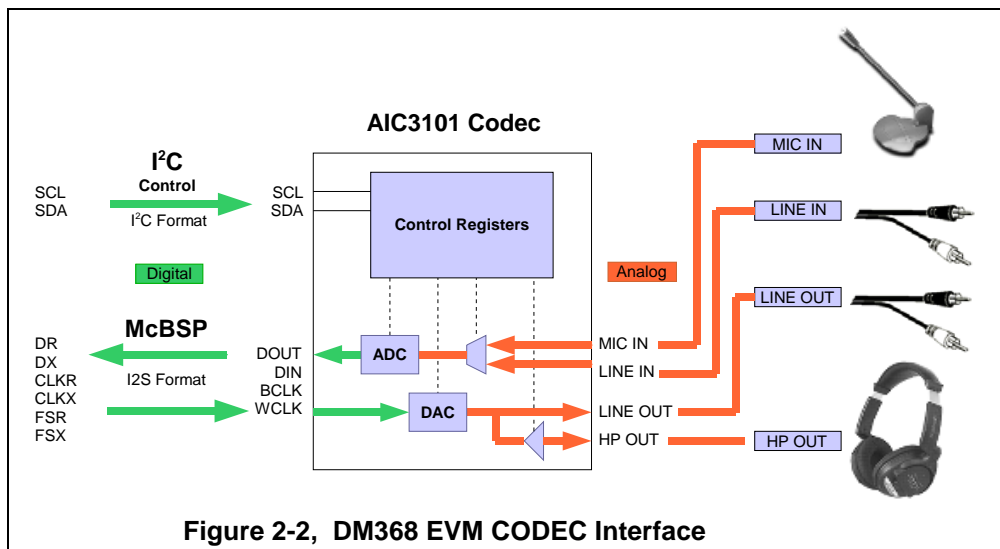

2.4 On Chip Voice Codec

The DM368 integrates a single channel voice codec. The input for this codec is connected to on board microphone M1. The output of this codec is connected to on board speaker SPK1.

2.5 On Chip Analog to Digital Converter (ADC)

The DM368 has an on chip 6 channel Analog to Digital Converter (ADC). Four of the channels are interfaced to on board voltages and two channels are connected to test points as shown in the table below.

Table 28: On Chip Analog to Digital Converter

Channel	Input Signal
ADC_CH0	CCD_PSMON
ADC_CH1	VCC_3V3
ADC_CH2	CPU_VCC_1V8
ADC_CH3	VCC_1V2
ADC_CH4	TP37
ADC_CH5	TP36

2.6 On Chip RTC

The DM368 integrates an on chip real time clock. The Real Time Clock is battery backed up via TPS65510 and Battery BHT1. The EVM is not shipped with a backup battery. The mode of operation for the Real Time Clock is configured via switch SW23, as defined in section 3.

2.7 Ethernet Interface

The DM368 incorporates an internal MII ethernet MAC which interfaces to a Mircel 10/100 ethernet Phy. The 10/100 Mbit interface is isolated and brought out to a RJ-45 standard ethernet connector, P2. The ethernet address is stored in the on board I²C EEPROM manufacturing.

For GPIO modes of operation when the MII interface is not used CBTLV multiplexes and directs the I/O to the on board CPLD used as imager expansion I/Os.

The RJ-45 has 2 LEDs integrated into its connector. The LEDs are green and yellow and indicate the status of the ethernet link. The green LED, when on, indicates link and when blinking indicates link activity. The yellow LED, when illuminated, indicates full duplex mode.

2.8 I²C Interface

The I²C bus on the DM368 is ideal for interfacing to the control registers of many devices. On the DM368 EVM the I²C bus is used to configure the video decoders, stereo Codec, video amplifiers, I2C EEPROM, and communicate with the MSP430. An I²C ROM is also interfaced via the serial bus. The format of the bus is shown in the figure below.

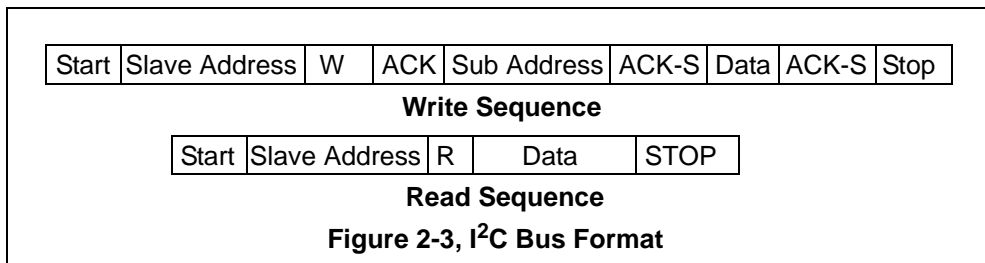

The addresses of the on board peripherals are shown in the table below.

Table 29: I²C Memory Map

Device	Address	R/W	Function
AIC3101	0x18	R/W	CODEC
MSP430	0x25	R/W	IR Controller
THS7303	0x2C	R/W	Video Output Amplifier
THS7353	0x2E	R/W	Video Input Amplifier
CAT24C256	0x50	R/W	I ² C EEROM
TVP7002	0x5C	R/W	Component Decoder
TVP5146	0x5D	R/W	Composite 1 Decoder

2.8.1 MSP430

The DM368 EVM incorporates infrared remote, interface using a MSP430 microcontroller. The I²C interface is used on the DM368 processor to communicate to the MSP430. The MSP430 acts as a slave device on the I²C bus.

2.9 Daughter Card Interfaces

The EVM provides expansion connectors that can be used to accept plug-in daughter cards. The daughter card allows users to build on their EVM platform to extend its capabilities and provide customer and application specific interfaces. The Asynchronous EMIF is brought out to J14. The video digital output port is brought out to the daughter card interface along with I/O and imager interface is brought out to a DIN96 connector as detailed previously.

2.10 DM368 CPU/Video Clocks

The DM368 EVM uses a 24 Megahertz crystal to generate the main input clock. The DM368 has multiple internal PLLs which can multiply the input clock to generate the internal clocks. The PLL's multipliers are set via software on the DM368 device.

The Real Time clock uses a 32,768 hertz crystal.

2.11 Battery

The DM368 EVM incorporates a battery holder to provide backup power to the internal real time clock when the power is not applied to the board. The optional battery should be +3 volt 20 millimeter coin type Lithium single cell.

Some common part numbers for batteries which should operate in the EVM are shown in the table below.

Table 30: Battery Part Numbers

Part Numbers
CR2032
DL2032
BR2032
CR2025
BR2025
CR2016
BR2016
DL2016

These batteries are available from Duracell, Eveready, Panasonic, Ray-O-Vac, Sanyo, Sony, Sieko, Toshiba, Varta, and other battery manufacturers.

Physical Description

This chapter describes the physical layout of the DM368 EVM and its interfaces.

Topic	Page
3.1 Board Layout	3-3
3.2 Connectors	3-5
3.2.1 J1, USB MiniAB Connector and Jumpers	3-6
3.2.2 J2, 14 Pin External JTAG Connector	3-7
3.2.3 J3, MSP430 JTAG Header	3-8
3.2.4 J4, Spare Jumper Holder	3-8
3.2.5 J5, 20 Pin ARM JTAG Emulation Header	3-9
3.2.6 J6, USB Capacitance Select	3-9
3.2.7 J7, +5 Volts Input	3-10
3.2.8 J12, SD/MMC/MS Card Interface	3-10
3.2.9 J10, Imager Interface	3-11
3.2.10 J14, EMIF/UPI DC Interface	3-12
3.2.11 J8, Y Component Video In, RCA Jack (Green)	3-13
3.2.12 J9, Pb Component Video In, RCA Jack (Blue)	3-13
3.2.13 J11, Pr Component Video In, RCA Jack (Red)	3-14
3.2.14 J15, S-Video In	3-14
3.2.15 J13, CVBS/Y Input, RCA Jack (Yellow)	3-15
3.2.16 J16, Composite TV Out, RCA Jack (Yellow)	3-15
3.2.17 J17, Y Component Video Out, RCA Jack (Green)	3-16
3.2.18 J20, Pb Component Video Out, RCA Jack (Blue)	3-16
3.2.19 J21, Pr Component Video Out, RCA Jack (Red)	3-17
3.2.20 J18, J19, Video Output DC	3-18
3.2.21 J22, CPLD Programming Header	3-19
3.2.22 J23, I/O Interface Header	3-19
3.2.23 J24, DILC Host Connector	3-20
3.2.24 J25, MMC/SD Connector	3-21
3.2.26 P1, RS-232 UART	3-22
3.2.27 P2, Ethernet Interface	3-23
3.2.28 P3, Microphone In	3-24

Topic	Page
3.2.29 P4, Line In	3-24
3.2.30 P5, Line Out	3-25
3.2.31 P6, Headphone Out	3-25
3.2.32 U1, Infrared Interface	3-26
3.2.33 SPK1, Speaker Interface	3-26
3.2.34 BHT1, Battery Interface	3-27
3.2.35 M1, Microphone Interface	3-27
3.3 LEDs	3-28
3.4 Switches	3-29
3.4.1 SW1, EMU0/1 Select Switch	3-30
3.4.2 SW2, PWCTRO0 Pushbutton	3-30
3.4.3 SW3, RESET Pushbutton	3-30
3.4.4 SW4, Boot Mode / Processor Configuration Select	3-31
3.4.5 SW5, Board Configuration Select	3-32
3.4.6 SW6 - SW21, Function Pushbuttons	3-32
3.4.7 SW22, MSP430 IO0 Pushbutton	3-33
3.4.8 SW23, PRTSC Mode Select	3-33
3.5 Jumpers	3-34
3.5.1 JP1, Jumper Block	3-34
3.5.2 JP2, Unpopulated Jumper	3-34
3.5.3 JP28, Unpopulated Jumper	3-34
3.5.4 J26, USB ID Select	3-35
3.5.5 J27, U14 LL8 Voltage Select	3-35
3.6 Test Points	3-36

3.1 Board Layout

The DM368 EVM is a 8.0 x 8.7 inch (203 x 221 mm.) ten (10) layer printed circuit board which is powered by an external +5 volt only power supply. Figure 3-1 shows the layout of the top side of the DM368 EVM.

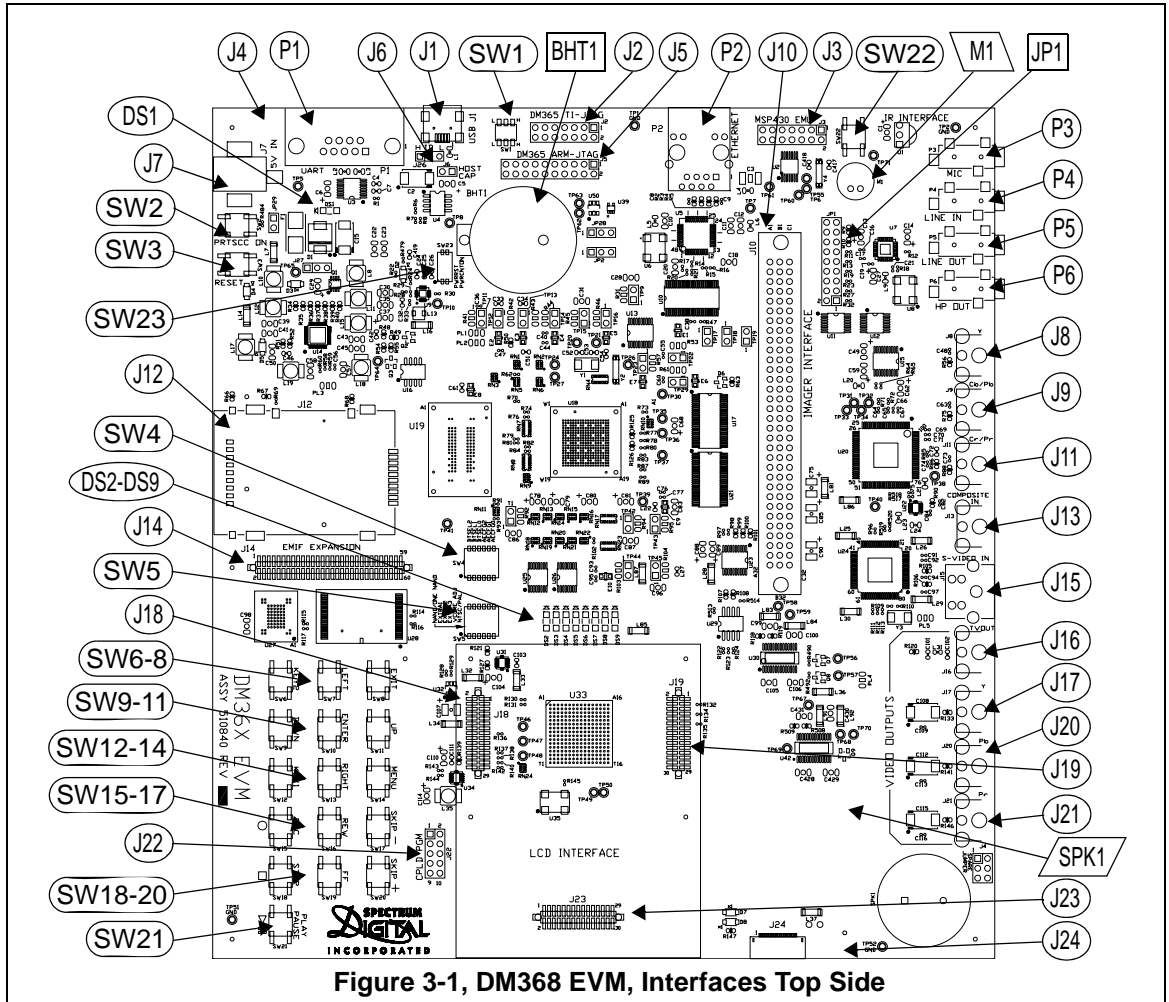

Figure 3-2 shows the layout of the bottom side of the DM368 EVM.

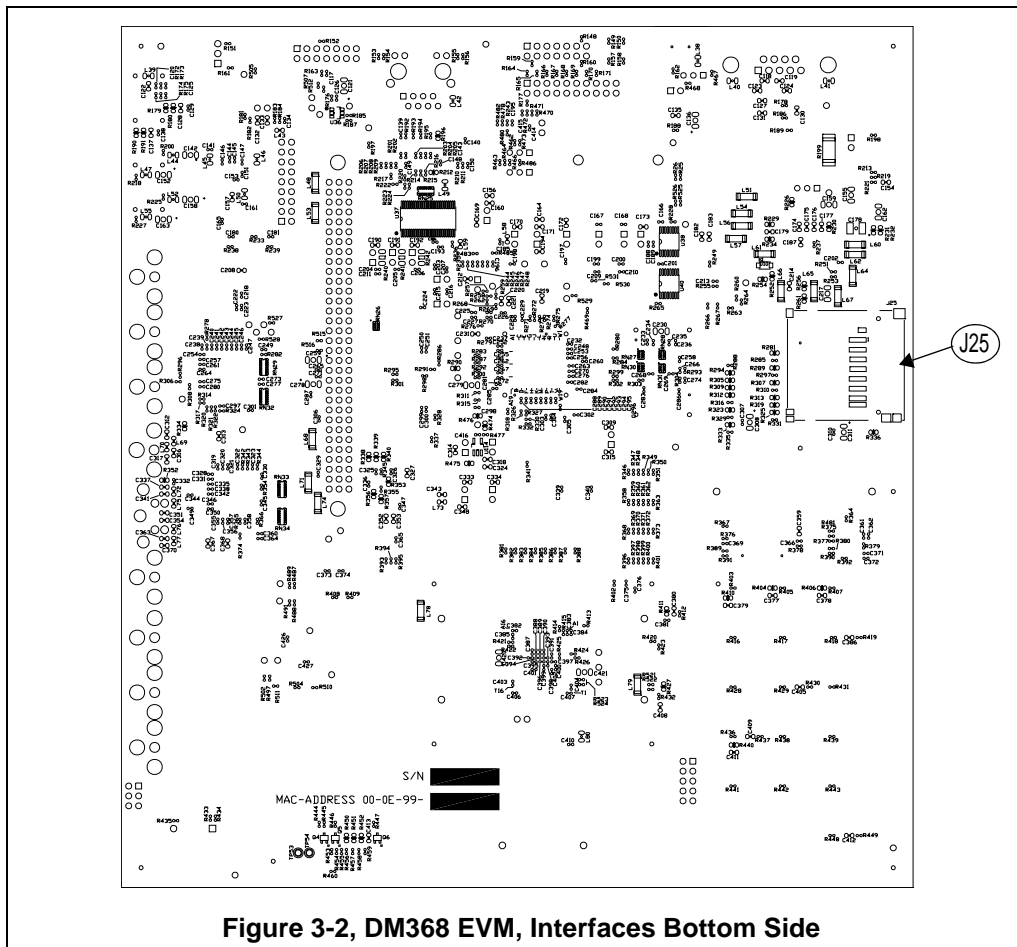

Figure 3-2, DM368 EVM, Interfaces Bottom Side

3.2 Connectors

The DM368 EVM has numerous connectors, option jumpers, and interfaces to control and provide connections to various peripherals. These connectors and jumpers are described in the following sections.

Table 1: DM368 Connectors

Connector	Size	Schematic Page	Function
J1	1 x 4	18	USB MiniAB Connector
J2	2 x 7	19	14 Pin TI JTAG Emulation Header
J3	7 x 2	44	MSP430 JTAG Header
J4	3 x 2	18	Spare Jumper Holder
J5	10 x 2	19	20 Pin ARM JTAG Emulation Header
J6	2 x 1	18	USB Capacitor Select
J7	2	52	+5 Volts In
J8	2	36	Y Component Video In, RCA Jack (Grn)
J9	2	36	Pb Component Video In, RCA Jack (Blue)
J10	32 x 3	34	Imager Interface
J11	2	36	Pr Component Video In, RCA Jack (Red)
J12	2	30	SD/MMC/MS Card Interface
J13	2	37	CVBS/Y Input, RCA Jack (Yellow)
J14	30 x 2	25	EMIF/UPHI DC Interface
J15	4	37	S-video In, DIN connector
J16	2	7	Composite TV Out, RCA Jack (Yellow)
J17	2	32	Y Component Video Output, RCA Jack (Green)
J18	15 x 2	40	Video Output DC
J19	15 x 2	40	Video Output DC
J20	2	32	Pb Component Video Output, RCA Jack (Blue)
J21	2	32	Pr Component Video Output, RCA Jack (Red)
J22	5 x 2	20	CPLD Programming Header
J23	15 x 2	40	I/O Interface Header
J24	20 x 1	41	DILC Host Connector
J25	9	31	MMC/SD Card Interface
P1	9	29	RS-232 UART
P2	6	43	Ethernet Interface
P3	4	39	Microphone In
P4	4	39	Line In
P5	4	39	Line Out
P6	4	39	Headphone Out
U1	3	44	Infrared Interface
SPK1	2	12	Speaker
BHT1	2	47	Battery Holder
M1	2	12	Microphone

3.2.1 J1, USB MiniAB Connector and Jumpers

Connector J1 is a mini A/B USB connector. The pinout for the J1 connector is shown in the table below.

Table 2: J1, MiniAB USB Connector

Pins	Signal
1	USB_VBUS_CONN
2	USB_DM
3	USB_DP
4	USB_ID
5	GND

The EVM incorporates the ability to toggle the ID pin on the USB connector via software control. The USB_ID pin on the DM368 controls this function.

For “USB ON The Go” mode remove jumper J6. This will allow the cable to configure the ID pin on the DM368 processor.

The EVM supplies up to 500 ma of current to the USB_VBUS via a TPS61092 DC/DC converter. This is enabled via the DM368’s DRV_VBUS pin. J50 supplies extra capacitance for host mode operations. Remove J50 for “USB On The Go” operations. Spare jumpers can be stored on connector J4.

3.2.2 J2, 14 Pin External JTAG Connector

Connector J2 is a 2 x 7 double row male header with pin 6 clipped to serve as a key. This is the standard interface used by JTAG emulators to interface to Texas Instruments processors. The pinout for the connector is shown in the figure below.

TMS	1	2	TRST-	
TDI	3	4	GND	Header Dimensions
PD (+3.3V)	5	6	no pin (key)	Pin-to-Pin spacing, 0.100 in. (X,Y)
TDO	7	8	GND	Pin width, 0.025-in. square post
TCK-RET	9	10	GND	Pin length, 0.235-in. nominal
TCK	11	12	GND	
EMU0	13	14	EMU1	

Figure 3-3, J2, 14 Pin External JTAG Connector

The signal names for each pin are shown in the table below.

Table 3: J2, 14 Pin External JTAG Connector

Pin #	Signal Name	Pin #	Signal Name
1	TMS	2	TRST-
3	TDI	4	GND
5	PD	6	no pin - key
7	TDO	8	GND
9	TCKRET	10	GND
11	TCK	12	GND
13	EMU0	14	EMU1

* **Note:** EMU0/EMU1 mode must be selected to ICEPICK mode

3.2.3 J3, MSP430 JTAG Header

The J3, MSP430 JTAG header, is located on the top side of the board and is used to provide a programming interface to the MSP430 microcontroller. The pinout for the J3 connector is shown in the table below. This connector is typically used for factory use only.

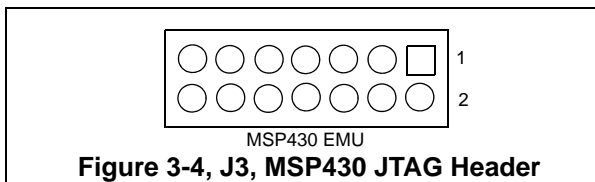

Table 4: J3, MSP430 JTAG Header

Pin #	Signal	Pin #	Signal
1	430_TDO/TDI	2	NC
3	NC	4	MSP430_3V3
5	NC	6	NC
7	TCK	8	NC
9	GND	10	NC
11	NC	12	NC
13	NC	14	NC

3.2.4 J4, Spare Jumper Holder

J4 is a 3 x 2 connector used to hold unused jumper plugs that from time to time may be required in other connectors/jumpers on the D368 EVM. The pins on this connector are not connected to any signals.

3.2.5 J5, 20 Pin ARM JTAG Emulation Header

The J5 emulation header is located on the top side of the board and is used to provide an interface to ARM compatible JTAG emulators. The pinout for this connector is shown in the table below.

Table 5: J5, 20 Pin ARM JTAG Emulation Header

Pin #	Signal	Pin #	Signal
1	VCC_3V3	2	VCC_3V3
3	ARM_TRSTn	4	Ground
5	ARM_TDI	6	Ground
7	ARM_TMS	8	Ground
9	ARM_TCK	10	Ground
11	ARM_TCKRET	12	Ground
13	ARM_TDO	14	Ground
15	ARM_RSTn	16	Ground
17	NC	18	Ground
19	NC	20	Ground

* **Note:** EMU0/EMU1 switch must be set to ARM mode

3.2.6 J6, USB Capacitance Select

The J6 jumper is used to provide more capacitance when the USB connector is used in the host mode. When the jumper is shorted the extra capacitance is provided. These open and shorted position are shown below.

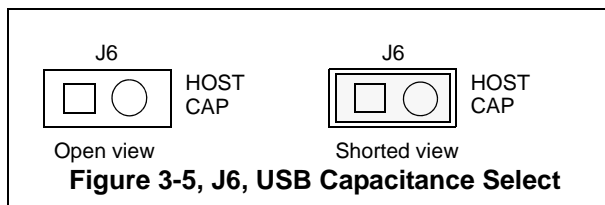
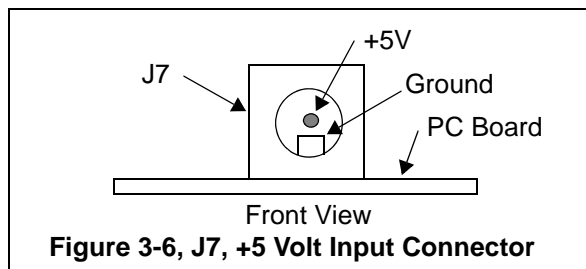

Table 6: J6, USB Capacitance Select

Position	Function
Open	6.8 uF Capacitance
Shorted	106.8 uF Capacitance

3.2.7 J7, +5 Volts Input

Connector J7 is the input power connector. This connector brings in +5 volts to the EVM. This is a 2.5mm. jack. The inside of the jack is tied to through a fuse to VCC_5V. The other side is tied to ground and LED DS1. The figure below shows this connector as viewed from the card edge.



3.2.8 J12, SD/MMC/MS Card Interface

The J12 SD/MMC/MS Card Interface connector is located on the top side of the board and is used to provide an interface to a SD/MMC/MS card. The pinout for the J12 connector is shown in the table below.

Table 7: J12, SD/MMC/MS Connector

Pin #	Signal	Pin #	Signal
1	SD.DATA3	2	SD.CMD
3	SD.VSS1	4	SD.VDD/VCC_3V3
5	SD.CLK	6	SD.VSS2
7	SD.DATA0	8	SD.DATA1
9	SD.DATA2	10	GND
11	MS.BS	12	MS.DATA1
13	MS.SDIO/DATA0	14	MS.DATA2
15	MS.XINS	16	MS.DATA3
17	MS.CLK	18	MS.VCC/VCC_3V3
19	GND	20	WP
21	INS	22	GND
23	GND		

3.2.9 J10, Imager Interface

Connector J10 is 32 x 3 connector used to interface to external imager logic. The pin out for this connector is shown in the table below.

Table 8: J10, Imager Interface

Pin	Signal	Pin	Signal	Pin	Signal
A1	Ground	B1	GPIO_MD10	C1	GND_STB
A2	Ground	B2	GPIO_MD9	C2	GND_STB
A2	CCD_PSMON	B2	GPIO_MD8	C2	3V3_STB
A4	GPIO_MD1	B4	GPIO_MD7	C4	5V_DC_J6
A5	5V_DC_J6	B5	5V_DC_J6	C5	5V_DC_J6
A6	GND_MTR	B6	MOT_PWR	C6	GPIO_MD19
A7	GND_MTR	B7	MOT_PWR	C7	GPIO_MD18
A8	NC	B8	CCD_DATA0	C8	GPIO_MST_SLV
A9	CDD_DATA2	B9	CCD_DATA15	C9	GPIO_MD17
A10	Ground	B10	CCD_DATA1	C10	GPIO_MD16
A11	CDD_DATA3	B11	GPIO_MD6	C11	GPIO_MD15
A12	Ground	B12	GPIO_MD5	C12	GPIO_MD14
A13	CDD_DATA4	B13	GPIO_MD4	C13	GPIO_MD13
A14	Ground	B14	Ground	C14	GPIO_TACH
A15	CDD_DATA5	B15	PWM_CCD_SUB	C15	GPIO_MD12
A16	Ground	B16	CCD-DDSRST	C16	GPIO_MD11
A17	CDD_DATA6	B17	GPIO_MD3	C17	I2C_DATA
A18	Ground	B18	SPI4_SDI_GPIO_MD2_CONN	C18	I2C_SCLK
A19	CDD_DATA7	B19	SPI4_SDO_CONN	C19	VCC_CCD15V
A20	Ground	B20	SPI4_SCLK_CONN	C20	VCC_CCD15V
A21	CDD_DATA8	B21	Ground	C21	VCC_CCD_N7V5
A22	Ground	B22	CDD_PCLK	C22	VCC_CCD_N7V5
A23	CDD_DATA9	B23	Ground	C23	3V3_CCD
A24	Ground	B24	CDD_WEN	C24	3V3_CCD
A25	CDD_DATA10	B25	Ground	C25	5V_DC_J6
A26	Ground	B26	CDD_FIELD	C26	5V_DC_J6
A27	CDD_DATA11	B27	Ground	C27	Ground
A28	Ground	B28	CDD_HSYNC	C28	Ground
A29	CDD_DATA12	B29	Ground	C29	3V3A_CCD
A30	Ground	B30	CDD_VSYNC	C30	3V3A_CCD
A31	CDD_DATA13	B31	Ground	C31	AGND_IMAGER
A32	Ground	B32	CDD_DATA14	C32	AGND_IMAGER

3.2.10 J14, EMIF/UPI DC Interface

Table 9: J14, EMIF/UPI DC Interface

Pin	Signal	Pin	Signal
2	Ground	1	Ground
4	EM_D0	3	EM_D1
6	EM_D2	5	EM_D3
8	EM_D4	7	EM_D5
10	EM_D6	9	EM_D7
12	Ground	11	Ground
14	EM_D8	13	EM_D9
16	EM_D10	15	EM_D11
18	EM_D12	17	EM_D13
20	EM_D14	19	EM_D15
22	Ground	21	Ground
24	EM_WAIT	23	EM_CLK
26	Ground	25	Ground
28	EM_CE0	27	EM_ADV
30	Ground	29	Ground
32	EM_CE1	31	EM_WE
34	Ground	33	Ground
36	EMIF_SEL	35	EM_OE
38	Ground	37	Ground
40	EM_BA0	39	EM_BA1
42	EM_A0	41	EM_A1
44	EM_A2	43	EM_A3
46	EM_A4	45	EM_A5
48	Ground	47	Ground
50	EM_A6	49	EM_A7
52	EM_A8	51	EM_A9
54	EM_A10	53	EM_A11
56	EM_A12	55	EM_A13
58	VCC_3V3	57	VCC_3V3
60	VCC_5V	59	VCC_5V

3.2.11 J8, Y Component Video In, RCA Jack (Green)

J8 is an RCA jack used as a Y component input to the THS7353, U15, pin 3. The figure below shows this connector as viewed from the card edge.

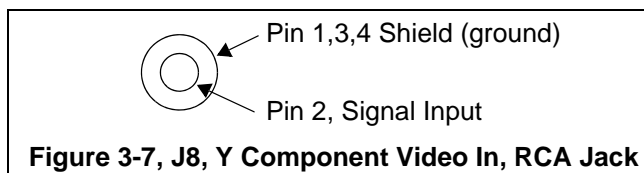

Table 10: J8, Y Component Video In, RCA Jack

Pin #	Signal Name
1	TVP_AGND
2	CH2-INA, U15, Pin 3
3	TVP_AGND
4	TVP_AGND

3.2.12 J9, Pb Component Video In, RCA Jack (Blue)

J9 is an RCA jack used as a Pb component input to the THS7353, U15, pin 4. The figure below shows this connector as viewed from the card edge.

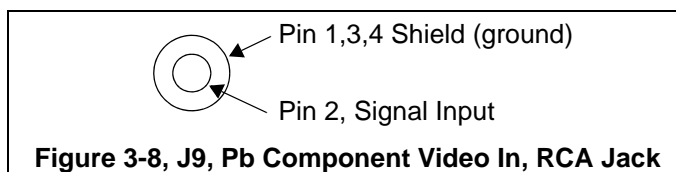

Table 11: J9, Pb Component Video In, RCA Jack

Pin #	Signal Name
1	TVP_AGND
2	CH3-INA, U15, Pin 4
3	TVP_AGND
4	TVP_AGND

3.2.13 J11, Pr Component Video In, RCA Jack (Red)

J11 is an RCA jack used as a Pr component input to the THS7353, U15, pin 2. The figure below shows this connector as viewed from the card edge.

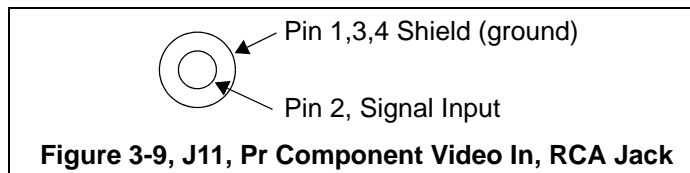

Table 12: J11, Pr Component Video In, RCA Jack

Pin #	Signal Name
1	TVP_AGND
2	CH1-INA, U15, Pin 2
3	TVP_AGND
4	TVP_AGND

3.2.14 J15, S-Video In

Connector J15 is a four pin mini din connector which interfaces to the TVP5146 encoder, U24. This connector brings in a video signal (LUMA) to pin 9 on the TVP5146. Do **NOT** plug into this connector with the power on. The figure below shows this connector as viewed from the card edge.

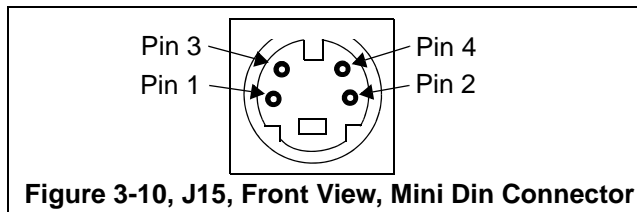

Table 13: J15, S-Video In, Mini Din Connector

Pin #	Signal Name
1	GND
2	GND
3	VI_1_C, U24, Pin 2
4	Chroma

3.2.15 J13, CVBS/Y Input, RCA Jack (Yellow)

J13 is an RCA jack used as the CVBS/Y input to the TVP5146. The figure below shows this connector as viewed from the card edge.

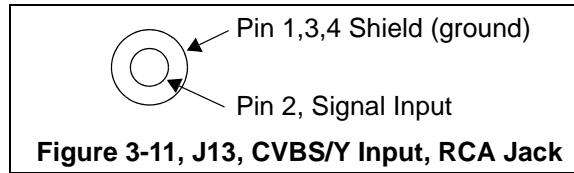

Table 14: J13, CVBS/Y Input, RCA Jack

Pin #	Signal Name
1	DEC_GND
2	VI_2_B, U24, Pin 8, TVP5146
3	DEC_GND
2	DEC_GND

3.2.16 J16, Composite TV Out, RCA Jack (Yellow)

J16 is an RCA jack used as a TV output from the DM368. This connector brings out a TV signal. The figure below shows this connector as viewed from the card edge.

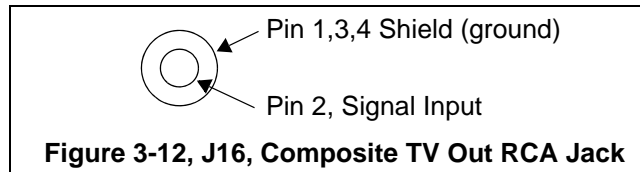

Table 15: J16, Composite TV Out, RCA Jack

Pin #	Signal Name
1	DEC_GND
2	U18-3, Pin A10
3	DEC_GND
2	DEC_GND

3.2.17 J17, Y Component Video Out, RCA Jack (Green)

J17 is an RCA jack used as a green component output from the THS7303 DAC, U23, pin 17, signal CH2-OUT. The figure below shows this connector as viewed from the card edge.

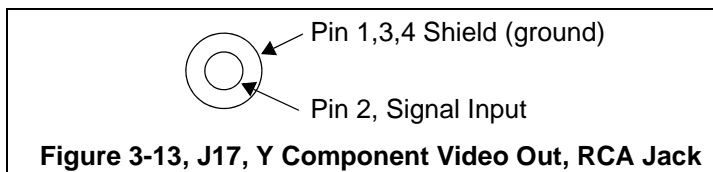

Figure 3-13, J17, Y Component Video Out, RCA Jack

Table 16: J17, Y Component Video Out, RCA Jack

Pin #	Signal Name
1	DENC_GND
2	THS7303 DAC, U23, pin 17, signal CH2-OUT
3	DENC_GND
4	DENC_GND

3.2.18 J20, Pb Component Video Out, RCA Jack (Blue)

J20 is an RCA jack used as a Pb component output from the THS7303 DAC, U23, pin 15, signal CH3-OUT. The figure below shows this connector as viewed from the card edge.

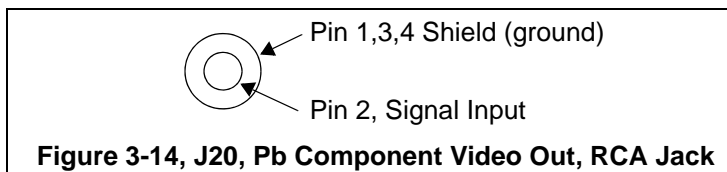

Figure 3-14, J20, Pb Component Video Out, RCA Jack

Table 17: J20, Pb Component Video Out, RCA Jack

Pin #	Signal Name
1	DENC_GND
2	THS7303 DAC, U23, pin 15, signal CH3-OUT
3	DENC_GND
2	DENC_GND

3.2.19 J21, Pr Component Video Output, RCA Jack (Red)

J21 is an RCA jack used as a Pr component output from the THS7303 DAC, U23, pin 19, signal CH1-OUT. The figure below shows this connector as viewed from the card edge.

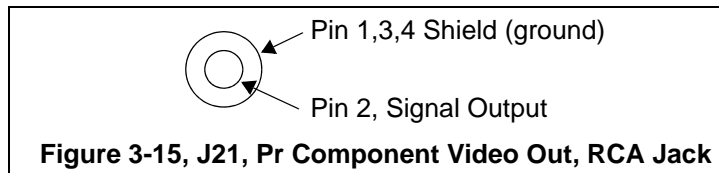

Table 18: J21, Pr Component Video Out, RCA Jack

Pin #	Signal Name
1	DENC_GND
2	THS7303 DAC, U23, pin 19, signal CH1-OUT
3	DENC_GND
4	DENC_GND

3.2.20 J18, J19, Video Output DC

Connectors J18 and J19 make up the interface to the video output DC interface. The signals on each of these connectors are shown in the tables below.

Table 19: J18, Video Output DC

Pin	Signal	Pin	Signal
1	BL_6V6	2	LCD_3V3
3	BL_6V6_RTN	4	LCD_3V3
5	Ground	6	Ground
7	VDOUT_VSYNC	8	VDOUT_LCD_OE
9	Ground	10	LCD_V5
11	VDOUT_HSYNC	12	LCD_V5
13	Ground	14	Ground
15	VDOUT_VCLK	16	VDOUT_FIELD
17	Ground	18	15V_LCD
19	BAT_VIN	20	15V_LCD
21	BAT_VIN	22	Ground
23	SPI1_SDI	24	VDOUT_EXTCLK
25	SPI1_SDENA0	26	I2C_DATA
27	SPI1_SDO	28	I2C_SCLK
29	SPI_SCLK	30	Ground

Table 20: J19, Video Output DC

Pin	Signal	Pin	Signal
1	VDOUT_Y0	2	VDOUT_C0
3	R1_GIO33	4	Ground
5	VDOUT_Y1	6	VDOUT_C1
7	R1_GIO32	8	Ground
9	VDOUT_Y2	10	VDOUT_C2
11	R1_GIO30	12	Ground
13	VDOUT_Y3	14	VDOUT_C3
15	Ground	16	Ground
17	VDOUT_Y4	18	VDOUT_C4
19	Ground	20	Ground
21	VDOUT_Y5	22	VDOUT_C5
23	Ground	24	Ground
25	VDOUT_Y6	26	VDOUT_C6
27	Ground	28	Ground
29	VDOUT_Y7	30	VDOUT_C7

3.2.21 J22, CPLD Programming Header

The J22, CPLD programming header, is for use by the factory. This header is not intended to be used outside the factory. The signals on this header are shown in the table below.

Table 21: J22, CPLD Programming Header

Pins	Signal	Pins	Signal
1	ISR_TCK	2	Ground
3	ISR_TDO	4	VCC_3V3
5	ISR_TMS	6	NC
7	NC	8	NC
9	ISR_TDI	10	Ground

3.2.22 J23, I/O Interface Header

Connector J23 is an I/O interface header allowing the user to connect external logic to interface with the I/O pins on the CPLD U33. The signals on this header are shown in the table below.

Table 22: J23, I/O Interface Header

Pins	Signal	Pins	Signal
2	VCC_1V8	1	VCC_1V8
4	NC	3	NC
6	CPLD.CONN_GIO6	5	CPLD.CONN_GIO7
8	CPLD.CONN_GIO16	7	CPLD.CONN_GIO17
10	CPLD.CONN_GIO54	9	CPLD.CONN_GIO67
12	CPLD.CONN_GIO65	11	CPLD.CONN_GIO31
14	CPLD.CONN_GIO63	13	CPLD.CONN_GIO64
16	CPLD.CONN_GIO62	15	CPLD.CONN_GIO61
18	CPLD.CONN_GIO60	17	CPLD.CONN_GIO59
20	CPLD.CONN_GIO58	19	CPLD.CONN_GIO57
22	CPLD.CONN_GIO56	21	CPLD.CONN_GIO32
24	NC	23	NC
26	NC	25	NC
28	CPLD.CONN_RESETn	27	NC
30	Ground	29	Ground

3.2.23 J24, DILC Host Connector

J24 is the DILC Host Connector. The signals on this connector are shown in the table below.

Table 23: J24, DILC Host Connector

Pins	Signal
1	CAM_PWR
2	CAM_PWR
3	SPI2_SCLK_DILC
4	Ground
5	SPI2_SDO_DILC
6	Ground
7	SPI2_SDI_DILC
8	Ground
9	LINEOUT
10	AVJ_DET
11	TP53
12	TP53
13	GIO_DILC_CHG_CTL
14	CD1
15	CD2
16	VBUS1
17	TP54
18	Ground
19	TVOUT
20	Ground
MP1	Ground
MP2	Ground

3.2.24 J25, MMC/SD Connector

The J25 MMC/SD connector is located on the bottom side of the board and is used to provide an interface to a MMC/SD card. The pinout for the J25 connector is shown in the table below.

Table 24: J25, MMC/SD Connector

Pin #	Signal	Pin #	Signal
1	CONN_SD1_DATA3	2	CONN_SD1_CMD
3	GND	4	VCC_3V3
5	CONN_SD1_CLK	6	GND
7	CONN_SD1_DATA0	8	CONN_SD1_DATA1
9	CONN_SD1_DATA2	10	WP, VCC_3V3
11	GND	12	CARD_DETECT

3.2.26 P1, RS-232 UART

The P1 connector is a 9 pin male D-connector which provides a UART interface to the EVM. This connector interfaces to the MAX 3221 RS-232 line driver (U3) and is located on the top side of the board. A view of the connector from the card edge is shown in the figure below. The signals present on this connector are defined in the following table.

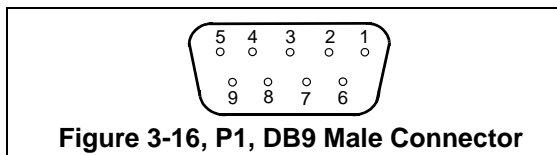

The pin numbers and their corresponding signals are shown in the table below. This corresponds to a standard dual row to DB-9 connector interface used on personal computers.

Table 25: P1, RS-232 UART Pinout

Pin #	Signal Name
1	NC
2	R_IN, U3, Pin 8
3	T_OUT, U3, Pin 13
4	NC
5	GND
6	NC
7	Pin 8
8	Pin 7
9	NC

3.2.27 P2, Ethernet Interface

The P2 connector is located on the top side of the board and is used to provide an Ethernet interface. P2 integrates the magnetics and standard RJ-45 connector. The two tables below show the signals present on the magnetics interface and the connector side.

Table 26: P2, Magnetics/LEDs Interface Signals

Pin #	Signal	Pin #	Signal
1	TX+, U5, Pin 41	2	TX-, U5, Pin 40
3	RX+, U5, Pin 33	4	VDD_3V3A
5	VDD_3V3A	6	RX-, U5, Pin 32
7	NC	8	GND_E_NET
9	VCC_3V3A	10	EPHY_LED2
11	VCC_3V3A	12	EPHY_LED0

The ethernet connector incorporates 2 LEDs which give link and transmit status from the ethernet controller.

Table 27: P2, RJ-45 Connector

Pin #	Signal	Pin #	Signal
1	TXD+	2	TXD-
3	RXD+	4	TXD-CT
5	RXD-CT	6	RXD-
7	NC	8	GND
9	LED1+	10	LED1-
11	LED2+	12	LED2-

3.2.28 P3, Microphone In

The microphone input, P3, is a 3.5 mm. stereo jack. Both inputs are connected to the microphone so it is monaural. The signal is connected to signals “MIC2R” and “MIC2L” of the TVL320AIC3101. The signals on the plug are shown in the figure below.

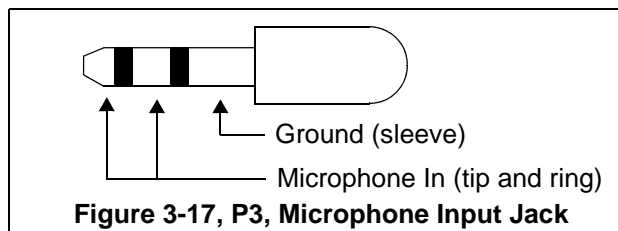

Table 28: P3, Microphone Input Jack

Pin #	Signal Name
1	GND_AIC
2	MIC2L, MIC2R, U7, Pins 14,16
3	MIC2L, MIC2R, U7, Pins 14,16
4	GND_AIC

3.2.29 P4, Line In

Connector P4 is an audio stereo line input to the TVL320AIC3101, U7, on the EVM. The input connector is a 3.5 mm stereo jack. The signals on the mating plug are shown in the figure below.

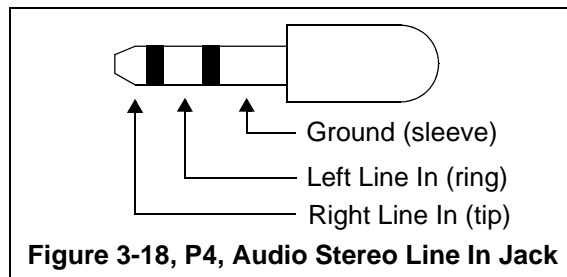

Table 29: P4, Audio Stereo Line In

Pin #	AIC3101 Signal
1	GND_AIC
2	LINE1LP, U7, Pin 10
3	LINE1RP, U7, Pin 12
4	GND_AIC

3.2.30 P5, Line Out

The connector P5, is an audio stereo output from the TVL320AIC3101, U7, on the EVM. The output connector is a 3.5 mm stereo jack. The signals on the mating plug are shown in the figure below.

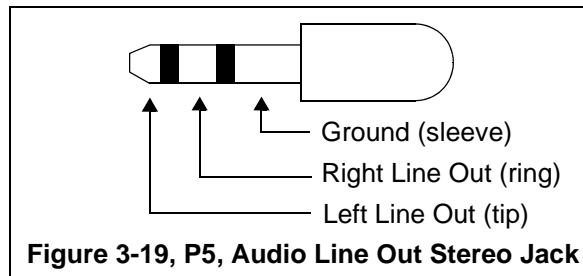

Table 30: P5, Audio Line Out Stereo Jack

Pin #	AIC3101 Signal
1	GND_AIC
2	LEFT_LO+, U7, Pin 27
3	RIGHT_LO+, U7, Pin 29
4	NC

3.2.31 P6, Headphone Out

The P6 connector is a 3.5 mm. stereo headphone output from the TVL320AIC3101, U7, on the EVM. This connector is located on the top side of the board. A view of the connector from the card edge is shown in the figure below. The signals present on this connector are defined in the following table.

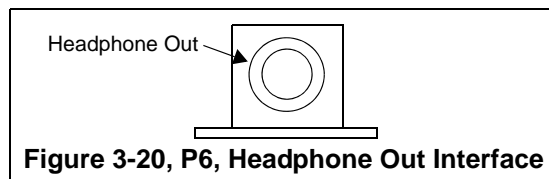
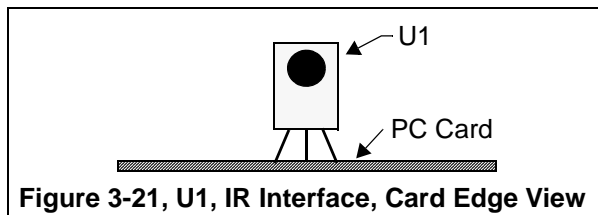

Table 31: P6, Headphone Out Interface

Pin #	AIC3101 Signal
1	GND_AIC
2	HPLOUT, U7, Pin 19
3	HPROUT, U7, Pin 23
4	NC

3.2.32 U1, Infrared Interface

U1 is an infrared receiver mounted on the edge of the board. This device interfaces to the MSP430 microcontroller. The view of U1 is shown from a board edge view in the figure below.



The receiver supports interaction with an Infrared remote control included with your EVM.

Table 32: U1, Infrared Interface

U1 Pin #	MSP430 Signal, Pin #
1	P1.2/TA1/A1+/A4-, U2, Pin 4
2	GND
3	VCC_3V3

3.2.33 SPK1, Speaker Interface

The speaker interface SPK1 provides a speaker output driven directly from the DM368 processor. The connections going to the processor are shown in the table below.

Table 33: SPK1, Speaker Interface

SPK1 Pin #	DM368 Name, Pin #
1	SPP, U18, Pin B9
2	SPN, U18, Pin A9

3.2.34 BHT1, Battery Interface

BHT1 is a holder for a BA2032SM battery. The signals on each pin are shown below in the table below.

Table 34: BHT1, Battery Interface

BHT1 Pin #	BHT1 Connection
1	VBK, U9, Pin 13
2	Ground

3.2.35 M1, Microphone Interface

The microphone interface, M1, provides a microphone input directly into the DM368 processor. The connections going to the processor are shown in the table below.

Table 35: M1, Microphone Interface

M1 Pin #	DM368 Signal Name, Pin #
1	MICIP, U18-9, Pin B8
2	MICIN, U18-9, Pin C8

3.3 LEDs

The EVM has nine (9) LEDs which are located on the top side of the board. Information regarding the LEDs are shown in the table below.

Table 36: LEDs

LED #	Schematic Page	Use	Color
DS1	52	+5 Volts present	Green
DS2	46	User control via MSP430 I ² C	Green
DS3	46	User control via MSP430 I ² C	Green
DS4	46	User control via MSP430 I ² C	Green
DS5	46	User control via MSP430 I ² C	Green
DS6	46	User control via MSP430 I ² C	Green
DS7	46	User control via MSP430 I ² C	Green
DS8	46	User control via MSP430 I ² C	Green
DS9	46	User control via MSP430 I ² C	Green

3.4 Switches

The EVM has twenty-three (23) switches. The function of these switches are shown in the table below.

Table 37: Switches

Switch	Schematic Page	Function	Type	Silkscreen
SW1	19	EMU0/EMU1 Control	2 Position DIP	
SW2	14	PRTSC ON	Push Button/Momentary	PRTSC ON
SW3	46	Non-Supported	Push Button/Momentary	RESET
SW4	3	Boot/Config Select	6 Position DIP	
SW5	21	Board Select	6 Position DIP	
SW6	45	User Readable	Push Button/Momentary	KEY2
SW7	45	User Readable	Push Button/Momentary	LEFT
SW8	45	User Readable	Push Button/Momentary	EXIT
SW9	45	User Readable	Push Button/Momentary	DOWN
SW10	45	User Readable	Push Button/Momentary	ENTER
SW11	45	User Readable	Push Button/Momentary	UP
SW12	45	User Readable	Push Button/Momentary	KEY1
SW13	45	User Readable	Push Button/Momentary	RIGHT
SW14	45	User Readable	Push Button/Momentary	MENU
SW15	45	User Readable	Push Button/Momentary	REC
SW16	45	User Readable	Push Button/Momentary	REW
SW17	45	User Readable	Push Button/Momentary	SKIP -
SW18	45	User Readable	Push Button/Momentary	STOP
SW19	45	User Readable	Push Button/Momentary	FF
SW20	45	User Readable	Push Button/Momentary	SKIP +
SW21	45	Short to Ground	Push Button/Momentary	PLAY PAUSE
SW22	44	Short to Ground	Push Button/Momentary	
SW23	47	PRTSC Mode	2 Position DIP	

3.4.1 SW1, EMU0/1 Select Switch

SW1 is a 2 position DIP switch providing 4 options in selecting the state of the EMU0 and EMU1 pins on the TMS320DM368 processor. A view of the switch is shown in the figure below. The selection options with this switch are in the table below.

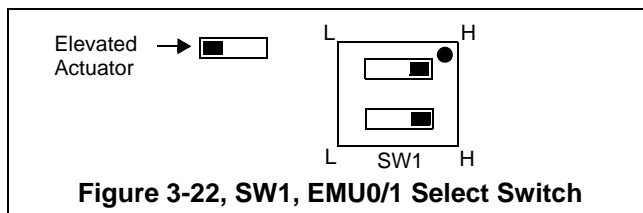

Figure 3-22, SW1, EMU0/1 Select Switch

Table 38: SW1, EMU0/1 Select

State at Reset		Function
EMU1	EMU0	
L(0)	L(0)	Reserved
L(0)	H(1)	Reserved
H(1)	L(0)	Reserved
H(1)	H(1)	ICE PICK Mode * Both ARM & DSP JTAG Enabled

* is the factory shipped configuration

3.4.2 SW2, PWCTRO0 Pushbutton

Switch SW2 is a push button momentary switch that forces the PWCTRO0 signal on the DM368, U18-11, pin J3, to ground when the switch is depressed.

3.4.3 SW3, RESET Pushbutton

Switch SW3 is a push button momentary switch that will reset the processor when depressed.

3.4.4 SW4, Boot Mode / Configuration Select

Switch SW4 is a 6 position DIP switch used to select the ARM Boot Mode and processor configuration. The first 3 positions selection the ARM boot mode. The last 3 positions select the processor configuration. The figure and tables below show these options.

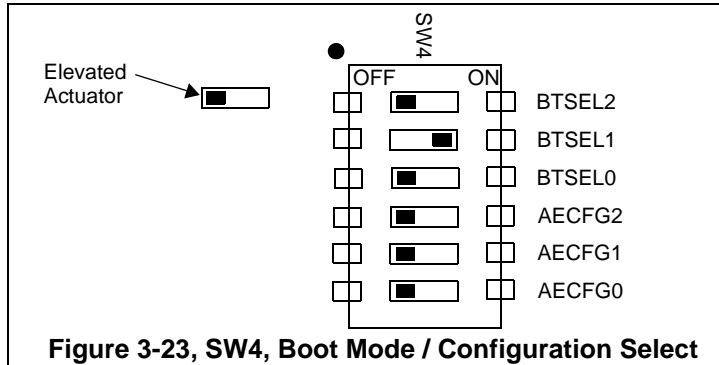

Figure 3-23, SW4, Boot Mode / Configuration Select

Table 39: SW4, Boot Mode Select

Pos 1 BTSEL2	Pos 2 BTSEL1	Pos 3 BTSEL0	HW Code	Boot Mode
OFF	OFF	OFF	0 0 0	NAND Boot
OFF	OFF	ON	0 0 1	ASYNC EMIF
OFF	ON	OFF	0 1 0	MMC/SD Boot *
OFF	ON	ON	0 1 1	UART Boot
ON	OFF	OFF	1 0 0	USB Boot
ON	OFF	ON	1 0 1	SPI Boot
ON	ON	OFF	1 1 0	EMAC Boot
ON	ON	ON	1 1 1	HPI Boot

Table 40: SW4, Configuration Select

Pos 4 AECFG2	Pos 5 AECFG1	Pos 6 AECFG0	HW Code	Configuration Mode
OFF	OFF	OFF	0 0 0	8-bit AEMIF Configuration *
ON	ON	OFF	1 1 0	16-bit AEMIF Configuration

* default setting

3.4.5 SW5, Board Configuration Select

Switch SW5 is a 6 position switch that configures specific board functions. The figure below shows the switch as it appears on the EVM.

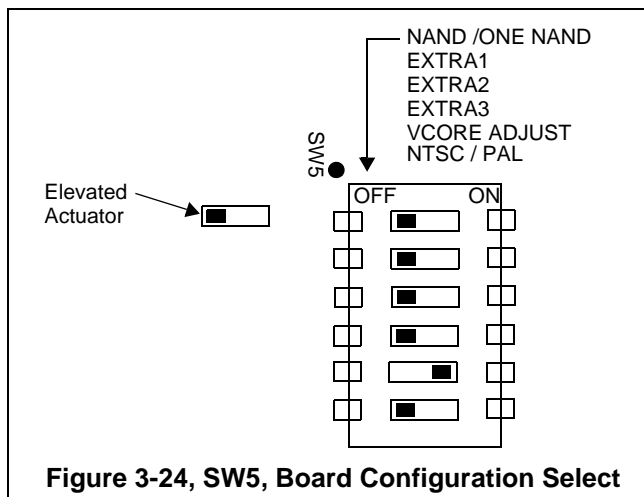

Figure 3-24, SW5, Board Configuration Select

The table below shows the function of each switch position on SW5.

Table 41: SW5, Board Configuration Select

Position	State	Bit Value	Function
1	OFF	0	SELNAND *
	ON	1	SELONENAND
2	OFF	0	Reserved *
	ON	1	Reserved
3	OFF	0	Reserved *
	ON	1	Reserved
4	OFF	0	Reserved *
	ON	1	Reserved
5	OFF	0	Vcore = 1.2 Volts
	ON	1	Vcore = 1.35 Volts *
6	OFF	0	NTSC (CPLD register bit) *
	ON	1	PAL (CPLD register bit)

* = default

3.4.6 SW6 - SW21, Function Pushbuttons

Switches SW6 through SW21 are push button momentary switches that are inputs in to the DM368 processor. These switches can be read with software and their function is determined by the application.

3.4.7 SW22, MSP430 IO0 Pushbutton

Switch SW22 is a push button momentary switch reserved for future use.

3.4.8 SW23, PRTSC Mode Select

Switch SW23 is a 2 position DIP switch that allows the user to select power control and real time clock mode on the DM368. The figure below shows the switch as it appears on the EVM.

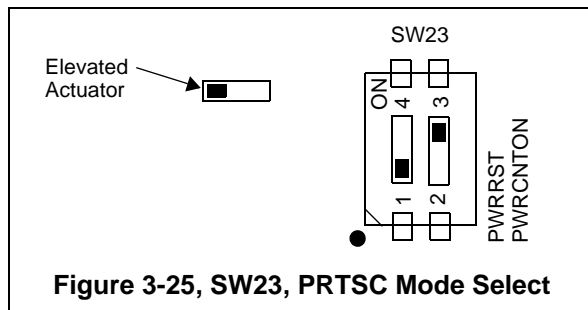

The table below shows the setting for SW23.

Table 42: SW23, PRTSC Mode Select

Position 1	Position 2	Signal Level	DM368 Mode
0	0	0 0	Reserved
0	1	0 1	RTC and GPIO available *
0	1	1 0	Reserved
0	1	1 1	Reserved

* default

3.5 Jumpers

The following section describes the jumpers on the DM368 EVM.

3.5.1 JP1, Jumper Block

Jumper block JP1, found on schematic page 39, allows the user to connect signals from the DM368 processor to the TVL320AIC3101, U7. The signals on this 9 x 2 header are shown in the table below.

Table 43: JP1, Jumper Block

Pin #	Signal Name	Pin #	Signal Name
2	AIC_McBSP_CLKX	1	AIC_BCLK, U7, Pin 2
4	AIC_McBSP_CLKR	3	AIC_BCLK, U7, Pin 2
6	AIC_McBSP_FSX	5	AIC_WCLK, U7, Pin 3
8	AIC_McBSP_FSR	7	AIC_WCLK, U7, Pin 3
10	AIC_McBSP_DX	9	AIC_DIN, U7, Pin 4
12	AIC_McBSP_DR	11	AIC_DOOUT, U7, Pin 5
14	I2C_DATA	13	SDA, U7, Pin 9
16	I2C_SCLK	15	SDL, U7, Pin 8
18	Ground	17	Ground

3.5.2 JP2, Unpopulated Jumper

Jumper JP2, found on schematic page 14, is unpopulated and not used.

3.5.3 JP28, Unpopulated Jumper

Jumper JP28, found on schematic page 14, is unpopulated and not used.

3.5.4 J26, USB ID Select

The J26 jumper is used to pull the USB_ID line on USB connector high or low. The selections are shown below.

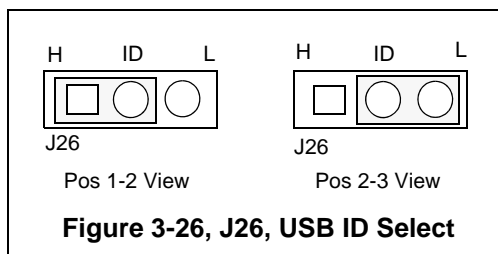

Table 44: J26, USB ID Select

Position	Function
1 - 2	USB_ID pulled high *
2 - 3	USB_ID pulled low

* Factory shipped configuration

3.5.5 J27, U14 LL8 Voltage Select

The J27 jumper is used to select the voltage input to U14, Pin 27, LL8. The selections are shown below.

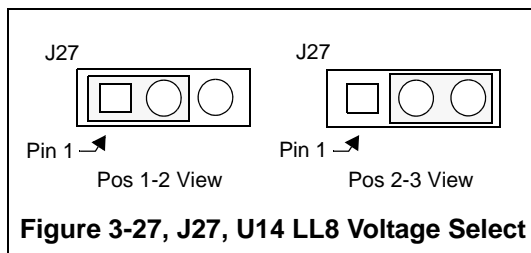

Table 45: J26, U14 LL8 Voltage Select

Position	Function
1 - 2	VCC5_IN Selected *
2 - 3	VCC_3V3 Selected

* Factory shipped configuration

3.6 Test Points

The EVM has 65 test points. The following 2 figures identify the position of each test point. The next two tables lists each test point and the signal appearing on that test point.

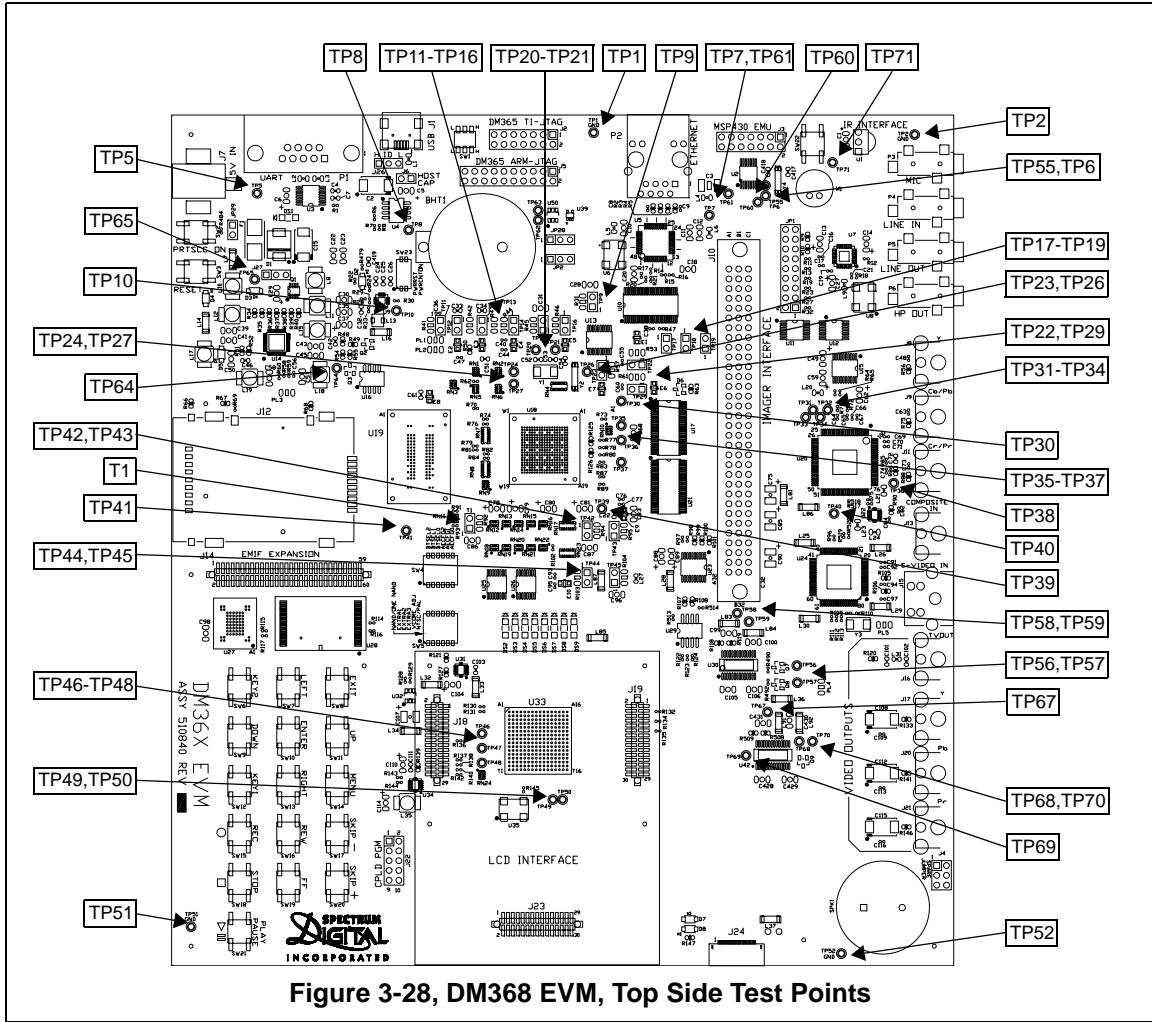

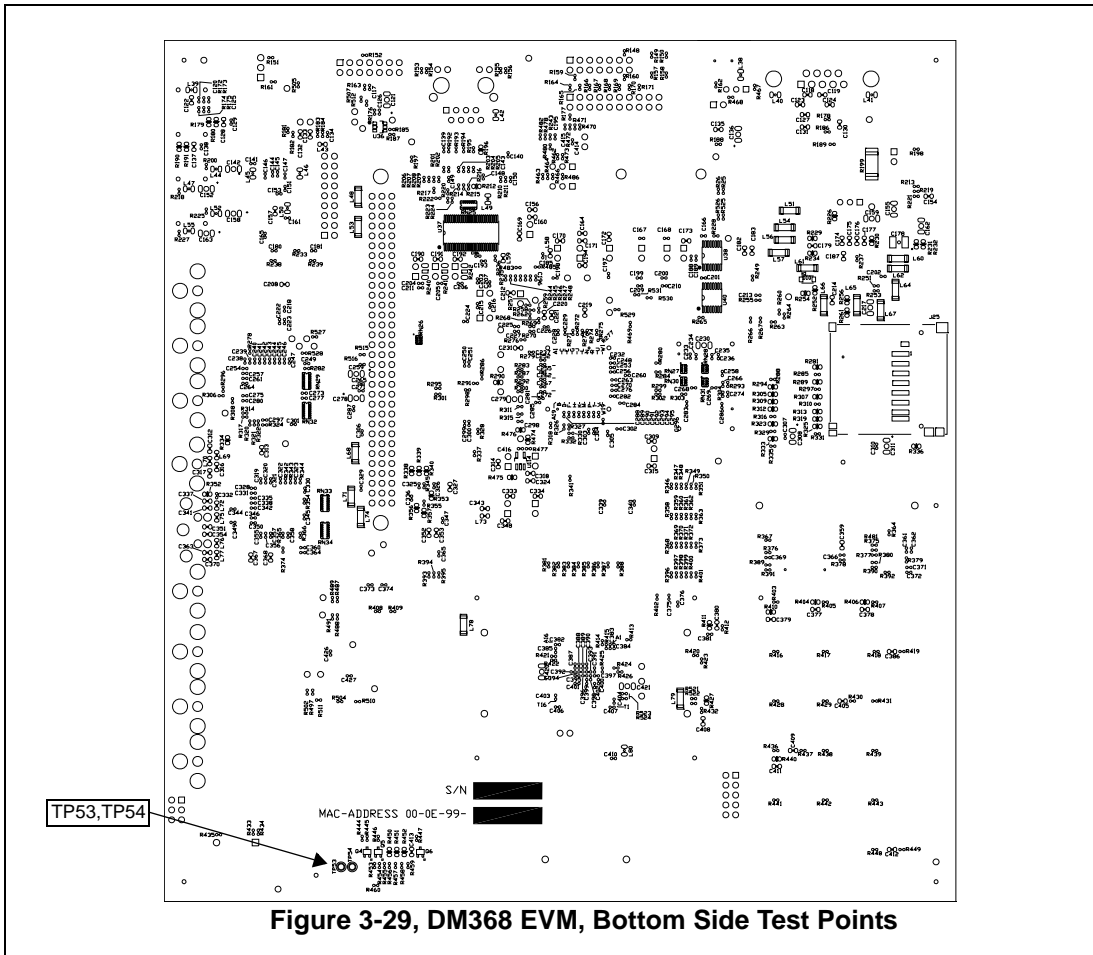

Table 46: DM368 EVM Test Points

TP #	Schematic Page	Signal	TP #	Schematic Page	
TP1	52	GND	TP46	20	U33A, F2, B1.IO_21
TP2	52	GND	TP47	23	U33D, P11, B4.IO_47
TP5	52	VCC_5V	TP48	23	U33D, P7, B4.IO_21
TP6	44	U2, Pin 6, MP430_IO2	TP49	20	U33A, M4, B1.IO_58
TP7	43	U5, Pin 25, INT#PHYAD0	TP50	20	U33A, P2, B1.IO_65
TP8	18	VCC_3V3, VBUS_OCn2, U4, Pin 5	TP51	52	GND
TP10	47	U9, Pin6, PWMON	TP52	52	GND
TP20	10	U18-13, L1, MXI1	TP53	41	J24, Pin 11,12, BAT_CHG
TP21	10	U18-13, K1, MXO1	TP54	41	J24, Pin 17
TP24	13	U18-14, R1, RSV1	TP55	44	U2, Pin 7, MP430_IO5
TP26	10	DM360 RESETn, U18-13, H3	TP56	50	CPU_VCC_3V3
TP27	13	U18-14, R4, RSV2	TP57	50	CPU_VCC_3V3
TP30	13	U18-14, A1, RSV0	TP58	50	U30, Pin 23/24, 1OUT_1/2
TP31	35	U20, Pin 24, HSOUT	TP59	50	U30, Pin 17/18, 2OUT_1/2
TP32	35	U20, Pin 22, FIDOUT	TP60	44	U2, Pin 5, MP430_IO1
TP33	35	U20, Pin 25, SOGOUT	TP61	44	U2, Pin 2, MP430_IO0
TP34	35	U20, Pin 23, VSOUT	TP64	48	U14, Pin 34, CIN
TP35	12	U18-9, C9, LINEO	TP65	48	U14, Pin 36, SW7
TP36	11	U18-10, A6, ADC_CH5	TP67	51	U42, Pin 23/24, 1OUT_1/2
TP37	11	U18-10, D7, ADC_CH4	TP68	51	U42, Pin 17/18, 2OUT1/2
TP38	35	U20, Pin 80, EXT_CLK	TP69	51	U42, Pin 4, 1EN
TP39	7	VREF, U18-3, D11	TP70	51	PWCTR_OUT1
TP40	52	GND	TP71	44	MSP430_3V3
TP41	52	GND			

There are 18 power test points on the EVM. These test points provide a convenient mechanism to check the EVM's multiple power supplies. The table below shows the voltages for each test point and what the supply is used for.

Table 47: Power Test Points

Access Test Point	Schematic Page	Voltage	Shunt	Power Domain
T1	13	+1.8V	0.02 ohms	VCC_1V8, U18-14, R12, CPU_VDD_DDR
TP9	13	+3.3V	0.02 ohms	VCC_3V3, U18-14, P5, CPU_VDDSHV
TP11	13	+1.2V	0.02 ohms	VCC_1V2, U18-14, R3
TP12	4	+3.3V	0.02 ohms	VCC_3V3
TP13	4	+1.8V	0.02 ohms	VCC_1V8
TP14	13	+1.8V	0.02 ohms	VCC_1V8, U18-14, N4
TP15	13	+1.2V	0.02 ohms	VCC_1V2, U18-14, J14, CPU_VDD
TP16	11	+1.8V	0.02 ohms	VCC_1V8, U18-10, G9
TP17	13	+1.8V	0.02 ohms	VCC_1V8, U18-14, E5
TP18	14	+1.8V	0.02 ohms	1V8_BB_UP, U18-11, K6
TP19	14	+1.2V	0.02 ohms	1V2_BB_UP, U18-11, K7,J6
TP22	12	+1.8V	0.02 ohms	VCC_1V8, U18-9, E9
TP23	10	+1.8V	0.02 ohms	VCC_1V8, U18-13, L6
TP29	12	+3.3V	0.02 ohms	VCC_3V3, U18-9, E10
TP42	13	+3.3V	0.02 ohms	VCC_3V3, U18-14, R14, CPU_VDDSHV10
TP43	7	+1.8V	0.02 ohms	VCC_1V8, U18-3, D10
TP44	7	+1.2V	0.02 ohms	VCC_1V2, U18-3, E12
TP45	13	+1.2V	0.02 ohms	VCC_1V2, U18-14, M14, CPU_VDDS

Appendix A

Schematics

This appendix contains the schematics for the DM368 EVM.

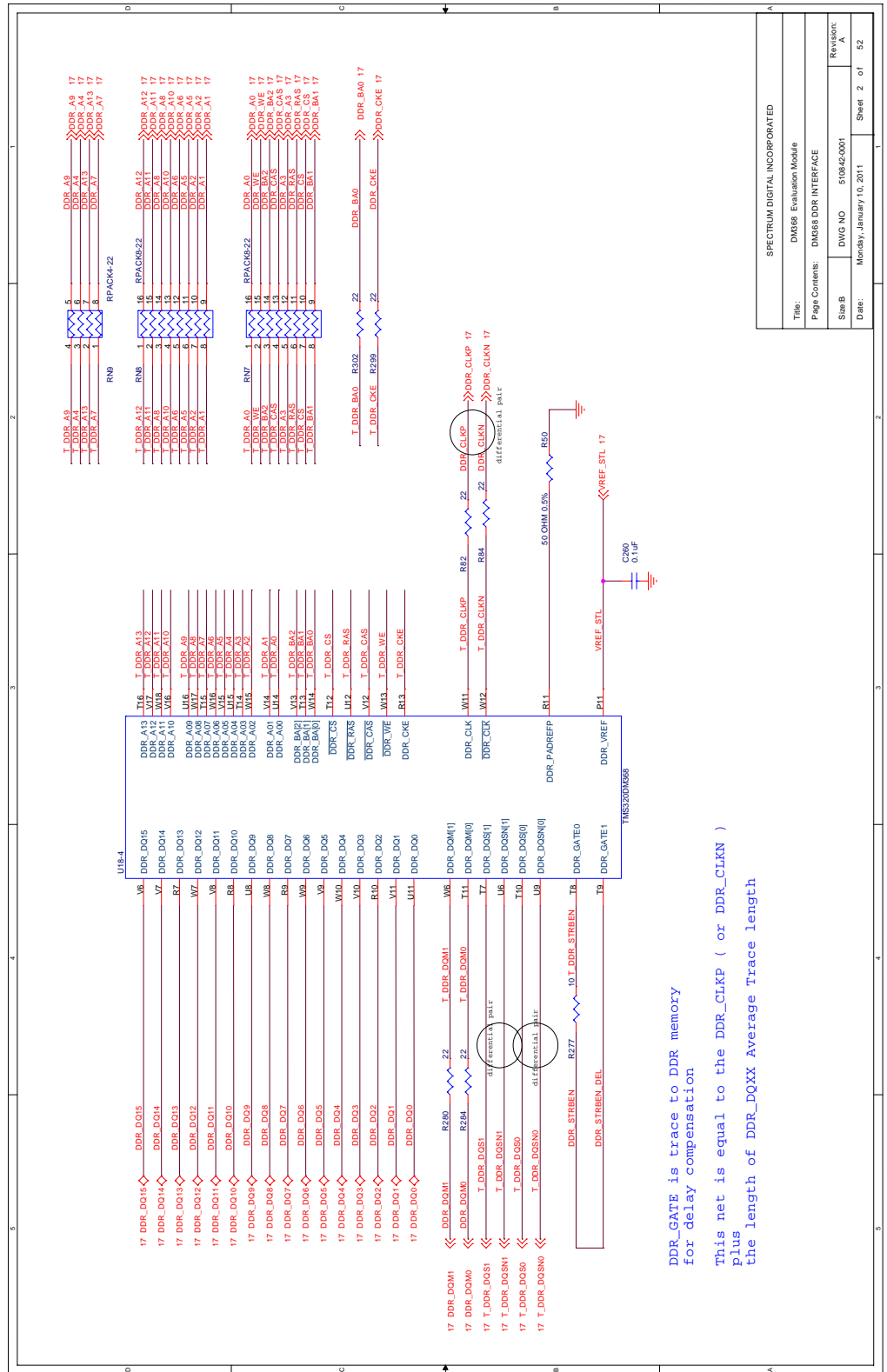

SPECTRUM DIGITAL INCORPORATED	
Title:	DM868 Evaluation Module
Page Contents:	DM868 DDR INTERFACE
Sheet B	DWG NO 510842-0001
Date:	Monday, January 10, 2011
Revision:	A
Sheet 2 of 52	

DDR_GATE is trace to DDR memory for delay compensation
 This net is equal to the DDR_CLKP (or DDR_CLKN) plus the length of DDR_DQXX Average Trace length

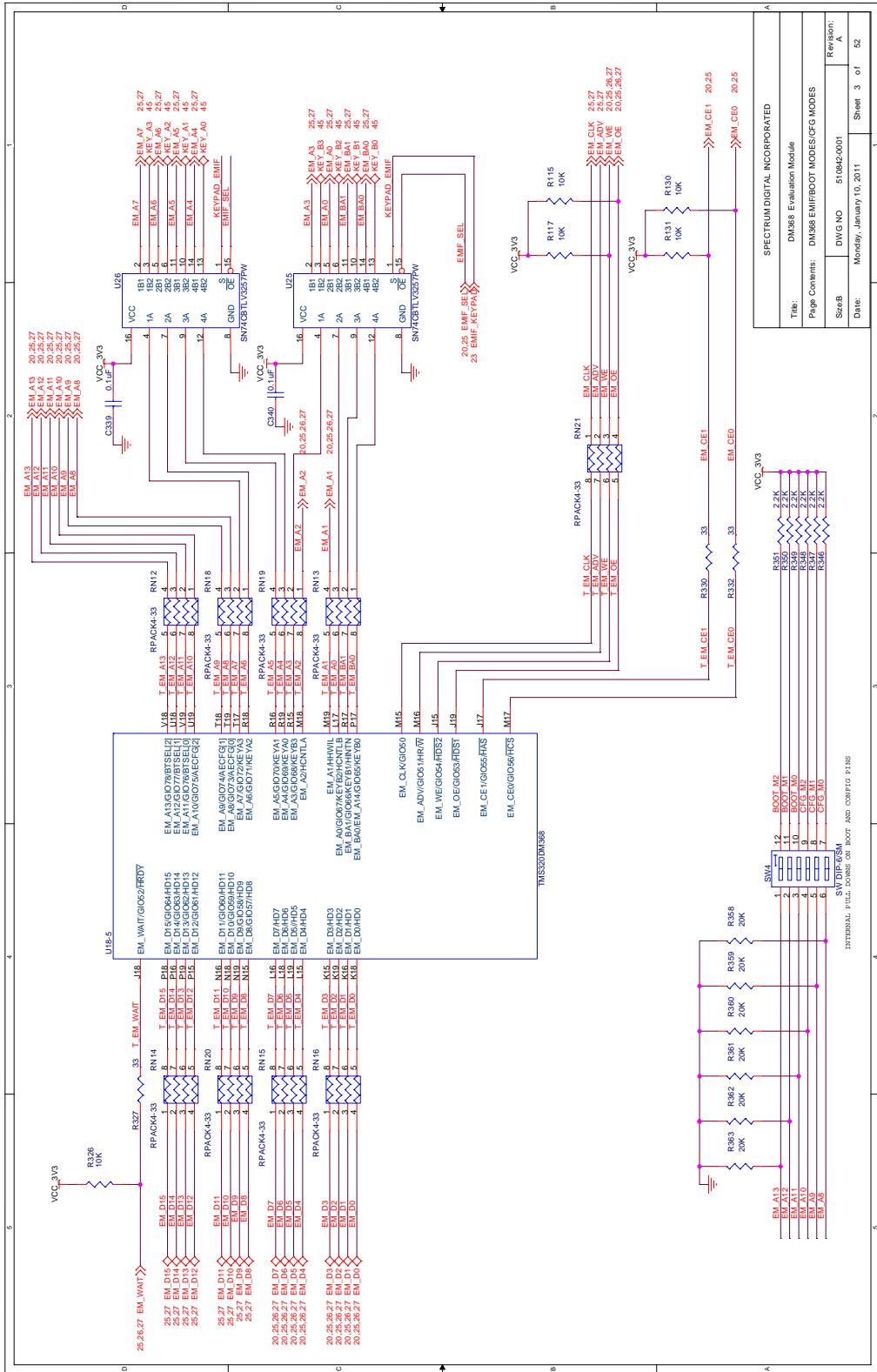

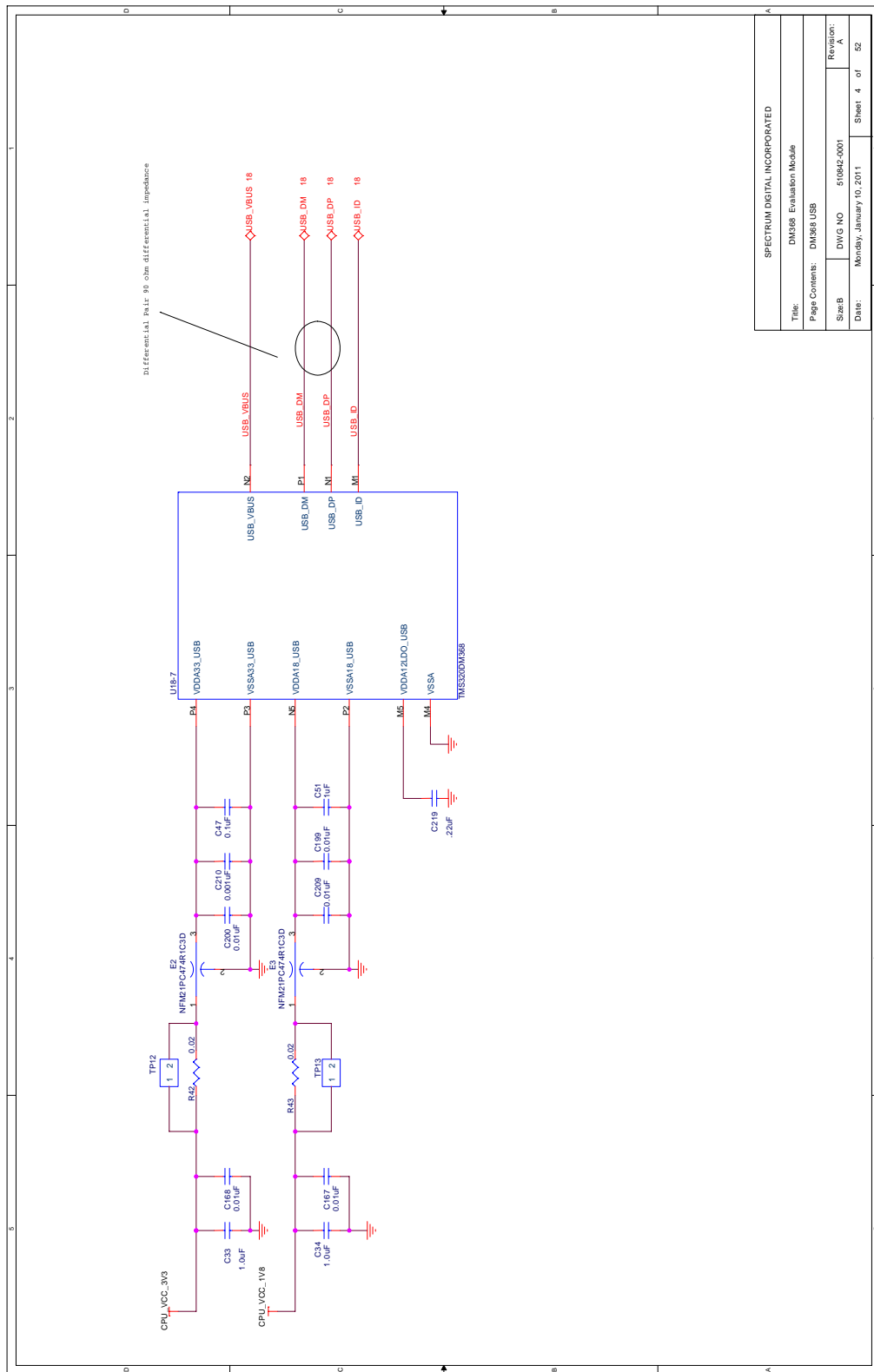

SPECTRUM DIGITAL INCORPORATED	
Title:	DM368 Evaluation Module
Page Contents:	DM368 USB
Sheet:	DM368 USB
Revision:	510842-001
Date:	Monday, January 10, 2011
Sheet	4 of 52

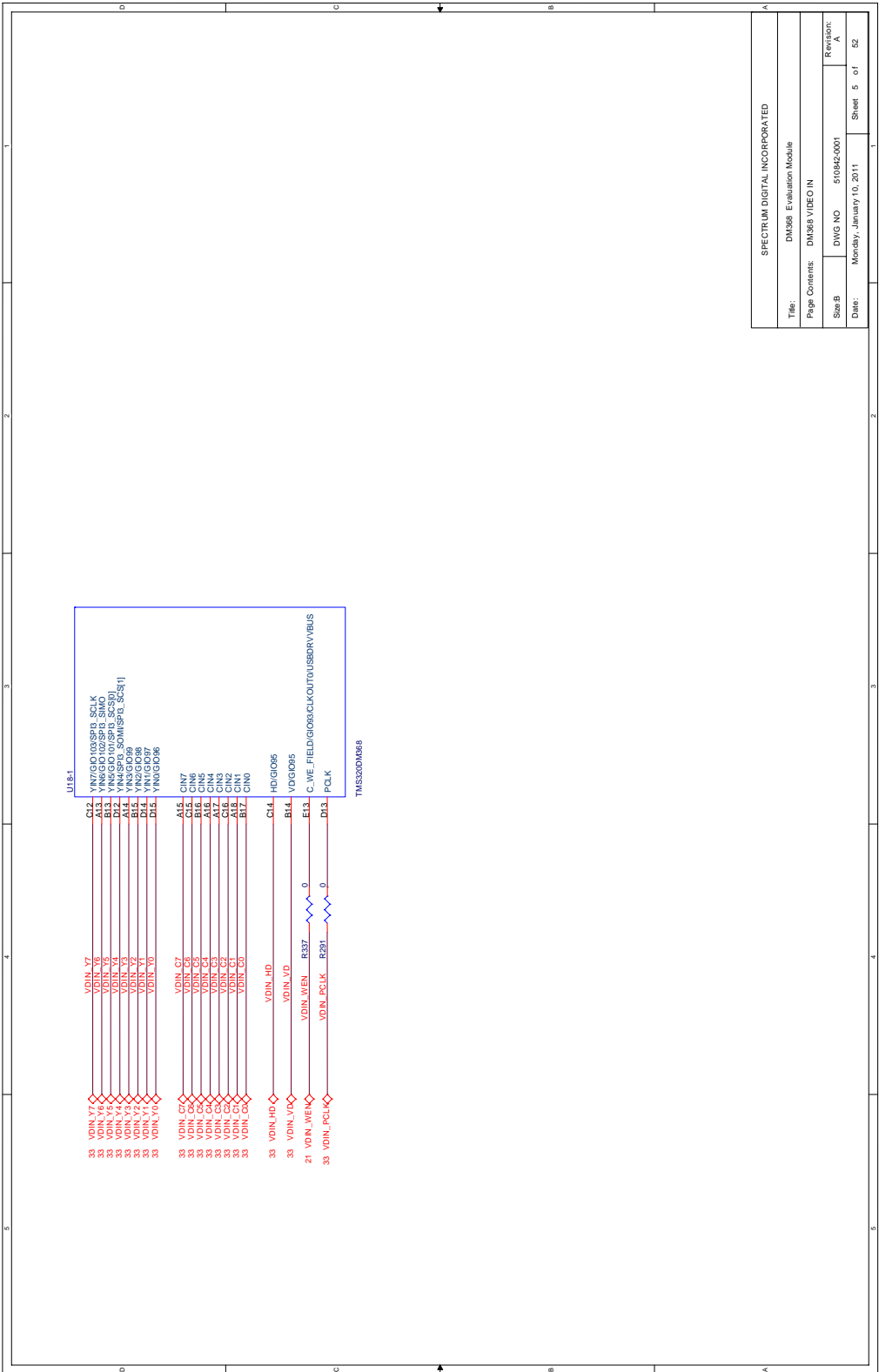

SPECTRUM DIGITAL INCORPORATED	
Title:	DM368 Evaluation Module
Page Contents:	DM368 VIBCO IN
Size B	DWG NO 510842-0001
Date:	Monday, January 10, 2011
Revision:	A
Sheet:	5 of 52

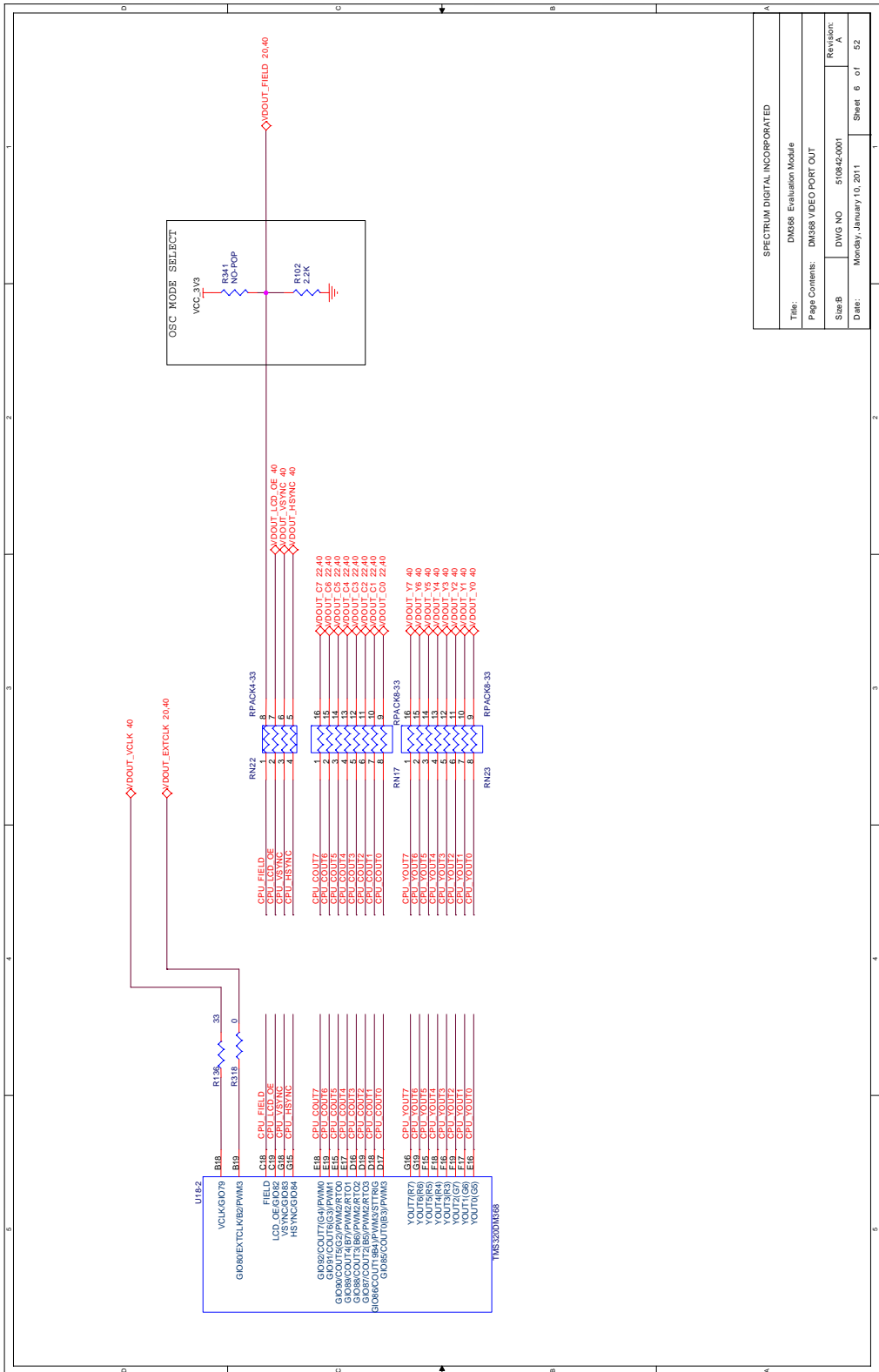

SPECTRUM DIGITAL INCORPORATED			
File: DM568 Evaluation Module			
Page Contents: DM388 VBE0 PORT OUT			
Size: B	DWG NO: 510842-001	Revision: A	
Date: Monday, January 10, 2011	Sheet 6 of 52		

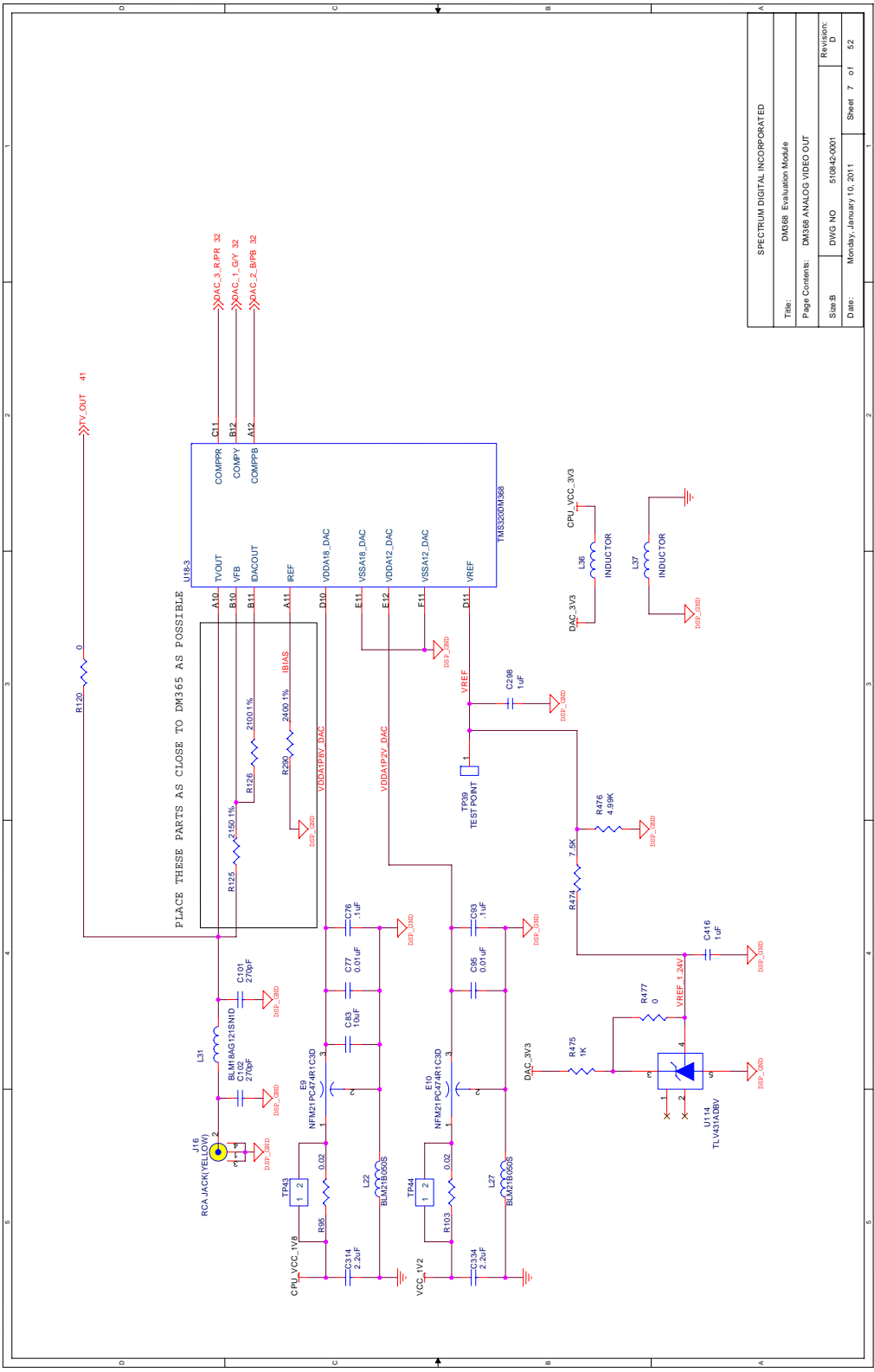

SPECTRUM DIGITAL INCORPORATED	
Title:	DM368 Evaluation Module
Page Contents:	DM368 ANALOG VIDEO OUT
Size:	DWG NO. 510842-001
Revision:	0
Date:	Monday, January 10, 2011
Sheet 7 of 52	

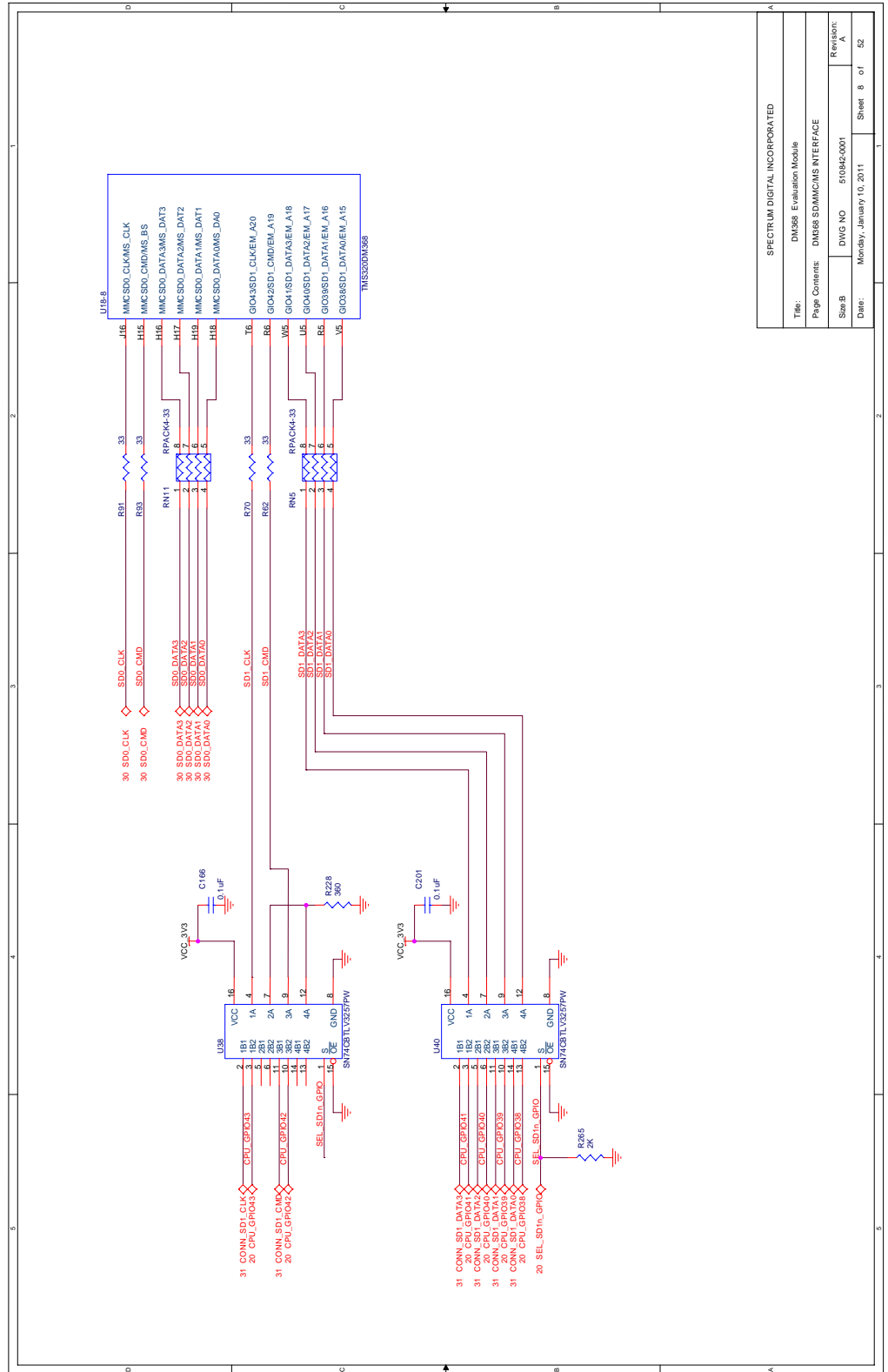

SPECTRUM DIGITAL INCORPORATED	
File:	DM368 Evaluation Module
Page Contents:	DM368 SDMMC/MS INTERFACE
Size:	DWG NO 510842-001
Date:	Monday, January 10, 2011
Revision:	A
Sheet:	8 of 52

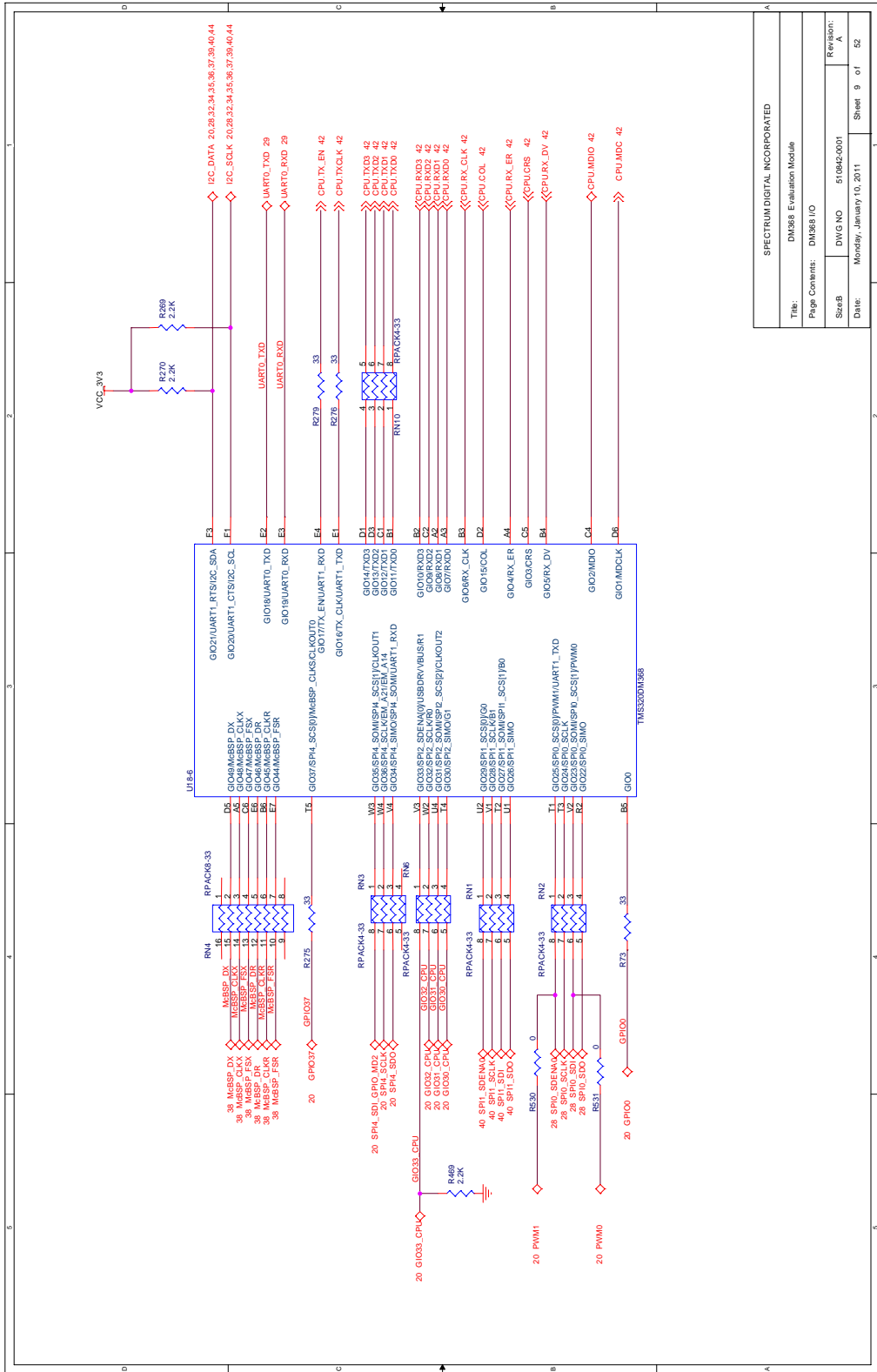

SPECTRUM DIGITAL, INCORPORATED	
Title:	DM368 Evaluation Module
Page Comments:	DM368 IO
Size/B	DWG NO 510842-0001
Date:	Monday, January 10, 2011
Revision:	A
Sheet	9 of 52

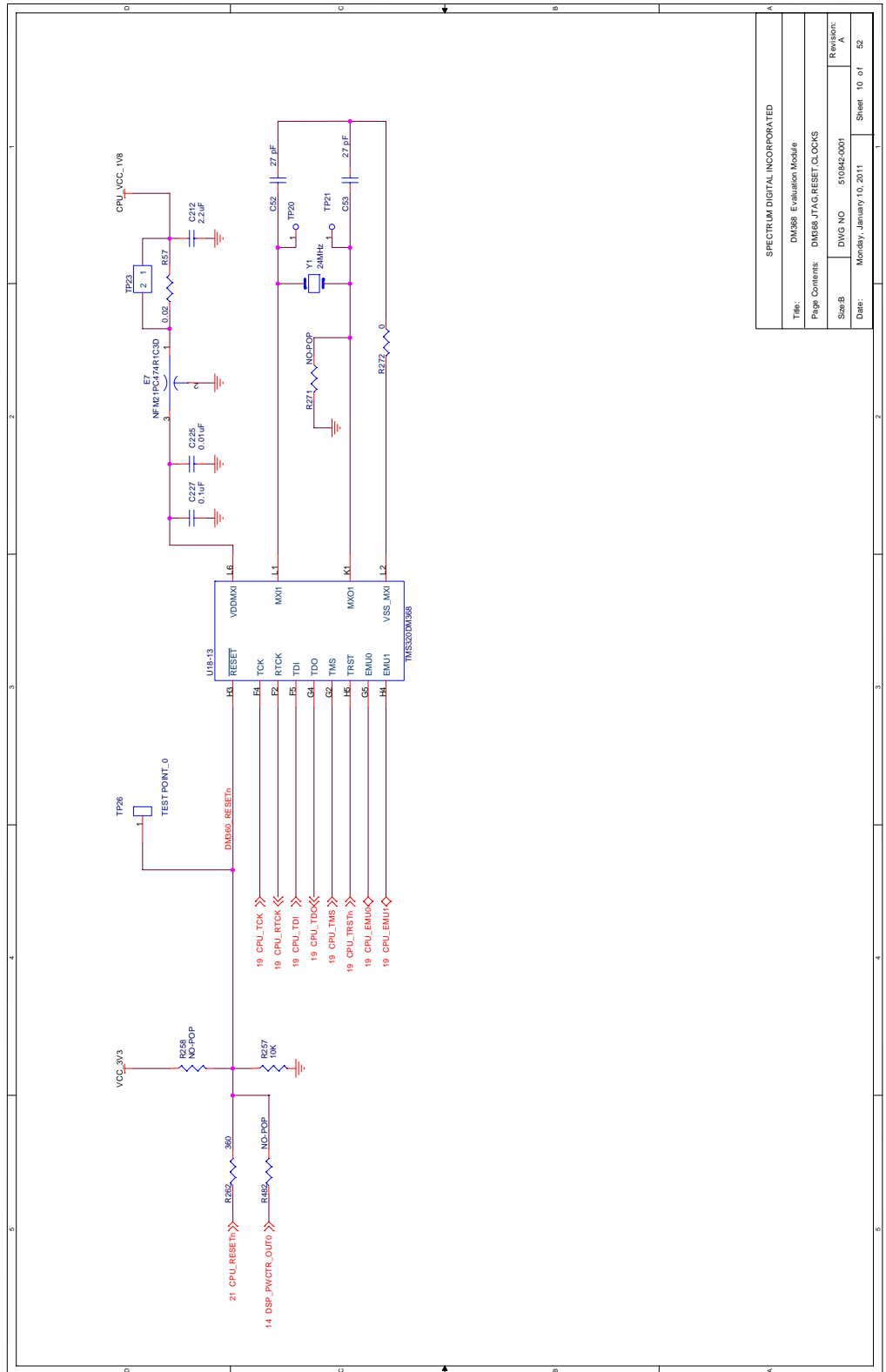

SPECTRUM DIGITAL INCORPORATED	
Title:	DM368 Evaluation Module
Page Contents:	DM368 JTAG, RESET, CLOCKS
Size B	Revision: A
Date:	Monday, January 10, 2011
Sheet:	10 of 52

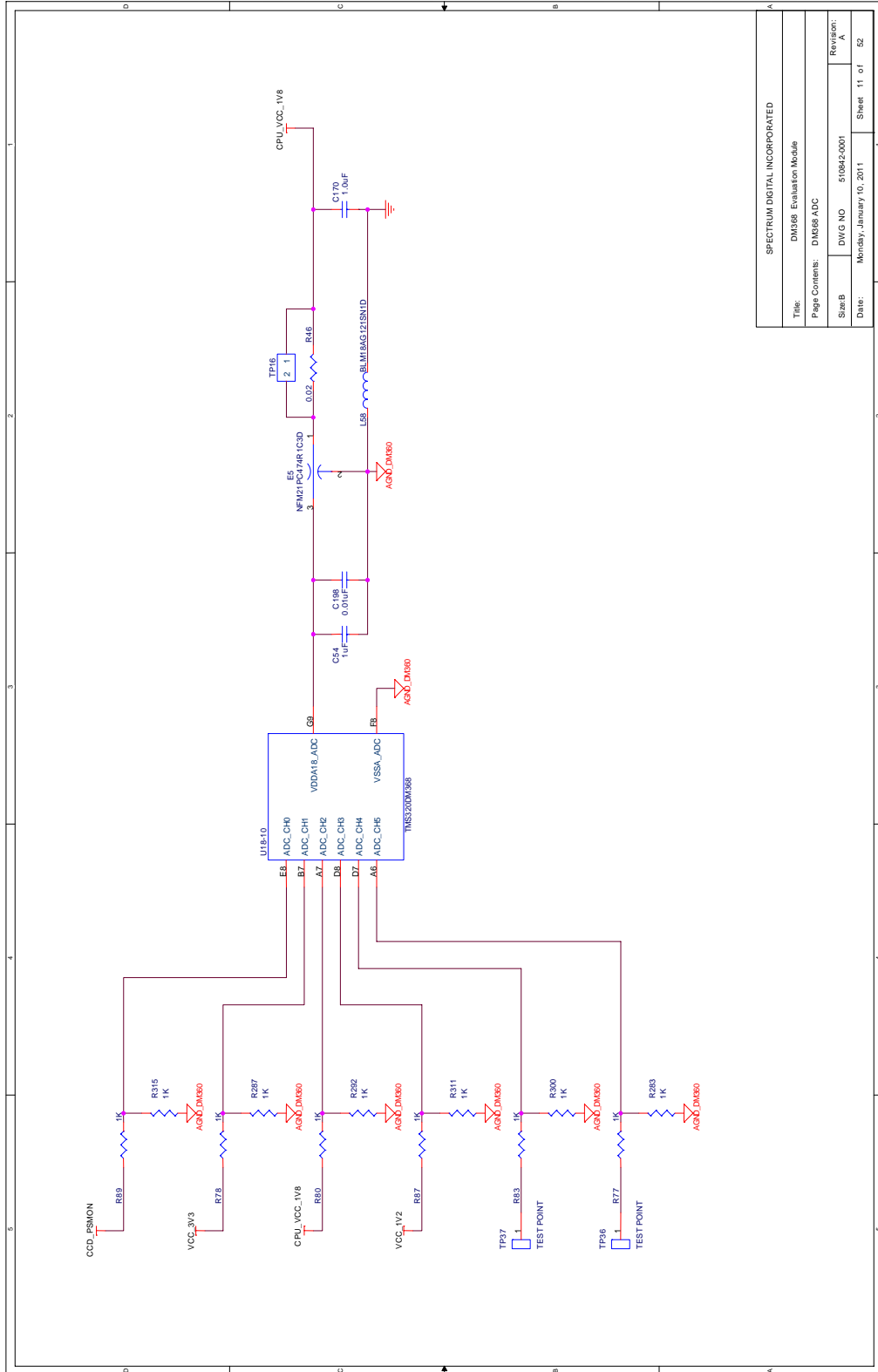

SPECTRUM DIGITAL INCORPORATED	
Title:	DM368 Evaluation Module
Page Contents:	DM368 ADC
Size/B	DWG NO. 510642001
Revision:	A
Date:	Monday, January 10, 2011
Sheet 11 of 52	

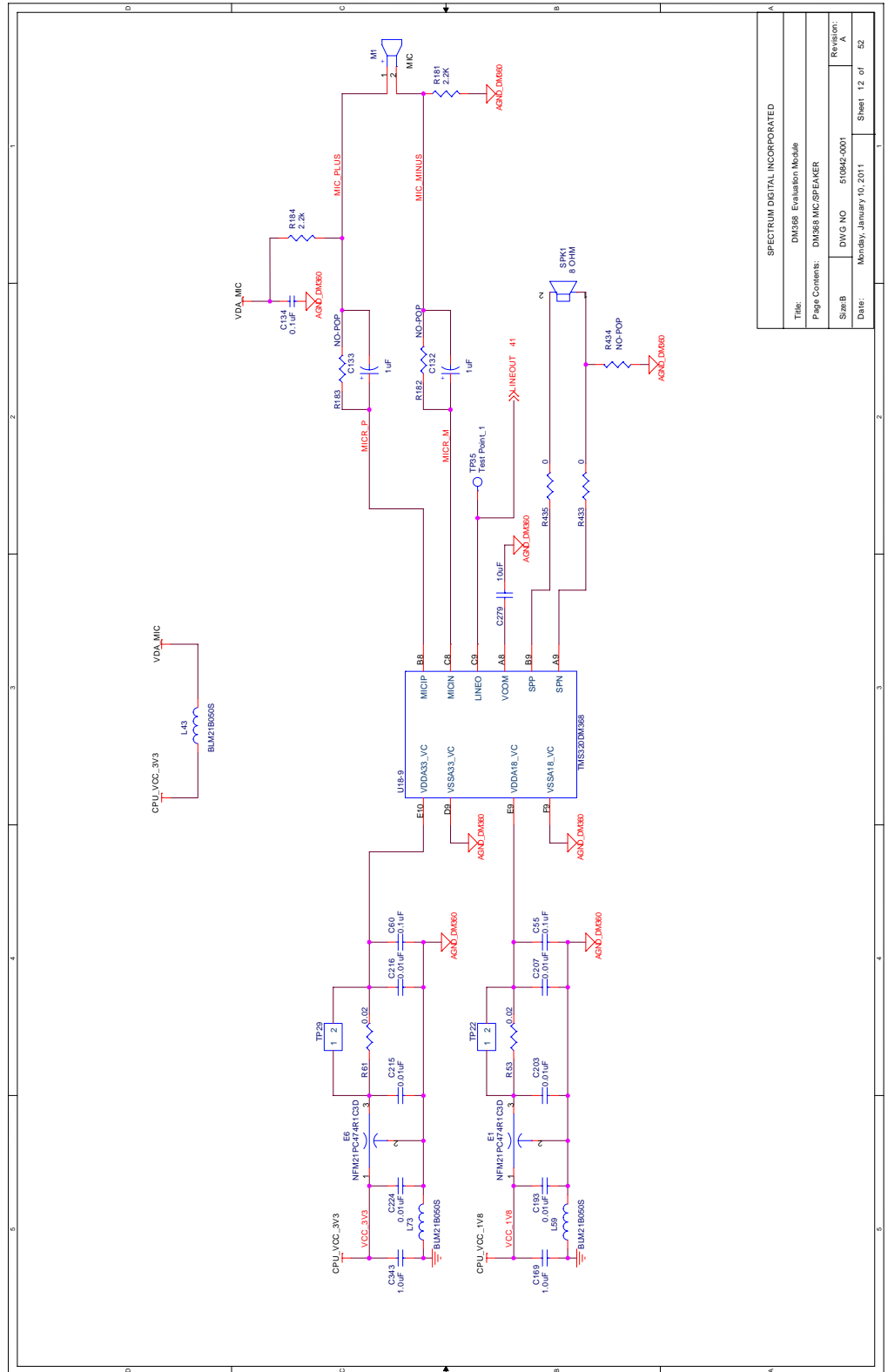

SPECTRUM DIGITAL INCORPORATED			
Title:	DM088 Evaluation Module		
Page Contents:	DM088 MIC/SPEAKER		
Sheet:	DMG NO	510842-001	Revision:
Date:	Monday, January 10, 2011	Sheet 12 of 52	A

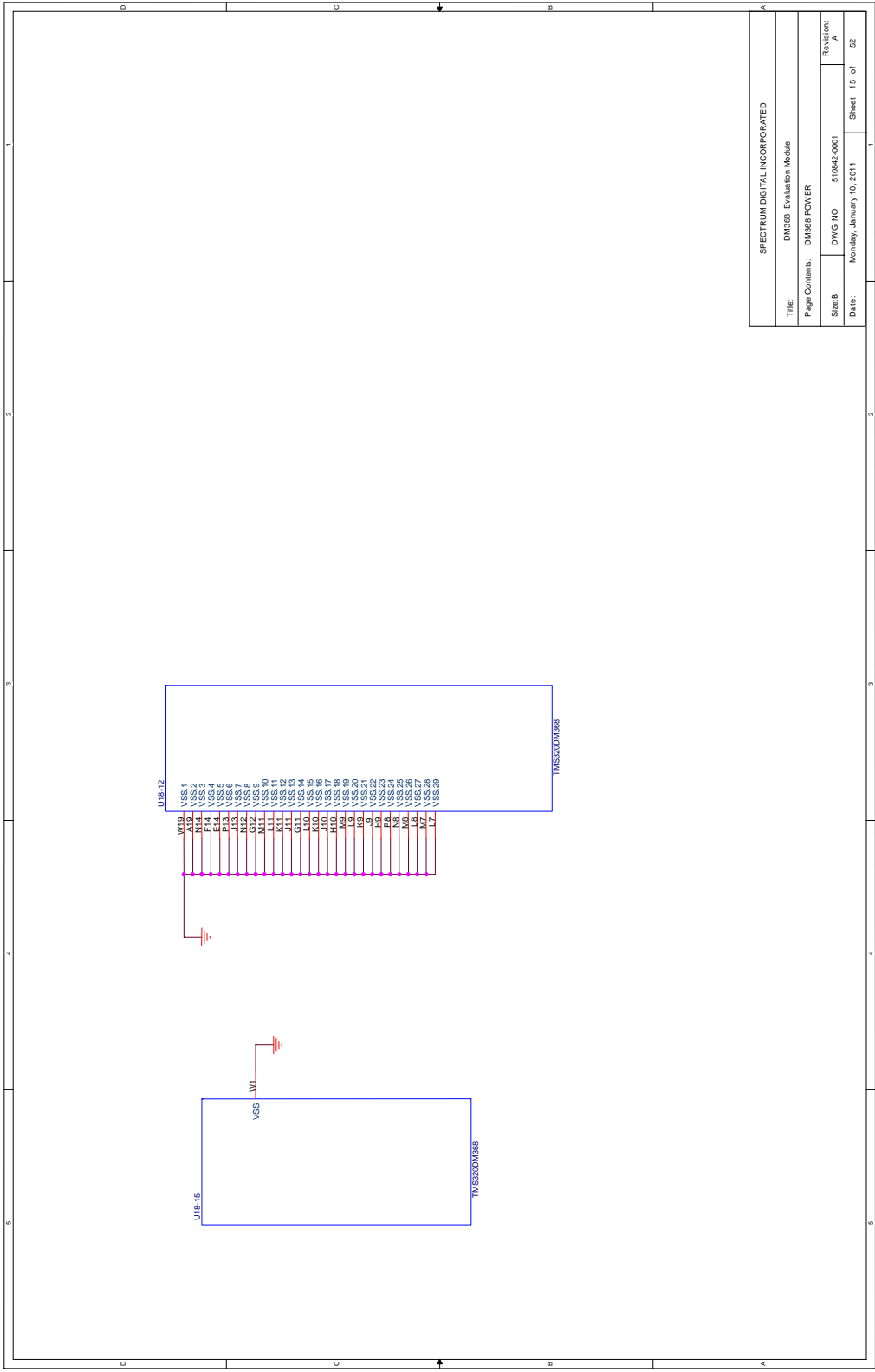

SPECTRUM DIGITAL INCORPORATED	
Title:	DM368 Evaluation Module
Page Contents:	DM368 POWER
Sheet:	510842-0001
Date:	Monday, January 10, 2011
Revision:	A
Sheet	15 of 52

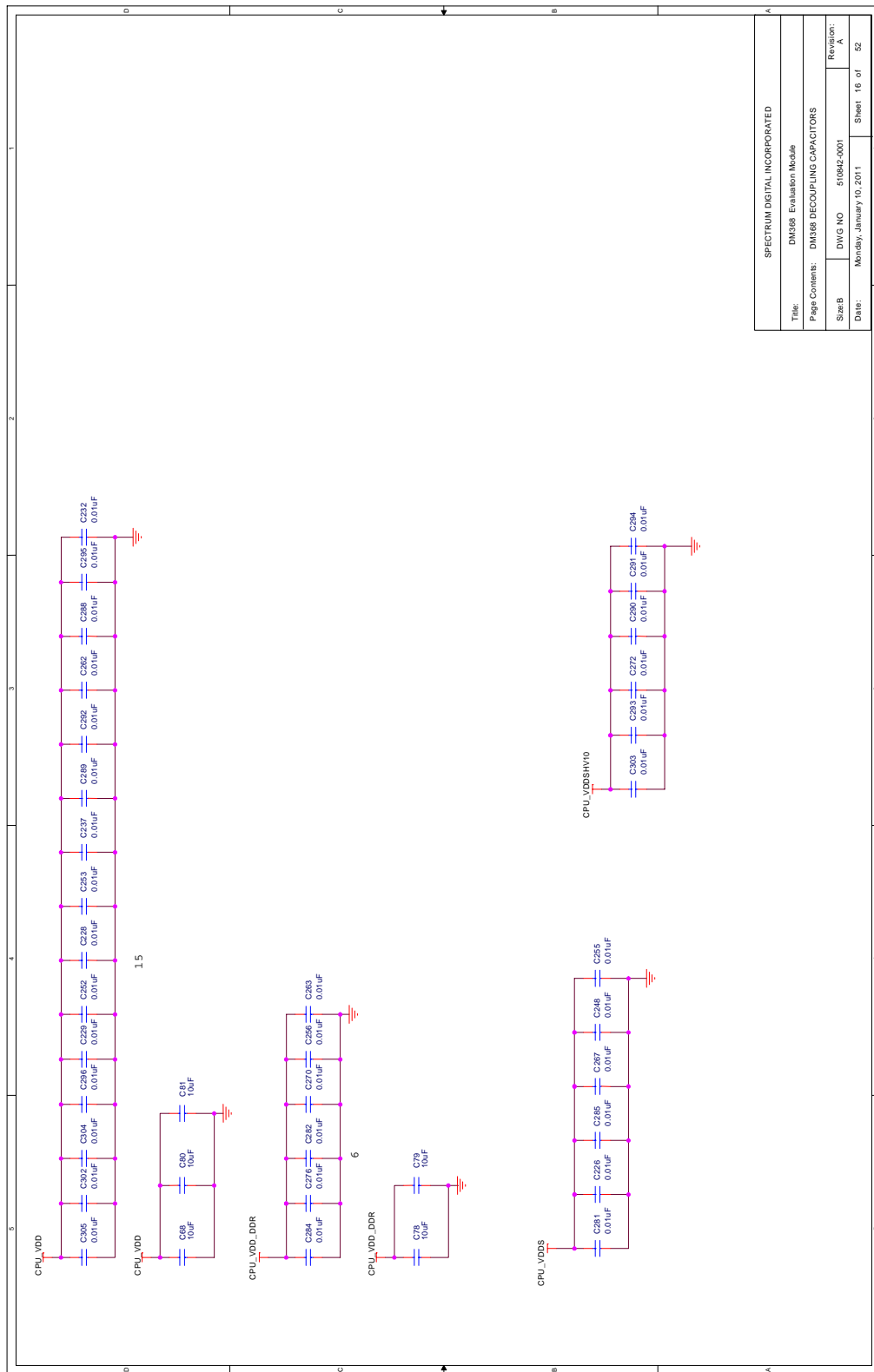

SPECTRUM DIGITAL INCORPORATED	
Title:	DM368 Evaluation Module
Page Contents:	DM368 DECOUPLING CAPACITORS
Sheet:	DM368-510842-0001
Date:	Monday, January 10, 2011
Revision:	A
Sheet	16 of 52

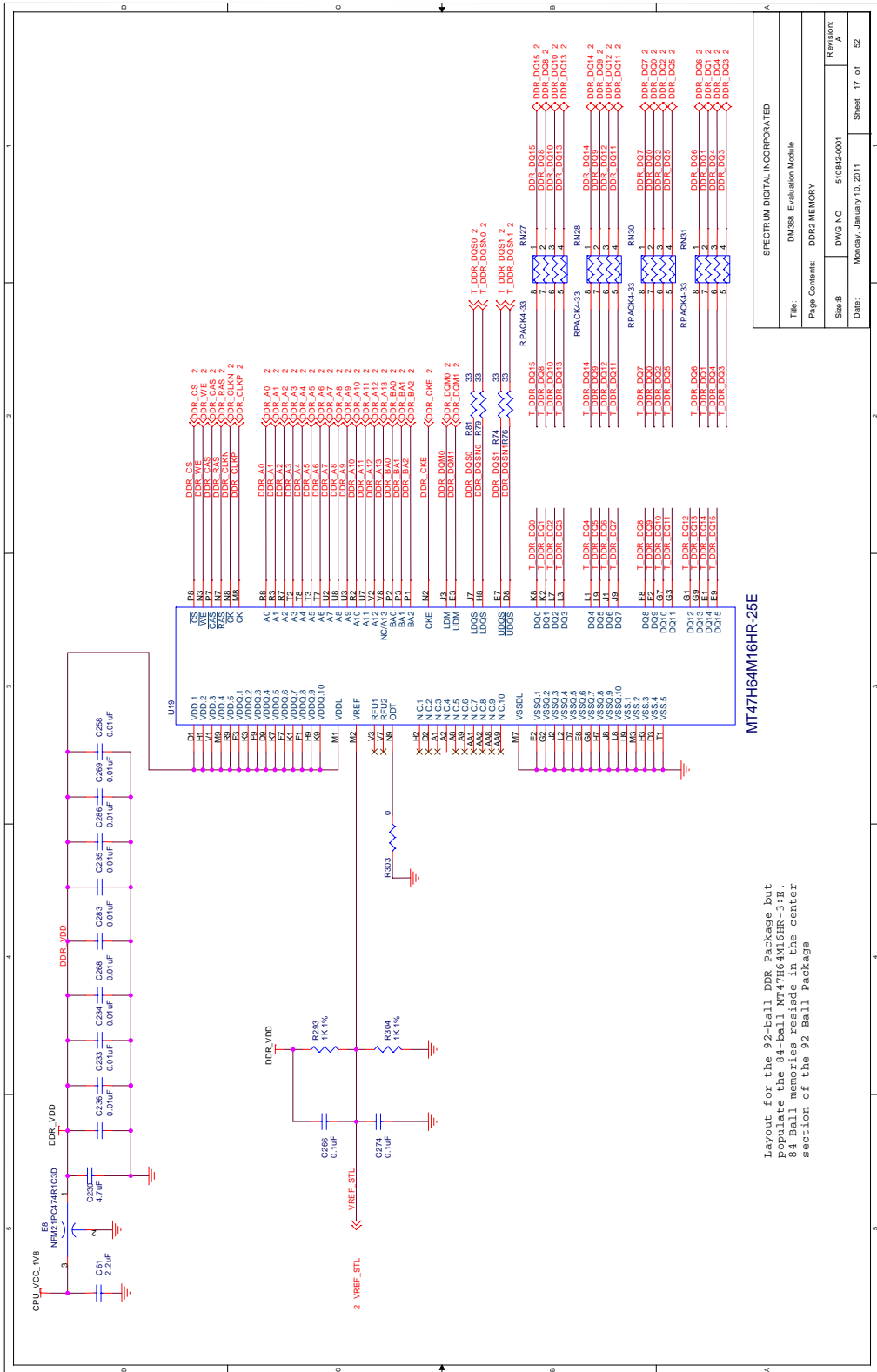

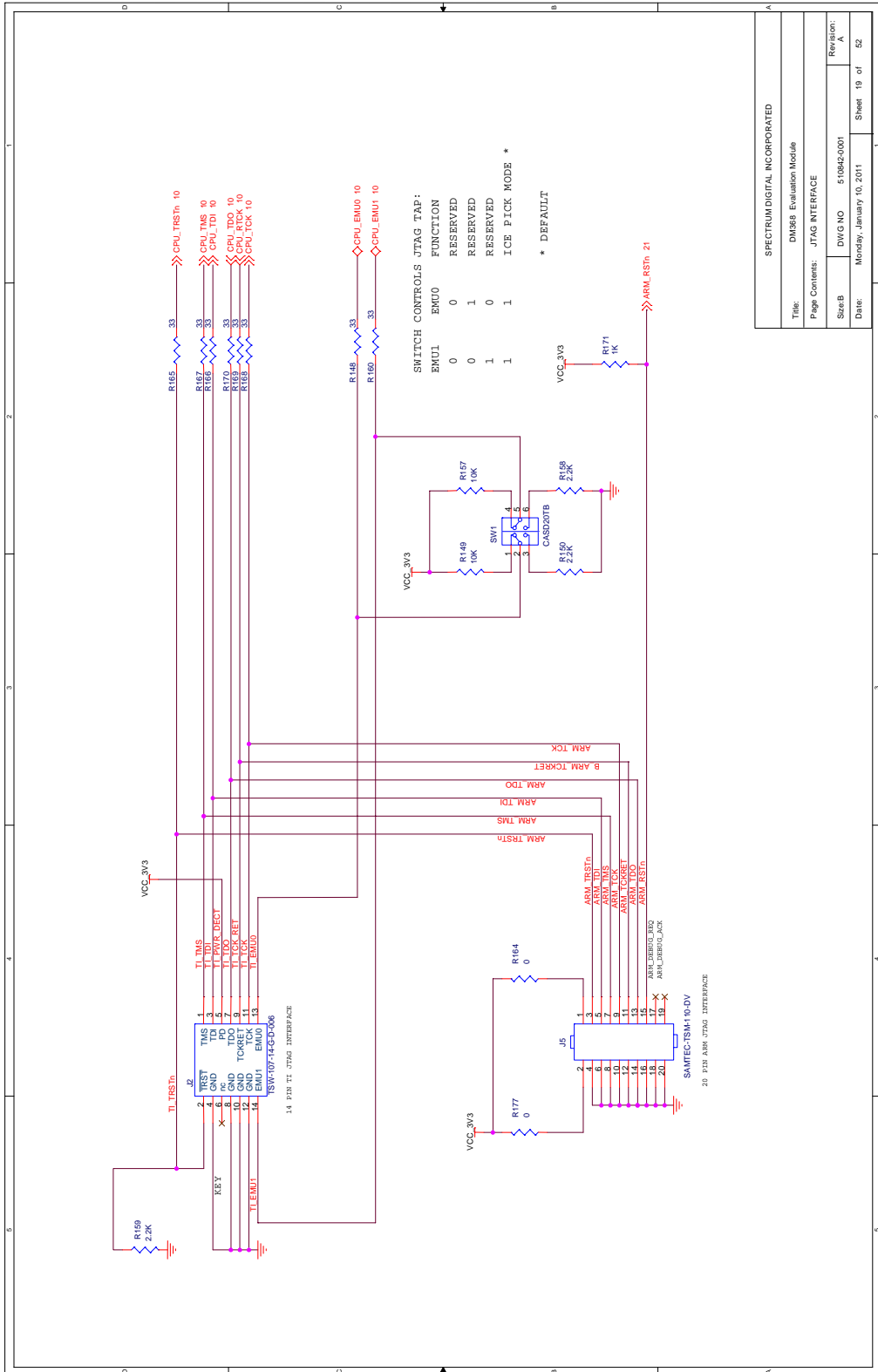

SPECTRUM DIGITAL INCORPORATED	
Title:	DM368 Evaluation Module
Page Contents:	JTAG INTERFACE
SizeB	DWG NO 510842-0001
Date:	Monday, January 10, 2011
Sheet	19 of 52

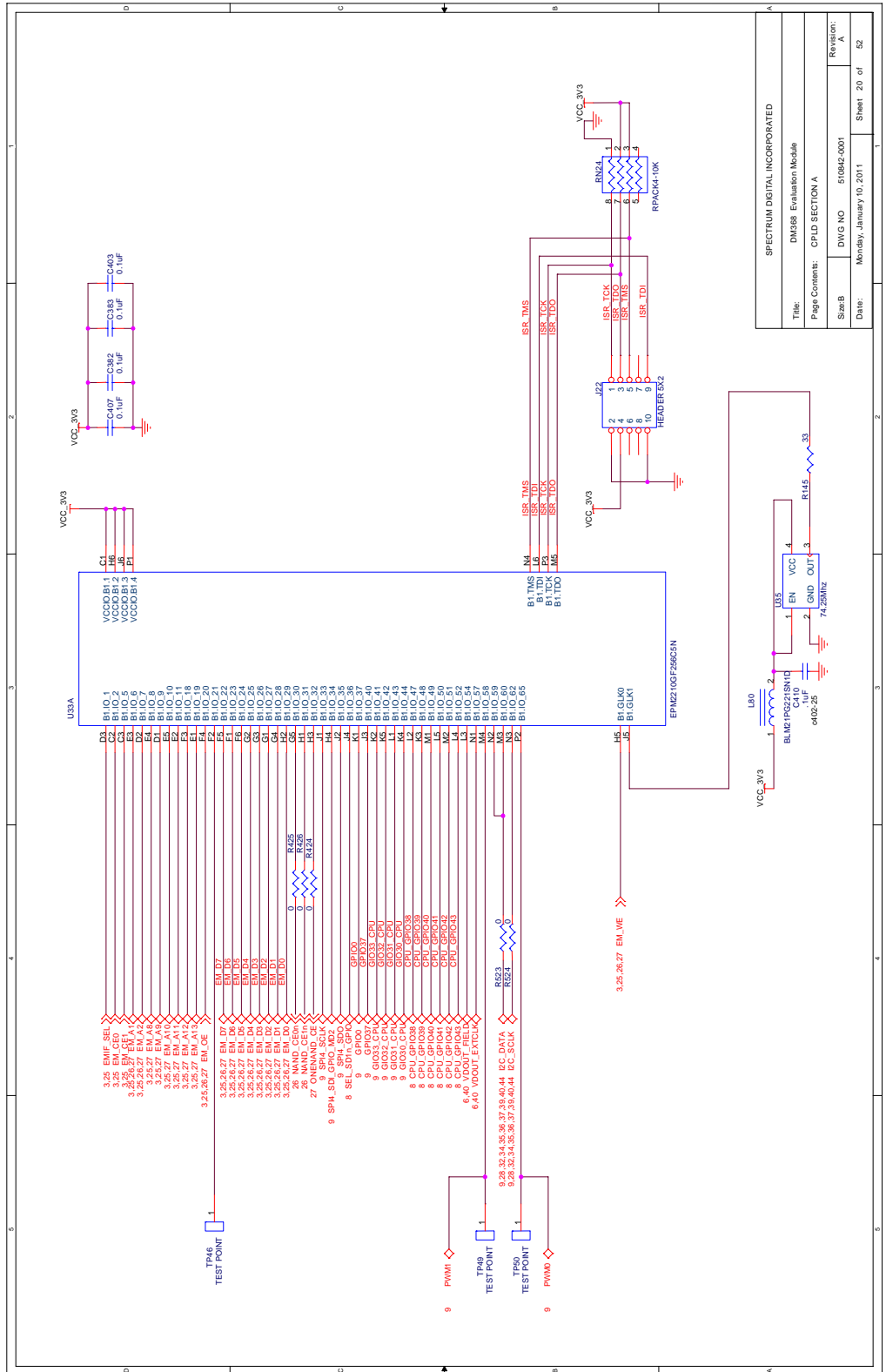

SPECTRUM DIGITAL INCORPORATED	
Title:	DA368 Evaluation Module
Page Contents:	CPLD SECTION A
Sheet:	DWG NO 510842.0001
Date:	Monday, January 10, 2011
Revision:	A
	Sheet 20 of 52

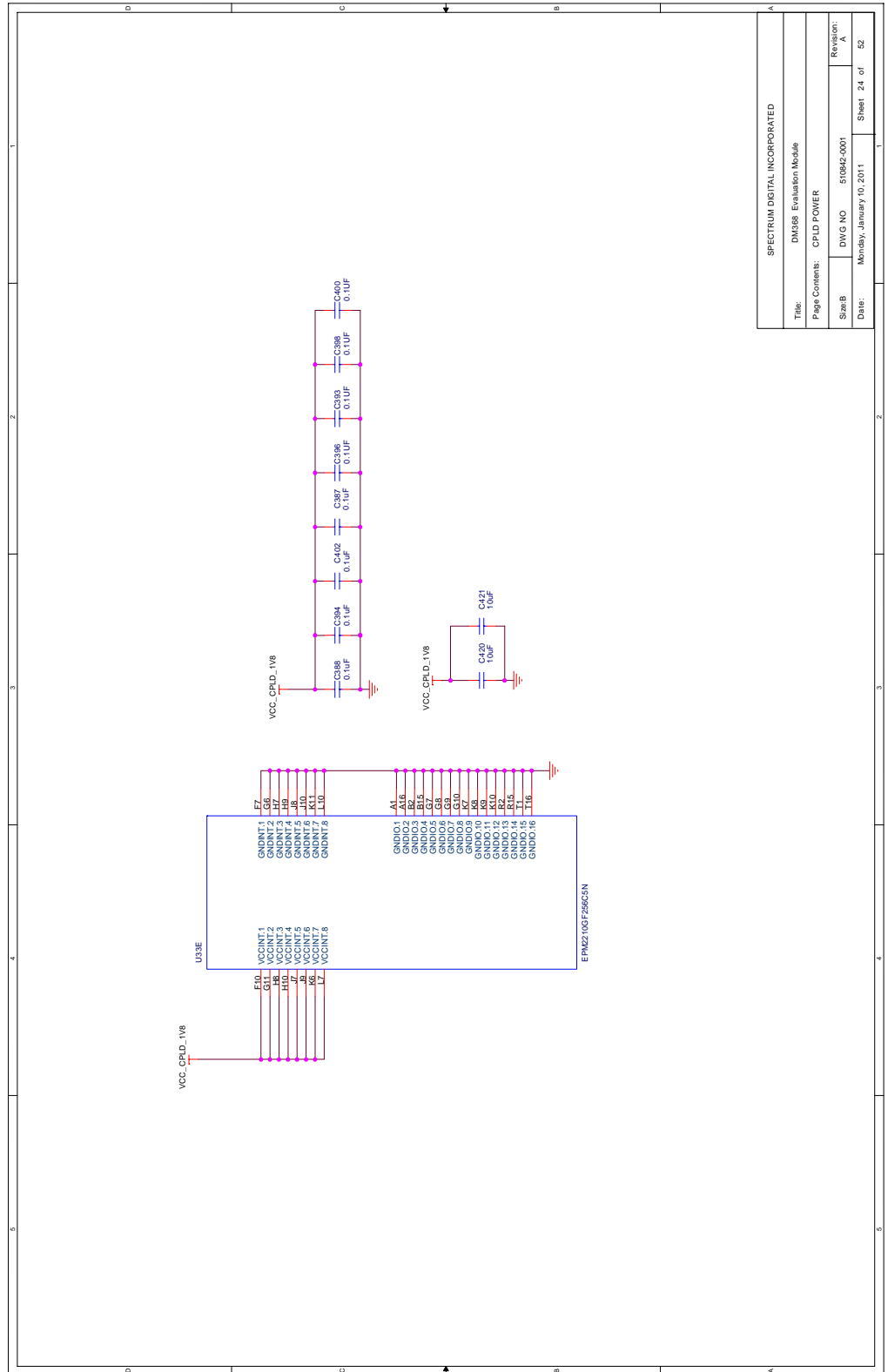

SPECTRUM DIGITAL INCORPORATED			
Title: DM388 Evaluation Module			
Page Contents: CPLD POWER			
Size: B	DWG NO: 510842-0001	Revision: A	
Date: Monday, January 10, 2011	Sheet: 24	of 52	

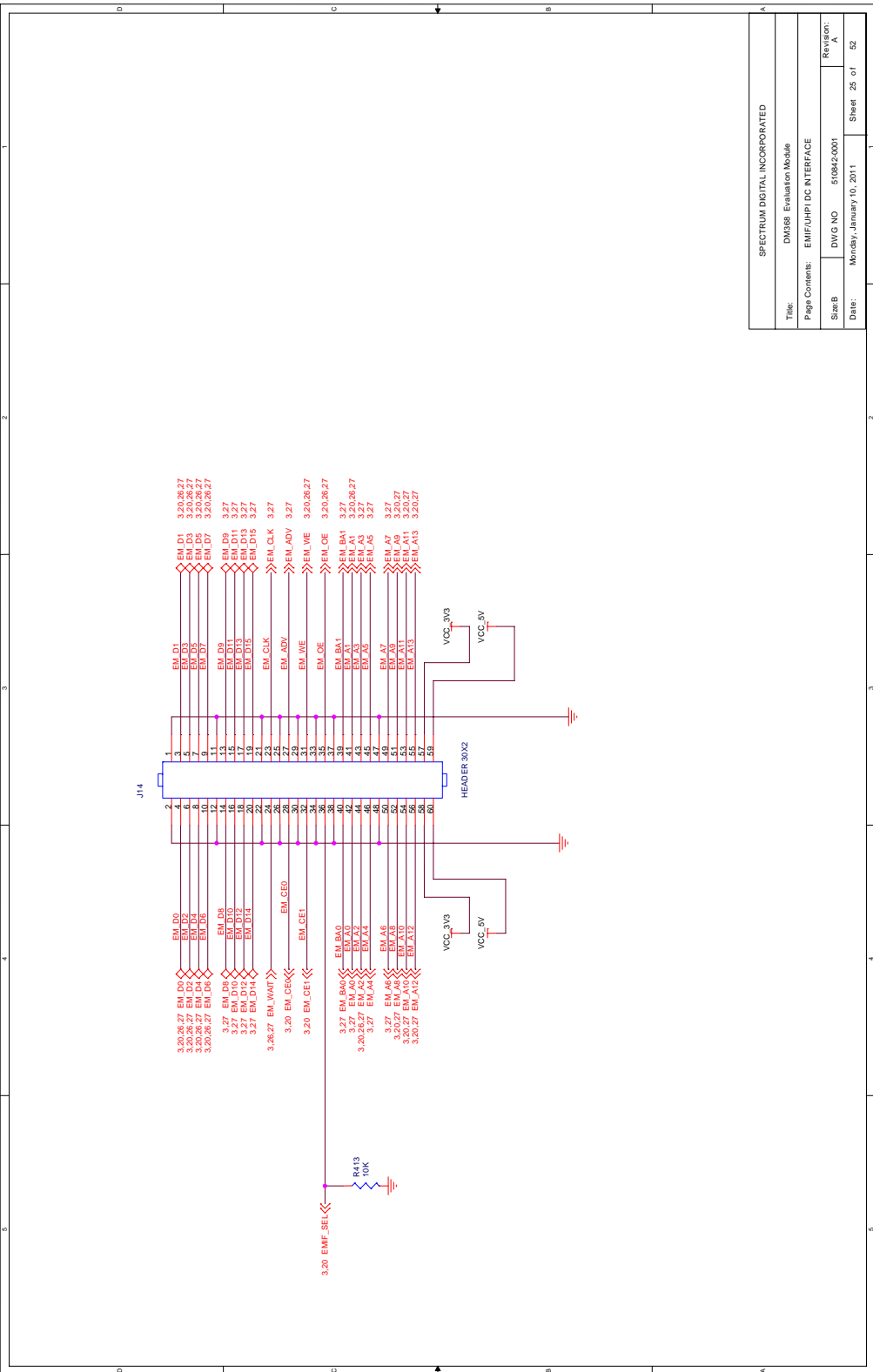

SPECTRUM DIGITAL INCORPORATED			
Title: DM368 Evaluation Module			
Page Contents: EMF/UHPI DC INTERFACE			
Size/B	DWG NO	Revision:	
	510842/001	A	
Date:	Monday, January 10, 2011	Sheet	25 of 52

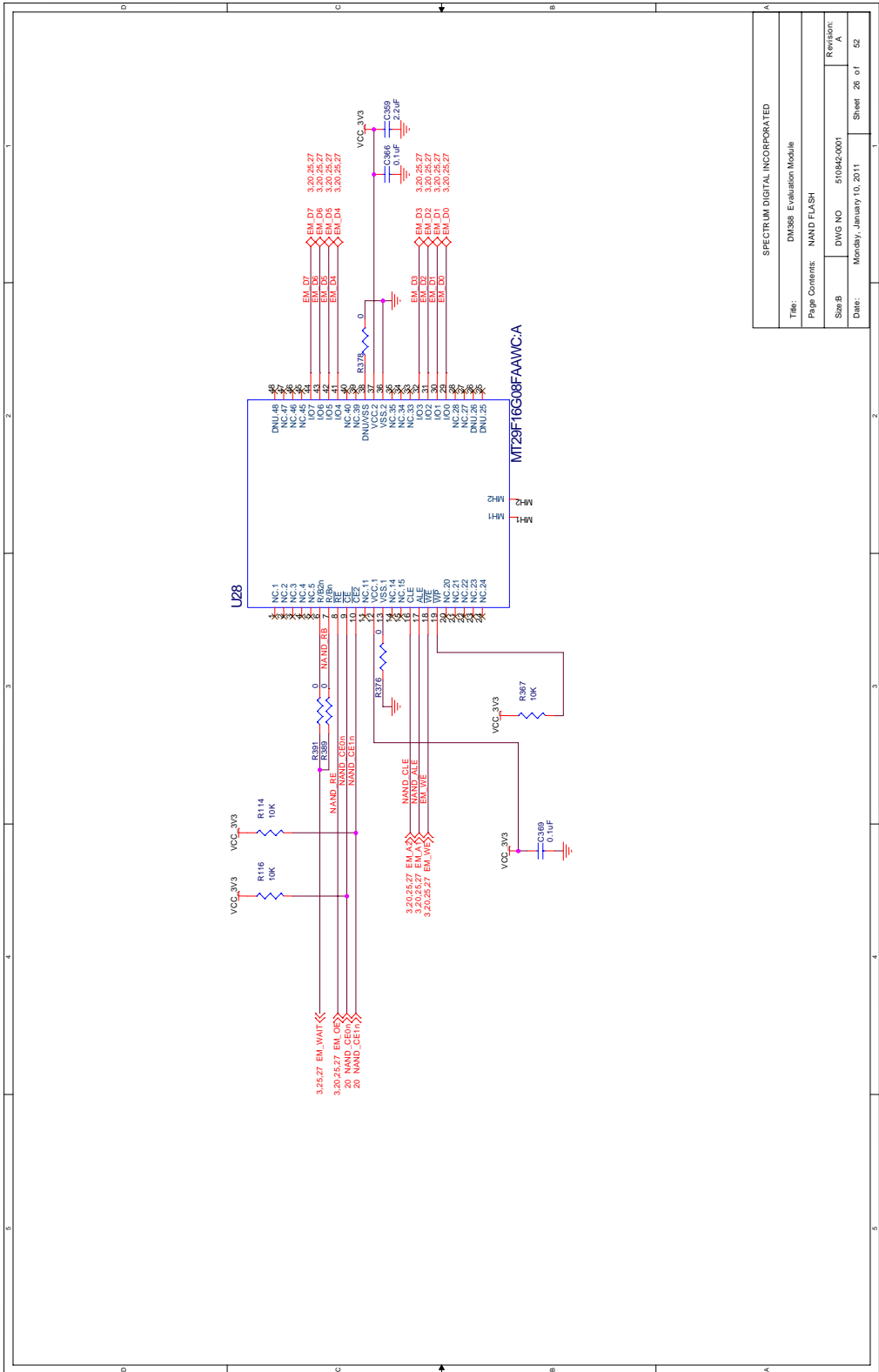

SPECTRUM DIGITAL INCORPORATED	
Title:	DM968 Evaluation Module
Page Contents:	NAND FLASH
Size: B	Revision: A
Date:	DWG NO 510842/001
	Monday, January 10, 2011
	Sheet 26 of 52

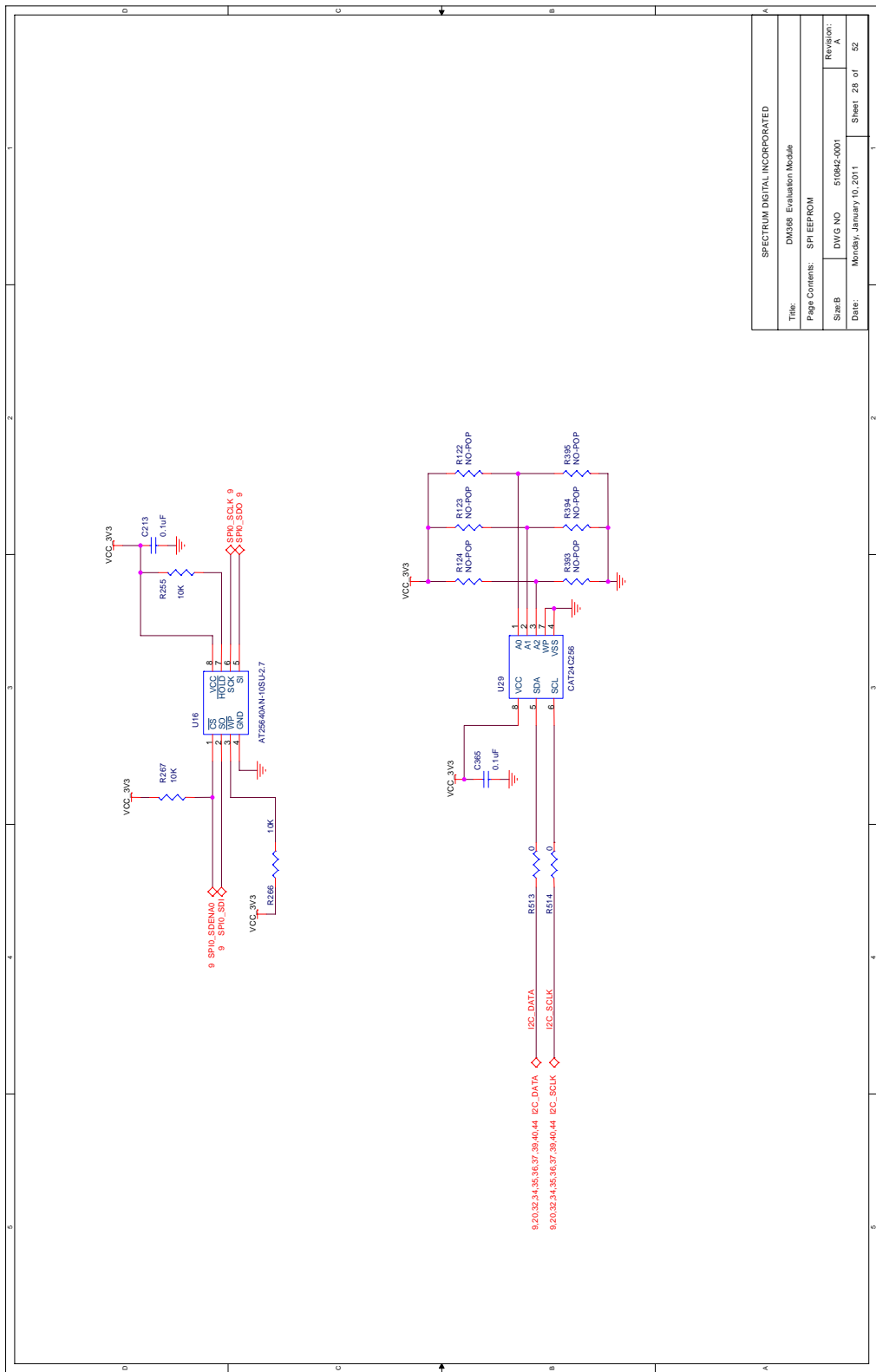

SPECTRUM DIGITAL INCORPORATED	
Title:	DM368 Evaluation Module
Page Contents:	SPI EEPROM
Sheet:	DWG NO 510842-0001
Date:	Monday, January 10, 2011
Revision:	A
Sheet:	28 of 52

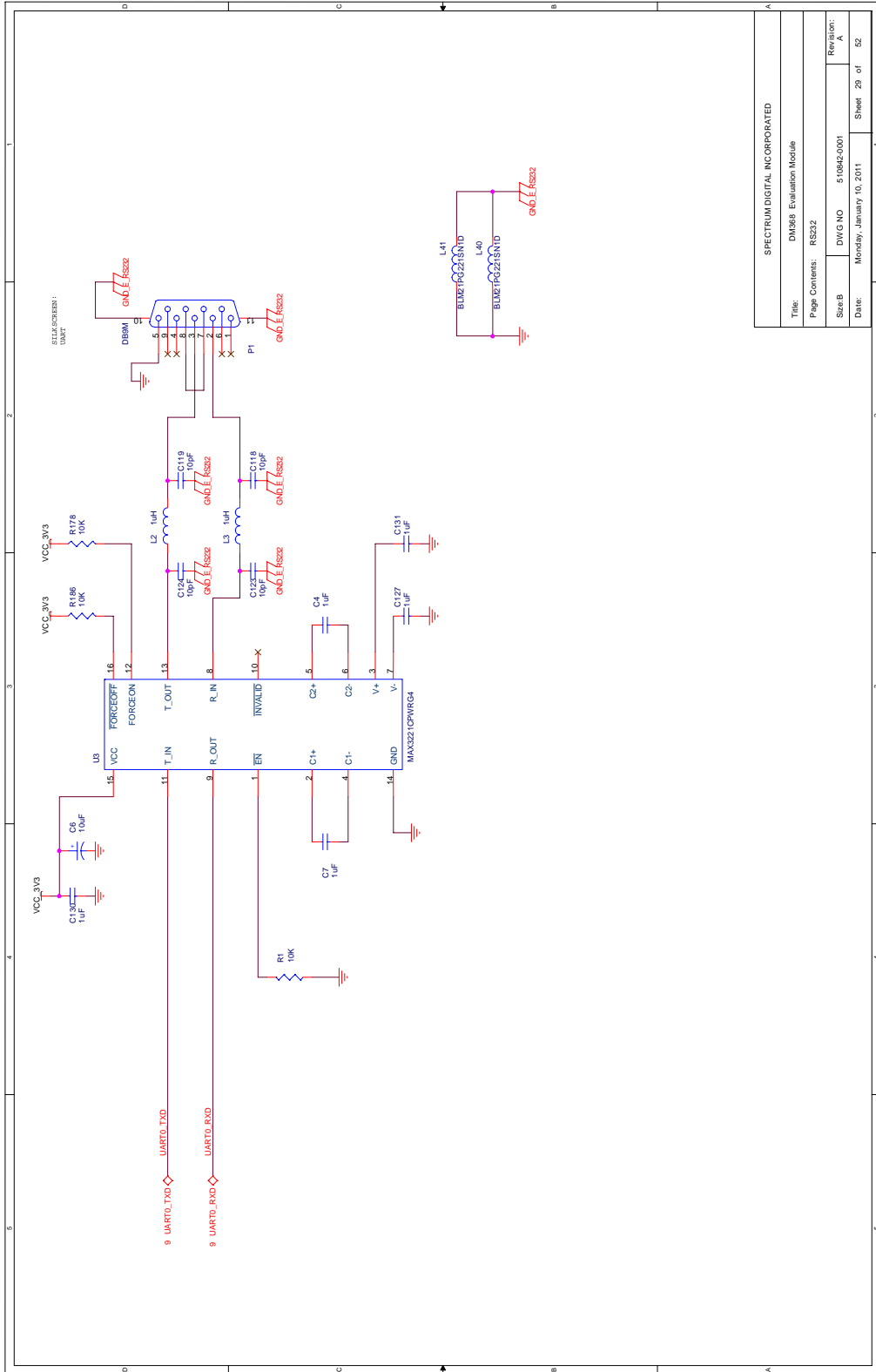

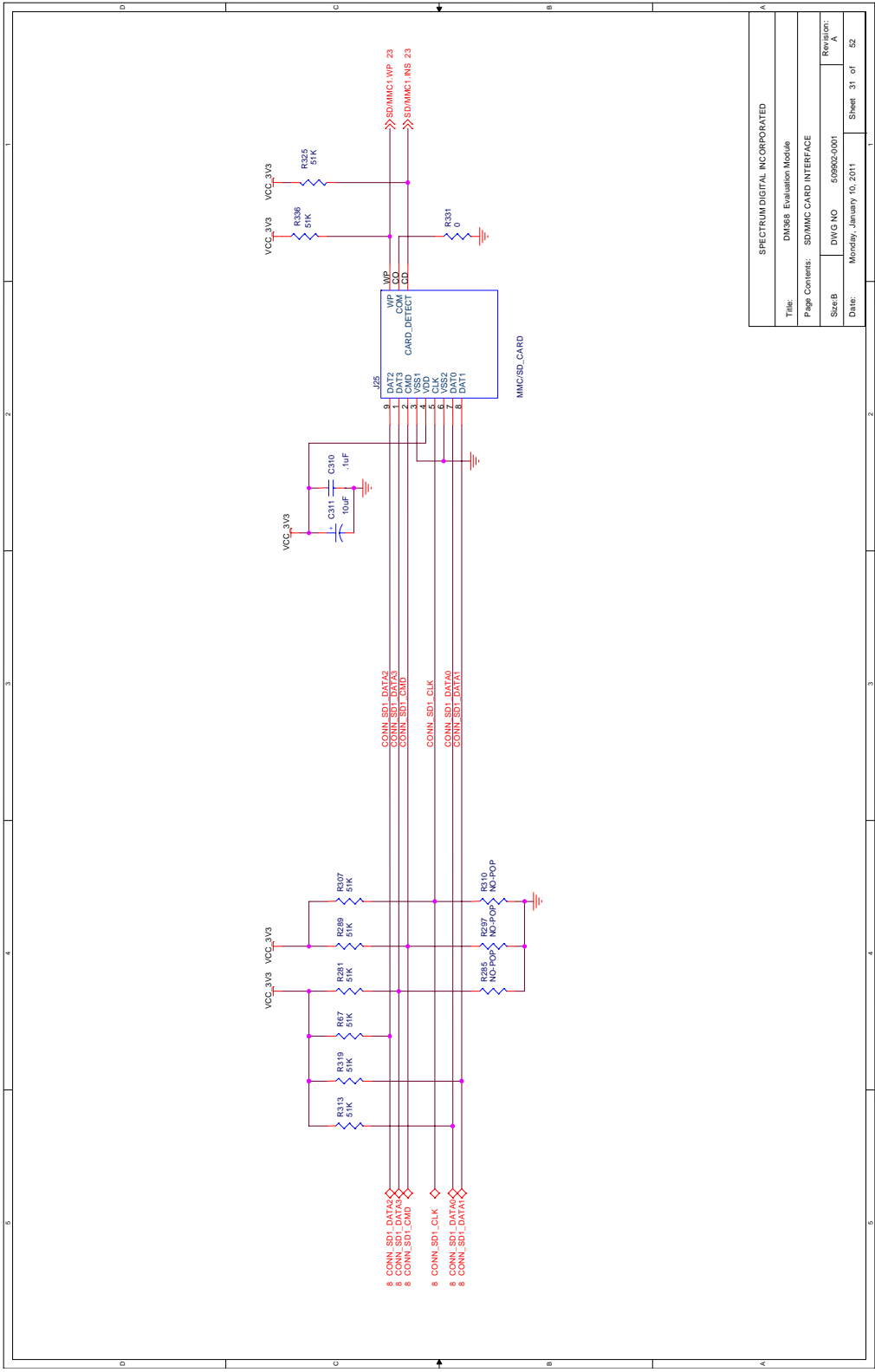

SPECTRUM DIGITAL INCORPORATED	
Title:	DM368 Evaluation Module
Page Contents:	SDMMC CARD INTERFACE
Sheet:	52
DWG NO:	509082-0001
Revision:	A
Date:	Monday, January 10, 2011
Sheet	31 of 52

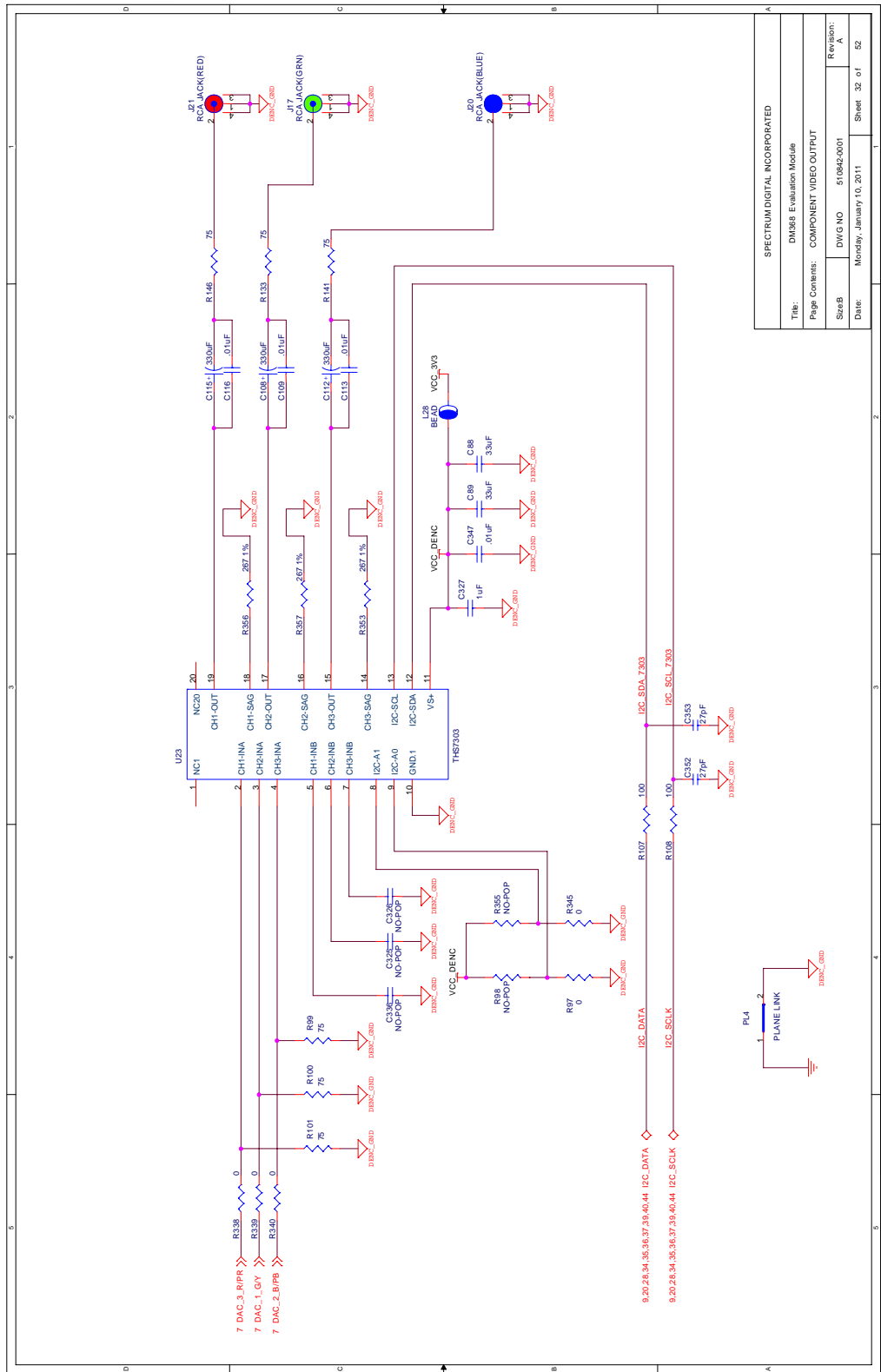

SPECTRUM DIGITAL INCORPORATED	
Title:	DM568 Evaluation Module
Page Contents:	COMPONENT VIDEO OUTPUT
Size: B	DWG NO 510842-0001
Date:	Monday, January 10, 2011
Revision:	A
Sheet	32 of 52

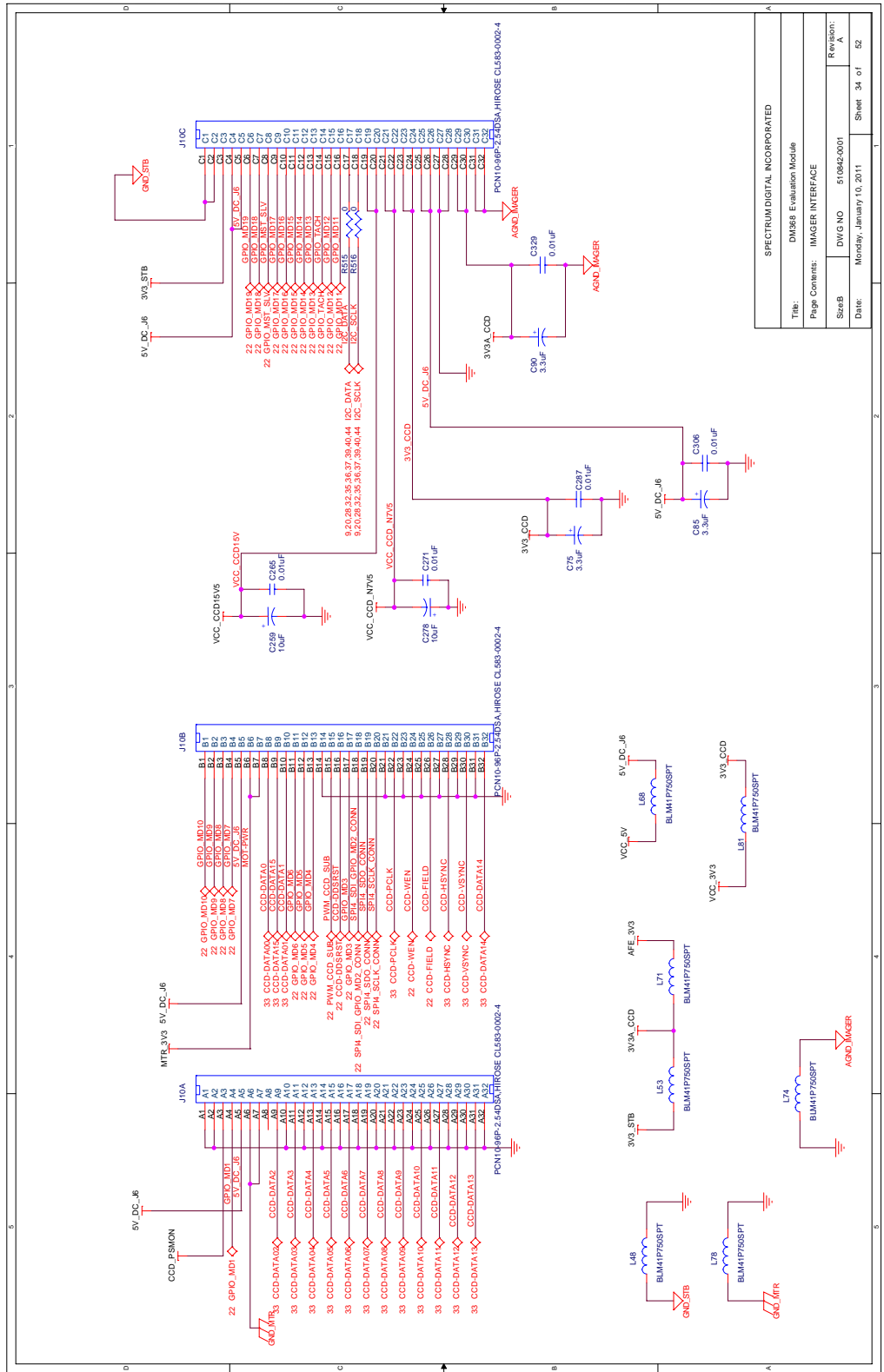

SPECTRUM DIGITAL INCORPORATED	
Title:	DM588 Emulation Module
Page Contents:	IMAGER INTERFACE
SizeB	DWGNO 510842-0001
Date:	Monday, January 10, 2011
Revision:	A
Sheet	34 of 52

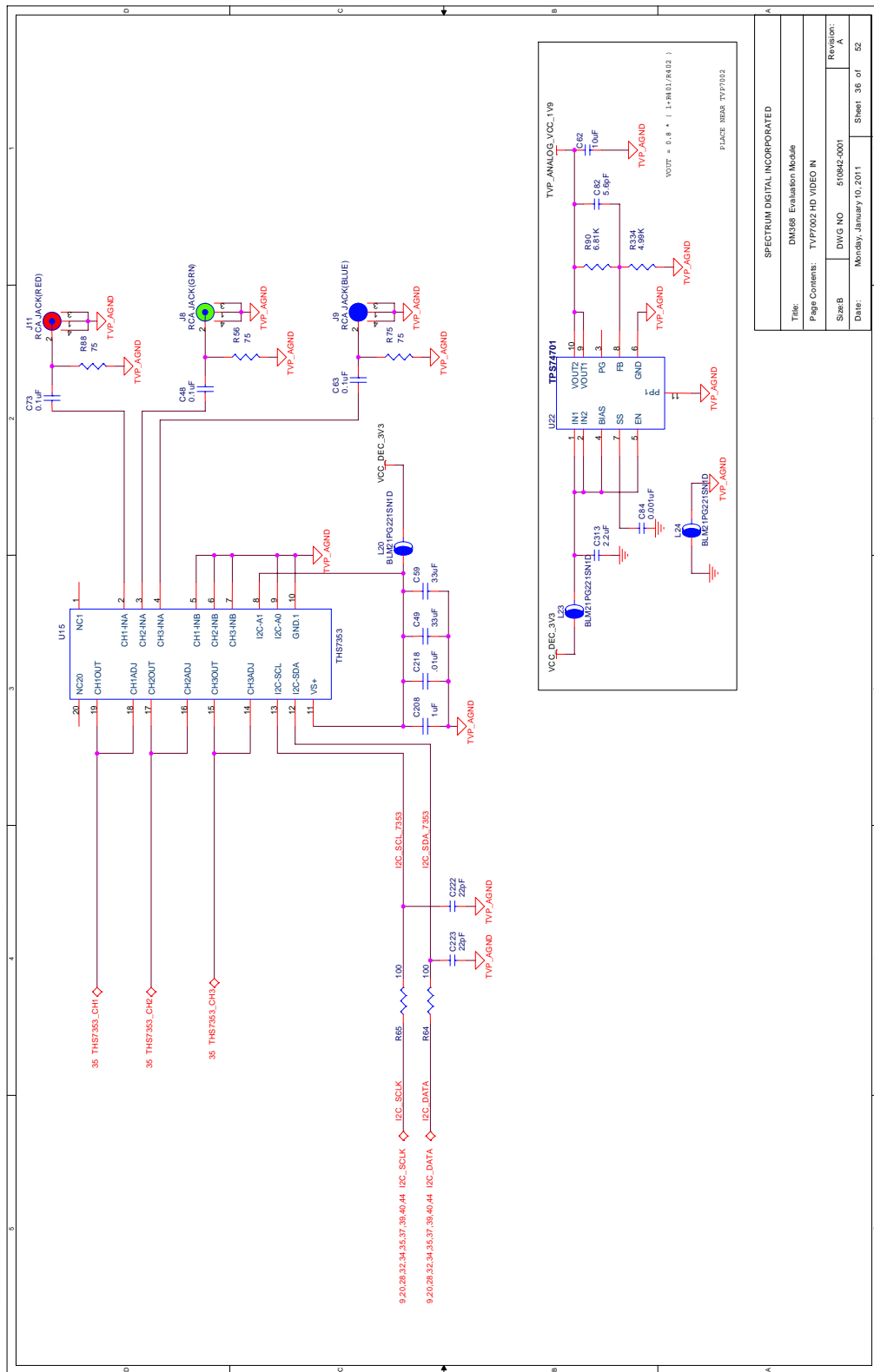

SPECTRUM DIGITAL INCORPORATED	
Title:	DM598 Evaluation Module
Page Contents:	TVP7002 HD VIDEO IN
Sheet:	Revision:
B	A
Date:	Sheet 36 of 52
Monday, January 10, 2011	5:08:42-0001

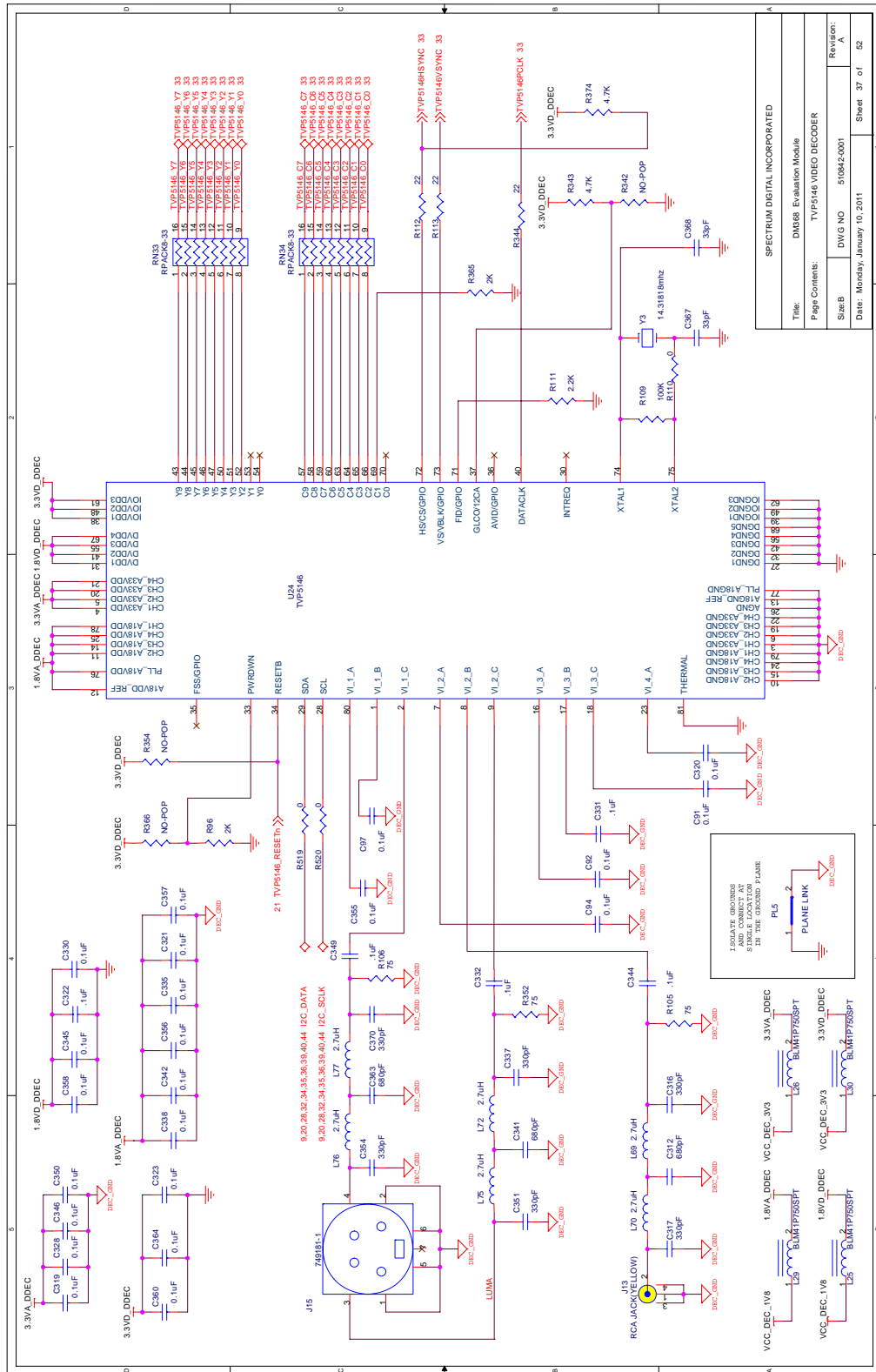

SPECTRUM DIGITAL INCORPORATED	
Title:	DM368 Evaluation Module
Page Contents:	TYP5146 VIDEO DECODER
Size:	DWG NO. 510842-001
Date:	Monday, January 10, 2011
Revision:	A
Sheet	37 of 52

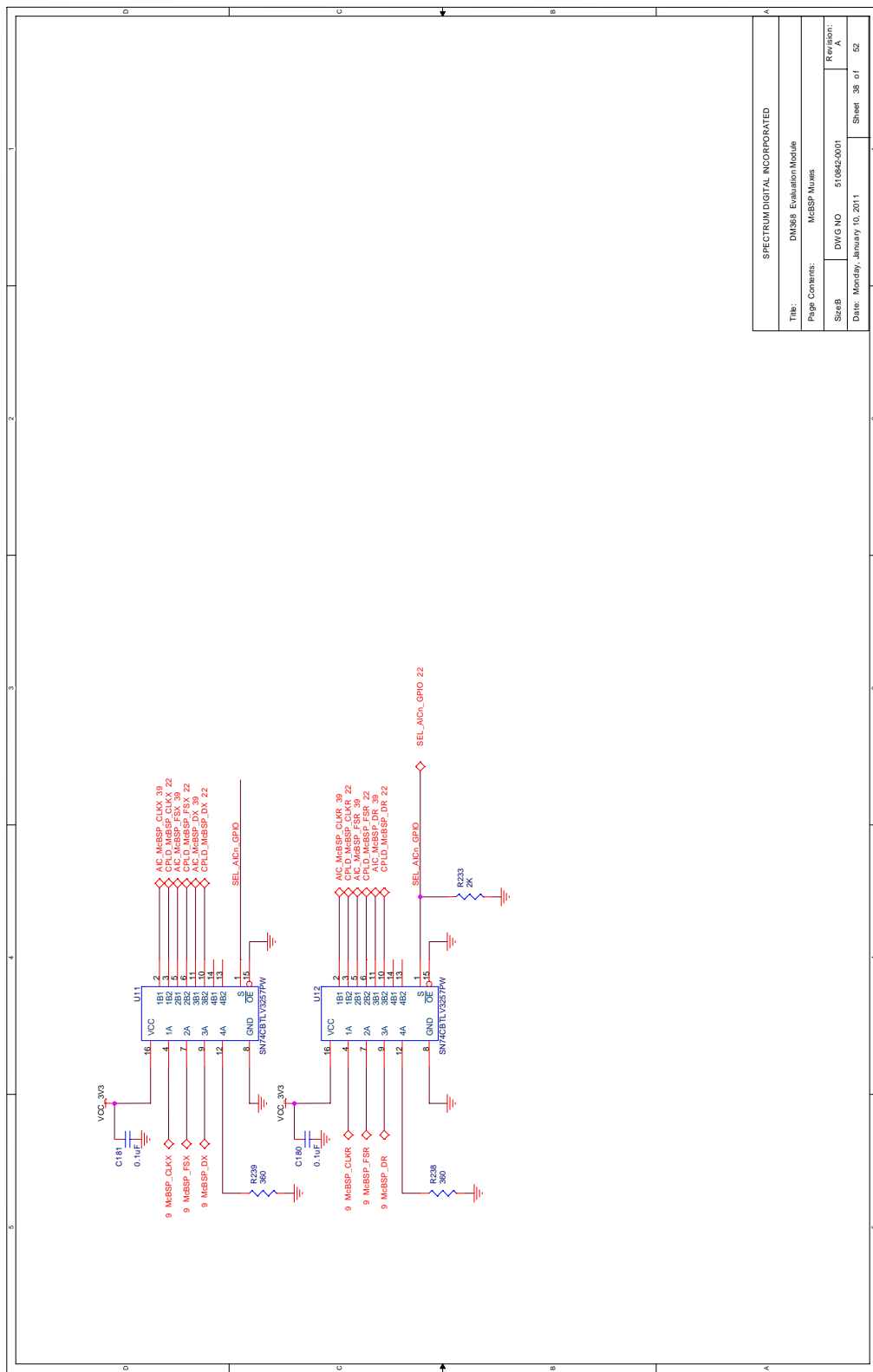

SPECTRUM DIGITAL INCORPORATED	
Title:	DM388 Evaluation Module
Page Contents:	McBSP Muxes
SizeB:	DWGNO 510622001
Date:	Monday, January 10, 2011
Revision:	A
Sheet:	38 of 52

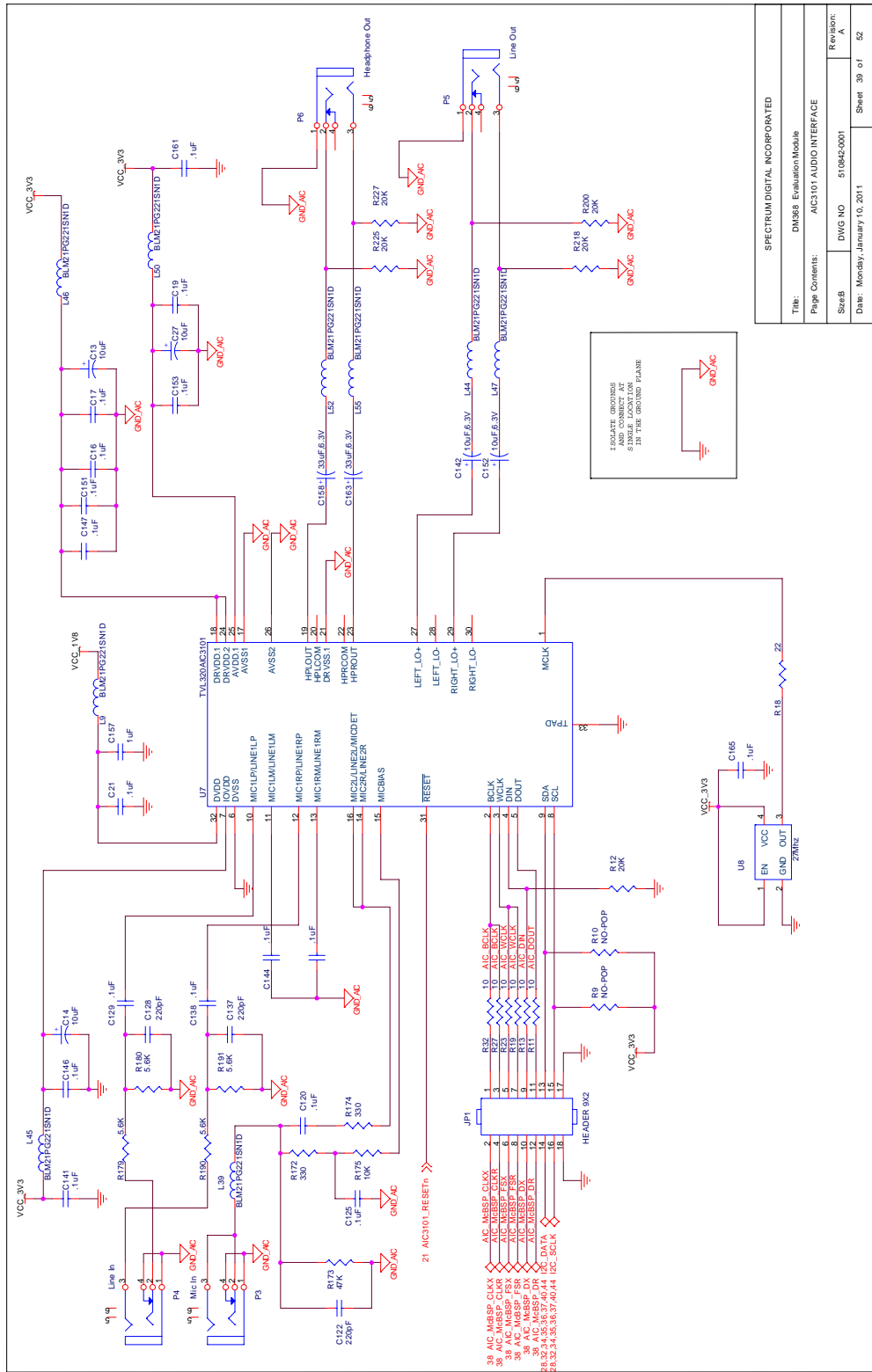

SPECTRUM DIGITAL INCORPORATED	
Title:	DM368 Evaluation Module
Page Contents:	AC13101 AUDIO INTERFACE
SizeB:	DWG NO 519842-0001
Date:	Monday, January 10, 2011
Revision:	A
Sheet	39 of 52

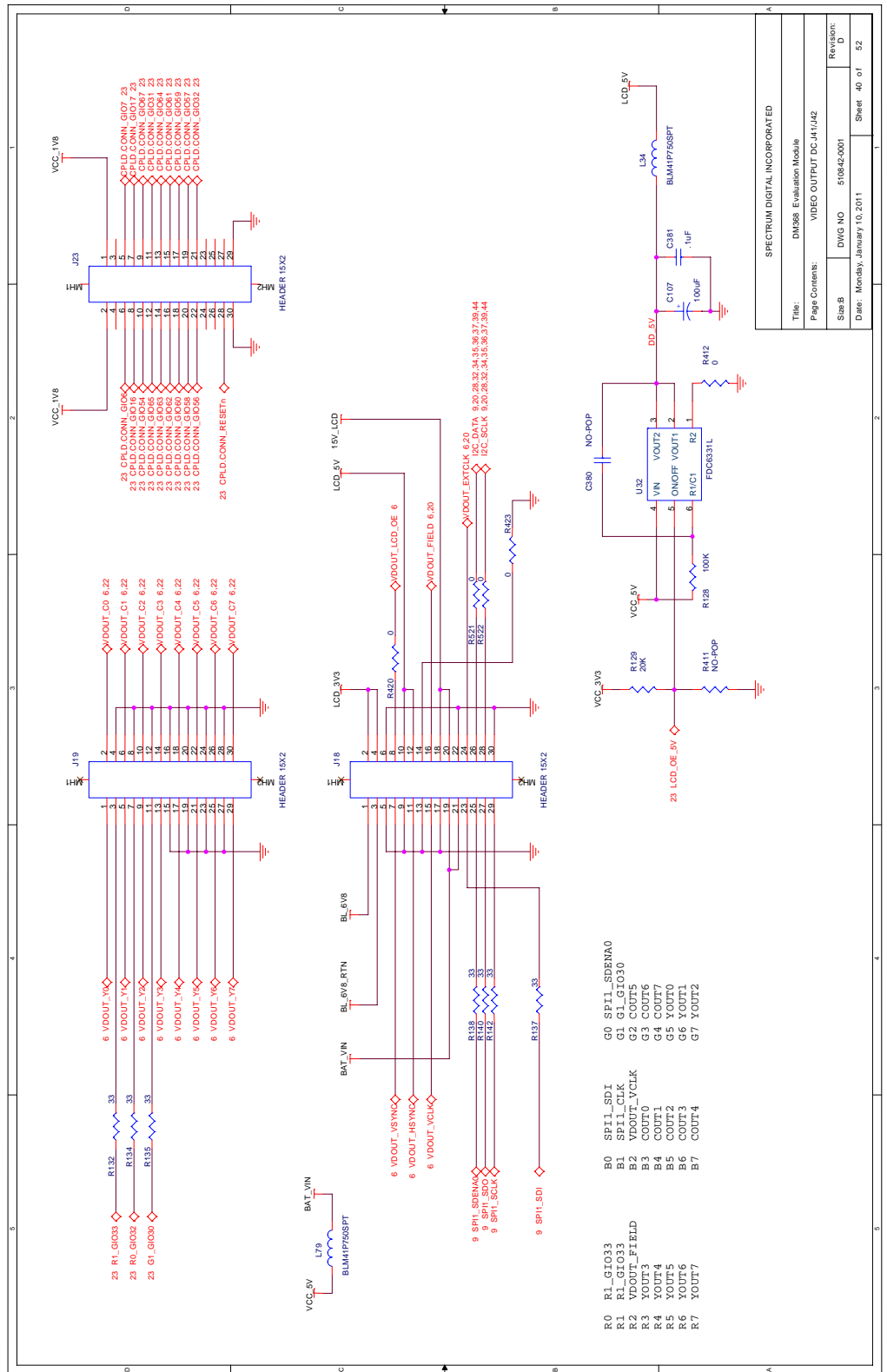

SPECTRUM DIGITAL INCORPORATED	
Title:	DM368 Evaluation Modul
Page Contents:	VIDEO OUTPUT DC-J1/J2
Sheet:	40 of 52
DWG NO:	51062-0001
Revision:	D
Date:	Monday, January 10, 2011

SPECTRUM DIGITAL INCORPORATED	
Title: DM368 Evaluation Module	
Page Contents: DLIC HOST CONNECTOR	
Size: B	DWG NO: 51084C-0001
Date: Monday, January 10, 2011	Revision: A
	Sheet 41 of 52

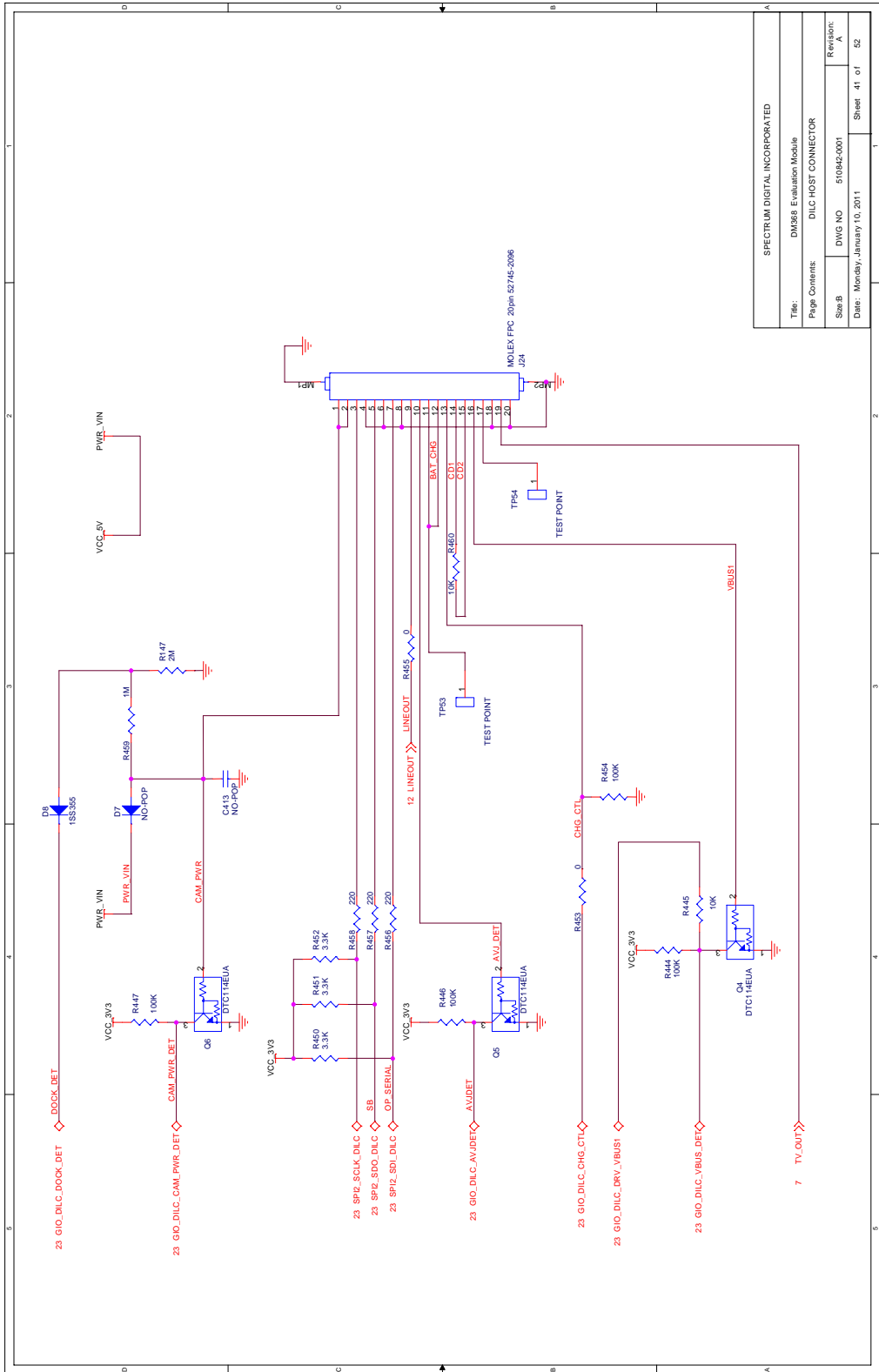

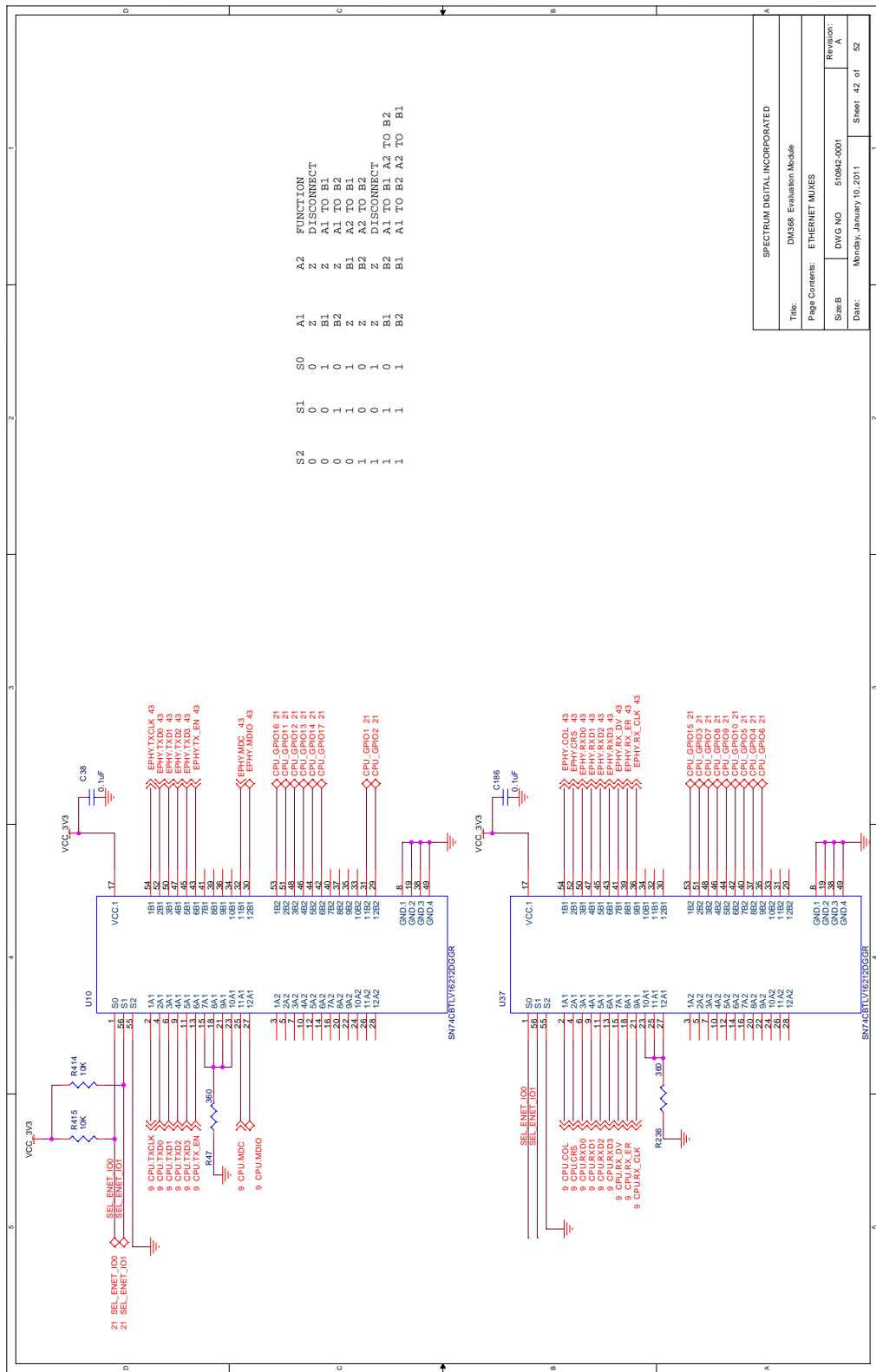

Title:		DM388 Evaluation Module	
Page Contents:		ETHERNET MIXES	
Size:	B	DWG NO	510842-001
Date:	Monday, January 10, 2011	Revision:	A
		Sheet	42 of 52

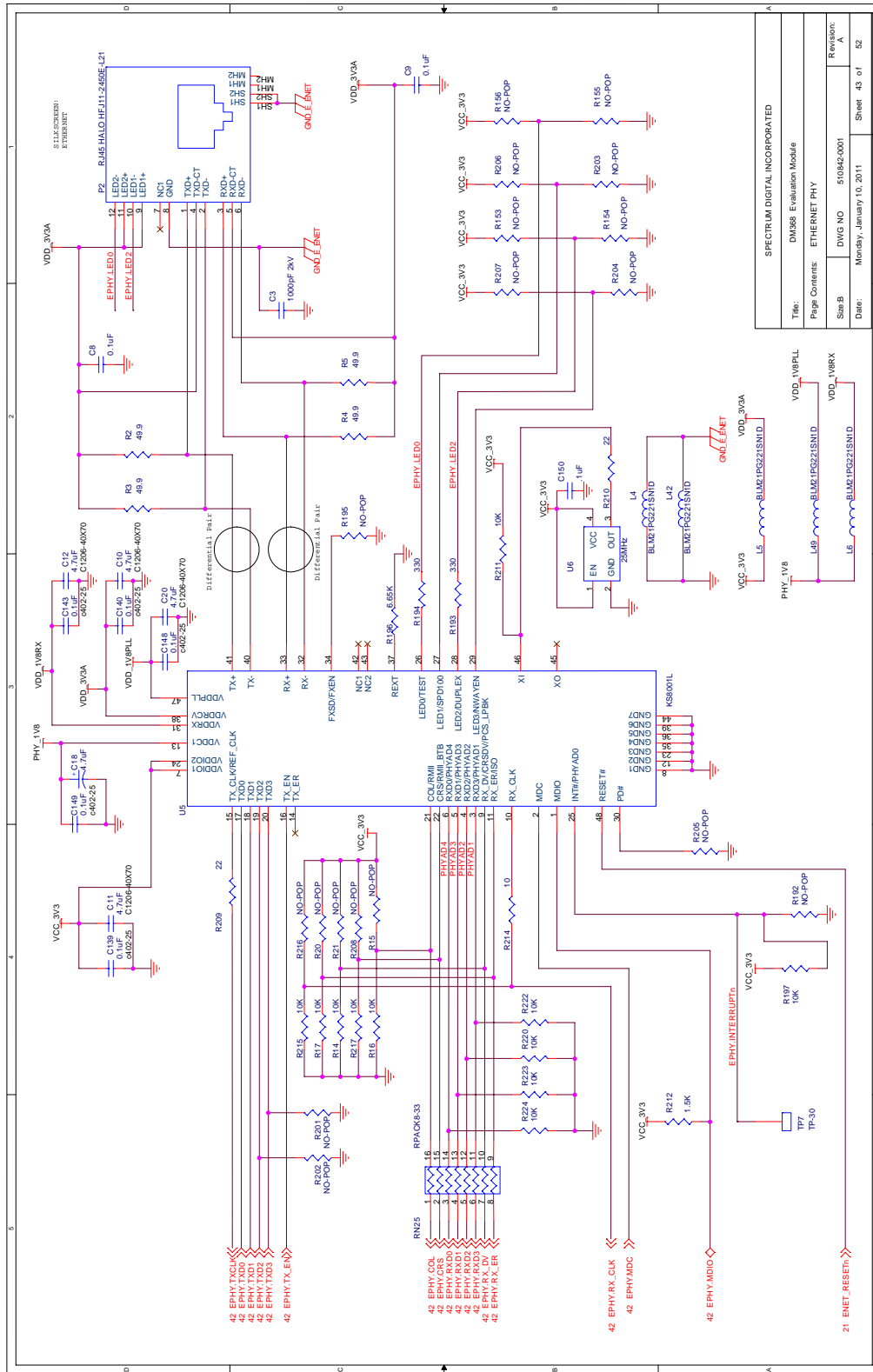

SPECTRUM DIGITAL INCORPORATED	
Title:	DM368 Evaluation Module
Page Contents:	ETHERNET PHY
Size B	DWG NO 510662-0001
Date:	Monday, January 10, 2011
Sheet	43 of 52

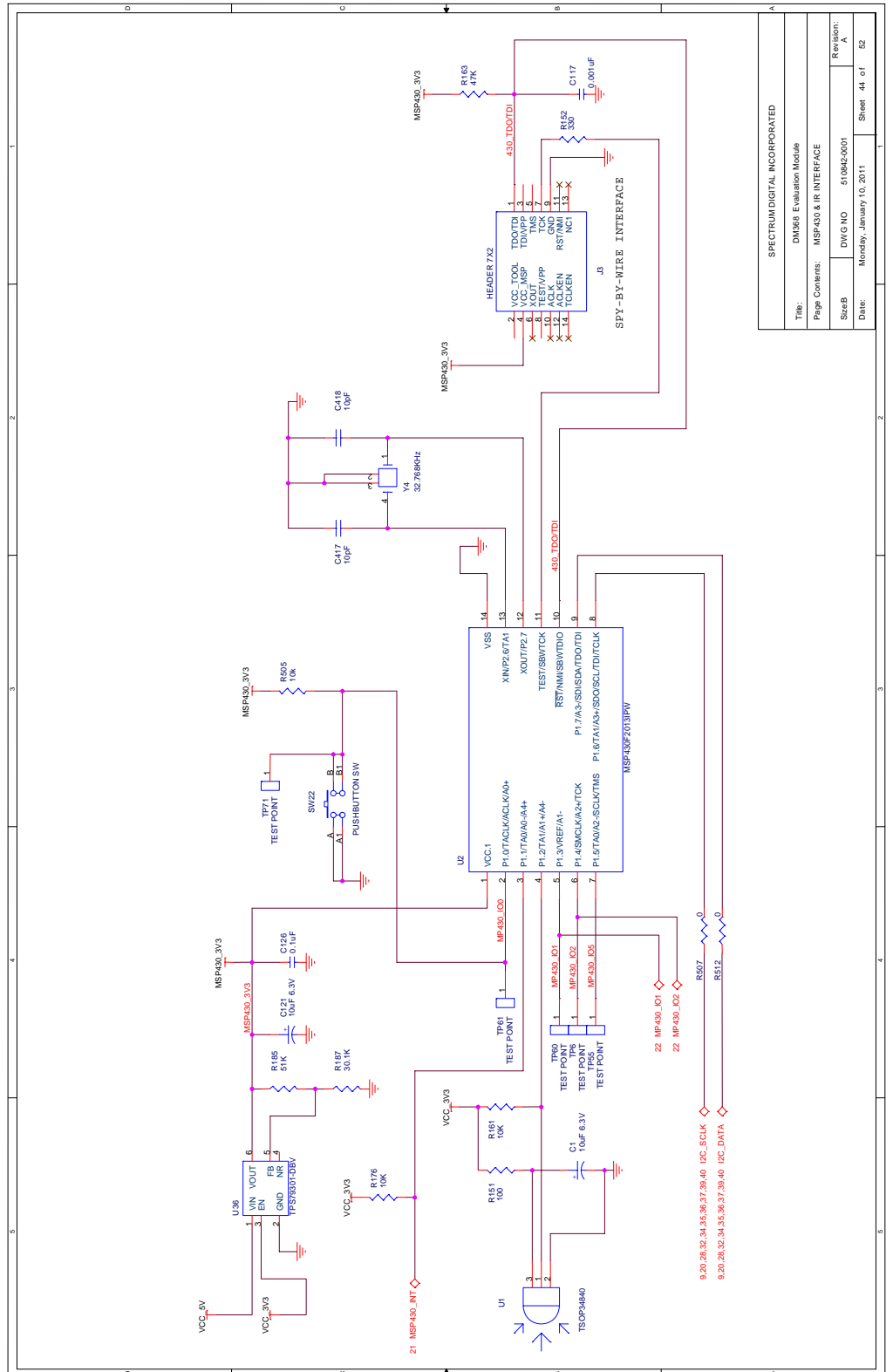

SPECTRUM DIGITAL INCORPORATED	
Title:	DM388 Evaluation Module
Page Contents:	MSP430 & IR INTERFACE
Size: B	DWG NO 510842-0001
Date:	Monday, January 10, 2011
Reason:	A
Sheet:	44 of 52

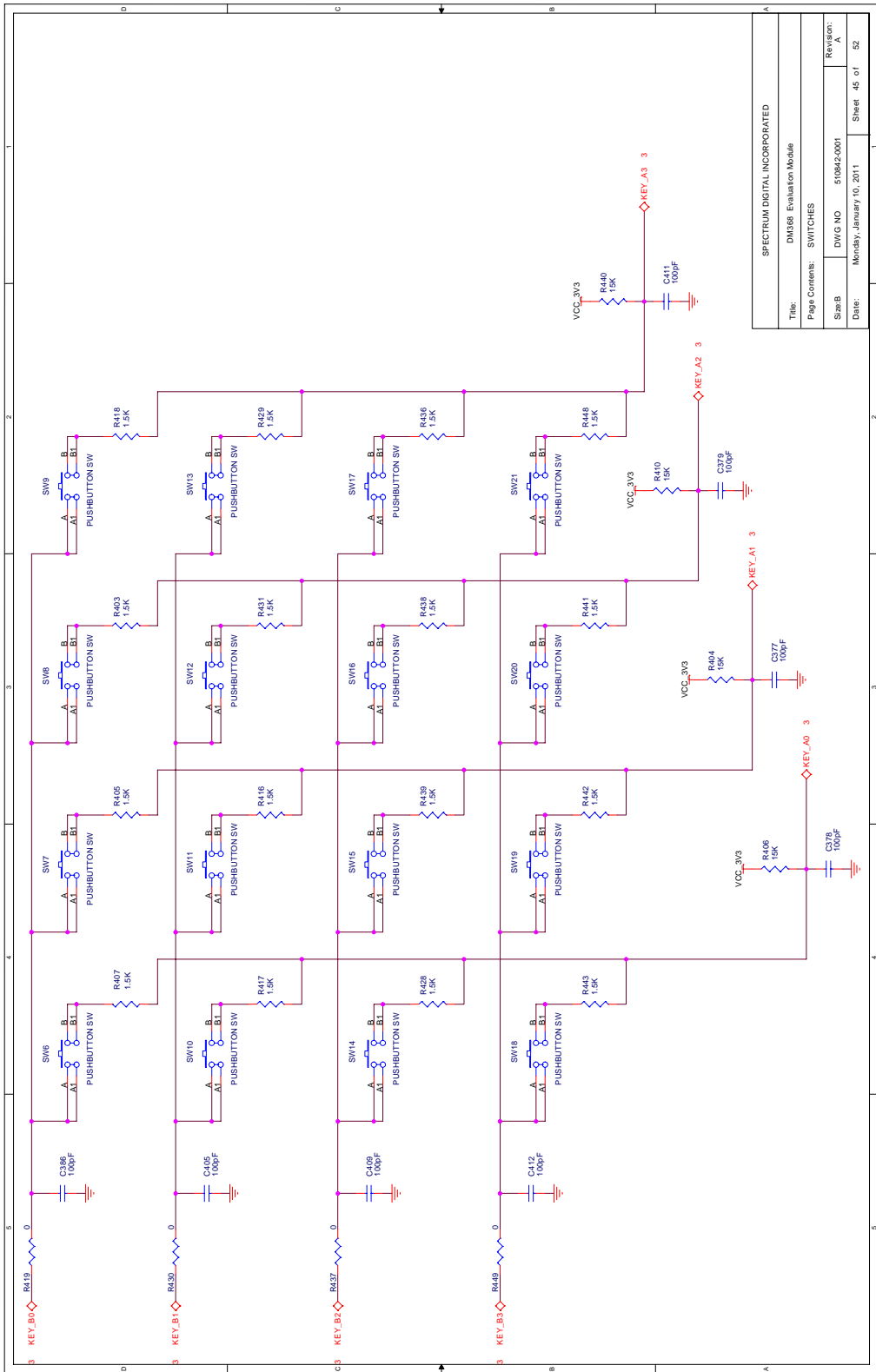

SPECTRUM DIGITAL INCORPORATED			
Title: DM368 Evaluation Module			
Page Contents: SWITCHES			
Size: B	DWG NO: 510842.0001	Revision: A	
Date: Monday, January 10, 2011		Sheet: 46 of 52	

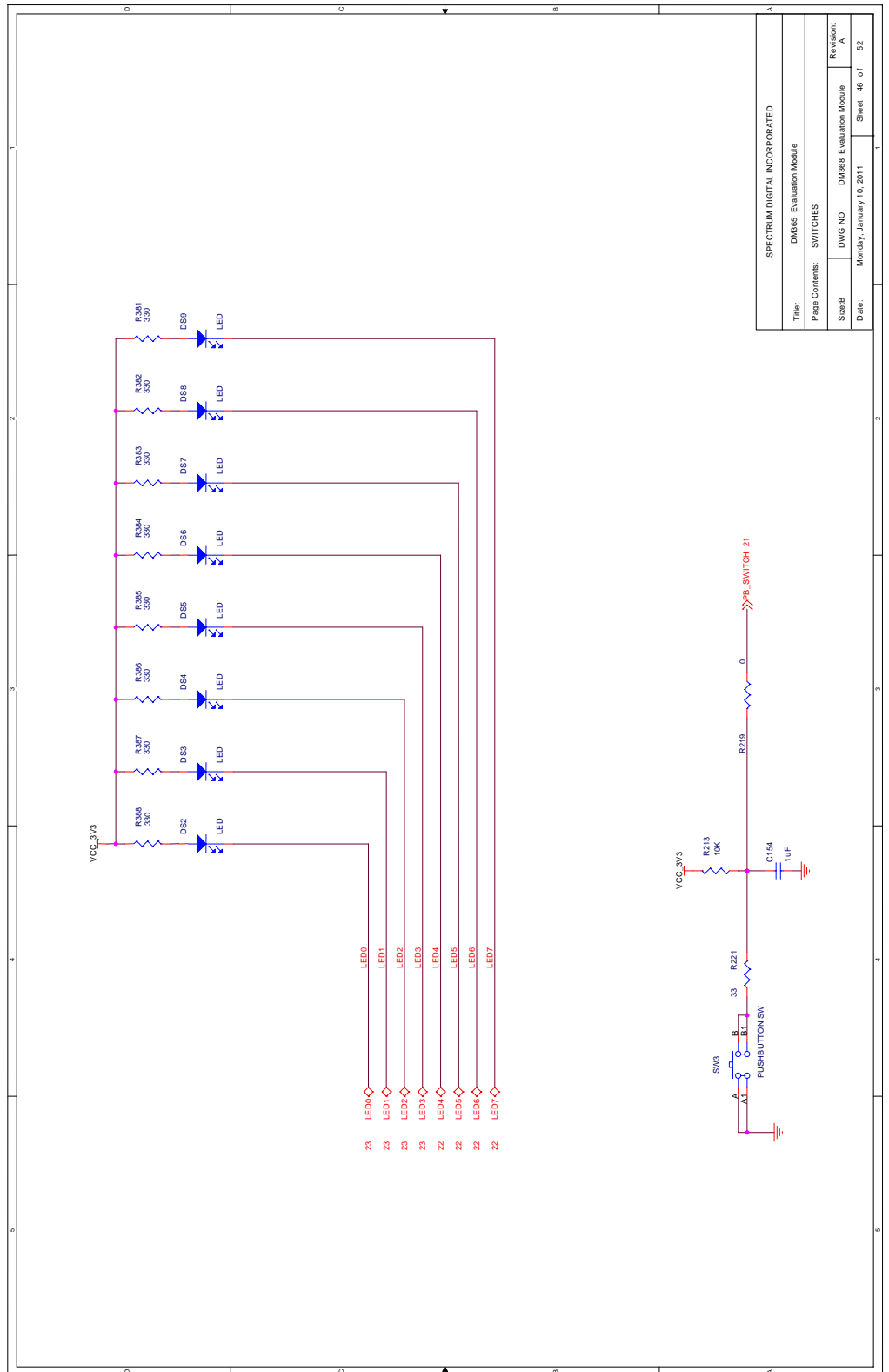

SPECTRUM DIGITAL INCORPORATED	
Title:	DM366 Evaluation Module
Page Contents:	SWITCHES
Size B:	DWG NO DM366 Evaluation Module
Date:	Monday, January 10, 2011
Revision:	A
Sheet	46 of 52

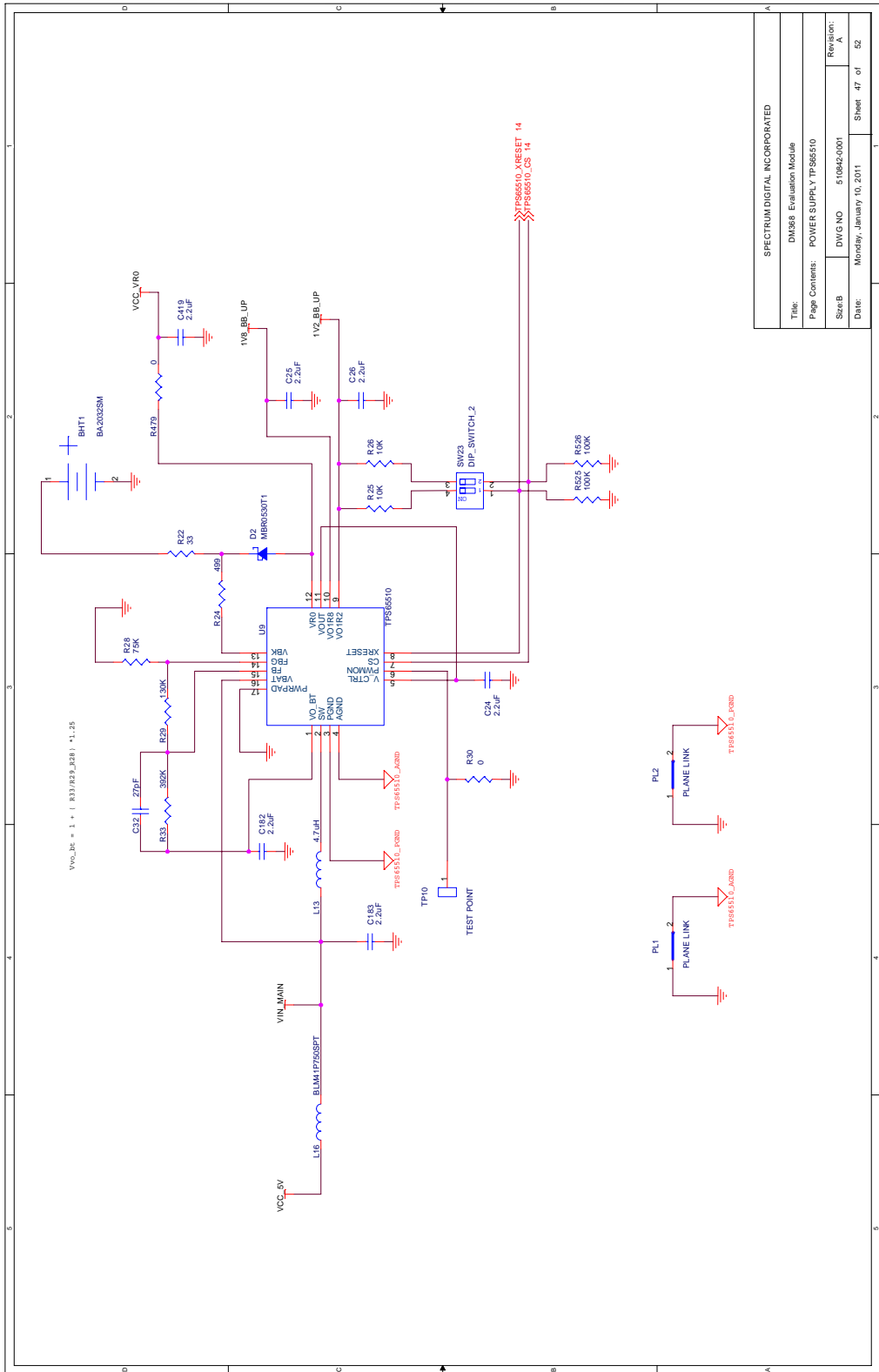

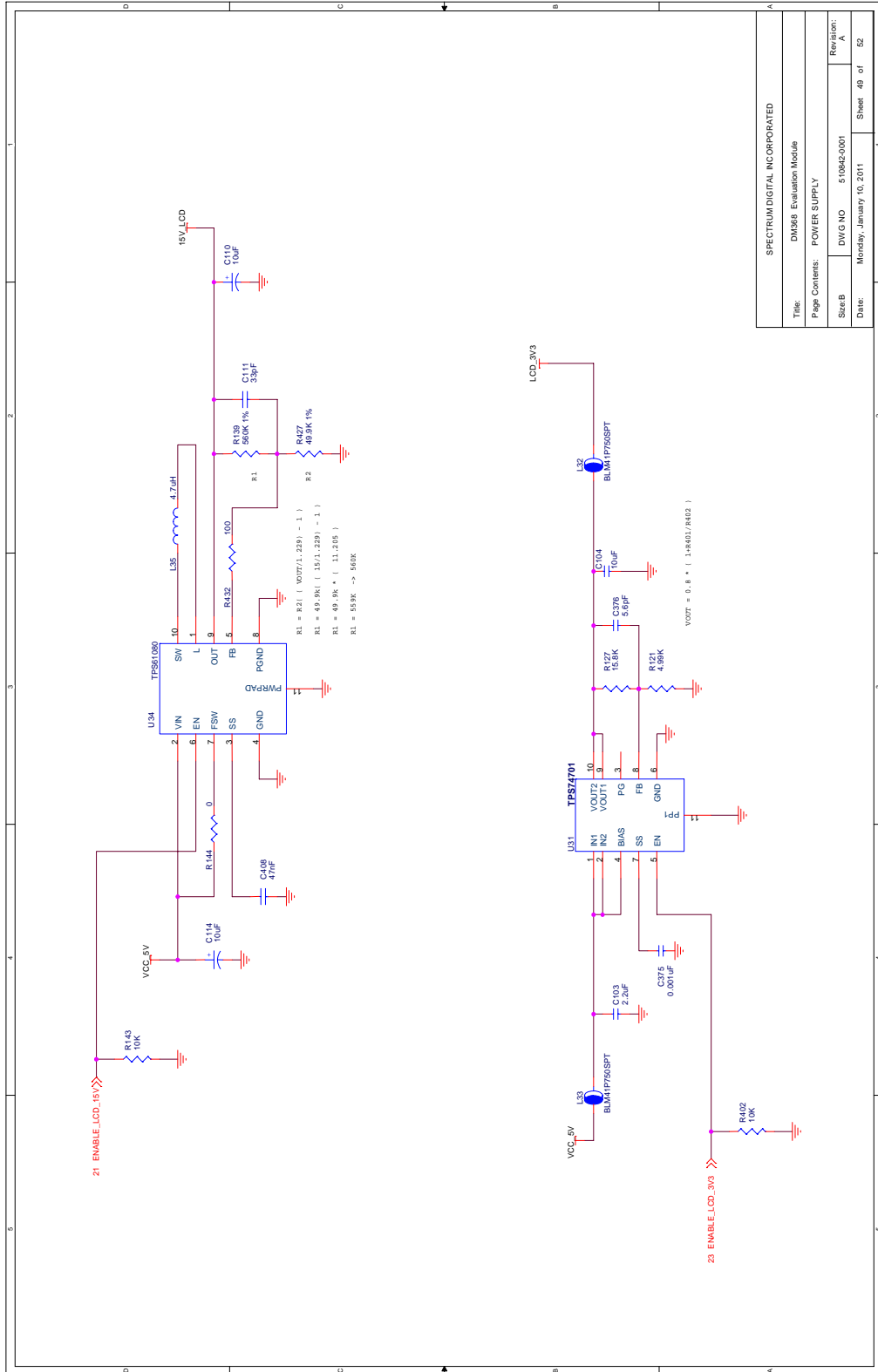

SPECTRUM DIGITAL INCORPORATED			
Title:	DM368 Evaluation Module		
Page Contents:	POWER SUPPLY		
Size/B	DWG NO	510842/001	Revision: A
Date:	Monday, January 10, 2011		Sheet 49 of 52

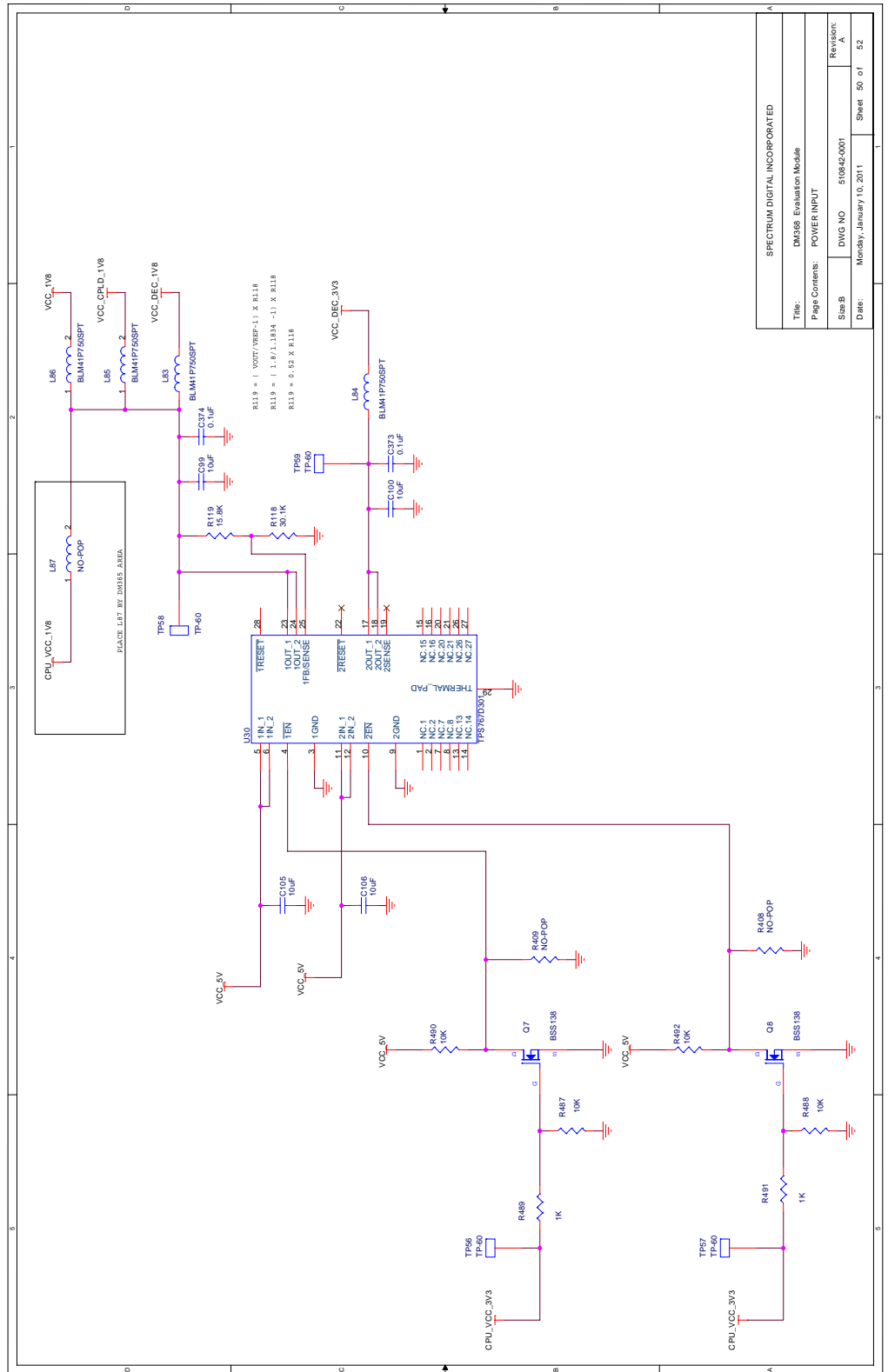

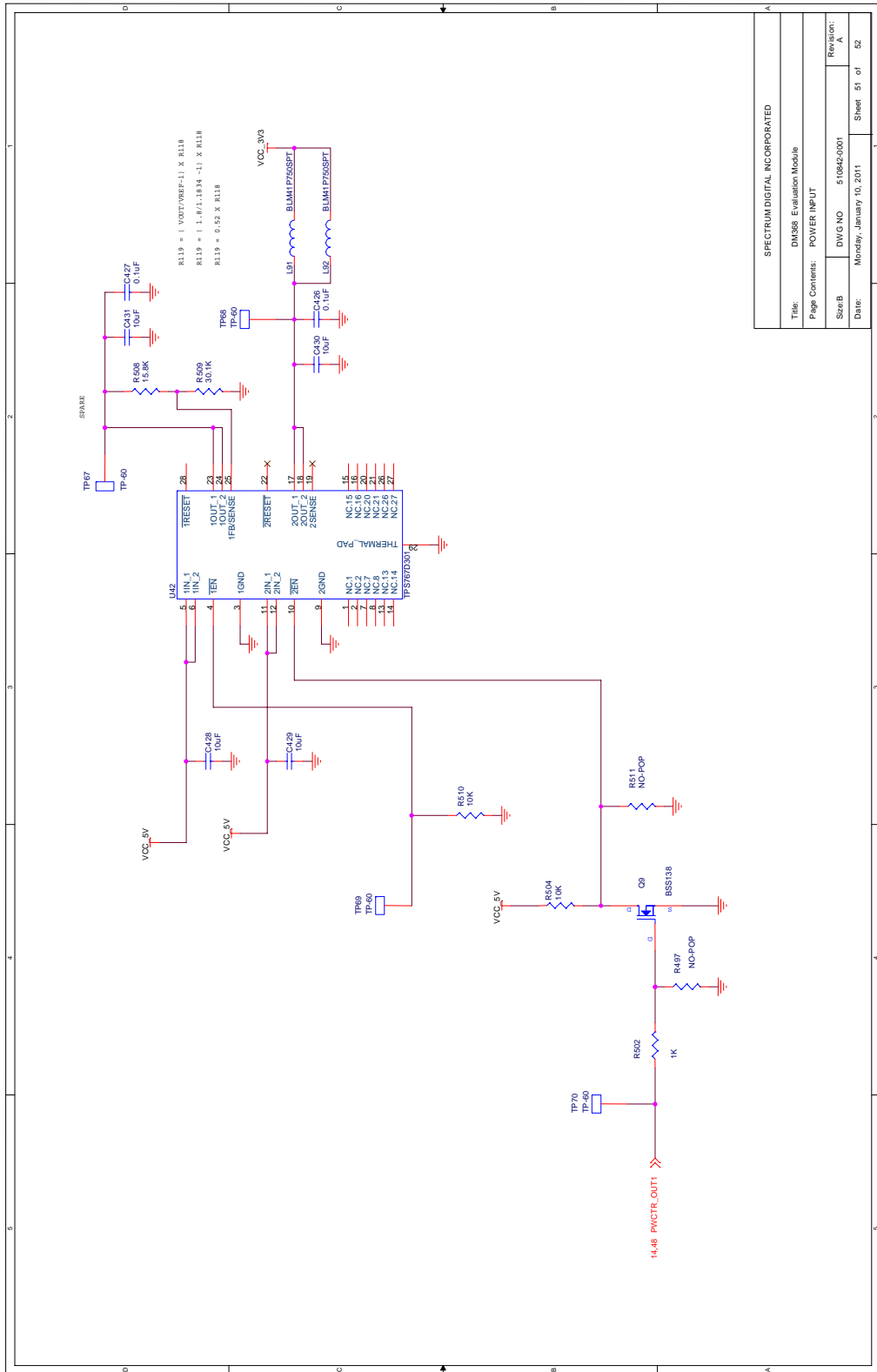

SPECTRUM DIGITAL INCORPORATED	
Title:	DM368 Evaluation Module
Page Contents:	POWER INPUT
SizeB	DWG NO 510842-0001
Date:	Monday, January 10, 2011
Sheet	51 of 52

REVISION E:
REVISION E is initial DM368 release. Previous Revisions were based on DM365

SPECTRUM DIGITAL INCORPORATED			
Title:	DM368 Evaluation Module		
Page Contents:	Revision Information		
Size:	B	DWG NO	510842/001
Date:	Monday, January 10, 2011	Revision:	12
			Sheet 52 of 52

Mechanical Information

This appendix contains the mechanical information about the DM368 EVM produced by Spectrum Digital.

