

Installation & Operation Manual

Version: 1.C

November 23, 2004

GM-TTT

Master Time Code Generator
Central Unit of the MTD Time-Timer-Time Code System



Alpermann+Velte

CONTENTS

| | | |
|-----------|---|-----------|
| A1 | REVISION HISTORY | |
| A2 | COPYRIGHT | |
| A3 | WARRANTY | |
| A4 | UNPACKING/SHIPPING/REPACKAGING INFORMATION | |
| A5 | SAFETY INSTRUCTIONS | |
| A6 | CERTIFICATIONS & COMPLIANCES | |
| | | |
| 1 | INTRODUCTION TO THE GM-TTT | 10 |
| 1.1 | OVERVIEW | 10 |
| 1.2 | OPTIONAL MODULES | 11 |
| 1.3 | APPLICATION DIAGRAMS | 12 |
| 1.4 | CONNECTIONS AT THE REAR AND TECHNICAL DATA | 13 |
| 1.5 | FUNCTIONS OF BUTTONS, OVERVIEW | 16 |
| 1.6 | STATUS INDICATION BY LED'S, OVERVIEW | 17 |
| 1.7 | THE MENU STRUCTURE, OVERVIEW | 19 |
| 1.8 | AFTER POWER-ON | 21 |
| 2 | MAIN OPERATING MODES | 23 |
| 2.1 | FUNDAMENTAL PRINCIPLES | 23 |
| 2.2 | <i>TIME</i> OPERATING MODE | 24 |
| 2.3 | <i>TIMER</i> OPERATING MODE | 25 |
| 2.4 | <i>TC</i> OPERATING MODE | 26 |
| 2.5 | <i>START</i> OPERATING MODE | 28 |
| 3 | DETAILED MENU DESCRIPTION | 29 |
| 3.1 | GENERAL DESCRIPTION | 29 |
| 3.2 | SET | 29 |
| 3.2.1 | SET START: Enter a Start Value | 29 |
| 3.2.2 | SET USER: Enter User Defined Data for the Binary Groups | 30 |
| 3.2.3 | SET TIME: Set the Time of the Internal Clock | 30 |
| 3.2.4 | SET DATE: Set the Date of the Internal Clock | 30 |
| 3.2.5 | USER MOD.: Data Content of the Binary Groups | 31 |
| 3.2.6 | LOCK: Genlock and Colour Lock Mode | 34 |
| 3.2.7 | F-RATE: Select Frame Rate and Television System | 34 |
| 3.2.8 | PARA: More System Parameters | 35 |
| 3.2.9 | FACTORY: Factory Reset | 35 |
| 3.3 | TIMER | 36 |
| 3.3.1 | TIME A-F: Installation of the <i>Timer</i> Operating Mode | 36 |
| 3.3.2 | U STORE / U LOAD / U RESET | 38 |
| 3.3.3 | A ... F: Display Timer A ... F | 38 |
| 3.4 | LTC | 39 |
| 3.4.1 | OUT: LTC Output Level | 39 |
| 3.4.2 | POLARITY: Select the Use of the Polarity Bit | 39 |
| 3.4.3 | 1: Display the LTC Flag Bits | 40 |

Installation & Operation Manual GM-TTT

Page 2

| | | |
|----------|--|-----------|
| 3.5 | VITC | 41 |
| 3.6 | STATUS | 42 |
| 3.7 | TEST | 43 |
| 3.8 | REFERENCE | 44 |
| 3.8.1 | MODE 1: Automatic Setting and DST Mode of the Internal Clock | 44 |
| 3.8.2 | MODE 2: Time for Automatic Setting of the Internal Clock | 46 |
| 3.8.3 | 1 ... 6: Status Data of the Reference Time | 47 |
| 3.9 | SERIAL | 49 |
| 3.9.1 | FORMAT: Select the Baud Rate and Format of the Serial Interface | 49 |
| 3.9.2 | PROTOCOL: Select the Remote Control Protocol | 49 |
| 3.10 | LTC IN | 50 |
| 3.10.1 | MODE: Settings for the Operation Mode Using External LTC | 50 |
| 3.10.2 | OFFSET: Offset Programming for the Time Information | 51 |
| 3.10.3 | 1 ... 3: Status Data of the Readout LTC | 51 |
| 3.11 | GPI | 52 |
| 3.11.1 | SET TIME: Pre-set the Comparative Time Value for Relay Switching | 52 |
| 3.11.2 | SET MODE: Set the GPI Mode | 52 |
| 3.12 | ZONE | 53 |
| 3.12.1 | OFFS 1: Time Zone Offset During Normal Time | 54 |
| 3.12.2 | OFFS 2: Time Zone Offset During Daylight Saving Time (DST) | 54 |
| 3.12.3 | DST on: Program the Beginning of the Daylight Saving Time | 55 |
| 3.12.4 | DST off: Program the End of the Daylight Saving Time | 55 |
| 3.12.5 | DST Period: Indicate Beginning and End of DST of the Current Year | 56 |
| 3.12.6 | RESET A - F: Reset the Parameters of the Time Zones for Timer A - F | 56 |
| 4 | GENLOCK | 57 |
| 4.1 | GENLOCK TO A BLACK-BURST OR VIDEO SIGNAL | 57 |
| 4.2 | GENLOCK TO A LTC SOURCE | 58 |
| 4.3 | GENLOCK TO A 1PPS SIGNAL | 59 |
| 5 | OPERATION WITH A REAL TIME REFERENCE | 60 |
| 5.1 | CONNECTION OF AN EXTERNAL REFERENCE | 60 |
| 5.2 | DCF IN OPTION: INSTALLATION OF A DCF77 RECEIVER | 61 |
| 5.3 | GPS IN OPTION: INSTALLATION OF A GPS RECEIVER | 62 |
| 5.4 | OPTION T: BATTERY-BUFFERED CLOCK MODULE | 64 |
| 5.5 | TIME TRANSFER DURING NORMAL OPERATION AND TIME JUMPS | 65 |
| 5.6 | INTERNAL CLOCK, AUTOMATIC DST MODE, BINARY GROUPS WITH DATE AND STATUS | 67 |
| 5.7 | REAL TIME COUPLING OF TIME CODE AND VIDEO | 68 |
| 6 | FURTHER DETAILS | 70 |
| 6.1 | FACTORY SETTINGS | 70 |
| 6.2 | MAINTENANCE | 72 |
| 7 | OPTIONAL MODULES AND FUNCTIONS | 73 |
| 7.1 | COLOUR LOCK | 73 |
| 7.2 | VITC GENERATOR | 74 |
| 7.3 | SERIAL REMOTE CONTROL INTERFACE | 75 |
| 7.3.1 | General | 75 |
| 7.3.2 | Commands | 76 |

| | | |
|-------|---|----|
| 7.4 | REFERENCE TIME INPUT VIA EXTERNAL LTC | 78 |
| 7.4.1 | General | 78 |
| 7.4.2 | Accepting Time, Date and Status Information of the External LTC | 78 |
| 7.4.3 | Examples | 79 |
| 7.5 | SECONDS AND MINUTES PULSE OUTPUT | 81 |
| 7.6 | ANALOGUE MASTER OUTPUT | 82 |

A1 Revision History

| No. | Date | Subject |
|-----|--------------------|---|
| 0.x | September 10, 2002 | Preliminary IBC-2002 document, supplementary data may be published soon. |
| 1.0 | October 31, 2002 | |
| 1.1 | November 04, 2002 | Headlines 3.12.1 and 3.12.2 exchanged. Diagram of chapter "6.2 Maintenance" revised. Some editorial changes. |
| 1.2 | March 18, 2003 | Extension of USER MODE: "A DATE-7". Chapter 7.4: Reference Time Input via External LTC. |
| 1.3 | March 28, 2003 | Correction at USER MODE: "A DATE-7": appointment code must be \$8 instead of \$1. |
| 1.4 | May 07, 2003 | Correction chap. 1.4, pinning GPI: COM1 = pin 6 (not pin 3). |
| 1.5 | June 10, 2003 | Extension of USER MODE: "b OFF". |
| 1.6 | June 30, 2003 | Option "2" (RS232) and Option "4" (RS422): add pinning of DSUB9 at chap. 1.4. Chapter 7.3.1: additional note: because of the missing RS485 interface to the control units of the MTD system, GM-TTT can no longer work as a central unit of this system. |
| 1.7 | July 08, 2003 | Option "P": addenda at chapters 1.2 and 1.4, new chapter 7.5. |
| 1.8 | August 22, 2003 | Extension of GPI feature, chapter 3.11: timer time to trigger can be C, D, E or F as well. |
| 1.9 | November 20, 2003 | Range of VITC lines changed, chapter 3.5 and 7.2. Editorial changes at chapter 3.12.3 and 3.12.4. |
| 1.A | December 08, 2003 | Option "A": addenda at chapters 1.2 and 1.4, new chapter 7.6. |
| 1.B | February 05, 2004 | New submenu "PARA": main operating mode <i>start</i> programmable. |
| 1.C | November 23, 2004 | Chapter 3.2.5: new formats of setting the date in the binary groups. |

A2 Copyright

Copyright © Alpermann+Velte Electronic Engineering GmbH 2002. All rights reserved. No part of this publication may be reproduced, translated into another language, stored in a retrieval system, or transmitted, in any form or by any means, electronic, mechanical, photocopying, recording, or otherwise without the prior written consent of Alpermann+Velte Electronic Engineering GmbH.

Printed in Germany.

Technical changes are reserved.

All brand and product names mentioned herein are used for identification purposes only, and are trademarks or registered trademarks of their respective holders.

Information in this publication replaces all previously published information. Alpermann+Velte Electronic Engineering GmbH assumes no responsibility for errors or omissions. Neither is any liability assumed for damages resulting from the use of the information contained herein.

For further information please contact your local dealer or:

Alpermann+Velte

Electronic Engineering GmbH

Otto-Hahn-Str. 42

D-42369 Wuppertal

Phone: ++49 - (0)202 - 244 111 0

Fax: ++49 - (0)202 - 244 111 5

E-Mail: info@alpermann-velte.com

Internet: <http://www.alpermann-velte.com>

A3 Warranty

Alpermann+Velte warrants that their products will be free from defects in materials and workmanship for a period of two years from the date of shipment. If this product proves defective during the warranty period, Alpermann+Velte, at its option, will repair or replace the defective product without charge, provided this product are returned to Alpermann+Velte freight prepaid.

In order to obtain service under this warranty, Customer must notify Alpermann+Velte of the defect before expiration of the warranty period and make suitable arrangements for the performance of service. Customer shall be responsible for packaging and shipping the defective product to Alpermann+Velte, please notice the Shipping Information given below.

This warranty shall not apply to any defect, failure or damage caused by abuse, misuse, improper use, negligence, accident, modification, alteration, or improper or inadequate maintenance and care.

This warranty is given by Alpermann+Velte with respect to this product in lieu of any other warranties, express or implied. Alpermann+Velte and its vendors disclaim any implied warranties of merchantability or fitness for a particular purpose. Alpermann+Velte's responsibility to repair or replace defective products is the sole and exclusive remedy provided to the customer for breach of this warranty. Alpermann+Velte and its vendors will not be liable for any indirect, special, incidental, or consequential damages irrespective of whether Alpermann+Velte or the vendor has advance notice of the possibility of such damages.

A4 Unpacking/Shipping/Repackaging Information

This product has been carefully inspected, tested and calibrated before shipment to ensure years of stable and trouble-free service.

The shipping carton and pads provide protection for the product during transit. Retain the shipping cartons in case subsequent shipment becomes necessary.

Carefully unpack the product from its transit material and carefully check the product for signs of damage. In the event that the product has been damaged during transit, contact the carrier and your Alpermann+Velte dealer.

Please confirm that all items listed on the packing list have been received. Check the items against your original order to ensure that you have received the correct parts. If any item is missing, please contact your Alpermann+Velte dealer.

Ensure that all packaging material is removed from the product and its associated components before installing the unit.

Products returned to Alpermann+Velte for servicing or repair should have a tag attached showing:

- Name and complete address of the owner and the name of the person that can be contacted.
- Units serial number and a description of the service required or failure detected.

Products returned should be shipped prepaid in the original packaging material if possible. If the original packaging is not available or is unfit for use, supply an adequate packaging which should meet the following criteria:

- Packaging must be able to withstand the product weight.
- Product must be held rigid within the packaging.
- Allow at least two inches of space between the product and the container.
- The corners of the product must be protected.
- Seal the carton with shipping tape or an industrial stapler.

If the product is still within the warranty period, the product will be returned by prepaid shipment after servicing.

A5 Safety Instructions

The general safety information in this part is for both operating and service personnel. Alpermann+Velte products are only to be used as directed. Specific warnings and cautions will be found throughout the manual where they apply.

Review the following safety instructions to avoid injury and prevent damage to this product or any products connected to it.

- Read these instructions.
- Keep these instructions.
- Heed all warnings.
- Follow all instructions.

Safety Terms and Symbols

Terms and Symbols in this manual:



CAUTION: Caution statements identify conditions or practices that could result in damage to this product or other property.

Terms and Symbols which may be found on the product:



ATTENTION: Refer to the manual.



Observe precautions for handling electrostatic-sensitive devices.



Signal Ground.

Product Damage Precautions

PREVENT OVERHEATING



To prevent product overheating, position the unit only where sufficient air circulation can be maintained. Good air circulation is essential to prevent internal heat build-up, do not block any ventilation openings. Do not expose the unit to direct sun light or any other strong lights. Keep the unit away from heat sources.

PROVIDE PROPER ENVIRONMENT



Dust, humidity, shocks and strong electromagnetic fields must be avoided. Do not expose this apparatus to dripping or splashing water. Ensure that no objects filled with liquid are placed on the apparatus.

OBSERVE EMC REGULATIONS



The EMC regulations are observed only under the following condition: use high quality shielded cables at data inputs and outputs.

SUSPECTED FAILURES



Whenever it is likely that safe operation is impaired, the apparatus must be made inoperative and secured against unintended operation. The appropriate service authority must then be informed. Do not operate with suspected failures. Servicing is required when the apparatus has been damaged in any way, such as power-supply is damaged, liquid has been spilled or objects have fallen into the apparatus, the apparatus has been exposed to rain or moisture, does not operate normally, or has been dropped.

PREVENTIVE MAINTENANCE: CLEANING



Qualified Service Personnel Only: The apparatus should be cleaned often enough to prevent dust or dirt from accumulating. Dust accumulating in the apparatus acts as an insulating blanket, preventing proper cooling, and possibly causing overheating and component breakdown. Under high humidity conditions, accumulated dust can also provide an electrical conduction path. Remove accumulated dust with a soft cloth or small paint brush. Remove hardened dirt with a soft cloth, dampened in a mild detergent and water solution. Do not use polish or abrasive cleaners or any other chemical cleaning agents.

PREVENTIVE MAINTENANCE: VISUAL INSPECTION



Qualified Service Personnel Only: Visually inspect the apparatus for signs of damage, scorched components, and loose or disconnected pin connectors. If you discover heat damaged parts, try to determine the cause of the overheating before replacing the damaged parts; otherwise, the damage may repeat.

ATTENTION:



Observe precautions for handling electrostatic-sensitive devices. See "Electro Static Discharge (ESD) Precautions" below for details.

Electro Static Discharge (ESD) Precautions



All semiconductor devices are sensitive to ESD. To prevent any damage or degradation on components of the product caused by ESD, observe these precautions when directed to do so (installing, removing sensitive components):

1. Use a Ground Strap. Wear a grounded anti-static wrist or heel strap to discharge the static voltage from your body.
2. Use a Safe Work Area. Avoid handling components in areas that have a floor or work surface covering capable of generating a static charge. Also nothing capable of generating or holding a static charge should be allowed in the work area.
3. Handle ESD sensitive components carefully. Do not slide components over any surface. Do not touch exposed connector pins. Pick-up components by the body, never by the leads.
4. Transport and store sensitive components or assemblies in a static-protected bag or container.

Battery Use Warnings



CAUTION: Danger of explosion if battery is incorrectly placed. Replace only with the same or equivalent type recommended by the manufacturer. Discard used batteries according to the manufacturer's instructions.

A6 Certifications & Compliances

CE-Declaration:

We,

Alpermann+Velte
Electronic Engineering GmbH
Otto-Hahn-Str. 42
D-42103 Wuppertal

herewith declare under our sole responsibility that the

GM-TTT

meets the intent of the following directives, standards and specifications:

89/336/EEC Electromagnetic Compatibility

EN 50081-1 Emissions

- EN 55022
- EN 55103-1

EN 50082-1 Immunity

- EN 55024
- EN 55103-2

1 Introduction to the GM-TTT

1.1 Overview

The **GM-TTT** generates linear time code (LTC) and can also optionally generate a vertical interval time code (VITC). The frames/second can be selected from most widely used formats including 24, 25, 30 and 30 drop frame. The unit generates time code according to the SMPTE standard ANSI/SMPTE 12M-1995 (revision of ANSI/SMPTE 12M-1986) for the television systems 625/50 (PAL) and 525/60 (NTSC).

Time and binary groups information are displayed on the 8-digits front display panel. Time and binary groups can be pre-set by using buttons on the front panel, by an external LTC or by an external reference signal (for e.g. receiving time and date from a DCF77 or GPS receiver). With the Alpermann+Velte MTD system the time may also be set from one of the six internal timers A - F (described below).

The LTC signal can be phase-locked to it's own internal reference (x'tal, temperature compensated) or to an external genlocking signal (video or black-burst television signal, external LTC source, real time seconds pulse).

GM-TTT was designed for video studios and broadcast stations. External synchronising signals pass through special filters, so that noise or other disturbances in these signals do not affect the time code output. This ensures that the time code is permanently available, continuously up-counting, and without any faults even if there is a drop-out of the external synchronising signal. Further effort has been made to professionally handle the real time coupling. The unit supplies all information required to adjust the time code and the SPG (sync pulse generator) to a real time reference signal. Real time references presently include GPS or DCF77 receivers.

GM-TTT is a master time code generator and the central unit of the Alpermann+Velte MTD system at the same time. *Alpermann+Velte* has uniquely developed a system we call the Multiple Time Display System (MTD). This system supplies the video studio with time information as local time, date, time code, VTR time code, up/down counting timers etc. A MTD system consists of a central generator, digital displays and/or index clocks and at least one control unit. The central generator generates a specific LTC format which will be referred to as LTC(MTD) in this document. The LTC(MTD) transfers data to all digital displays and includes all the time information that were mentioned above. The control units communicate with the central generator via a RS485 bus and are connected to the LTC (MTD)/RS485 connector.

The front panel of a **GM-TTT** has buttons and a display, these are necessary to configure and operate the unit. All important functions may be switched easily and quickly by using these buttons. A KEYLOCK function is available to avoid unintentional key presses (used after an application has been properly set-up and changes are no longer needed).

1.2 Optional Modules

The following options are available:

| | |
|---|---|
| V: VITC generator | <ul style="list-style-type: none"> VITC contains the same time and binary groups information as the LTC. |
| C: Colour lock for the 625/50 (PAL) television system | <ul style="list-style-type: none"> 4-field and 8-field, 8-field using the white flag of line 7 of a black-burst input. |
| L: LTC play speed reader, 80-bit and 112-bit code | <ul style="list-style-type: none"> LTC Jam-Sync functions, LTC refresh and regeneration, LTC source synchronisation, display of the VTR-LTC in the MTD system, converter of a 112-bit code to a 80-bit code. |
| G: GPI | <ul style="list-style-type: none"> Relay closure at a programmable time. |
| 2: RS232 4: RS422 | <ul style="list-style-type: none"> Instead of the RS485 interface used to communicate within the MTD system a RS232 or RS422 serial interface can be used to remote control the unit. |
| P: Pulse outputs | <ul style="list-style-type: none"> Seconds pulse output and minutes pulse output. |
| A: Analogue Master Output | <ul style="list-style-type: none"> Output to drive analogue clocks with hands. |
| * | <p>Special solutions:</p> <ul style="list-style-type: none"> Additional independent unbalanced LTC output (at BNC). Special software according to customer's need. Special hardware according to customer's need. |

Additionally there are the following configurations to realise a reference time input. The reference time can set the internal clock at various user definable terms.

| | |
|--|---|
| DCF IN: DCF77 radio clock receiver built-in | <ul style="list-style-type: none"> Reference time = Central European Time (CET/CEST) transmitted from the German DCF77 transmitter. |
| GPS IN: GPS receiver built-in | <ul style="list-style-type: none"> Reference time = a time derived from the GPS time, e.g. the UTC. |
| Standard: Interface to connect an external DCF77 or GPS receiver | <ul style="list-style-type: none"> Input second pulse and serial data of an appropriate external unit. |
| T: Built-in real time clock module | <ul style="list-style-type: none"> Time and date will be set by the buttons of GM-TTT. The module has a real time clock with a battery backup. |

1.3 Application Diagrams

Redundant Master Time Code System with Reference Time Input and 10MHz Genlocking

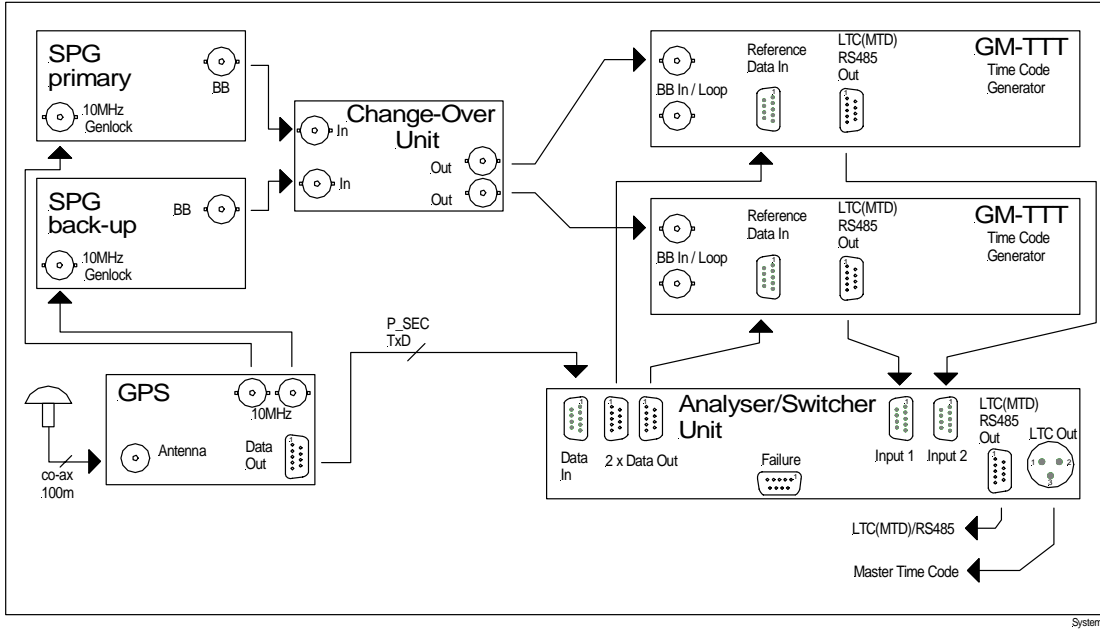

Central Unit of the MTD Time-Timer-Time Code System

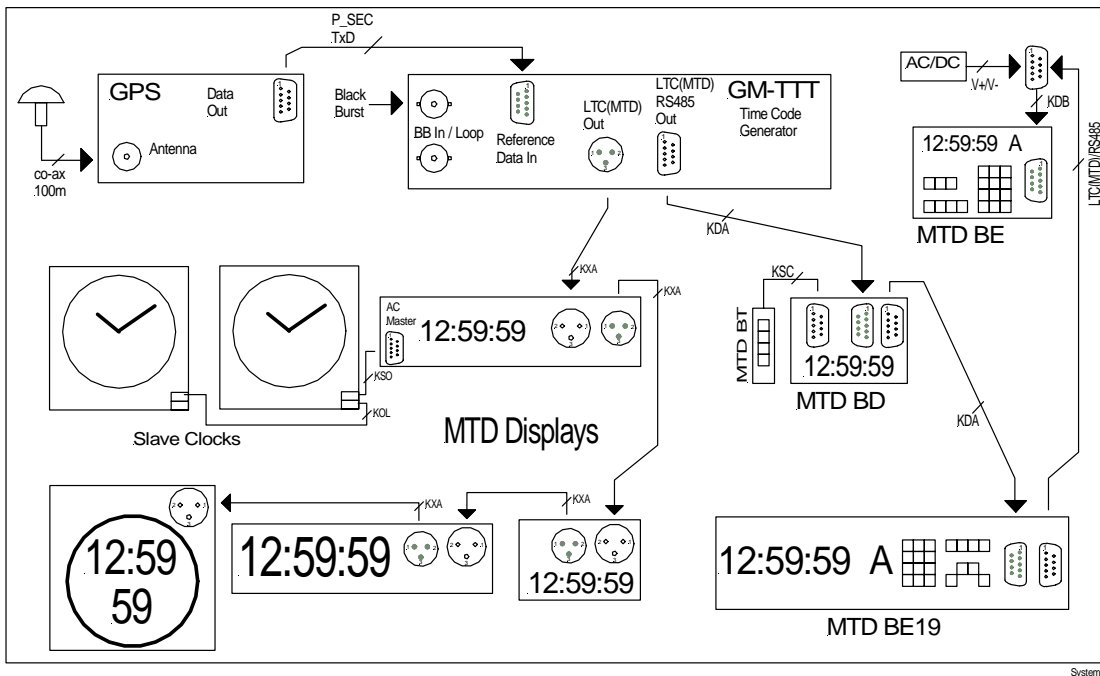

1.4 Connections at the Rear and Technical Data

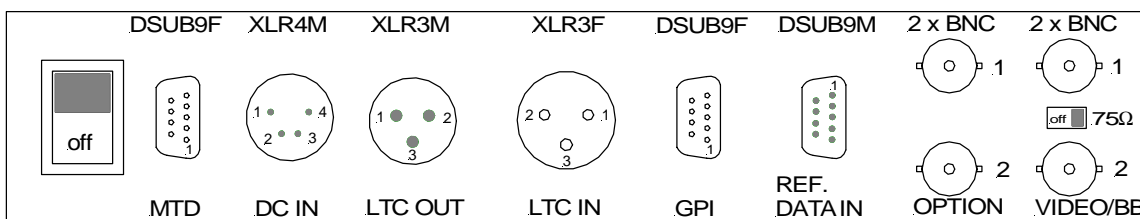

Dimensions: 214.5 (W) x 43.5 (H) x 140 (D) mm (½ 19", 1U)
 Weight: 1.5 kg approx.
 Operating temperature: 5 °C to 40 °C
 Relative humidity: 35% to 85%, non-condensing

| | | | |
|--|---|---|---|
| MTD LTC(MTD)/RS485 connector Specifications for LTC_x/LTC_y see LTC OUT | Pin 1: RS485 TRA (input/output) Pin 2: RS485 TRB (input/output) Pin 3: LTC_x (output) Pin 4: LTC_y (output) Pin 5: GND Pin 6-8: reserved Pin 9: DRVSEL | | |
| Instead of LTC(MTD)/RS485 signals: pinning in case of option "2" (RS232) or option "4" (RS422) | <table style="width: 100%; border-collapse: collapse;"> <tr> <td style="width: 50%; border-right: 1px solid black; padding-right: 5px;"> Option "2" (RS232): 2: RxD (in) 5: GND 3: TxD (out) 7: RTS (out) 4: DTR (out) 8: CTS (in) 1, 6, 9: not connected </td> <td style="width: 50%; padding-left: 5px;"> Option "4" (RS422): 1, 5: n.c. 6: TxC 2: TxB (out) 7: TxA (out) 3: RxA (in) 8: RxB (in) 4: RxC 9: frame </td> </tr> </table> | Option "2" (RS232): 2: RxD (in) 5: GND 3: TxD (out) 7: RTS (out) 4: DTR (out) 8: CTS (in) 1, 6, 9: not connected | Option "4" (RS422): 1, 5: n.c. 6: TxC 2: TxB (out) 7: TxA (out) 3: RxA (in) 8: RxB (in) 4: RxC 9: frame |
| Option "2" (RS232): 2: RxD (in) 5: GND 3: TxD (out) 7: RTS (out) 4: DTR (out) 8: CTS (in) 1, 6, 9: not connected | Option "4" (RS422): 1, 5: n.c. 6: TxC 2: TxB (out) 7: TxA (out) 3: RxA (in) 8: RxB (in) 4: RxC 9: frame | | |
| DC IN Power Consumption: without additional options = 3 W; maximal = 8 W. | Pin 1: V- (GND) Pins 2/3: not connected Pin 4: V+: 10 - 30 V DC (except with option "A": 10 - 18 V DC) | | |
| LTC OUT LTC_x/LTC_y: LTC signal, balanced. <ul style="list-style-type: none"> Level: 35 mV_{pp} - 3 V_{pp} adjustable. Impedance: < 50 Ω. Frequency stability (sync = intern): ≤ 3 ppm, adjustable by pot. | Pin 1: GND Pin 2: LTC_x (output) Pin 3: LTC_y (output) | | |
| LTC IN (option L) LTC_x/LTC_y: LTC signal, balanced. <ul style="list-style-type: none"> Level 50 mV_{pp} - 5 V_{pp} auto-ranging. Impedance: > 12 kΩ. LTC input frequency: 1500 - 3000 bps = 19 - 37 frames/s 80-bit code, = 14 - 26 frames/s 112-bit code. | Pin 1: GND Pin 2: LTC_x (input) Pin 3: LTC_y (input) LTC input accepted for genlocking: frame rate = 24: 24 frames/s ±1.4%, frame rate = 25: 25 frames/s ±1.5%, frame rate = 30: 30 frames/s ±1.8%. | | |

Installation & Operation Manual GM-TTT

| GPI | |
|---|--|
| Option G: Relay points Switcher COM1-NC1 (Normally Closed) and COM1-NO1 (Normally Open). <ul style="list-style-type: none"> • Max. switchable power: 5 W. • Max. switchable voltage: 175 V. • Max. switching current: 0.25 A • Max. transportable current: 1 A | Pin 1: NC1 Pin 2: NO1 Pin 6: COM1 |
| Option P: Pulse outputs TTL level pulses | Pin 3: Seconds pulse Pin 4: Minutes pulse Pin 5: GND |
| Option A: Power supply and data telegram to drive analogue clocks. | Pin 1: V+ Out Pin 2: V- Out Pin 7: Signal Out Pin 8: Signal GND |

| | |
|--|--|
| REF. DATA IN Interface for the external reference time input, it is missing in case of a built-in reference. P_SEC: 1pps signal (seconds pulse), internal trigger at rising or falling edge according to selection (menu REFER - MODE 1). Input low: max. 0.8 V. Input high: 2-15 V. RxD: Serial data protocol with fixed format (Meinberg): 2400/7/E/2. Input low: max. 0.8 V. Input high: 2-15 V. | Pin 1: P_SEC Pin 2: RxD Pin 5: GND |
| With option GPS IN: DSUB9M "DC GPS IN" | Pin 6: V+ = 11 - 30 VDC, 2W Pin 7: V- (GND) |

| OPTION 1 | |
|---|-----------|
| With option DCF IN: BNC antenna input. | BNC, 50 Ω |
| With option GPS IN: SMA antenna input. | SMA |

| OPTION 2 | |
|---|-----------------------|
| With option V (VITC generator): video + VITC output, according to SMPTE 12M-1995. Video output: gain = 1 ±1%. | BNC (IEC 169-8), 75 Ω |

| | |
|--|--|
| <p>VIDEO/BB Input + loop-through of a CVBS or black-burst signal. Set 75 Ω termination switch to "on" position if the loop-through should be left open. With option V (VITC generator) the video input level should have $1V_{pp} \pm 15$ mV. Using this input only for video genlock the sync amplitude should have 300 mV ± 6 dB.</p> | <p>2 x BNC (IEC 169-8), 75 Ω</p> |
|--|--|

1.5 Functions of Buttons, Overview

| BUTTON | FUNCTION |
|------------------|--|
| <i>menu</i> | Switching on/off the menu lines. |
| ↑ ↓ → | Buttons to operate in the menu, see detailed menu description. |
| <i>enter</i> | Button to operate in the menu, see detailed menu description. Pressed if menu is switched off: status display, the display shows type of the unit, configuration and software revision in same steps as after power-on. |
| <i>time/user</i> | Switches the display to show the time or binary groups information of the time code. Terminates any menu operation. |
| <i>key lock</i> | Switching on (LED lights up) or off (LED off) the Key Lock feature. Key Lock "on" means: the buttons <i>enter</i> , <i>intern</i> , <i>genlock</i> , <i>time</i> , <i>timer</i> , <i>tc</i> and <i>start</i> are without function. So an unintentional key stroke do not lead to an unwanted function, only the display can be switched. Setting time or date using an operational unit of the MTD system is disabled. |
| <i>intern</i> | Switches on the genlock to internal reference signal (temperature compensated x'tal). |
| <i>genlock</i> | Switches on the genlock to the input source as selected at the menu SET - LOCK. Input genlock can be one of three sources: video or black-burst, LTC input signal, seconds pulse of a real time reference. |
| <i>time</i> | Select LTC generator operating mode: reference time input. The LTC time information corresponds to the reference time input (\pm offset as selected at the menu ZONE - OFFS1 and OFFS2). With every key stroke the generator synchronises again to the reference time, so the generator is forced manually to a synchronisation additional to the automatic synchronisation as selected at the menu REFER - MODE1 and MODE2. |
| <i>timer</i> | Select LTC generator operating mode: time of a MTD timer. The LTC time information corresponds to one of the MTD timer A - F, as selected at the menu TIMER - TIME A-F. |
| <i>tc</i> | Select LTC generator operating mode: LTC Jam-Sync feature. Transfers data from LTC input to LTC output, as selected at the menu LTC IN - MODE. |
| <i>start</i> | Select LTC generator operating mode: free-running mode. If enabled at submenu SET - ... - PARA: with every further key stroke the time value which has last been chosen as a start value (menu SET - START) will be transferred to the LTC time information, and the generator keeps on counting continuously from this start value on. |

1.6 Status Indication by LED's, Overview

| LED | FUNCTION |
|------------------|---|
| <i>time/user</i> | <p>On: the display shows the time information of the time code (provided the menu has been switched off).</p> <p>Off: the display shows the binary groups information of the time code (provided the menu has been switched off).</p> |
| <i>key lock</i> | <p>On: <i>Key Lock</i> enabled.</p> <p>Off: <i>Key Lock</i> disabled.</p> |
| <i>intern</i> | <p>On: genlock to <i>internal reference</i> selected.</p> <p>LED lights up as well if genlock = <i>seconds pulse</i> is selected and the generator currently stays in a coarse trim.</p> |
| <i>genlock</i> | <p>Case genlock = <i>video</i> or <i>black-burst</i> selected at menu SET - .. - LOCK: Lights up if genlock is operating normally. Flashes if the genlock signal is disturbed and the internal reference is currently selected. If the genlock signal returns to be ok the LED will light up again.</p> <p>Case genlock = <i>LTC input signal</i> is selected at menu SET - .. - LOCK: Lights up if genlock is operating normally. Flashes if the genlock signal is disturbed or the frequency of the LTC input signal is beyond the specified range, then the internal reference is currently selected. If the genlock signal returns to be ok the LED will light up again.</p> <p>Case genlock = <i>seconds pulse</i> is selected at menu SET - .. - LOCK: Lights up if genlock is operating normally. This only can be achieved if the seconds pulse is stable, i.e. the jitter must not exceed 1.2ms. Flashes if the genlock signal is disturbed or the generator currently stays in a coarse or fine trim. The coarse trim will be indicated by LED <i>intern</i> as well. Coarse trim means: frame 0 of the time code is more than 16ms apart from the seconds pulse. Fine trim means: frame 0 of the time code is between 1.2ms and 16ms apart from the seconds pulse.</p> |
| <i>time</i> | Indicates the LTC generator operating mode: reference time input. |
| <i>timer</i> | Indicates the LTC generator operating mode: time of a MTD timer. |
| <i>tc</i> | Indicates the LTC generator operating mode: LTC Jam-Sync feature. LED lights up if LTC input is accepted, else LED flashes. |
| <i>start</i> | Indicates the LTC generator operating mode: free-running mode. |

Installation & Operation Manual GM-TTT

| | |
|-------------|--|
| <i>free</i> | Indicates the status of the reference time input: On: the serial data input indicates a free running mode, for example a GPS or DCF77 receiver has not locked to the antenna signal. Off: the reference time source has locked to the antenna signal. Only with option GPS IN: a flashing LED indicates the number of satellites found by the receiver. |
| <i>mod.</i> | LED flashes every time that serial data of a reference time input has been received. In normal operation that will be a flash every second. Only with option DCF IN: LED indicates the time telegram, this should be a flash every second as well - with no flicker in between. At the 59 th second the flash will be suppressed. |
| <i>cf</i> | Off: no colour lock mode selected. On: colour lock mode is selected and the corresponding flag bit of the time code is set, if V8 (8-field) lock is reached in the 625/50 system. Flashing slowly: colour lock mode is selected and V4 (4-field) lock is reached in the 625/50 system. Flashing fast: colour lock mode is selected but no colour lock can be reached. |
| 25 | On: frame rate = 25 (television system 625/50). LED off + LED 30 off: frame rate = 24. |
| 30 | On: frame rate = 30 Drop Mode (television system 525/60). Flashing: frame rate = 30. LED off + LED 30 off: frame rate = 24. |

1.7 The Menu Structure, Overview

| | | |
|--------|-----------|---|
| SET | SET START | Enter a start value of the time code generator. |
| | SET USER | Enter user defined data for the binary groups of the time code. |
| | SET TIME | Set the time of the internal clock. |
| | SET DATE | Set the date of the internal clock. |
| | USER MOD. | Select what kind of information should appear in the binary groups. |
| | LOCK | Select the genlock and the colour lock mode. |
| | F-RATE | Select frame rate and television system. |
| | PARA | More system parameters. |
| | FACTORY | Factory reset, all current parameters except 'user area' and 'time zone parameters' can be reset to default values. |
| TIMER | TIME A-F | Select a MTD timer (A ... F or Main Timer 1) and timer mode for the <i>timer</i> operating mode. |
| | U STORE | All current settings including the parameters set from a MTD operational unit can be stored to an 'user area'. |
| | U LOAD | The parameters stored in an 'user area' can be loaded, the unit will be forced to start anew. |
| | U RESET | The parameters stored in an 'user area' can be reset to default values. |
| | A (data) | Display timer A (test purpose only). |
| | B (data) | Display timer B (test purpose only). |
| | C (data) | Display timer C (test purpose only). |
| | D (data) | Display timer D (test purpose only). |
| | E (data) | Display timer E (test purpose only). |
| | F (data) | Display timer F (test purpose only). |
| LTC | OUT | Select the LTC output level. |
| | POLARITY | Select the use of the polarity bit. |
| | 1 (data) | Display the six time code flag bits of the LTC generator. |
| VITC | | Enter the VITC set mode. |
| STATUS | 1 (data) | Display internal register for test purposes. |
| | 2 (data) | Display CPU efficiency and ports. |
| | 3 (data) | Display current programming of the internal reference signal. |
| | 4 (data) | Display error counter: all faulty events of the genlock signal. |
| | 5 (data) | Display error counter: failures of the genlock signal. |

Installation & Operation Manual GM-TTT

| | | |
|--------|--------------|--|
| | 6 (data) | Display error counter: disturbances at the genlock signal. |
| | 7 (data) | Display internal register for test purposes. |
| | 8 (data) | Display internal register for test purposes. |
| TEST | (data) | Display delay between internal and external genlock signal. |
| | (data) | Display period of the external genlock signal. |
| | (data) | Display delay between second pulse and video or black-burst genlock signal. |
| REFER | MODE 1 | Automatic setting and DST mode of the internal clock. |
| | MODE 2 | Time for automatic setting of the internal clock. |
| | 1 (data) | Indication of the time of the reference time. |
| | 2 (data) | Indication of the date of the reference time. |
| | 3 (data) | The last time, when the data of the reference time showed the "lock" status. |
| | 4 (data) | The last date, when the data of the reference time showed the "lock" status. |
| | 5 (data) | Offset between the reference time and the internal clock. |
| | 6 (data) | Status information resulting from the data of the reference time. |
| SERIAL | FORMAT | Select the baud rate and format of the serial interface (option). |
| | PROTOCOL | Select the remote control protocol (option). |
| -- | | Reserved. |
| LTC IN | MODE | Settings for the operation mode using external LTC. |
| | OFFSET | Offset programming for the time information. |
| | 1 (data) | Indication of the readout LTC time. |
| | 2 (data) | Indication of the binary groups of the readout LTC |
| | 3 (data) | Indication of the current six flag bits of the readout LTC |
| GPI | SET TIME | Pre-set the comparative time value for GPI relay switching. |
| | SET MODE | Set the GPI mode. |
| ZONE | OFFS 1 | Time zone offset during normal time. |
| | OFFS 2 | Time zone offset during Daylight Saving Time (DST). |
| | DST on | Program the beginning of the DST. |
| | DST off | Program the end of the DST. |
| | (DST period) | Indicate beginning and end of DST of the current year. |
| | RESET A-F | Reset the parameters of the time zones for the timer A - F. |

1.8 After Power-On

After switching on the unit the data of the non-volatile memory will be tested. If the test fails the display shows "RESET" and the factory values will be stored. If the test passes the unit will be set into same state as before switching off.

After this test the display shows status messages in three steps. At same time all LED's illuminate for test purposes. Steps 1 and 2 show the hardware and software configuration, step 3 the result of the check of the time zone parameters of the MTD timers A - F.

Step 1, display shows e.g.:

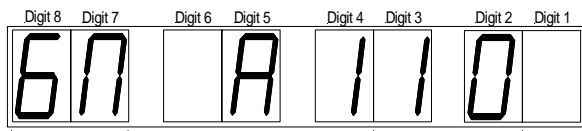

Digits 8 and 7 indicates the type of the unit: "GM".

Digit 5 shows if there are any modules plugged. Digit 5 shows a hexadecimal number, with following meanings of the single bits:

Bit 0: = 1, if VITC generator is plugged.

Bit 1: = 1, if any serial interface (RS485, RS232, RS422) is plugged.

Bit 2: = 1, if colour lock module is plugged.

Digit 4 shows the current selection of the USER MODE.

Digits 3 and 2 shows the software revision (e.g. 1.0).

Digit 1 = blank in a standard configuration. Any special configuration will be indicated by an 'o' at this place.

Step 2, display shows e.g.:

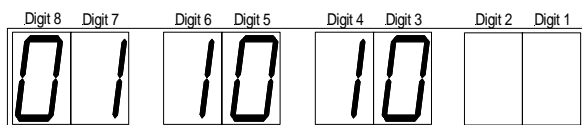

Digit 8: = 1, if the remote control via serial interface is basically enabled.

Digit 7: reserved.

Digit 6: = 1, if the Real Time Reference operation is basically enabled.

Digits 5..3 = blank if digit 6 = 0, else:

Digit 5: indicates the kind of serial interface used to receive real time data (DCFSIO).

Digit 4 = 0: no use of a real time seconds pulse.

= 1: seconds pulse is used, rising edge.

= 2: seconds pulse is used, falling edge.

Digit 3: indicates the protocol used to receive real time data.

Digits 2 and 1 identifies any special configuration by two numbers.

Installation & Operation Manual GM-TTT

Page 22

Step 3, display shows e.g.:

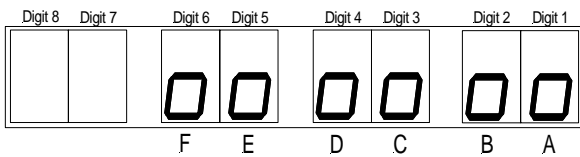

The time zone parameters of the MTD timer A ... F has been checked. The display shows the result: an "o" means ok, "n" means parameter check failed, this time zone has been reset to standard values. Digit 1 refers to time A etc.

The internal clock is set to time = 00:00:00 and date = 01.01.2002. Now the unit tries to lock to the selected genlock mode. At the same time measurements are made to analyse the timing between the incoming reference data (P_SEC, serial data) and the LTC output frames. The LTC output still will be "quiet", the goal is to start the LTC with a locked frequency and with valid data (internal clock locked to a reference time). With the operating mode = *time* it will take about 18 seconds to have everything locked and to enable the LTC output.

2 Main Operating Modes

2.1 Fundamental Principles

GM-TTT can be used in different applications, as there are:

- generating a stable master LTC and VITC,
- real time, local time, time zone applications,
- converter LTC-to-LTC and/or LTC-to-VITC,
- central unit of a timer system,
- and more.

GM-TTT is able to handle some of these applications simultaneously. To use the unit most effective and perfect, it is important to understand, how the unit works. The operator should be aware of the following four subjects:

LTC output frequency

The LTC output is a kind of an audio signal with a specific frequency. This signal should be as accurate and stable as possible. It can be locked to an external signal. This feature will be adjusted by *frame rate* selection and *intern/genlock* selection.

Internal clock

The unit has an internal clock counting time and date. This clock can be set by a built-in or external reference time. The time (and date) can be transferred to the bits of the (standard) LTC, time and date are also accessible as data of the LTC(MTD). Time zone and Daylight Saving Times (DST) features can give the internal clock a different time compared to the reference, this programming is done in the *REFER.* and *ZONE* menu. The accuracy of this clock depends on the LTC output frequency, because the frequency of the LTC is the frequency of the clock!

Time code information: time address

Four basic operating modes are provided, accessible by the buttons *time*, *timer*, *tc* and *start*. These operating modes define the data content of the time addresses:

- *time*: Time of the internal clock.
- *timer*: Time of any timer of the MTD system, as selected at menu TIMER - TIME A-F.
- *tc*: Jam-Sync mode: time of the LTC input or free-running counter, as selected at menu LTC IN - MODE
- *start*: Free-running counter.

Time code information: binary groups

The binary groups are intended for storage and transmission of user defined data. In principle the unit uses the unspecified character set, i.e. the binary group flags BGF0, BGF1, BGF2 are set to zero. Selection at menu SET - ... - USER MOD defines the data content of the binary groups for three different kinds of data:

- fixed values, free selectable by the user;
- multiplexed data of the LTC(MTD);
- the date of the internal clock, at various formats.

Additionally the binary groups can get their data from the Jam-Sync feature.

There is a mixing up of all these subjects, so some combinations may work, some not. The following chapters will give some more detailed examples of how to set-up the unit.

2.2 Time Operating Mode

Select this operating mode for a real time or local time application. Please notice chapter "Operating with a Real Time Reference" for installation hints.

LTC output frequency

- 1st preference: If the unit works within a television system, choose genlock to a black-burst or video signal (select genlock = *bb* at menu SET - ... - LOCK and press *genlock* button). For a perfect solution the SPG should be locked to a stable real time reference - see chapter "Video and Time Code Locked to a Real Time Reference".
- 2nd preference: With a stable real time reference (stable 1pps signal) choose genlock to a 1pps signal (select genlock = *SEC* at menu SET - ... - LOCK and press *genlock* button).
- 3rd preference: With a stable external LTC signal (not a VTR LTC) choose genlock to LTC input (select genlock = *LTC* at menu SET - ... - LOCK and press *genlock* button).
- 4th preference: Press *intern* button to select the internal reference.

Internal clock, time/date handling and time address of the time code

- The data content of the time addresses is exactly the time of the internal clock.
- The internal clock get a pre-set from a built-in or external real time reference. The mode of operating with the reference time input is selected at menu REFER - MODE1 and MODE2. Time zone programming is done at submenu ZONE (select the offset and the Daylight Saving Times).

Time code information: binary groups

- As selected at menu SET - ... - USER MOD.

2.3 *Timer* Operating Mode

This operating mode enables to manipulate the time addresses of the LTC output by using an operational unit of the MTD system.

LTC output frequency

- 1st preference: If the unit works within a television system, choose genlock to a black-burst or video signal (select genlock = *bb* at menu SET - ... - LOCK and press *genlock* button).
- 2nd preference: Press *intern* button to select the internal reference.

Internal clock and time/date handling

- The internal clock get a pre-set from a built-in or external real time reference. The mode of operating with the reference time input is selected at menu REFER - MODE1 and MODE2. Time zone programming is done at submenu ZONE (select the offset and the Daylight Saving Times). Time and date are part of the multiplexed data of the binary groups (the LTC(MTD) format), thus the displays of the MTD system can decode and display time and date.

Time code information: time address

- The time addresses follow the time of a timer of the MTD system, as selected at menu TIMER - TIME A-F. There are two modes selectable: 6-digits and 8-digits mode. Please see at "Detailed menu description" for more information.

Time code information: binary groups

- Operation in the MTD system requires to have SET - ... - USER MOD. = 1 TTT selected, thus the binary groups contain multiplexed data (the LTC(MTD) format).

2.4 TC Operating Mode

Select this operating mode for a Jam-Sync application like refreshing, regenerating, synchronisation etc.

The LTC generator accepts data from the LTC input after the LTC has passed three tests: 'forward' direction must be detected, it must contain a valid time and the time addresses of two consecutive frames must be in ascending and continuous order.

Submenu LTC IN provides all adjustments regarding the Jam-Sync operating mode. The Jam-Sync can operate as a One Time Jam-Sync, as a Continuous Jam-Sync, or as Jam-Sync with Stop:

- One Time Jam-Sync: having accepted the first data of the LTC input the One Time Jam-Sync will transfer these data to the generator, then the *tc* operating mode will be switched off and the *start* operating mode will be switched on automatically. If binary groups data should be transferred and kept, then USER MODE = 0 SET should be selected (at menu SET - ... - USER MOD)!
- Continuous Jam-Sync: with this mode the generator keeps on counting if there are no LTC input (unlimited flying wheel).
- Jam-Sync with Stop: this mode forces the generator to stop after a programmed number of frames if there are no LTC input (drop-out compensation) and if the Jam-Sync is programmed to transfer time data. In case of such a stop the LTC output can completely be suppressed (Stand-By feature) or LTC can be generated having equal time addresses in each frame (Still feature).

LTC output frequency

- 1st preference: If the unit works within a television system, choose genlock to a black-burst or video signal (select genlock = *bb* at menu SET - ... - LOCK and press *genlock* button).
- 2nd preference: With a stable external LTC signal choose genlock to LTC (select genlock = *LTC* at menu SET - ... - LOCK and press *genlock* button). The LTC output gets a frequency and phase adjustment to the LTC input. With this genlock mode it can be programmed (menu LTC IN - MODE) that a data transfer from LTC input to LTC output only happens if the generator locks to the LTC input, so no Jam-Sync at jog or shuttle frequencies will be allowed.
- 3rd preference: Press *intern* button to select the internal reference.

Internal clock, time/date handling

- The internal clock get a pre-set from a built-in or external real time reference. The mode of operating with the reference time input is selected at menu REFER - MODE1 and MODE2. Time zone programming is done at submenu ZONE (select the offset and the Daylight Saving Times).
- If any time and/or date applications should be kept during the *tc* operating mode, the LTC output frequency should be locked to a stable reference, because this is the frequency of the internal clock as well. The internal clock can be programmed to get a time and date update every second (menu REFER - MODE 1), in that case the internal clock follows the reference time mostly independent from the LTC output frequency. The transfer of binary groups data from the LTC input should be switched off (menu LTC IN - MODE), so the binary groups of the LTC output contain the data as selected at menu SET - ... - USER

MOD, for example the date (different formats) or the time and date of the LTC(MTD) format for use in the MTD system.

Time code information: time address

- The time addresses depends on the mode selected at menu LTC IN - MODE: if no transfer of time data is selected (only binary groups data transfer), the time addresses will be counted as a free-running counter, just counting on from the values present before switching on the *tc* operating mode.
- If at menu LTC IN - MODE a transfer of time data is selected, the following features are available:
 - Without the offset feature: Using a frame compensation mechanism the time addresses of the LTC output correspond exactly to the time addresses of the LTC input. A break in the LTC input time will appear at the LTC output with three frames delay.
 - Offset feature: select a hours:minutes:seconds:frames offset to compensate or create a delay between LTC input and LTC output time addresses. This feature can be switched on or off.

Time code information: binary groups

- The binary groups of the LTC output depends on the mode selected at menu LTC IN - MODE: if no transfer of binary groups data is selected (only time data transfer), the binary groups contain data as selected at menu SET - ... - USER MOD.
- If at menu LTC IN - MODE a transfer of binary groups data is selected, the following features are available:
 - Direct binary groups data transfer, with a delay of one frame.
 - Cross Jam-Sync: transfer the time addresses of the LTC input to the binary groups of the LTC output. The features Offset and Stop (with drop-out compensation) then operates on the binary groups of the LTC output. The time addresses of the LTC input will exactly appear in the binary groups of the LTC output (using a frame compensation mechanism).

2.5 Start Operating Mode

Free-running counter operating mode: when this mode is initiated by the *start* button, the unit simply switches to a free-running counter mode internally.

Pressing this button during *start* operating mode and having the START function enabled (at submenu SET - ... - PARA): the time value which has last been chosen as a start value (menu SET - START) will be transferred to the time addresses of the LTC output, and the generator keeps on counting continuously from this start value on.

LTC output frequency

- 1st preference: If the unit works within a television system, choose genlock to a black-burst or video signal (select genlock = *bb* at menu SET - ... - LOCK and press *genlock* button).
- 2nd preference: With a stable external LTC signal (not a VTR LTC) choose genlock to LTC (select genlock = *LTC* at menu SET - ... - LOCK and press *genlock* button).
- 3rd preference: Press *intern* button to select the internal reference.

Internal clock, time/date handling

- The internal clock get a pre-set from a built-in or external real time reference. The mode of operating with the reference time input is selected at menu REFER - MODE1 and MODE2. Time zone programming is done at submenu ZONE (select the offset and the Daylight Saving Times).
- If any time and/or date applications should be kept during the *start* operating mode, the LTC output frequency should be locked to a stable reference, because this is the frequency of the internal clock as well. The internal clock can be programmed to get a time and date update every second (menu REFER - MODE 1), in that case the internal clock follows the reference time mostly independent from the LTC output frequency. The binary groups of the LTC output may contain time and/or date, as selected at menu SET - ... - USER MOD, for example the date (different formats) or the time and date of the LTC(MTD) format for use in the MTD system.

Time code information: time address

- Free-running counter, starts with the values selected at menu SET - START (if enable at menu SET - ... - PARA).

Time code information: binary groups

- As selected at menu SET - ... - USER MOD.

3 Detailed Menu Description

3.1 General Description

The menu lets you adjust parameters or pre-set values, or it shows test and status data. The *menu* button switches on or off the menu. With ↑ and ↓ buttons you will go to the various submenus, with the → button you reach all the items present at this submenu. Chapter 1.7 gives an overview of the menu structure. The *enter* button executes functions, starts set modes or stores settings.

Pressing the *menu* button to switch the menu off the display will return to show the time or binary groups data. Pressing this button during a set mode will quit this mode and no new setting will be stored. Same applies if the *time/user* button is pressed.

If there has been a change to any setting GM-TTT stores the new data into the non-volatile memory. The display shows "store" and no key stroke will be acknowledged during that time.

3.2 SET

| | | |
|-----|-----------|---|
| SET | SET START | Enter a start value of the time code generator. |
| | SET USER | Enter user defined data for the binary groups of the time code. |
| | SET TIME | Set the time of the internal clock. |
| | SET DATE | Set the date of the internal clock. |
| | USER MOD. | Select what kind of information should appear in the binary groups. |
| | LOCK | Select the genlock and the colour lock mode. |
| | F-RATE | Select frame rate and television system. |
| | PARA | More system parameters. |
| | FACTORY | Factory reset, all current parameters except 'user area' and 'time zone parameters' can be reset to default values. |

3.2.1 SET START: Enter a Start Value

Press the *enter* button to enable the pre-set of a start value (referred to the time address of the time code). The last pre-set value appears at the display. The values of the flashing pair of digits can be changed using the ↑ or ↓ button, the next pair can be selected using the → button. The allowed range will be 00-23 of the hours, 00-59 of the minutes and seconds, 00-23/24/29 of the frames - dependent on the frame rate. Press the *enter* button to store the values and to quit the menu.

Whenever the *start* button is pressed in the *start* operating mode and the START function is enabled (submenu SET - ... - PARA), the generator starts its free-running counter with this start value.

3.2.2 SET USER: Enter User Defined Data for the Binary Groups

Press the *enter* button to enable the pre-set of user defined data for the binary groups of the time code. The last pre-set value appears at the display. The value of the flashing digit can be changed using the \uparrow or \downarrow button, the next digit can be selected using the \rightarrow button. The allowed range will be 0-9 and A-F, i.e. a hexadecimal value. Press the *enter* button to store the values and to quit the menu.

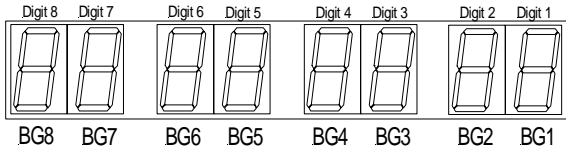

It depends on the setting of the USER MODE (at menu SET - ... - USER MOD) and - if the *tc* operating mode selected - on the setting at menu LTC IN - MODE, whether the user defined data appear at the LTC output:

tc operating mode is not selected:

- USER MODE = 0 SET: the binary groups of the time code get all the user defined data.
- USER MODE = 2 DATE: binary groups 1 to 6 are reserved for day, month and year of the internal clock. Only binary groups 7 and 8 correspond to the two most significant digits of the pre-set values.
- With all other settings of USER MODE the binary groups are reserved for other functions.

tc operating mode is selected:

- If at LTC IN - MODE any mode is selected, which transfers data into the binary groups of the time code generator, then this feature overwrites any other user defined data of the time code output.
- If only a data transfer to the time addresses has been selected, then the same applies as described at "*tc* operating mode is not selected" above.

3.2.3 SET TIME: Set the Time of the Internal Clock

Press the *enter* button to enable the pre-set of the time of the internal clock. The value of the flashing pair of digits can be changed using the \uparrow or \downarrow button, the next pair can be selected using the \rightarrow button. The allowed range will be 00-23 of the hours, 00-59 of the minutes and seconds. Press the *enter* button to transfer the values to the internal clock and to quit the menu.

- With option T or GPS IN the time of the built-in reference is set at the same time.
- Usually the time of the internal clock will be set automatically by an external reference.

3.2.4 SET DATE: Set the Date of the Internal Clock

Press the *enter* button to enable the pre-set of the date of the internal clock. The current value appears at the display, in the format day/month/year at the place of minutes/seconds/frames. The value of the flashing pair of digits can be changed using the \uparrow or \downarrow button, the next pair can be selected using the \rightarrow button. Pressing the *enter* button the unit checks the input for a valid date, then the values will be transferred to the internal clock.

- With option T or GPS IN the date of the built-in reference is set at the same time.
- Usually the date of the internal clock will be set automatically by an external reference.

3.2.5 USER MOD.: Data Content of the Binary Groups

Press the *enter* button to define the data content of the binary groups. The current selection appears at the display. Use the \uparrow or \downarrow button to step through the different items. Press the *enter* button to confirm your choice and to quit the menu.

Please notice: in the *tc* operating mode the data content of the binary groups will be overwritten, if the Jam-Sync mode includes a transfer of the binary groups.

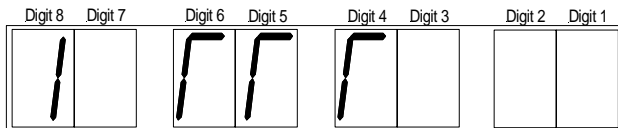

- 0 *SET* The binary groups get user defined data, see 3.2.2 SET USER.

- 1 *TTT* The binary groups get multiplexed data for use in the MTD Time-Timer-Time Code System. The specific LTC(MTD) will be generated.

- 2 *DATE* The binary groups 1 to 6 get the date of the internal clock, BCD format: day = groups 5+6 ("minutes"), month = groups 3+4 ("seconds"), year = groups 1+2 ("frames"). The year is coded with two digits. The groups 7+8 ("hours") get the user defined data, see 3.2.2 SET USER. Look at the table of the end of this chapter for a survey of the date formats.

3 *STATUS* The binary groups 1 to 6 get the date of the internal clock, same as at 2 *DATE*. The groups 7+8 ("hours") contain status information:

| Bit(s) | Group 7 ("units of hours"): | | | | | | | | |
|--------|--|-------|-------|---|---------|---|---------|---|-----------|
| 0 | = 1 if the time addresses of the time code output are synchronised to a reference time, which is locked. This bit is set in operating mode <i>time</i> only. Within the last 24 hours the internal clock must have received a pre-set from a reference time, which is locked itself. The lock status of the reference time is indicated by status information of the serial data input and is visibly indicated by the LED <i>free</i> . | | | | | | | | |
| 1+2 | = time zone of the internal clock: <table style="display: inline-table; vertical-align: middle; margin-left: 20px;"> <tr> <td style="padding-right: 10px;">bit 2</td> <td style="padding-right: 10px;">bit 1</td> </tr> <tr> <td>0</td> <td>0 = UTC</td> </tr> <tr> <td>0</td> <td>1 = CET</td> </tr> <tr> <td>1</td> <td>0 = CEST.</td> </tr> </table> | bit 2 | bit 1 | 0 | 0 = UTC | 0 | 1 = CET | 1 | 0 = CEST. |
| bit 2 | bit 1 | | | | | | | | |
| 0 | 0 = UTC | | | | | | | | |
| 0 | 1 = CET | | | | | | | | |
| 1 | 0 = CEST. | | | | | | | | |
| 3 | = 1 during announcement start/end of Daylight Savings Time, one hour before the changing occurs. | | | | | | | | |

| Bit(s) | Group 8 ("tens of hours"): |
|--------|---|
| 0 | = 1 during announcement of a leap second, one hour before the changing occurs. |
| 1 | Y2K flag: = 1, if the two digits coded year is less 98, else it is = 0. See "5 <i>DATE-2</i> " as well. |
| 2 | not used, = 0. |
| 3 | not used, = 0. |

Look at the table of the end of this chapter for a survey of the date formats.

4 *BBC* All binary groups are used for the date, with a special format according to EBU Technical Information I29-1995 (BBC format). The date is BCD-coded and assigned to the binary groups as follows:

| | | |
|-----|--------------------|----------------------------|
| BG1 | reserved | bits = 0 |
| BG2 | units of the day | 4 bits, lsb = bit 12 |
| BG3 | units of the month | 4 bits, lsb = bit 20 |
| BG4 | tens of the day | 2 bits, lsb = bit 28 |
| | tens of the month | 1 bit = bit 30, bit 31 = 0 |
| BG5 | reserved | bits = 0 |
| BG6 | units of the year | 4 bits, lsb = bit 44 |
| BG7 | reserved | bits = 0 |
| BG8 | tens of the year | 4 bits, lsb = bit 60 |

5 *DATE-2* All binary groups are used for the date of the internal clock, BCD format: day = groups 7+8 ("hours"), month = groups 5+6 ("minutes"), year = groups 1 to 4 ("seconds" and "frames"). The year is coded in four digits, valid from 1998 to 2097. The reference input of the date may have the year only with two digits, so the following rule applies: with the two digits coded year < 98 the century will be 20, else 19. After power-on the unit starts with the date 1.1.2002. Look at the table of the end of this chapter for a survey of the date formats.

- 6 *DATE-3*
- 7 *DATE-4*
- 8 *DATE-5*
- 9 *DATE-6*

There are more formats of the date selectable, similar to the selection "*2 DATE*". Please look at the table of the end of this chapter for a survey of the date formats.

A *DATE-7* Conforming to a "TVE" specification:

- The arrangement of Day, Month and Year conforms to "*8 DATE-5*".
- BG1 gets an appointment code = \$8, BG8 gets a check sum = bit-wise complement of the sum (modulo-16) of BG1 to BG7.
- Additionally the binary group flag BGF2 is set to 1.

b *OFF nn* Coding of date and a time offset, conforming to LEITCH CSD-5300 format with Auxiliary Offset. The binary groups are used for the date as described under "*4 BBC*". Additionally an offset is encoded in 30-minute increments. 6 bits in binary form are split into two 3-bit groups and are inserted into the reserved binary groups BG5 and BG7:

| | | |
|-----|----------------------|----------------------|
| BG5 | offset, 3 lower bits | 3 bits, lsb = bit 36 |
| BG7 | offset, 3 upper bits | 3 bits, lsb = bit 52 |

This allows an offset in the positive direction of up to 23 hours 30 minutes, or 47 half hour steps (101111 in 6-bits binary form). Devices decoding these bits add this offset to the time information of the time code. The date coded in the binary groups is not coupled with that offset, i.e. the date changes at 24 o'clock of the time information of the time code.

Having "b OFF" at menu USER MOD. selected, use → button to change the offset. Use *enter* button to store a new offset.

| Offset <i>nn</i> | Description |
|------------------|--|
| <i>In</i> | <p>Automatic setting of the offset such that the result of adding the offset to the time information gives the reference time, i.e. OFFS1 or OFFS2 respectively (dependent on the current time zone) of menu ZONE will be inverted and encoded:</p> <p>Reference time = UTC, GM-TTT generates a local time with DST ('Mode' parameter at menu REFER - MODE1 = u). Using the offset it is possible to compute the UTC again.</p> <p>Reference time = a local time with DST, GM-TTT generates UTC ('Mode' parameter at menu REFER - MODE1 = i). Using the offset it is possible to compute the local time again.</p> <p>Example: reference time = UTC, GM-TTT generates CET/CEST with an offset of one hour at normal time (OFFS1 = 01) and an offset of two hours at DST (OFFS2 = 02). During normal time the offset encoded at BG5 and BG7 is equal to minus one hour (= +23 hours = $46_{10} = 101110_2$), during DST the offset encoded at BG5 and BG7 is equal to minus two hours (= +22 hours = $44_{10} = 101100_2$).</p> |
| <i>00 - 47</i> | <p>Fixed offset for all times, independent from a time zone. The two-digits decimal number represents the half hour steps.</p> <p>Example: 47 = + 23 hours 30 minutes, or - 30 minutes!</p> |

- C DATE-7
- D DATE-8

There are more formats of the date selectable, similar to the selection "2 DATE". Please look at the following table for a survey of the date formats.

Table of BCD date formats:

| | BG8 7 | BG6 5 | BG4 3 | BG2 1 |
|----------|-------|-------|-------|-------|
| 2 DATE | U U | D D | M M | Y Y |
| 3 STATUS | S S | D D | M M | Y Y |
| 5 DATE-2 | D D | M M | Y Y | Y Y |
| 6 DATE-3 | Y Y | M M | D D | U U |
| 7 DATE-4 | U U | Y Y | M M | D D |
| 8 DATE-5 | U Y | Y M | M D | D U |
| 9 DATE-6 | D D | M M | Y Y | U U |
| C DATE-7 | M M | D D | Y Y | U U |
| D DATE-8 | U U | M M | D D | Y Y |

D D = day, M M = month, Y Y = year. The characters U U get the user defined data of that binary group, see 3.2.2 SET USER.

3.2.6 LOCK: Genlock and Colour Lock Mode

Press the *enter* button to display or select the genlock mode of the LTC output. The flashing field can be changed using the \uparrow or \downarrow button, the next field can be selected using the \rightarrow button. Press the *enter* button to confirm your choice and to quit the menu.

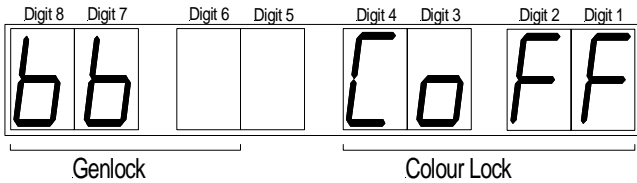

Select genlock mode:

- bb* Genlock to a black-burst or CVBS video signal.
- LTC* Genlock to a LTC source.
- SEC* Genlock to a 1pps signal.

See chapter "4 Genlock" for a detailed description of this feature.

Select colour lock mode:

- Coff* Colour lock mode switched off.
- Con* Colour lock mode switched on.

See chapter "7.1 Colour Lock" for a detailed description of this feature.

3.2.7 F-RATE: Select Frame Rate and Television System

Press the *enter* button to display or select the frame rate. Use the \uparrow or \downarrow button to change, press the *enter* button to confirm your choice and to quit the menu.

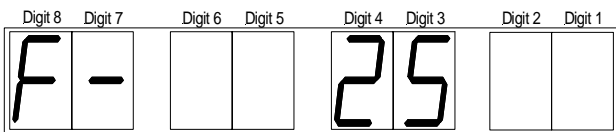

- 24 Frame rate = 24 frames per second. 24 frames exactly give one second of real time. A colour lock mode will be automatically switched off. The LED's 30 and 25 both will be off. The internal parameters regarding the video system will be kept, i.e. if the frame rate was 25 before the systems parameter will be the one of the 625/50 system; if the frame rate was 30 before the systems parameter will be the one of the 525/60 system. According to ANSI/SMPTE 12M-1995 the time code flag bits in the 24-frame system should be the one of the 30-frame system.
- 25 Frame rate = 25 frames per second, used in a 625/50 television system. 25 frames exactly give one second of real time. The LED 25 lights up. With this frame rate the unit sets internal parameters according to the 625/50 television system, concerning the VITC generator, the video/black-burst genlock and some time code flag bits.

- 30** Frame rate = 30 frames per second. 30 frames exactly give one second of real time (at genlock to internal reference). The LED 30 flashes slowly. With this frame rate the unit sets internal parameters according to the 525/60 television system, concerning the VITC generator, the video/black-burst genlock and some time code flag bits.
- 30dr** Frame rate = 30 frames with drop-frame compensation, used in a 525/60 television system. The LED 30 lights up. With this frame rate the unit sets internal parameters according to the 525/60 television system, concerning the VITC generator, the video/black-burst genlock and some time code flag bits.

3.2.8 PARA: More System Parameters

Adjust various system parameters. Press the *enter* button to display or select the genlock mode of the LTC output. The flashing field can be changed using the \uparrow or \downarrow button, the next field can be selected using the \rightarrow button. Press the *enter* button to confirm your choice and to quit the menu.

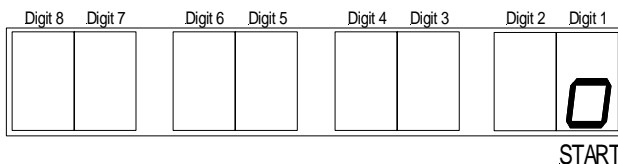

- START:** Switches on/off the START function:
- o: off, i.e. button *start* pressed during main operating mode *start* has no function.
 - A: START function activated, i.e. button *start* pressed during main operating mode *start* transfers the time value which has last been chosen as a start value (menu SET - START) to the LTC time information, and the generator keeps on counting continuously from this start value on.

3.2.9 FACTORY: Factory Reset

Force a new start of GM-TTT with all parameters set to a default setting (see chapter "Factory Settings"). After a first press at the *enter* button the display shows 'RESET =='. This mode will be skipped if now the *menu*, \uparrow , \downarrow or \rightarrow button is pressed. A further press at the *enter* button will execute the RESET.

3.3 TIMER

This submenu handles some features in the case that the GM-TTT works as a central unit of the Alpermann + Velte MTD Time-Timer-Time Code system. *Alpermann + Velte* developed the Multiple Time Display System (MTD). This system supplies the video studio with time information as local time, date, time code, VTR time code, stop timers etc. A MTD system consists of a central generator, digital displays and/or index clocks as well as operational units. The central generator generates a specific LTC format which is referred to as LTC(MTD) in this document. The LTC(MTD) transfers data to all digital displays and includes the time information mentioned above. The operational units communicate with the central generator via a RS485 bus and are connected to the LTC(MTD)/RS485 connector.

| | | |
|-------|----------|--|
| TIMER | TIME A-F | Select a MTD timer (A ... F or Main Timer 1) and timer mode for the <i>timer</i> operating mode. |
| | U STORE | All current settings including the parameters set from a MTD operational unit can be stored to an 'user area'. |
| | U LOAD | The parameters stored in an 'user area' can be loaded, the unit will be forced to start anew. |
| | U RESET | The parameters stored in an 'user area' can be reset to default values. |
| | A (data) | Display timer A (test purpose only). |
| | B (data) | Display timer B (test purpose only). |
| | C (data) | Display timer C (test purpose only). |
| | D (data) | Display timer D (test purpose only). |
| | E (data) | Display timer E (test purpose only). |
| | F (data) | Display timer F (test purpose only). |

3.3.1 TIME A-F: Installation of the *Timer* Operating Mode

Press the *enter* button to display or change the current parameters of the *timer* operating mode. The flashing field can be changed using the ↑ or ↓ button, the next field can be selected using the → button. Press the *enter* button to confirm your choice and to quit the menu.

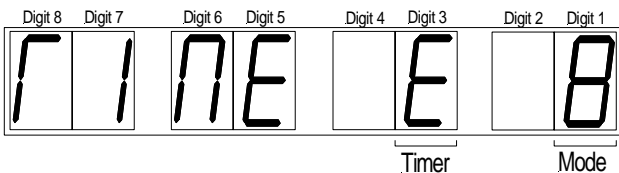

Select timer:

In the *timer* operating mode the time addresses of the time code follow the time of a MTD timer.

- A ... F Select timer A, B, C, D, E or F.
- H Select the 1st main timer.

Select mode:

This installation selects between two kinds of handling the time of an down-counting timer. It influences the time addresses only, not the data of the LTC(MTD).

- 6 6-digits operating mode: the time addresses of the LTC output will be prepared for a LTC reader display, which only displays hours/minutes/seconds. It is supposed, that the LTC reader adds one frame to compensate for delay as it is a recommended practice. In a 6-digits display the down-counting timer reaches zero as soon as the seconds switches from 1 to 0. Compared with the 8-digits operating mode the time addresses get a one second minus one frame addition.

| Down-counting hours:minutes:seconds(:frames) | Time addresses, 6-digit mode | LTC display, 8 digits | LTC display, 6 digits |
|---|---------------------------------|--------------------------|--------------------------|
| 00:00:02 (:01) | 00:00:02:00 | 00:00:02:01 | 00:00:02 |
| 00:00:02 (:00) | 00:00:01:24 | 00:00:02:00 | 00:00:02 |
| 00:00:01 (:24) | 00:00:01:23 | 00:00:01:24 | 00:00:01 |
| etc. | | | |
| 00:00:01 (:01) | 00:00:01:00 | 00:00:01:01 | 00:00:01 |
| 00:00:01 (:00) | 00:00:00:24 | 00:00:01:00 | 00:00:01 |
| 00:00:00 (end) | 00:00:00:23 | 00:00:00:24 | 00:00:00 |

- 8 8-digits operating mode: the time addresses of the LTC output will be prepared for a LTC reader display, which displays the frames as well. It is supposed, that the LTC reader adds one frame to compensate for delay as it is a recommended practice. In a 8-digits display the down-counting timer reaches zero if even the frames have 00. If the 8-digits mode is selected but a 6-digits display used, the time at the display appears to be one second in advance.

| Down-counting hours:minutes:seconds(:frames) | Time addresses, 8-digit mode | LTC display 8 digits | LTC display 6 digits |
|---|---------------------------------|-------------------------|-------------------------|
| 00:00:02 (:01) | 00:00:01:01 | 00:00:01:02 | 00:00:01 |
| 00:00:02 (:00) | 00:00:01:00 | 00:00:01:01 | 00:00:01 |
| 00:00:01 (:24) | 00:00:00:24 | 00:00:01:00 | 00:00:01 |
| 00:00:01 (:23) | 00:00:00:23 | 00:00:00:24 | 00:00:00 |
| etc. | | | |
| 00:00:01 (:01) | 00:00:00:01 | 00:00:00:02 | 00:00:00 |
| 00:00:01 (:00) | 00:00:00:00 | 00:00:00:01 | 00:00:00 |
| 00:00:00 (end) | 23:59:59:24 | 00:00:00:00 | 00:00:00 |

3.3.2 U STORE / U LOAD / U RESET

"U" denotes a user area. It is a non-volatile memory, in which a whole set-up of GM-TTT can be stored separately. See chapter "Factory Settings" for more details.

Press the *enter* button to execute the selected function:

U STORE This function stores the parameters of the current set-up to the user area, this includes the parameters of the MTD system transferred from an operational unit - except the time zone parameters of timers A - F (see chapter "Factory Settings" for details). During this process *STORE* is displayed, at the end *U STORE* will be displayed again. The storing process has no influence to the running time code operating mode.

U LOAD This function recalls the set-up of the user area, and it forces a re-start of GM-TTT!

U RESET This function resets the parameters of the user area. During this process *STORE* is displayed, at the end *U RESET* will be displayed again. The storing process has no influence to the running time code operating mode.

3.3.3 A ... F: Display Timer A ... F

Using the → button you can bring the current values of timer A ... F to the display. This is for test purposes only. The values may be different from what can be seen at a MTD display.

3.4 LTC

| | | |
|-----|----------|---|
| LTC | OUT | Select the LTC output level. |
| | POLARITY | Select the use of the polarity bit. |
| | 1 (data) | Display the six time code flag bits of the LTC generator. |

3.4.1 OUT: LTC Output Level

Press the *enter* button to display or select the LTC output amplitude. Use the \uparrow or \downarrow button to change, press the *enter* button to confirm your choice and to quit the menu.

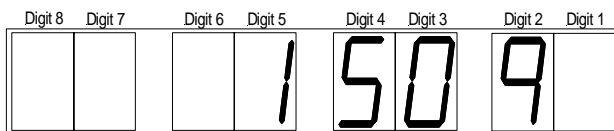

35 ... 2983 Display shows the peak-to-peak value in [mV], measured at the balanced signal (between pins 1-2 or 1-3) driving a resistive load of 1 k Ω . The selectable range is 35 mV to 2983 mV.

3.4.2 POLARITY: Select the Use of the Polarity Bit

Press the *enter* button to display or change the mode of using the polarity correction bit of the LTC output. Use the \uparrow or \downarrow button to change, press the *enter* button to confirm your choice and to quit the menu.

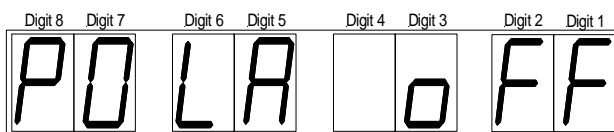

POLA off The polarity correction bit is not used and will be set to zero.

POLA on The polarity of the synchronisation word of the LTC output will be stabilised. The polarity correction bit is put in a state, so that every 80-bit word contains an even number of logical zeros. The polarity correction bit is bit no. 27 in the 525/60 system, no. 59 in the 625/50 system.

3.4.3 1: Display the LTC Flag Bits

The display immediately indicates the flag bits of the LTC output. Each flag bit may have the value 0 or 1.

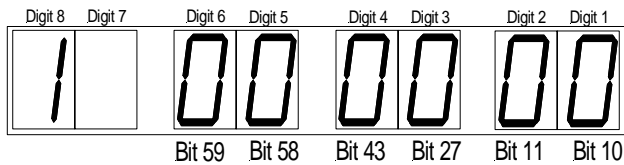

The definition of the flag bits according to ANSI/SMPTE 12M-1995:

| bit number | frame rate = 30 | frame rate = 25 | frame rate = 24 |
|------------|-------------------|-------------------|-------------------|
| 10 | drop flag | - | - |
| 11 | colour flag | colour flag | - |
| 27 | polarity | binary group BGF0 | polarity |
| 43 | binary group BGF0 | binary group BGF2 | binary group BGF0 |
| 58 | binary group BGF1 | binary group BGF1 | binary group BGF1 |
| 59 | binary group BGF2 | polarity | binary group BGF2 |

3.5 VITC

When the VITC module is installed, the settings of the VITC generator may be displayed and modified by using the *enter* button. The flashing field can be changed using the \uparrow or \downarrow button, the next field can be selected using the \rightarrow button. Press the *enter* button to confirm your choice and to quit the menu.

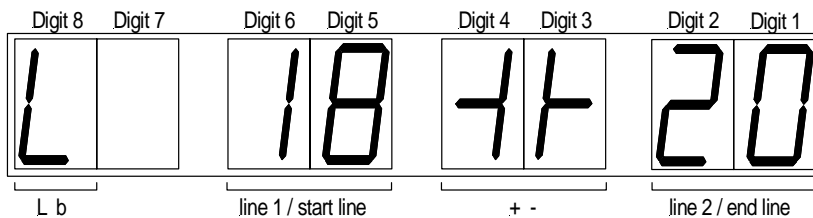

Line or block mode setting:

| | |
|-------------------|---|
| Digits 8, 4 and 3 | |
| <i>L +</i> | Line mode, i.e. two lines may be selected at maximum, line 1 being \leq line 2. If the two lines are equal, VITC is only generated in one line. |
| <i>b --</i> | Block mode, i.e. a coherent line block is selected, which is defined by start line and end line. |

Line adjustment:

Line 1 or start line is indicated by the digits 5-6, line 2 or end line in the digits 1-2. The range of values of the lines is 6 - 32. The standard ANSI/SMPTE 12M-1995 specifies a line range of 6-22 for television system 625/50 (PAL, frame rate = 25) or 10-20 for television system 525/60 (NTSC, frame rate = 30Drop), respectively.

3.6 STATUS

This display indicates some internal status information:

1 Internal registers:

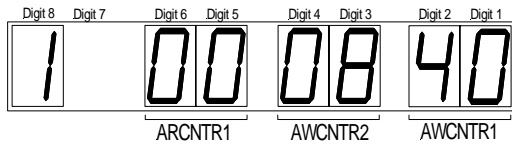

2 Hardware signals and CPU efficiency:

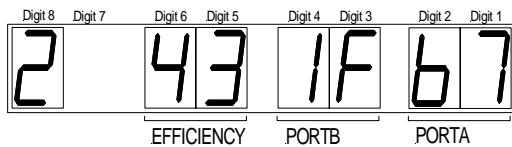

3 Current programming of the internal crystal oscillator reference. A 6-digit hexadecimal value supplying the period of the free-run frequency in [ns], when converted into the decimal system and multiplied by 125.

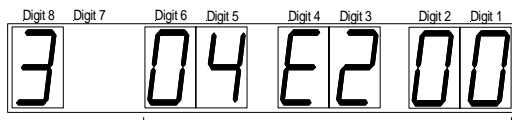

4 6-digit error counter (BCD): Error detected in the external synchronisation source. Pushing the *genlock* button will reset this counter to 0.

5 6-digit error counter (BCD): Failure detected in the external synchronisation source. Pushing the *genlock* button will reset this counter to 0.

6 6-digit error counter (BCD): Interference detected in the external synchronisation source. Pushing the *genlock* button will reset this counter to 0.

7 Internal registers:

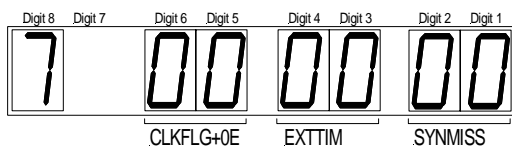

8 Internal registers:

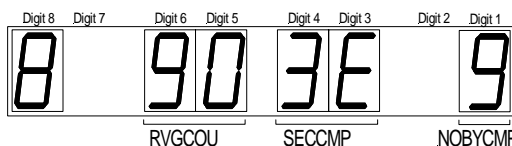

3.7 TEST

This display permits to indicate some measurement results:

- 1 Time difference between the internal and external sync signals. The digits 8 and 7 specify the milliseconds, the example below indicates the value 39.999812 ms. It is accurate to ± 125 ns.

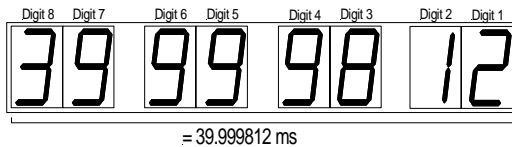

- 2 Period of the external sync signal: Video or Black-Burst, respectively, or LTC signal. The digits 8 and 7 indicate the milliseconds, the example below indicates the value 39.999812 ms. It is accurate to ± 125 ns.

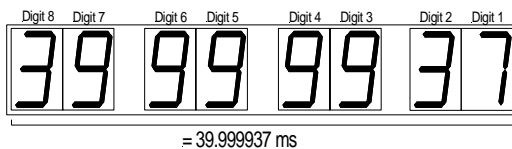

- 3 Time difference between the seconds pulse and the V1sync signal. The digits 8 and 7 specify the milliseconds, the example below indicates the value 39.999812 ms. It is accurate to ± 125 ns.

The digit 1 specifies the colour sequence of the video signal at the moment of the seconds pulse at seconds 00, 04, 08 ... by using an index. The index = 0 specifies the fields 1/2, 1 = 3/4, 2 = 5/6, 3 = 7/8. If the time code is generated with colour framing in the *time* operating mode, the time information in the time code may be corrected by some frames compared to the reference time, depending on the colour sequence of the video signal. In the 625/50 system, no correction is performed, if digit 1 indicates 3. This also refers to the 525/60 system, when digit 1 indicates 0. A diagram in the chapter entitled "Real Time Coupling of Time Code and Video" further explains this situation.

If no colour framing is selected, digit 1 remains empty.

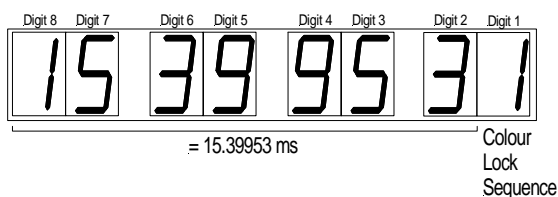

3.8 REFERENCE

This submenu refers to operation using a reference time.

MODE 1 and MODE 2 permit to define the essential parameters which are relevant for the automatic setting of the internal clock and for time zone operation. The remaining functions selected with the → button show the status data.

| | | |
|-------|----------|--|
| REFER | MODE 1 | Automatic setting and DST mode of the internal clock. |
| | MODE 2 | Time for automatic setting of the internal clock. |
| | 1 (data) | Indication of the time of the reference time. |
| | 2 (data) | Indication of the date of the reference time. |
| | 3 (data) | The last time, when the data of the reference time showed the "lock" status. |
| | 4 (data) | The last date, when the data of the reference time showed the "lock" status. |
| | 5 (data) | Offset between the reference time and the internal clock. |
| | 6 (data) | Status information resulting from the data of the reference time. |

3.8.1 MODE 1: Automatic Setting and DST Mode of the Internal Clock

Press the *enter* button to display or change the current parameters. The flashing field can be changed using the ↑ or ↓ button, the next field can be selected using the → button. Press the *enter* button to confirm your choice and to quit the menu.

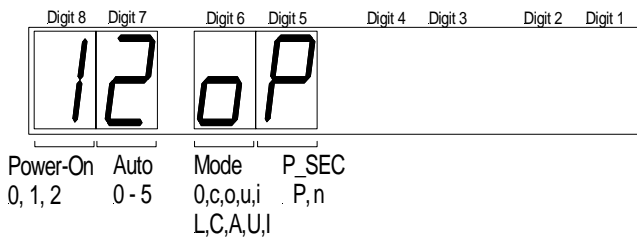

Power-On: Setting of the internal clock after power-on

- 0 The internal clock is not set directly after power-on.
- 1 The internal clock is set directly after power-on, independent of the "lock" status of the reference time, i.e. eventually also by using a non-sync clock of a DCF77 or GPS receiver.
- 2 After power-on the internal clock is only set, if the "lock" status of the reference time is indicated. If the *time* operating mode is selected and no "lock" status is indicated within a 15 minutes period, this pre-set option is deactivated.

Auto: Automatic setting of the internal clock during normal operation

- 0* No automatic setting - except those selected in the *Mode* setting.
- 1* Every second.
- 2* Once per day at the selected hour (see MODE 2).
- 3* Once per week at the selected hour (see MODE 2).
- 4* Once per month at the selected hour (see MODE 2).
- 5* Once per year at the selected hour (see MODE 2).

For selection 2 ... 5, the additional "lock" condition has to be observed (see MODE 2).

Mode: Leap Second and DST (Daylight Saving Time) mode of the internal clock

If an *additional* setting of the internal clock by the reference time in case of "real" time jumps (DST switchover or leap seconds) is selected, this setting is only performed, if the time jump was announced by the data of the reference time. Any details are described in the chapter entitled "Time Transfer During Normal Operation and Time Jumps".

| Mode | Description | Automatic DST switching of the internal clock |
|----------|--|---|
| <i>0</i> | No additional setting of the internal clock during a DST switchover of the reference time or a leap second. | Off |
| <i>c</i> | Additional setting of the internal clock during a DST switchover of the reference time, but not during a leap second. | Off |
| <i>o</i> | Additional setting of the internal clock during a DST switchover of the reference time, but not during a leap second. | On |
| <i>u</i> | The reference time is considered as UTC or as a time zone without a Daylight Saving Time, while the time zone of the internal clock has a DST. No additional setting during a leap second. | On |
| <i>i</i> | The reference time has a DST, while the time zone of the internal clock is UTC or a time zone without a DST. No additional setting during a leap second. | Off |
| <i>L</i> | Additional setting of the internal clock during a leap second, no additional setting of the internal clock during a DST switchover of the reference time. | Off |
| <i>C</i> | As for " <i>c</i> ", but additional setting of the internal clock during a leap second. | Off |
| <i>A</i> | As for " <i>o</i> ", but additional setting of the internal clock during a leap second. | On |
| <i>U</i> | As for " <i>u</i> ", but additional setting of the internal clock during a leap second. | On |
| <i>I</i> | As for " <i>i</i> ", but additional setting of the internal clock during a leap second. | Off |

P_SEC: Reference edge of the seconds pulse

- P* The positive (rising) edge is the reference.
- n* The negative (falling) edge is the reference.

3.8.2 MODE 2: Time for Automatic Setting of the Internal Clock

The internal clock can be automatically set in periodical intervals. As soon as the reference time \pm the current offset has reached the programmed time, the internal clock is set to this time. Therefore the local time zone should be respected, when selecting the moment of time.

Press the *enter* button to display or change the current parameters. The flashing field can be changed using the \uparrow or \downarrow button, the next field can be selected using the \rightarrow button. Press the *enter* button to confirm your choice and to quit the menu.

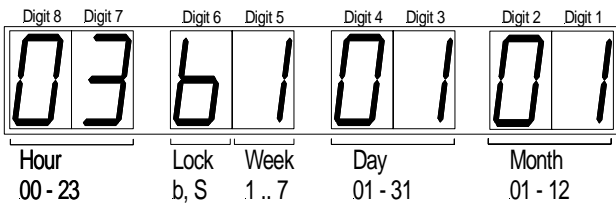

Hour: Selection of the hour

00 - 23 Range 00 - 23. This hour is taken into consideration, when *Auto* = 2, 3, 4 or 5 is selected at menu REFER - MODE 1, i.e. once per day or week or month or year.

Lock: Take the "lock" status of the reference time into account

- b* The internal clock is set at the pre-set time, independent of the "lock" status of the reference time, i.e. eventually also by a non-sync clock of the DCF77 or GPS receiver. In this case the setting is performed during the first two seconds of the selected hour.
- S* The internal clock is only set at the pre-set time, when the "lock" status of the reference time is indicated. If no "lock" status is indicated during the whole selected hour, the internal clock is not set.

Week: Selection of the day of the week

1 - 7 Range 1 - 7, 1 = Monday. The day of the week is taken into consideration, if *Auto* = 3 is selected at menu REFER - MODE 1, i.e. once per week at the selected hour of the selected day of the week.

Day: Day of the month

01 - 31 Range 01 - 31. This day is taken into account, if *Auto* = 4 or 5 is selected at menu REFER - MODE 1, i.e. once per month at the selected hour of the selected day or once per year, respectively.

Month: Selection of the month

01 - 12 Range 01 - 12. The month is taken into consideration, if *Auto* = 5 is selected at menu REFER - MODE 1, i.e. once per year at the selected hour of the selected date.

3.8.3 1 ... 6: Status Data of the Reference Time

The → button permits to switch different status messages referring to the reference time to the display for test purposes.

- 1 Reference time ± current offset. This permits to check e.g. the data communication. If the display remains empty, no valid data are received.
- 2 Date of the reference time (the current offset is taken into account), e.g. for testing the data communication. If the display remains empty, no valid data are received.
- 3 Display of the last time, when the data of the reference time indicated the "lock" status. If "lock" is currently indicated, the displayed time counts upward. If this time is frozen, the receiver has not been in the "lock" status since that time. If the time value permanently shows 00:00:00, no "lock" status has been indicated since the power-on of the GM-TTT, but the status display 4 can indicate a date. If the display remains empty, no "lock" status has been indicated since the last RESET of the GM-TTT.
- 4 Display of the last date, when the data of the reference time indicated the "lock" status. The date is stored in a non-volatile memory, so that the quality of the reference time may even be checked if in the meantime GM-TTT has been switched off. If the display remains empty, no "lock" status has yet been indicated since the last RESET of the GM-TTT.
- 5 Display of the difference: reference time minus time of the internal clock in 6 digits (minutes:seconds:frames, eventually with a minus sign). If the difference is more than one hour, the display will indicate FF:FF:FF.
- 6 Display of the status data included in the serially received data.

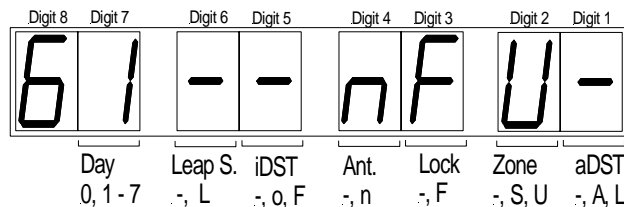

- Day* 1 - 7: Display of the current day of the week, 1 = Monday.
0: The reference time does not supply any information on the day of the week.
- Leap S.* Leap second:
L: The announcement of a leap second was internally accepted by the data of the reference time, any details are described in the chapter entitled "Time Transfer During Normal Operation and Time Jumps".
-: no internal announcement of a leap second.
- iDST* DST switchover:
F: The announcement of a DST switchover was internally accepted, any details are described in the chapter entitled "Time Transfer During Normal Operation and Time Jumps".
o: The announcement of a DST switchover was internally accepted, any details are described in the chapter entitled "Time Transfer During Normal Operation and Time Jumps".
-: No internal announcement of a switchover.

- Ant.* Antenna signal:
-: the GPS/DCF77 receiver has received a signal.
n: the GPS/DCF77 receiver is not receiving a signal.
- Lock* "Lock" status:
-: the reference time is in-sync.
F: the reference time is in free-run.
- Zone* Time zone of the reference time:
-: CET.
S: CEST.
U: UTC.
- aDST* Announcement of a time switchover of the reference time:
A: a DST switchover is announced during the hour before the switchover.
L: a leap second is announced during the hour before the switchover.
-: no time switchover is announced.

3.9 SERIAL

The settings of this submenu are provided for an optional remote control of the GM-TTT. The standard unit is equipped with a RS485 serial interface with fixed format and protocol.

| | | |
|---------------|-----------------|---|
| SERIAL | FORMAT | Select the baud rate and format of the serial interface (option). |
| | PROTOCOL | Select the remote control protocol (option). |

3.9.1 FORMAT: Select the Baud Rate and Format of the Serial Interface

Press the *enter* button to display or change the current parameters. The flashing field can be changed using the \uparrow or \downarrow button, the next field can be selected using the \rightarrow button. Press the *enter* button to confirm your choice and to quit the menu.

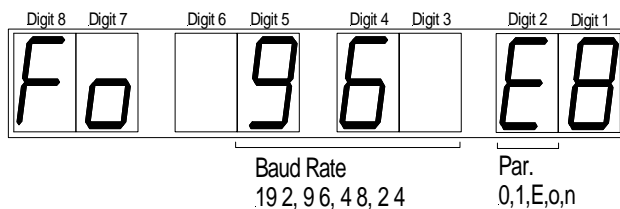

Baud rate

- 192 19 200 bps.
- 96 9 600 bps.
- 48 4 800 bps.
- 24 2 400 bps.

Parity

- 0 The parity bit is fixed to 0.
- 1 The parity bit is fixed to 1.
- E Even parity.
- o Odd parity.
- n No parity bit.

Digit 1 shows the number of data bits (= 8, fixed setting).

The number of stop bits is fixed = 1.

3.9.2 PROTOCOL: Select the Remote Control Protocol

This function is optional and not used in the standard version. The standard protocol used for option 2 (RS232) or option 4 (RS422) is described in the chapter entitled "Serial Remote Control Interface".

3.10 LTC IN

Option L must be installed. This submenu permits to make the settings for the *tc* operating mode (Jam-Sync applications) and for the VTR LTC (if LTC(MTD) is generated). The data of the readout LTC may be switched to the display for test purposes.

| | | |
|--------|----------|---|
| LTC IN | MODE | Settings for the operation mode using external LTC. |
| | OFFSET | Offset programming for the time information. |
| | 1 (data) | Indication of the readout LTC time. |
| | 2 (data) | Indication of the binary groups of the readout LTC. |
| | 3 (data) | Indication of the current six flag bits of the readout LTC. |

3.10.1 MODE: Settings for the Operation Mode Using External LTC

Press the *enter* button to display or change the current parameters. The flashing field can be changed using the \uparrow or \downarrow button, the next field can be selected using the \rightarrow button. Press the *enter* button to confirm your choice and to quit the menu.

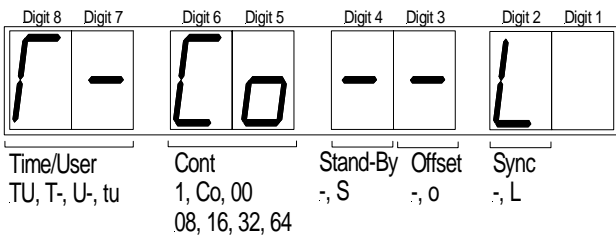

Time/User: Adopt the time information and/or binary groups (*tc* operating mode)

- T U* Time and binary groups.
- T -* Only time.
- U* Only binary groups.
- t u* The readout LTC time is transferred to the binary groups of the generated time code (cross Jam-Sync).

Cont: Set continuous transfer or transfer with stop (*tc* operating mode)

- 1* 1x Jam-Sync: The data are transferred once, then the *tc* operating mode is automatically deactivated, and the *start* operating mode is switched on.
- Co* Continuous Jam-Sync: In this mode, the generator continues to count by itself, if no LTC can be read out (unlimited flywheel).
- 00* Jam-Sync with stop: If no LTC is read out and time transfer is selected, the generator will stop.
- 08 ... 64* Jam-Sync with "flywheel": If no LTC is read out and time transfer is selected, the generator will continue to count by a specified number of frames (adjustable flywheel), before it stops.

Standby: Behaviour of the LTC output during stop (*tc* operating mode)

- no standby, i.e. a LTC with permanently identical data is generated during stop.
- S Standby, i.e. the LTC output is muted during stop.

Offset: Time information of the read-out LTC with offset addition

- no offset, i.e. this function is not active.
- o The offset is activated, i.e. the pre-set offset is added before adopting the read-out time. The offset acts upon the *tc* operating_mode as well as upon the transfer of the VTR LTC into the LTC(MTD).

Sync: Data transfer only after genlocking to the LTC has been performed (*tc* operating mode)

- The function is deactivated.
- L The function is active, if the generator shall be synchronised to the external LTC (genlock = *LTC*). The readout values shall only be adopted by the generator, if the read-out LTC does not exceed the limits of the frequency tolerance specified for genlocking.

3.10.2 OFFSET: Offset Programming for the Time Information

Display and adjustment of a time offset. If the offset function is activated (LTC IN - MODE menu), the time information of the readout LTC is added to the offset and then made available for the Jam-Sync application or the VTR LTC. A negative offset is generated by taking into account the 24-hours carryover, i.e. a value of minus one frame is e.g. calculated by using an offset of 23:59:59:24 (with frame rate = 25).

Press the *enter* button to display or change the current setting. The flashing pair of digits can be changed using the \uparrow or \downarrow button, the next pair of digits can be selected using the \rightarrow button. The range of values 00-23 is for the hours, 00-59 for the minutes and seconds and 00-23/24/29 for the frames, according to the selected frame rate. The frame rate of the readout LTC should correspond to the frame rate of the generated LTC. Press the *enter* button to confirm your choice and to quit the menu.

3.10.3 1 ... 3: Status Data of the Readout LTC

Press the \rightarrow button to switch different status data of the read-out LTC to the display for test purposes.

- 1 Display of hours:minutes:seconds:frames = time information of the readout LTC. The displayed time does not include any frame compensation or calculated offset.
- 2 Indication of the binary groups of the readout LTC.
- 3 Indication of the flag bits of the readout LTC and of an index (Frequ) for the detected frequency: 0 = stop, 1 = slow, 2 = normal, 3 = fast.

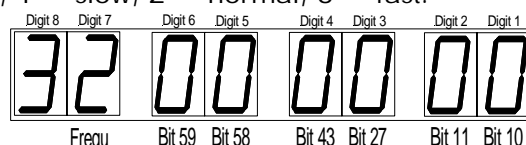

3.11 GPI

Option G must be installed. The settings of this submenu are used for operation with a relay which may be triggered at a programmed time. A "GPI" (General Purpose Interface) is a switching relay. The contacts between COM1 and NO1 are normally open, or closed when triggered, and normally closed between COM1 and NC1, or open when triggered, respectively. Switching is performed pulse-like after triggering. The pulse, i.e. trigger duration is adjustable between about 64 ms - 1.28 s (+0 / -20 ms). Triggering is performed, when the GPI is active and a pre-set comparative time information value is detected by the LTC generator or one of the timer times out of A, B, C, D, E or F.

| | | |
|-----|-----------------|---|
| GPI | <u>SET TIME</u> | Pre-set the comparative time value for GPI relay switching. |
| | <u>SET MODE</u> | Set the GPI mode. |

3.11.1 SET TIME: Pre-set the Comparative Time Value for Relay Switching

Press the *enter* button to display or change the current setting. The flashing pair of digits can be changed using the \uparrow or \downarrow button, the next pair of digits can be selected using the \rightarrow button. The range of values 00-23 is for the hours, 00-59 for the minutes and seconds. The frames are assumed to be 00. Press the *enter* button to confirm your choice and to quit the menu.

3.11.2 SET MODE: Set the GPI Mode

Press the *enter* button to display or change the current parameters. The flashing field can be changed using the \uparrow or \downarrow button, the next field can be selected using the \rightarrow button. Press the *enter* button to confirm your choice and to quit the menu.

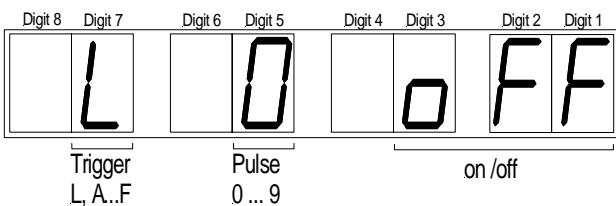

Trigger

L Trigger using the time information of the generated LTC.
A (B, C, D, E, F) Trigger using timer time A or B or C or D or E or F.

Pulse

0... 9 Set the trigger pulse duration: 0 = 128 ms, 1 = 256 ms, ..., 9 = 1280 ms (accuracy: +0 ms, -64 ms).

on/off

off Function not active.
on Function active.

3.12 ZONE

The local time zone of the internal clock is defined by the following parameters: Time offset with respect to the reference time during normal time or Daylight Saving Time, and moments of time of the switchover from normal time to DST and vice versa.

| | | |
|------|--------------|---|
| ZONE | OFFS 1 | Time zone offset during normal time. |
| | OFFS 2 | Time zone offset during Daylight Saving Time (DST). |
| | DST on | Program the beginning of the DST. |
| | DST off | Program the end of the DST. |
| | (DST period) | Indicate beginning and end of DST of the current year. |
| | RESET A-F | Reset the parameters of the time zones for the timer A - F. |

By using the parameters "DST on" and "DST off", the automatic time zone system of the internal clock calculates the switchover times. The calculation is carried out by the GM-TTT whenever the year or the parameters are changing. The result can be checked in the "DST period" menu line. Hour = 00 is not possible. If there is a switchover at 00 o'clock (which never happened until now), hour = 24 of the previous day should be selected. But principally the GM-TTT will not reset the current date, even not during a time switchover. OFFSET 1, OFFSET 2 and the difference must make a sense. Example for an entry which does not make any sense: OFFSET 1 = +02 and OFFSET 2 = -02, in this case the difference would be = -04 during switchover to Daylight Saving Time! If the switchover occurs at 03 o'clock, the GM-TTT will switch to 23 o'clock of the same day!

Examples for input (reference time) and output (time zone) with different operating modes:

| Refer-ence input | Time zone output and automatic switchover | 'Mode' parameter at menu REFER-MODE1 | Offset 1 Offset 2 |
|------------------|---|--------------------------------------|---|
| without DST | without DST, no automatic switchover | 0 | Offset 1 |
| without DST | with DST, with automatic switchover | u, U | internal clock at normal time: Offset 1 internal clock at DST: Offset 2 |
| with DST | without DST, without automatic switchover | i, I | Reference at normal time: Offset 1, Reference at DST: Offset 2. The switchover parameters must be identical with the switchover times of the reference. |
| with DST | with DST, without automatic switchover | 0, c, C | Offset 1 |
| with DST | with DST, with automatic switchover | o, A | Offset 1 (*1) |

(*1) Only offset 1 is added/subtracted, if the internal clock is set by the reference time. However, the correct entry of offset 2 is relevant in case of a DST switchover, because there is a time jump equal to the difference of offset 1 - offset 2. Example: Time zone output = reference = CET (Central European Time)/CEST: set offset 1 = 0 and offset 2 = 1!

3.12.1 OFFS 1: Time Zone Offset During Normal Time

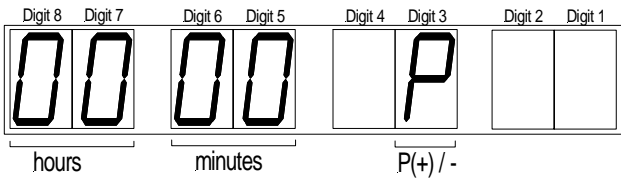

Hours, minutes and the sign may be pre-set for the offset. The entry range is between -14:59 and +14:59. The sign is indicated by P (+) or -. During normal time (no Daylight Saving Time), the value of offset 1 is added to or subtracted from the reference time. Press the *enter* button to display or change the current programming. The flashing field can be changed using the \uparrow or \downarrow button, the next field can be selected using the \rightarrow button. Press the *enter* button to confirm your choice and to quit the menu.

3.12.2 OFFS 2: Time Zone Offset During Daylight Saving Time (DST)

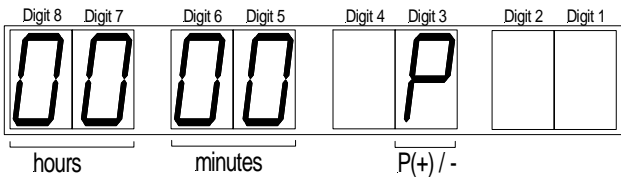

Hours, minutes and the sign may be pre-set for the offset. The entry range is between -14:59 and +14:59. The sign is indicated by P (+) or -. During Daylight Saving Time, the value of offset 2 is added to or subtracted from the reference time. Press the *enter* button to display or change the current programming. The flashing field can be changed using the \uparrow or \downarrow button, the next field can be selected using the \rightarrow button. Press the *enter* button to confirm your choice and to quit the menu.

3.12.3 DST on: Program the Beginning of the Daylight Saving Time

Press the *enter* button to display or change the current programming. The flashing field can be changed using the \uparrow or \downarrow button, the next field can be selected using the \rightarrow button. Press the *enter* button to confirm your choice and to quit the menu.

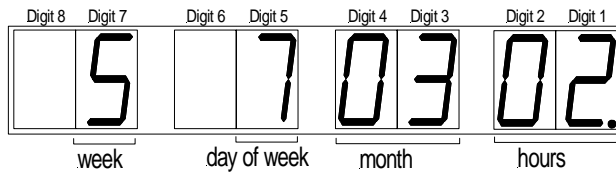

hours Hour of switchover, entry range 01 - 24.

month Month, entry range 01 - 12.

day of week Day of the week, 1 = Monday to 7 = Sunday.

week 1 - 5: switchover at the 1st, 2nd, ..., 5th (= last) day-of-week in that month.

Example: With the shown setting, the beginning of the DST is always performed on the last Sunday of March at 02 o'clock. The time always refers to the current time (of the current time zone) of the internal clock.

The decimal point of digit 1 lights up during the DST period of the internal clock.

3.12.4 DST off: Program the End of the Daylight Saving Time

Press the *enter* button to display or change the current programming. The flashing field can be changed using the \uparrow or \downarrow button, the next field can be selected using the \rightarrow button. Press the *enter* button to confirm your choice and to quit the menu.

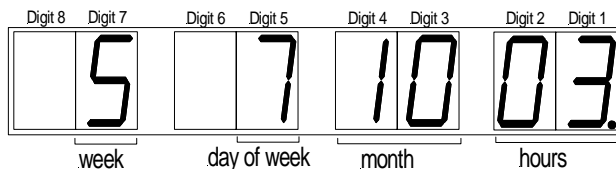

hours Hour of switchover, entry range 01 - 24.

month Month, entry range 01 - 12.

day of week Day of the week, 1 = Monday to 7 = Sunday.

week 1 - 5: switchover at the 1st, 2nd, ..., 5th (= last) day-of-week in that month.

Example: With the shown setting, the end of the DST is always performed on the last Sunday of October at 03 o'clock. The time always refers to the current time (of the current time zone) of the internal clock.

The decimal point of digit 1 lights up during the DST period of the internal clock.

3.12.5 DST Period: Indicate Beginning and End of DST of the Current Year

This display indicates the calculated date of the switchover times of the current year. It permits to check the settings after programming the start and end of Daylight Saving Time.

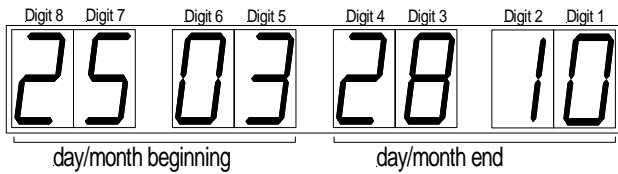

In this example: DST starts on March 25, DST ends on October 28.

3.12.6 RESET A - F: Reset the Parameters of the Time Zones for Timer A - F

Beside others, the A, B, C, D, E and F timers of the MTD Time-Timer-Time Code System may be used for a time zone application. The parameters of the time zone correspond to the parameters described in this ZONE submenu. However, they are set by using an operational unit of the MTD system. Pressing the *enter* button resets all time zone parameters to their standard values (please also refer to the chapter "Factory Settings"). The current operating mode of the A - F timers remains unchanged during this process.

4 Genlock

4.1 Genlock to a Black-Burst or Video Signal

- Connect a black-burst or CVBS video signal to BNC VIDEO/BB.
- At menu SET - ... - LOCK select *bb* and press *enter* button.
- Press *genlock* button.

The LED *genlock* lights up if genlock is operating normally. The LED flashes if the genlock signal is disturbed and the internal reference is currently selected. If the genlock signal returns to be ok the LED will light up again. The LTC output gets a frequency and phase adjustment to this genlock source. The first transition of bit 0 of each frame occurs at line 5 in a 525/60 television system and at line 2 in a 625/50 television system.

GM-TTT permanently measures the timing of the genlock source. If the frequency does not fall within the valid range, the unit switches to internal reference. For example at frame rate = 25 the unit does not accept a 525/60 television signal. Furthermore the unit adjusts its internal reference to the genlock frequency, so in case of a failure the LTC output stays at the last frequency and no disturbance of the output signal occurs. The current programming of the internal reference is displayed at menu STATUS - ... - 3.

GM-TTT permanently supervises the genlock source. An error counter increments in case of any faults, this counter is displayed at menu STATUS - ... - 4. Another error counter increments in case of a failure, this counter is displayed at menu STATUS - ... - 5. Another error counter increments in case of a disturbance, this counter is displayed at menu STATUS - ... - 6. The error counters get an update each frame. Each time the *genlock* button is pressed the error counters get a reset to zero.

4.2 Genlock to a LTC Source

- Connect a LTC signal to XLR3F LTC IN.
- At menu SET - ... - LOCK select *LTC* and press *enter* button.
- Press *genlock* button.

The LED *genlock* lights up if genlock is operating normally. The LED flashes if the genlock signal is disturbed and the internal reference is currently selected. If the genlock signal returns to be ok the LED will light up again. The LTC output gets a frequency and phase adjustment to this genlock source. Within a ½ bit accuracy the phase of the output corresponds to the input.

GM-TTT permanently measures the timing of the LTC source. If the frequency does not fall within the specified range (see chapter "Connections at the Rear and Technical Data"), the unit switches to internal reference. Furthermore the unit adjusts its internal reference to the LTC source, so in case of a failure the LTC output stays at the last frequency and no disturbance of the output signal occurs. The current programming of the internal reference is displayed at menu STATUS - ... - 3.

GM-TTT permanently supervises the genlock source. An error counter increments in case of any faults, this counter is displayed at menu STATUS - ... - 4. Another error counter increments in case of a failure, this counter is displayed at menu STATUS - ... - 5. Another error counter increments in case of a disturbance, this counter is displayed at menu STATUS - ... - 6. The error counters get an update each frame. Each time the *genlock* button is pressed the error counters get a reset to zero.

4.3 Genlock to a 1pps Signal

- Connect a 1pps signal to pin 1 of DSUB9M REF. DATA IN.
- At menu SET - ... - LOCK select *SEC* and press *enter* button.
- Press *genlock* button.

This genlocking mode should only be used in the *time* operating mode. It must be provided that a real time reference delivers serial data (time and date) as well as a 1pps signal. The LTC output gets a phase adjustment to the reference edge of the 1pps signal, this may be the rising or the falling edge, selectable at menu REFER - MODE 1.

The LED's *genlock* and *intern* indicate the following status:

| | LED <i>genlock</i> | LED <i>intern</i> |
|-----------------------------------|--------------------|-------------------|
| Adjustment procedure, coarse trim | Flashing | Lighting |
| Adjustment procedure, fine trim | Flashing | Off |
| Phase-lock | On | Off |

After switching on this genlocking mode the LED *genlock* starts to flash. The internal reference is selected, but this frequency will be slightly shifted until frame 0 of the time code starts with the reference edge of the 1pps signal. This adjustment procedure starts again after a fail of the genlock caused by a jitter or a disturbance of the 1pps signal. This procedure varies the output frequency of the LTC a little bit but avoids a break in frames.

Using a stable 1pps signal with a jitter < 1.2ms the LED *genlock* will light up after a while, this means a real phase-lock has been reached. During the adjustment procedure the LED *intern* indicates the fine trim (LED off) and the coarse trim (LED lights up).

Fine trim means: frame 0 more than 1.2ms but less than 16ms apart from the 1pps signal.
 Coarse trim means: frame 0 is more or equal than 16ms apart from the 1pps signal.

Reaching a phase-lock is important for a correct timing of the real time data transfer. The serial interface inputs time and date, and the 1pps signal is used as the timing reference to write these data into internal registers. There is a definite moment at each time code frame where the generator reads these registers to prepare the next frame. Having an unstable timing due to an unstable 1pps signal writing into the register may happen one time before, next time past this moment. This will result in generating a discontinuity in frames. Having reached a phase-lock the optimal timing is assured, i.e. a maximal jitter of $\pm 16\text{ms}$ will be allowed. As long as LED *intern* lights up the data transfer is at a critical timing. If for example the data transfer is selected to take place each second (at menu REFER - MODE1) it is not guaranteed to generate a continuous time code. The timing is not critical if the LED *intern* is flashing or off.

GM-TTT permanently supervises the 1pps signal. An error counter increments in case of any faults, this counter is displayed at menu STATUS - ... - 4. Another error counter increments in case of a failure, this counter is displayed at menu STATUS - ... - 5. Another error counter increments in case of a disturbance, this counter is displayed at menu STATUS - ... - 6. The error counters get an update each second. Each time the *genlock* button is pressed the error counters get a reset to zero. At STATUS - ... - 7 the delay between frame 0 and the 1pps signal is indicated. The current programming of the internal reference is displayed at menu STATUS - ... - 3.

5 Operation with a Real Time Reference

5.1 Connection of an External Reference

The standard GM-TTT version uses an external reference, for example with a DCF77 or GPS receiver. At REF.DATA IN, GM-TTT expects to receive a serial data protocol with time, date and status data, as well as a seconds pulse (1pps signal). The data string has to be automatically sent every second. The data transfer should start shortly after the reference edge of the seconds pulse and be completed 220 ms after the reference edge at the latest. The data must refer to this seconds pulse.

- The data transfer format is: 2400/7/E/2.
- The data string consists of 32 ASCII characters:
`<STX>D:01.01.02;T:4;U:14.15.41;#*S!<ETX>`

| | | |
|-----|---------------------------------|---|
| STX | Start of Text | \$02 |
| D: | followed by the date | Day.Month.Year |
| T: | followed by the day of the week | 1-7, 1 = Monday (0 = day of the week is not known). |
| U: | followed by the time | Hours.Minutes.Seconds |
| # | synchronisation after power-on | # = Invalid time, clock is not set since power-on. ' ' = Clock is set. |
| * | current synchronisation | * = Clock in free-run. ' ' = in-sync ("lock"). |
| S | time zone | S = CEST ' ' = CET U = UTC |
| ! | announcement | ! = Announcement of start/end of DST. A = Announcement of a leap second. ' ' = No announcement. |
| ETX | End of Text | \$03 |

5.2 DCF IN Option: Installation of a DCF77 Receiver

If a DCF77 receiver is installed in the GM-TTT, only the antenna remains to be connected at the OPTION 1 connector of the rear panel (BNC 50Ω).

The DCF77 receiver is equipped with an autonomous, battery-buffered clock which continues to count the time during power failure or in free-run mode - when no signal is received - with an accuracy of about 10^{-5} . This clock is set as soon as synchronisation is achieved, and generally it is sufficient to perform synchronisation again once or twice a day. The receiver transmits time, date and status data to the processor of the GM-TTT via an internal serial interface. Normally, the clock of the receiver is set to CET/ CEST.

Antenna installation:

- According to a basic principle, an antenna has to be installed upon the roof! Many problems are avoided when this guideline is followed.
- The antenna should never be placed in close neighbourhood of computers or video monitors.
- The *mod.* and *free* LED's serve to ensure the optimum alignment of the antenna. The *mod.* LED is directly controlled by the receiver and imitates the radio telegram, whereas the *free* LED shows, if the serial data of the receiver indicate the "lock" status. The antenna should be set up in an upright position and slowly rotated, until the *mod.* LED is periodically flashing every second - without any flickering! After some minutes, the *free* LED must go off. If it does not, the antenna should be installed at a different location.
- Remark: In the radio telegram, the 59th second is characterised by the omission of the seconds pulse, i.e. the *mod.* LED does also not flash.

The GM-TTT displays further status data permitting to survey the receiver, please refer to chapter "3.8.3 1... 6: Status Data of the Reference Time".

It is recommended to use the following parameters for operation with this reference time:

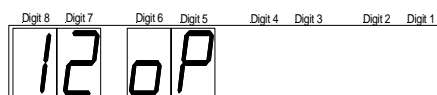

In the REFER - MODE 1 menu: 12 00 P M A, i.e. time and date of the DCF77 receiver are adopted after power-on and periodically once a day. The reference time is handled like a CET/CEST, and the time of the internal clock of the GM-TTT should generally also correspond to this time zone (parameters in the ZONE menu: OFFS1 = 00, OFFS2 = 01).

5.3 GPS IN Option: Installation of a GPS Receiver

If a GPS receiver is installed in the GM-TTT, only the antenna remains to be connected at the OPTION 1 connector of the rear panel.

The GPS Module:

| | |
|--|---|
| <p>The diagram shows a rectangular GPS module. On the left side, there is a connector labeled 'X1' with a grid of pins. Below it is a circular 'Battery' symbol with a warning triangle underneath. At the bottom, there is a row of eight status LEDs labeled 'S1' with sub-labels '1' through '8'. To the right of the LEDs are two indicator lights: a green one labeled '(LED green)' and a red one labeled '(LED red)'. A vertical label '2500-1001-01' is positioned to the right of the module's main body.</p> | <p>The GPS receiver is equipped with an auto-nomous, battery-buffered clock which continues to count the time during power failure or in free-run mode - when no signal is received. This clock is set as soon as synchronisation is achieved, and generally it is sufficient to perform synchronisation again once or twice a day. The receiver transmits time, date and status data to the processor of the GM-TTT via an internal serial interface. Generally the time zone of the GPS module is set to UTC, i.e. no DST is available.</p> |
|--|---|

The specifications of the receiver and the antenna installation are separately described in the manual entitled "GPS Receiver (Built-In)".

| | |
|------------------|--|
| Battery | 3V Lithium, battery life: 10 years |
| Battery exchange |  <p>CAUTION: Danger of explosion if battery is incorrectly placed. Replace only with the same or equivalent type recommended by the manufacturer. Discard used batteries according to the manufacturer's instructions.</p> |

Additional Power Supply via DC IN GPS:

The GM-TTT offers an additional power supply input for the installed GPS receiver. The DC IN GPS (DSUB9M) connector only supplies power to the GPS receiver, whereas the DC IN (XLR4M) connector supplies power to the whole equipment. If a voltage is applied to DC IN (XLR4M), the power supply via DC IN GPS is interrupted by a relay.

GPS Status:

Two LED's at the front side of the GM-TTT are directly controlled by the GPS receiver and provide the following information:

| LED free | Reception status | Received satellites |
|---|---|--|
| Continuously lighting | No synchronisation was performed since power-on. | None |
| Lighting, but shortly interrupted every five seconds. | No synchronisation was performed since power-on. | The number of interruptions equals the number of received satellites. |
| Off, but shortly flashing every five seconds. | Real-time information was received, but no reception possible at present. | No satellite is received, if the LED flashes four times. Every flash less corresponds to one satellite more. |
| Off | In-sync | At least four. |

| LED mod. | |
|--|---|
| Flashing (every second) in case of serial data transmission. | Serves to check that the GPS receiver is powered. |

The GM-TTT displays further status data permitting to check the functionality of the receiver, please refer to chapter "3.8.3 1... 6: Status Data of the Reference Time".

Operation with the GPS Receiver Installed:

It is recommended to use the following parameters for operation with this reference time:

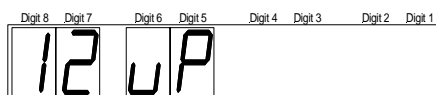

In the REFER - MODE 1 menu: 12 UP, i.e. time and date of the GPS module are adopted after power-on and periodically once a day. The reference time is treated as UTC, while the time of the internal clock of the GM-TTT is defined by the parameters set in the ZONE submenu (time offsets for normal time and DST).

If the GPS module did not have any reception for a long period of time, so that time and date are incorrect, manual setting of the GPS module clock is possible. Time and date of the GPS module are always set, whenever the internal clock of the GM-TTT is set: in the SET - ... - TIME and SET - ... - DATE menu or by using a control unit of the MTD system, if the GM-TTT is serving as the central generator of the MTD Time-Timer-Time Code system.

5.4 Option T: Battery-Buffered Clock Module

This option can be installed instead of using an external reference time input or any other built-in solution. The clock module has a real time clock with a battery backup, counting time and date even if the GM-TTT has been switched off. So the GM-TTT is able to start with a valid real time after power-on.

The clock module counts UTC, i.e. a time zone without Daylight Saving Times.

Time and date of the clock module is set simultaneously with setting time and date of the internal clock: menu SET - ... - TIME and SET - ... - DATE, or with an operational unit of the MTD system, if GM-TTT works as the central unit of the MTD Time-Timer-Time Code system.

This type of reference time input requires to set the following parameters:

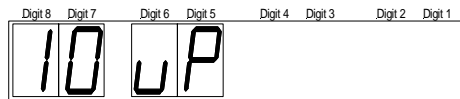

Menu REFER - MODE 1: 10 UP, i.e. GM-TTT accepts time and date only after power-on. The time zone of the reference time is UTC, the time of the internal clock of GM-TTT is defined by the parameters of submenu ZONE (offsets for normal time and DST).

| | |
|--|---|
| | <p>The green LED of the clock module flashes every second, indicating that a valid time and date will be transferred. The red LED lights up in case of an error. The clock module has not received a valid time if the red LED flashes instead of the green LED. This occurs for example after replacing the battery.</p> |
|--|---|

Technical data of the clock module:

| | |
|----------------------------------|---|
| Accuracy (leading edge of P_SEC) | at delivery adjusted to <2ppm/25°C at 15-35°C: <4ppm at 10-40°: <8ppm at 5-45°: <20ppm aging (first year): <3ppm |
| Battery | 3 V lithium, working life: 10 years |
| Replacing the battery | CAUTION: Danger of explosion if battery is incorrectly placed. Replace only with the same or equivalent type recommended by the manufacturer. Discard used batteries according to the manufacturer's instructions. |

5.5 Time Transfer During Normal Operation and Time Jumps

In the *time* operating mode, the GM-TTT generates a "real-time" time code and receives data from a reference clock. Which of the systems is the "master" and how "wrong" or "real" time jumps are treated, is explained as follows.

"Wrong" Time Jumps:

Generally, only a reasonable time and a reasonable date are accepted by the reference clock. Any wrong time jumps might be caused by an interference of the serial interface or a malfunction of the reference clock. The selection of the operating mode in the REFER - MODE 1 menu now determines that the reference clock or the GM-TTT will be the time master.

- If the reference time is adopted every second, no further check is performed, in this case the GM-TTT will always follow the reference clock.
- If the automatic DST mode of the internal clock of the GM-TTT is switched off, the reference clock is rather used as the master. In this case the time is only checked for an up-counting sequence without any time jump.
- If the automatic DST mode of the internal clock of the GM-TTT is switched on, this determines that the GM-TTT is principally always generating a valid time and can only be synchronised to the reference clock in the seconds range. The received time is only accepted, if it is an up-counting sequence without any time jump and if the hours and minutes are coincident with the internal clock of the GM-TTT (taking the offset into account). Exception: A DST switchover or a leap second were correctly announced and carried out by the reference clock.

"Real" Time Jumps:

Twice a year, a DST switchover generates a time jump of one hour, additionally seconds jumps may be generated by inserting a leap second (for adaptation of time to the rotation of the earth) once or twice a year. If the time code is generated in-sync with the video signal and the sync generator is not synchronised to the real time reference, a frame jump may be generated in addition to the above-mentioned time jumps whenever the internal clock is set by the reference time.

The use of real time for the time code has to be discussed in the system context. Problems may occur in systems requiring a continuous time code. These time jumps are real, and any automatic setting which will inevitably lead to time code jumps should only be activated, if this does not result in any system failures. This decision depends upon the following conditions:

1. Priority is given to the precise "real time" of the time code.
2. Priority is given to a continuous time code without any frame jumps.
3. Both conditions shall be achieved.

As for 1. and 2., the GM-TTT offers to program the automatic setting: the reference sets the time into the time code in intervals of seconds, days, weeks, months, years, after the start/end of DST or after a leap second. After the start/end of DST and after a leap second, the time is only transferred, if an announcement occurred within one hour before the event. The daily/-monthly/yearly time transfers may be coupled to the synchronisation of the receiver clock.

Installation & Operation Manual GM-TTT

After a setting has occurred, the amount of time code deviation with respect to "real time" depends upon the accuracy of the crystal (of the GM-TTT or the sync-generator):

Deviation by frames:

| with an accuracy of | after one day | after 30 days |
|---------------------|---------------|---------------|
| 10^{-8} | 0,02 | 0,65 |
| 10^{-7} | 0,2 | 6,5 |
| 10^{-6} | 2 | 65 |

To achieve target 3, the GM-TTT should be synchronised either to a stable seconds pulse of the receiver clock or - if the time code has to be generated in-sync with the video signal - the sync generator has to be externally coupled to real time, i.e. by using a 10MHz clock. This will avoid any frame jumps caused when the real time is transferred to the time code (please also refer to the chapter entitled "Real Time Coupling of Time Code and Video"). In this case the moment of time (every second, every day...) of the time adoption is only relevant with respect to the time jumps caused by a leap second or by the start/end of DST:

- Leap second: A leap second is only precisely generated (as a forecast) in the "every second" setting mode, provided that the leap second was announced. Remark on the leap seconds: The leap seconds were firstly inserted on January 1st 1972. According to the instructions of the IERS (International Earth Rotation Service), the leap seconds are generally inserted by the end of the year or mid-year as the last second of December 31st or June 30 in UTC, i.e. on January 1st at 1:00 o'clock CET or on July 1st at 2:00 o'clock CEST. The leap second is the 60th second of an hour; to supply the leap second, the GM-TTT generates the 59th second twice, i.e. the time sequence in summer is as follows:

| Real Time | | | Time Code of the GM-TTT |
|----------------------|---------|--------------------|-------------------------|
| July 1 st | 1:59:59 | CEST | 1:59:59:23 |
| | | | 1:59:59:24 |
| July 1 st | 1:59:60 | CEST ← leap second | 1:59:59:00 |
| | | | 1:59:59:01 |
| | | | etc. |
| | | | 1:59:59:23 |
| | | | 1:59:59:24 |
| July 1 st | 2:00:00 | CEST | 2:00:00:00 |

- Start/end of DST: The DST switchover is only exactly generated (as a forecast) in the "every second" setting mode or when the automatic DST mode of the internal clock is activated. This requires that the switchover is announced in the "every seconds" setting mode. It further requires that the difference between OFFSET 1 and OFFSET 2 has been correctly selected for the time zone, which is generally + or - one hour (ZONE menu). The GM-TTT will generate the following frame sequence during a switchover to (example):

| | | | |
|-------|-------------|------|-------------|
| CEST: | 01:59:59:23 | CET: | 02:59:59:23 |
| | 01:59:59:24 | | 02:59:59:24 |
| | 03:00:00:00 | | 02:00:00:00 |
| | 03:00:00:01 | | 02:00:00:01 |
| | etc. | | etc. |

5.6 Internal Clock, Automatic DST mode, Binary Groups with Date and Status

The GM-TTT has an internal clock which counts time and date. The start value after power-on is 00:00:00:00 and 01.01.2002. The clock is set manually (SET - ... - TIME, SET - ... - DATE) or by a reference. The time zone of the internal clock is either normal time or DST. Start and end of a DST is calculated from the input values for the day of the week, week of the month and month within the validity range 01.01.1998 - 31.12.2097 - see ZONE menu. Time zone calculation is also carried out every time a new date or hour was set. Any time zone switchover occurs with the next hour following an announcement.

The automatic DST mode is selected in the REFER - MODE 1 menu.

The automatic DST mode permits to switch over the time zone even in case of an interference during reception of the reference time, so that the time code remains precise. It is also possible to use external reception of UTC and generate a random time zone by using offsets. Example for CET/CEST: Offset 1 = +01, Offset 2 = +02.

If date and status bits are transferred in the binary groups (i.e. USER MODE = 3 STATUS), external equipment (such as TC60CLS) can precisely receive the "real time" and the time zones.

The date corresponds to the date of the internal clock.

The BG7.0 status bit is set to 1, if the reference status shows "lock" when time is adopted from a reference. The bit remains set for about 24 hours; if the internal clock is not set again in the "lock" status, it is reset to 0 to indicate that the time code is in free-run.

The BG7.1 and BG7.2 status bits show the current time zone of the internal clock. The time zone is set to UTC, if the reference supplies UTC and the automatic DST mode of the internal clock is not activated.

The BG7.3 status bit announces the start/end of DST. When the automatic DST mode is activated, it is set exactly one hour before the switchover. With the automatic DST mode switched off, it is transferred from the serial data of the reference after the data have been checked (i.e. with a delay of about 4 to 5 minutes) - even when the time is not transferred to the time code.

The BG8.0 status bit announces a leap second. This bit is only set by the serial data of the reference - in analogy with the BG7.3 status bit.

5.7 Real Time Coupling of Time Code and Video

The safest method to generate a real time coupled time code which is in sync with the video signal is to synchronise the video sync generator (SPG) to real time. Some DCF77 or GPS systems offer a stable 10MHz output, and some SPG's may also be coupled by using these 10MHz. Furthermore, a stable seconds pulse is used, which is output from the DCF77 or GPS receiver. A wiring option is shown in the chapter entitled "System Overview".

If this system shall only be locally operated, no special alignment of the systems will be required:

- In the SET - ... - LOCK menu of the GM-TTT, select genlock = *bb* and confirm with *enter*. Press the *genlock* button.
- Switch the SPG to 10MHz genlock. Does the system accept this reference?
- At the GM-TTT the difference between the seconds pulse and the V1 pulse can be measured: in the TEST - 3 menu. Is this value stable?

During power-on and after every change of the synchronisation mode, the GM-TTT measures the phase relationship of the sync pulse compared to the seconds pulse during about 15 seconds (*intern* button, *genlock* button). Then an optimum time is selected for the transfer of real time into the LTC, to avoid any frame jumps during normal operation. The phase relationship of the sync pulse compared to the seconds pulse may be any within ± 20 ms (the 10MHz coupling frequency only avoids any drift of the signals), therefore the LTC may constantly differ from the real time by up to one frame - or four frames when colour lock is used. As an optimum adjustment is only provided, if all used equipment is in a stable operating condition, the automatic alignment should be checked for safety reasons (e.g. after a power failure). Especially a GPS or DCF77 receiver requires more time to achieve stable output frequencies. This condition is checked in the STATUS - ... - 8 menu: optimally, NOBYCMP indicates 0 or 9, critical values are 4 or 5. The more the value differs from 4 (in the range of 0 ... 9), the better. A correction may be performed by reactivating the video synchronisation, i.e. press the *intern* button, then the *genlock* button.

However, if frame 0 of the LTC shall absolutely coincide with the seconds pulse, the sync generator must be aligned to the seconds pulse, because the LTC is of course generated in sync with the video signal:

- At the sync generator, the phase of the signal has to be shifted (vertically, horizontally, μ -seconds) so that the GM-TTT displays the difference 0 in the TEST - ... - 3 menu (the first seven digits of the display). If colour framing is used in the 625/50 TV system: with V4-lock the 8th position must display 1, with V8-lock it must be 3. Important: After this setting has been made, the video synchronisation must be reselected, i.e. press the *intern* button, followed by the *genlock* button. Please note: This setting will be lost when the sync generator is powered off and has to be made again after power-on.

The following diagrams illustrate the behaviour of real time and time code:

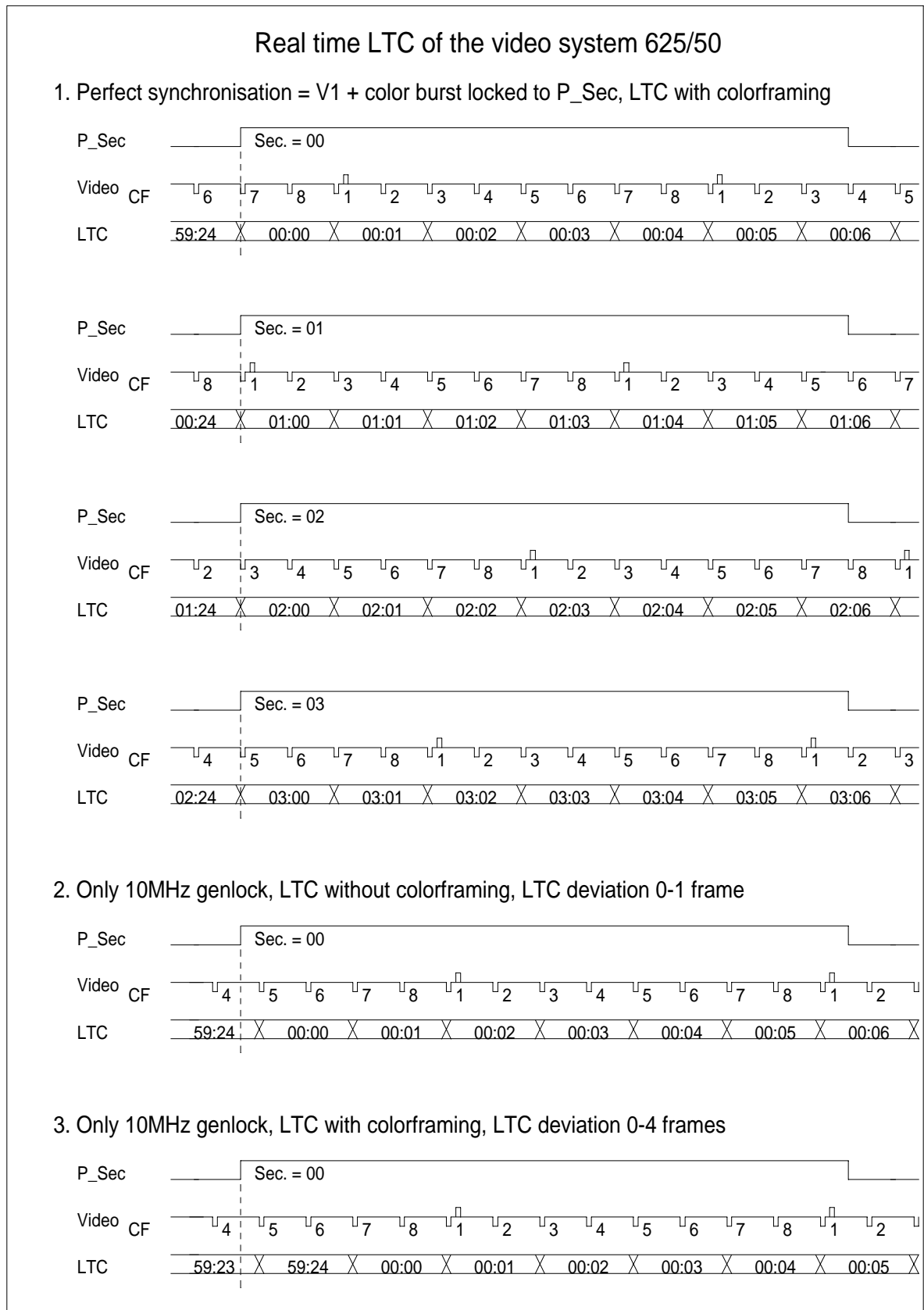

6 Further Details

6.1 Factory Settings

At first delivery or having carried out the function FACTORY RESET the standard unit will have the following settings:

Basically all is set to zero or switched off, except:

| | |
|------------------------------|--|
| Frame rate | 25 |
| LTC output level | 1.5 V _{pp} |
| VITC parameters | Lines 18 and 20 |
| Genlock mode | Video/black-burst |
| User mode | 1 = TTT, i.e. the multiplexed data of the LTC(MTD) |
| Display | Time |
| Key lock | Off |
| LTC generator operating mode | <i>time</i> operating mode |

All settings of the menu will be as in the examples shown in chapter "Detailed Menu Description".

With these parameters GM-TTT operates in the *time* operating mode and is ready to receive the CET/CEST from the reference clock. Automatic pre-set of the internal clock is programmed to occur after power on (after factory reset as well) and once each day at 3 o' clock with respect to the reference time. The time zone parameters of the internal clock gets a pre-set in a way, that CET/CEST will be generated. The binary groups contain the multiplexed data of the LTC(MTD), so the unit is ready to operate with the MTD Time-Timer-Time Code System. This feature is kept during all the *time*, *timer*, *tc* and *start* operating modes, especially the *tc* operating mode is programmed to transfer only time values with an offset equal to zero.

All settings of GM-TTT as well as those of the MTD system - i.e. settings made via any operational units -, are saved in a non-volatile memory. The data and parameters concerning the MTD system and their factory setting are listed in the table below:

| Parameter | A | B | C | D | E | F | real time | date | time address |
|---|-----|-----|-----|-----|-----|------------|-----------|------|--------------|
| Display format (no. 1 - 8) | 1 | 1 | 1 | 1 | 1 | 1 | 7 | 1 | 1 |
| User selectable symbols to separate hours/minutes/seconds: colon, decimal point or without any. | : | : | : | : | : | | . | . | |
| Leading zeroes on/off | off | off | off | off | off | on | off | off | on |
| Leading zeroes at 00:00:00 on/off | off | off | off | off | off | off | - | - | - |
| Flashing when negative | off | off | off | off | off | off | - | - | - |
| Timer mode | UP | UP | UP | UP | UP | VTR LTC | - | - | - |
| Offset | 0 | 0 | 0 | 0 | 0 | 0 | - | - | - |
| Overrun during DOWN on/off | on | on | on | on | on | on | - | - | - |

For details please refer to the manual "MTD Time-Timer-Time Code System: System Operation".

These data may be altogether written into different storage areas. These storage areas are organised as follows:

Area "F": factory settings of GM-TTT; these non-erasable data are stored in a ROM.

Area "S": backup memory, which stores all changes made during current operation. These data are stored in an EEPROM and are hence available after power-on.

Area "U": user area, which permits to store a complete system setting separately. These data are stored in an EEPROM as well.

Area "W": actual working area for current operation. RAM area which changes with new settings.

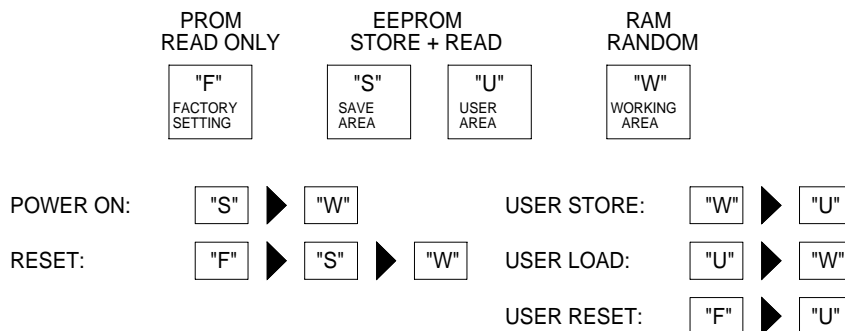

The above diagram shows the storage areas and storage procedures:

1. After power-on "S" is transferred to "W" if "S" has passed the plausibility check.
2. In case of a storage error, "F" overwrites "S", then same proceeding as with 1. Functions 2. and 1. will also be executed with the menu function SET → FACTORY - reset.
3. In the menu function SET → U STORE the actual data may be stored separately.
4. In the menu function SET → U LOAD the actual settings may be overwritten with the stored settings.
5. In the menu function SET → U RESET the user area is overwritten with the factory values.

The parameters of the time zones for timer A - F of the MTD system will be handled separately. These parameters can be transferred between GM-TTT and an operational unit of the MTD system. Programming is done at the operational unit of the MTD system only. The non-volatile storage area of these parameters is checked after power-on separately (see chapter "After Power-on"). This storage area can receive a RESET only at menu ZONE - ... - RESET A-F (not by a FACTORY RESET). This storage area is not included in the 'user area'.

6.2 Maintenance

Placement of fuse, modules, SW1 and pots for adjustments

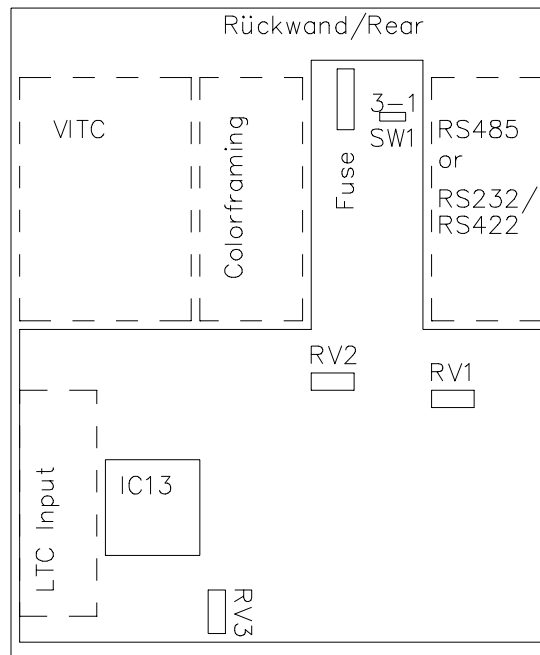

SW1: LTC output floating yes/no:

In position 1 (factory setting) = not floating:

Pin 1 of the LTC Out connector is GND, the signals at pin 2 and 3 are inverted against each other and each of them is symmetrical to pin 1. The output level between 1-2 and 1-3 is set according to the menu. Neither pin 2 nor pin 3 shall be externally connected to GND.

In position 3 (floating):

Pin 1 of the LTC Out connector is the center tap of the transformer, all pins are floating. Pin 1 should be connected to external GND to be able to use a balanced output. To obtain an unbalanced output, pin 2 = GND and pin 3 may be used as the unbalanced signal (or vice versa), then the output level is twice as high as the value indicated in the menu. In this case pin 1 must remain open and should not be connected to GND. A GND connection with the equipment may be realised by using the contact to the XLR connector case.

RV1: Adjusts the LTC output level.

RV2: Adjusts the rise and fall time of the LTC signal.

RV3: Adjusts the frequency of the quartz oscillator.

When aligning with a frequency standard:

IC13.83 = 16 MHz,

IC13.13 = 2 MHz.

When aligning with a video generator in the 625/50 TV system: the measurement result displayed in the TEST - 2 menu should be 39 99 99 37.

7 Optional Modules and Functions

7.1 Colour Lock

Option C: To use this function, the corresponding hardware module must be installed. When displaying the equipment status (after power-on or when pressing the *enter* button with the deactivated menu) it is possible to check, if the module was detected.

Colour framing is performed by using the signal at the VIDEO/BB BNC connector; this signal is also used for video synchronisation.

Genlock = *bb* must be activated: In the SET - ... - LOCK menu of the GM-TTT, genlock = *bb* is selected and confirmed with *enter*. Press the *genlock* button. The colour lock mode is switched on and off in the same menu.

Colour lock is only provided for the 625/50 TV system. The V4 lock mode is derived from the burst inserted into the video signal. For the V8 colour lock mode, a luminance signal (white flag) is expected in line 7, which characterises the first field of the 8 field sequence. Most sync generators permit to configure the Black-Burst output this way. The luminance pulse should have a pulse duration of at least 16µs.

The *cf* LED supplies the following status messages:

| LED <i>cf</i> | Status |
|------------------|---|
| off | Colour lock mode is deactivated. |
| on | Colour lock mode is activated, and the corresponding status bit is set in the time code, i.e. a V8 lock has occurred in the 625/50 TV system. |
| slowly flashing | Colour lock mode is activated, and a V4 lock has occurred in the 625/50 TV system. |
| quickly flashing | Colour lock mode is activated, but no colour lock has occurred. |

As soon as colour lock has occurred, any interference during the detection of the colour sequence are bridged up to a duration of 10 seconds, then the *cf* LED starts to flash in short intervals. Any failure of the video synchronisation will shorten this period to 5 seconds.

When colour lock is activated, every time value set in the generator (manually by using buttons, by "real-time" coupling or Jam-Sync) is checked and eventually corrected, so that the address of the colour sequence is maintained. This permits to regenerate continuous external time values adjusted to a colour framing. If the Jam-Sync function stops, the colour lock mode is automatically interrupted.

7.2 VITC Generator

Option V: To use this function, the corresponding hardware module must be installed. When displaying the equipment status (after power-on or pressing the *enter* button with deactivated menu), it is possible to check, if the module was detected.

VITC is inserted into the signal at the VIDEO/BB BNC connector and output at the OPTION 2 BNC connector. The VITC data are identical with the LTC data.

Genlock = *bb* must be switched on: In the SET - ... - LOCK menu of the GM-TTT, genlock = *bb* is selected and confirmed with *enter*. Press the *genlock* button.

The VITC lines can be adjusted in the VITC menu. The permissible range of lines is 6 - 32. The standard ANSI/SMPTE 12M-1995 specifies a line range of 6-22 for television system 625/50 (PAL, frame rate = 25) or 10-20 for television system 525/60 (NTSC, frame rate = 30Drop), respectively. It is possible to select between 2-line mode or block mode.

7.3 Serial Remote Control Interface

7.3.1 General

In this option, the standard RS485 module is replaced by a RS232 module (option 2) or a RS422 module (option 4). With that GM-TTT can no longer work as a central unit of the MTD system, because now the communication interface to the control units of this system is missing.

The GM-TTT may be partially remote-controlled via the serial RS232 or RS422 interface. The current time code data may be requested. In the data format, 8 data bits and 1 stop bit are fixed, while parity bit and baud rate are adjustable.

The GM-TTT reacts to commands or requests. The received or sent data string has the following structure:

| | | | | | | |
|-----------|--------|--------|--------|-----|----------|----------|
| Byte 1 | Byte 2 | Byte 3 | Byte 4 | ... | Byte n+2 | Byte n+3 |
| CMD1 / DC | CMD2 | DATA 1 | DATA 2 | ... | DATA n | CHECK |

CMD1 Command 1, specifies the group of commands:

- 0 = System control
- 4 = Set data
- 6 = Request data

DC Number of data bytes (Data Count), \$0 - \$F.

CMD2 Command 2, specifies the command within the group.

DATA 1... Data bytes, number as specified by DC.

CHECK hexadecimal sum of the bytes 1 to n+2 without carryover.

- A sent data string must be coherent, i.e. the time gap between individual bytes shall not exceed > 10 ms.
- A new command should only be transmitted if the return of the preceding command has been received.
- Please note: unlike for operation with keys, new equipment settings are not stored in the non-volatile memory.

Installation & Operation Manual GM-TTT

7.3.2 Commands

| Description | CMD 1/DC | CMD 2 | DATA | CHECK | Description | CMD 1/DC | CMD 2 | DATA | CHECK |
|---|----------|-------|------|---------|-------------|----------|-------|------|---------|
| Device type Request | \$00 | \$11 | - | \$11 | Device type | \$12 | \$11 | *1 | \$CHECK |
| Generator "Start" | \$01 | \$86 | \$00 | \$87 | ACK | \$10 | \$01 | - | \$11 |
| Generator "Stop" | \$01 | \$86 | \$01 | \$88 | ACK | \$10 | \$01 | - | \$11 |
| Pre-set time of the time code *7 | \$44 | \$04 | *2 | \$CHECK | ACK | \$10 | \$01 | - | \$11 |
| Pre-set binary groups of the time code *7 | \$44 | \$05 | *3 | \$CHECK | ACK | \$10 | \$01 | - | \$11 |
| Pre-set the date of the internal clock | \$44 | \$06 | *4 | \$CHECK | ACK | \$10 | \$01 | - | \$11 |
| Pre-set the time of the internal clock | \$44 | \$07 | *2 | \$CHECK | ACK | \$10 | \$01 | - | \$11 |
| Request time | \$61 | \$0A | \$01 | \$6C | Time | \$74 | \$08 | *2 | \$CHECK |
| Request user | \$61 | \$0A | \$10 | \$7B | User | \$74 | \$09 | *3 | \$CHECK |
| Request time + user | \$61 | \$0A | \$11 | \$7C | Time + User | \$78 | \$08 | *5 | \$CHECK |
| Request time + flag | \$61 | \$0A | \$02 | \$6D | Time + Flag | \$74 | \$08 | *6 | \$CHECK |
| Request the date of the internal clock | \$61 | \$0A | \$20 | \$8B | Datum | \$74 | \$09 | *4 | \$CHECK |
| Request the time of the internal clock | \$61 | \$0A | \$21 | \$8C | Time | \$74 | \$08 | *2 | \$CHECK |

\$CHECK hexadecimal sum of the previous bytes

ACK Acknowledge, 'ok' return

NAK In case of an interference or an error, a NAK (= not acknowledge) = error message may be sent as a return:

\$11 \$12 \$FEHLER \$CHECK, with \$FEHLER =

Bit 7: -

Bit 6: framing error

Bit 5: overrun

Bit 4: parity

Bit 3: -

Bit 2: check sum

Bit 1: incongruent data

Bit 0: undefined command

- *1 DATA 1: Bit 7 = 1
 Bit 6 = 0
 Bit 5 = 1 Bits 7..5 = Device type
 Bit 4
 Bit 3
 Bit 2: 1 = Colour lock module installed, 0 = not installed
 Bit 1: 1 = Serial interface module installed, 0 = not installed
 Bit 0: 1 = VITC generator module installed, 0 = not installed
 DATA 2: BCD firmware version
- *2 DATA 1 = BCD frames
 DATA 2 = BCD seconds
 DATA 3 = BCD minutes
 DATA 4 = BCD hours
- *3 DATA 1 = BG1/2 user bits
 DATA 2 = BG3/4 user bits
 DATA 3 = BG5/6 user bits
 DATA 4 = BG7/8 user bits
- *4 DATA 1 = BCD day
 DATA 2 = BCD month
 DATA 3 = BCD year (units, tens)
 DATA 4: is ignored when setting, during return = internal time zone:
 \$00 = UTC or not defined
 \$01 = normal time
 \$02 = Daylight Saving Time
- *5 DATA 1..4 = time as for *2, DATA 5-8 = user bits as for *3.
- *6 The "flag" characterises the first/second half of each frame, it is = 0 in the first and = 1 in the second half (corresponding to the VITC field identification). It is sent as bit 7 of DATA 4, i.e. as the most significant bit of the hours. To ensure optimum usability, the baud rate should be selected as high as possible. The time at which the command was completely received defines the value of the "flag" in the return message.
- *7 The 'Pre-set time of the time code' command is only effective, when the *start* operating mode is selected. The 'Pre-set binary groups of the time code' command has the same effect as the SET USER menu function. The time and binary groups of the generated time code may be set frame by frame. Internally, the LTC generator accepts any set data within the t1 to t2 range (t1/t2 about 10/13 ms at 25 frames, 9/12 ms at 30 frames), this corresponds to the line range 160 - 200 (625/50 PAL) or 140 - 190 (525/60 NTSC) in case of video synchronisation. In this range, the last byte of the command should not be received, if frame-accurate setting has to be achieved. If the last byte of the command is received within the range specified in the diagram, the set data are safely generated to supply frame 3 for example.

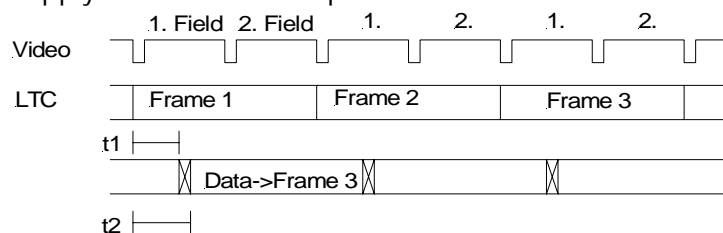

7.4 Reference Time Input via External LTC

7.4.1 General

This function requires a special firmware and a hardware module (option L). When displaying the equipment status (after power-on or pressing the *enter* button with deactivated menu), the presence of this special feature will be indicated during the second step of the status messages: digit 5 shows a "3".

Basically this special feature is only a different way of a reference time input. Instead of a 1 PPS signal and time/date via a serial interface the external LTC - connected at LTC IN - serves as the reference time.

All the settings at sub-menus REFERENCE and ZONE are valid as usual. The settings at sub-menu LTC IN have no effect on the reference time. Programming an offset between the reference time and the internal clock is done at sub-menu ZONE, not at sub-menu LTC IN.

During main operating mode = *time*, the LTC output of GM-TTT will be frame accurate to the external LTC if the LTC of GM-TTT is locked to the external LTC (genlock = *LTC*) or if both LTCs are locked to the same source (e.g. to the same black-burst).

7.4.2 Accepting Time, Date and Status Information of the External LTC

GM-TTT accepts the reference time from the LTC input after the LTC has passed three tests: 'forward' direction must be detected, it must contain a valid time and the time addresses of two consecutive frames must be in ascending and continuous order.

The binary groups of the LTC input may carry the date and status information. To select the right format of these data the sub-menu REFER - MODE 1 has been extended by the field RT-LTC (digit 4):

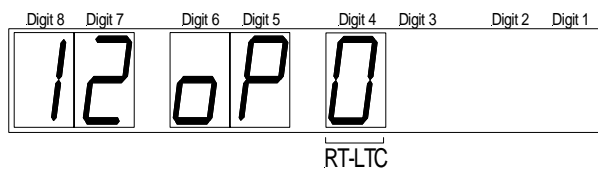

| RT-LTC | Description |
|--------|---|
| 0, 1 | <p>The LTC input does not carry date and status information.</p> <p>The date will be the date of the internal clock of GM-TTT.</p> <p>There is no status available from the LTC input, so the status is set to:</p> <ul style="list-style-type: none"> • time zone = UTC, • "lock" status = free-run, • antenna signal = received, • no announcements (Daylight Saving Times changes or Leap Second). |

| | |
|-------------------|--|
| 2, 4 - 9, A, b | <p>The LTC input carries a date as described for the corresponding numbers at sub-menu SET - ... - USER MOD (2 = 2 <i>DATE</i>, 4 = 4 <i>BBC</i>, etc.). Selection b = b <i>OFF</i> works same way as selection 4 = 4 <i>BBC</i>, i.e. no offset will be calculated. RT-LTC can be selected independent from a selection at USER MOD.</p> <p>There is no status available from the LTC input, so the status is set as described for RT-LTC selection 0 or 1.</p> |
| 3 | The LTC input carries date and status information according to the specification of USER MOD = 3 <i>STATUS</i> (sub-menu SET - ... - USER MOD). |

The flashing of the LED *mod.* indicates, that the time information has passed the checks and that a valid date has been detected in the binary groups of the LTC (if RT-LTC is not equal to 0 or 1).

7.4.3 Examples

In general the following settings are recommended at sub-menu REFERENCE:

REFER - MODE 1: Power-On (Digit 8) = 1
 Auto (Digit 7) = 2

REFER - ... - MODE 2: Lock (Digit 6) = b

Example 1: Gain a local time with a fixed offset to the reference time

The LTC input carries a time (e.g. UTC) without Daylight Saving Time (DST) switching, and a date conforming to the specification of GM-TTT *USER MOD = 2 DATE* or = 3 *STATUS*. The LTC output should have a local time, again without DST switching.

- At sub-menu REFER - MODE 1: Mode (Digit 6) = 0,
 RT-LTC (Digit 4) = 2.
- At sub-menu ZONE - OFFS 1: select time offset: reference time + offset = local time.

Example 2: Gain a local time with DST switching

The LTC input carries a time (e.g. UTC) without Daylight Saving Time (DST) switching, and a date conforming to the specification of GM-TTT *USER MOD = 2 DATE* or = 3 *STATUS*. The LTC output should have a local time with DST switching.

- At sub-menu REFER - MODE 1: Mode (Digit 6) = u,
 RT-LTC (Digit 4) = 2.
- At menu ZONE: select all settings to program the offsets and the moment of DST switching, please refer to the manual. Example for input UTC, output CET/CEST:
 - OFFS 1: +1
 - OFFS 2: +2
 - DST on: 5 7 03 02
 - DST off: 5 7 10 03

Installation & Operation Manual GM-TTT

Page 80

Example 3: Input = output = CET/CEST

The LTC input carries a time (e.g. CET/CEST) with Daylight Saving Time (DST) switching, and a date and status information. The LTC input conforms to the specification of GM-TTT *USER MOD = 3 STATUS*. The LTC output should have the same time zone.

- At sub-menu REFER - MODE 1: Mode (Digit 6) = 0 or A,
RT-LTC (Digit 4) = 3.
- At sub-menu ZONE: OFFS1: +0
OFFS 2: +1
DST on: 5 7 03 02
DST off: 5 7 10 03

Example 4: Input CET/CEST without status information, output CET/CEST

The LTC input carries a time (e.g. CET/CEST) with Daylight Saving Time (DST) switching and a date, but no status information. The LTC input conforms to the specification of GM-TTT *USER MOD = 2*. The output should have the same time zone.

- At sub-menu REFER - MODE 1: Mode (Digit 6) = 0,
RT-LTC (Digit 4) = 2.
- At sub-menu ZONE - OFFS 1: +0.

7.5 Seconds and Minutes Pulse Output

Option P: this option requires an additional hardware. When displaying the equipment status (after power-on or pressing the *enter* button with deactivated menu), it is possible to check, if this option is present:

- At first step of status display digit 1 shows an "o".
- At second step of status display digits 2 and 1 show the identification "03".

The pulses have TTL level (0-5 V) and are connected at female DSUB GPI or - when application with AS-TTT is required - at female DSUB MTD:

| Signal | Connector GPI | Connector MTD |
|---------------|---------------|---------------|
| Seconds Pulse | Pin 3 | Pin 6 |
| Minutes Pulse | Pin 4 | Pin 7 |
| GND | Pin 5 | Pin 8 |

The pulses are locked to the LTC output and are triggered from the time of the internal clock. Using the pulses together with the time information of the LTC the main operating mode *time* has to be selected.

The polarity of the pulses can be selected at menu SET - ... - F-RATE:

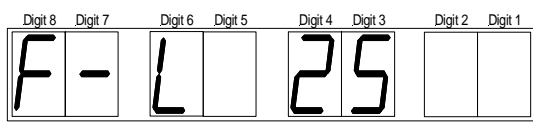

Digit 6 = *H* "High" = positive pulse

Digit 6 = *L* "Low" = negative pulse

The following diagram shows the detailed timing.

The seconds pulse starts one LTC bit before the beginning of the first frame of the new second (leading edge = reference mark). The pulse duration is equal to one LTC frame.

The edges of the minutes pulse occur approximately 15 μ s before the reference mark of the seconds pulse. The pulse duration of the minutes pulse is equal to one second.

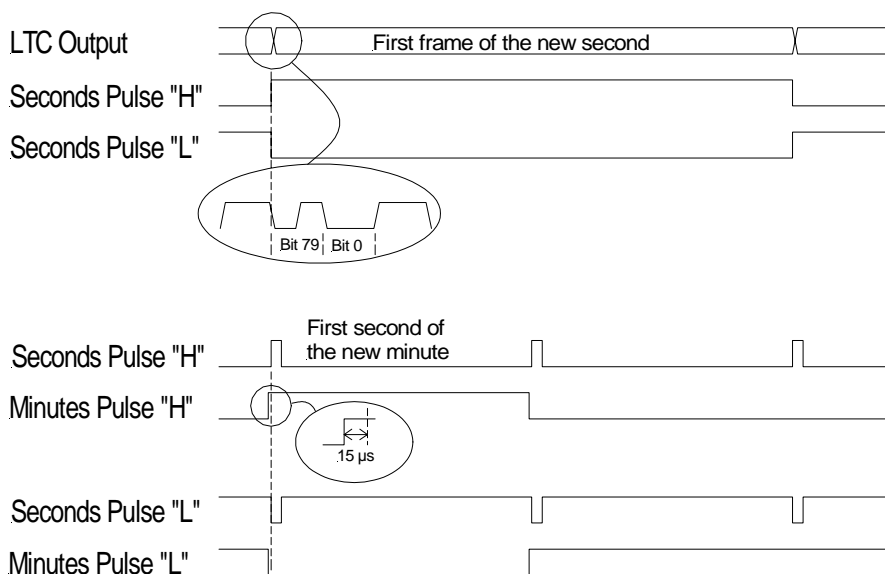

7.6 Analogue Master Output

Option A: this option requires an additional hardware. This option can be installed together with option DCF IN or GPS IN.

With this option a distribution amplifier supplies the analogue clocks of the *Alpermann + Velte* MTD system with power as well as with time data. The time data forms a telegram similar to the German radio time telegram DCF77. The data bits are transmitted every second except at seconds = 59. The time data are synchronous to the P_SEC signal of the built-in DCF or GPS receiver. The time exactly corresponds to the time which is transmitted by the built-in DCF or GPS receiver.

Below the pin assignment of the DSUB9 female connector GPI and a wiring example:

| from Master Output | to Analogue Clocks |
|--------------------|-------------------------------|
| DSUB9F | open ends (to screwing posts) |
| 1: V+ Out | Vdd (1) |
| 2: V- Out | GND (2) |
| 7: Signal Out | Signal (3) |
| 8: Signal GND | GND (4) |

The pins not specified should not be used. Use e.g. a two-paired, twisted cable, twist 1 with 2 and 7 with 8.

Every slave clock requires $\leq 11\text{mA}$ at $\geq 6\text{V}$. To calculate the maximum cable length the output voltage, cross section, specific resistance and number of clocks have to be involved. For radial arrangement of copper cables with a cross section of $0,22\text{mm}^2$ and a output voltage of 12V, the following cable lengths are possible:

| no. of clocks | 1 | 2 | 5 | 10 | 20 | 30 |
|---------------|------|------|-----|-----|-----|-----|
| length (m) | 3500 | 1750 | 700 | 350 | 175 | 117 |

The maximum count of clocks is limited by a 300mA fuse to 30 clocks. A control LED at the front is directly connected to the signal output:

| | |
|----------------------------|---|
| <input type="radio"/> free | <input type="radio"/> 30 |
| <input type="radio"/> mod. | <input type="radio"/> 25 |
| <input type="radio"/> cf | <input checked="" type="radio"/> Signal Out |

This option changes the technical data of the unit. Use only the AC/DC adapter delivered with the unit!

| Item | Specification |
|---|---------------------------------------|
| Input voltage | 10 -18 V DC (instead of 10 - 30 V DC) |
| Power (GM-TTT with Option GPS IN + Option A) | typical 6 W, max. 11 W |