



# SYSTEM INTEGRATION AUDIO PROCESSOR PXA-H800

- INSTALLATION MANUAL
- GUIDE D'INSTALLATION
- MANUAL DE INSTALACIÓN

EN  
FR  
ES

**ALPINE ELECTRONICS MARKETING, INC.**  
1-1-8 Nishi Gotanda,  
Shinagawa-ku,  
Tokyo 141-0031, Japan  
Phone 03-5496-8231

**ALPINE ELECTRONICS OF AMERICA, INC.**  
19145 Gramercy Place, Torrance,  
California 90501, U.S.A.  
Phone 1-800-ALPINE-1 (1-800-257-4631)

**ALPINE ELECTRONICS OF CANADA, INC.**  
777 Supertest Road, Toronto,  
Ontario M3J 2M9, Canada  
Phone 1-800-ALPINE-1 (1-800-257-4631)

**ALPINE ELECTRONICS OF AUSTRALIA PTY. LTD.**  
161-165 Princes Highway, Hallam  
Victoria 3803, Australia  
Phone 03-8787-1200

**ALPINE ELECTRONICS GmbH**  
Wilhelm-Wagenfeld-Str. 1-3,  
80807 München, Germany  
Phone 089-32 42 640

**ALPINE ELECTRONICS OF U.K. LTD.**  
Alpine House  
Fletchamstead Highway,  
Coventry CV4 9TW, U.K.  
Phone 0870-33 33 763

**ALPINE ELECTRONICS FRANCE S.A.R.L.**  
(RCS PONTOISE B 338 101 280)  
98, Rue de la Belle Etoile, Z.I. Paris Nord II,  
B.P. 50016, 95945 Roissy Charles de Gaulle  
Cedex, France  
Phone 01-48638989

**ALPINE ITALIA S.p.A.**  
Viale C. Colombo 8, 20090 Trezzano  
Sul Naviglio (MI), Italy  
Phone 02-484781

**ALPINE ELECTRONICS DE ESPAÑA, S.A.**  
Portal de Gamarra 36, Pabellón, 32  
01013 Vitoria (Alava)-APDO 133, Spain  
Phone 945-283588

**ALPINE ELECTRONICS (BENELUX) GmbH**  
Leuvensesteenweg 510-B6,  
1930 Zaventem, Belgium  
Phone 02-725-13 15



# Contents

## WARNING

WARNING .....	2
CAUTION .....	2
PRECAUTIONS .....	2

## Installation and Connections

Mounting the Base Unit (PXA-H800).....	3
Preparation .....	3
Installation example 1 .....	3
Installation example 2 .....	3
Mounting the Microphone .....	4
Mounting the Commander Unit (RUX-C800)	
(Sold separately) .....	5
Preparation .....	5
Installing with Adhesive sheet.....	5
Installing with Commander unit holder.....	5
Connections .....	8
System Example .....	12
Connecting an automobile factory system (standard audio, etc.) and External Amplifier .....	12
Connecting a Non Ai-NET AV Head Unit, External Input and External Amplifier.....	14
Connecting a Non Ai-NET Head Unit, External Input and External Amplifier .....	15
Connecting an Ai-NET compatible AV Head Unit (INA-W910), ALPINE Navigation System, Ai-NET compatible Changer and External Amplifier.....	16
Connecting an Ai-NET compatible Head Unit, Ai-NET compatible Changer and External Amplifier.....	18
Confirmation .....	19

## WARNING



### WARNING

This symbol means important instructions. Failure to heed them can result in serious injury or death.

#### DO NOT DISASSEMBLE OR ALTER.

Doing so may result in an accident, fire or electric shock.

#### KEEP SMALL OBJECTS SUCH AS BOLTS OR SCREWS OUT OF THE REACH OF CHILDREN.

Swallowing them may result in serious injury. If swallowed, consult a physician immediately.

#### USE THE CORRECT AMPERE RATING WHEN REPLACING FUSES.

Failure to do so may result in fire or electric shock.

#### BEFORE WIRING, DISCONNECT THE CABLE FROM THE NEGATIVE BATTERY TERMINAL.

Failure to do so may result in electric shock or injury due to electrical shorts.

#### DO NOT SPLICE INTO ELECTRICAL CABLES.

Never cut away cable insulation to supply power to other equipment. Doing so will exceed the current carrying capacity of the wire and result in fire or electric shock.

#### DO NOT INSTALL IN LOCATIONS WHICH MIGHT HINDER VEHICLE OPERATION, SUCH AS THE STEERING WHEEL OR SHIFT LEVER.

Doing so may obstruct forward vision or hamper movement etc. and results in serious accident.

#### DO NOT DAMAGE PIPE OR WIRING WHEN DRILLING HOLES.

When drilling holes in the chassis for installation, take precautions so as not to contact, damage or obstruct pipes, fuel lines, tanks or electrical wiring. Failure to take such precautions may result in fire.

#### DO NOT USE BOLTS OR NUTS IN THE BRAKE OR STEERING SYSTEMS TO MAKE GROUND CONNECTIONS.

Bolts or nuts used for the brake or steering systems (or any other safety-related system), or tanks should NEVER be used for installations or ground connections. Using such parts could disable control of the vehicle and cause fire etc.

#### DO NOT ALLOW CABLES TO BECOME ENTANGLED IN SURROUNDING OBJECTS.

Arrange wiring and cables in compliance with the manual to prevent obstructions when driving. Cables or wiring that obstruct or hang up on places such as the steering wheel, shift lever, brake pedals, etc. can be extremely hazardous.

#### MAKE THE CORRECT CONNECTIONS.

Failure to make the proper connections may result in fire or product damage.

#### DO NOT INSTALL THE MONITOR NEAR THE PASSENGER SEAT AIR BAG.

If the unit is not installed correctly the air bag may not function correctly and when triggered the air bag may cause the monitor to spring upwards causing an accident and injuries.

#### DO NOT BLOCK VENTS OR RADIATOR PANELS.

Doing so may cause heat to build up inside and may result in fire.

#### USE ONLY IN CARS WITH A 12 VOLT NEGATIVE GROUND.

(Check with your dealer if you are not sure.) Failure to do so may result in fire, etc.

#### DO NOT OPERATE ANY FUNCTION THAT TAKES YOUR ATTENTION AWAY FROM SAFELY DRIVING YOUR VEHICLE.

Any function that requires your prolonged attention should only be performed after coming to a complete stop. Always stop the vehicle in a safe location before performing these functions. Failure to do so may result in an accident.

#### KEEP THE VOLUME AT A LEVEL WHERE YOU CAN STILL HEAR OUTSIDE NOISES WHILE DRIVING.

Excessive volume levels that obscure sounds such as emergency vehicle sirens or road warning signals (train crossings, etc.) can be dangerous and may result in an accident. LISTENING AT LOUD VOLUME LEVELS IN A CAR MAY ALSO CAUSE HEARING DAMAGE.

#### USE THIS PRODUCT FOR MOBILE 12V APPLICATIONS.

Use for other than its designed application may result in fire, electric shock or other injury.



### CAUTION

This symbol means important instructions. Failure to heed them can result in injury or material property damage.

#### USE SPECIFIED ACCESSORY PARTS AND INSTALL THEM SECURELY.

Be sure to use only the specified accessory parts. Use of other than designated parts may damage this unit internally or may not securely install the unit in place. This may cause parts to become loose resulting in hazards or product failure.

#### DO NOT INSTALL IN LOCATIONS WITH HIGH MOISTURE OR DUST.

Avoid installing the unit in locations with high incidence of moisture or dust. Moisture or dust that penetrates into this unit may result in product failure.

#### HAVE THE WIRING AND INSTALLATION DONE BY EXPERTS.

The wiring and installation of this unit requires special technical skill and experience. To ensure safety, always contact the dealer where you purchased this product to have the work done.

#### ARRANGE THE WIRING SO IT IS NOT CRIMPED OR PINCHED BY A SHARP METAL EDGE.

Route the cables and wiring away from moving parts (like the seat rails) or sharp or pointed edges. This will prevent crimping and damage to the wiring.



### PRECAUTIONS

- Be sure to disconnect the cable from the (-) battery post before installing your PXA-H800. This will reduce any chance of damage to the unit in case of a short-circuit.
- Be sure to connect the color coded leads according to the diagram. Incorrect connections may cause the unit to malfunction or damage to the vehicle's electrical system.
- When making connections to the vehicle's electrical system, be aware of the factory installed components (e.g. on-board computer). Do not tap into these leads to provide power for this unit. When connecting the PXA-H800 to the fuse box, make sure the fuse for the intended circuit of the PXA-H800 has the appropriate amperage. Failure to do so may result in damage to the unit and/or the vehicle. When in doubt, consult your Alpine dealer.
- The PXA-H800 uses female RCA-type jacks for connection to other units (e.g. amplifier) having RCA connectors. You may need an adaptor to connect other units. If so, please contact your authorized Alpine dealer for assistance.
- Be sure to connect the speaker (-) leads to the speaker (-) terminal. Never connect left and right channel speaker cables to each other or to the vehicle body.

#### IMPORTANT

Please record the serial number of your unit in the space provided below and keep it as a permanent record. The serial number or the engraved serial number is located on the bottom of the unit.

SERIAL NUMBER: \_\_\_\_\_

INSTALLATION DATE: \_\_\_\_\_

INSTALLATION TECHNICIAN: \_\_\_\_\_

PLACE OF PURCHASE: \_\_\_\_\_

# Installation and Connections

## Mounting the Base Unit (PXA-H800)

### Preparation

#### 1 Check accessory parts.

① Power cable

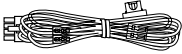

② Ai-NET extension cable (5.5 m)

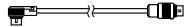

③ USB cable (5 m)

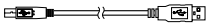

④ Speaker-RCA Conversion cable (20 cm) (Red/White x3 sets)



⑤ Bracket



⑥ Microphone (1 set)



<Microphone>

<Clip>

<Adhesive tape>

⑦ Screw (M3 x 6 mm)



⑧ Self-tapping screw (M4 x 14 mm)



(x4)

(x4)

⑨ Velcro fastener\*1

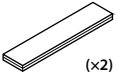

(x2)

⑩ CD-ROM\*2, \*3



(x2)

\*1 Use when necessary.

\*2 For details on how to install and use the CD-ROM, "Sound Manager for PXA-H800," refer to the Owner's Manual - PC guide.

\*3 For details on how to install and use the CD-ROM, "SETUP DISC," refer to the Owner's Manual - PC guide.

### Installation example 1

#### ■ Set the installation location.

- Check that the provided cord is sufficiently long. Install the unit where it is not exposed to water.  
Do not install the unit or wiring where it interferes with driving or an air bag.

#### 1 Affix the bracket ⑤ to the device tightly with the 4 screws (M3 x 6 mm) ⑦.

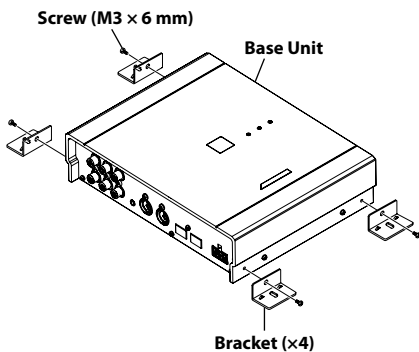

#### 2 Mark the installation screw positions at the installation location.

#### 3 Drill (3mm diameter max.) in the marked positions.



#### WARNING

When making holes, be careful not to damage pipes, tanks, electric wires, etc. Doing so could lead to an accident or fire.

#### 4 Install the device tightly with 4 self-tapping screws (M4 x 14 mm) ⑧.

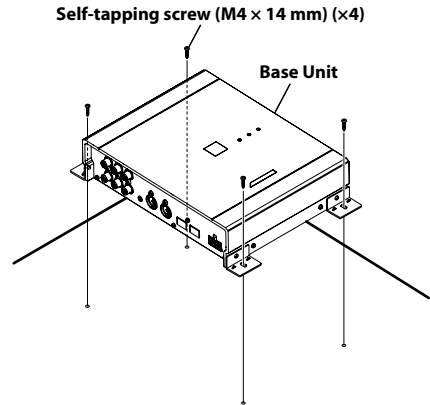

### Installation example 2

#### 1 Cut out the external box paper template along the perforation.

#### 2 Temporarily hold the paper template in place at the installation position with adhesive tape.

#### 3 Put a bracket ⑤ in a predetermined position on the paper template and mark where a screw is to be fixed.

For details on how to install the brackets, refer to step 5.

#### 4 Drill a hole (3mm diameter max.).



#### WARNING

When making holes, be careful not to damage pipes, tanks, electric wires, etc. Doing so could lead to an accident or fire.

- 5** Tightly install the bracket ⑤ at the designated paper template position with the 4 self-tapping screws (M4 x 14 mm) ⑧.

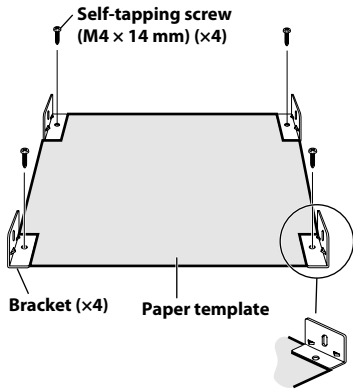

Mount the brackets symmetrically along the paper template.

- 6** Remove the paper template.

- 7** Place the Base unit on the bracket ⑤ and install the device tightly with the 4 screws (M3 x 6 mm) ⑦.

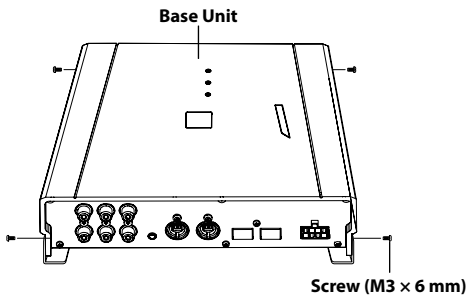

## Mounting the Microphone.

When measuring ImprintEQ or AutoTCR before implementing RoadEQ automated measurement, the installation position is different. Before installing the microphone, make sure to refer to "Automatic Measurement Function" in the Owner's Manual – PC or Commander guide.

For safe use, make sure of the following:

- location is stable and firm.
- driver's view and operations are not obstructed.
- Mount the road noise measurement microphone on the sun visor, dashboard or roof interior.
- Installation on the sun visor is the most common installation position to measure road noise while driving.
- Do not install the unit or wiring in a location that interferes with driving or an air bag.

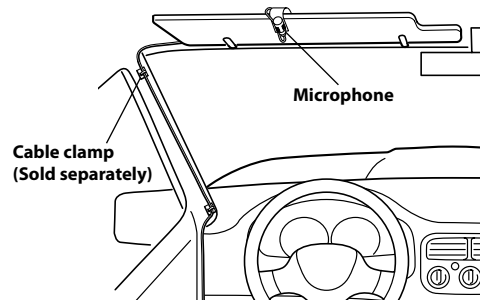

- The mounting clip can be removed from the microphone base, as in the illustration below. If you mount the microphone using the base without the clip, use the supplied adhesive tape as needed.

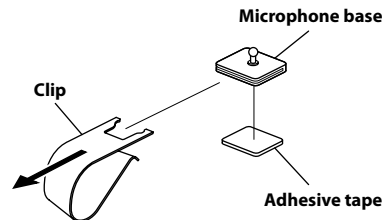

# Mounting the Commander Unit (RUX-C800) (Sold separately)

## Preparation

### 1 Check accessory parts.

① Commander cable (5 m)

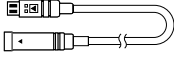

② Commander unit holder

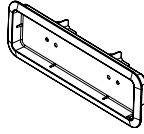

③ Bracket

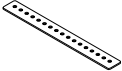

④ Screw (M3 × 6 mm)



⑤ Self-tapping screw (M4 × 14 mm)



⑥ Adhesive sheet (1 set)

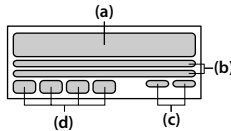

## Installing with Adhesive sheet

### ■ Set the installation location.

- Check that the provided cord is sufficiently long. Install the unit where it is not exposed to water.
- Do not install the unit or wiring where it interferes with driving or an air bag.

### 1 Using the Adhesive sheet (a) ⑥, install on the console or dashboard.

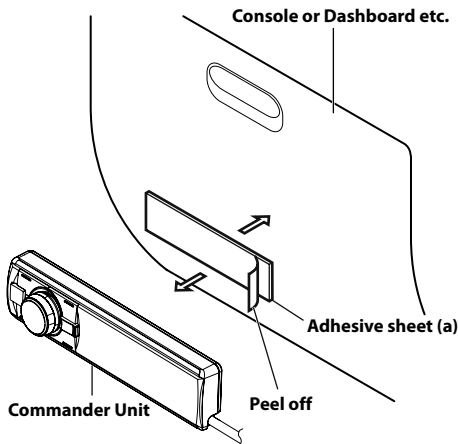

## Installing with Commander unit holder

### ■ Set the installation location.

- Check that the provided cord is sufficiently long. Install the unit where it is not exposed to water.
- Do not install the unit or wiring where it interferes with driving or an air bag.
- Console or dashboard, etc.
- \* Remove the components to which this product will be installed from the automobile before installing.

### 1 Cut out the external box paper template along the perforation.

### 2 Temporarily hold the paper template in place at the installation position with adhesive tape.

### 3 Cut installation holes along the paper template with a utility knife.

#### ⚠ WARNING

When making holes, be careful not to damage pipes, tanks, electric wires, etc.

Doing so could lead to accidents or fire.

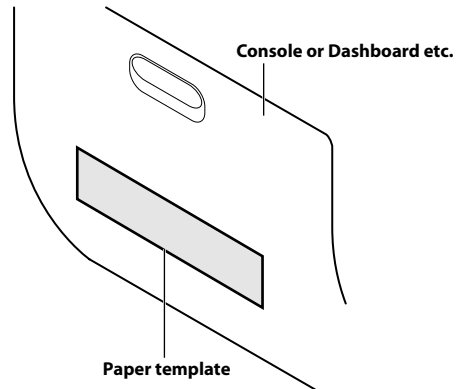

#### ⚠ CAUTION

If the installation holes are too big, the Commander unit can rattle or come off while driving. Make sure to use the paper template.

- 4** Bend the bracket ③ to follow the curvature of the Commander unit holder ② and the console or the underside of the dashboard.

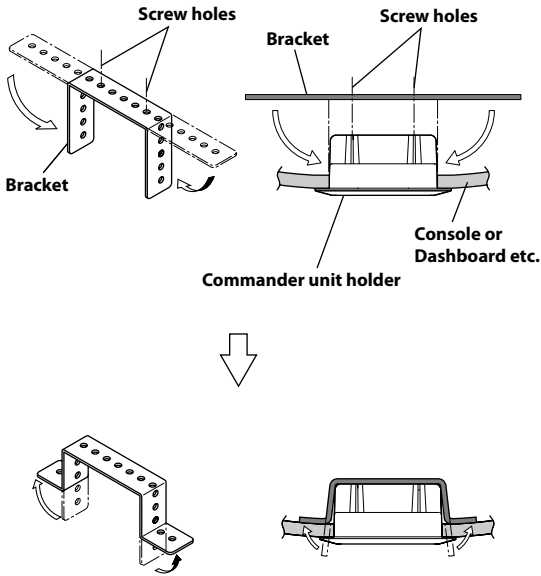

- To bend the bracket ③, it is recommended to use a vise or pliers.
- Use the appropriate screw holes of the bracket according to the shape of the vehicle installation position (i.e., console or dashboard).

- 5** Run the connector plug of the Commander cable through the hole of the Commander unit holder ②.

\* With the plug claw facing up, run the plug through the hole diagonally (as shown below).

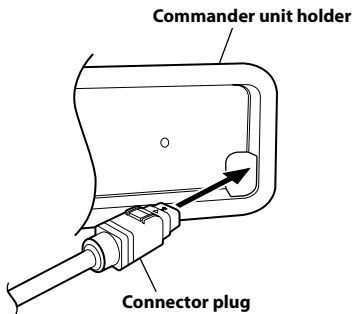

- 6** Tightly fix the Commander unit to the Commander unit holder ② with the provided 2 binding screws (M3 × 6 mm) ④ and apply Adhesive sheets (b) and (c) to the predetermined unit holder mounting positions.

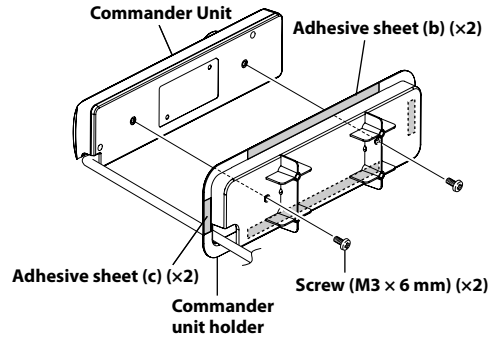

- 7** Install the Commander unit from step 6 above in the installation position.

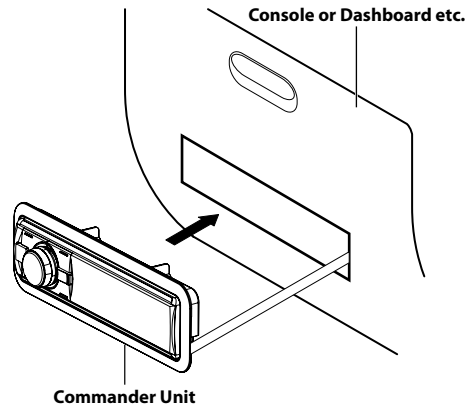

**CAUTION**

Doing so forcibly may break the plug.



- 8** Affix the Commander unit holder ② tightly using the 4 Adhesive sheets (d) ⑥ and 4 self-tapping screws (M4 × 14 mm) ⑤.

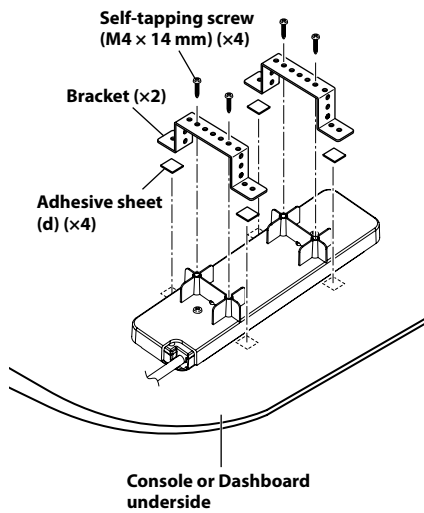

**CAUTION**

Make sure the Commander unit is tightly affixed. If any screws are loose, the Commander unit can rattle or fall while driving.

# Connections

## Left side

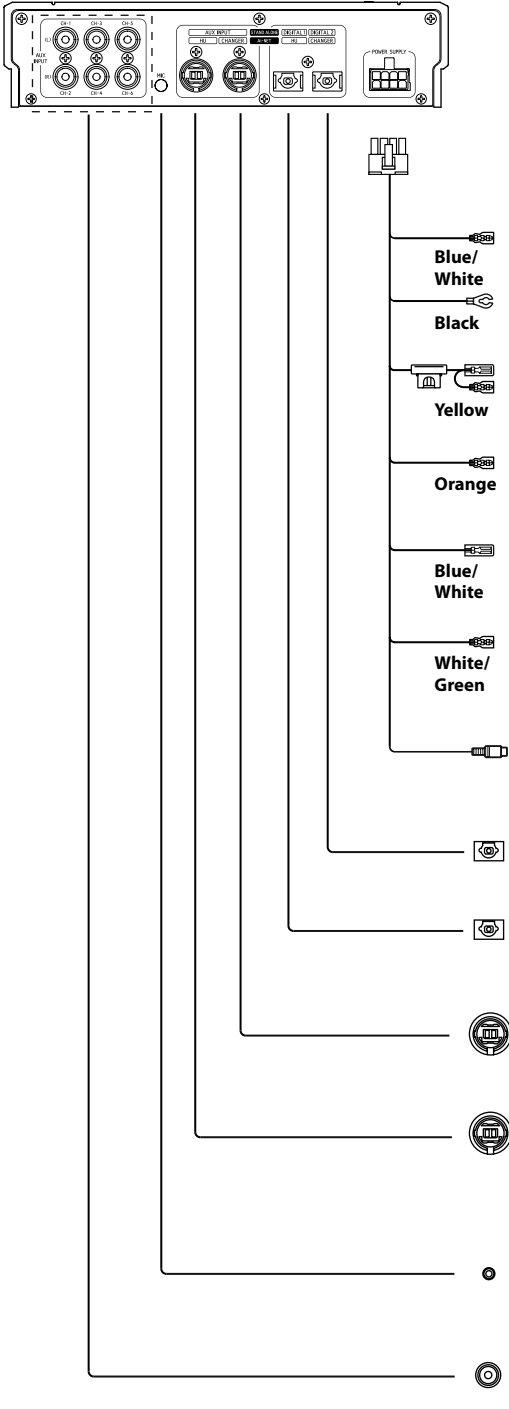

Cord colors and cord/terminal specifications	Connect to:
<b>Remote On Lead (REM IN) *1</b> Connect to the head unit for RCA connections. (Non Ai-NET connection)	Connect to the Remote On cord of the head unit.
<b>Ground Lead (GND)</b> Connect securely to a metal part of the vehicle's body.	Connect to the vehicle's body.
<b>Battery power Lead (BATT)</b> Power is supplied constantly to the PXA-H800 regardless of whether the engine key is on or off.	Connect this lead to the positive(+) post of the vehicle's battery.
<b>Illumination Lead (ILLM)</b> This lead may be connected to the vehicle's instrument cluster illumination lead. This will allow the backlighting of the RUX-C800 (sold separately) to dim whenever the vehicle's lights are turned on.	To the instrument cluster illumination lead. Use if the RUX-C800 (sold separately) is connected.
<b>Remote Out Lead (REM OUT)</b> Connect to the amplifier or other peripheral device.	Connect to the Remote On Lead of an amplifier.
<b>Guide control Lead (GUIDE)</b> Used to interrupt the navigation system's sound.	Connect to the Guide Control Lead of GUIDE SIGNAL I/F FOR EXTERNAL NAVIGATION (KCE-900E) (sold separately).
<b>Navigation audio input connector (RCA input) (NAVI)</b> Used to input the audio output signals of a navigation system.	Connect to the Guide output terminal of GUIDE SIGNAL I/F FOR EXTERNAL NAVIGATION (KCE-900E) (sold separately).
<b>Changer input terminal (optical digital input)</b> Used when connecting an Optical Digital compatible Changer, etc.	Connect to an Optical Digital compatible product with a optical fiber cable.
<b>Head unit input terminal (optical digital input)</b> Used when connecting an Optical Digital compatible Head Unit, etc.	Connect to an Optical Digital compatible product with a optical fiber cable.
<b>Changer input terminal (Ai-NET input) *2</b> Used for system expansion (Ai-NET changer, etc.).	Connect to an Ai-NET product using an Ai-NET cord. For connection to the PXA-H800, use the straight side.
<b>Head unit input terminal (Ai-NET input) *2</b> Used for system expansion (Head unit, etc.).	Connect to an Ai-NET product using an Ai-NET cord. For connection to the PXA-H800, use the straight side.
<b>Microphone jack</b> Use when implementing an automatic measurement of the automobile interior acoustics (ImprintEQ/Auto TCR) or when implementing an automatic adjustment of EQ characteristics (RoadEQ) along with the quantity of road noise while driving.	Connect to the microphone (included)
<b>Audio input jacks (RCA inputs) *3</b> Used to input the audio output signals of a head unit connected with RCA connections to the PXA-H800.	Used for RCA connections. Connect to the head unit.

\*1 If connecting to a system without the Remote On cord (such as a factory system), connect to an incoming power supply cord (accessory power) in the ACC position.

\*2 With Ai-NET/RCA Interface cable (KCA-121B) (sold separately), a television or video player with RCA audio output can be input to the device. For details, refer to "System Example" (page 10).

\*3 The allocation patterns for the device's audio input (RCA input) are the following 3 patterns.

RCA Input Pattern	AUX INPUT					
	CH-1 (L)	CH-2 (R)	CH-3 (L)	CH-4 (R)	CH-5 (L)	CH-6 (R)
5.1ch Input	AUX1					
	FL (Front Left)	FR (Front Right)	RL (Rear Left)	RR (Rear Right)	C (Center)	SubW (Subwoofer)
4ch&2ch Input	AUX1				AUX2	
	FL (Front Left)	FR (Front Right)	RL (Rear Left)	RR (Rear Right)	L (Left)	R (Right)
2chx3 Input	AUX1		AUX2		AUX3	
	L (Left)	R (Right)	L (Left)	R (Right)	L (Left)	R (Right)

- For details on how to set the RCA input pattern, refer to “Setting the AUX Input System (AUX Input System Select)” in the Owner’s Manual – PC guide, or “Setting the AUX Input System (AUX Input Setup)” in the Owner’s Manual – Commander guide.
- If connecting to an Ai-NET Head Unit/AV Head Unit, RCA input (AUX INPUT) connection is not available.
- For details on each “AUX INPUT” input pattern, refer to “System Example” (page 12).

## ■ Right side

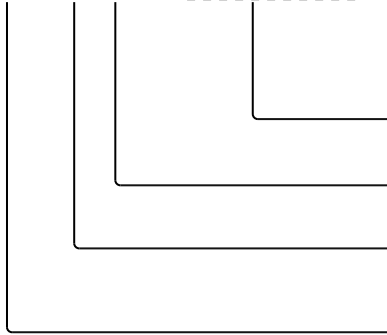
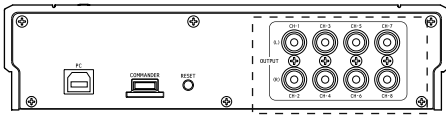

terminal specifications	Connect to:
<b>Audio output jacks(RCA output) *</b> Outputs an audio signal	Connect to amplifier
<b>RESET switch</b> The system of this unit is reset.	–
<b>Commander connection terminal</b> Use when operating this unit from the RUX-C800 (sold separately).	Connect to the RUX-C800 (sold separately).
<b>Computer connection terminal (USB terminal)</b> Use when operating this unit via a computer.	Connect to a computer with the USB cable accessory.

\* The location of the connection to the external amp for the audio output terminal (RCA output) varies, as specified below, depending on the connected speaker system.

Speaker System	CH-1(L)	CH-2(R)	CH-3(L)	CH-4(R)	CH-5(L)	CH-6(R)	CH-7(L)	CH-8(R)
F-2way+R+SW (4.2ch system)	Front2Way				Rear		Subwoofer	
	Front High(L)	Front High(R)	Front Low(L)* <sup>1</sup>	Front Low(R)* <sup>1</sup>	Rear(L)	Rear(R)	Subwoofer(L)* <sup>2</sup>	Subwoofer(R)* <sup>2</sup>
F-3way+SW (2.2ch system)	Front3Way						Subwoofer	
	Front High(L)	Front High(R)	Front Mid(L)* <sup>1</sup>	Front Mid(R)* <sup>1</sup>	Front Low(L)	Front Low(R)	Subwoofer(L)* <sup>2</sup>	Subwoofer(R)* <sup>2</sup>
F-3way+R (4.0ch system)	Front3Way						Rear	
	Front High(L)	Front High(R)	Front Mid(L)* <sup>1</sup>	Front Mid(R)* <sup>1</sup>	Front Low(L)	Front Low(R)	Rear(L)	Rear(R)
F-2way+R+C+SW (5.1ch system)	Front2Way				Rear		Center	Subwoofer
	Front High(L)	Front High(R)	Front Low(L)* <sup>1</sup>	Front Low(R)* <sup>1</sup>	Rear(L)	Rear(R)	Center	Subwoofer

- For details on how to set the speaker system, refer to “Setting the Speaker System (Output System Select)” in the Owner’s Manual – PC guide, or “Setting the Speaker System (System Select)” in the Owner’s Manual – Commander guide.

\*<sup>1</sup> An OFF setting is not available.

\*<sup>2</sup> If connecting 2 subwoofers, the subwoofer output can be set to stereo or monaural output. If connecting a subwoofer, set the subwoofer output (Subwoofer 2) to “OFF.” For details, refer to “Setting the Speaker System (Output System Select)” in the Owner’s Manual – PC guide, or “Setting the Speaker System (System Select)” in the Owner’s Manual – Commander guide.

## ■ Speaker System Example

F-2way+R+SW(4.2ch System)

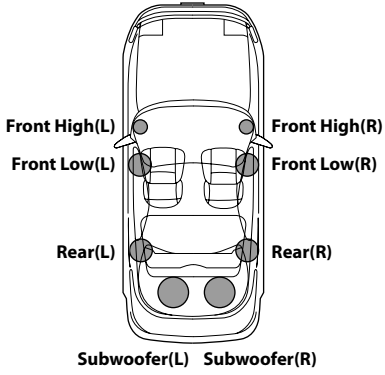

F-3way+SW(2.2ch System)

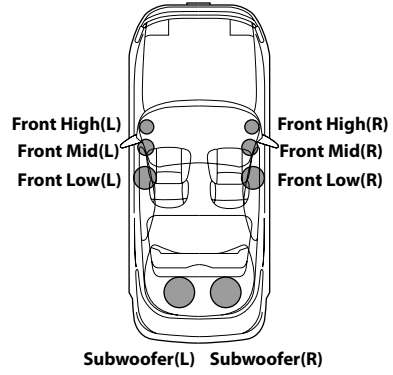

F-3way+R(4.0ch System)

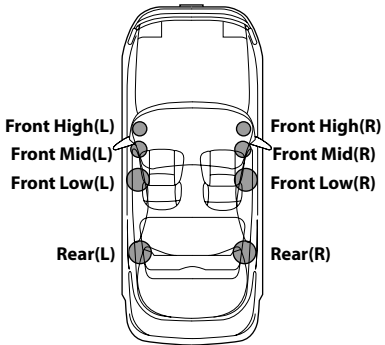

F-2way+R+C+SW(5.1ch System)

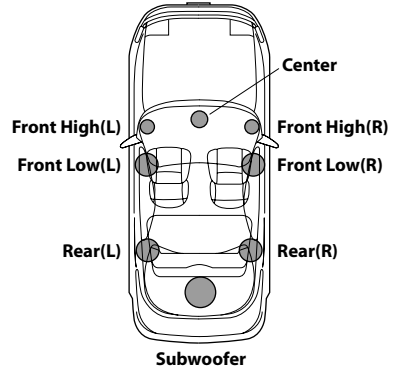

# System Example

## Connecting an automobile factory system (standard audio, etc.) and External Amplifier

### ■ Input Pattern: 4ch&2ch Input

AUX INPUT					
CH-1 (L)	CH-2 (R)	CH-3 (L)	CH-4 (R)	CH-5 (L)	CH-6 (R)
AUX1			AUX2		
FL (Front Left)	FR (Front Right)	RL (Rear Left)	RR (Rear Right)	L (Left)	R (Right)

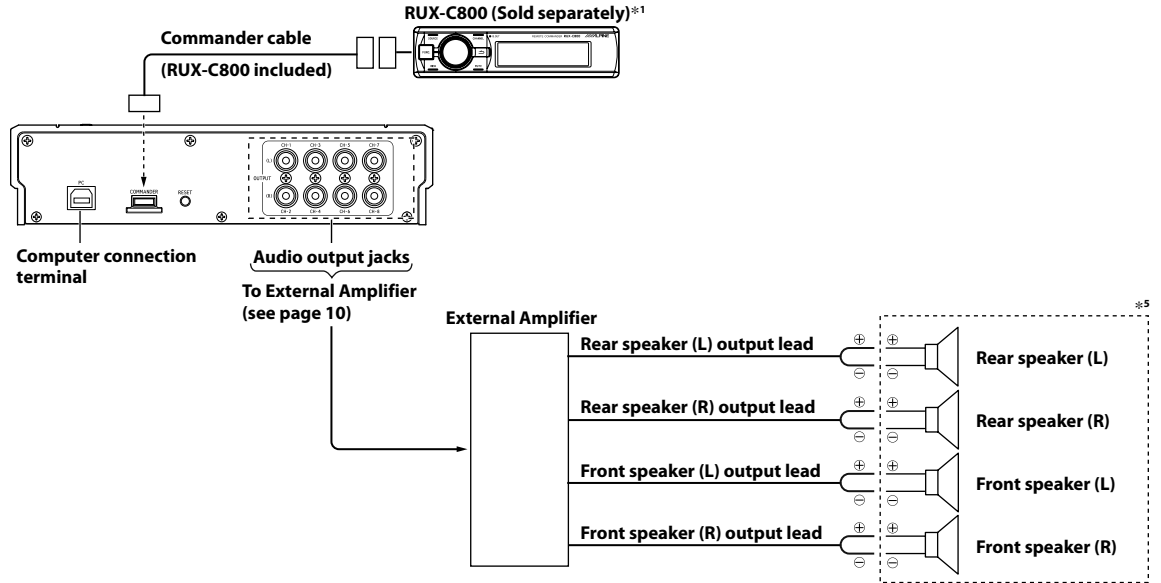

\*1 When using a factory car audio system, the RUX-C800 Commander (sold separately) is required.

\*2 If your factory system does not have a Remote Turn-On Lead, connect a cable that enables an incoming power supply (accessory power) in the ACC position.

\*3 If using the Speaker-RCA Conversion cable, up to 6 channels can be input. Make connections according to your system.

\*4 Before using the Speaker-RCA Conversion cable, remove the cord tip coating, cut the cord into 2 cables, connect the cable with commercially available bullet or solderless terminals attached to the tips.

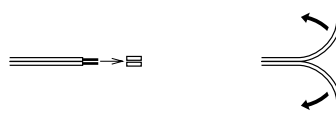

\*5 When connecting a speaker input cable, connect via a solderless terminal or solderless connector after disconnecting the automobile's speaker cable.

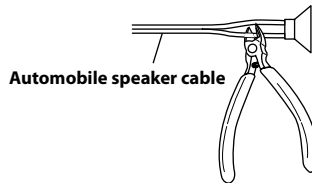

### ⚠ CAUTION

Make sure to disconnect the factory speakers and the speaker output cable for the factory system.

When using fiber cable, follow the guidelines below:

- When laying or bundling optic fiber cables, the minimum bending radius should be 30 mm. Bending beyond the radius will break the cable, resulting in no digital sound being output.
- Do not put the product or other items on the optic fiber cable.

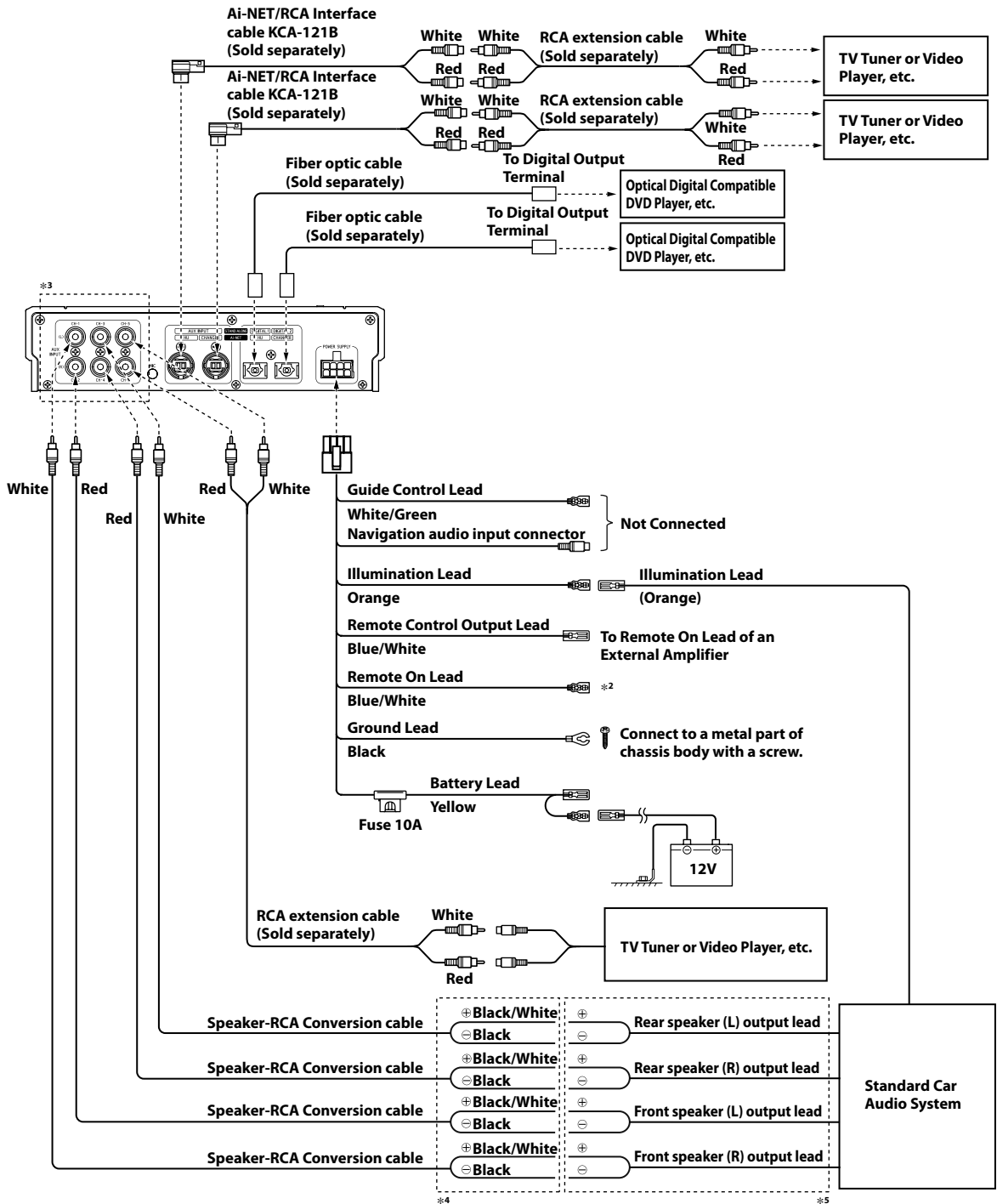

# Connecting a Non Ai-NET AV Head Unit, External Input and External Amplifier

## Input Pattern : 5.1ch Input

AUX INPUT					
CH-1 (L)	CH-2 (R)	CH-3 (L)	CH-4 (R)	CH-5 (L)	CH-6 (R)
AUX1					
FL (Front Left)	FR (Front Right)	RL (Rear Left)	RR (Rear Right)	C (Center)	SubW (Subwoofer)

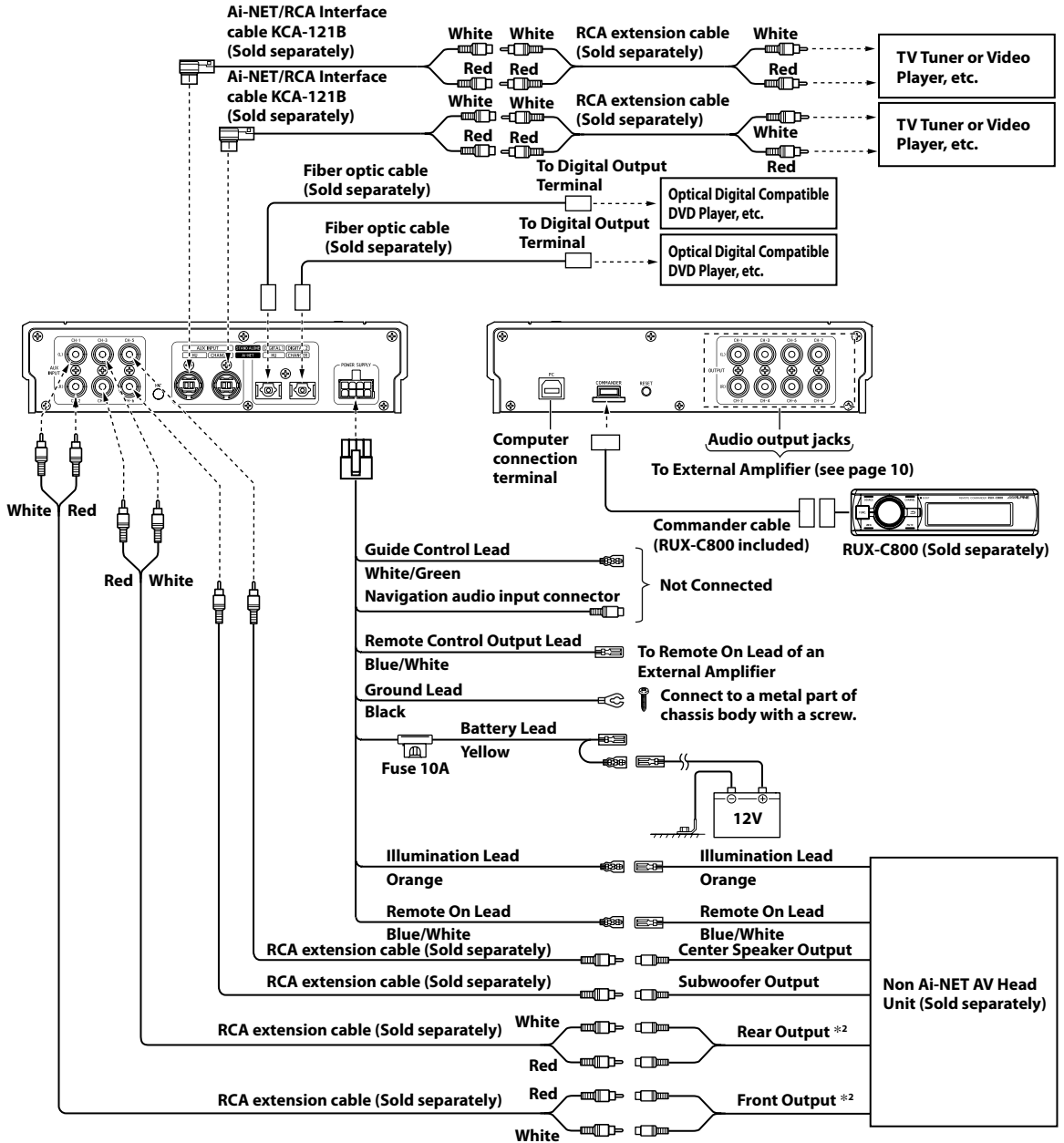

\*1 When using a head unit that is not Ai-NET compatible, the RUX-C800 Commander (sold separately) is required.

### CAUTION

When using fiber cable, follow the guidelines below:

- When laying or bundling optic fiber cables, the minimum bending radius should be 30 mm. Bending beyond the radius will break the cable, resulting in no digital sound being output.
- Do not put the product or other items on the optic fiber cable.



# Connecting a Non Ai-NET Head Unit, External Input and External Amplifier

## Input Pattern : 2ch×3 Input

AUX INPUT					
CH-1 (L)	CH-2 (R)	CH-3 (L)	CH-4 (R)	CH-5 (L)	CH-6 (R)
AUX1		AUX2		AUX3	
L (Left)	R (Right)	L (Left)	R (Right)	L (Left)	R (Right)

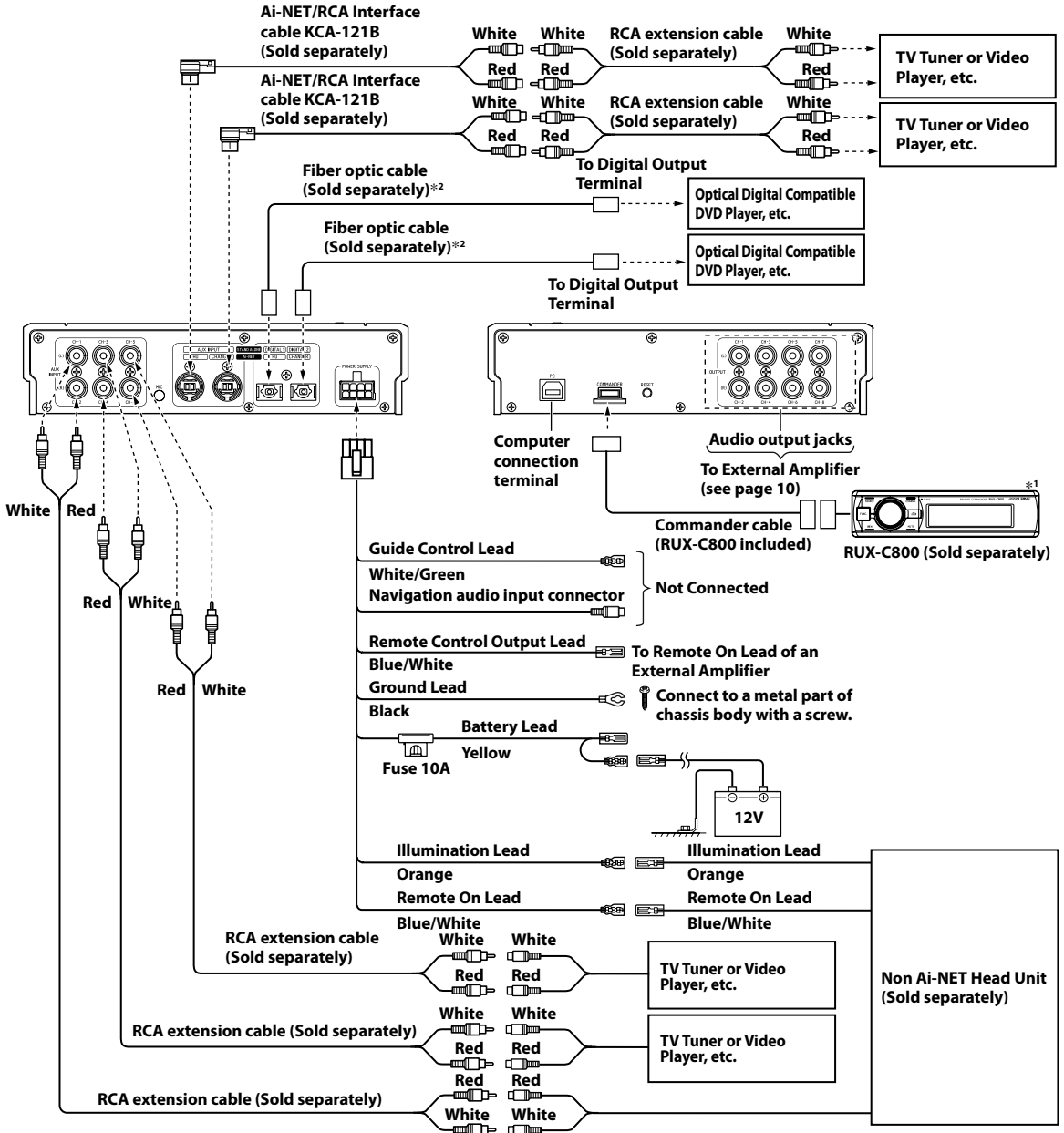

\*1 When using a head unit that is not Ai-NET compatible, the RUX-C800 Commander (sold separately) is required.

\*2 Use when connected with an Optical Digital compatible Unit.

### CAUTION

When using fiber cable, follow the guidelines below:

- When laying or bundling optic fiber cables, the minimum bending radius should be 30 mm. Bending beyond the radius will break the cable, resulting in no digital sound being output.
- Do not put the product or other items on the optic fiber cable.

# Connecting an Ai-NET compatible AV Head Unit (INA-W910), ALPINE Navigation System, Ai-NET compatible Changer and External Amplifier

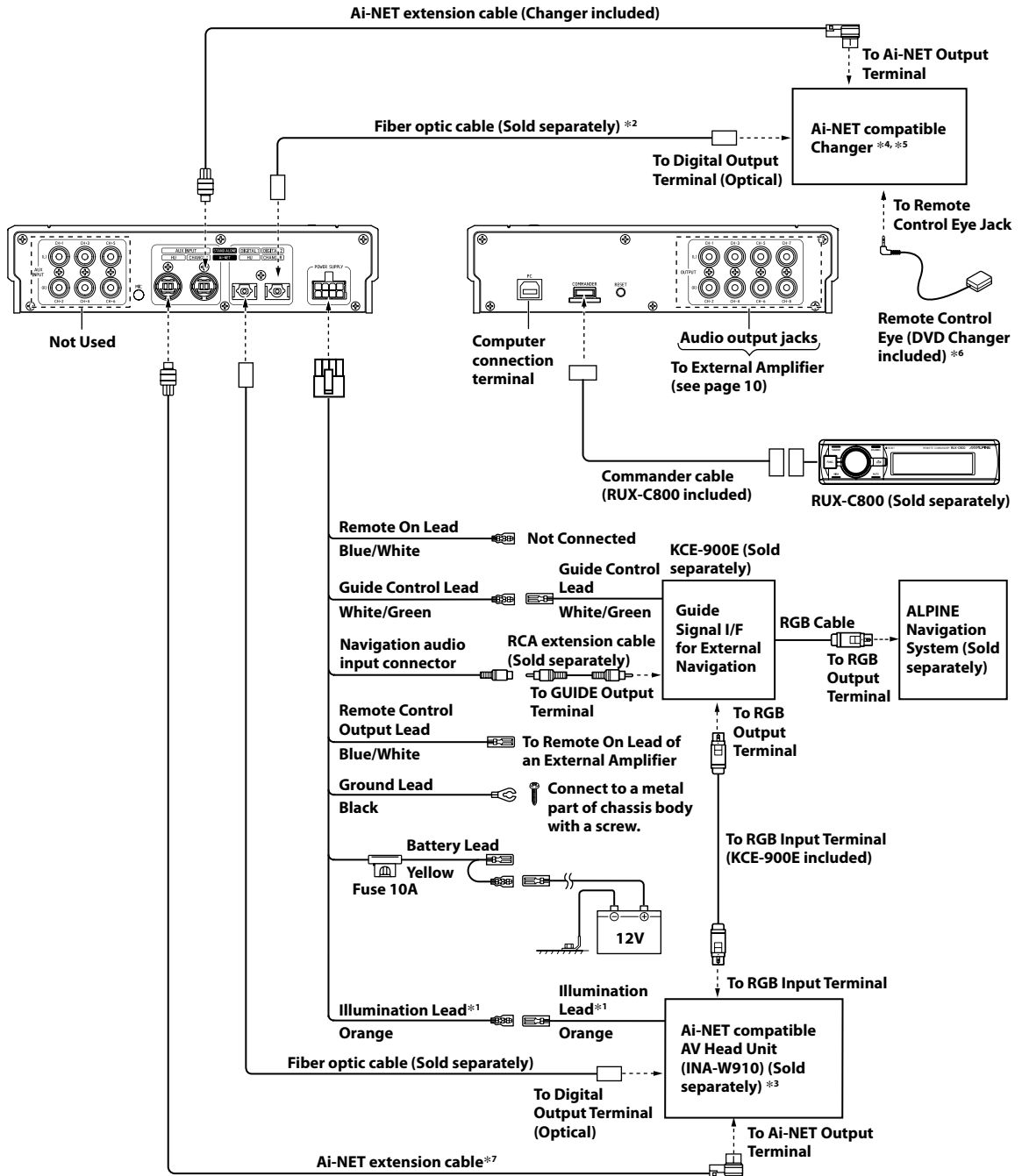

\*1 Use when connected with the RUX-C800 Commander (sold separately).

\*2 Use when connected with an Optical Digital compatible Changer.

\*3 Set the system switch to [EQ/DIV] or [EXT AP]. For details, refer to the Owner's Manual for the product connected.

\*4 Setting the system switch is required. For details, refer to the Owner's Manual for the connected changer.

\*5 If the Ai-NET compatible Changer is a DVD Changer (DHA-S690 Series or DHA-S680 Series), do not connect its Switched Power Lead (Red).

\*6 If the Ai-NET compatible Changer is a DVD Changer (DHA-S690 Series or DHA-S680 Series), do not connect the Remote Control Eye in a system that uses an Ai-NET compatible AV Head Unit. (Connection of the remote input cord (white/brown) is required.) Use the Remote Control Eye in a system that uses any other manufacturer's monitor. For details, refer to the connected DVD changer's instruction manual.

\*7 If connecting DVA-5210, connect it between the unit and the head unit using an additional Ai-NET extension cable. In this case, also connect the audio output jacks (L=white/R=red) of DVA-5210 to the AUX INPUT CH-1 (L)/CH-2 (R) jacks of the unit.



## **CAUTION**

**When using fiber cable, follow the guidelines below:**

- **When laying or bundling optic fiber cables, the minimum bending radius should be 30 mm. Bending beyond the radius will break the cable, resulting in no digital sound being output.**
- **Do not put the product or other items on the optic fiber cable.**

# Connecting an Ai-NET compatible Head Unit, Ai-NET compatible Changer and External Amplifier

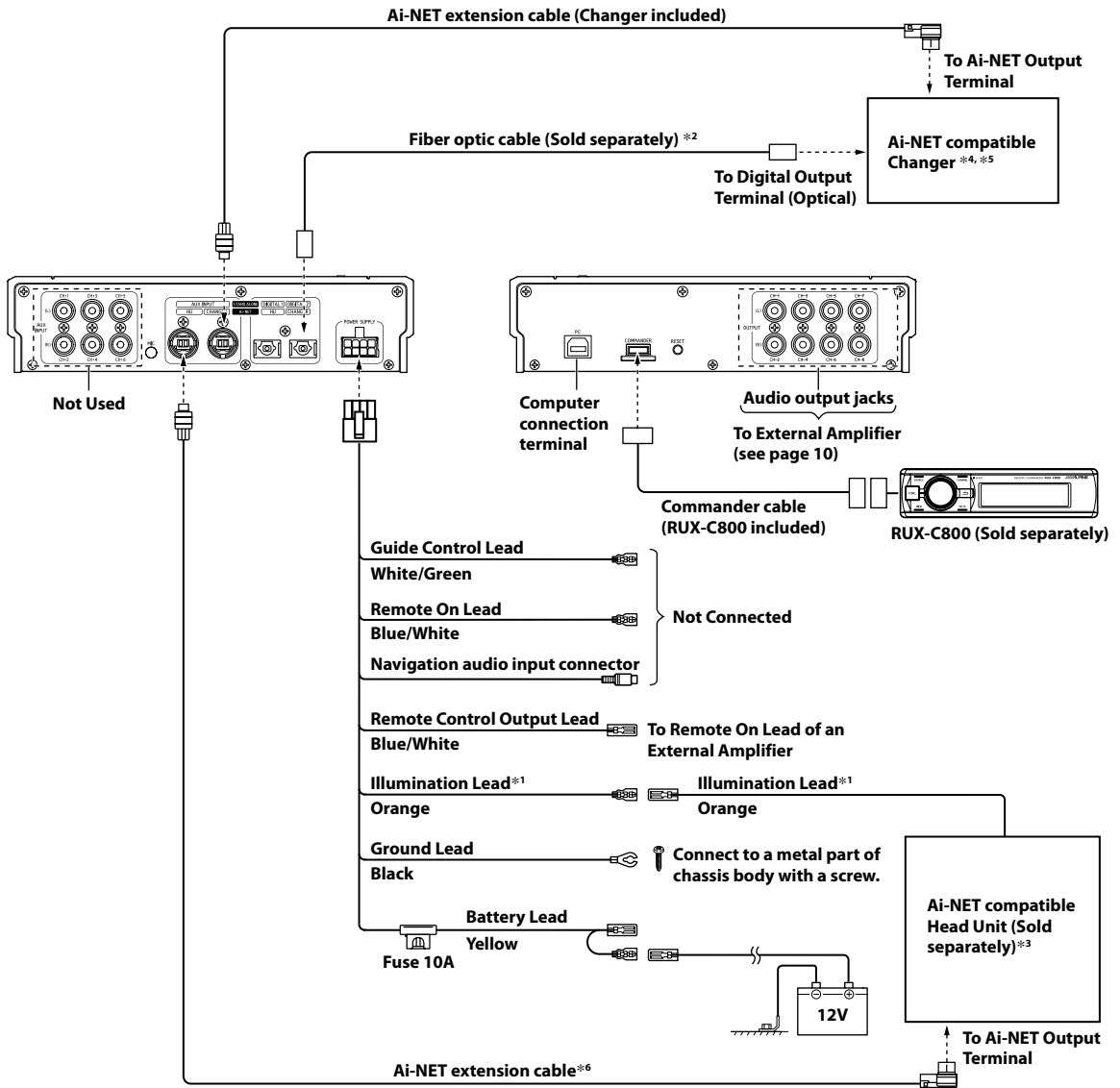

\*1 Use when connected with the RUX-C800 Commander (sold separately).

\*2 Use when connected with an Optical Digital compatible Changer.

\*3 Checking and setting of the system switch are required. For details, refer to the Owner's Manual for the product connected.

\*4 If connecting with an Optical Digital compatible Changer, setting the system switch is required. For details, refer to the Owner's Manual for the connected changer.

\*5 If the Ai-NET compatible Changer is a DVD Changer (DHA-S690 Series or DHA-S680 Series), do not connect its Switched Power Lead (Red).

\*6 If connecting DVA-5210, connect it between the unit and the head unit using an additional Ai-NET extension cable. In this case, also connect the audio output jacks (L=white/R=red) of DVA-5210 to the AUX INPUT CH-1 (L)/CH-2 (R) jacks of the unit.

## CAUTION

When using fiber cable, follow the guidelines below:

- When laying or bundling optic fiber cables, the minimum bending radius should be 30 mm. Bending beyond the radius will break the cable, resulting in no digital sound being output.
- Do not put the product or other items on the optic fiber cable.

---

## Confirmation

---

### **1 Securing leads, etc.**

Make sure leads are not pinched by moving such as the seat rail, etc. Also check for damaged from sharp edges or protrusion.

### **2 Connect the battery (-) terminal.**

### **3 Turn on the engine key. Make sure the unit operating correctly by referring to the Owner's Manual.**

Check the Owner's Manuals for the connected products as well.

### **4 Make sure all factory components such the brake lamps, etc. work correctly.**