

# Ultra<sup>®</sup> 870 Dispenser

## User's Guide



Electronic pdf files of EFD manuals are also available at [www.efd-inc.com/manuals.html](http://www.efd-inc.com/manuals.html)

## Ultra 870

**EFD**<sup>®</sup>  
A NORDSON COMPANY

Welcome to the Ultra 870 User's Guide, designed to help you maximize the usefulness of your new dispenser.

Please spend a few minutes to become familiar with the controls and features. Follow our recommended testing procedures. Review the helpful information we have included, which is based on more than 30 years of industrial dispensing experience.

Most questions you will have are answered in this guide. However, if you need assistance, please do not hesitate to contact EFD or your authorized EFD distributor.

In the USA, call 800-556-3484 between 8:30 a.m. and 5:30 p.m. Eastern time.

In Europe, call +44 (0) 1582 666334.

In Asia, call +86 (21) 5854 2345.

In all other areas, call your authorized EFD distributor or +1-401-434-1680.

---

### **The EFD Pledge**

We pledge that you will be completely satisfied with our products. We endeavor to ensure that every EFD product is produced to our no-compromise quality standards.

If you feel that you are not receiving all the support you require, or if you have any questions or comments, I invite you to write or call me personally.

Our goal is to build not only the finest equipment and components, but also to build long-term customer relationships founded on superb quality, service, value and trust.

Peter Lambert, President

---

Safety ..... 4

Specifications ..... 6

Getting Started ..... 7-9

Features and Controls ..... 10-11

Vacuum Control ..... 12

Filling the Syringe Barrel ..... 13  
    Syringe Barrel Loaders ..... 14

Test Procedures ..... 15

Schematic / Parts List ..... 16

Troubleshooting ..... 17

Helpful Hints ..... 18

Productivity Tools ..... 19

Warranty ..... Back Cover

## Introduction

Read and follow these safety instructions. Task- and equipment-specific warnings, cautions and instructions are included in equipment documentation where appropriate.

## Qualified Personnel

Equipment owners are responsible for making sure that EFD equipment is installed, operated and serviced by qualified personnel. Qualified personnel are those employees or contractors who are trained to safely perform their assigned tasks. They are familiar with all relevant safety rules and regulations, and are physically capable of performing their assigned tasks.

## Intended Use

Use of EFD equipment in ways other than those described in the documentation supplied with the equipment may result in injury to persons or damage to property.

Some examples of unintended use of equipment include

- Using incompatible materials
- Making unauthorized modifications
- Removing or bypassing safety guards or interlocks
- Using incompatible or damaged parts
- Using unapproved auxiliary equipment
- Operating equipment in excess of maximum ratings

## Regulations and Approvals

Make sure all equipment is rated and approved for the environment in which it is used. Any approvals obtained for EFD equipment will be voided if instructions for installation, operation and service are not followed.

## Personal Safety

To prevent injury follow these instructions.

- Do not operate or service equipment unless you are qualified.
- Do not operate equipment unless safety guards, doors or covers are intact and automatic interlocks are operating properly. Do not bypass or disarm any safety devices.
- Obtain and read Material Safety Data Sheets (MSDS) for all materials used. Follow the manufacturer's instructions for safe handling and use of materials, and use recommended personal protection devices.
- To prevent injury, be aware of less-obvious dangers in the workplace that often cannot be completely eliminated, such as hot surfaces, sharp edges and moving parts that cannot be enclosed or otherwise guarded for practical reasons.
- This equipment is for indoor use only.
- Always keep dispensing end of syringe barrel pointed away from your face and towards the work piece. Store the syringe barrel in an appropriate holder when not in use.

## **Fire Safety**

To avoid a fire or explosion, follow these instructions.

- Do not smoke, weld, grind or use open flames where flammable materials are being used or stored.
- Provide adequate ventilation to prevent dangerous concentrations of volatile particles or vapors. Refer to local codes or your material MSDS for guidance.
- Know where emergency stop buttons, shutoff valves and fire extinguishers are located.
- Clean, maintain, test and repair equipment according to the instructions in your equipment documentation.
- Use only replacement parts that are designed for use with original equipment. Contact your EFD representative for parts information and advice.

## **Action in the Event of a Malfunction**

If a system or any equipment in a system malfunctions, disconnect air supply from dispenser, and identify the reason for the malfunction and correct it before restarting the system.

## **Disposal**

Dispose of equipment and materials used in operation and servicing according to local and national codes.

## Specifications

Cabinet size: 13.3 W x 15.0 H x 15.2 D cm (5.25 x 5.94 x 6.00")

Weight: 0.95 kg (2.08 lb)

Cycle rate: Exceeds 600 cycles per minute

Air input: 80 to 100 psi (5.5 to 6.9 bar)

Air output: 0 to 100 psi (0 to 6.9 bar)

Note: Specifications and technical details are subject to change without prior notification.

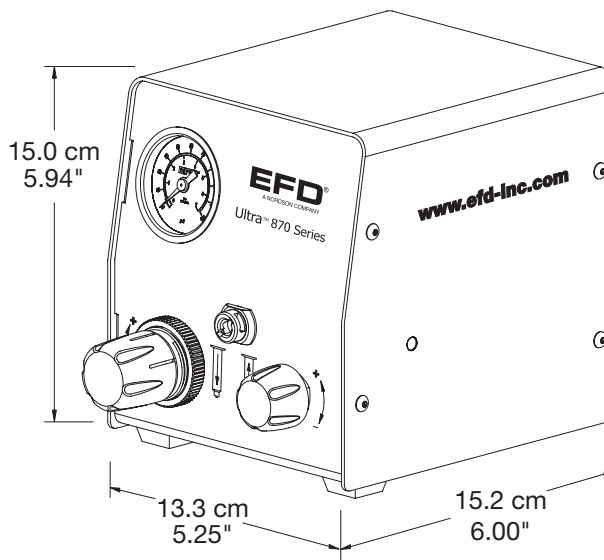

## Unpack the Unit / Warranty

# 1

- Unpack the unit.
- Now is a good time to activate your Two Year Warranty. Register the warranty online at [www.efd-inc.com/warranty/two](http://www.efd-inc.com/warranty/two). Or if you prefer, follow the instructions in the enclosed "Welcome" letter to contact your EFD representative.

## Install Barrel Holder

# 2

- Remove sleeve from barrel holder.
- Insert 6 mm screw through wire adapter hose holder, then through barrel holder ①.
- Tighten screw to secure holder to dispenser cover. Holder can be mounted left or right.
- Insert barrel holder sleeve.

Note: If you prefer, the wire adapter hose holder can be mounted on the opposite side of the cabinet, separately from the barrel holder.

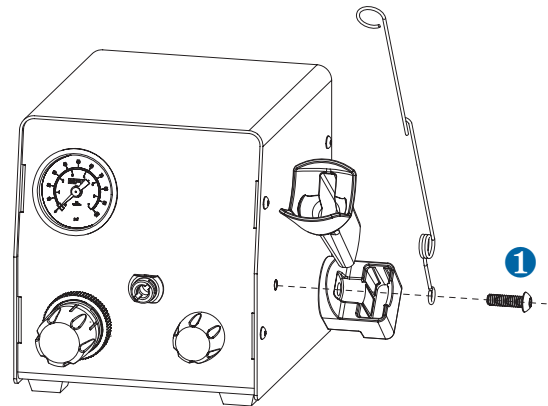

## Connect Air Input

# 3

Note: Clean, dry filtered factory air is required to meet warranty. If your air supply is not filtered, order the EFD five-micron filter regulator (EFD part #2000F755).

- Push one end of the 6 mm air input hose into the input fitting on the back of the Ultra 870.
- Connect the other end of the hose to your plant air supply. A standard 1/4-inch NPT fitting is included with your dispenser.
- Set plant air supply within 80 to 100 psi (5.5 to 6.9 bar).

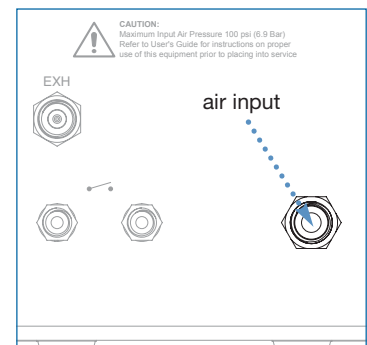

## Connect Foot Pedal

4

- Connect the foot pedal to the back of the Ultra 870. Push the white tubing into the white fitting; push the black tubing into the black fitting.

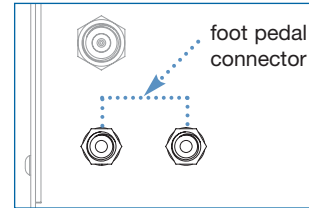

## Attach Syringe Barrel / Dispense Tip

5

- Attach an EFD syringe barrel filled with your fluid to the adapter assembly.
- Snap the safety clip on the adapter hose closed to prevent dripping. Remember to unsnap the clip when ready to dispense.
- Replace tip cap with an EFD precision dispense tip.
- Place syringe barrel in the barrel holder.

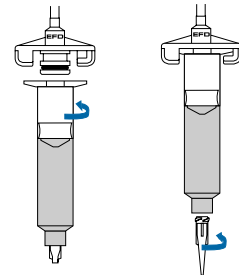

## Connect Air Output

6

- Push in the black, male quick-connect from the EFD adapter assembly provided into the front of the Ultra 870.
- Twist clockwise to lock.
- See page 15 for Initial Test Procedures.

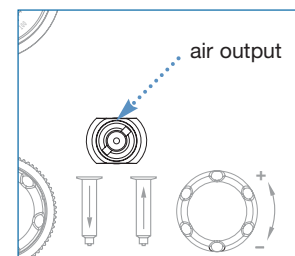



## Completed Setup

**Note:** Each number corresponds to the appropriate “Getting Started” step.

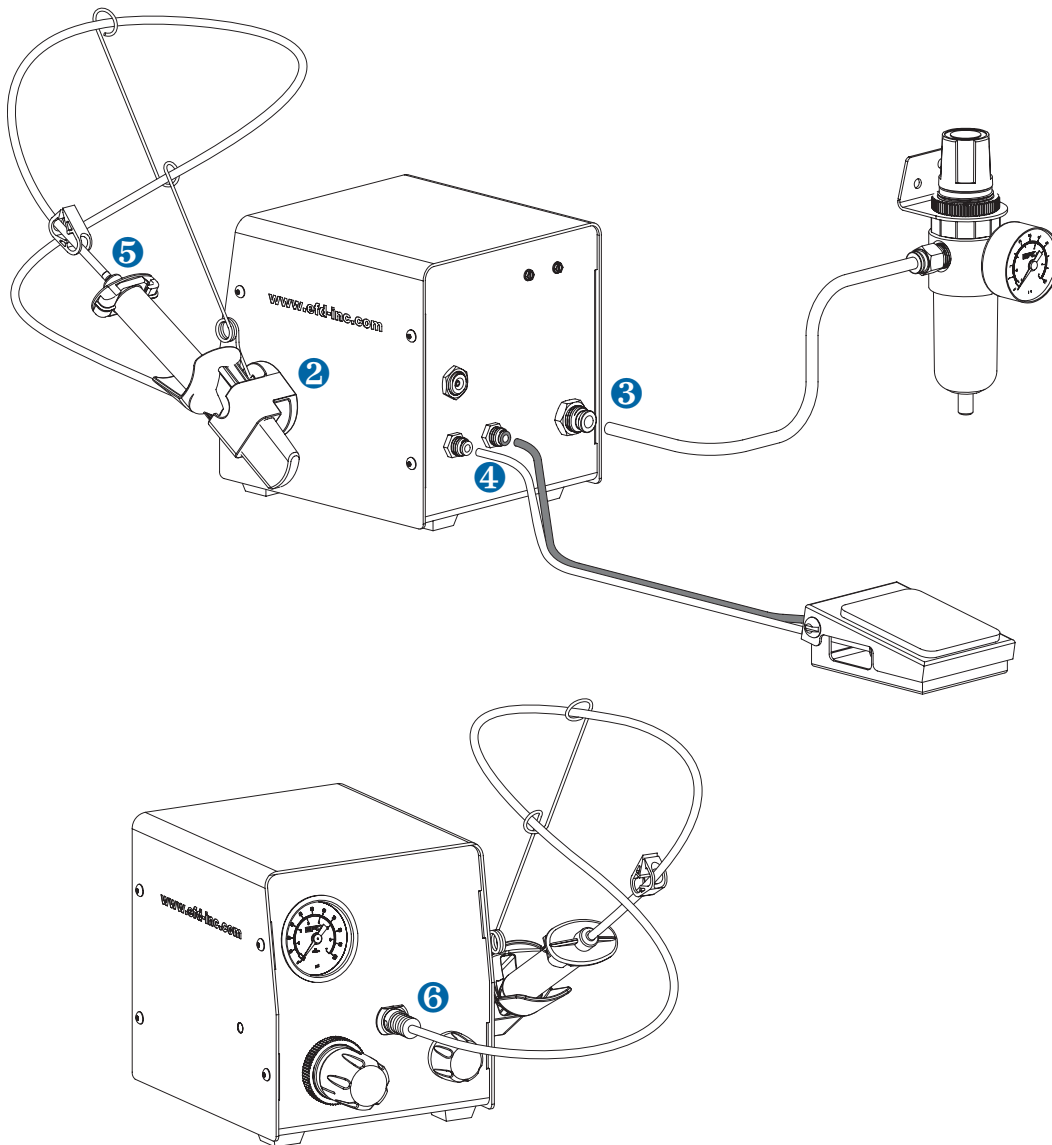

## Features & Controls: Front Panel

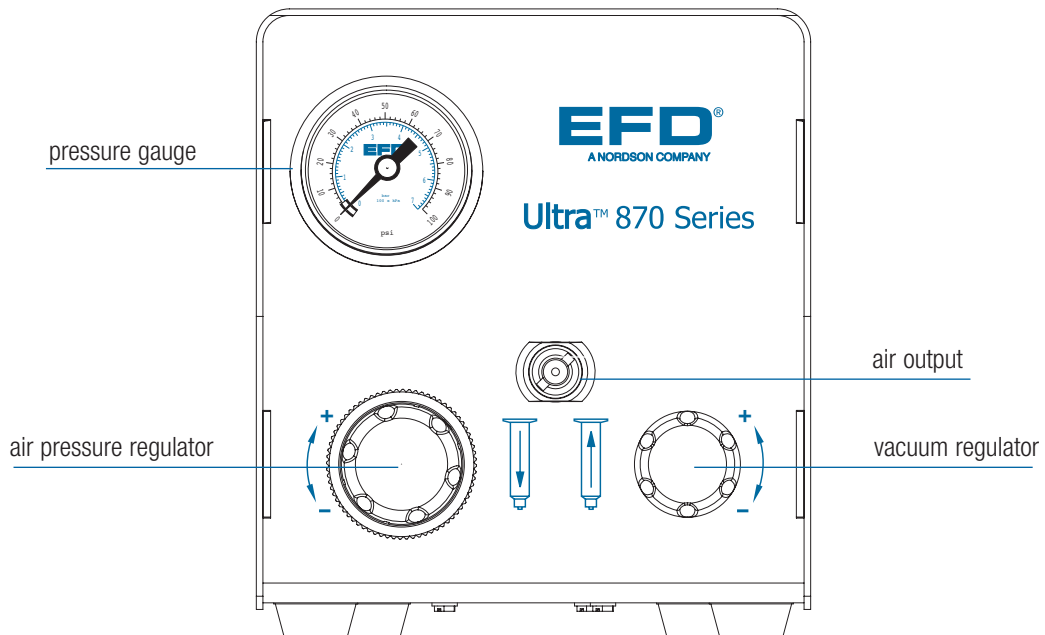

### Air Pressure

- Pull out the air pressure regulator knob to unlock it (bottom left knob).
- Turn the knob clockwise to the desired pressure setting.
- To reduce the pressure, turn the knob counter-clockwise until pressure is lower than needed. Then increase the pressure until you reach the correct setting.
- Push the knob in to lock the pressure setting.

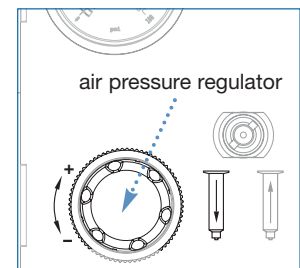

### Vacuum

During initial testing and setup we recommend that you keep the vacuum control shut off (turned completely clockwise; do not force).

Vacuum is required when dispensing thin fluids.

- Turn the knob counter-clockwise to the desired vacuum setting.

See page 12 for details on using the Vacuum control.

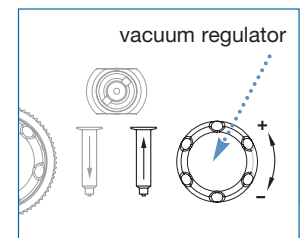

### Air Output Port

Push in the black quick-connect from the EFD adapter assembly to the air output port, located on the front of the Ultra 870. Twist to lock.

Note: air does not flow through the port until a quick-connect is installed.

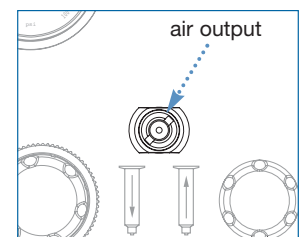

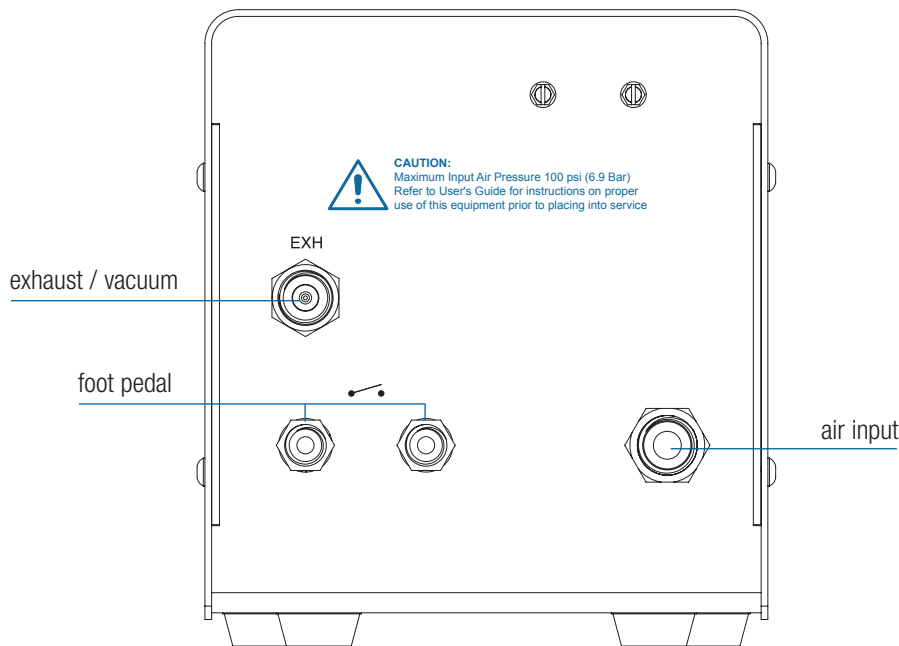

### Air Input Port

- Push one end of the 6 mm air input hose into the back of the Ultra 870. A standard air hose is provided.
- Connect the other end of the air input hose to your plant air supply.

Note: Clean, dry filtered factory air is required to meet warranty. If your air supply is not filtered, order the five-micron filter regulator (specify EFD part #2000F755).

**Warning!** Bottled nitrogen can be used. If high pressure bottled air or nitrogen is used, a high pressure regulator must be installed on the bottle and set at 100 psi (6.9 bar) maximum. In this instance, the 2000F755 filter regulator is not required.

### Foot Pedal

Connect the foot pedal provided to the port on the back of the Ultra 870. The foot pedal is used to activate the dispense cycle. The ports are color coded to the tubing from the foot pedal.

### Vacuum Transducer / Air Exhaust Port

The vacuum transducer and exhaust port is located on the back panel.

If needed you can connect a cleanroom filter muffler to filter output air to meet Fed 209-B (0.5 micron particulates). Specify EFD part #2170FT.

### Using Vacuum to Make Deposits of Watery-Thin Fluids

The Ultra 870 vacuum control allows low viscosity fluids, even water, to be consistently dispensed without dripping between cycles. A vacuum is exerted above the fluid in the barrel to prevent dripping. For medium to high viscosity fluids, the vacuum should be shut off.

If you are dispensing watery solvents, cyanoacrylates or anaerobics, request the blue LV Barrier™ piston and follow these steps to fill the syringe barrel and set the vacuum control.

1. Twist an orange tip cap onto an empty syringe barrel and pour your fluid in. Maximum fill is half full. Insert the blue LV Barrier piston. Allow an air gap between piston and fluid as shown. (If you are using the SmoothFlow™ piston, push the white piston down until it comes in contact with the fluid.)
2. Attach the syringe to the EFD adapter assembly.
3. Snap the safety clip tightly closed to prevent any dripping.
4. Remove the tip cap and attach a precision dispense tip.
5. Set air pressure at 5 psi (0.3 bar).
6. With the syringe barrel pointing down over a container, unsnap the safety clip. Press and hold the foot pedal to fill the tip.
7. As a drop begins to form at the end of the tip, slowly turn the vacuum regulator knob counter-clockwise to stop the drip. Wipe the tip and adjust vacuum as necessary.
8. Rest the tip on the Dot Standards sheet. Press the foot pedal and release. Check the dot size. Increase or decrease by adjusting pressure or time as needed.

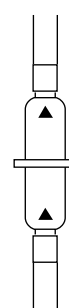
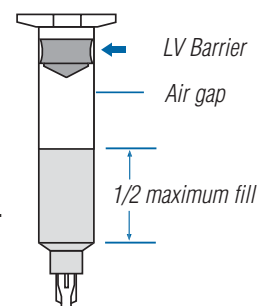

#### Helpful Hint

For low viscosity fluids, use an EFD filter trap (#1000FLT-Y). This filter trap will impede the flow should the liquid be sucked back towards the dispenser.

**Syringe Barrel Filling Techniques**

Caution: Do not completely fill syringe barrels. The optimum fill is a maximum 2/3 of the barrel capacity and 1/2 of the barrel capacity when using the EFD blue LV Barrier piston.

For best results, we strongly recommend that you use a piston as part of your dispensing system. The white EFD SmoothFlow piston is appropriate for most fluids and has several advantages.

- First, vacuum adjustment is less sensitive.
- Second, the piston prevents fumes from the fluid being exhausted into the work environment.
- Third, the piston prevents fluid backflow into the dispenser if the syringe barrel is inadvertently turned upside down.
- Fourth, the piston makes it easy and safe to change tips without dripping.

**Remember**  
 For best results, EFD strongly recommends the use of a piston as part of your dispensing system.

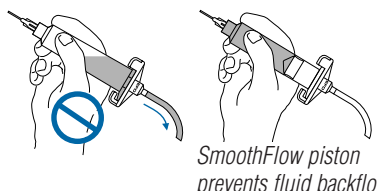

SmoothFlow piston prevents fluid backflow.

Fumes cannot escape. No air gap when using the SmoothFlow piston.

If you choose to not use a piston when dispensing thin fluids, remember these important points.

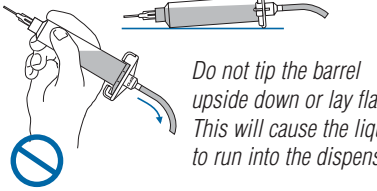

Do not tip the barrel upside down or lay flat. This will cause the liquid to run into the dispenser.

**Open** When changing tips or attaching a tip cap, snap the safety clip completely closed to prevent any dripping or bubbling.

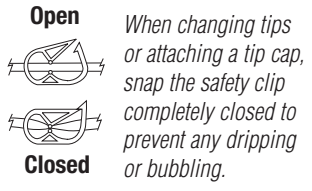

**Closed**

For watery solvents and cyanoacrylates, request the blue EFD LV Barrier piston, available in 3cc and 10cc sizes. If you are dispensing an RTV silicone and find that the piston bounces and causes stringing, request the EFD orange, flat wall piston.

**Filling procedure for pourable low and medium viscosity fluids**

If the fluid you are dispensing is pourable, take the syringe barrel, twist on an orange tip cap and pour your fluid in. Insert a white SmoothFlow piston and carefully press down until it contacts the fluid. The syringe barrel is now ready for use.

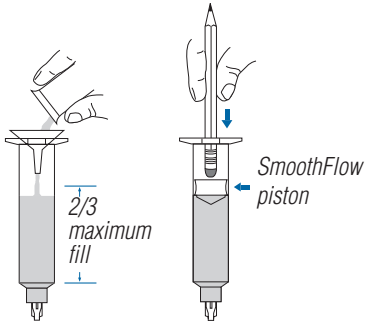

**Filling procedure for thick fluids**

If your fluid is thick or non-leveling, you can spoon it into the syringe barrel with a spatula. Or, if the fluid comes packed in a 1/10 gallon (300 ml) cartridge, try loading the barrel with a caulking gun. Then, press the SmoothFlow piston to move the fluid to the bottom of the syringe barrel and remove trapped air.

Trapped air in thick fluids can lead to drooling and oozing. Also, repetitive air cycles can bore tunnels through non-leveling fluids, causing spitting and inconsistent deposits. The SmoothFlow piston eliminates these problems. It prevents tunneling by providing a barrier to the pulsed-air cycles. And it prevents oozing by responding to the pressure of trapped air with a slight suck-back movement after the dispense cycle.

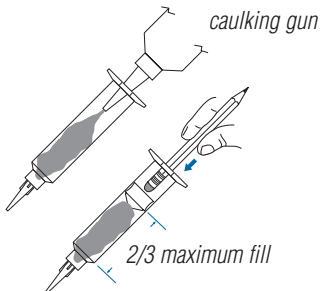

## Barrel Loading Alternatives

EFD offers productive alternatives to traditional syringe barrel loading methods. Here are a few suggestions that can help keep your work area clean, save time and reduce the chance of entrapped air in the fluid.

1. You could use the EFD #920BL barrel loader. Pack the fluid into the 12 ounce cartridge as shown. Then place the pre-filled cartridge into the barrel loader. Using air pressure, the barrel loader fills the syringe barrel (with a piston installed) from the bottom up.  
If the fluid comes packed in a 1/10 gallon (300 ml) caulking type cartridge, use the EFD #940BL barrel loader.
2. For fast, accurate volumetric filling, the 8000BF Barrel Filling Station can be used with any pressure reservoir or cartridge. Recommended for high production barrel filling.
3. If you receive frozen epoxies or other fluids in medical type syringes with a manual plunger, request the EFD luer-to-luer fitting #2160 to transfer the material.

Please contact an EFD Fluid Application Specialist for additional assistance.

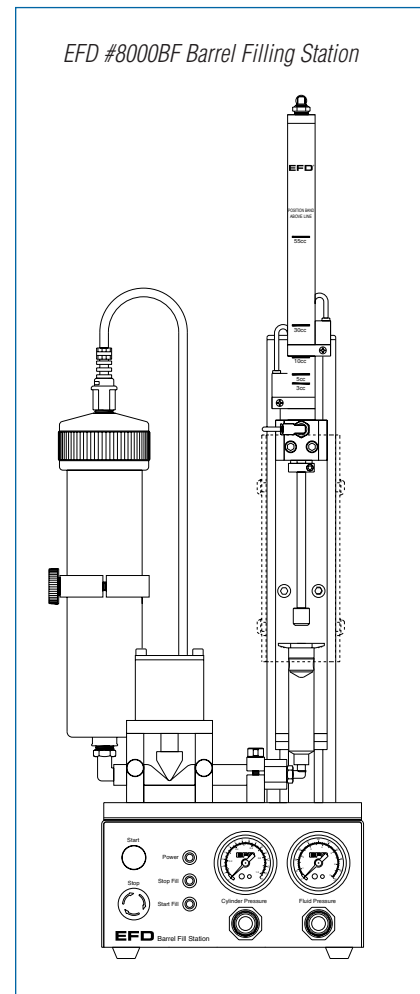
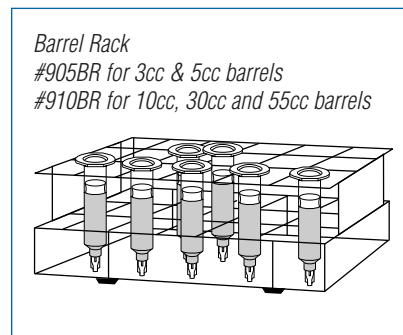
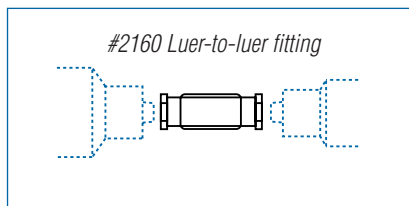
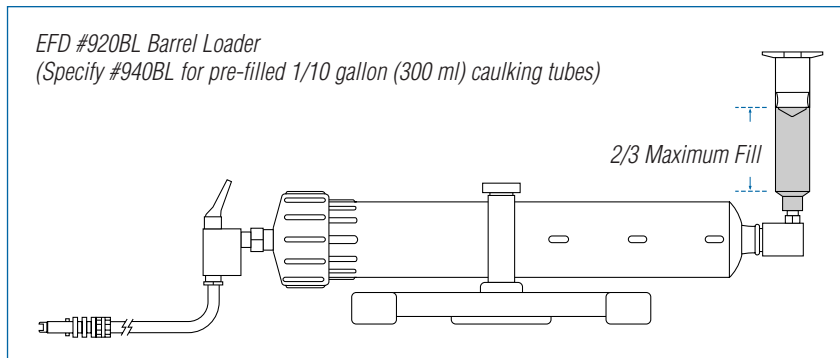

Deposit size is controlled by how long you press the foot pedal, pressure and tip size.

Please follow these instructions to test the Ultra 870 functions. Use the convenient Dot Standards sheet included in your dispensing kit.

1. Attach an EFD syringe barrel filled with your assembly fluid to the adapter assembly as shown.
2. Keep the vacuum shut off during initial testing. (If you are dispensing a watery fluid, see Vacuum Control, page 12).

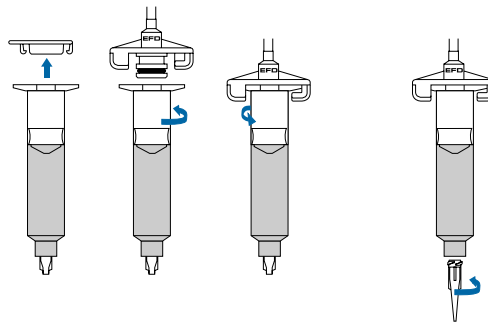

3. Replace the orange tip cap with an EFD precision dispense tip.
4. To purge the dispense tip, pull the air pressure regulator knob out until it clicks into the unlocked position. Start with pressure set to 0.
5. Press and hold the foot pedal. **Slowly**, turn the pressure knob clockwise until your fluid begins to dispense out of the tip in a controlled flow (not too fast, not too slow).
6. Push the air pressure knob in to lock setting.
7. Rest the dispense tip on the Dot Standards sheet.
8. Press the foot pedal to activate the dispense cycle. Release when you have made the correct deposit size

**Changing the length of time you press the foot pedal changes the deposit size.**

If your deposit is too small, increase the time you press the foot pedal to increase the deposit size. If your dot is too large, decrease the time to decrease your deposit size.

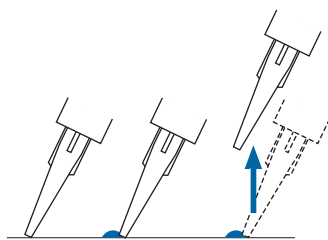

**Remember** - always bring the tip in contact with the work surface at the illustrated angle. After the tip is in position, press the foot pedal. Release pedal and remove tip by lifting straight up.

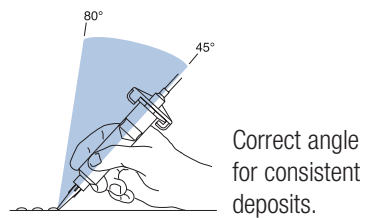

If you have any questions at this point, please call us now.

In the USA, call 800-556-3484 between 8:30 a.m. and 5:30 p.m. Eastern time.

In Europe, call +44 (0) 1582 666334.

In Asia, call +86 (21) 5854 2345.

In all other areas, call your authorized EFD distributor or +1-401-434-1680.

### 870 Parts List

- |                       |  |                         |  |
|-----------------------|--|-------------------------|--|
| 1. 2024-6MM . . . . . | .6 mm OD urethane tubing                 | 12. 2002SCR . . . . .   | Replacement screen for regulator*      |
| 2. 2001C . . . . .    | Gauge 0-100 psi (0-6.9 bar)              | 13. 78519 . . . . .     | Fitting - 1/8 NPT x 4 mm push-in elbow |
| 3. 2002-U . . . . .   | Regulator 0-100 psi (0-6.9 bar)          | 14. 1420 . . . . .      | Pneumatic foot pedal assembly*         |
| 4. 8121 . . . . .     | Fitting - 6 mm bulkhead                  | 15. 2084 . . . . .      | Air restrictor                         |
| 5. 4040 . . . . .     | Fitting - 1/8 NPT x 2 6 mm push-in elbow | 16. 2176-1400 . . . . . | Barrel vacuum control                  |
| 6. 4041 . . . . .     | Fitting - 1/8 NPT x 6 mm push-in elbow   | 17. 2170 . . . . .      | Vacuum transducer                      |
| 7. 2036 . . . . .     | Fitting - 1/8 FPT x 1/4 barb             | 18. 1419 . . . . .      | Pneumatic solenoid                     |
| 8. 2004B . . . . .    | Female quick-connect                     | 19. 8124-W . . . . .    | Tubing 4 mm OD urethane tubing         |
| 9. 4042 . . . . .     | Bulkhead stop fitting - 4 mm             | 20. 2428 . . . . .      | Barrel holder with sleeve              |
| 10. 1417 . . . . .    | Bulkhead fitting - 4 mm                  |                         |  |
| 11. 1418 . . . . .    | Differential union tee 4-6 mm            |                         |  |

\*Not Shown

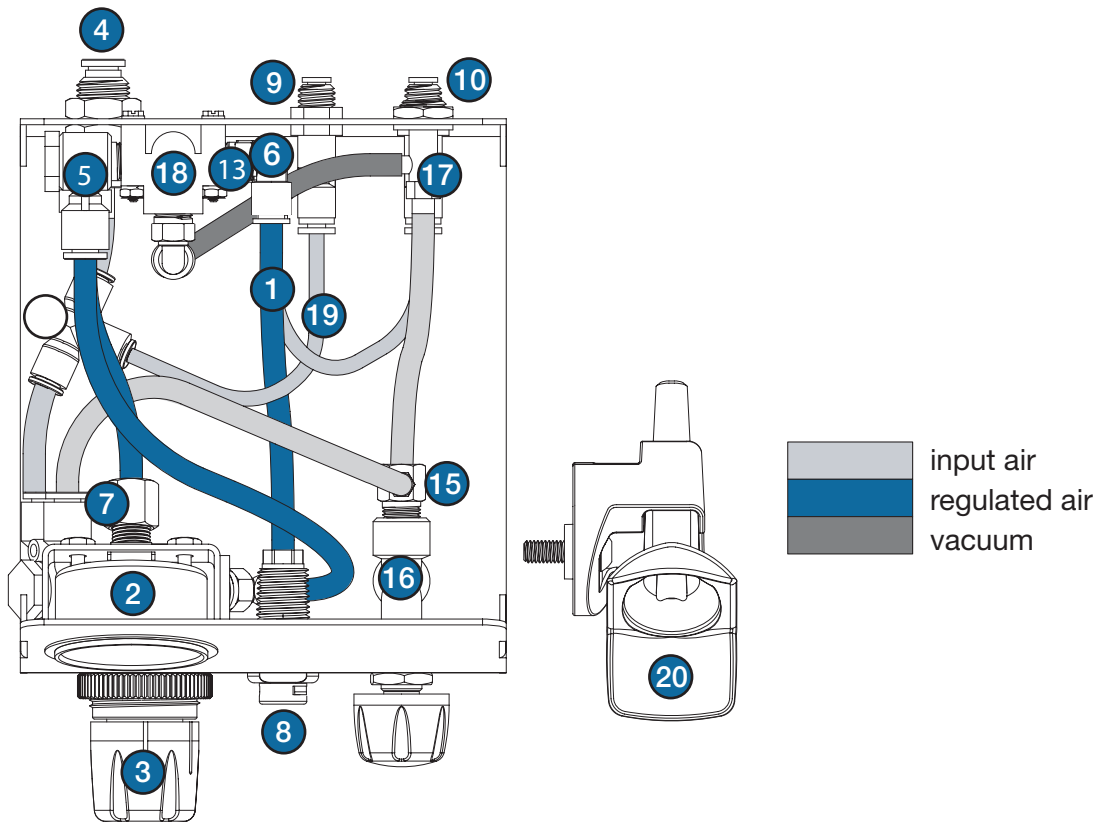



**If you encounter a problem that you cannot readily solve, call EFD.**

<b>Trouble</b>	<b>Possible cause and correction</b>
<b>Inconsistent beads</b>	<ol style="list-style-type: none"><li>1. Check dispensing tip, syringe barrel and material for possible clogging.</li><li>2. Check air pressure to be sure pressure is not varying. If needed, use the filter regulator (EFD part #2000F755).</li><li>3. Air bubbles in the material can cause inconsistency. For best results, remove all air bubbles.</li></ol>
<b>Material suck-back</b>	<ol style="list-style-type: none"><li>1. Use a SmoothFlow piston or LV Barrier to prevent material being drawn into the dispenser.</li><li>2. Another option is to order the filter trap accessory, which prevents fluid from leaking into the dispenser. Order EFD part #1000FLT-Y.</li><li>3. If suck-back occurs, attach an empty barrel, place the barrel in a cup, then press the foot pedal to expel the fluid.</li><li>4. If the problem cannot be corrected, contact an EFD Fluid Application Specialist for assistance.</li></ol> <p>Dispensers can be returned to EFD for repair.</p>

### Helpful Hints

1. There are three core variables to the Ultra 870 dispenser: foot pedal time, pressure and vacuum. Adjust just one of these at a time, in small increments, to achieve the correct deposit.
2. Another variable is tip size. Choose the right tip for the deposit type. Remember, smaller tips require more pressure and more time pressing the foot pedal. Try different tips without changing the time or pressure settings and observe the results.
3. Tapered tips reduce the amount of air pressure needed to dispense thick materials. They also help prevent drooling at the end of a dispense cycle.
4. To ensure smooth fluid flow and to make consistent deposits, keep the dispense tip at a 45° angle to the work surface.
5. Use EFD SmoothFlow pistons to make barrel loading, dispensing and handling cleaner, safer and more accurate. Caution: If you dispense watery fluids and choose not to use EFD pistons, do not increase vacuum pressure rapidly and do not tip the barrel. Vacuum may pull fluid into the adapter hose, or if the syringe barrel is tipped, fluid may flow back into the dispenser.
6. Always use new EFD syringe barrels and tips. Carefully dispose of after use. This procedure ensures maximum cleanliness, prevents contamination and provides proper safety.
7. Do not completely fill the syringe barrel. For most fluids, optimum fill is a maximum 2/3 of the barrel capacity. For cyanoacrylates or watery fluids, optimum fill is 1/2 of the barrel capacity.

### Suggestions on Settings

1. To reduce air pressure, turn the knob counterclockwise until the display reads at a lower-than-needed pressure setting. Then turn clockwise to increase pressure until you reach the correct setting.
2. Avoid high pressure settings with very small deposit settings. The ideal setup matches air pressure and tip size to create a “workable” flow rate – no splashing, but not too slow either.
3. With any fluid, always give the air pressure time to do its job. Moderate time and pressure provides the best results since dispensing pressure remains at its peak for a longer period of time.

Choose from this list of optional accessories for your Ultra 870 dispenser.

### Flexible arm syringe barrel holder

This flexible arm mounts to the cabinet and can be adjusted to multiple heights and angles. Specify EFD part #2429.

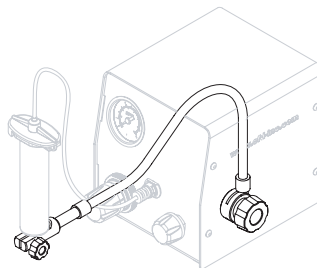

### Stiff arm barrel holder

This stiff arm mounts to the cabinet and securely holds the syringe barrel in a fixed position. Specify EFD part #2434.

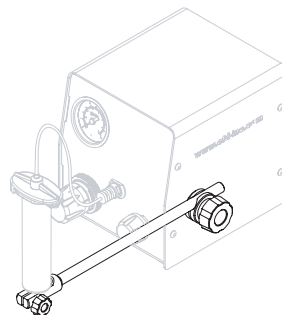

### Ergonomic hand grip

Ergonomic grip fits all sizes of syringe barrels from 3cc to 55cc. Specify EFD part #2441.



### Liquid filter trap

Helps to prevent fluid from being sucked back into the dispenser. Specify EFD part #1000FLT-Y.



### Five-micron regulator

Required for production areas where clean, dry filtered factory air is not available, or to stabilize plant air supply for more consistent deposits. Specify EFD part #2000F755.

For dispensing cyanoacrylates, order the regulator with a coalescing filter that removes liquid aerosols from the air supply (EFD part #2000F756).

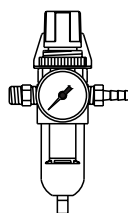

### Cleanroom filter muffler

Attaches to the Ultra 870 exhaust port and filters output air to meet Fed 209-B (0.5 micron particulates). Designed for use in cleanroom environments. Specify EFD part #2170FT.

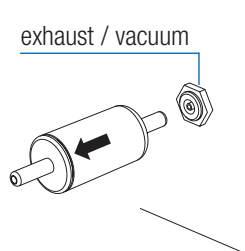

## **EFD Two Year Limited Warranty**

All components of EFD dispensers are warranted to the original end user for two years from date of purchase.

Within the period of this warranty, EFD will repair or replace free of charge any defective component on return of the part, or the complete dispenser, prepaid to the factory.

In no event shall any liability or obligation of EFD arising from this warranty exceed the purchase price of the equipment. Before using, user shall determine the suitability of the product for his intended use, and user assumes all risk and liability whatsoever in connection therewith. This warranty is valid only when clean, dry, filtered air is used.

EFD makes no warranty of merchantability or fitness for a particular purpose. In no event shall EFD be liable for incidental or consequential damages.



**For EFD sales and service in over 30 countries,  
contact EFD or go to [www.efd-inc.com/contact](http://www.efd-inc.com/contact)**

---

### **EFD, Inc.**

East Providence, RI USA  
800-556-3484; +1-401-434-1680 (outside the USA)  
info@efd-inc.com                      www.efd-inc.com

### **EFD International Inc.**

Dunstable, Bedfordshire, UK  
0800 585733 or +44 (0) 1582 666334  
Ireland 00800 8272 9444  
europe@efd-inc.com                      www.efd-inc.com

### **EFD, Inc., Asia**

China: +86 (21) 5854 2345  
china@efd-inc.com                      www.efd-inc.com/cn  
Singapore: +65 6896 9630    sin-mal@efd-inc.com