

# ALLIANCE

Alliance Products, LLC  
Murfreesboro, TN 37129  
1-800-522-3973

## OPERATIONS MANUAL

### DALPH1022 HEATED PELLET / PLATE DISPENSER

<b>GENERAL INFORMATION .....</b>	<b>3</b>
<b>RECEIVING INSPECTIONS .....</b>	<b>3</b>
<b>INSTALLATION .....</b>	<b>4</b>
<b>ELECTRICAL .....</b>	<b>5</b>
<b>START-UP .....</b>	<b>6</b>
<b>CLEANING .....</b>	<b>7</b>
<b>TROUBLESHOOTING.....</b>	<b>8</b>
<b>PARTS LIST / DIAGRAMS .....</b>	<b>9</b>
<b>PREVENTIVE MAINTENANCE .....</b>	<b>13</b>
<b>WARRANTY .....</b>	<b>14</b>
<b>SERVICE AND ASSISTANCE.....</b>	<b>14</b>
<b>RETURN POLICY .....</b>	<b>15</b>

## GENERAL INFORMATION

The Alliance Heated Pellet / Plate Dispensers is designed specifically for use with a wide variety of 9" plastic and stainless steel pellets and plates.

<b>Unit No.</b>		<b>DALPH1022</b>
<b>No. of Stacks</b>		2
<b>Capacity per Stack</b>		43 - 50
<b>Total Capacity</b>		86 – 100
<b>Overall Dimensions:</b>		
Length		36"
Width		23 3/4"
Height		42 13/16"
<b>Electrical Requirements</b>		
Voltage / Phase		208V / 1
Amperage		17.2
Cycle		60
NEMA Plug Configuration		6-20P
Shipping Weight (approx.)		285 lbs.

## RECEIVING INSPECTIONS

**NOTE:** All Alliance units are factory tested for performance prior to shipment.

Upon receipt, the crate should be inspected for visual damage, any damage should be reported immediately to the carrier.

## **Alliance Damaged Goods Policy**

There are two types of damaged merchandise:

- A. Visible Damage
- B. Concealed Damage

**A. Visible Damage** – The product being received is visibly damaged.

1. The receiver should refuse the damaged merchandise.
2. The receiver should sign the packing slip “refused merchandise due to damage” when receiving partial shipment.
3. Contact an Alliance customer service representative and alert them to the situation.

**B. Concealed Damage** – When damaged merchandise can not be externally detected.

1. Save all packing material.
2. Contact an Alliance customer service representative and alert them to the situation.
3. The receiver must call the carrier to schedule an inspection of the damaged merchandise.

## **INSTALLATION**

**NOTE: The installation instructions are similar for all models of pellet / plate heaters.**

- A. Remove all packaging materials from the unit. Remove the protective cardboard from the inside of the unit.
- B. All models are equipped with self-leveling mechanisms that are removable through the top of the unit so that adjustments can be made to the extension springs. By adding or removing springs, proper dispensing can be obtained.

## GENERAL INFORMATION

The Alliance Heated Pellet / Plate Dispensers is designed specifically for use with a wide variety of 9" plastic and stainless steel pellets and plates.

<b>Unit No.</b>		<b>DALPH1022</b>
<b>No. of Stacks</b>		2
<b>Capacity per Stack</b>		43 - 50
<b>Total Capacity</b>		86 – 100
<b>Overall Dimensions:</b>		
Length		36"
Width		23 3/4"
Height		42 13/16"
<b>Electrical Requirements</b>		
Voltage / Phase		208V / 1
Amperage		17.2
Cycle		60
NEMA Plug Configuration		6-20P
Shipping Weight (approx.)		285 lbs.

## RECEIVING INSPECTIONS

**NOTE:** All Alliance units are factory tested for performance prior to shipment.

Upon receipt, the crate should be inspected for visual damage, any damage should be reported immediately to the carrier.

## **Alliance Damaged Goods Policy**

There are two types of damaged merchandise:

- A. Visible Damage
- B. Concealed Damage

**A. Visible Damage** – The product being received is visibly damaged.

1. The receiver should refuse the damaged merchandise.
2. The receiver should sign the packing slip “refused merchandise due to damage” when receiving partial shipment.
3. Contact an Alliance customer service representative and alert them to the situation.

**B. Concealed Damage** – When damaged merchandise can not be externally detected.

1. Save all packing material.
2. Contact an Alliance customer service representative and alert them to the situation.
3. The receiver must call the carrier to schedule an inspection of the damaged merchandise.

## **INSTALLATION**

**NOTE: The installation instructions are similar for all models of pellet / plate heaters.**

- A. Remove all packaging materials from the unit. Remove the protective cardboard from the inside of the unit.
- B. All models are equipped with self-leveling mechanisms that are removable through the top of the unit so that adjustments can be made to the extension springs. By adding or removing springs, proper dispensing can be obtained.

<b>GENERAL INFORMATION .....</b>	<b>3</b>
<b>RECEIVING INSPECTIONS .....</b>	<b>3</b>
<b>INSTALLATION .....</b>	<b>4</b>
<b>ELECTRICAL .....</b>	<b>5</b>
<b>START-UP .....</b>	<b>6</b>
<b>CLEANING .....</b>	<b>7</b>
<b>TROUBLESHOOTING.....</b>	<b>8</b>
<b>PARTS LIST / DIAGRAMS .....</b>	<b>9</b>
<b>PREVENTIVE MAINTENANCE .....</b>	<b>13</b>
<b>WARRANTY .....</b>	<b>14</b>
<b>SERVICE AND ASSISTANCE.....</b>	<b>14</b>
<b>RETURN POLICY .....</b>	<b>15</b>

## TROUBLESHOOTING

### CAUTION

Thermostat adjustment should only be made only by qualified personnel.

<u>Complaint</u>	<u>Problem</u>	<u>Solution</u>
A. Unit does not heat but fan operates.	1. Open high limit thermostat.	1A. Push reset button. 1B. Check for causes before restarting equipment. 1C. Replace hi-limit thermostat.
	2. Loose wiring.	2. Check and secure wiring.
	3. Defective heating element.	3. Replace heating element.
B. Unit heats, but fan does not blow.	1. Defective motor.	1. Replace motor.
	2. Jammed or loose fan blade.	2. Replace or tighten blade.
	3. Loose wiring.	3. Determine fault and correct.
C. Unit does not operate and light does not come on.	1. No power.	1. Make sure plug is connected and switch is ON. Check for power to receptacle.
	2. Bad power switch.	2. Replace power switch.
	3. Loose wiring.	3. Check and secure wiring.
D. Pellet / plate temperature is too low, fan operating.	1. Thermostat set too low.	1. Readjust thermostat.
	2. Jammed or loose fan blade.	2. Replace or tighten blade.
	3. Cover is open.	3. Close cover.
E. Pellet / plate temperature is too high, fan operating.	1. Thermostat is set too high.	1. Readjust thermostat.
	2. Closed thermostat.	2. Replace thermostat.
	3. Closed high limit switch.	3. Replace high limit switch.
F. Cover is loose.	1. Hinge screws are missing or loose.	1. Replace or tighten screws.
G. Dispenser binds.	1. Improper springs.	1. Depending on contents use correct number of springs, Make sure identical number and size of springs are on each elevator.
	2. Debris on guide rods.	2. Clean off debris.
H. Cabinet does not roll easy.	1. Debris on wheel or axle.	1. Clean out debris.
	2. No lubrication.	2. Lubricate axles with load bearing grease. Lubricate swivel bearings with 30-weight oil.



- C. If a spring adjustment is required, proceed as follows. Lift elevating mechanism assembly up and out of the stainless steel cabinet. Set it on the floor. Disconnect but do not remove any unnecessary springs from the elevator carrier and replace mechanism back into the heater.
- D. See **ELECTRICAL** and **START-UP** sections before plugging unit into power supply.

## **ELECTRICAL**

Refer to the specifications data on page 3, the serial label, your local code or the National Electrical Code to be sure the unit is connected to the proper power source. A protected circuit of the correct voltage and amperage must be available for connection of the line cord. Place the unit near enough to the electrical outlet so the power cord is not stretched or strained. Once the unit is properly located, push down on the two caster brakes to lock them into place. **All pellet / plate heaters are provided with a NEMA plug type 6-20P.**

### **WARNING**

Every pellet / plate heater is fitted with a grounded power cord and must be connected to a properly grounded receptacle. Each receptacle must be wired to a dedicated circuit breaker rated at not more than 20 amps.

### **WARNING**

To prevent electrical shock hazard, the main power switches must be turned to “off” position and the heater disconnected from the power source whenever performing service or maintenance.

### **WARNING**

Hazardous voltage inside back of cabinet. Only qualified personnel totally familiar with electrical circuits, service manual, and service procedures should open or work inside unit.

## DALPH1022 Exploded View Drawing

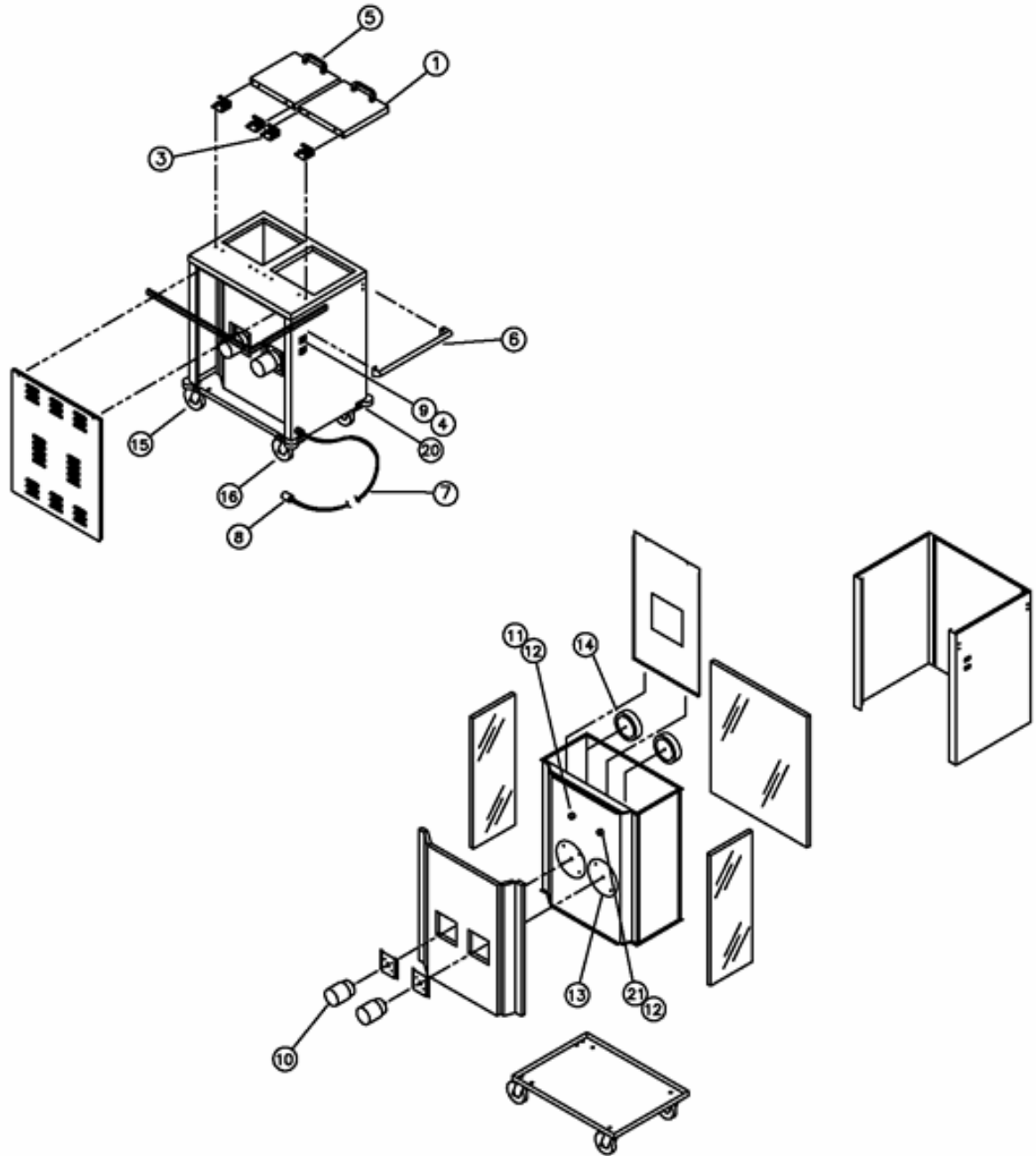

## Dispenser Assembly Exploded View Drawing

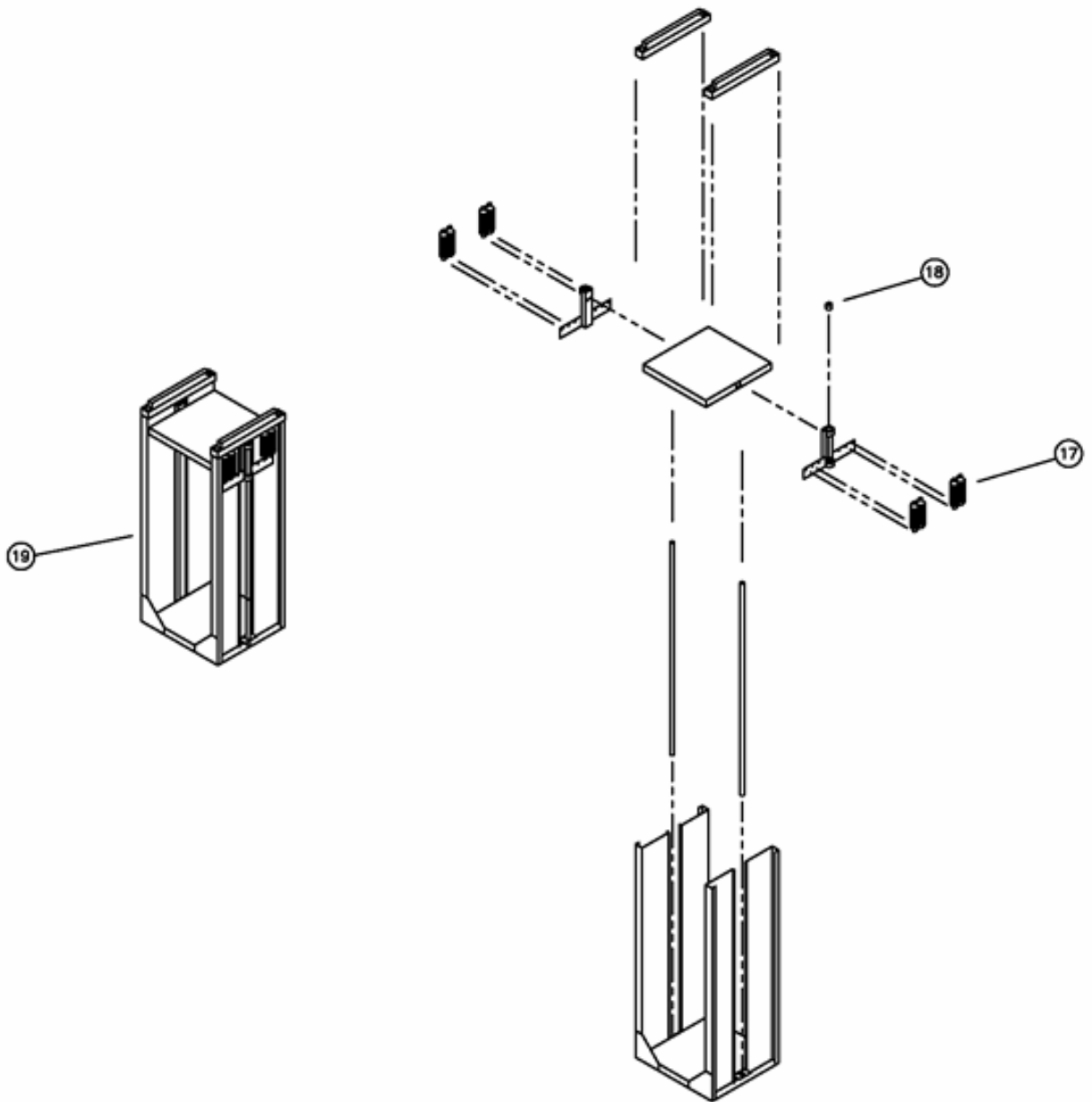

## **CAUTION**

Operators should always wear gloves or use pellet / plate lifters when dispensing.

After the unit is turned off, the pellets / plates remaining inside the unit will remain hot for some time.

## **CLEANING**

### **CAUTION**

Make sure unit is unplugged and cool before attempting to clean.

**The following procedures should be followed during the regular cleaning routine on all of the pellet heaters.**

1. Turn the unit off, disconnect the plug from the outlet, and allow the cabinet to cool. Remove plug by pulling it straight out. **Never pull on cord.**
2. Pull the elevator mechanisms up and out, place them on a work surface. You can wipe down the mechanisms with a damp cloth to clean them.
3. Clean out any debris inside the cabinet and wipe the cabinet down with a damp cloth.
4. Place the elevator mechanisms back inside the cabinet and clean the outside of the cabinet with a mild, non-abrasive soap or detergent in a warm water solution. A commercial stainless steel cleaner can also be used for this procedure.

**NOTE:** Do not use abrasives, harsh chemicals, or chlorine products for cleaning.

---

### **WARNING**

Do not steam or pressure clean or hose down the cabinet. This could damage the equipment and possibly cause an electrical shock to the operator.

### **WARNING**

Repairs should be done by qualified service personnel only.

## **WARNING**

Unit must not be run continually and must be turned off between meals. Otherwise, unit may shut off automatically requiring service reset. Warranty may be voided if used improperly.

## **START-UP**

### **A. Overview**

These units are designed to heat plastic or stainless steel pellets or plates. The fan motor, heating element, and power indicator light will come on once the unit is turned on. Each well has a power indicator light to let the operator know the power is on.

The fan motor will begin to circulate the heated air in and around the plates / pellets in a convection process that promotes a quick and even heat absorption by the contents.

Once the air inside the cabinet has reached the desired and preset temperature, the thermostats will continue to maintain this temperature by regulating the power to the heating elements. The fan motor will run as long as each well is energized.

### **B. Loading**

Load carrier shelf by carefully stacking the pellets / plates in each cavity. Always keep the load leveled on the shelf or it could bind.

### **C. Power**

Set the power switches to the “ON” position. The power switches will light up when the unit is on.

Keep the covers closed completely to insure proper and efficient heating.

Depending on the stack size, and the pellet / plate material, the heating time will vary. The heater should always be turned on 60 to 90 minutes before dispensing.

### **D. Dispensing**

## **WARRANTY**

### **One year on parts – 90 days on labor.**

Alliance provides to the original purchaser, only, a warranty for the DALPH1022. This warranty covers products and parts which prove to be defective in materials or workmanship within one (1) year of the date of shipment from the ALLIANCE factory. Repair or replacement will be at the option of ALLIANCE and will be f.o.b. the ALLIANCE factory. Warranty includes ninety (90) days for labor from date of shipment. Prior written authorization from the ALLIANCE customer service department is required before any component parts or equipment can be accepted by ALLIANCE for repair, replacement, or credit under this warranty. This warranty shall not apply if it is determined by ALLIANCE that equipment or parts have been used other than in accordance with the operating instructions, subject to abuse or misuse, damage through no fault of ALLIANCE or its employees, or altered by someone other than ALLIANCE or its authorized agents. This warranty is exclusive and in lieu of all other warranties express or implied, or statutory, including the implied warranties of merchantability and fitness. In no event shall ALLIANCE be liable for any delay in the performance of this warranty due to causes beyond its control.

## **SERVICE AND ASSISTANCE**

**In Warranty Service** – Call the Alliance Customer Service Department at **1-800-522-3973**. Parts are stocked at the factory and will be provided to a local authorized service agency.

**Out of Warranty Service** – Same as above except parts will be billed to the customer or the service agency as dictated by the customer. Labor will be billed by the agency.

**Technical Assistance** – Write down the nature of the problem and any symptoms along with any other information that might prove helpful in solving your problem. Then call the Alliance Customer Service Department at **1-800-522-3973**.

## **Return Policy**

No product may be returned to Alliance without Alliance's prior written approval. Transportation charges are to be prepaid by the Buyer.

Returned goods are subject to Alliance's inspection and acceptance. Alliance may, at its discretion, replace any or all returned items within a reasonable time after Alliance determines that the returned goods are not in accordance herewith: and in such event Alliance shall not be liable for any damage arising from the defective delivery or delay caused thereby. When expressly authorized by Alliance in writing, unused products may be returned to Alliance subject to service handling, restocking and rebuilding charges to "as new" condition.