



---

 **Novitool® Aero™ Splice Press  
Safety and Operating Manual**

---



 **WARNING**

IMPROPER OR UNSAFE use of this splice press can result in damage to the press and/or physical harm. This manual contains important information about product function and safety. Please read and understand this manual BEFORE operating the press. Please keep this manual available for other users and owners before they use the Aero press. A copy of the Aero Press Owner's Manual can be accessed on [www.flexco.com](http://www.flexco.com).



# Table of Contents

Main Components.....pg. 4

Tool Specifications.....pg.5

Introduction to the Aero™ Splice Press ..... pg. 6-7

Flight Case.....pg. 8

General Safety Rules.....pg. 8

Safe Operation of Aero™ Press ..... pg. 9-15

Technical Assistance .....pg.16

Electrical Diagram of the Power Supply Cables.....pg. 16-17

Electrical Schematics ..... pg. 18-21

Maintenance.....pg. 22

Logbook.....pg. 23

EC Declaration of Conformity .....pg. 24

## Main Components

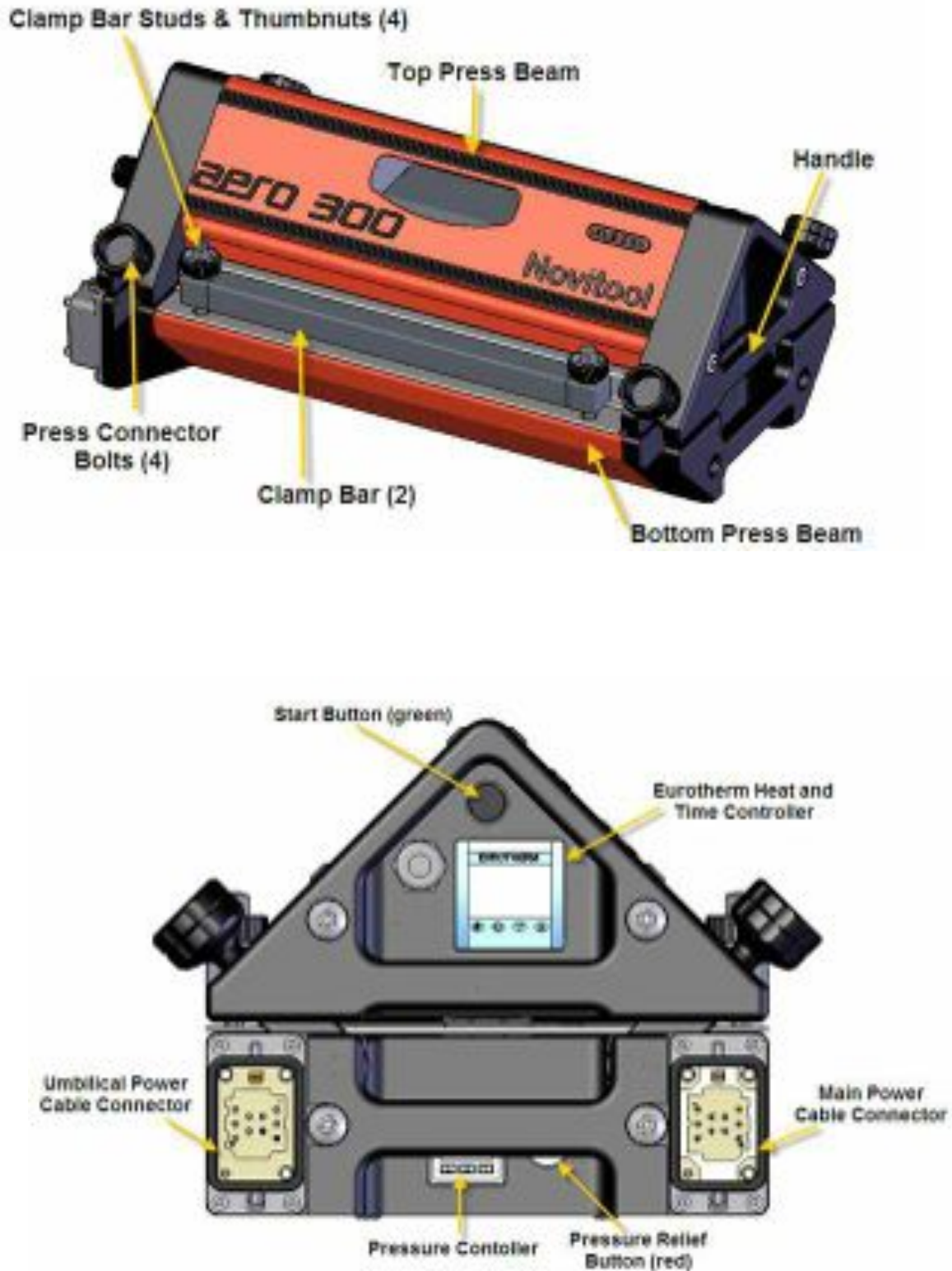

## Tool Specification

| <b>Aero™ Tool Specifications</b>     |  |   |   |   |   |
|--------------------------------------|--|---|---|---|---|
| <b>Specifications</b>                | <b>Aero 300</b>                        | <b>Aero 600</b>                         | <b>Aero 900</b>                         | <b>Aero 1200</b>                        | <b>Aero 1500</b>                          |
| Effective splice length              | 305 mm / 12 "                          | 610 mm / 24 "                           | 914 mm / 36 "                           | 1219 mm / 48 "                          | 1524 mm / 60 "                            |
| Effective splice width               | 120 mm / 4.7 "                         | 120 mm / 4.7 "                          | 120 mm / 4.7 "                          | 120 mm / 4.7 "                          | 120 mm / 4.7 "                            |
| Weight lower part                    | 10 kg / 22 lbs                         | 15 kg / 33 lbs                          | 20 kg / 44 lbs                          | 25 kg / 55 lbs                          | 30 kg / 66 lbs                            |
| Weight upper part                    | 11 kg / 24 lbs                         | 15 kg / 33 lbs                          | 18 kg / 40 lbs                          | 22 kg / 48 lbs                          | 26 kg / 57 lbs                            |
| Total weight                         | 21 kg / 46 lbs                         | 30 kg / 66 lbs                          | 38 kg / 84 lbs                          | 47 kg / 104 lbs                         | 56 kg / 123 lbs                           |
| Length                               | 505 mm / 19.9 "                        | 805 mm / 31.7 "                         | 1105 mm / 43.5 "                        | 1405 mm / 55.3 "                        | 1705 mm / 67.1 "                          |
| Overall Height                       | 220 mm / 8.5 "                         | 220 mm / 8.5 "                          | 220 mm / 8.5 "                          | 220 mm / 8.5 "                          | 220 mm / 8.5 "                            |
| Max. pressure                        | 2 Bar / 28 PSI                         | 2 Bar / 28 PSI                          | 2 Bar / 28 PSI                          | 2 Bar / 28 PSI                          | 2 Bar / 28 PSI                            |
| Max. temperature                     | 200 °C / 390 °F                        | 200 °C / 390 °F                         | 200 °C / 390 °F                         | 200 °C / 390 °F                         | 200 °C / 390 °F                           |
| Dimensions for transport (L x W x H) | 770 x 370 x 310 mm<br>(30 x 15 x 12 ") | 1070 x 370 x 310 mm<br>(42 x 15 x 12 ") | 1370 x 370 x 310 mm<br>(54 x 15 x 12 ") | 1726 x 370 x 310 mm<br>(68 x 15 x 12 ") | 1926 x 370 x 310 mm<br>(76 x 146 x 122 ") |
| Weight for transport                 | 26 kg / 57 lbs                         | 35 kg / 77 lbs                          | 43 kg / 95 lbs                          | 53 kg / 117 lbs                         | 61 kg / 134 lbs                           |
| <b>Power requirements</b>            |  |   |   |   |   |
| 1 phase 230 Vac                      | 8.8 A                                  | 14 A                                    | 16 A                                    | U.S. only 30 A                          | U.S. only 30 A                            |
| 3 phase 230 Vac                      | 4.4 A                                  | 7 A                                     | 8 A                                     | 12 A                                    | 15 A                                      |
| 3 phase 400 Vac+0                    | 4.4 A                                  | 7 A                                     | 8 A                                     | 12 A                                    | 15 A                                      |
| 3 phase 460 Vac                      | 4.4 A                                  | 7 A                                     | 8 A                                     | 12 A                                    | 15 A                                      |

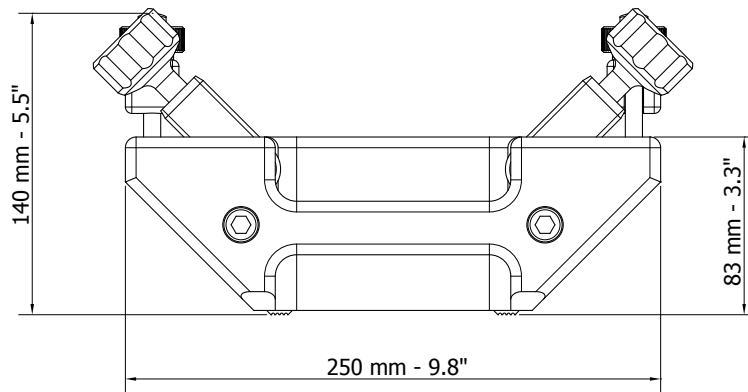

## Introduction to the Aero Splice Press

The Aero™ splice press is an all-in-one solution for splicing thermoplastic conveyor belts (e.g. PVC, polyurethane).

No external control box, air pump, or water cooling tank are required.

The Aero presses are provided with electric heating and built in air cooling. The splice process runs fully automated.

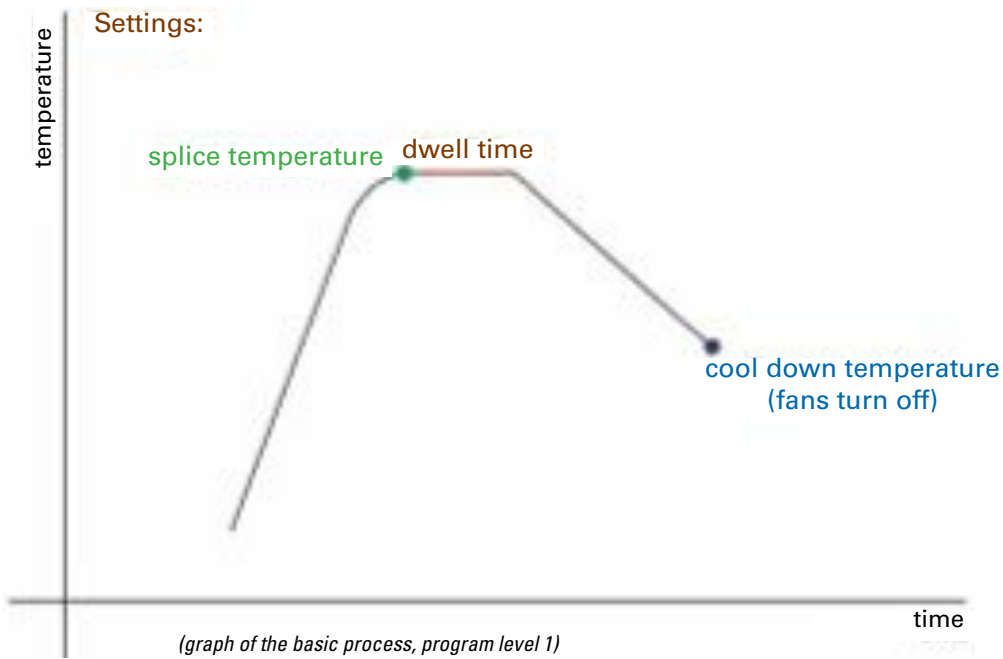

- Splice pressure is applied by an internal compressor, max. 2 bar (28 psi)
- Heats up to a splice temperature of max. 200°C (392°F)
- Keeps it at the splice temperature (adjustable dwell time)
- Cools down to the cooling temperature (safe temperature to take the belt out)
- For thicker belts a preheat temperature and preheat dwell time can be applied
- The bottom heating can be set lower or higher than the top heating

## Introduction to the Aero™ Splice Press

\* If the belt is relatively thick a problem might occur where the outside of the belt is at the splicing temperature too long, waiting for the inside to reach the required temperature. Melted material might flow away or discolor and fabrics might shrink. To avoid this problem, the preheat option can be used. This option heats the belt up (outside and inside) to a temperature just below the melting temperature. After the preheat stage, the inside splice temperature can be reached much quicker, minimizing the risk for unwanted flow of material, discoloring or fabric shrinkage.

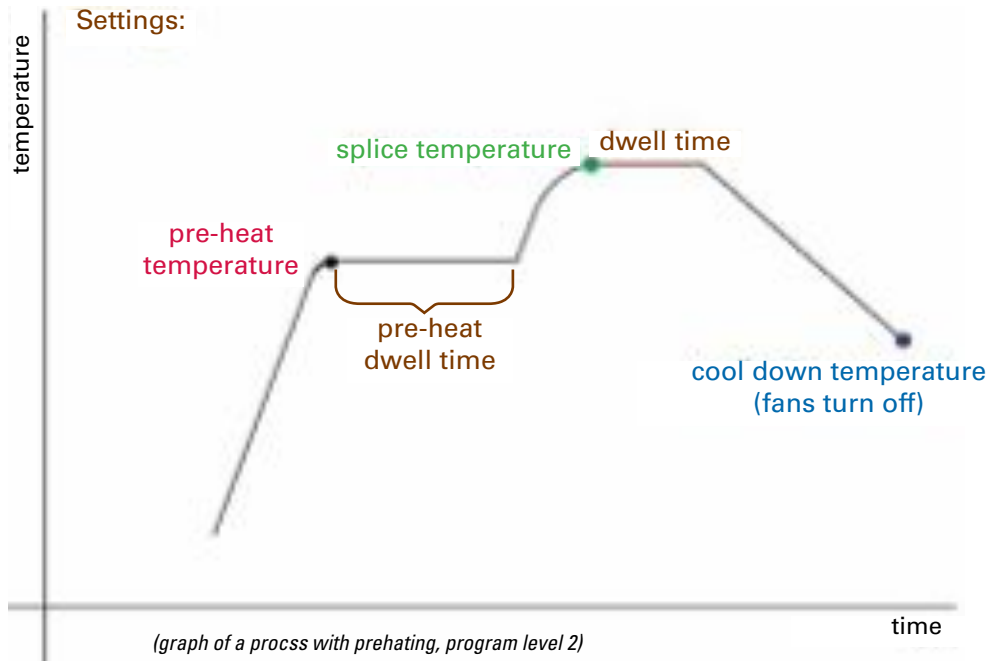

\*\* The reading of the display relates to the top temperature of the press. If more or less heat is required at the bottom of the belt, the “bottom heat factor” can be used. Please note that this factor relates to a plus or minus amount of heat (%), not to a specific temperature.

## Flight Case

1. Aero™ presses are supplied with a flight case for both storage purposes and also for easy transport to on-site jobs.
2. Place press in the flight case so the end with the power receptacles is facing the storage compartment. This will protect the receptacles from damage when transporting.
3. Flight cases for the Aero 300-900 have two wheels. Aero 1200-1500 are packaged in flight cases with four wheels and an extension handle.
4. Flight cases can be stacked on top of each other, but need to be secured during transportation.
5. Aero™ 1200-1500 flight cases feature an extended handle for ease and convenience in transport. Click in the grip of the flight case to release the handle.

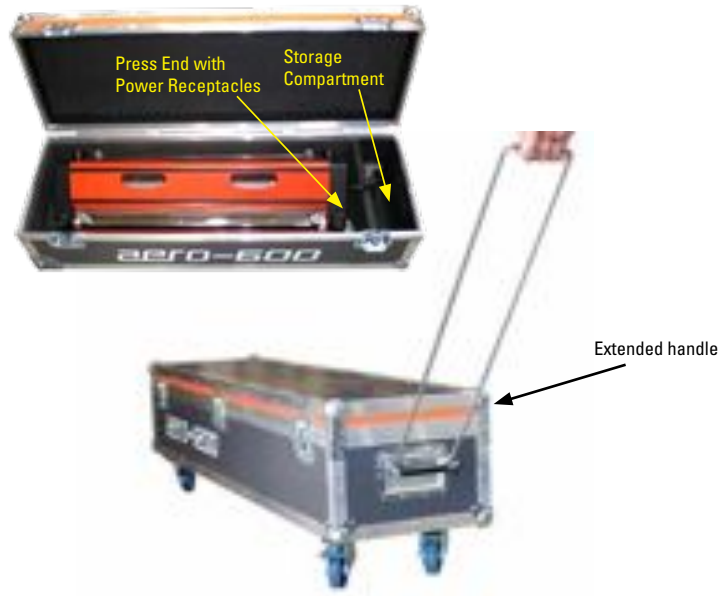

## General Safety Rules

—Save These Instructions—

### Signal words:

“DANGER” indicates an imminently hazardous situation which, if not avoided, will result in death or serious injury. The signal word is limited to the most extreme situations.

“WARNING” indicates a potentially hazardous situation which, if not avoided, could result in death or serious injury.

“CAUTION” indicates a potentially hazardous situation which, if not avoided, may result in minor or moderate injury. It may also be used to alert against unsafe practices.

### Safety Symbol



This international safety symbol is used to identify and call attention to specific safety matters.

### Safety Information

To Avoid Severe Personal Injury or Property Damage, read carefully and understand the following Safety Precautions.

### OVERALL SAFETY RULES

## ⚠ DANGER

To Avoid Severe Personal Injury or Property Damage, read carefully and understand the following Safety Precautions.

## ⚠ DANGER

Terminate electrical hazards by removing power cord from wall receptacle or machine base inlet.

## ⚠ WARNING

Terminate pressure related hazards by pressing the red pressure relief button.

## ⚠ CAUTION

Press platens develop over 5 tons of clamping force. When operating the press keep the four press connector bolts in place by hand tightening.

## ⚠ CAUTION

Avoid temperature related hazards by handling press components and belt once safely cooled.



## Safe Operation of Aero™ Press

1. Locate a position in facility where appropriate voltage and power receptacles are available to operate the Aero press.

### **WARNING**

Operating the press on incorrect voltage can cause serious damage and potential hazards. The following Aero power cords are available:

- a. 230 volt; single phase
- b. 230 volt; three phase
- c. 400 volt; three phase + neutral
- d. 460 volt; three phase

2. Visually inspect power cord:

### **DANGER**

- a. Inspect cord for damage. Do not use power cord in a damaged state. Either replace cord or have an electrician remove damaged section and reattach plug. Electrician must refer to electrical diagram on pages 16 and 17 for proper attachment.
- b. Confirm compatibility between plug end and power receptacle. If incorrect, find alternate power source or have electrician apply correct plug, referring to electrical diagram on pages 16 and 17.

### **DANGER**

- c. DO NOT plug power cord into wall receptacle at this time. Later in the operation, when ready to connect power follow these safe and proper operating procedures:
  - i. First, plug power cord into machine base power inlet.



- ii. Second, insert plug end into wall receptacle.



### **DANGER**

- iii. NEVER leave power cord plugged into wall while detached from unit as this could lead to a serious electrical danger if it comes in contact with fluids, such as water.

### **DANGER**

- d. All press power inlets and cable connectors have been supplied with keyed (patterned) guide pins and bushings. This keying will prevent incorrect connection. Do NOT alter or remove guide pins or bushings.



3. Remove press from flight case.

### **HEAVY OBJECT**

Note: Use proper lifting techniques to avoid personal injury; ask for assistance for removal from flight case if press is heavier than you are comfortable handling by yourself.

4. Visually inspect press for damage.

### **WARNING**

Broken or missing components can cause an unsafe working environment and will likely cause additional damage to press and possible bodily injury.

## Safe Operation of Aero™ Press

### DANGER

- Ensure all four press connector bolts are in good condition. Do NOT attempt to operate the press if a bolt is broken or missing.
- Inspect platens for potential damage.
- Ensure platens are free of dirt/debris. If dirty, follow these cleaning instructions:
  - Use ammonia based cleaners with clean towel to gently remove dirt/debris.

### WARNING

- Do NOT clean platens with a flammable solution.

### CAUTION

- Do NOT use water to hose down the Aero press. If press needs to be cleaned, use ammonia based solvent applied to a cloth and wipe down press. Dry press with clean dry cloth.
- Inspect all cables to ensure they are in good condition. If they are damaged, do NOT use press until they are replaced.

## 5. Visually inspect silicone pads.

Visually inspect silicone pads. Pads should be free of dirt/debris in order to obtain a quality finished splice. Pads can also be cleaned using ammonia based cleaning solution that is NON-FLAMMABLE and will not cause an adverse reaction with the splice.

## 6. Remove top beam:

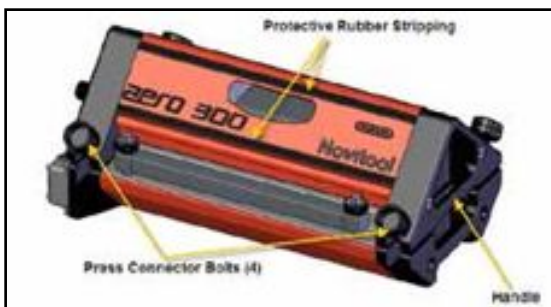

- Loosen all four press connector bolts.
- Using top beam handles located on end caps, remove top beam from press.

### HEAVY OBJECT

Depending upon width and weight of the press you have, you may require assistance from another person.

- Place beam on side, do not place the beam with the platen facing down. It is important to keep platens in good working condition. Resting the beam on the side will protect the platens from scratching or from getting dirty. Beams have rubber stripping along the length of the press to protect from scratching (see photo).

## 7. Insert prepared belt ends into the press:

- Lay clean silicone pad over clean bottom platen. Use care to lay silicone pad flat; wrinkles in silicone pad will impact the finished appearance of the splice. Silicone pads are used to prevent belt material from sticking to the platens of the press.
- Lay prepared belt ends on the bottom platen.

Note: The heated zone is in the center 130 mm width of the platen; outside of this area the platens are in the integrated cool zones. Be sure splice area is centered properly. There is some 'heat loss' on the outside areas of the heated zone, which is dependent upon the belt type. Typically the 'melt zone' is approximately 120 mm. Prepared finger splice and/or ply separation must be within the 'melt zone', as material outside of the melt zone will not become molten.

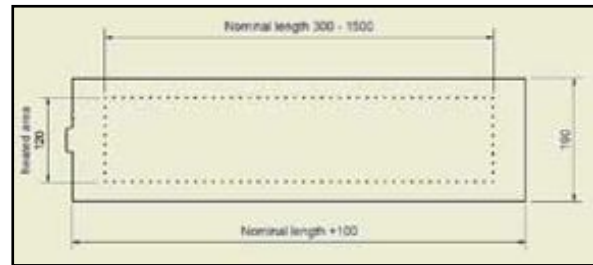

- Ensure prepared belt ends are tight together. If installing a finger splice, make sure that the finger tips are fully meshed without gaps between top and bottom of the fingers. Heat tack in place if needed.
- If film/foil is needed for the splice; apply to prepared belt end.
- It is important to use 'bumpers'. Bumpers prevent the melted material from flowing outside of the belt width and also provide stability in the press.

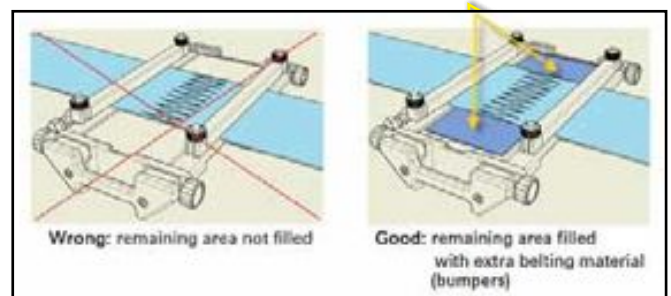

### CAUTION

The bumpers must be to a width that will fill the balance of the press to ensure even pressure and prevent damage to the press.

- Install clamp bars, ensuring that fingers remain tightly meshed.
- Lay clean silicone pad over the prepared splice, using care to avoid wrinkles in the silicone pad.

## Safe Operation of Aero™ Press

### 8. Install top beam:

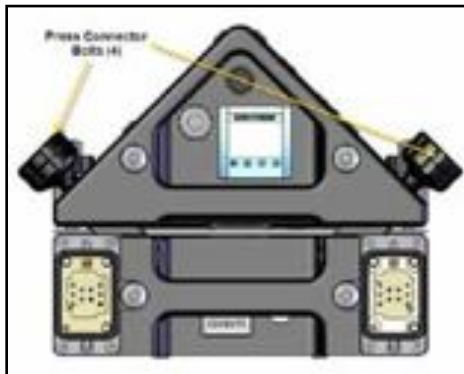

- a. Carefully position top beam onto prepared belt ends; avoid disrupting prepared belt ends and possibly separating the fingers.

### **!** HEAVY OBJECT

If weight and length of top beam is difficult to handle by yourself, enlist assistance of another person.

- i. Aero 900, 1200, and 1500 models include a fixture to aid in sliding top beam in place if access to position beam is difficult. Install fixture in slots of end caps. Slide top beam the length of the tool. Lift end to remove fixitive.



### **!** DANGER

- b. With the top beam properly centered, rotate all four press connector bolts up and hand tighten, ensuring bolts are seated properly in spherical recess on top beam.

### **!** CAUTION



- i. Do not allow users to get fingers caught in potential pinch points.

### **!** DANGER

- ii. Press is capable of producing a force up to 10,250 pounds (45,600 N). Do NOT operate the press with a missing or broken bolt as this can cause serious physical harm and/or damage to press. If a bolt is missing or broken, replace with authorized factory parts only.

### **!** WARNING

- iii. To ensure proper thread engagement, the prepared belt ends (including various pads) cannot exceed 15 mm (0.59"). This does not necessarily relate to the press' heating capability. Exceeding this thickness will not allow sufficient thread engagement of the Connecting Bolts to ensure safe clamping of the press, and can result in damage to the press and personal danger.

### 9. Remove belt clamps after top beam is secured:

Failure to remove clamps may result in incomplete melt zone at ends of splices that are full press width.

### 10. Connect umbilical power cable from top beam to bottom beam:



- a. Insert umbilical power cable connector into machine base umbilical cable connector.
- b. Engage latch to lock plug in place. Forgetting to latch plug can result in intermittent power supply to press base controls.

## Safe Operation of Aero™ Press

### 11. Connect power cord to press:

#### **WARNING**

It is extremely important that the power cord is attached to the press first and then to the wall receptacle. Reversing these procedures can put personnel at risk of electrocution and may cause a damaging electrical arc.

- a. Insert power cable connector to the machine base power outlet.



- b. Engage latch to lock plug in place. Forgetting to lock plug can result in intermittent power supply to the press.



#### **DANGER**

- c. Double check to ensure the voltage and receptacle is appropriate for the power cable you are using. Incorrect, excessive power voltage can cause serious damage to press and also present physical danger (i.e. 460 volt outlet feeding into a 230 volt cable could cause a short circuit and/or fire).

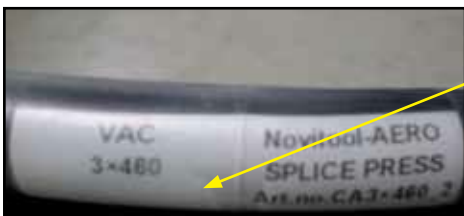

Note cable voltage requirement

- d. Next, insert power cable plug into the appropriate wall receptacle.



#### **DANGER**

- e. User wiring of electrical plug to bare power cable end or hard wiring cable to junction box MUST be in accordance with the 'Electrical Diagram of Power Supply Cable' on pages 16 and 17. Ensure proper cable diagram is used for cable being wired. Ensure the correct plug is used. Only qualified personnel should perform this activity.

The Aero press has 2 controllers:

1. The temperature controller located on the top beam has two levels of programming:
  - a. Level 1 Programming: Splice temperature (max 200°C/392°F), splice dwell time, cool down temperature.
  - b. Level 2 Programming: Preheat temperature, preheat dwell time, bottom heat factor (lower or higher than top platen heating), cool down temperature, and units (Centigrade or Fahrenheit).
2. The pressure controller is located on the bottom beam and controls the pressure up to 2 bars/28 psi.

### 12. Setting Splice Parameters:

Connect the Aero™ press to the power supply. The following parameters can be set:

- a. Controller on top part of the Aero
  - i. Input level 1
    - Splice temperature (max. 200°C/392°F)
    - Splice temperature dwell time
    - Cool down temperature
  - ii. Input level 2
    - Preheat temperature
    - Preheat dwell time
    - Splice temperature
    - Splice temperature dwell time
    - Cool down temperature
    - Bottom heat factor (lower or higher than top heating)
- b. Controller on bottom part of the Aero
  - i. Splice pressure (0-max. 2 bar/28 psi)







## Safe Operation of Aero™ Press



The Eurotherm controller defaults at start up to Level 1 programming. All settings are presented as an abbreviation, e.g. "SPL.T". If you wait a moment a readable text is shown, e.g. "Splice Temperature".

### Level 1 Input:

- a. Setting Basic Temperature and Dwell Time Inputs.
  - i. Setting of the splice temperature
    - Push button . The first value shown is splice temperature (SPLT).
    - Change the actual setting by pushing the UP▲ or DOWN▼ button.
    - Wait for one second and the displayed value blinks to confirm that it is set.
    - Maximum temperature is limited to 200°C (392°F).
  - ii. Setting splice temperature dwell time
    - Push button  until display shows "SPLDT".
    - Push UP▲ or DOWN▼ button to adjust dwell time;
    - Wait for one second and displayed value blinks to confirm that it is set.
  - iii. Setting cool down temperature (when cooling fans will turn off).
    - Push button  until display shows "CLD.T".
    - Push UP▲ or DOWN▼ button to adjust cool down temperature.
    - Wait for one second and displayed value blinks to confirm that it is set.
    - Return to start up status by pushing button  again.

Splice Pressure (bottom controller)

- b. Setting splice pressure
  - Briefly push the middle button **S** (display shows set value).  
 **DON'T HOLD S BUTTON** or otherwise the parameter menu will open.
  - Push UP▲ or DOWN▼ button to adjust splice pressure.
  - When desired value is shown set by briefly pushing middle button **S** again.
  - Maximum pressure is limited to 2 bar (28 psi).

### Additional temperature and dwell time settings: Changing to Level 2 programming:

Setting of the splice temperature

- Push button and hold button  until display shows "LEV1".
- Push the UP▲ button once and display shows "LEV2".
- Program level 2 settings are available now.

Setting preheat temperature (default value 100°C)

- Push button . The first value which is shown on the display is the preheat temperature (PREHT).
- Change actual setting by pushing UP▲ or DOWN▼ button.
- Wait for one second and displayed value blinks to confirm that it is set.
- Maximum preheat temperature is limited in controller to 175°C (347°F).

Setting preheat dwell time (default value 0 sec)



- Push button  until display shows "PREHD".
  - Push UP▲ or DOWN▼ button to adjust dwell time.
  - Wait for one second and displayed value blinks to confirm that it is set.
- Note: Splice temperature, splice dwell time, and cool down temperature will remain in effect from Level 1 programming..

Setting splice temperature, splice dwell time, and cool down temperature.

Setting of the bottom platen at a lower temperature (default value 0°)

- Push button  until display shows "BOTHF".
- Push UP▲ or DOWN▼ button to adjust percentage of power that is desired for bottom platen (e.g.-10=sending 90% of the power supplied to the bottom platen.) You can adjust +5% to -99% power. Note: Actual bottom heat temperature cannot be input.
- Wait for one second and displayed value blinks to confirm that it is set.

Changing from degrees Centigrade to Fahrenheit and reverse

- Push button  until display shows "UNITS"
- Push UP▲ or DOWN▼ button to change from °C to °F or reverse.
- Wait for one second and displayed value blinks to confirm that it is set.
- Return to start up status by pushing button  again.

**ATTENTION:** If the Aero is disconnected from the power supply, or the top part is disconnected from the bottom part, all extra settings of level 2 return to their default value. Only the basic settings (as level 1) and the setting for units (°C/°F) will be kept.

## Safe Operation of Aero™ Press

### 13. Start Splicing Operation:

#### **DANGER**

Before initiating splicing cycle, confirm all four press connector bolts are engaged with top of press and are hand-tight. Depress green 'Start' button. Air compressor will start and you will be able to view status of splicing cycle by watching digital display on control panel. Air pressure will continue to build after the compressor stops.

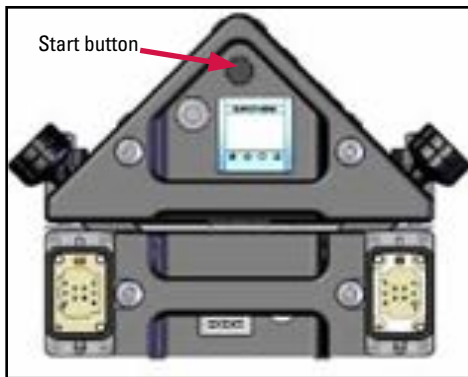

Note: It is common for the air pressure to continue to rise beyond input value. This is due to the effect of the heat generated by press causing additional expansion in air bladder.

Although press remains fairly cool during entire splice cycle, it is wise to avoid touching press during heating and cooling down process.

Note: The Aero has been optimized for process speed, portability and ease of use. A resulting affect of the designed portability of the press is that the structure will deflect as internal air pressure is increasing during the splicing process. The length of the press will determine how much deflection will occur at any specific pressure. Beam extrusions were designed with strength to return to their normal state when pressure is relieved; deflection will not be permanent.

#### **WARNING**

Keep fingers clear of deflected beams.

#### **CAUTION**

The Aero press does not have an 'Emergency Stop' button. If there is a need to stop the press mid-cycle, then disconnect the press from power source and allow press to cool.

NOTE: Temperature cycle may be aborted by simultaneously pressing and holding the ▲ and ▼ buttons.

### 14. Splicing Cycle:

During the splicing cycle you will be able to monitor progress by viewing the display output. Fans will start up at the end of the cook cycle to assist with fast cooling of the splice. If the fans do not start, contact Flexco for assistance.

### 15. Release Pressure:

After splicing cycle is complete, depress the red pressure relief valve button until the pressure is fully relieved.

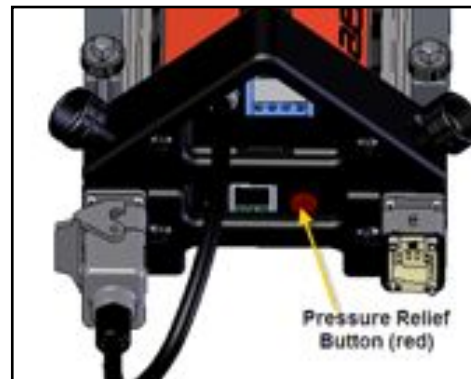

#### **WARNING**

Keep fingers clear of any potential pinch points, especially where beams have temporarily deflected during the splicing cycle, as they will return to their normal state when pressure is relieved.

### 16. Disconnect main power cable:

#### **DANGER**

- It is critical to remove the power cord from the wall receptacle first.



## Safe Operation of Aero™ Press

- b. Next, unlatch the cable connector from the machine base power inlet and gently disconnect.

Following this sequence is critical for operator and bystander safety. Removing plug from the wall receptacle first eliminates any current from flowing through the cable. If this procedure is not performed first and the cable connector is removed initially, the power cable remains energized and could cause serious and fatal shock if exposed to water or other fluids.

### 17. Disconnect umbilical power cord from top beam:

- a. Unlatch cable connector.
- b. Gently disconnect.

### 18. Remove Top Beam:

- a. Loosen all four press connector bolts.
- b. Lift top beam off and place beam on side; do not place beam with platens facing downward in contact with a surface.

### CAUTION

Platen surfaces may be hot.

- c. Remove top silicone pad and inspect splice. Elements of a properly installed endless splice include:
  - i. Limited but consistent flow of PVC/Urethane material through the splice.
  - ii. Proper bonding, especially at the tips of the fingers. 'Pin Holes' should not be present at finger tips.
  - iii. Bending of the splice joint should not create any separation at the finger edges.
  - iv. No scorching of the belt cover or bottom ply should be evident.

### 19. Packing Press in Flight Case:

- a. Reassemble top beam onto press, tighten all four press connector bolts, and install clamp bars on press.
- b. Carefully place press in flight case. Note: Press must be placed in case with power receptacles facing the storage area. This will protect receptacles from getting damaged during transportation.

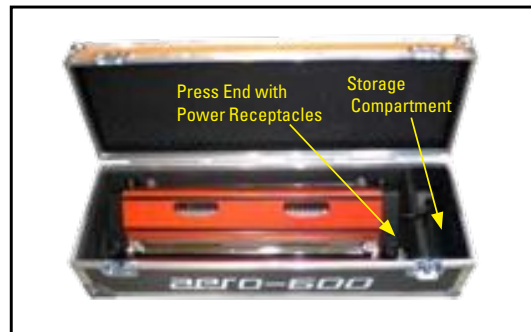

- c. Place power cords in storage compartment.
- d. Close case and engage the locking latches.

## Electrical Diagram of the Power Supply Cables

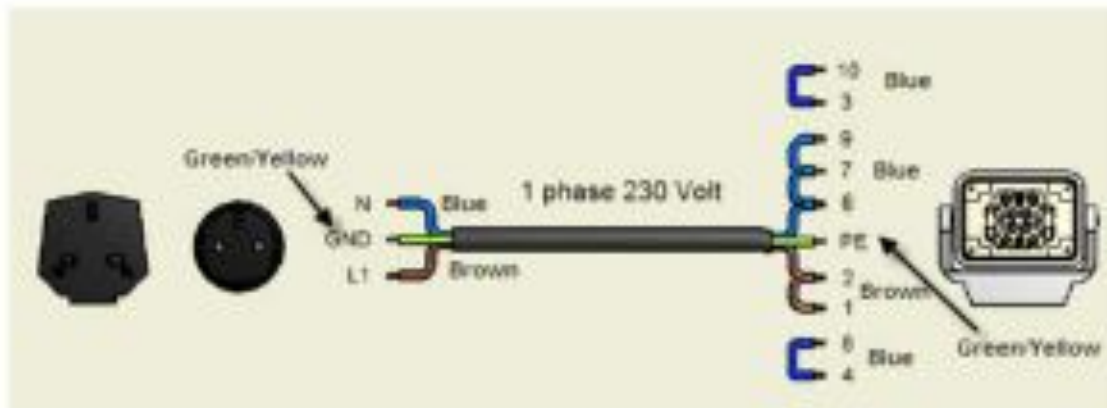

European and UK cable, single phase



USA cable, single phase

## Technical Assistance

Contact Flexco's Customer Service if technical assistance or repair parts are needed.:  
[www.flexco.com](http://www.flexco.com)



Electrical Diagram of the Power Supply Cables

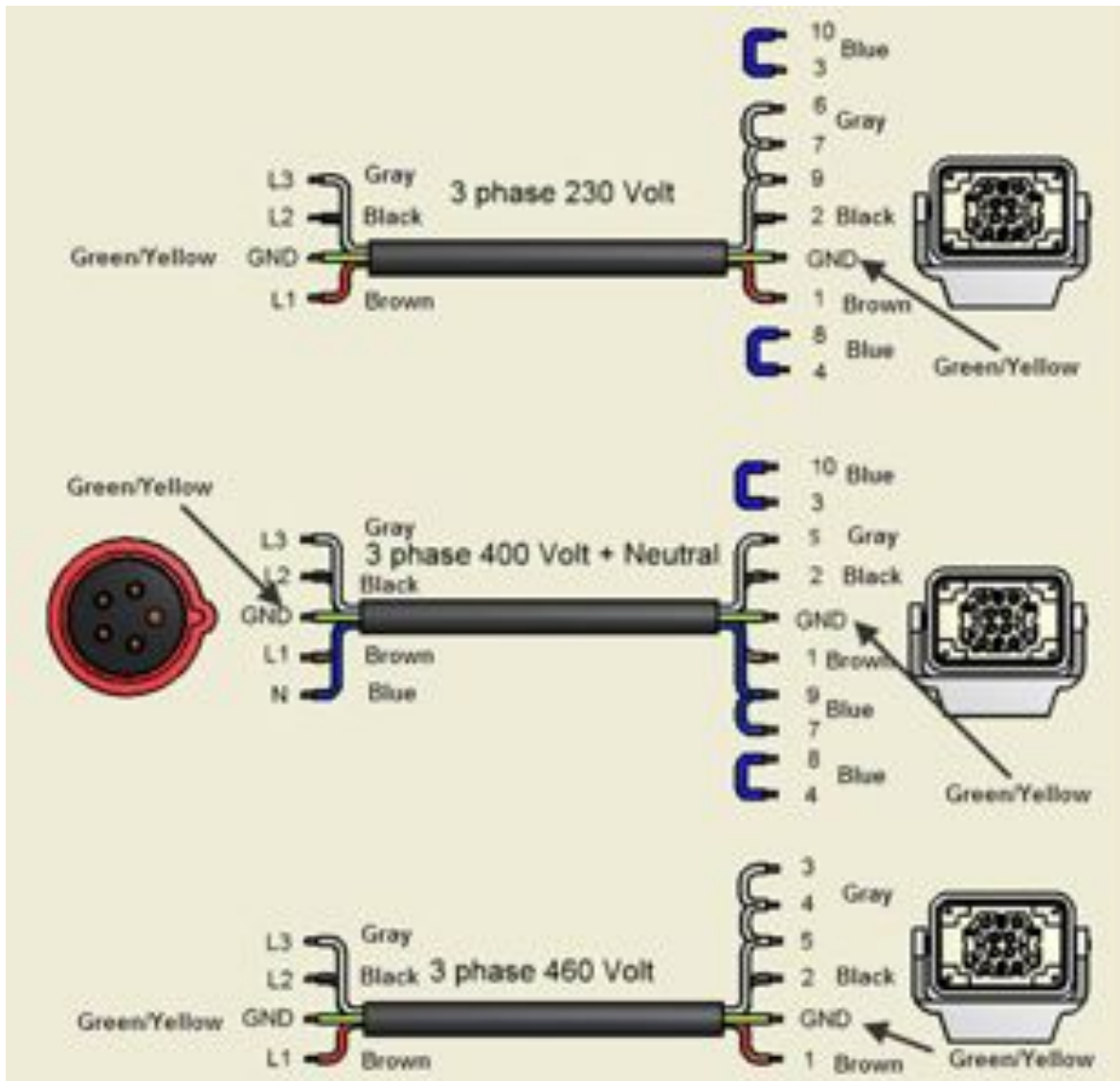

Three phase cables

**Electrical Schematics**

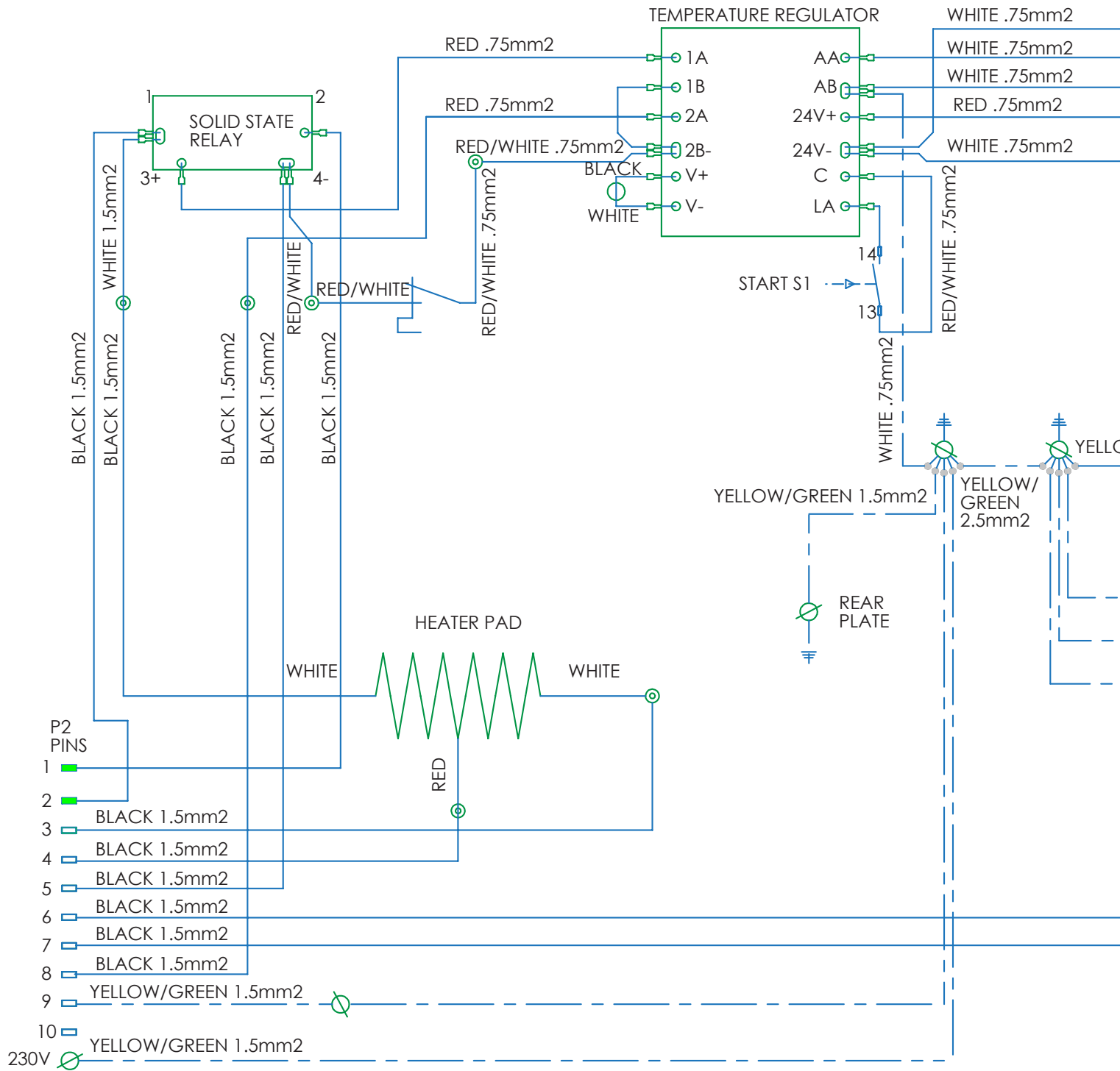

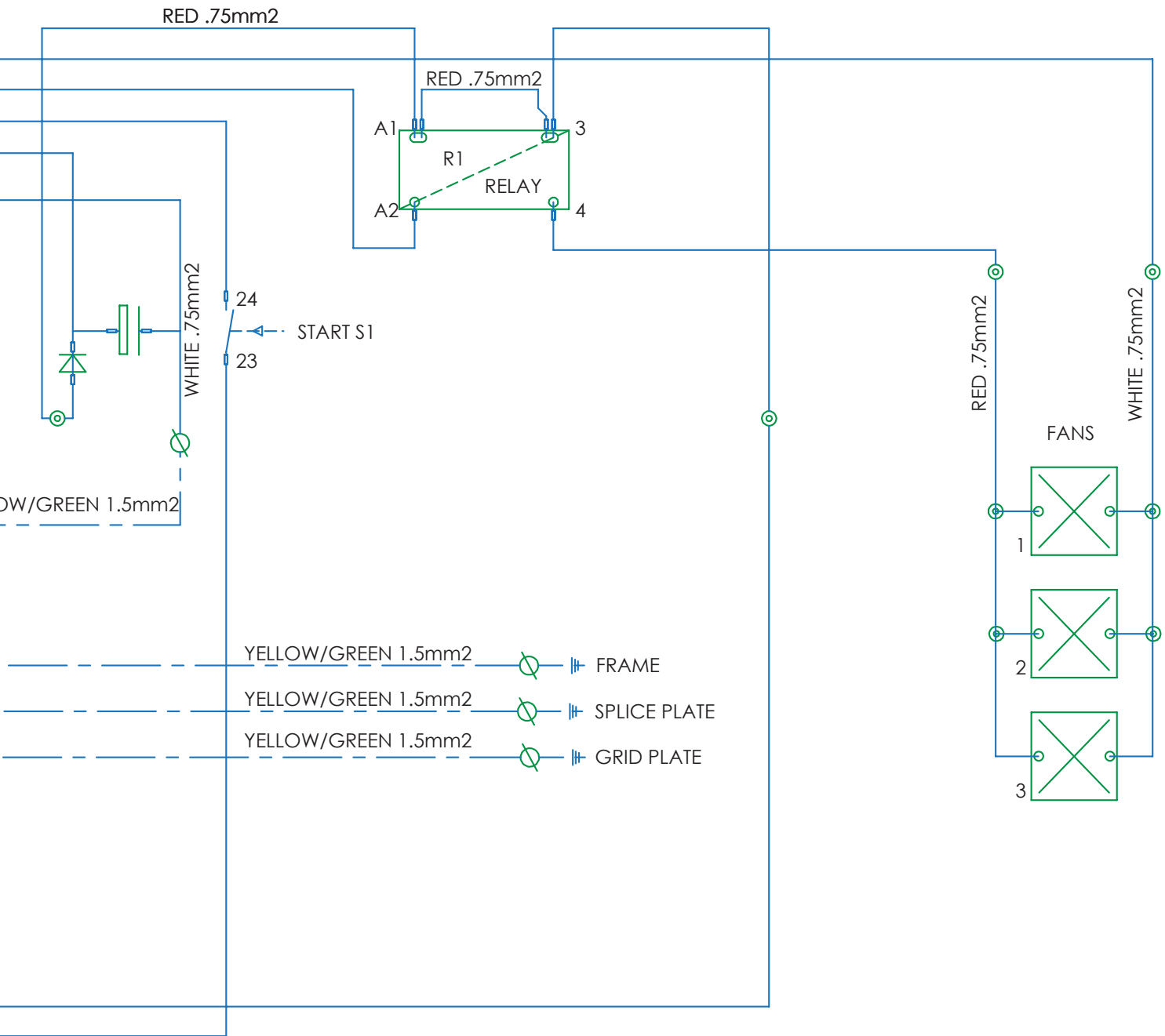

Electrical Schematics

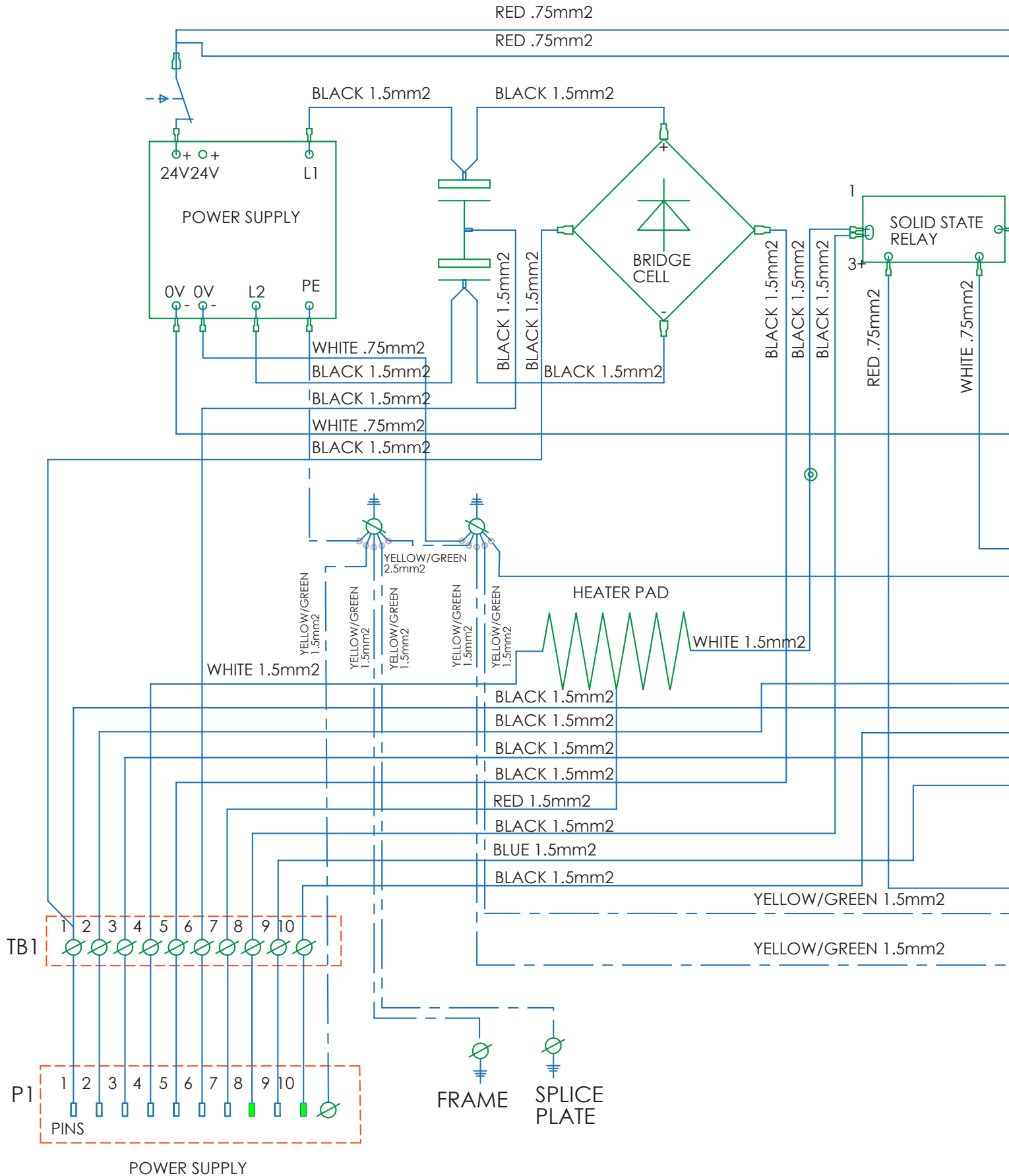

# Novitool® Aero™ Press Safety and Operating Manual

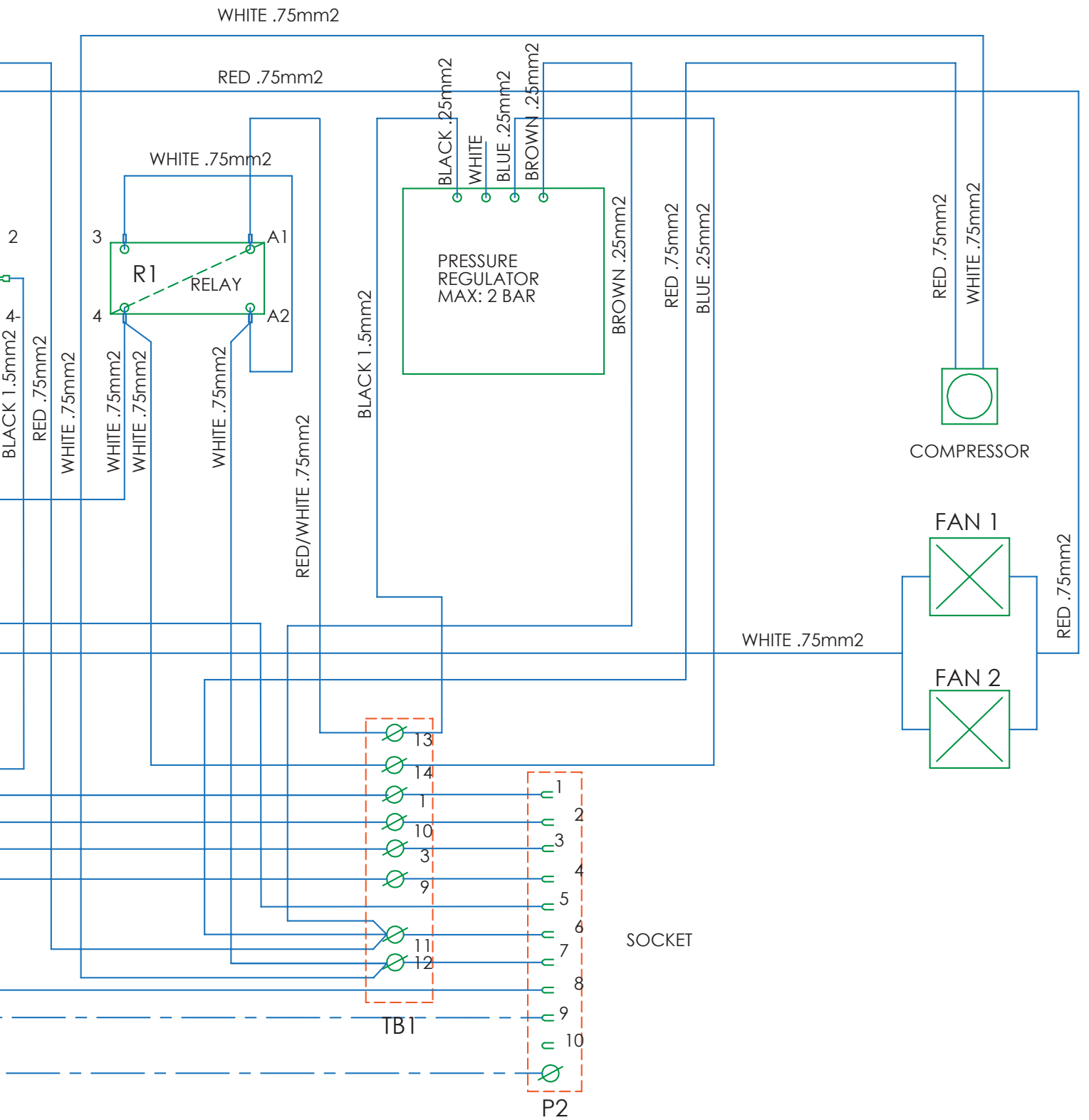

## Maintenance

### Settings of the pressure controller:

#### Resetting of the parameters to their original settings:

- Push and hold the **S** button to get into the function menu (display shows “F0” now)
- Push the **S** button one more time to get into the F0 menu (unit conversion menu)
  - The display should show “Uni” and “bAr” (bar) or “Psi” (psi) now. Setting can be done by pushing the UP ▲ or DOWN ▼ button
- Push **S** button to return to the function menu (display shows “F0”)
- Push the UP ▲ button to get to “F1”
  - (push **S**) “oU1” should be set to “HYS”
  - (push **S**) “lot” should be set to “I-n”
  - (push **S**) “n-I” should be set to “2.00”
  - (push **S**) “H-I” should be set to “0.02”
  - (push **S**) “Col” should be set to “Sor”
- F2 (not used)
- F3 “rES” should be set to “2.5”
- F4 “drE” should be set to “100”
- F5 “Pr5” should be set to “oFF”
- F6 (not to be changed)
- F7 “ECo” should be set to “oFF”
- F8 “Pin” should be set to “oFF”
- F90 “ALL” should be set to “oFF”
- F97 “Copy” should be set to “oFF”
  - If in the copy mode, push the ▲ and ▼ buttons simultaneously for some seconds to return
- F98 “tESt” should be set to “A”
- F99 “ini” should be set to “oFF”
- Push and hold the **S** button to return to the operation mode

### Calibration of the pressure controller

- Take care that the pressure in the AERO is completely released
- If the reading on the display is different than zero, continue as follows:
  - Push both the UP ▲ and DOWN ▼ button simultaneously and hold them for a while
  - The pressure controller is calibrated to zero; the display shows “0.0” now

### Reset of the 24 VDC fuse

- On the front of the panel there is a button “F”, to reset the 24 VDC fuse



# EC Declaration of Conformity

---

Flexco Netherlands  
Rooswijkweg 1-3  
1951 MH Velsen-Noord  
The Netherlands  
www.novitool.com

We, Flexco Netherlands, declare that the splice presses (Aero 300, Aero 600, Aero 900, Aero 1200, and Aero 1500) for splicing thermoplastic conveyor belt material, comply with the following EC Directives:

- Machine Safety Directive 2006/42/EC
- Low Voltage Equipment Directive 2006/95/EC
- Electromagnetic Compatibility Directive 2004/108/E

The Netherlands,  
Velsen-Noord,  
October 2010  
J.S. van't Schip



2525 Wisconsin Avenue • Downers Grove, IL 60515-4200 U.S.A.  
Tel: 1-630-971-0150 • Fax: 1-630-971-1180 • E-mail: [info@flexco.com](mailto:info@flexco.com) • Web: [www.flexco.com](http://www.flexco.com)

Australia: 61-2-9680-3322 • China: 86-21-33528388 • England: 44-1274-600-942 • Germany: 49-7428-9406-0  
India: 91-44-4354-2091 • Mexico: 52-55-5674-5326 • Singapore: 65-6281-7278 • South Africa: 27-11-608-4180

©2010 Flexible Steel Lacing Company. Flexco® is a registered trademark. 11-10. For Reorder: X2261

