

DIXON[®]

ZTR[®]
503

Operator's Manual



DIXON INDUSTRIES, INC
A BLOUNT COMPANY
AIRPORT INDUSTRIAL PARK
PO BOX 1569
COFFEYVILLE KS 67337 0945
316 251 2000
FAX 316 251 4117

BLOUNT

IMPORTANT - READ CAREFULLY

The Dixon ZTR Mower is both easy and fun to operate. However, any power mower must be operated properly to be safe. It is not a toy or a recreational vehicle. Before you start to use the mower, read the operator's manual carefully, and become completely familiar with the controls.

The information in this operator's manual applies to all Dixon ZTR Model 503 Mowers. Your Dixon dealer will gladly provide a check-out ride, and answer any questions.

See your dealer for warranty service, parts and repairs.

INDEX

1. SAFETY	Pages	1 - 3
2. WARRANTY POLICY	Page	4
3; SPECIFICATIONS	Page	5
4. SET UP AND SERVICE	Pages	6-11
5. OPERATION INSTRUCTIONS	Pages	12-13
6. CARE AND MAINTENANCE	Pages	14-20
7. TROUBLE SHOOTING	Pages	21-23
8. PARTS ILLUSTRATIONS	Pages	24 - 29
9. PARTS LIST	Pages	30 - 32

SAFETY

RIDING LAWNMOWERS, IF IMPROPERLY OPERATED. CAN CAUSE SERIOUS INJURY.

The following examples are the most common causes of injury to the operator or bystander.

1. BLADE CONTACT: The operator or bystander inserts a hand or foot into the discharge chute or under the mower deck and into the path of the cutting blade.
Never run the mower blades when there are people nearby.
Always turn the engine off when cleaning or working around the mower deck.
2. RUN-OVER: This situation occurs when a bystander is run-over or backed over by the "mower". The most frequently cited examples are with small children who wander into or are allowed to play, in an area where the mower is being operated. Never run the mower blades when there are people nearby, especially children. Young children should be indoors and watched by an adult. Always look behind you before backing up.
3. TIP-OVER: This occurs when the mower tips over, usually sideways or to the rear. This situation is due to operation of the mower on steep inclines or near a drop off.
Mow across the slope to slightly uphill.
Mow slopes when the grass is dry and watch for bumps, holes and other obstacles.
Test the slope with the blades off. A good rule of thumb is "Don't mow on a slope you can't back up". Stay clear of drop-offs, especially if they are on the down side of a slope.
4. THROWN OBJECTS: The fast spinning mower deck blade can strike stones or other objects which can be hurled into the path of a bystander. To prevent this from happening, never remove the safety discharge chute from the mower deck, or operate the mower when other people are around.
- 5- FIRES: Most accidents of this type occur during re-fueling of the mower or placing the mower in a storage situation. The exhaust system and related engine components operate at very high temperatures which can ignite any fuel spilled on or near them. Always allow the mower to cool before re-fueling or placing in storage.
6. OPERATION BY CHILDREN: This mower is not a toy or recreational vehicle.
Never allow children to operate the mower in any manner or to ride as a passenger.

NOTE: .The six examples are the most frequently cited injury causing situations. Please review all the safety precautions outlined on the following pages prior to operation of the mower. Our aim is to enhance the safe and satisfactory use of this product.

SAFETY REMINDERS: READ CAREFULLY BEFORE OPERATION

1. Wear appropriate, safe clothing when mowing - close fitting jeans or slacks and heavy leather or safety shoes with rough soles. Never operate this mower with bare feet or open sandals.
2. Do not operate on wet or slippery grass.
3. Always mow at the slowest speed that will cut satisfactorily.
4. Keep hands and feet away from the blade at all times.
5. Keep persons clear of the discharge chute. Do not operate mower unless deflector is in place.
6. When mowing hills or slopes, use extreme caution. Reduce speed, do not make sudden starts, stops or turns.
7. Always disengage blades before taking the mower across walks or objects that project above the surface.
8. Stay alert for holes, rocks and roots in the terrain, and other hazards. Keep away from drop-offs.
9. When the mower is not in use, turn the engine off and remove key. Never leave the engine running unattended. Your Dixon mower is equipped with a weight-sensitive switch that kills the engine when operator leaves the seat while blades are engaged.

Note: This important safety feature must be tested prior to each mowing. This may be done by starting engine, engaging blades and then ' rising slightly from seat. If engine does not stop, see your dealer for necessary repair.

10. Before adjusting or servicing your mower, turn off the engine and let it cool. Be sure all moving parts are stopped. Never run the 503 with the body open.
11. Never run the engine indoors; the fumes are dangerous.
12. Before backing your Dixon Mower; stop, turn around and look.
13. Handle gasoline with care - it is highly flammable.
 - A. Use approved gasoline container.
 - B. Never remove the fuel cap of, or add gasoline to, a running or hot engine, or an engine that has not been allowed to cool after running. Never fill the tank indoors and always clean up spilled gasoline.
 - C. Never store the mower, with gasoline in the tank, inside the building where fumes may reach an open flame or spark. Allow the engine to cool before storing in any enclosure.
14. Never lift lawnmower by the body; lift only by the frame.
15. Never carry passengers.

SAFETY REMINDERS; (continued)

16. Use care when pulling loads or using heavy equipment.
 - A. Use only approved drawbar hitch points.
 - B. Limit loads to those you can safely control.
 - C. Do not turn sharply. Use care when backing.
17. Watch out for traffic when crossing or near roadways.
18. Keep the mower in good operating condition, and keep safety devices in place and working.
19. Keep all nuts, bolts and screws tight to be sure the mower is in safe working condition.
20. To reduce fire hazard, keep the engine free of grass, leaves or excessive grease.
21. The mower should be stopped and inspected for damage after striking a foreign object or if it starts vibrating, and any damage should be repaired before restarting and operating the mower.
22. When mowing, proceed as follows:
 - A. Mow only in daylight or in good artificial light.
 - B. Shut the engine off when removing the grass catcher or unclogging chute.
 - C. Check the blade mounting bolts for proper tightness at frequent intervals.
 - D. Never operate the machine when using medication or under the influence of alcohol or drugs.

WARRANTY POLICY

Warranty Policy:

Each Model 503 is warranted against manufacturing defects in material and workmanship under normal use and service for a period of (1) year or (400) hours from date of purchase and is extended to the original retail purchaser of the mower only.

Obligation:

Under this warranty policy Dixon Industries, Inc., shall be limited to the replacement to the original purchaser of any part or parts, which within the warranty period shall be shown to be defective due to faulty workmanship or materials at the factory.

What is NOT covered by Dixon Industries, Inc.:

1. Pick up and delivery charges for transportation of mower to and from an authorized Dixon dealer's place of business.
2. Hydrostatic drive system adjustment.
3. Belts/cutting blades.
4. Engines. All engines used on Dixon ZTR mowers are warranted by each individual engine manufacturer.
5. Any charges relating to the renting or lease of equipment while repair work is being performed on a warranted mower.
6. Negligence. Repairs caused by negligence, improper use or abuse on part of owner or operator.

Who is authorized to perform warranty service?

Any authorized Dixon ZTR dealer can perform repairs under warranty on our mowers.

If warranty repairs are needed, please contact the selling dealer first. If, due to circumstances beyond your control, you are unable to obtain repairs by the selling dealer, contact the Customer Service Department of Dixon Industries, Inc., for assistance.

Product updates or improvements:

We reserve the right to make changes in design or improvements on our products without imposing any obligation upon ourselves to install the same on products heretofore manufactured.

WARRANTY REVISED
REFER TO WARRANTY REGISTRATION
FORM D/I/N 8200 FOR DETAILS ON
RESIDENTIAL USE (2 YEAR)
LIMITED WARRANTY POLICY

SPECIFICATIONS

Chassis: 11 GA - rectangular tube.

Body: Two piece - made of DR acrylic reinforced with fiberglass, color fast, scratch and impact resistant. Front body contains access panels for battery service and engine to mower deck belt removal. Rear body tilts up to allow service on the entire drive system.

Seat: Economically designed for operator comfort by use of high density closed cell foam, contoured back rest and arm rests. Seat is adjustable fore and aft.

Mower Deck: 12 GA stamped steel construction, (3) blades, 50" cut width, cut height 1" to 4" via 7 position lift handle. Self cleaning design, smoothly curved front, aides discharge of grass.

Blade Drive: Warner electric clutch.

Drive System: Each rear wheel is independently driven by a Sundstrand BDU-10L Series 70 hydrostatic transmission, which is powered by a permanently lubricated Peerless gearbox. The hydrostatic transmissions, in turn, power a fully enclosed Agri-Fab gearbox. The gears in the Agri-Fab gearbox are permanently lubricated using a special grease which completely eliminates the need for any type of maintenance.

The Sundstrand BDU-10L Series 70 hydrostatic transmissions are serviced with any high quality (10W-30) motor oil. The oil is filtered by a (10) micron oil filter. Recommended service interval for both oil and filter is after the first (150) hours of operation, then after every (400) hours of operation, unless the system has been contaminated by dirt or other foreign debris.

Engine; 20 HP Onan Twin Cylinder with cast iron cylinders, pressure lubrication and vacuum powered pulsating diaphragm fuel pump.

Starting System: Electric by key switch operation with safety interlocks on parking brake and blade drive clutch.

Tires: Front 11 x 4.10 x 5, smooth thread.
Rear 20 x 10 x 8, turf savers.

Capacities: Fuel - 4.8 gallons total (dual tanks) with fuel gauges.
Hydrostat oil tank - 3 quart with inline (10) micron filter.
Hydrostat oil recommendation - name brand SAE (10W-30) motor oil.

Dimensions: Width - 60"
Height - 45"
Length - 72"
Weight - 630 Ibs.

NOTE: Additional Information provided in strvlci Instructions under the Individual component.

SPECIFICATIONS SUBJECT TO CHANGE WITHOUT NOTICE.

1. Seat assembly instructions.
2. Upper control lever installation.
3. Mower deck installation.
4. Deck leveling procedure.
5. Final preparation.

SEAT ASSEMBLY INSTRUCTIONS

1. Assemble seat as shown in picture. Do not fully tighten the bolts -,-'hich secure left and right arm rest brackets to seat bottom until seat back and tool box are installed. This will aid alignment of all parts.
2. Place seat assembly on rear body cover, connect seat safety switch.
3. Insert the (2) rear studs of the seat slide into the rear holes of the body cover. Firmly hold seat assembly against body cover with one hand while rear body is raised to fully open position. Continue to hold seat against body to prevent damage to seat safety switch wiring.
4. Install (1) flat washer and (1) nylok nut on (1) of the rear studs extending through body cover and seat frame, tighten a few threads to hold seat assembly in place.
5. Position seat on front holes and install all remaining washers and nylok nuts. Tighten all nuts fully.

SEAT ASSEMBLY INSTRUCTIONS SEAT

KEY	QTY	PART NO	DESCRIPTION
1	1	4415	SEAT BOTTOM ASSEMBLY
2	1	4385	SEAT BACK
3	2	4400	ARM REST
4	1	4401	ARM REST BRACKET L.H.
5	1	4402	ARM REST BRACKET R.H.
6	1	425E	UTILITY BOX ASSEMBLY
7	14	3020	5/16 STD. FLAT WASHER
8	14	3224	5/16-18 x 3/4 HHB GR5 W/MYLOK
9	4	3205	5/16-18 HEX NUT W/MYLOK
10	2	3722	FIBRE WASHER
11	2	3033	1/2" FLAT WASHER - NARROW
12	2	3035	1/2-13 HEX JAM LOCKNUT
13	2	357B	NYLON BUSHING

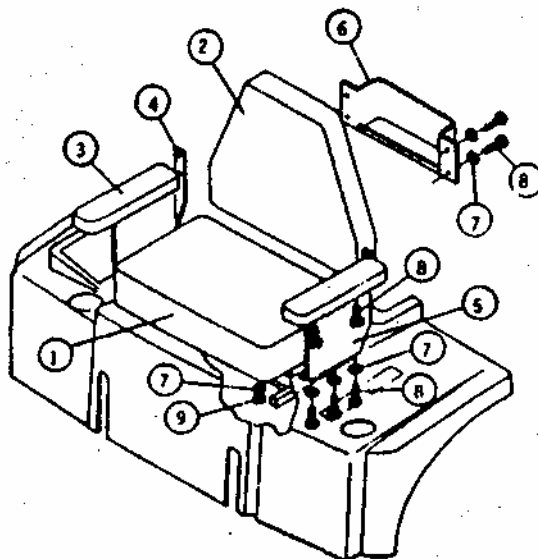

NOTE: HARDWARE FOR CONTROL LEVER ASSEMBLY

UPPER CONTROL LEVER INSTALLATION

1. Raise rear body cover to fully open position.
2. Install flat washer on right hand swivel plate weldment. Next install right hand control lever, then second flat washer.
3. Push control lever into the neutral slot and install (2) cup washers, (1) flat washer and jam nut. (See Illustration)
4. Tighten jam nut. Proper tightness or tension on jam nut is achieved when swing out movement of upper control levers requires some pressure. Levers should not fall to the side or be sloppy in movement.
5. Repeat above procedure on left side.

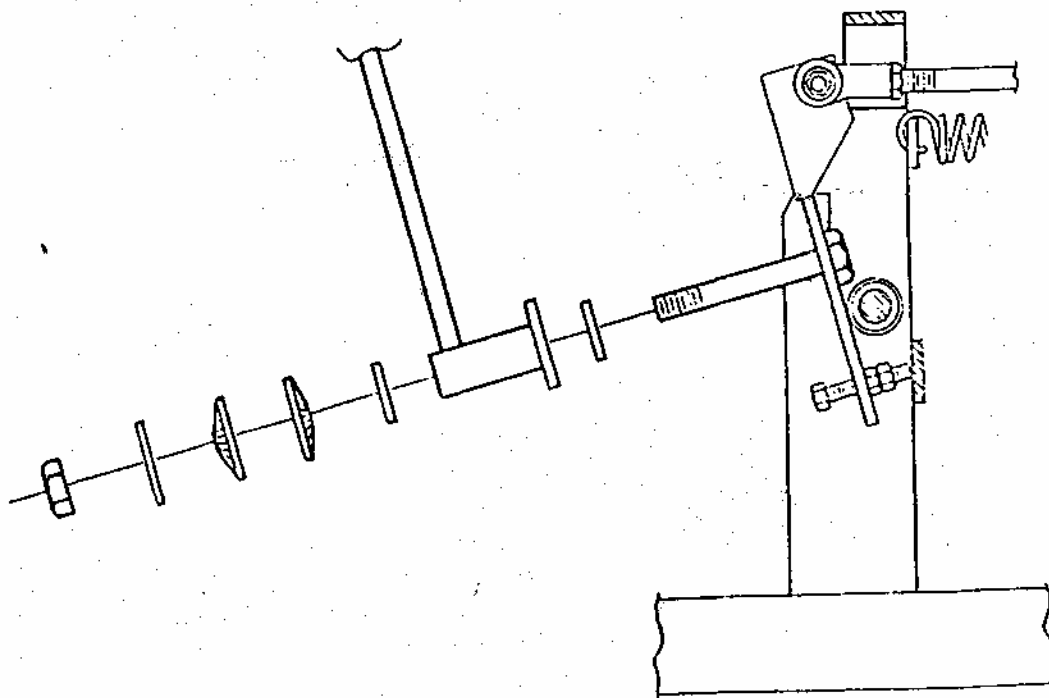

1. To remove front body from chassis, disconnect headlights and remove acorn nut in middle of body.
2. Install rear hanger rods on lift frame, as shown in the diagram. Slide lift plate on hanger rods, small holes in lift plate will face rear of mower and start nylok nuts on each hanger rod until approximately 1/4 inch of threads are exposed.
3. Position mower deck under chassis.
4. Place lift lever in 3rd hole from highest cut, position #5 on quadrant.
5. Using (1) of the deck support rods, Insert the rod at the corner of the lift frame and the front of the mower chassis in the groove provided on the lift frame. Pry backwards on the lift frame enough to connect the brake link into the hole on the tab of the lift lever. This will allow for belt installation in step #7.
6. Raise mower deck at the rear and slide (1) of the deck support rods through the mower deck lift plate and the tabs of the mower deck. "Note" A length of 2 x 4 board turned on end and placed under the mower deck for support will make this task easier if the installation is being done by one person, due to the weight of the mower deck.
7. Raise front of mower deck and slide front support rod through lift frame and tabs on mower deck. Install hair pin clips on front and rear support rods.
8. Move lift lever to lowest cut position, install engine to mower deck drive belt on top center pulley. Check belt routing after installation to make certain that belt is centered in groove of electric clutch pulley.
9. Move lift lever toward high cut position and remove brake link from hole on lift lever.
10. Install deflector chute on mower deck by using nuts and bolts provided.
Never operate mower without deflector chute in place.

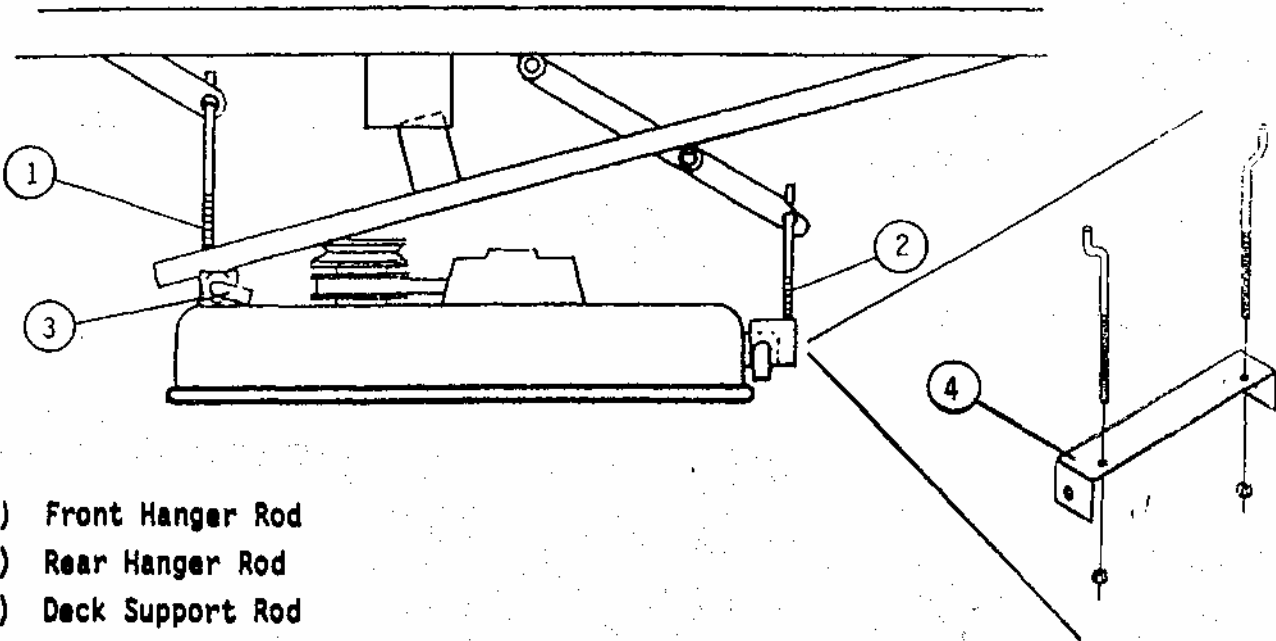

- (1) Front Hanger Rod
- (2) Rear Hanger Rod
- (3) Deck Support Rod
- (4) Lift Plate

MOWER DECK LEVELING PROCEDURE

Leveling Principals:

- A. There are a total of (4) threaded adjusters which will control the attitude or pitch of the mower deck. The adjusters have lock nuts on the bottom which can be turned up or down to raise or lower the front and rear of the mower deck. Deck should be level or pitched slightly higher in rear.

Leveling the Deck:

- A. Place the mower on a smooth level surface, check tire pressures to insure the mower has a correct stance. Inflate tires as required:
 - Front - (40 - 46 Ibs. maximum)
 - Rear - (20 - 24 Ibs. maximum)
- B. Remove the discharge chute from the mower deck. Rotate or turn each outer blade tip to align with the edge of the deck or side to side.
- C. Measure from the surface up to the bottom of the blade tip on the discharge side of the mower deck. Retain this measurement. Move to the opposite side and check that measurement is the same. If adjustment is required, turn the nut on the bottom of the front threaded adjuster up or down until both side to side measurements are equal. Retain measurement.
- D. Rotate or turn both outer blades to align with the deck in a front to rear manner. Move to the left rear threaded adjuster, "left rear is designated from operator position on the mower". Turn adjuster nut up or down until rear of mower deck is positioned level to 1/8th of an inch higher than the side to side measurement. At this time, the mower deck will hang or be suspended on (3) points. Move the right rear adjuster and take out the slack which will be present by turning adjuster lock nut up. Confirm the measurement used on the left rear of the deck. Re-install discharge chute.

NOTE:

This will place the mower deck in a base measurement position. Additional adjustment may be required to achieve desired cut for the type of grass or conditions being mowed.

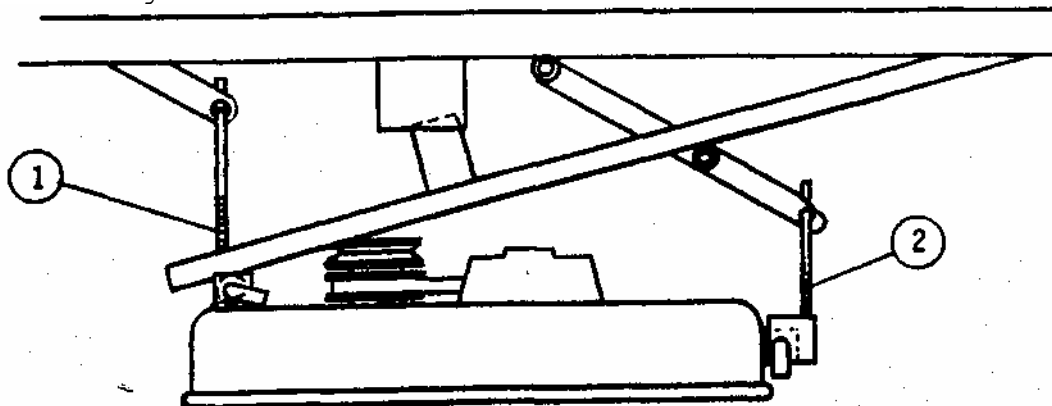

(1) - (2) Adjustment Points

FINAL PREPARATION

1. Remove battery from chassis.
2. Fill each cell with electrolyte (acid) to ring at bottom of fill cap.
3. Allow battery to Sit for (10) minutes, re-check acid level and top off any cells that are low.
4. Trickle charge battery using a charger of less than (8) amps until all cells are gassing freely. Hydrometer readings may be taken, if desired
5. Install permanent battery caps and wash any accumulated acid from battery before re-installation on chassis.
6. Observe proper battery polarity when re-connecting leads on chassis. Aiwcy¹; connect positive lead first.

Engine Service:

1. Final preparation of engine should be completed using engine service manual provided with mower.

Initial Start and Hydrostat Transmission Check:

1. Final hydrostat checks have been performed at the factory, however, it is necessary to check that the pressure relief bypass on each hydrostatic transmission is completely released before attempting to drive mower.
2. Each hydrostat has a bypass relief pin located at the rear of each hydrostatic unit. A bypass keeper is provided to allow the mower to be rolled around without complete servicing of the unit. To accomplish this, the bypass keeper must be positioned to depress the bypass relief pin. After the use of bypass keeper, each must be removed from the bypass relief pin before the unit can be operated.

OPERATION INSTRUCTIONS

The safe and successful operation of the Model 503 will depend upon the operator having the correct knowledge of all controls used on the mower and making good judgments about the terrain to be mowed. Never allow anyone to operate the mower without complete knowledge of all controls and their functions.

Sound judgment by the owner will prevent accidents.

Controls and their functions. All controls described from operators position.

PARKING BRAKE:

The parking brake used on the Model 503 is designed to hold the mower from moving and is not intended for use in stopping the mower while it is in motion. An additional safety feature of the parking brake is that the engine cannot be started unless the brake is applied.

THE HYDROSTATIC DRIVE SYSTEM:

Allows the mower to turn on its own axis (zero radius). Each lever controls one side of the mower. The pressure required to operate the mower is very light and a minimum of 1/2 hour should be spent simply driving the mower in a non-mowing application to gain the confidence necessary to mow like a pro.

LEVER MOVEMENTS:

No shifting or clutching required.

TO GO FORWARD:

Release parking brake. From neutral position, gently push both drive levers forward; to increase speed, move levers farther forward.

TO GO BACKWARD:

From neutral position, gently pull both drive levers toward you.

TURNING:

Turning is controlled by moving one drive lever slightly forward or rearward of the other. To turn left, move left lever rearward of right lever. To turn "square corners" move lever of desired direction to neutral. To turn on mower's own axis (zero radius) reduce speed and move one lever to reverse position and the other to forward position.

BRAKING:

To brake mower, move both levers in direction opposite of travel, release levers to neutral, set parking brake. When stopping on incline, it may be necessary to hold slight pressure on levers in direction opposite of slope until parking brake is set.

GROUND SPEED:

Ground speed (controlled by movement of hand levers) must be carefully controlled for safety and best mowing results. Never operate at high speed in unfamiliar areas or on slopes.

CHOKE CONTROL LEVER:

"Used to start a cold engine. (Engine has not been operated for a length of time. Located on control panel to operators right.

OPERATION INSTRUCTIONS (continued)

THROTTLE CONTROL LEVER:

Controls engine speed, has positive detent in fully opened position to insure adequate cooling of the engine and maintain mower deck blade speed in a mowing application. Throttle will automatically return to idle position if not locked into the positive detent located on control panel to operator's right.

MOWER DECK CUT HEIGHT LIFT LEVER:

Controls the cutting height of the mower deck. Seven positions of adjustment in which the very top, or highest notch, is used for transporting the mower in a non-mowing situation. Located in front of operator on the right side of mower.

BLADE DRIVE:

To engage the mower deck cutter blades, lift switch up lightly and push forward. To disengage blades, pull switch backward. Switch is clearly marked "on and off".

LIGHT SWITCH:

The headlights are activated by pushing the switch forward. Failure to turn off the lights, once the engine is stopped, will result in rapid discharge of the battery.

FUSE BLOCK:

Protection of the electrical system is by (1) 15 AMP fuse. To remove the fuse for inspection, just simply lift upon fuse block lid. If fuse burns quickly, please consult your dealer for inspection and repair. Never attempt to bypass the fuse by any method.

CARE AND MAINTENANCE - MODEL 503

This portion of the Model 503 owners manual deals with normal service items which can be performed by the owner. Please remember that if you are in doubt as to the correct service procedures to be followed, these and other service situations can be handled by a Dixon ZTR Dealer who is familiar with the service of your mower.

NOTE:

The disassembly and repair of the Sundstrand BDU 10 L hydrostatic transmissions is best left to a qualified Sundstrand repair and service facility. These repair centers are equipped with the necessary tools and service information to accurately perform all service required. Due to the precision nature of these transmissions, field repairs cannot be recommended.

MAINTENANCE SCHEDULE:

To insure a long and trouble free service life on all the components used on the Model 503 a regular and thorough maintenance schedule should be followed. As with any type of precision made equipment, a certain amount of initial bedding in or seating of the components will take place. The following items should be checked after the first (10) hours of operation and on a weekly basis, or each (40) hours of use:

1. Drive system, belts and controls.
2. Mower deck belts
3. Tire pressures.
4. Hydrostat oil.
5. Tightness of all nuts and bolts.

Refer to engine service manual provided with your mower for maintenance schedules and procedures to be used on the engine.

CARE AND MAINTENANCE - MODEL 503

MOWER DECK SERVICE: CUTTER BLADE REMOVAL - BELT TENSION.

"CAUTION" The removal of the cutter blades for either sharpening or replacement is best accomplished by removing the deck assembly from the mower. Do not attempt to raise or lift the front of the mower unless proper safety equipment is available to support the mower. If you do not have the necessary equipment, entrust this task to your dealer.

DECK REMOVAL:

1. Remove front belt access cover from body. Stand in front of the mower, grasp lift quadrant lever with left hand. Move lever to align with the (5th) hole from the bottom on the quadrant plate. At this time, connect brake link into hole on lift lever. Move lift lever toward lowest cut position and remove belt from the top of center deck hub assembly,
2. Remove the hair pin cotters from the ends of the deck support rods. Slide deck support rods from deck while supporting deck assembly with a suitable brace, or by the use of an assistant to hold the deck while rods are removed. Slide deck from under chassis.
3. Reverse procedure to re-install deck assembly.

CUTTER BLADE REMOVAL:

1. Carefully place deck assembly in a manner which will allow access to the blade bolts. Hold blade from turning while bolt is removed from the center of each hub assembly. "Caution" wear heavy, thick gloves when holding onto cutter blade, avoid the sharp edge of the blade.
2. When re-assembling blades to hub assemblies, fully tighten blade bolts to a minimum of (35 ft. lbs.) torque. The use of air impact tools is recommended for installation to insure bolt tightness.

BELT TENSION:

1. The engine to mower deck drive belt on the Model 503 is automatically held in proper tension by springs which push the deck assembly forward, and does not require any additional adjustment to be made. Both the belt and the idler system should be periodically inspected due to the nature of the job they perform.
2. Serpentine deck belt tension is maintained by a manual adjustment rod which is located on the top of the mower deck assembly. Proper belt tension is critical to insure cut quality. If adjustment is required, tighten lock nut on adjustment rod until belt free play or movement between pulleys is approximately 1/4 of an inch.

(1) FORWARD LEVER STOP
ADJUSTMENT

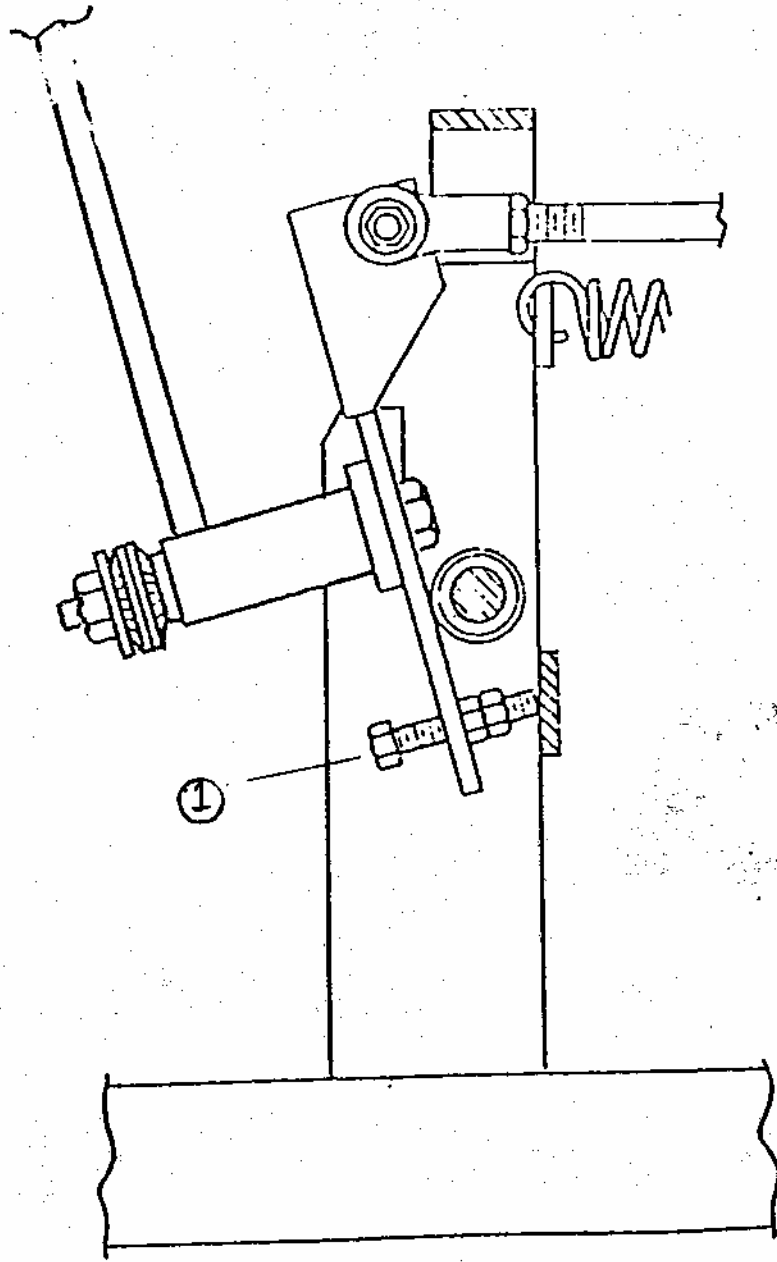

CARE AND MAINTENANCE - MODEL 503

LUBRICATION:

CHASSIS AND MOWER DECK: Number of grease zerks used (2)
LOCATIONS: (1) each front wheel caster
SERVICE INTERVALS: Every (50) hour? of operation
RECOMMENDED GREASE: Name brand wheel bearing or multi-purpose grease

CAUTION: The use of compressed air pressure greasing methods is not recommended as damage to seals and bearings could occur.

Using a hand pressure grease gun, lubricate each front caster to allow even distribution of grease within the caster, rotate or spin each front wheel caster after (3) pumps of the grease gun. Repeat process until the appearance of grease is noted completely around each caster.

ENGINE OIL CHANGES: "Refer to separate owners manual furnished by
OIL RECOMMENDATIONS: the engine manufacturer."
SERVICE INTERVALS:

Please dispose of used oils at proper collection centers. Protect your environment.

CARE AND MAINTENANCE - MODEL 503

CLEANING THE MOWER:

A clean machine is a source of pride to the owner. However, cleaning by use of high pressure commercial washes is not recommended. The high water pressure, combined with solvents or alkaline detergents, can lead to corrosion of electrical components or damage to the sealed bearings used on your mower. A better approach is the use of mild household soaps and low water pressure. A stiff brush can be used to loosen excess grass and dirt build up. Avoid directing water pressure onto the mower deck hub assemblies, electrical wiring and engine components such as air filter openings.

To remove excess water which accumulated during washing of the mower, either blow off with compressed air, if available, or start the engine, allowing a long enough operation time to dry thoroughly. It is advisable to engage the mower deck for a short time to disperse all water from pulleys and belts.

Please help protect the environment by avoiding all chemicals which may damage or cause harm to plants and animals in your area.

TROUBLE SHOOTING

MOWER CUT QUALITY:

There are many variables that can effect the cut quality of any multi blade mower. Type and condition of grass, ground speed, blade speed, and conditions are some of the variables that interact creating differences in cut quality results. In most cases, a smooth, even cut will be achieved without further adjustment.

The Trouble Shooting Chart suggests practices and adjustments that may be helpful in improving cut quality. Your Dixon ZTR Dealer is also available to provide assistance to you.

<u>SITUATION</u>	<u>CAUSES</u>	<u>REMEDY</u>
Poor cut quality	Ground speed	Reduce mowing speed
Poor cut quality	Loose belts	Adjust per operators manual
Poor cut quality	Engine RPM too low	Increase engine RPM to maximum
Poor cut quality	Dull or bent blades	Sharpen or replace as required
Poor cut quality	Unlevel mower deck	Adjust per operators manual
Poor cut quality	Grass build-up under mower deck	Clean out underside of mower deck
Poor cut quality	Improper blades	Replace with original equipment blades which are designed for the Model 501
Poor cut quality	Uneven tire pressures	Check and adjust as required per operators manual

TROUBLE SHOOTING**Drive System:**

<u>SITUATION</u>	<u>CAUSES</u>	<u>REMEDY</u>
Mower pulls to one side or the other	Drive adjustment	Adjust per operators manual Consult your dealer for repair
Loss of drive power on one side or the other	T-Box belts slipping	Adjust per operators manual Consult your dealer for repair
Loss of power on both wheels after being operated for a length of time	Belt from engine to T-Box is slipping	Adjust per operators manual Consult your dealer for repair
Poor driving performance	Operation of mower	Review operators section of owners manual
Oil leaks	Loose or missing hose clamps	Tighten or replace as required

TROUBLE SHOOTING

ELECTRICAL SYSTEM:

SITUATION	CAUSE	REMEDY
Starter will not turn engine over	Blown fuse	Inspect and replace fuse If fuse continues to burn consult your dealer for repair
Starter will not turn engine over	Dead battery	Charge battery
Battery discharge	Poor connections on battery Battery water low Wrong battery Installed in mower	Tighten or replace as required
Battery discharge	Engine electrical system not functioning correctly	Have electrical system checked by your dealer
Battery discharge	Engine being operated at too low an RPM	Increase engine RPM Consult your dealer for information
Electric clutch will not engage mower deck blades	Low battery condition Poor connections on clutch switch Broken wiring	Repair or replace as required Consult your dealer for repair
Head lights do not operate	Poor connection on lights Broken wiring Bad bulb	Repair or replace as required

Note:

Electrical system failures are generally simple in nature, always check the obvious first and then move onto the more complicated parts used. Poor battery service, loose connections, corrosion, frayed or broken wiring, are more likely than component failure.

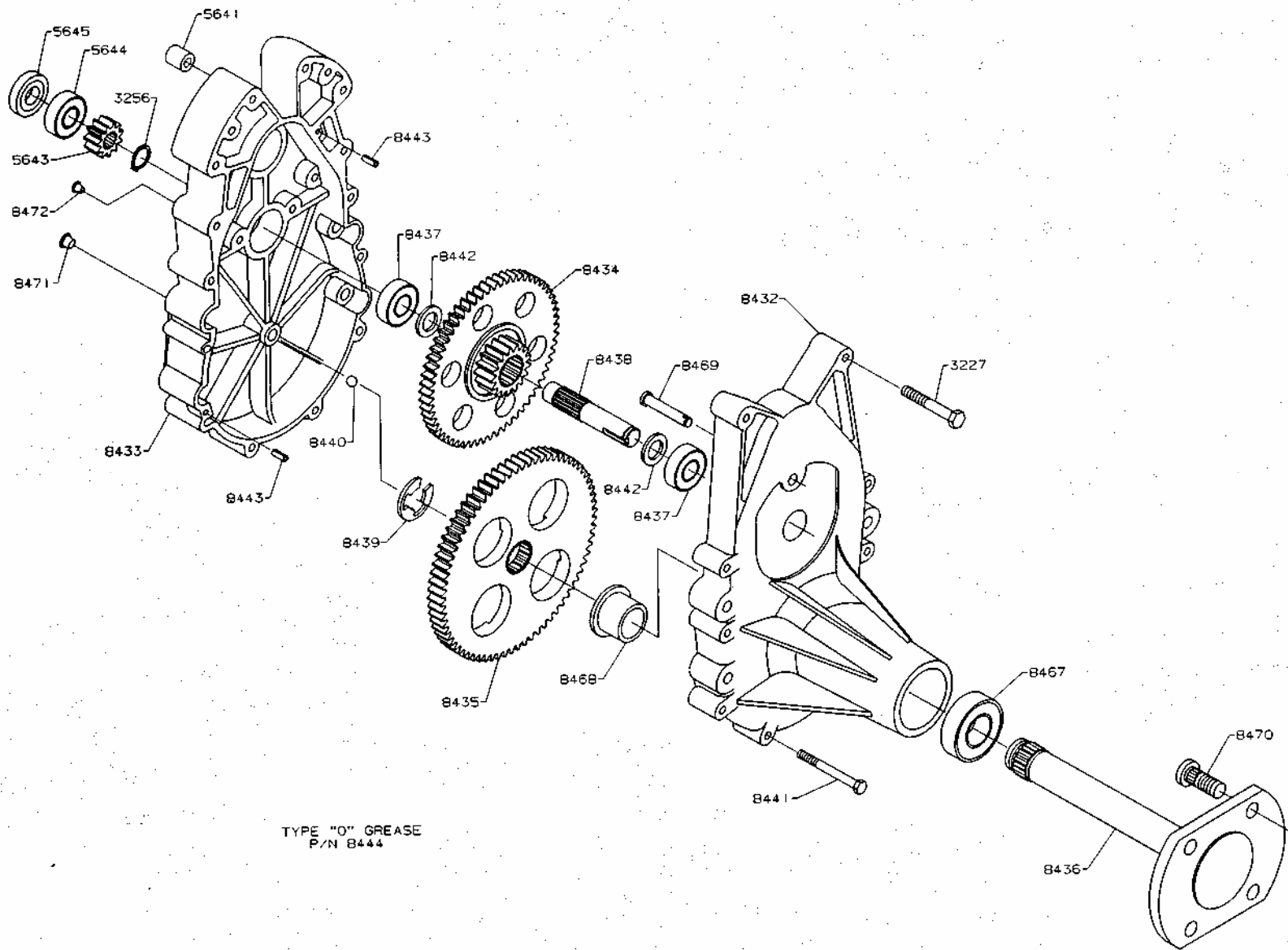

1993 500 Series Gearbox Assembly

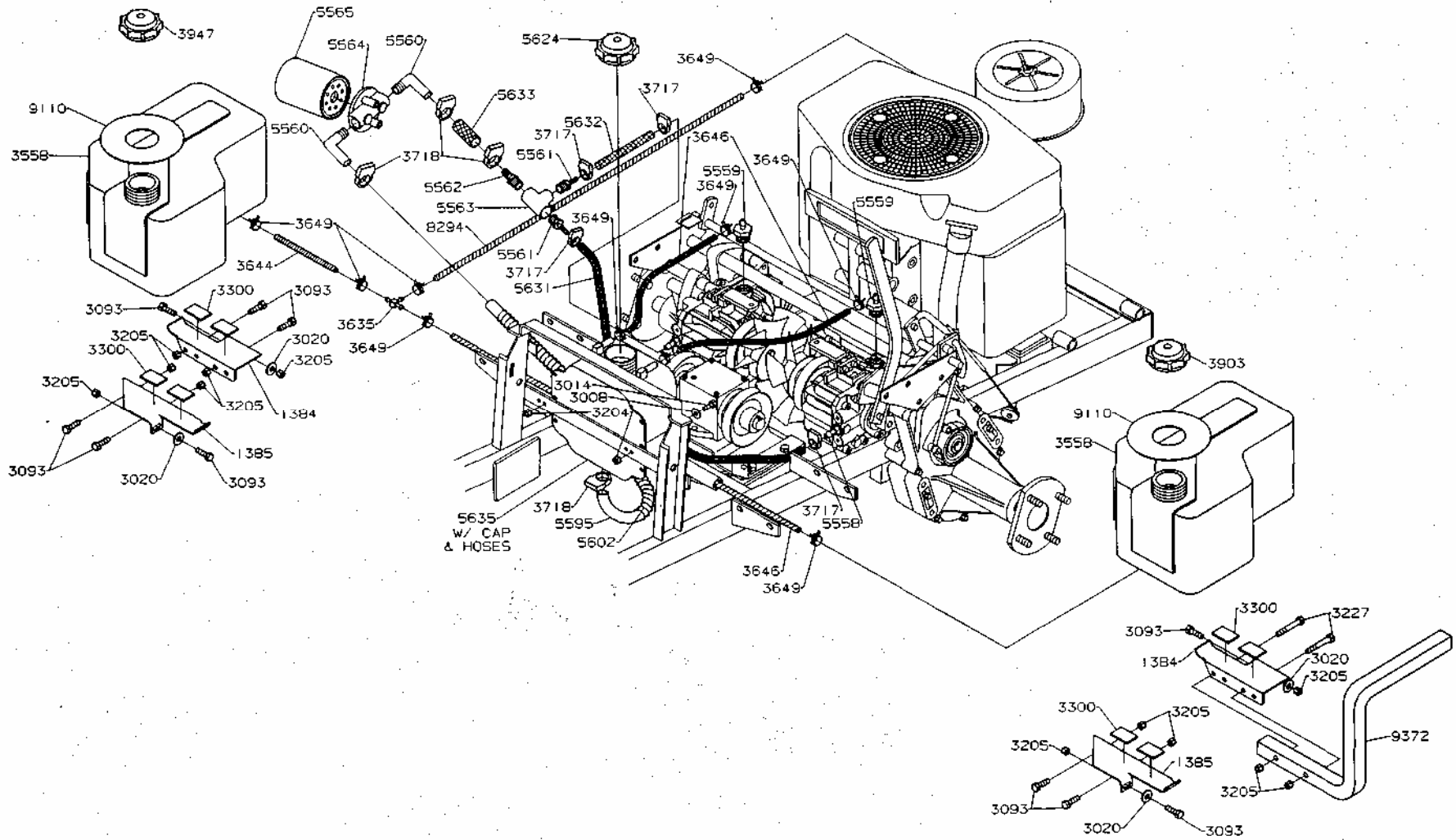

1993 Fuel & Hydraulics Tanks & Fittings Assembly Model ZTR 503

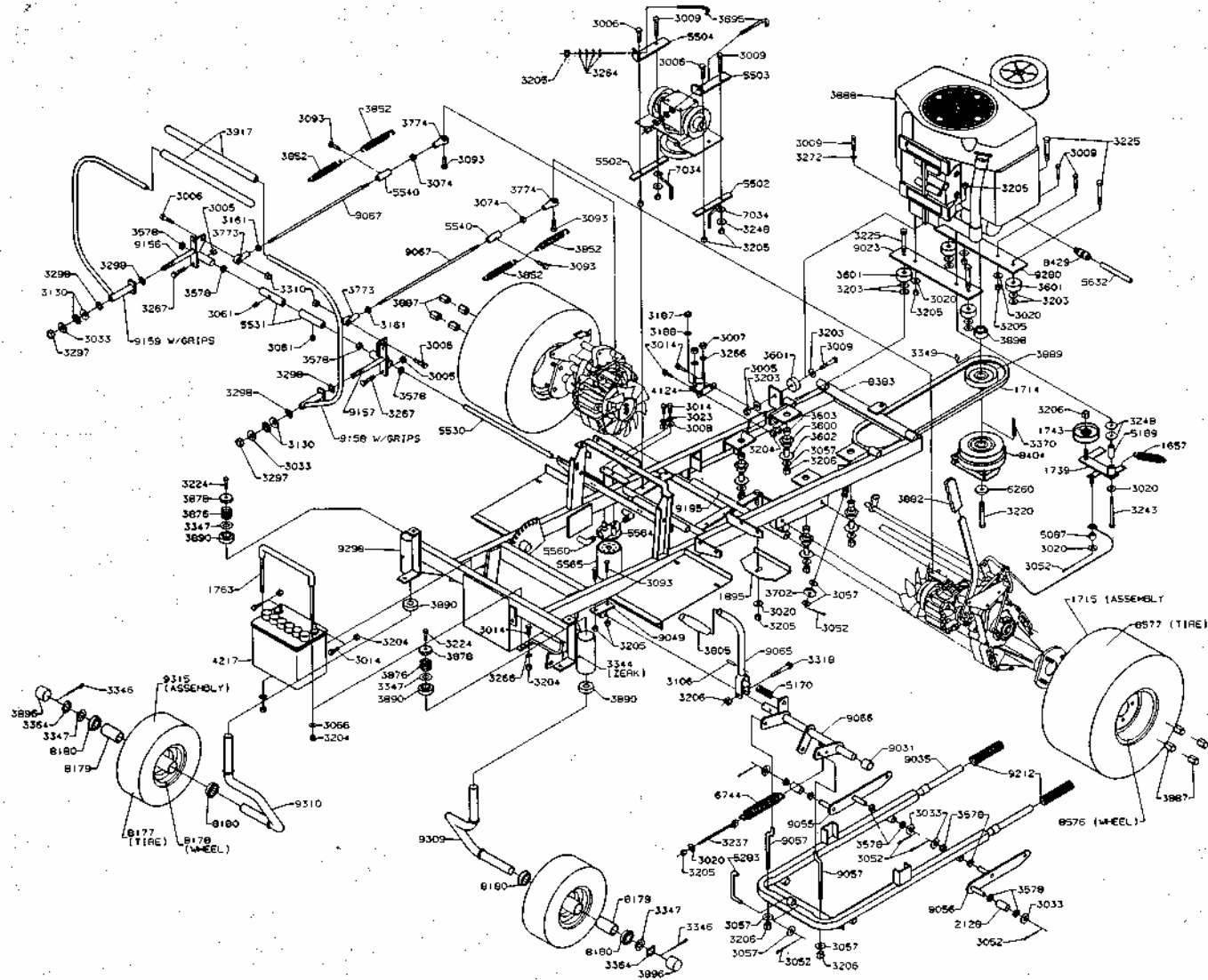

1993 Chassis Assembly Model ZTR 503

1993 Body Assembly Model ZI R 503

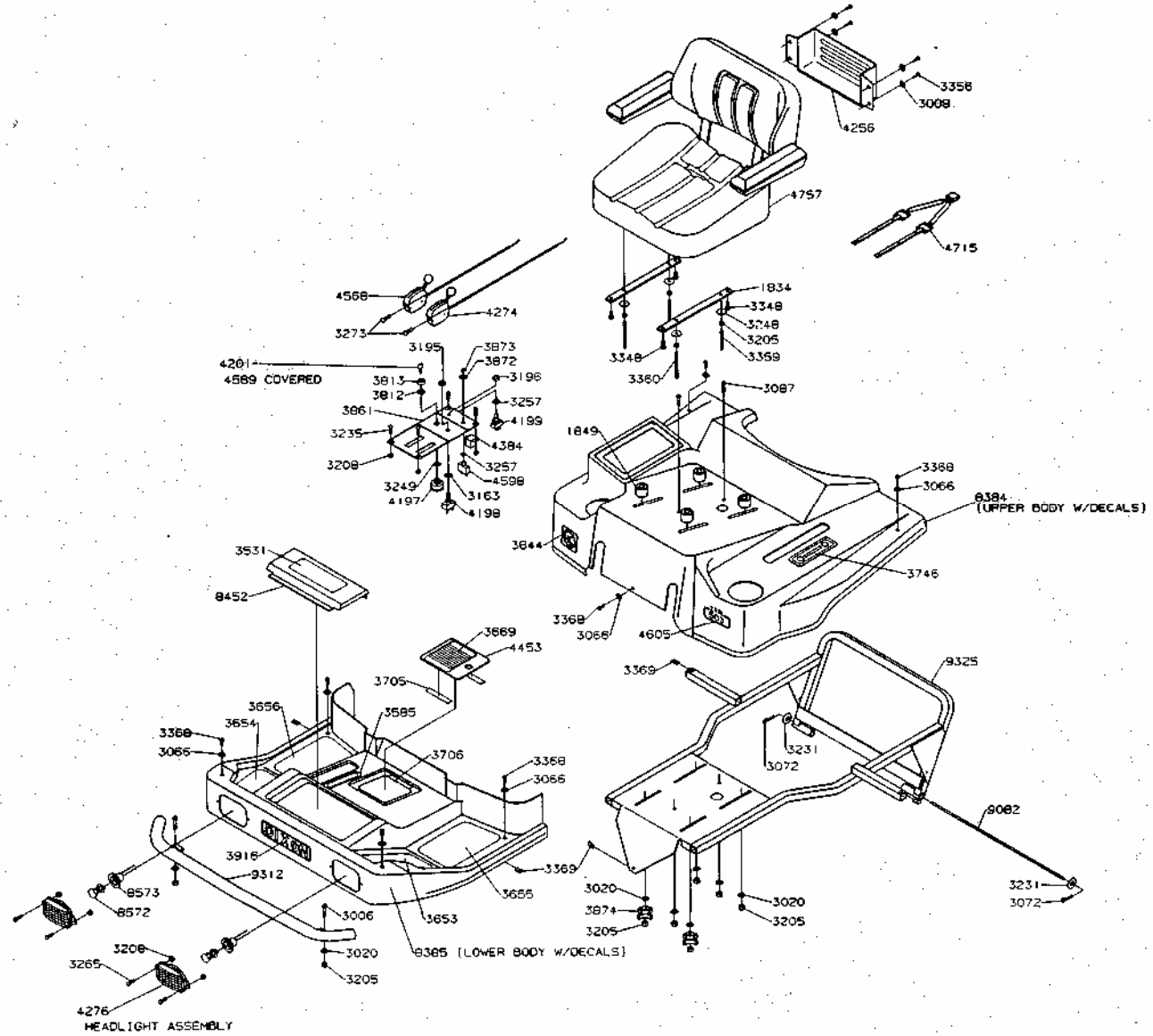

1300	Belt	3140	1/4" ID Disc Spring
1384	Tank Mount Bracket (Short)	3145	Washer .170 I.D.
1385	Tank Mount Bracket (Long)	3161	5/16"-24 UNF Nut LH Thread
1469	LH Slide Angle	3163	1/2 " Int Tooth Lock Washer
1470	RH Slide Angle	3169	3/8"-16 X 1" HH Bolt Gr 5
1471	Seat Slide	3175	1/2"-13 X 1-1/2" HH Bolt
1627	3/8" Pipe Elbow	3178	3/8"-16 X 2-1/2" HH Bolt Gr 5
1657	Spring - Belt Idler	3182	Flip Lock Bushing
1668	Drive Pulley	3184	5/16"-18 X 1-1/4" Pan Hd Phillips Screw
1675	Clutch Anchor	3186	#12-14 X 1" Drill & Tap Screw
1682	L-Rod	3193	Washer .43 X 1.38 X .25
1701	Wheel/Deck Hub Bearing	3195	Face Nut 1/2"-27
1714	T-Box Drive Belt	3196	Face Nut 7/16"-28
1715	Rear Wheel & Tire	3203	3/8" ID Flat Washer (Narrow)
1732	Pulley - T-Box	3204	1/4"-20 Hex Nut w/Nylok
1733	Pulley - T-Box	3205	5/16"-18 Hex Nut w/Nylok
1734	Pulley Hydrostat	3206	3/8"-16 Hex Nut w/Nylok
1739	Hydrostat Idler Bracket	3208	#10-24 Hex Nut w/Nylok
1743	Hydrostat .Flat Idler Pulley HD	3220	7/16"-20 X 2-3/4" HH Bolt Gr 5
1745	Pulley	3224	5/16:-18 X 1" HH Bolt w/Nylok Gr 5
1752	Plastic Idler	3225	3/8"-16 X 2-1/4" HH Bolt
1763	Tie Down w/Insulator	3228	5/8"-11 X 6-1/4" Carriage Bolt
1765	V-Belt	3231	9/16" Std Flat Washer
1801	Seat Strap	3235	#10-24 X 5/8" Phillips Pan Hd Screw
2128	Sleeve	3237	Eye Bolt 5/16" X 6.00
2164	Support Sprocket Spacer	3243	5/16"-18 X 3-1/4" HH Bolt Gr 5
2173	Bushing	3245	3/8"-16 Thin Prof Nylok Nut
2928	3/16" X 1" Key	3247	#6-20 X 1/2" Phillips Pan Hd Screw
3002	5/16" - 18 X 2i HH Bolt Gr 8	3248	5/16" ID X 1/8" Thick Washer
3003	5/16" - 18 UNC X 1j" HH Bolt Gr 5	3257	7/16" Int Tooth Lock Washer
3005	5/16" - 18 UNC Hex Nut	3260	1/4"-20 X 1/2" HH Bolt Gr 5
3006	5/16" - 18 X U" HH Bolt Gr 5	3263	5/8"-11 Thin Profile Nylok Nut
3008	1/4" ID X 3/4" OD Flat Washer	3264	5/16" Disc Spring HD
3009	5/16" - 18 UNC X 1-3/4" HH Bolt Gr 8	3265	#10-24 X 3/4" Truss Hd Phillips Screw
3012	3/8" - 16 UNC Hex Nut	3266	1/4" Int Tooth Lock Washer
3014	1/4"-20 UNC X 3/4" HH Bolt Gr 5	3267	5/16"-18 X 1-3/8" HH Bolt Gr 5
3019	5/16" Helical Lock Washer	3268	3/8"-24 X 1-1/4" HH Bolt Gr 8 x/Nylok
3020	5/16" STd Flat Washer	3269	5/16"-18 X 1" Soc HB
3023	1/4" Helical Lock Washer	3271	1"-14 Thin Prof Nylok Nut
3029	Front Grommet	3272	5/16" Int Tooth Lock Washer
3031	5/16"-18 UNC Acorn Nut	3273	8-18 X 3/8" Phil Pan HD
3033	1/2" SAE Flat Washer	3274	#6-32 X 1/2" Truss Hd Ph Screw
3048	3/8"-16 UNC X 1J" HH Bolt	3281	Clip
3052	3/32" Dia X 1" Cotter Pin	3297	1/2"-13 Thin Prof Nylok
3056	5/16" Fender Washer	3298	Washer .515 X .874 X .031
3057	3/8" Std Flat Washer	3300	Foam Pad
3061	5/16"-18 UNC X 3/8" Soc Set Screw	3301	Foam Pad 1/8" X 1" X 4"
3066	3/16" Std Flat Washer	3310	5/16"-18 Thin Prof Nyl
3072	1/8" X 1-3/4" Hair Pin Cotter	3318	3/8"-16 X 2-1/4" HH Bolt Gr 8
3074	5/16"-24 UNF Hex Jam Nut	3319	Idler Shock Mount
3081	#6-32 UNC Hex Nut	3321	5/16"-18 X 8" HHB Gr 8
3082	#6 Lock Washer	3322	5/16"-18 X 5-1/2" HHB Gr 8
3087	5/16"-18 UNC X 3/4" HH Bolt Gr 5	3323	5/16"-18 X 1-1/2" HHB Gr 8
3088	1/4"-20 X 1" HH Bolt Gr 5	3325	3/8"-16 X 3-1/2" HHB Gr 8
3091	1/2"-20 UNF Hex Lug Nut	3326	3/8"-16 X 4 HHB Gr 8
3093	5/16"-18 UNC X 1" HH Bolt Gr 5	3331	M6 X PI X 8MM HHB Gr 8.8
3101	7/16" Helical Lock Washer	3334	1/4"-20 Thin Prof Nyl
3106	1/4" X 1" Spirol Pin	3336	9/16" Int Tooth Lock Washer
3130	1/2" Contact Bellville Spring	3337	Retaining Ring
3133	#832 X 1/2" TR 3 Screw	3338	M8 X 1.25 P Tap Screw

3339	Snap Ring - 5/8"	3889	Drive Pulley 1.13 Bore
3343	Hub Bolt-Drilled	3890	Bearing
3344	Grease Zerk	3896	Hub Cover
3347	Washer-1.033 X 1.5 X .06	3897	Decal - DIXON
3348	5/16-18 X 3/4" Tap Screw	3898	Clutch Spacer - 503
3349	#806 Woodruff Key	4013	Wire Tie
3403	Bushing	4075	15 Amp Fuse
3511	Adhesive Bumper Pad	4146	Nylon Washer
3521	Engaging Cam Mount Bushing	4198	Blade Drive Clutch Switch
3531	Decal - OPERATING INSTRUCTIONS	4199	Light Switch
3536	Decal - DANGER	4201	Switch Key
3554	Fuel Cap/Gauge	4217	Battery
3585	Decal - CUTTING HEIGHT	4242	Deck Switch
3589	Spacer (Electric Clutch)	4256	Utility Box, Plastic
3590	Key 1/4" Sq X 1/2"	4274	Choke Control
3600	Rebound Mount	4276	Headlight Assembly
3601	Load Mount	4384	Relay
3602	Spacer Tube	4446	Wire Cover 36"
3603	ISO Mount Insert	4453	Access Cover Assembly
3617	Decal - DIXON	4467	Fuse Holder
3635	Tee-Fuel Line	4582	Battery Cable
3646	Fuel Line 20"	4585	Battery Ground Cable
3649	Fuel Line Clamp	4587	Wire Cover
3653	Floor Pad Left Front	4589	Covered Key
3654	Floor Pad Right Front	4594	Wire Cover 14"
3655	Floor Pad Left Rear	4605	Model Decal - 503
3656	Floor Pad Right Rear	4687	Battery Cover Assembly
3669	Decal - CAUTION	4701	Michigan Seat 50"
3675	Fuel Line Clamp	5070	3/16" Sq X .88 Key
3695	J-Bolt	5085	Brake Band
3702	Pulley	5087	Spacer 3/8" X 1/2"
3705	Velcro Strip - Hook	5101	Brake Link
3706	Velcro Strip - Latch	5170	Spring
3710	Handle Grip	5189	Bushing
3711	Hour Meter	5257	Brake Drum
3712	Handle Grip	5283	Link *
3713	Foam Tube	5500	T-Box
3715	End Cap	5501	Mount Plate
3717	3/8" Hose Clamp	5502	Mount Shim
3718	5/8" Hose Clamp	5503	T-Box Guide Left
3720	Tie Wrap	5504	T-Box Guide Right
3721	Decal - DANGER	5515	Idler Cable
3723	Decal - RESERVOIR	5522	Brake Link Right
3729	Handle Grip	5525	Brake Link Left
3731	Control Panel	5530	Control Pivot Shaft
3746	Decal - PARKING BRAKE	5531	Adjustable BUshing
3747	Deflector Spring	5537	Control Arm
3772	By-Pass Keeper	5540	Control Tube
3773	Left Rod End	5550	Hydrostat
3774	Right Rod End	5551	Hydrostat
3797	Fuel Tank - Plastic	5558	Hose Fitting
3813	Protective Cap	5560	Elbow - Male
3838	Muffler	5561	Adapter - Male (For 3/8" ID Hose)
3840	1/4" Hose - 21"	5562	Adapter - Male (For 5/8" ID Hose)
3844	Decal - HYDRO GEAR	5563	Tee
3847	Ignition Nut	5564	Filter Head
3848	Cap Nut	5565	Oil Filter
3852	Spring	5585	Tab
3876	Caster Spring	5595	Hose 5/8" X 14"
3878	Caster Plug	5602	Hose Guard Spring
3887	Chrome Lug Nut	5615	Connector/Elbow Assembly

5623	Electric Clutch	9191	Connecting Link
5624	Tank Cap	9192	Tie Bar
5625	Gearbox	9195	Tie Bar
5627	Left Fan	9196	Plate
5628	Right Fan	9212	Spring (Belt Tensioner)
5631	3/8" Hose - 21"	9219	Deck Hub
5632	3/8" Hose - 5"	9224	Outer Shaft
5633	5/8" Hose - 2"	9228	Deck Hub Bearing Spacer
5635	Reservoir Assembly	9242	Pulley Guard
5636	Brass Ferrule	9254	Lift Plate
6075	Engine Idler Spacer	9261	Deflector Tab
6100	Outer Shaft Key	9262	Rod 5/16" X 10
6101	Center Shaft Key	9264	Deflector Sub Assembly
6111	Deck Drive Belt	9265	Mower Blade Hi-Lift
6113	Blade Washer	9273	Mower Deck
6168	Trash Guard	9276	Idler Arm
6257	Blade Washer	9280	Engine Plate
6744	Spring	9298	Caster Tube Assembly
7034	Belt Keeper	9309	Caster Axle LH
8172	Frame - 503	9310	Caster Axle RH
8175	Upper Body Assembly - 503	9312	Bumper Weldment
8176	Lower Body Assembly - 503	9315	Caster Wheel & Tire
8177	Caster Tire - 50"		
8178	Caster Rim - 50"		
8179	Caster Bearing - 50"		
8180	Bearing Retainer 50"		
8328	Greasable Shaft 9225		
8573	Headlight Socket Assembly		
8576	Rear Wheel		
8577	Rear Tire		
9017	Seat Frame		
9023	Engine Mount - Fwd		
9024	Engine Mount - Rear		
9031	Lift Tube		
9035	Lift Frame		
9049	Lift Bushing Bracket		
9055	Lift Cam Left		
9056	Lift Cam Right		
9057	Front Lift Rod		
9065	Lift Handle		
9066	Lift Shaft		
9067	Control Rod		
9076	Seat Frame Cable		
9082	Seat Frame Pivot Rod		
9098	Hanger Rod		
9110	Tank Cover		
9142	Rear Lift Rod		
9156	Right Swivel Plate		
9157	Left Seivel Plate		
9158	Control Lever w/Grip Left		
9159	Control Lever w/Grip Right		
9164	Brake Plate		
9165	Brake Plate		
9168	Brake Shaft		
9171	Spacer 1.75		
9172	Spacer 1.50		
9174	Brake Rod		
9175	Spring Anchor		
9179	Brake Lever		