

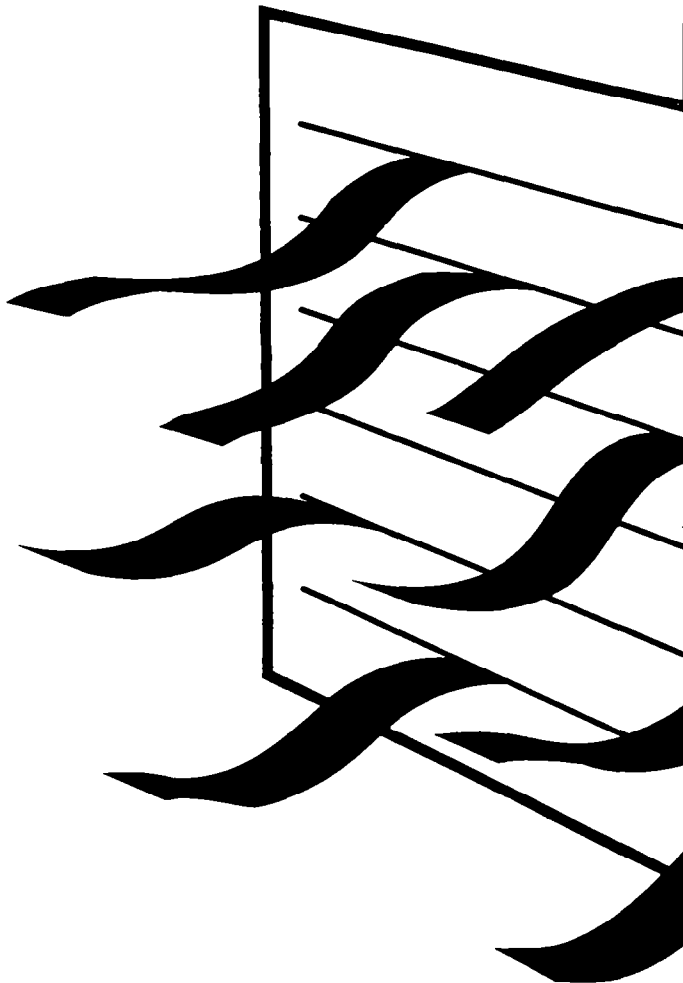

HOW TO MAKE A HOME BLIN.™

Installation, Use And Care

G U I D E



A Note To You	2
Air Conditioner Safety	3
Parts And Features	4
Electrical Requirements	5
Installing Your Air Conditioner	8
Operating Your Air Conditioner	13
Caring For Your Air Conditioner	15
Troubleshooting	19
Requesting Assistance Or Service	20
Warranty	24

1-800-253-1301

Call Our Consumer Assistance
Center with questions or comments.

SLIDER/CASEMENT WINDOW AIR CONDITIONERS

PART NO. 23-11-1187N-001/789601

MODELS ACS072XE ACS102XE

A Note to You

Thank you for buying a WHIRLPOOL® appliance.

Because your life is getting busier and more complicated, WHIRLPOOL Air Conditioners are easy to use, save time, and help you manage your home better. To ensure you enjoy years of trouble-free operation, we developed this Use and Care Guide. It contains valuable information about how to operate and maintain your appliance properly and safely. Please read it carefully. Also, please complete and mail the Ownership Registration Card provided with your appliance. This card helps us notify you about any new information on your appliance.

Please record your model's information.

Whenever you call to request service on your appliance, you need to know your complete model number and serial number. You can find this information on the model and serial number label (see diagram on page 4 for location of label).

Please also record the purchase date of your appliance and your dealer's name, address, and telephone number.

Model Number _____

Serial Number _____

Purchase Date _____

Dealer Name _____

Dealer Address _____

Dealer Phone _____

Keep this book and the sales slip together in a safe place for future reference.

**Our Consumer Assistance Center
number is toll-free 24 hours a day.**

1-800-253-1301

Air Conditioner Safety

Your safety is important to us.

This guide contains statements under warning symbols. Please pay special attention to these symbols and follow any instructions given. Here is a brief explanation of the use of the warning symbol.

WARNING

This symbol alerts you to such dangers as fire, electrical shock, burns, and personal injury.

IMPORTANT SAFETY INSTRUCTIONS

WARNING

To reduce the risk of fire, electrical shock, or injury when using your air conditioner, follow these basic precautions:

- Read all instructions before using the air conditioner.
- Complete the installation requirements as described in the Installation Instructions.
- Do not operate the air conditioner with the front panel removed.
- Never clean air conditioner parts with flammable fluids. The fumes can create an explosion or fire hazard.

• FOR YOUR SAFETY •

DO NOT STORE OR USE GASOLINE OR OTHER FLAMMABLE VAPORS AND LIQUIDS IN THE VICINITY OF THIS OR ANY OTHER APPLIANCE. THE FUMES CAN CREATE A FIRE HAZARD OR EXPLOSION.

– SAVE THESE INSTRUCTIONS –

Help us help you

Please:

- Install your air conditioner in a window that will hold the weight, and secure the air conditioner according to the Installation Instructions.
 - Connect the air conditioner to the proper kind of outlet with the correct electrical supply and grounding. (See the Installation Instructions.)
 - Make sure the air conditioner is the correct size for the area you want to cool.
 - Use the air conditioner only to do what a window air conditioner is designed to do.
 - Make sure the air conditioner is not used by anyone unable to operate it properly.
 - Maintain the air conditioner properly.
- Also, remove the Energy Label. Use a damp cloth to take off any glue residue. DO NOT use sharp instruments, flammable fluids, or abrasive cleaners. These can damage the material.

Parts And Features

This section contains captioned illustrations of your appliance. Use them to become familiar with where all parts and features are located and what they look like. To help you find information on specific parts or features quickly, page references are included.

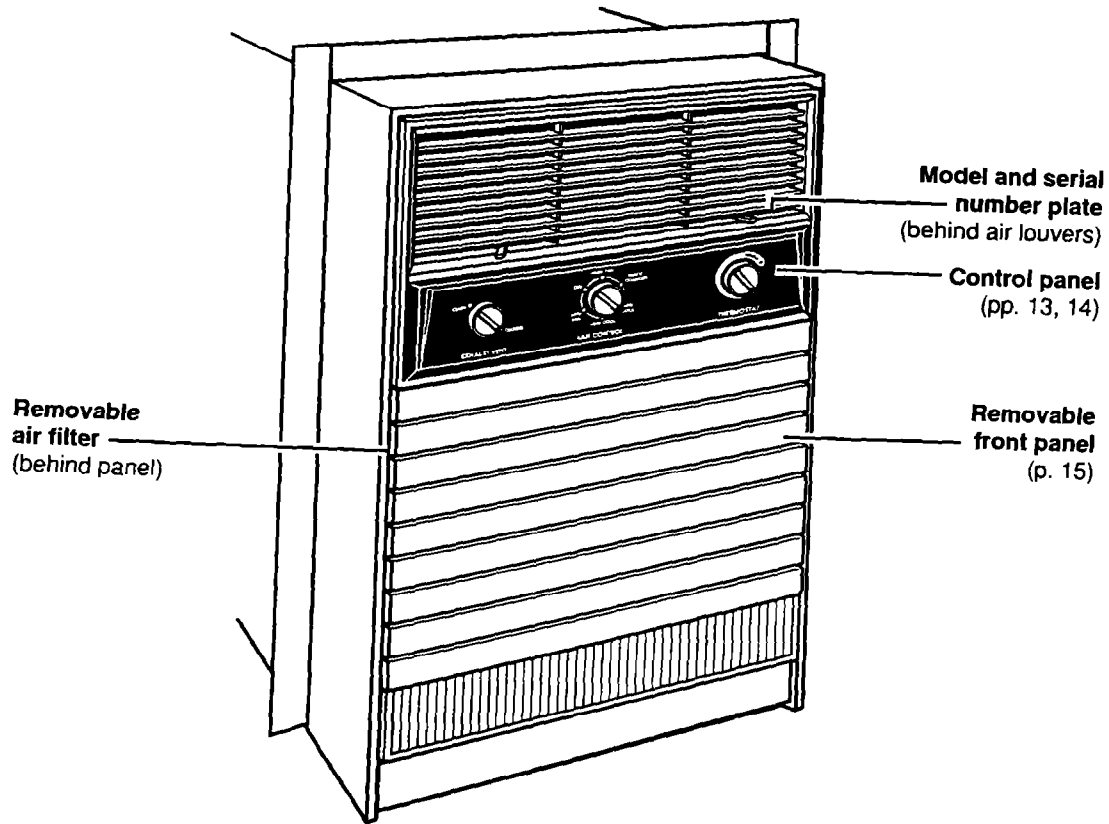

Control Panel

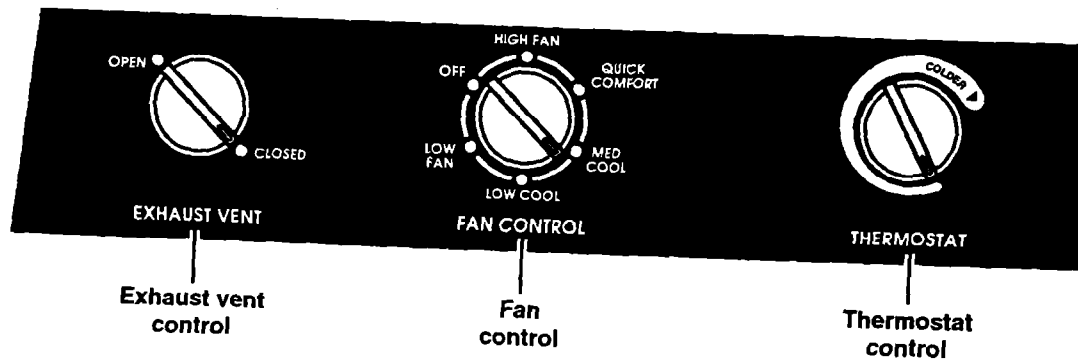

Electrical Requirements

Below are electrical plug variations; choose the one which matches the ampere rating of your unit. Your model's ampere rating is printed on the model and serial number label, attached to the unit, behind the front panel. (See diagram on page 4.)

Observe all local codes and ordinances.

Do not, under any circumstances, remove the power supply cord grounding prong.

NOTE: If codes permit and a separate grounding wire is used, it is recommended that a qualified electrician determine that the grounding path is adequate and not interrupted by plastic, non-metallic gaskets or other insulating materials.

Check with a qualified electrician if you are in doubt as to whether the air conditioner is properly grounded.

⚠ WARNING

Fire Hazard Do not use an extension cord. Doing so can cause death, fire, or electrical shock.

⚠ WARNING

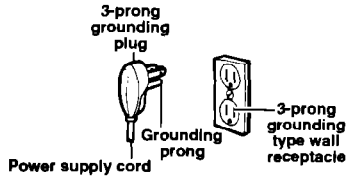
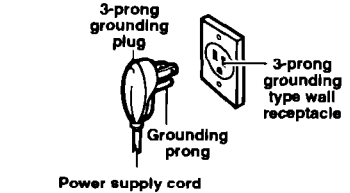
Electrical Shock Hazard Plug appliance into a grounded outlet. Do not remove ground prong. Do not ground to a pipe. Do not fuse neutral or ground. Failure to follow these instructions can result in death or electrical shock.

ELECTRICAL REQUIREMENTS

PLUG TYPE	ELECTRICAL REQUIREMENTS	SEE PAGE
	115 volt models with amperes up through 7.5	6
	For 115 volt models with amperes from 7.6 to 12.0	7

115 volt models with amperes up through 7.5

Receptacle wiring

Receptacle wiring should be a minimum of 14 gauge. Use copper wire only. It is the responsibility of the consumer to provide proper and adequate receptacle wiring, installed by a qualified electrician. Observe National Electrical Code and all local governing codes and ordinances.

Electrical connection

Electrical ground is required on this air conditioner.

Recommended grounding method

For your personal safety, this air conditioner must be grounded. This air conditioner is equipped with a power supply cord having a 3-prong grounding plug. To minimize possible shock hazard, the cord must be plugged into a mating 3-prong grounding-type wall receptacle, grounded in accordance with the National Electrical Code (ANSI/NFPA 70 – latest edition) and local codes and ordinances. If a mating wall receptacle is not available, it is the responsibility of the customer to have a properly grounded 3-prong wall receptacle installed by a qualified electrician.

Electrical requirements

A 115 volt (103.5 min., 126.5 max.), 60 Hz, AC only, 15 ampere fused electrical supply is required (time delay fuse or time delay circuit breaker required). It is **required** that a separate circuit, serving only this air conditioner, be provided.

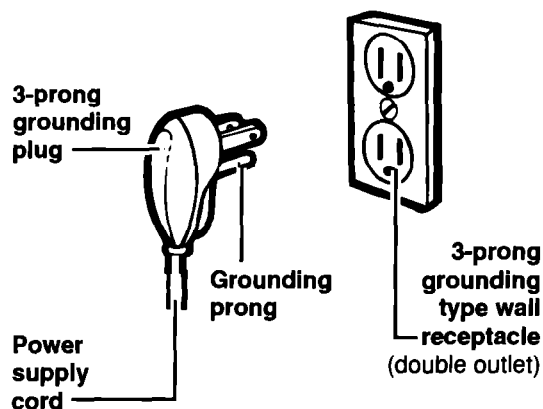

115 volt models with amperes from 7.6 through 12.0

Receptacle wiring

Receptacle wiring should be a minimum of 14 gauge. Use copper wire only. It is the responsibility of the consumer to provide proper and adequate receptacle wiring, installed by a qualified electrician. Observe National Electrical Code and all local governing codes and ordinances.

Electrical connection

Electrical ground is required on this air conditioner.

Recommended grounding method

For your personal safety, this air conditioner must be grounded. This air conditioner is equipped with a power supply cord having a 3-prong grounding plug. To minimize possible shock hazard, the cord must be plugged into a mating 3-prong grounding-type wall receptacle, grounded in accordance with the National Electrical Code (ANSI/NFPA 70 – latest edition) and local codes and ordinances. If a mating wall receptacle is not available, it is the responsibility of the customer to have a properly grounded 3-prong wall receptacle installed by a qualified electrician.

Electrical requirements

A 115 volt (103.5 min., 126.5 max.), 60 Hz, AC only, 15 ampere fused electrical supply is required (time delay fuse or time delay circuit breaker required). It is **required** that a separate circuit, serving only this air conditioner, be provided.

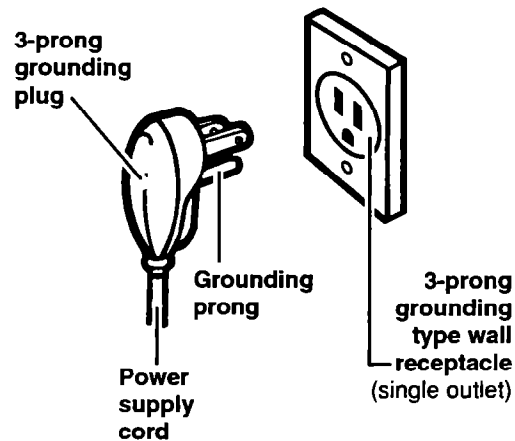

Installing Your Air Conditioner

Preparing for installation

Tools required

- Flat-head screwdriver
- Carpenter's level
- Tape measure
- Electric or hand drill
- 1/8-inch drill bit
- Pencil
- Awl
- Knife

⚠ WARNING

Excessive Weight Hazard
Use 2 or more people to move and install air conditioner.
Failure to do so can result in back or other injury.

Installation tips

1. Choose a proper size window.

- 15½ inches minimum width
- 22 inches minimum height
- 36 inches maximum height

NOTE: The height measurement must be of an unobstructed opening above the mounting platform. In some cases, due to a variety of stop and track arrangements, the above dimensions may vary slightly.

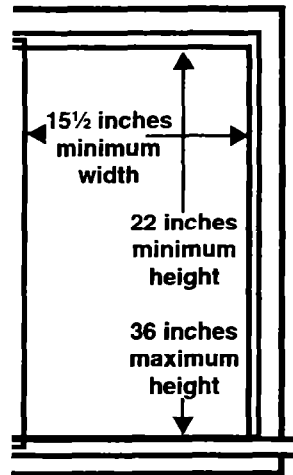

2. Choose the proper window location.

Choose a window that will allow the cooled air to flow freely and directly into the room(s) you want to cool. Remember, it is difficult to move air around corners. Also, choose a window that is within 6 feet of an electrical outlet. (See "Electrical requirements" on pages 5-7 for receptacle and wiring needs.) **Do not use an extension cord.**

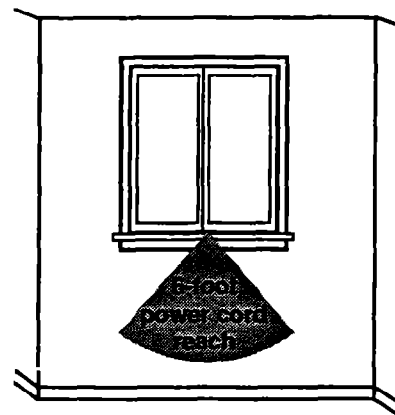

Installing in a sliding window

NOTE: This air conditioner must be installed according to all applicable codes and ordinances.

1. Choose the installation site. The window frame and side of the structure must be able to support at least 110 lbs. of weight.
2. Remove one sliding sash from the window frame.
3. Loosely attach the support angle to the bottom of the support platform using two $\frac{7}{16}$ " long machine screws, flat washers, and nuts.

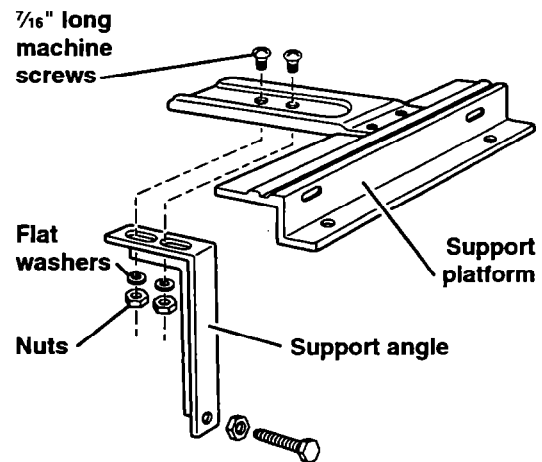

4. Place the support platform against the lower window track and firmly against the vertical edge of the window frame.
5. Attach the support platform to the window stool using two self-tapping screws. Tighten screws securely.

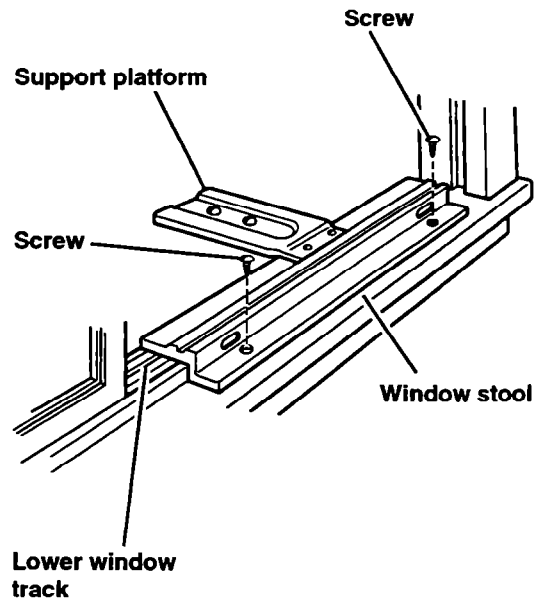

continued on next page

INSTALLING YOUR AIR CONDITIONER

6. Pull the support angle against the outside of the structure. Tighten two $\frac{7}{16}$ " long machine screws on top of the support platform.

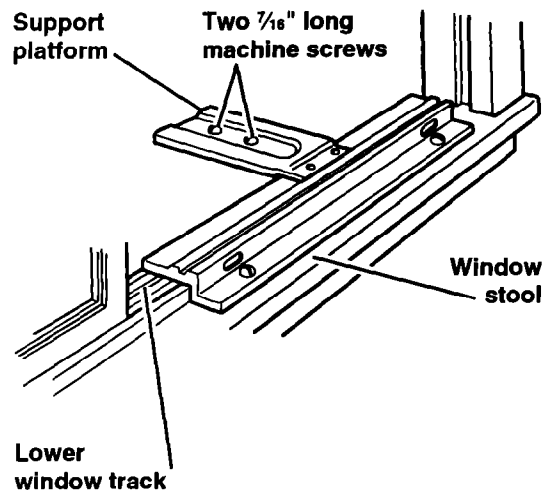

7. Adjust the leveling bolt to position the support angle in a level plane. This will allow for proper angle. Tighten the leveling bolt locknut. The air conditioner must be tilted back slightly to facilitate proper condensate disposal.

NOTES: Be sure the window track is securely attached to the building construction. Use longer screws into the subframing if necessary.

Do not drill a hole in the bottom pan. The air conditioner is designed to operate with approximately $\frac{1}{2}$ " of water in the bottom pan.

8. Cut two pieces of adhesive back foam seal equal to the height of the window opening. Remove backing and apply to the vertical inside edges of the window frame and sliding sash that will rest against the air conditioner.
9. Replace the sliding sash in the window frame.

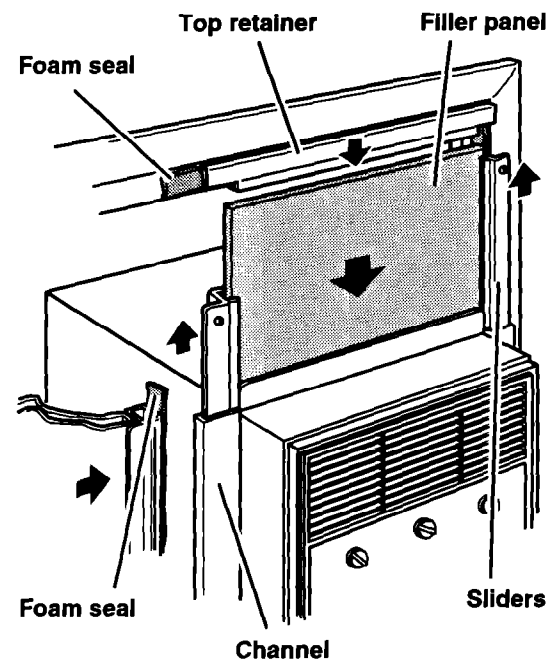
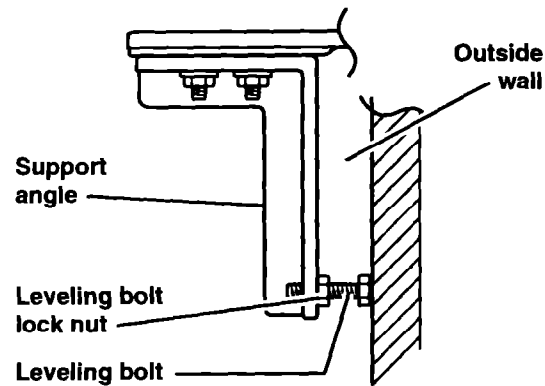

INSTALLING YOUR AIR CONDITIONER

- Slide the air conditioner onto the support platform. Be sure the unit side channel butts against the vertical edge of the window frame. Watch out for the sharp metal fins on the front and rear coils.

NOTE: If unit side channel does not fit securely, remove air conditioner and readjust leveling bolt.

- Using the existing clearance holes in the air conditioner's bottom bar as guides, drill two $\frac{1}{8}$ " holes through the window channel frame. Install two self-threading screws through the clearance holes and into these holes. Tighten the screws securely. The air conditioner should be firmly anchored to the window channel frame. Be sure your air conditioner does not fall out during installation.
- Slide the inside window sash closed. Make sure the vertical edge of the inside window sash is pressed firmly against the side of the unit cabinet. Cut remaining adhesive back foam seal equal to the width of the window opening. Remove the backing and apply to the top inside edge of the window frame.
- Install the speed clips on the top and bottom inside edges of the window to provide locking.
- Insert the appropriate plastic foam seal between the inside window sash and the outside window.
- Place the top retainer on the top edge of the filler panel. Then place the bottom edge of the filler panel into the groove of the bottom retainer which is mounted on the air conditioner. The filler panel may be trimmed with a knife or scissors to fit the window height.
- Slide the sliders upward making sure the filler panel aligns in the sliders.
- With the sliders up against the top retainer, drill $\frac{1}{8}$ " hole through the window frame using the existing clearance hole in the slider as a guide. Install the self-threading screw in the hole and tighten securely. Repeat for the other slider.
- Check all seals and plug all air leaks around the air conditioner with a suitable weather-proof sealing compound.

⚠ WARNING

Excessive Weight Hazard

Use 2 or more people to move and install air conditioner.

Failure to do so can result in back or other injury.

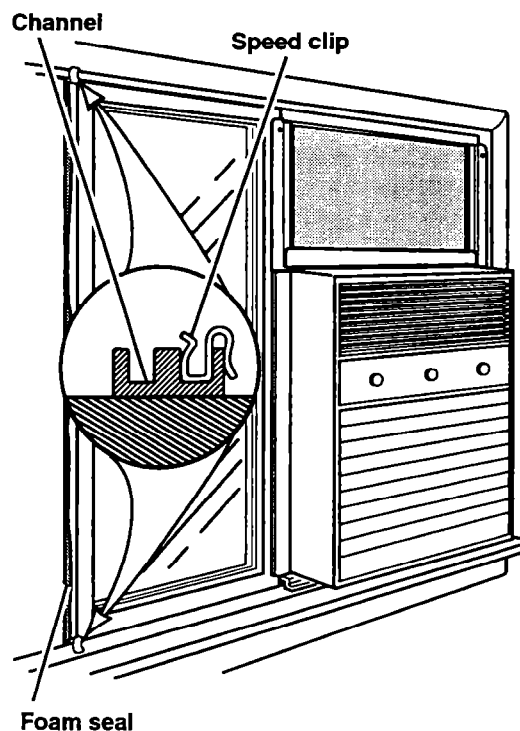
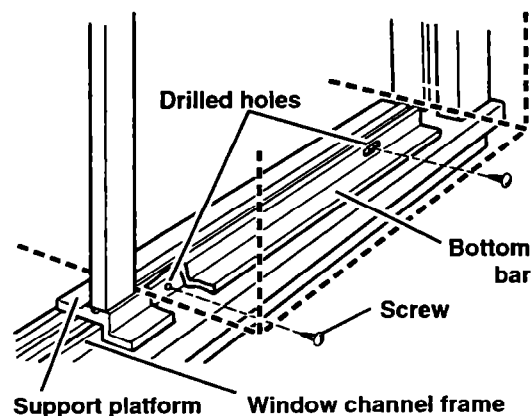

Installing in a casement window

Since styles and sizes of casement windows vary widely, it is advisable to have the air conditioner installed by someone skilled in this type of installation. Your appliance dealer can recommend or supply qualified people to install your air conditioner.

1. Closed or stationary windows: Install unit in stationary sash to avoid crank handles or window latches. If unit is to be installed in or next to a movable sash, it may be necessary to remove catch, handle, or both. Remove crank handle and secure window in closed position. Remove glass panes and horizontal mountings to a height sufficient to mount unit.

2. Open window frame: Remove crank mechanism and catch handles. Fold the window sash back against the exterior wall of the building and secure, or remove completely where possible.

Do not block air circulation to the outside louvers.

3. A filler panel will be required at the side of the air conditioner when installed in windows having width greater than 15½".

Filler panel should be made from ¾" thick wood securely anchored to one side of the opening so that a 15½" wide opening is provided. The filler panel should run the full length of the window. Paint to suit.

4. Install the air conditioner in the same manner as described for sliding windows. (See "Installing in a sliding window" on page 9.)

Installing in a wood sliding or wood casement window

1. For a wood casement window, it is necessary to construct a frame, using at least 1" thick wood with a 15½" wide opening.

2. Paint the frame and fasten it securely, sealing it into the window opening.

3. Install the air conditioner into the frame following procedures for metal sliding and casement windows. (See "Installing in a sliding window" on page 9.)

Operating Your Air Conditioner

In order to obtain the best possible results from your air conditioner, it is important that you operate it properly. This section will tell you how to do just that.

Starting your air conditioner

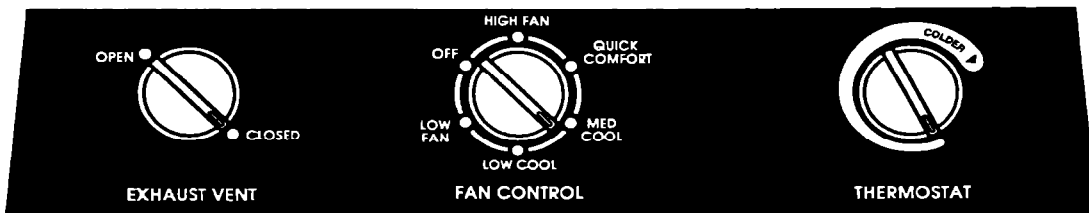

1. Set Exhaust Vent Control to CLOSED for maximum cooling performance.
2. Set Fan Control to the desired setting.
 - HIGH FAN** for maximum room air circulation when no cooling is desired
 - QUICK COMFORT** for fastest cooling
 - MED COOL** for normal cooling
 - LOW COOL** for minimum cooling
 - LOW FAN** for minimum room air circulation when no cooling is desired
3. Turn the Thermostat Control to the desired setting. You can adjust the air conditioner's cooling performance by turning the Thermostat Control clockwise for more cooling or counterclockwise for less cooling. You will need to experiment to find the setting which suits you best.
4. To turn the air conditioner off, or in the event of a power interruption, turn Fan Control to OFF.

NOTE: If you turn your air conditioner off or if the compressor turns off when lowering the Thermostat Control, wait at least three minutes before turning it back on. Doing this keeps the air conditioner from blowing a fuse or tripping a circuit breaker.

⚠ WARNING



Fire Hazard

Do not use an extension cord.
Doing so can result in death, fire, or electrical shock.

⚠ WARNING



Electrical Shock Hazard

Plug into a grounded 3-prong outlet.
Do not remove ground prong.
Failure to follow these instructions can result in death or electrical shock.

Using the exhaust vent control

The Exhaust Vent Control draws stale or smoky air from the room or circulates existing room air.

To exhaust room air:

1. Set Exhaust Vent Control to OPEN.
2. Set Fan Control to desired setting. If no cooling is desired, set Fan Control to High Fan or Low Fan.
3. Set Thermostat Control to desired setting.

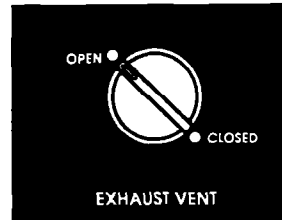

To circulate room air:

1. Set Exhaust Vent Control to CLOSED.
2. Set Fan Control to desired setting. If no cooling is desired, set Fan Control to High Fan or Low Fan.
3. Set Thermostat Control to desired setting.

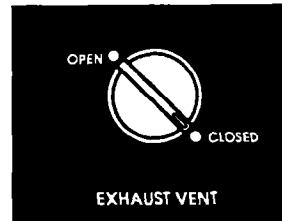

NOTE: For maximum performance, the Exhaust Vent Control must be in the CLOSED position when cooling or room air circulation is desired.

Changing air direction

The louvers, in the top grille area of the air conditioner, control the direction of the cooled air. Move the levers in the direction you want the air to go (right or left).

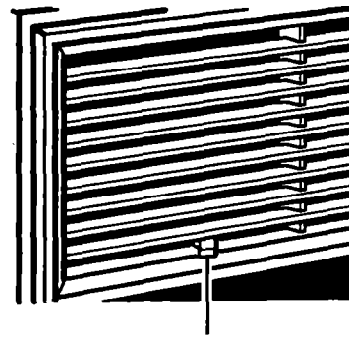

Lever for left/right airflow

Caring For Your Air Conditioner

Proper maintenance of your air conditioner will help ensure longer life and lower operating costs. This section will tell you how to clean your air conditioner and perform annual maintenance. You can always call your authorized Whirlpool servicing dealer for an annual checkup.

Cleaning the front panel

! WARNING



Explosion Hazard

Unplug power cord from outlet before cleaning air conditioner.

Use only nonflammable cleaners.

Failure to follow these instructions can result in death, explosion, fire, or electrical shock.

1. Unplug the power cord.
2. Grasp both sides of the front panel and pull forward. The front panel will pivot forward to reveal the air filter.
3. Remove the air filter from the tabs and clean it separately. (See "Cleaning the air filter" on page 16.)
4. Clean front panel with warm water, mild soap or detergent, and a soft cloth. Rinse and dry thoroughly.
5. Wipe control panel clean with a soft, dry cloth.
6. Replace air filter.
7. Replace the front panel.
8. Plug in the power cord.

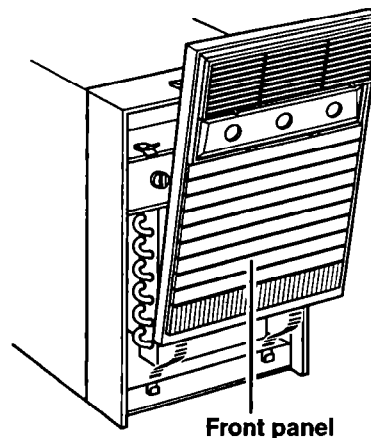

Cleaning the air filter

The filter may be cleaned. A clean filter helps remove dust, lint, and other particles from the air. Check every two weeks to see if filter needs cleaning.

1. Turn Fan Control to OFF.
2. Grasp both sides of the inlet grille and pull forward. The front panel will pivot forward to reveal the air filter.
3. Remove the air filter from the tabs.
4. Carefully wash the air filter with a mild detergent and warm water. Rinse with clear water, squeeze dry, and replace.
5. Replace the front panel.
6. Return Fan Control to the desired setting.

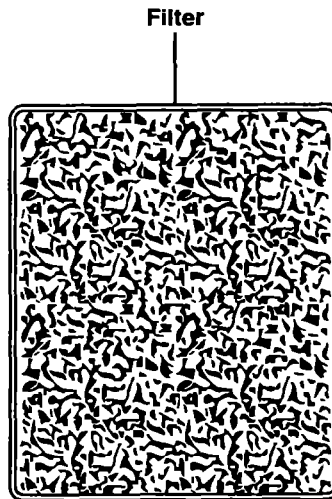

Annual maintenance

Your air conditioner needs annual maintenance to help ensure steady, top performance throughout the year.

Call the service company recommended by your dealer to:

- Inspect and clean the coils and condensate water passages.
- Check fan and fan motor.

The compressor is sealed and needs no oiling. The expense of an annual inspection is the customer's responsibility.

OR

If you are familiar with electrical appliances, you can do the cleaning and maintenance yourself. If you choose to do so, follow these steps:

1. Unplug power cord.
2. Remove the air conditioner from the window channel frame and off of the support platform.
3. Remove the front panel. (See page 15.)
4. Remove the screws from the top and sides of the cabinet, and then remove the cabinet.
5. Wrap the motor, electrical control box, and compressor terminal box in plastic film to make sure no water or other liquid gets inside. Water or other liquids could damage the insulation and cause serious mechanical problems.
6. Clean and hose out the base, coils, and condensate pan. Clean at least once a year, or more often if the condenser coils and pan collect dirt, sand, leaves, insects, or algae. Also, clean if you detect an odor coming from the air conditioner. Do not use the water collected in the air conditioner for drinking purposes. It is not sanitary.
7. Remove the plastic film from the motor and electrical parts.
8. Reattach the cabinet with the screws. Replace the front panel, and reinstall the air conditioner.
9. Reconnect power supply.

⚠ WARNING



Electrical Shock Hazard

Unplug power cord from outlet before servicing.

Be sure no liquid gets into the motor, electrical control box, or compressor terminals.

Failure to follow these instructions can result in death, electrical shock, or serious injury.

⚠ WARNING

Excessive Weight Hazard

Use 2 or more people to move and install air conditioner.

Failure to do so can result in back or other injury.

NOTE: It is a good idea to wait 24 hours before starting the air conditioner again. This allows time for all areas to dry out. The water from rainfall or from normal operation does not harm these components.

Understanding normal operating sounds

When your air conditioner is **operating normally**, you will hear sounds such as:

- Droplets of water hitting the condenser, causing a “pinging” or “clicking” sound. Water droplets help to cool the condenser.
- Air movement from the fan, especially on high fan speed settings.
- Clicks from the thermostat cycle.

Sounds also may be caused by house construction – such as vibration of the unit due to wall construction or unsteady window mounting area.

Saving energy

You can help save energy by following the tips below.

- Improve your home’s insulation. Seal all doors and windows. Close the fireplace flue.
- Close all blinds and drapes on sunny sides of the house. Add window awnings.
- Keep the air filter clean.
- Do not block the airflow with drapes or furniture.
- Ventilate the attic. High temperatures in the attic add to the air conditioner’s cooling load.
- Try not to use heat-producing appliances during the hottest part of the day.
- Turn off lights and appliances when they are not needed.
- Keep heat registers and cool-air returns closed.
- Use exhaust venting fans when cooking, doing laundry, or bathing.

Troubleshooting

Listed in the chart below are the most common problems consumers run into with their air conditioners. Please read through this chart before calling for service. It could save you the cost of a service call.

PROBLEM	CHECK THE FOLLOWING
Air conditioner won't run	Is the air conditioner plugged into a live circuit with proper voltage? Has the time-delay fuse blown or circuit breaker tripped? Is the Fan Control set to OFF? Is the Thermostat Control set correctly? Has the local power failed?
Air conditioner blows fuses or trips circuit breaker	Are time-delay fuses being used? Is an extension cord being used? Do not use an extension cord with this or any other appliance. Are you waiting three minutes before trying to restart the air conditioner?
Air conditioner turns on and off OR does not cool the room	Is the air filter clean? Are the inside evaporator coils and the outside condenser coils clean? Is there excessive moisture or heat in the room (open container cooking, showers, etc.)? Is the Fan Control set too low? Is the Thermostat Control set too low?

Requesting Assistance or Service

Before calling for assistance or service, please check "Troubleshooting" on page 19. It may save you the cost of a service call. If you still need help, follow the instructions below.

1. If you need assistance* ...

Call the Whirlpool Consumer Assistance Center telephone number.



Dial toll-free from anywhere in the U.S.A.:

1-800-253-1301

and talk with one of our trained consultants. The consultant can instruct you in how to obtain satisfactory operation from your appliance or, if service is necessary, recommend a qualified service company in your area.

If you prefer, write to:

Mr. William Clark
Consumer Assistance Representative
Whirlpool Corporation
2000 North M-63
Benton Harbor, MI 49022-2692

Please include a daytime phone number in your correspondence.

2. If you need service* ...

Whirlpool has a nationwide network of authorized Whirlpool service companies. Whirlpool service technicians are trained to fulfill the product warranty and provide after-warranty service, anywhere in the United States. To locate the authorized Whirlpool service company in your area, call our Consumer Assistance Center telephone number (see Step 1) or look in your telephone directory Yellow Pages under:

• APPLIANCE-HOUSEHOLD-
MAJOR, SERVICE & REPAIR

- See: Whirlpool Appliances or
Authorized Whirlpool Service
(Example: XYZ Service Co.)

• WASHING MACHINES &
DRYERS, SERVICE & REPAIR

- See: Whirlpool Appliances or
Authorized Whirlpool Service
(Example: XYZ Service Co.)



3. If you need FSP® replacement parts ...

FSP is a registered trademark of Whirlpool Corporation for quality parts. Look for this symbol of quality whenever you need a replacement part for your WHIRLPOOL® appliance. FSP replacement parts will fit right and work right, because they are made to the same exacting specifications used to build every new WHIRLPOOL appliance.

To locate FSP replacement parts in your area, refer to Step 2 or call the Whirlpool Consumer Assistance Center number in Step 1.

4. If you are not satisfied with how the problem was solved ...

- Contact the Major Appliance Consumer Action Program (MACAP). MACAP is a group of independent consumer experts that voices consumer views at the highest levels of the major appliance industry.
- Contact MACAP only when the dealer, authorized servicer, and Whirlpool have failed to resolve your problem.

Major Appliance Consumer Action Program
20 North Wacker Drive
Chicago, IL 60606

- MACAP will in turn inform us of your action.

* When asking for help or service:

Please provide a detailed description of the problem, your appliance's complete model and serial numbers, and the purchase date. (See page 2.) This information will help us respond properly to your request.

Index

This index is alphabetical. Look for the word or phrase you are interested in, then look for the page number.

TOPIC	PAGE
AIRFLOW	
Directing	14
CLEANING	
Air filter	16
Front panel	15
ELECTRICAL REQUIREMENTS	5, 6, 7
ENERGY	
Saving	18
FEATURES/PARTS	4
INSTALLATION	
Sliding window	9, 10, 11
Casement window	12
Wood sliding/wood casement window ...	12
MAINTENANCE	
Annual, performing	17
OPERATING AIR CONDITIONER	13, 14
PARTS/FEATURES	4
SAFETY	3
SERVICE	
Parts	20
Requesting	20
TROUBLESHOOTING	19
WARRANTY	24

WHIRLPOOL®

Room Air Conditioner Warranty

LENGTH OF WARRANTY	WHIRLPOOL WILL PAY FOR						
FULL ONE-YEAR WARRANTY From Date of Purchase	FSP® replacement parts and repair labor to correct defects in materials or workmanship.						
FULL FIVE-YEAR WARRANTY From Date of Purchase	FSP replacement parts and repair labor to correct defects in materials or workmanship in the sealed refrigeration system. These parts are: <table style="margin-left: 40px; border: none;"> <tr> <td style="padding-right: 20px;">1. Compressor</td> <td>4. Drier-strainer</td> </tr> <tr> <td>2. Evaporator</td> <td>5. Connecting tubing</td> </tr> <tr> <td>3. Condenser</td> <td></td> </tr> </table>	1. Compressor	4. Drier-strainer	2. Evaporator	5. Connecting tubing	3. Condenser	
1. Compressor	4. Drier-strainer						
2. Evaporator	5. Connecting tubing						
3. Condenser							
WHIRLPOOL WILL NOT PAY FOR							
<p>A. Service calls to:</p> <ol style="list-style-type: none"> 1. Correct the installation of your air conditioner. 2. Instruct you how to use your air conditioner. 3. Replace house fuses or correct house wiring. 4. Clean or replace air filter. <p>B. Pickup and delivery. Your air conditioner is designed to be repaired in the home.</p> <p>C. Damage to your air conditioner caused by accident, misuse, fire, flood, acts of God, or use of products not approved by Whirlpool.</p> <p>D. The removal and reinstallation of your air conditioner if it is installed in an overhead or other inaccessible location or not installed in accordance with published installation instructions.</p> <p>E. Repairs to parts or systems caused by unauthorized modifications made to the appliance.</p>							

6/94

Service under the full warranties must be provided by an authorized Whirlpool service company.

WHIRLPOOL CORPORATION SHALL NOT BE LIABLE FOR INCIDENTAL OR CONSEQUENTIAL DAMAGES. Some states do not allow the exclusion or limitation of incidental or consequential damages so this exclusion or limitation may not apply to you. This warranty gives you specific legal rights, and you may also have other rights which vary from state to state.

Outside the United States, a different warranty may apply. For details, please contact your authorized Whirlpool dealer.

If you need service, first see the "Troubleshooting" section of this book. After checking "Troubleshooting," additional help can be found by checking the "Requesting Assistance or Service" section, or by calling our Consumer Assistance Center telephone number, **1-800-253-1301**, from anywhere in the U.S.A.