

Viking Use/Installation Guide



Viking Range Corporation
111 Front Street
Greenwood, Mississippi 38930 USA
(662) 455-1200

For product information,
call 1-888-VIKING1 (845-4641)
or visit the Viking Web site at
vikingrange.com

AjMadison
Your Appliance Authority™
800-570-3355

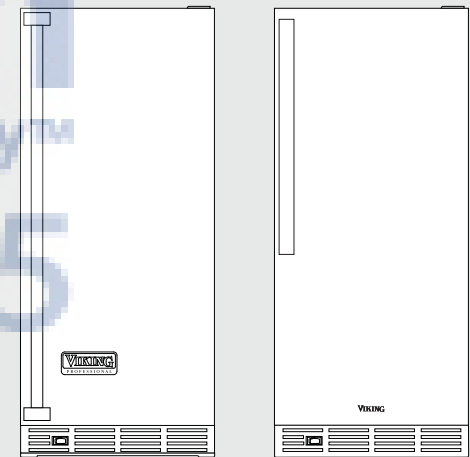

15"W. Undercounter/
Freestanding Ice Machine



(010509J)

IMPORTANT - PLEASE READ AND FOLLOW

- Before beginning, please read these instructions completely and carefully.
- Do not remove permanently affixed labels, warnings, or plates from the product. This may void the warranty.
- Please observe all local and national codes and ordinances.
- Please ensure that this product is properly grounded.
- The installer should leave these instructions with the consumer who should retain for local inspector's use and for future reference.

⚠ WARNING

To reduce the risk of fire, electric shock, or injury when using your unit, follow these basic precautions:

- Read all instructions before using the unit.
- Never allow children to operate, play with, or crawl inside the unit.
- Never clean unit parts with flammable fluids. The fumes can create a fire hazard or explosion.
- Always turn the power on/off switch (located behind the air grille on top right side) to the OFF position before attempting to change light bulbs, clean, or service the unit.

FOR YOUR SAFETY

DO NOT STORE OR USE GASOLINE OR OTHER FLAMMABLE VAPORS AND LIQUIDS IN THE VICINITY OF THIS OR ANY OTHER APPLIANCE. THE FUMES CAN CREATE A FIRE HAZARD OR EXPLOSION.

It is your responsibility to be sure your ice machine is:

- located so the front is not blocked to restrict incoming or discharge air flow.
- properly leveled.
- located in a well ventilated area.
- connected to the proper kind of outlet, with the correct electric supply and grounding. A 115V, 60 Hz, 15 amp fused electrical supply is required. **NOTE:** Time delay fuse or circuit breaker is recommended.
- not used by anyone unable to operate it properly.
- used only for its intended purpose.
- properly maintained.

•SAVE THESE INSTRUCTIONS•

PROPER DISPOSAL (OF OLD REFRIGERATION UNIT)

⚠ DANGER

RISK OF CHILD ENTRAPMENT

Before You Throw Away Your Old Refrigeration Unit:

- Take off the doors.
- Leave the shelves in place so that children may not easily climb inside.

IMPORTANT: Child entrapment and suffocation are not problems of the past. Junked or abandoned refrigeration units are still dangerous... even if they will sit for "just a few days."

IMPORTANT:

Now that you have a new ice machine, it is extremely important that you dispose of your old appliance in a way that minimizes the possibility that children will find it. There have been many cases in years past of children crawling inside junked and abandoned refrigeration units and becoming trapped or suffocated.

Contact your municipal waste disposal authority to find out the best and safest way to dispose of your old refrigeration unit.

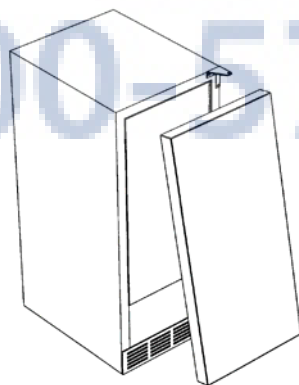

GENERAL INFORMATION

Unpack

1. Remove banding from bottom of carton. Lift carton up and off of the ice machine
2. Remove all tape and packaging material from the outside and inside of the cabinet.
3. Keep all carton packaging until your ice machine has been thoroughly inspected and found to be in good condition.

Area Requirements

1. Place unit so the front side will be completely unobstructed to provide proper air flow. The unit may be closed in on the top and three sides, but the front **MUST BE** unobstructed for air circulation and proper operation. Installation should be such that the cabinet can be moved for servicing if necessary.
2. Unit should be in a well ventilated area. Best results are obtained at temperatures between 55°F (13°C) and 80°F (27°C) for built-in indoor models, between 55°F (13°C) and 90°F (32°C) for indoor freestanding models, and between 45°F (7.2°C) and 110°F (43°C) for outdoor models.
3. Provisions for electricity should be determined before placing unit in proper place.
4. For best performance, outdoor units should be installed away from direct sunlight or under a counter or sink.

UNDERCOUNTER CABINET CUTOUT

15" W. Models

A	15" (38.1 cm)*
B	Min. 34 1/2" (87.6 cm) Max. 35 1/8" (89.2 cm)
C	24" (61.0 cm)

*15" (38.1 cm) width for cabinet only. If door is recessed between cabinets, cabinet cutout must be 15-1/4" (38.7 cm).

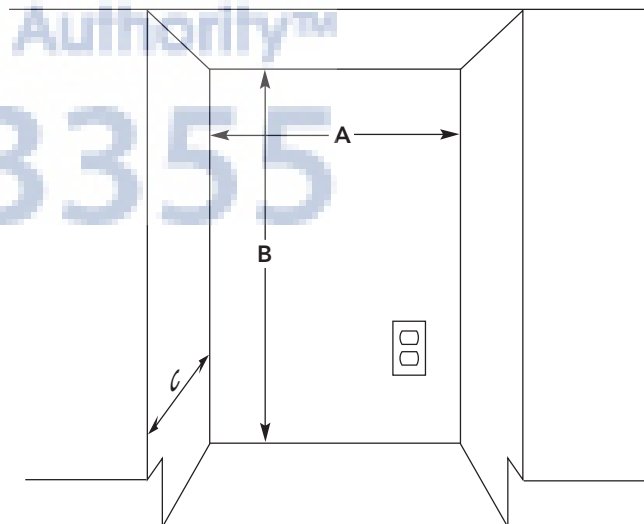

SPECIFICATIONS/DIMENSIONS

PROFESSIONAL MODELS

Basic Electric Data

- 115 VAC/60 Hz
- Maximum amps - 3.0
- Approximate Shipping Weight - 100 lbs. (45.0 kg)

Dimensions

VUIM

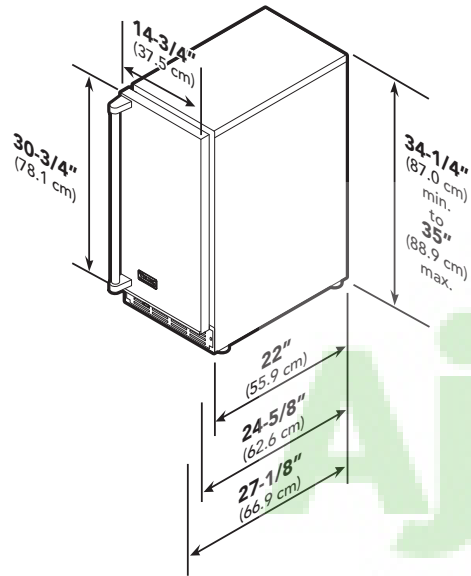

Door Swing

VUIM

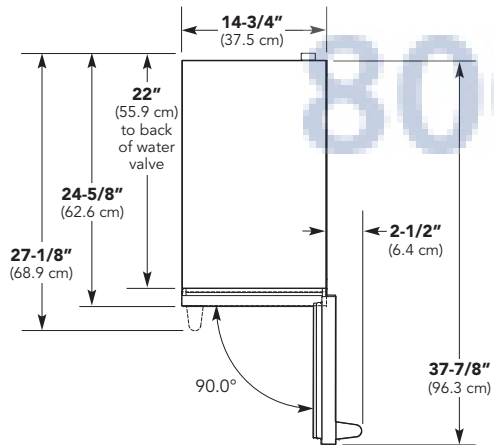

SPECIFICATIONS/DIMENSIONS

DESIGNER MODEL

Basic Electric Data

- 115 VAC/60 Hz
- Maximum amps - 3.0
- Approximate Shipping Weight - 100 lbs. (45.0 kg)

Dimensions

DUIM

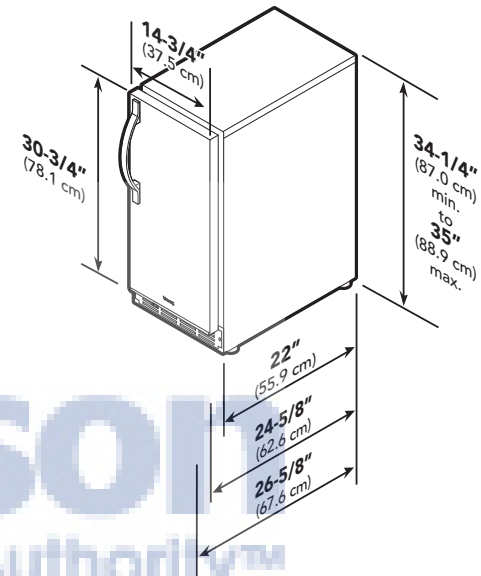

Door Swing

DUIM

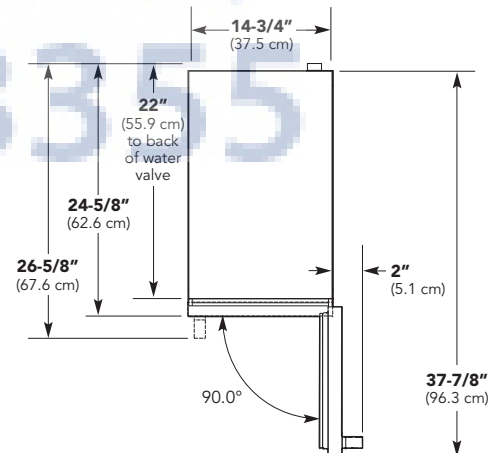

SPECIFICATIONS/DIMENSIONS

CUSTOM PANEL MODEL

Basic Electric Data

- 115 VAC/60 Hz
- Maximum amps - 3.0
- Approximate Shipping Weight - 100 lbs. (45.0 kg)

Dimensions DFIM

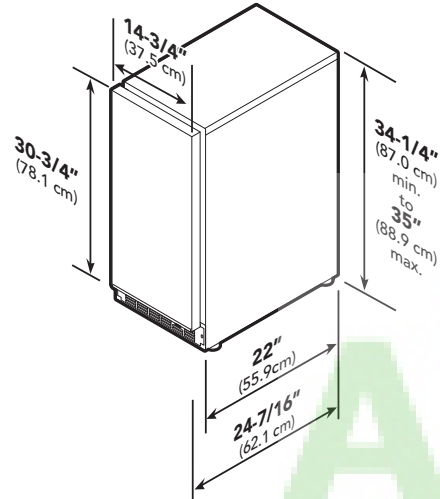

Door Swing DFIM

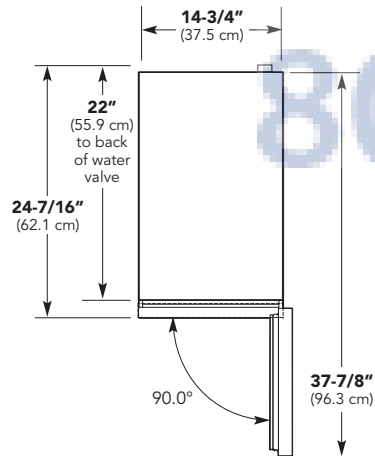

6

FULL OVERLAY PANEL INSTALLATION

NOTE: Weight of wood panel must not exceed 20 lbs.

Wood Screws

1. A #10 pan head wood screw should be used to properly secure the wood panel. A total of 10 screws will be needed.
2. Only use pan head screws.
3. **DO NOT** select a screw that is longer than the wood thickness at the screw locations.
4. Use recommended pilot holes for the frame material. (See chart)

Working Material	Wood Screw Size #10
Hardwood	3/32 (0.24 cm)
Softwood	5/64 (0.20 cm)

Assembling Door Hinge Brackets

(Disregard if hinge brackets are already attached)

1. Attach the top and bottom door hinge brackets to the door with the machine screws and a 5/32" Allen head driver as shown in Figure 1 below.
2. Press in the shoulder bushings to the top and bottom door hinge brackets. Make certain that the shoulder is to the outside of the door as shown in Figure 1 below.
3. Test fit the door to the unit to make certain door will hang correctly. The door is hung correctly when the top of the door is parallel to the top of the unit. Adjustments can be made by loosening the door hinge machine screws and moving the door hinge brackets on the door.
4. Tighten all four (4) machine screws after adjustments have been made.
5. Remove the door from the unit by removing the units top hinge set screw and angling the door off of the bottom hinge pin.

FIGURE 1

Typical Top and Bottom Door Hinge Bracket Assembly

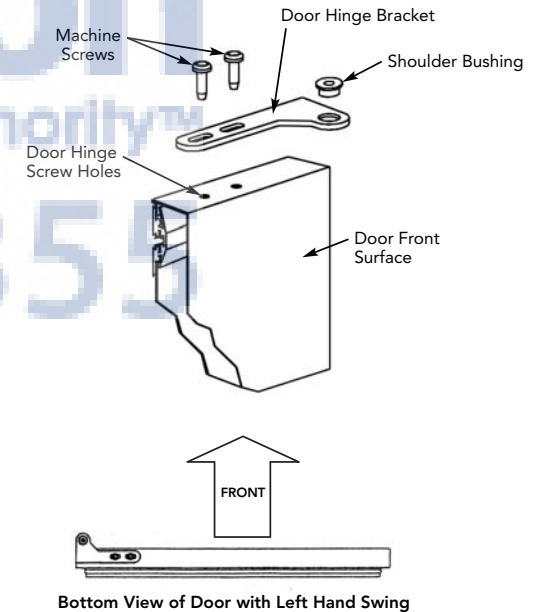

7

Selecting and Preparing the Wood Frame - DFIM Models

**FOR A 3-1/2" TOE KICK
(COVERS THE ENTIRE DOOR FRONT - LEFT HINGE)**

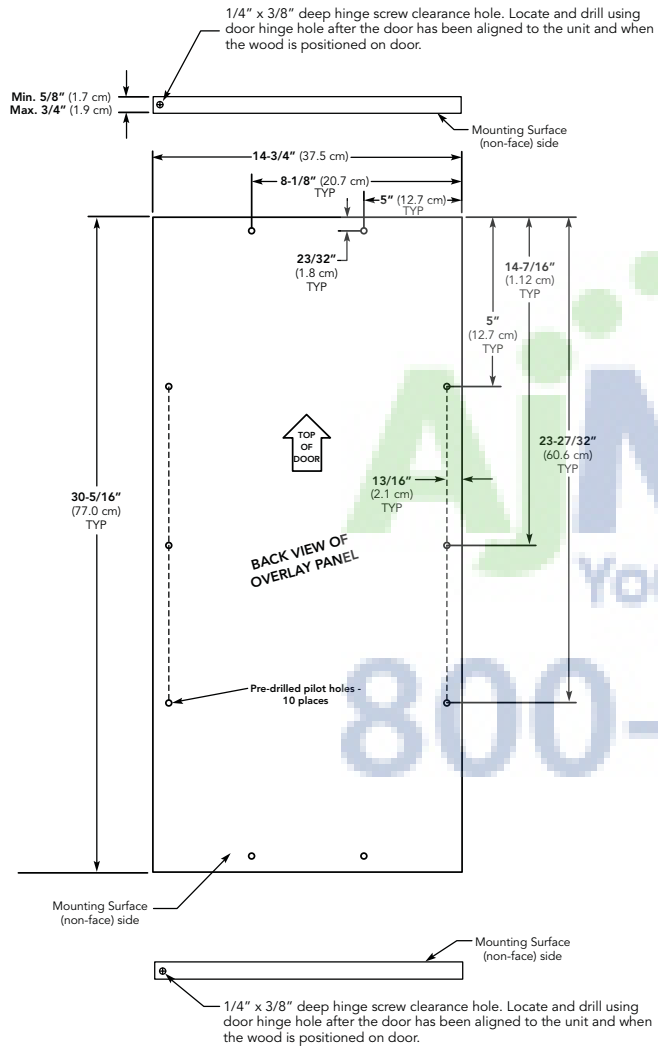

Selecting and Preparing the Wood Frame - DFIM Models

**FOR 3-1/2" TOE KICK
(COVERS THE ENTIRE DOOR FRONT - RIGHT HINGE)**

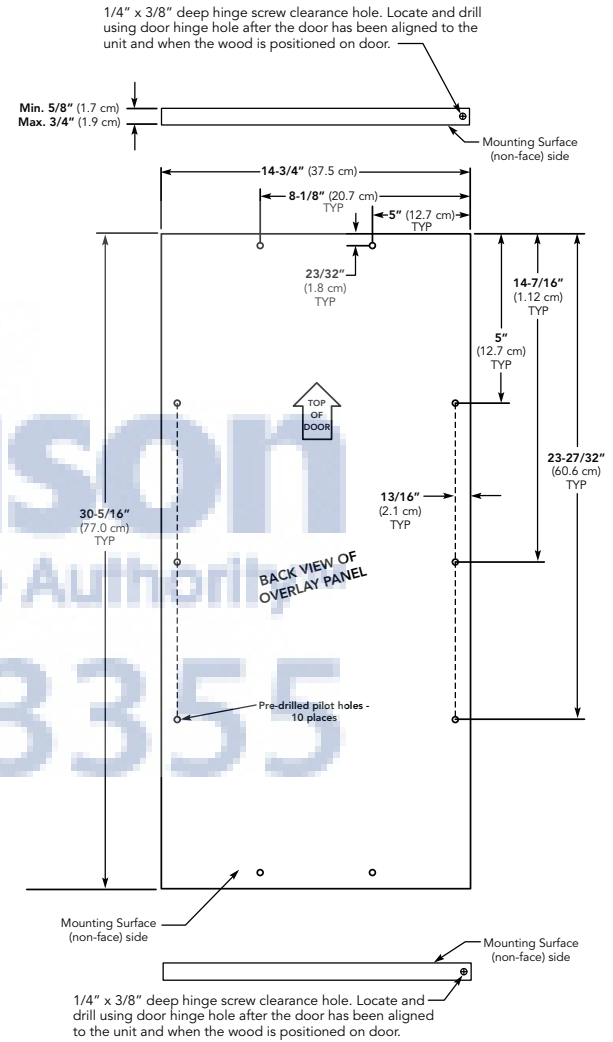

ATTACHING THE OVERLAY PANEL TO THE DOOR

1. If the door is attached to the unit, remove by unscrewing the top Allen head set screw at the top hinge. Remove the door by angling the door off of the bottom hinge pin.
2. Peel back the door gasket to expose the screw holes.
3. Set the overlay panel flush to the front of the door in the desired location. Clamp the overlay panel to the door if necessary.
4. Insert the wood screws through the back of the door into the pilot holes in the overlay panel and tighten.
5. Reinstall the door gasket by pressing into the door channel. Make certain the corners are inserted fully.
6. Install the door to the unit. Use the supplied plastic washer as shown in the figure below.
7. Realigning the door may be necessary. Any final door adjustments can be made using a 5/32" Allen head driver to adjust the door's brackets. (See figure below)
8. Attach the door to the unit by reversing step number 1 above.

Hinge Hardware Installation Details

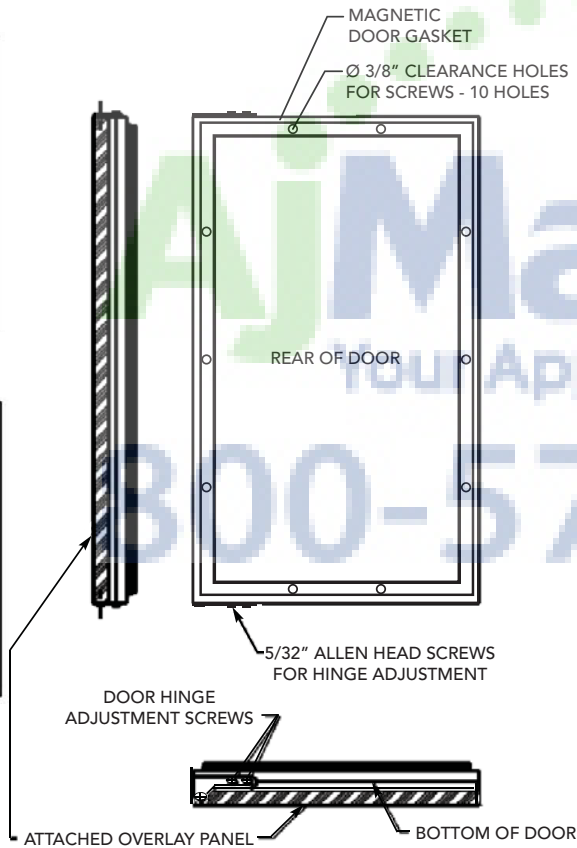
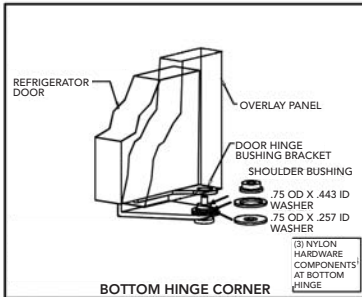
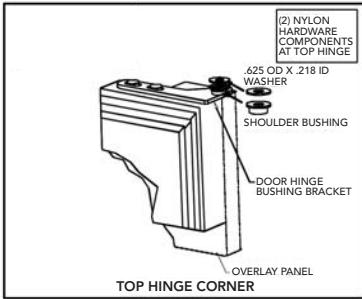

LEG LEVELER INSTALLATION

WARNING

Do not lay unit on top, side, back, or front. If unit is accidentally laid in any position other than right side up, then the unit must remain in the right side up position for at least 24 hours before plugging the unit in.

1. Tip unit backwards so there is (1) foot of clearance on front of the unit. Have someone to assist you in tilting the unit, to prevent it from falling on you while installing the leg levelers.
2. Screw front two leg levelers into the screw impressions. Leg levelers should be screwed in until snug.
3. Repeat steps 1 & 2, with the exception of tipping the unit forwards now, to screw in the back two leg levelers.
4. Your leg levelers are now installed.
5. The unit should be level from front to back and side to side. If floor conditions do not allow the unit to sit level, adjust leg leveler(s) by turning the required leg leveler(s) counter-clockwise to increase their height and clockwise to reduce their height.

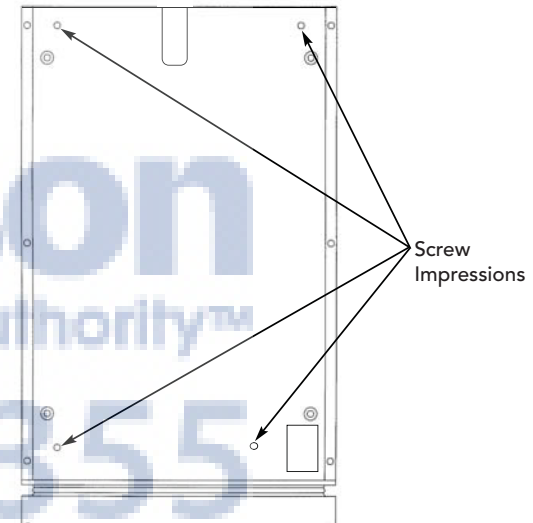

ELECTRICAL CONNECTION

⚠ WARNING

ELECTRICAL SHOCK HAZARD

Failure to follow these instructions could result in fire or electrical shock.

Electrical Requirements

A 115 volt, 60 Hz, AC only 15 amp fused electrical supply is required. (A time delay fuse or circuit breaker is recommended.) It is recommended that a separate circuit, serving only this appliance, be provided.

- **ELECTRICAL GROUND IS REQUIRED ON THIS APPLIANCE.**
- **DO NOT UNDER ANY CIRCUMSTANCES REMOVE THE POWER SUPPLY CORD GROUND PLUG.**
- **DO NOT USE AN EXTENSION CORD.**

Recommended Grounding Methods

For your personal safety, this refrigeration product must be grounded. This appliance is equipped with a 5' power supply cord having a 3-prong grounding plug. To minimize possible shock hazard, the cord must be plugged into a mating 3-prong grounding type wall receptacle grounded in accordance with the National Electrical Code and local codes and ordinances. If the circuit does not have a grounding type receptacle, it is the responsibility and obligation of the customer to exchange the existing receptacle in accordance with the National Electrical Code and applicable local codes and ordinances. The third ground plug **SHOULD NOT**, under any circumstances, be cut or removed. All UL listed refrigerated products are equipped with this type of plug.

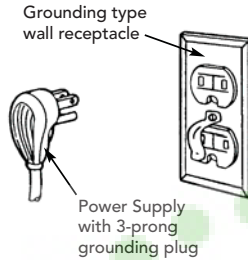

WATER CONNECTION

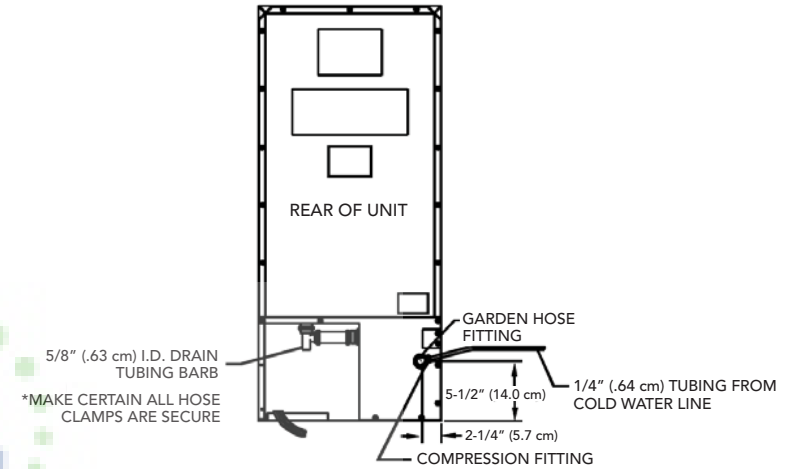

Water Supply

- This ice machine must be connected to a potable, active cold water supply line delivering water pressure at a minimum pressure of 20 psi and maximum of 120 psi.
- Water connection is made through a 1/4" (.64 cm) compression right angle garden hose fitting. **DO NOT use any thread sealers.** *NOTE: The water line fitting supplied with your ice machine is to be used on a 1/4" (.64 cm) copper water supply line only. Do not attach a plastic supply line to your unit using this fitting.*

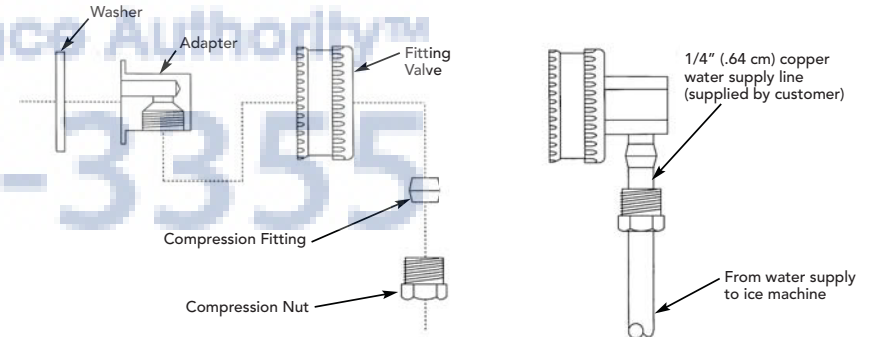

- **A water filter is recommended for this unit.** A quality filter can remove particles as well as remove taste and odors from water.
- Do not use a reverse osmosis water filtration system with the ice machine.
- **Softened water is not recommended.** This will produce mushy, cloudy ice cubes that will stick together.
- **De-ionized water is not recommended.** This water will not form solid ice cubes.
- A water specialist can recommend proper water treatment.
- After installation of water line, turn on water and check for any leaks. Additional tightening may be needed. **DO NOT use any type of thread sealer.**
- Allow extra water line for easy removal of unit and to help prevent the water line from kinking.

DRAIN PLUMBING

Your ice machine uses a gravity drain that requires 5/8" (.63 cm) ID tubing from the back of the ice maker to a plumbed connection to a sanitary sewer (see Gravity Drain drawing below). Remove the access panel, with a 5/16" (0.8 cm) wrench to plumb in drain connection. Gravity drain location for built-in units can be within the area shown in illustration below. **An optional drain pump can be purchased for your ice machine if a gravity drain is not accessible. Observe and follow all local codes when installing an ice machine.**

⚠ WARNING

Failure to use adequate drainage system will result in surrounding water damage and/or poor ice production.

GRAVITY DRAIN

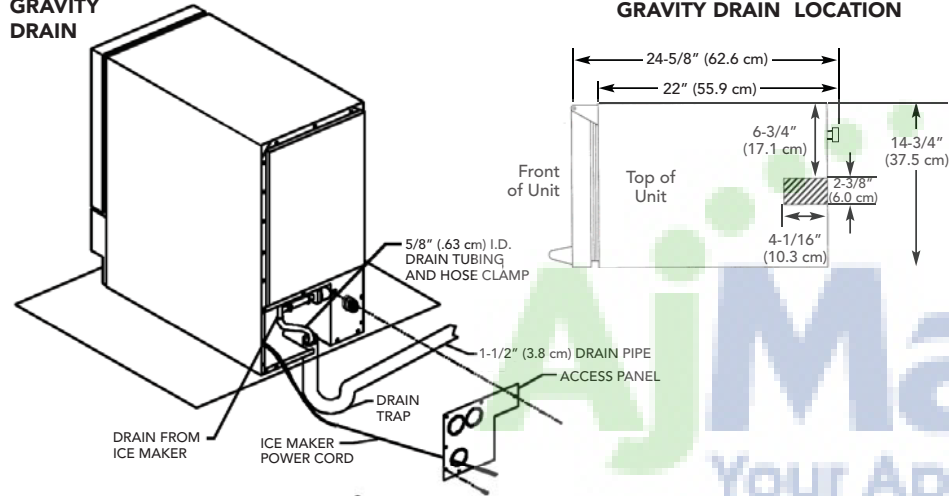

DRAIN PUMP Model Number - VUIM-DP

(Sold separately - see installation instructions supplied with drain pump)

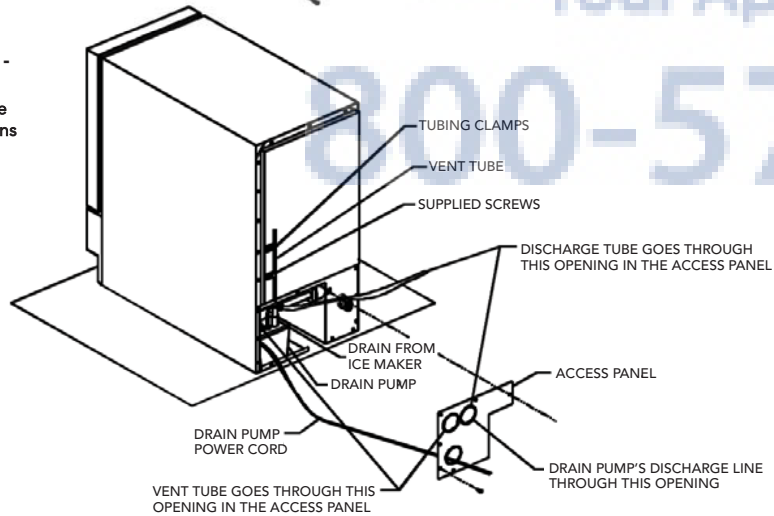

14

ICE MACHINE FEATURES

1. Escutcheon Panel
2. Ice Storage Bin
3. Ice Scoop
4. On/Off/Clean Rocker Switch

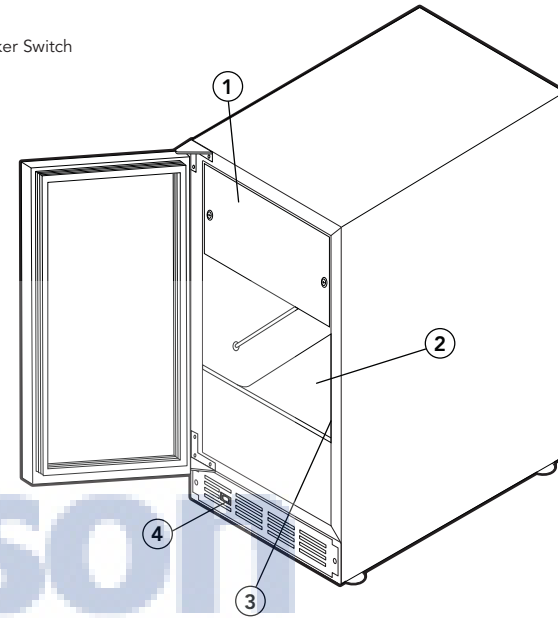

HOW THE ICE MACHINE WORKS

Your ice machine is unique in forming ice. It uses fractional freezing to form a slab of ice that is clear and has less mineral content than the water it is produced from. This is accomplished by running water over the cold evaporator plate which gradually freezes the water to produce the ice slab. Mineral deposits are left in the reservoir.

When the ice slab reaches the correct thickness determined by the temperature of the evaporator plate, the electronic control switches to the harvest cycle to harvest the ice slab. During the harvest cycle, the ice slab falls from the evaporator to the ice grid cutter. Here, the ice slab is cut into 3/4" squares by the grid cutter's low voltage heated wires. During the harvest cycle, the drain valve will remain open for 45 seconds to drain the reservoir of remaining deposits. After that, the water valve will open for 2 minutes providing 2 quarts of water to the reservoir for the next ice production cycle.

The ice machine will keep producing ice until the ice machine's storage bin is full and will restart automatically when ice needs to be replenished in the storage bin.

To begin ice production, turn the switch to the "ON" position.

Ice Machine Safety and Operation Tips

- Avoid leaning on the cabinet door. You may bend the door hinge or tip the unit.
- Exercise caution when sweeping, vacuuming, or mopping near the front of the unit. Damage to the grill and/or switch can occur.
- Periodically clean the inside of the ice machine components and inside of the unit.
- Periodically check and/or clean the front grill and condenser coils.

15

USING YOUR ICE MACHINE

1. Allow your ice machine to run for at least 48 hours to accumulate ice in the ice bin.
2. The unit will cycle off between ice production and ice harvest cycles.
3. Your ice machine will make unusual noises that you do not normally hear from your household refrigerator/freezer. These noises do not mean your ice machine is not functioning properly. They occur as a normal part of the ice machine's operations.
4. The unit will automatically shut down when the ice bin is full.
5. Unplug the ice machine before working on the unit.
6. Keep the ice machine clean for proper ice quality, production, and unit life.
7. Room and water supply temperatures will greatly affect the output of ice in the unit. (See table below.) Ice will also melt away, especially at the start of an empty bin, but will slow down as ice accumulates.

		PRODUCTION RATE (LB/DAY)*	
		WATER TEMPERATURE °F	
ROOM TEMPERATURE °F		50	70
	70	34	32
	80	30	27
	90	23	20

		APPROXIMATE TIME TO FILL BIN (HOURS)*	
		WATER TEMPERATURE °F	
ROOM TEMPERATURE °F		50	70
	70	31	34
	80	41	58
	90	60	82

*NOTE: Due to variables in installation and use, individual results may vary.

Outdoor Use

1. For best performance, install under a counter or shelter. Avoid direct sunlight.
2. If the ice machine is not used for an extended period of time or if temperatures are below 45°F (7.2°C), it is necessary to remove remaining water in the ice making system. (See Preparing Ice Machine for Storage, p. 12).
3. Chlorine gas from swimming pools and spas may discolor stainless steel. (See Cleaning and Maintenance below for instructions on cleaning).

CLEANING AND MAINTENANCE

Any piece of equipment works better and lasts longer when maintained properly and kept clean.

Condenser

The condenser tubing inside the cabinet does not require frequent cleaning; however, satisfactory cooling depends on adequate ventilation over the coils. Be sure that nothing obstructs the required air flow openings in front of the cabinet. Spiders and insects can nest in and around the ice machine causing damage to the unit. Frequently brush or vacuum (twice yearly) lint and dirt from the condenser for efficient performance by unscrewing the grill and kickplate on the bottom front of cabinet.

Cabinet

The cabinet can be washed with mild soap and water and thoroughly rinsed with clear water. Never use abrasive scouring powders.

Interior/Ice Scoop

Wash interior compartment and ice scoop with mild soap and water or a baking soda and water solution. Do not use abrasive powder, solvent, polish cleaner or undiluted detergent.

Stainless Steel Parts

All stainless steel parts should be wiped regularly with hot soapy water. Use a liquid cleaner designed for stainless steel when soapy water will not do the job. **DO NOT USE** bleach, steel wool, abrasive cloths, cleansers, or powders. Do not permit citrus or tomato juice to remain on stainless steel surfaces, as citric acid will permanently discolor stainless steel. **NOTE: Under rare conditions, such as an extremely salty environment, small amounts of rust may accumulate on stainless steel parts. These small amounts of surface rust can easily be removed by apply Soft Scrub® Gel to a damp sponge and wiping with the stainless steel grain. It is important to make sure you wipe with the grain for the most efficient removal of surface rust.**

Brass Parts

CAUTION: All brass parts have an epoxy coating. **DO NOT USE BRASS OR ABRASIVE CLEANERS ON THE BRASS PARTS.** All brass parts should be wiped regularly with hot soapy water. When hot soapy water will not do the job, use every day non-abrasive household cleaners.

Door Gasket

The vinyl gasket may be cleaned with mild soap and water, a baking soda and water solution, or a mild scouring powder.

Painted Surfaces

Wash with warm soapy water. **DO NOT USE** steel wool, abrasive cleansers, ammonia, acids or commercial oven cleaners which may damage the finish.

CLEANING THE ICE MACHINE SYSTEM

Some impurities will remain and buildup in the ice machine and stick to the ice machine's parts over time. This build-up must be removed for proper ice production, ice quality, and ice machine life. Your ice machine is equipped with a cleaning mode that will help in cleaning out these impurities.

⚠ WARNING

Read and follow manufacturer's warnings on ice machine cleaner products.

The ice machine will regularly (at the very least, annually) need to be cleaned of this build-up, depending on use and water hardness. You can use an acid such as one specified for ice machine cleaning or you can use citric acid to remove the build-up. To clean the ice machine:

1. Switch the selector switch to the "OFF" position.
2. Remove the drain plug at the bottom of the reservoir to drain any remaining water and then reinstall.
3. Remove the escutcheon panel.
4. Add cleaning solution to the reservoir. **NOTE: Three quarts of water will automatically be added to the reservoir. Therefore, cleaning solution should not be diluted. Please follow manufacturer's instructions for mixing with 3 quarts of water.**
5. Replace escutcheon panel and close door.
6. Switch selector switch on the grill of the machine to the clean position.
7. The cleaning cycle will end in 49 minutes. The cleaning cycle will automatically rinse the evaporator plate, drain the cleaning solution, and rinse the components.
8. After the cleaning cycle has ended, remove the escutcheon panel again and check that build-up has been removed. The evaporator plate should be clean, shiny, and smooth to the touch. If not and build-up is still visible, repeat the cleaning cycle above. If build-up is removed, continue below.
9. Remove the distributor tube, hose clamp, hose and its rubber ends.
10. Thoroughly clean the inside of the distributor tube and the spray holes. You can use the same cleaning solution as before and an old tooth brush to reach the inside of the distributor tube.
11. Reinstall the rubber end, hose, and hose clamp to the distributor tube and then reinstall the distributor tube to the evaporator with the spray holes pointed to the bottom of the evaporator plate. Reinstall the escutcheon panel.

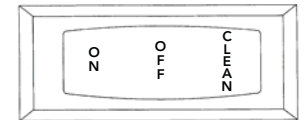

Your ice machine is now clean and sanitized. It can be placed back into operation by switching the selector switch to the "ON" position. Please wait 48 hours for maximum ice production.

PREPARING THE ICE MACHINE FOR STORAGE

If the ice machine is moved, not used for an extended period of time, or will be in a area below 45°F (7.2°C), it is necessary to remove the water from the ice making system.

Step 1: Clean the ice machine (refer to page 11.)

Step 2: Drain and remove water from ice making system.

1. Turn off the water supply to the ice machine.
2. Disconnect the water supply fitting at the inlet of the water valve.
3. Switch the rocker switch to "CLEAN" for approximately 1 minute. This will energize and open the water valve and remove most of the water from the water valve and the water valve's outlet water line to the reservoir.
4. Switch the rocker switch to "OFF". This will energize and open the drain valve to drain the reservoir and the ice machine drain system.
5. Unplug the unit from the electrical outlet.
6. Remove the back panel from the rear of the unit.
7. Disconnect the water valve's outlet water line to the reservoir and drain the remaining water left in the water line trap area.
8. Reconnect the water valve outlet water line and tighten the compression nut to a watertight seal.
9. Reinstall the unit's back panel.
10. Clean and dry the ice machine's storage bin.
11. Prop the door open for air circulation to prevent mold and mildew.
12. Leave the water supply line disconnected or reconnect the supply line and leave it shut off. **DO NOT** turn the water and allow water to enter back into the water valve.

STEP 3: Drain water from optional drain pump, if applicable.

1. Remove the drain pump from the ice machine. (Refer to drain pump installation instructions).
2. Drain the water in the drain pump's reservoir by running the pump upside down and allowing water to drain through the pump's inlet and vent tube fittings.
3. After all water is drained, reinstall the drain pump. Make certain all tubing is installed and all hose clamps are tight. (Refer to drain pump installation instructions).

Step 4: Restart the ice machine when ready for use.

1. With the rocker switch in the "OFF" position, plug the unit into an electrical outlet.
2. Reconnect or turn on the water supply line.
3. Reconnect drain tubing if removed.
4. Turn the rocker switch to the "ON" position.
5. Check the water inlet, drain lines, and fittings for any water leaks.
6. Check drain pump, (if applicable), operation by pouring approximately 2 quarts (1.9 L) of water into the ice storage bin. The drain pump should activate and discharge water. (Refer to drain pump installation instructions). Check for water leaks at all hose connections.

TROUBLESHOOTING GUIDE

PROBLEM	POSSIBLE CAUSE	CORRECTION
Water keeps backing up into ice bin (drain pump).	Drain pump tubing kinked or restricted	Check inlet, discharge, and vent line tubing for any kinks or restrictions and repair as needed.
	Inlet screen to the drain pump is restricted.	Clean the inlet screen to the drain pump.
	Drain pump and/or the ice machine are not level.	Check and level the drain pump and the ice machine if necessary.
The drain pump cycles on and off erratically.	Vent line to the drain pump is restricted or kinked.	Check the vent line for any restrictions or kinks and repair as needed.
	Discharge line is restricted or kinked.	Check the discharge line and connection to the desired drain for any restrictions or kinks and repair as needed.
	The drain pump is not level.	The drain pump must be level. Check for level on the top of the drain pump case and adjust the tubing or use shims to level.

TROUBLESHOOTING GUIDE

PROBLEM	POSSIBLE CAUSE	CORRECTION
Unit does not operate.	The unit is unplugged	Plug in the unit.
	Breaker is tripped or fuse is blown.	Reset breaker or replace fuse. Check to make sure there is not a short in the electrical circuit.
	Ice machine selector switch is in the "OFF" position.	Set the rocker switch on the grill of the machine to the "ON" position.
Unit operates but does not produce any ice.	The unit has just been started and it has been less than 6 hours.	Ice produced when the unit is initially started will melt off in the bin. This is normal operation. Check the unit in 24 hours for ice accumulation in the bin.
	Typical ice production cycle can take up to 1.5 hours.	Check the unit in 24 hours for ice accumulation in the bin.
	The selector switch is in the "OFF" or "CLEAN" position.	Set the rocker switch on the grill of the ice machine to the "ON" position.
	No water in the reservoir.	Make sure that the reservoir drain plug is installed. Check the water line to the unit to make sure it is on and that there are no restrictions or kinks in the line. Check all filters to make sure they are not restricted or plugged.
	Distributor tube is restricted.	See "Cleaning the Ice Machine System" section for cleaning the unit for proper operation.
	Build-up of deposits on evaporator plate.	See "Cleaning the Ice Machine System" section for cleaning the unit for proper operation.
	Condenser fan air flow is restricted	Make certain the grill in the front of the unit is free and open for proper air circulation. Check and clean the condenser coil by removing the grill in the front of the unit. Clean the condenser with a vacuum and brush attachment.
	Room and/or water temperature is too warm.	Move the unit to an area where ambient temperature is below 90°F. The unit should not be placed next to a heat source such as an oven. Check for cold water connection.
	Leaking drain valve	See "Cleaning the Ice Machine System" section for cleaning the unit. This will also dissolve and flush out foreign material in the drain valve.
	Inadequate drain system	Restriction in drain lines will cause ice in the bin to melt. If using a gravity drain, make certain there are no kinks or restrictions in the drain lines. If using a drain pump, check the inlet screen, discharge line, and vent line for any build-up or restrictions.
Ice is not clear	Grid cutter is unplugged	Plug in the grid cutter so that ice slabs can be cut into cubes.
	Low water in level in reservoir.	Make sure that the reservoir drain plug is installed properly. Check the water line to the unit to make sure there are no restrictions or kinks in the line. Check all filters to make sure they are not restricted or plugged.
	Softened water supply	Make certain that water line is not connected to the water softener.
	Room temperature is too cold.	Move to an area where room temperature is above 55°F.

TROUBLESHOOTING GUIDE

PROBLEM	POSSIBLE CAUSE	CORRECTION
Ice cubes are too small (less than 1/2" thick)	Low ice consumption	Ice is slowly melting in the ice bin and will affect the size of the ice cube. This is normal operation. When the ice bin needs to be replenished, cubes will return to regular size.
	Not enough water in reservoir.	Make sure that the reservoir drain plug is installed properly. Check the water line to the unit to make sure there are no restrictions or kinks in the line. Check all filters to make sure they are not restricted or plugged.
	Distributor tube is restricted.	See "Cleaning the Ice Machine System" section for cleaning the unit for proper operation.
	Build-up of deposits on evaporator plate.	See "Cleaning the Ice Machine System" section for cleaning the unit for proper operation.
	Leaking drain valve	See "Cleaning the Ice Machine System" section for cleaning the unit. Cleaning the unit will also dissolve and flush out foreign material in the drain valve.
	Inadequate drain system.	Restriction in drain lines will cause ice in the bin to melt to a thinner cube. If using a gravity drain, make certain there are no kinks or restrictions in the drain lines. If using a drain pump, check the inlet screen, discharge line, and vent line for any build-up or restrictions.
Ice cubes are too big (greater than 3/4" thick)	Room temperature is too warm.	Move to an area where temperature is below 90°F.
	Ice slab not releasing.	See "Cleaning the Ice Machine System" section for cleaning the unit for proper operation.
Hollow ice slab	Condenser fan air flow is restricted.	Make certain the grill in the front of the unit is free and open for proper air circulation. Check and clean the condenser coil by removing the grill in the front of the unit. Clean the condenser with a vacuum and brush attachment.
	Room temperature is too warm.	Move to area where temperature is below 90°F.
	Distributor tube is restricted.	See "Cleaning the Ice Machine System" section for cleaning the unit for proper operation.
	Build-up of deposits on evaporator plate.	See "Cleaning the Ice Machine System" section for cleaning the unit for proper operation and cube size.
Unit continues to run and produce ice.	Low water level in reservoir.	Make sure that the reservoir drain plug is installed properly. Check the water line to the unit to make sure there are no restrictions or kinks in the line. Check all filters to make sure they are not restricted or plugged.
	Ice bin is not full.	The unit will automatically shut down when ice reaches the sensing tube.
	Ice bin is full.	The unit will automatically shut down when ice reaches the sensing tube and has completed the harvest of the ice slab.
	Room temperature is too warm.	Move to an area where room temperature is below 90°F.
Ice cubes are sticking together.	Ice machine is not level.	Use a level to check the unit from side to side and front to rear.
	Ice consumption is low.	Use the ice in the bin frequently. Ice will stick together if left in insulated bin over long periods of time.
	Room temperature is too warm	Move the unit to an area where temperature is below 90°F.

TROUBLESHOOTING GUIDE

PROBLEM	POSSIBLE CAUSE	CORRECTION
Low ice production. Unit is running, has run over a 48 hour period, and there is little ice in bin.	Low water level in reservoir.	Make sure that the reservoir drain plug is installed properly. Check the water line to the unit to make sure there are no restrictions or kinks in the line. Check all filters to make sure they are not restricted or plugged.
	Distributor tube is restricted.	See "Cleaning the Ice Machine System" section for cleaning the unit for proper operation.
	Build-up of deposits on evaporator plate.	See "Cleaning the Ice Machine System" section for cleaning the unit for proper operation.
	Inadequate drain system.	Restriction in drain lines will cause ice in the bin to melt to a thinner cube. If using a gravity drain, make certain there are no kinks or restrictions in the drain lines. If using a drain pump, check the inlet screen, discharge line, and vent line for any build-up or restrictions.
	Condenser fan air flow is restricted	Make certain the grill in the front of the unit is free and open for proper air circulation. Check and clean the condenser coil by removing the grill in the front of the unit. Clean the condenser with a vacuum and brush attachment.
Grid cutter is not cutting ice slab.	The selector switch is not in the "ON" position.	Set the rocker switch on the grill of the ice machine to the "ON" position.
	The grid cutter is not plugged into receptacle.	Remove the escutcheon panel and plug the grid cutter into the receptacle on the side of the liner.
Ice level is too low.	It has not had time to cut through the slab.	It can take up to 35 minutes to cut through a harvested ice slab. This is normal operation.
	The ice machine is not level	Use a level to check the unit from side to side and front to rear.
Ice level is too high.	Room temperature is too cold.	Move the unit to an area where temperature is above 55°F.
	The selector switch is not in the "ON" position.	Set the rocker switch on the grill of the ice machine to the "ON" position.
	The ice machine is not level	Use a level to check the unit from side to side and front to rear.
	Room temperature is too warm.	Move the unit to an area where temperature is below 90°F.
Water keeps backing up into ice bin (gravity drain).	Ice deflector is not in place or secured properly.	Check to see that the ice deflector is in place and secured below the grid cutter.
	Bin level sensing tube needs adjusting.	Adjust the bin level sensing tube by simply pressing directly down on the tube 5 inches from the front of the tube to get a desired bin level.
	Inadequate drain system.	Restriction or improperly installed drain lines will cause water to back up into the ice bin. Make certain there are no kinks or restrictions in the drain lines. If necessary, consult a qualified plumber.
	Foreign material in ice bin drain	Foreign material is restricting or blocking the ice bin drain located at the right rear corner of the ice bin. The drain will need to be cleared.

FINAL PREPARATION

1. Some stainless steel parts may have a plastic protective wrap which must be peeled off. The interior of the ice machine should be washed thoroughly with hot, soapy water, rinsed and wiped dry to remove film residue and any installation dust or debris before being used. Solutions stronger than soap and water are rarely needed.
2. All stainless steel parts should be wiped with hot soapy water. If buildup occurs, do not use steel wool, abrasive cloths, cleaners, or powders. If it is necessary to scrape stainless steel to remove encrusted materials, soak with hot, wet cloths to loosen the material, then use a wood or nylon scraper. Do not use a metal knife, spatula, or any other metal tool to scrape stainless steel; scratches are almost impossible to remove.

SERVICE INFORMATION

If service is required, call your dealer or authorized service agency. The name of the authorized service agency can be obtained from the dealer or distributor in your area.

Have the following information readily available.

- Model number
- Serial number
- Date purchased
- Name of dealer from whom purchased

Clearly describe the problem that you are having. If you are unable to obtain the name of an authorized service agency, or if you continue to have service problems, contact Viking Range Corporation at 1-888-VIKING1 (845-4641), or write to:

**VIKING RANGE CORPORATION
PREFERRED SERVICE
1803 Hwy 82W
Greenwood, Mississippi 38930 USA**

Record the information indicated below. You will need it if service is ever required. The model and serial number for your ice machine are located on the front of the unit at the base of the door frame.

Model Number _____ Serial Number _____

Date of Purchase _____ Date Installed _____

Dealer's Name _____

Address _____

If service requires installation of parts, use only authorized parts to insure protection under the warranty.

KEEP THIS MANUAL FOR FUTURE REFERENCE.

**UNDERCOUNTER/FREESTANDING ICE MACHINE WARRANTY
(Units certified for Indoor Use)**

TWO YEAR FULL WARRANTY

Undercounter/freestanding ice machines and all of their components and accessories, except as detailed below, are warranted to be free from defects in material or workmanship under normal household use for a period of two (2) years from the date of original retail purchase. Viking Range Corporation, warrantor, agrees to repair or replace, at its option, any part which fails or is found to be defective during the warranty period

*Painted and decorative items are warranted to be free from defective materials or workmanship for a period of ninety (90) days from the date of original retail purchase. ANY DEFECTS MUST BE REPORTED TO THE SELLING DEALER WITHIN NINETY (90) DAYS FROM DATE OF ORIGINAL RETAIL PURCHASE.

SIX YEAR FULL WARRANTY

Any sealed refrigeration system component, as listed below, is warranted to be free from defective materials or workmanship in normal household use during the third through the sixth year from the date of original retail purchase. Viking Range Corporation, warrantor, agrees to repair or replace, at its option, any part which fails or is found to be defective during the warranty period.

Sealed Refrigeration System Components: Compressor, Evaporator, Condenser, Connecting Tubing, Dryer/Strainer

TWELVE YEAR LIMITED WARRANTY

Any sealed refrigeration system component, as listed above, which fails due to defective materials or workmanship in normal household use during the seventh through the twelfth year from the date of original retail purchase will be repaired or replaced, free of charge for the part itself, with the owner paying all other costs, including labor.

NINETY (90) DAY RESIDENTIAL PLUS WARRANTY This warranty applies to applications where use of the product extends beyond normal residential use. Examples are, but not limited to, bed and breakfasts, fire stations, private clubs, churches, etc. This warranty excludes all commercial locations such as restaurants, food service locations and institutional food service locations.

This warranty extends to the original purchaser of the product warranted hereunder and to each transferee owner of the product during the term of the warranty.

This warranty shall apply to products purchased and located in the United States and Canada. Products must be purchased in the country where service is requested. Warranty labor shall be performed by an authorized Viking Range Corporation service agency or representative. Warranty shall not apply to damage resulting from abuse, accident, natural disaster, loss of electrical power to the product for any reason, alteration, improper installation, improper operation or repair or service to the product by anyone other than an authorized Viking Range Corporation service agency or representative. Warranty shall not apply to damage resulting from indoor units being used in outdoor situations. This warranty does not apply to commercial usage. Warrantor is not responsible for consequential or incidental damage whether arising out of breach of warranty, breach of contract, or otherwise. Some jurisdictions do not allow the exclusion or limitation of incidental or consequential damages, so the above limitation or exclusion may not apply to you.

Owner shall be responsible for proper installation, providing normal care and maintenance, providing proof of purchase upon request, and making the appliance reasonably accessible for service. If the product or one of its component parts contains a defect or malfunction during the warranty period, after a reasonable number of attempts by the warrantor to remedy the defects or malfunctions, the owner is entitled to either a refund or replacement of the product or its component part or parts. Replacement of a component part includes its free installation. Warrantor's liability on any claim of any kind, with respect to the goods or services covered hereunder, shall in no case exceed the price of the goods or service or part here of which gives rise to the claim.

WARRANTY SERVICE: Under the terms of this warranty, service must be performed by a factory authorized Viking Range Corporation service agent or representative. Service will be provided during normal business hours, and labor performed at overtime or premium rates shall not be covered by this warranty. To obtain warranty service, contact the dealer from whom the product was purchased, an authorized Viking Range Corporation service agent, or Viking Range Corporation. Provide model and serial number and date of original purchase. For the name of your nearest authorized Viking Range Corporation service agency, call the dealer from whom the product was purchased or Viking Range Corporation. **IMPORTANT:** Retain proof of original purchase to establish warranty period.

The return of the Owner Registration Card is not a condition of warranty coverage. You, however, should return the Owner Registration Card so that Viking Range Corporation can contact you should any question of safety arise which could affect you.

Any implied warranties of merchantability and fitness applicable to the above described undercounter ice machine are limited in duration to the period of coverage of the applicable express written limited warranties set forth above. Some jurisdictions do not allow limitations on how long an implied warranty lasts, so the above limitation may not apply to you. This warranty gives you specific rights, and you may also have other rights which may vary from jurisdiction to jurisdiction.

UNDERCOUNTER/FREESTANDING ICE MACHINE WARRANTY
(Units certified for Outdoor Use)

ONE YEAR FULL WARRANTY

Undercounter/freestanding ice machines and all of their components and accessories, except as detailed below, are warranted to be free from defects in material or workmanship under normal household use for a period of one (1) year from the date of original retail purchase. Viking Range Corporation, warrantor, agrees to repair or replace, at its option, any part which fails or is found to be defective during the warranty period.

*Painted and decorative items are warranted to be free from defective materials or workmanship for a period of ninety (90) days from the date of original retail purchase. ANY DEFECTS MUST BE REPORTED TO THE SELLING DEALER WITHIN NINETY (90) DAYS FROM DATE OF ORIGINAL RETAIL PURCHASE.

FIVE YEAR LIMITED WARRANTY

Any sealed refrigeration system component, as listed below, is warranted to be free from defective materials or workmanship in normal household use during the second through the fifth year from the date of original retail purchase. Viking Range Corporation, warrantor, agrees to repair or replace, at its option, any part which fails or is found to be defective during the warranty period.

Sealed Refrigeration System Components: Compressor, Evaporator, Condenser, Connecting Tubing, Dryer/Strainer

It is recommended that in temperatures above 110°F (43.0°C) and below 45°F (7.2°C) the unit be shut off. The normal operating range for the unit is between 45°F (7.2°F) and 110°F (43.0°C).

NINETY (90) DAY RESIDENTIAL PLUS WARRANTY This warranty applies to applications where use of the product extends beyond normal residential use. Examples are, but not limited to, bed and breakfasts, fire stations, private clubs, churches, etc. This warranty excludes all commercial locations such as restaurants, food service locations and institutional food service locations.

This warranty extends to the original purchaser of the product warranted hereunder and to each transferee owner of the product during the term of the warranty.

This warranty shall apply to products purchased and located in the United States and Canada. Products must be purchased in the country where service is requested. Warranty labor shall be performed by an authorized Viking Range Corporation service agency or representative. Warranty shall not apply to damage resulting from abuse, accident, natural disaster, loss of electrical power to the product for any reason, alteration, improper installation, improper operation or repair or service to the product by anyone other than an authorized Viking Range Corporation service agency or representative. Warranty shall not apply to damage resulting from indoor units being used in outdoor situations. This warranty does not apply to commercial usage. Warrantor is not responsible for consequential or incidental damage whether arising out of breach of warranty, breach of contract, or otherwise. Some jurisdictions do not allow the exclusion or limitation of incidental or consequential damages, so the above limitation or exclusion may not apply to you.

Owner shall be responsible for proper installation, providing normal care and maintenance, providing proof of purchase upon request, and making the appliance reasonably accessible for service. If the product or one of its component parts contains a defect or malfunction during the warranty period, after a reasonable number of attempts by the warrantor to remedy the defects or malfunctions, the owner is entitled to either a refund or replacement of the product or its component part or parts. Replacement of a component part includes its free installation. Warrantor's liability on any claim of any kind, with respect to the goods or services covered hereunder, shall in no case exceed the price of the goods or service or part there of which gives rise to the claim.

WARRANTY SERVICE: Under the terms of this warranty, service must be performed by a factory authorized Viking Range Corporation service agent or representative. Service will be provided during normal business hours, and labor performed at overtime or premium rates shall not be covered by this warranty. To obtain warranty service, contact the dealer from whom the product was purchased, an authorized Viking Range Corporation service agent, or Viking Range Corporation. Provide model and serial number and date of original purchase. For the name of your nearest authorized Viking Range Corporation service agency, call the dealer from whom the product was purchased or Viking Range Corporation. **IMPORTANT:** Retain proof of original purchase to establish warranty period.

The return of the Owner Registration Card is not a condition of warranty coverage. You, however, should return the Owner Registration Card so that Viking Range Corporation can contact you should any question of safety arise which could affect you.

Any implied warranties of merchantability and fitness applicable to the above described undercounter/freestanding ice machine are limited in duration to the period of coverage of the applicable express written limited warranties set forth above. Some jurisdictions do not allow limitations on how long an implied warranty lasts, so the above limitation may not apply to you. This warranty gives you specific rights, and you may also have other rights which may vary from jurisdiction to jurisdiction.