

QUANTUM

SERIES

INNOVATIVE REHAB SOLUTIONS



OWNER'S MANUAL

Including Model: Quantum 1402

Pride
Mobility Products Corp.
www.pridemobility.com

1-800-800-8586 (US) 1-888-570-1113 (Canada)

SAFETY GUIDELINES



WARNING! A Quantum Rehab Specialist or a qualified technician must perform the initial setup of this power chair and must perform all of the procedures in this manual.

The symbols below are used throughout this owner's manual and on the power chair to identify warnings and important information. It is very important for you to read them and understand them completely.



WARNING! Indicates a potentially hazardous condition/situation. Failure to follow designated procedures can cause either personal injury, component damage, or malfunction. On the product, this icon is represented as a black symbol on a yellow triangle with a black border.



MANDATORY! These actions should be performed as specified. Failure to perform mandatory actions can cause personal injury and/or equipment damage. On the product, this icon is represented as a white symbol on a blue dot with a white border.



PROHIBITED! These actions are prohibited. These actions should not be performed at any time or in any circumstances. Performing a prohibited action can cause personal injury and/or equipment damage. On the product, this icon is represented as a black symbol with a red circle and red slash.

Quick Reference Information

Quantum Rehab Specialist: _____

Address: _____

Phone Number: _____

Purchase Date: _____

NOTE: This owner's manual is compiled from the latest specifications and product information available at the time of publication. We reserve the right to make changes as they become necessary. Any changes to our products may cause slight variations between the illustrations and explanations in this manual and the product you have purchased. The latest/current version of this manual is available on our website.



Copyright © 2007

Pride Mobility Products Corp.

INFMANU2669/Rev B/ October 2007

C O N T E N T S

I. INTRODUCTION	4
II. SAFETY	5
III. YOUR POWER CHAIR.....	17
IV. ASSEMBLY.....	21
V. COMFORT ADJUSTMENTS.....	23
VI. DISASSEMBLY	29
VII. BATTERIES AND CHARGING	30
VIII. CARE AND MAINTENANCE	35
IX. WARRANTY	41
APPENDIX I - SPECIFICATIONS.....	43

I . I N T R O D U C T I O N

SAFETY

WELCOME to Quantum Rehab, a division of Pride Mobility Products Corporation (Pride). The power chair you have purchased combines state-of-the-art components with **safety**, comfort, and styling in mind. We are confident that these design features will provide you with the conveniences you expect during your daily activities. Once you understand how to **safely** operate and care for your power chair, it should give you years of trouble free operation and service.

Read and follow all instructions, warnings, and notes in this manual before attempting to operate your power chair for the first time. You must also read all instructions, warnings, and notes contained in any supplemental instructional booklets for the controller, front riggings, and/or seating system that accompanied your power chair before initial operation. Your **safety** depends upon you, as well as your provider, caretaker, or healthcare professional in using good judgement.

If there is any information in this manual which you do not understand, or if you require additional assistance for setup or operation, please contact your Quantum Rehab Specialist. **Failure to follow the instructions in this manual and those located on your power chair can lead to personal injury and/or damage to the power chair, and may void the warranty.**

PURCHASER'S AGREEMENT

By accepting delivery of this product, you promise that you will not change, alter, or modify this product or remove or render inoperable or unsafe any guards, shields, or other safety features of this product; fail, refuse, or neglect to install any retrofit kits from time to time provided by Pride to enhance or preserve the safe use of this product.

SHIPPING AND DELIVERY

Before using your power chair, make sure your delivery is complete as some components may be individually packaged. If you do not receive a complete delivery, please contact your Quantum Rehab Specialist immediately. Where damage has occurred during transport, either to the packaging or content, please contact the delivery company responsible.

INFORMATION EXCHANGE

We want to hear your questions, comments, and suggestions about this manual. We would also like to hear about the safety and reliability of your new power chair, and about the service you received from your Quantum Rehab Specialist.

Please notify us of any change of address, so we can keep you apprised of important information about safety, new products, and new options that can increase your ability to use and enjoy your power chair. Please feel free to contact us at the address below:

USA:

Pride Mobility Products Corporation
Attn.: Customer Care Department
182 Susquehanna Avenue
Exeter, PA 18643-2694
customercare@pridemobility.com
1-800-424-8205

Canada:

Pride Mobility Products Company
380 Vansickle Road Unit 350
St. Catharines, Ontario L2R 6P7
1-888-570-1113

NOTE: If you ever lose or misplace your product registration card or your copy of this manual, contact us and we will be glad to send you a new one immediately.

II. SAFETY

PRODUCT SAFETY SYMBOLS

The symbols below are used on the power chair to identify warnings, mandatory actions, and prohibited actions. It is very important for you to read and understand them completely.



Read and follow the information in the owner's manual.



Do not allow unsupervised children to play near the power chair while the batteries are charging.



Maximum seating weight.



Keep your hands away from the tires when driving. Be aware that loose fitting clothing can become caught in drive tires.



Use correct tie-down points for controller harness to prevent the harness from getting caught in the drive tires or pinched in the seat frame, or damaged when passing through doorways.



Avoid exposure to rain, snow, ice, salt, or standing water whenever possible. Maintain and store in a clean and dry condition.

II. SAFETY



Do not lift the mobility vehicle while seated in it.



Do not lift the mobility vehicle while seated in it.

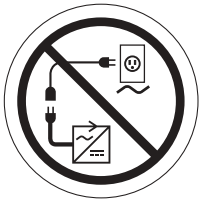

Do not connect an extension cord to the AC/DC converter or the battery charger.



Removal of grounding prong can create electrical hazard. If necessary, properly install an approved 3-pronged adapter to an electrical outlet having 2-pronged plug access.



Wear safety goggles.



Corrosive chemicals contained in battery.

II. SAFETY



EMI-RFI - This product has been tested and passed at an immunity level of 20 V/m.



Explosive conditions exist!



Use only AGM or Gel-Cell batteries to reduce the risk of leakage or explosive conditions.

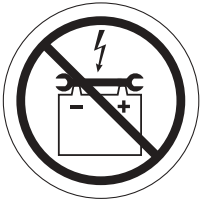

Keep tools and other metal objects away from battery terminals.

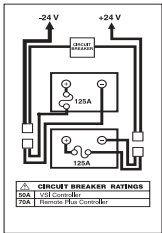

Battery Set Configuration:

+ = Positive (Red) Terminal Post

- = Negative (Black) Terminal Post

Connect Red wire to Red Positive (+) Terminal Post

Connect Black wire to Black Negative (-) Terminal Post



Do not use batteries with different amp-hour (Ah) capacities. Do not mix old and new batteries. Always replace both batteries at the same time.

II. SAFETY



Battery charger for indoor use only.



Disposal and recycling - Contact your Quantum Rehab Specialist for information on proper disposal and recycling of your Pride product and its packaging.



Locked and in drive mode.

Place unit on level ground and stand to one side when changing from drive mode to freewheel mode or freewheel mode to drive mode.

Unlocked and in freewheel mode.



Do not place power chair in freewheel mode on a decline.



Do not place power chair in freewheel mode on an incline.



Contains Lead.

II. SAFETY

GENERAL GUIDELINES



MANDATORY! Do not operate your new power chair for the first time without completely reading and understanding this owner's manual.

Your power chair is a state-of-the-art life-enhancement device designed to increase mobility. Pride provides an extensive variety of products to best fit the individual needs of the power chair user. Please be aware that the final selection and purchasing decision regarding the type of power chair to be used is the responsibility of the power chair user, who is capable of making such a decision, and his/her healthcare professional (i.e., medical doctor, physical therapist, etc.).

The contents of this manual are based on the expectation that a mobility device expert has properly fitted the power chair to the user and has assisted the prescribing healthcare professional and/or the Quantum Rehab Specialist in the instruction process for the use of the product.

There are certain situations, including some medical conditions, where the power chair user will need to practice operating the power chair in the presence of a trained attendant. A trained attendant can be defined as a family member or care professional specially trained in assisting a power chair user in various daily living activities.

As you begin using your power chair during daily activities, you will probably encounter situations in which you will need some practice. Simply take your time and you will soon be in full and confident control as you maneuver through doorways, on and off of elevators, up and down ramps, and over moderate terrain.

Below are some precautions, tips, and other safety considerations that will help you become accustomed to operating your power chair safely.

Modifications

Pride has designed and engineered your power chair to provide maximum mobility and utility. A wide range of accessories is available from your Quantum Rehab Specialist to further customize your power chair to better suit your needs and/or preferences. However, under no circumstances should you modify, add, remove, or disable any feature, part, or function of your power chair.



WARNING! Do not modify your power chair in any way not authorized by Pride. Do not use accessories if they have not been tested or approved for Pride products.

Pre-Ride Safety Check

Get to know the feel of your power chair and its capabilities. Pride recommends that you perform a safety check before each use to make sure your power chair operates smoothly and safely.

Perform the following inspections prior to using your power chair:

- Check for proper tire inflation. Maintain but do not exceed **35 psi (2.4 bar)** in each tire if equipped with pneumatic tires.
- Check all electrical connections. Make sure they are tight and not corroded.
- Check all controller connections to the power base. Make sure they are secured properly.
- Check the brakes. See VIII. "Care and Maintenance."
- Check battery charge. See VII. "Batteries and Charging."

NOTE: *If you discover a problem, contact your Quantum Rehab Specialist for assistance.*

II. SAFETY

Weight Limitations

Your power chair is rated for a maximum weight capacity. Please refer to the specifications table for this limit.



MANDATORY! Stay within the specified weight capacity of your power chair. Exceeding the weight capacity voids your warranty. Pride will not be held responsible for injuries and/or property damage resulting from failure to observe weight limitations.



WARNING! Do not carry passengers on your power chair. Carrying passengers on your power chair may affect the center of gravity, resulting in a tip or a fall.

Tire Inflation

If your power chair is equipped with pneumatic tires, you should check or have the air pressure checked regularly. Proper inflation pressures will prolong the life of your tires and help ensure the smooth operation of your power chair.



WARNING! It is important that 35 psi (2.4 bar) tire pressure be maintained in pneumatic tires at all times. Do not underinflate or overinflate your tires. Low pressure may result in loss of control, and overinflated tires may burst. Failure to maintain 35 psi (2.4 bar) tire pressure in pneumatic tires at all times may result in tire and/or wheel failure.

WARNING! Inflate your power chair drive tires from a regulated air source with an available pressure gauge. Inflating your tires from an unregulated air source could overinflate them, resulting in a burst tire.

Incline Information

More and more buildings have ramps with specified degrees of inclination, designed for easy and safe access. Some ramps may have turning switchbacks (180-degree turns) that require you to have good cornering skills on your power chair.

- Proceed with extreme caution as you approach the downgrade of a ramp or other incline.
- Take wide swings with your power chair's front wheels around any tight corners. If you do that, the power chair's rear wheels will follow a wide arc, not cut the corner short, and not bump into or get hung up on any railing corners.
- When driving down a ramp, keep the power chair's speed adjustment set to the slowest speed setting to ensure a safely controlled descent.
- Avoid sudden stops and starts.

When climbing an incline, try to keep your power chair moving. If you must stop, start up again slowly and then accelerate cautiously. When driving down an incline, set your power chair to the slowest speed setting and drive in the forward direction only. If your power chair starts to move down the incline faster than you anticipated or desired, allow it to come to a complete stop by releasing the joystick, then push the joystick forward slightly to ensure a safely controlled descent.



WARNING! When on any sort of an incline or decline, never place the power chair in freewheel mode while seated on it or standing next to it.

WARNING! When climbing an incline, do not zigzag or drive at an angle up the face of the incline. Drive your power chair straight up the incline. This greatly reduces the possibility of a tip or a fall. Always exercise extreme caution when negotiating an incline.

WARNING! You should not travel up or down a potentially hazardous incline (i.e., areas covered with snow, ice, cut grass, or wet leaves).



WARNING! Never travel down an incline backward. Doing so may cause the power chair to tip. Always exercise extreme caution when negotiating an incline.

WARNING! If your power chair is equipped with a reclining seatback, do not attempt to negotiate inclines with the seat in a reclined position. Do not attempt to negotiate obstacles with the seat in a reclined position unless an attendant is present to help stabilize the chair. Failure to heed may result in the power chair tipping over.

II. SAFETY



WARNING! Even though your power chair is capable of climbing slopes greater than those illustrated in figure 1, do not, under any circumstances, exceed the incline guidelines or any other specifications presented in this manual. Doing so could cause instability in your power chair.

In compliance with the Americans with Disabilities Act of 1990, all handicap public access ramps are required to have a maximum slope of 5° (8.7%). Therefore, Pride recommends that the maximum slope of an incline you attempt to safely ascend or descend on your power chair does not exceed 5° (8.7%). See figure 1.



WARNING! Any attempt to climb or descend a slope steeper than 5° (8.7%) may put your power chair in an unstable position and cause it to tip.

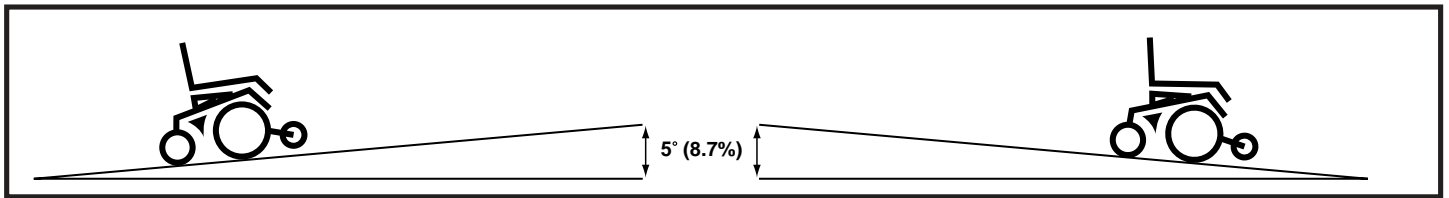

Figure 1. Maximum Safe Angle (Ascending and Descending)

Freewheel Mode

Your power chair is equipped with two manual freewheel levers to allow for manual maneuverability by a trained attendant. For more information about how to place your power chair into and out of freewheel mode, see III. “Your Power Chair.”



WARNING! Do not use your power chair in freewheel mode without an attendant present.

WARNING! Do not attempt to personally place your power chair in freewheel mode while seated on it. Ask an attendant for assistance if necessary.



WARNING! Do not place your power chair in freewheel mode while on an incline or decline. The chair could roll uncontrollably on its own.

Braking Information

Your power chair is equipped with two powerful brake systems:

- Regenerative — uses electricity to rapidly slow the vehicle when the joystick returns to the center/stop position.
- Disc Park Brake — activates mechanically after regenerative braking slows the vehicle to near stop, or when power is removed from the system for any reason.

Cornering Information

While your power chair is equipped with rear caster wheels and front anti-tip wheels, excessively high cornering speeds can still create the possibility of tipping. Factors which affect the possibility of tipping include, but are not limited to: cornering speed, steering angle (how sharply you are turning), uneven road surfaces, inclined road surfaces, riding from an area of low traction to an area of high traction (such as passing from a grassy area to a paved area – especially at high speed while turning), and abrupt directional changes. High cornering speeds are not recommended. If you feel that you may tip over in a corner, reduce your speed and steering angle (i.e., lessen the sharpness of the turn) to prevent your power chair from tipping.



WARNING! When cornering sharply, reduce your speed and maintain a stable center of gravity. This greatly reduces the possibility of a tip or fall.

II. SAFETY

Public Streets and Roadways



WARNING! You should not operate your power chair on public streets and roadways. Be aware that it may be difficult for traffic to see you when you are seated on your power chair. Obey all local pedestrian traffic rules. Wait until your path is clear of traffic, and then proceed with extreme caution.

Outdoor Driving Surfaces

Your power chair is designed to provide optimum stability under normal driving conditions—dry, level surfaces composed of concrete, blacktop, or asphalt. However, Pride recognizes that there will be times when you will encounter other surface types. For this reason, your power chair is designed to perform admirably on packed soil, grass, and gravel. Feel free to use your power chair safely on lawns and in park areas.

- Reduce your power chair's speed when driving on uneven terrain and/or soft surfaces.
- Avoid tall grass that can entangle the running gear.
- Avoid loosely packed gravel and sand.
- If you feel unsure about a driving surface, avoid that surface.

Inclement Weather Precautions

Exposure of your power chair to inclement weather conditions should be avoided whenever possible. If suddenly caught up in rain, snow, severe cold or heat while operating your power chair, proceed to shelter at the earliest opportunity. Thoroughly dry your power chair before storing, charging, or operating your power chair.



PROHIBITED! Operating in rain, snow, salt, mist/spray conditions, and on icy/slippery surfaces can have an adverse effect on the electrical system. Maintain and store your power chair in a dry and clean condition.



WARNING! Prolonged exposure to hot or cold conditions may affect the temperature of upholstered and non-upholstered items on the power chair, possibly resulting in skin irritation. Exercise caution when using your power chair in extremely hot or cold conditions or when exposing your power chair to direct sunlight for prolonged periods of time.

Stationary Obstacles (Steps, Curbs, etc.)

Proceed with extreme caution when driving near raised surfaces, unprotected ledges and/or drop-offs (curbs, porches, stairs, etc.). Be sure your power chair is traveling perpendicular to any curb you may be required to navigate. See figure 2.

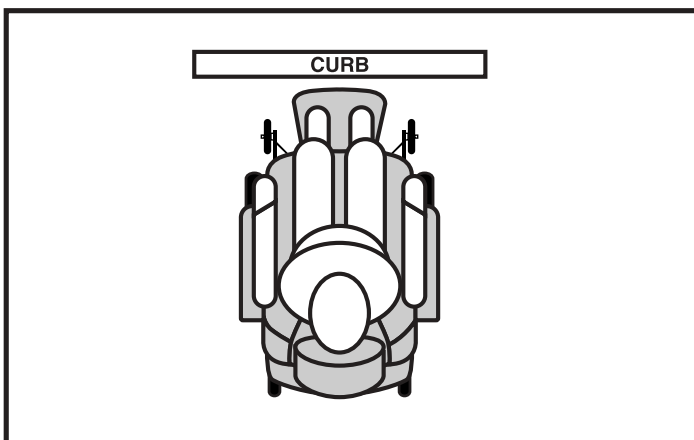

Figure 2. Correct Curb Approach

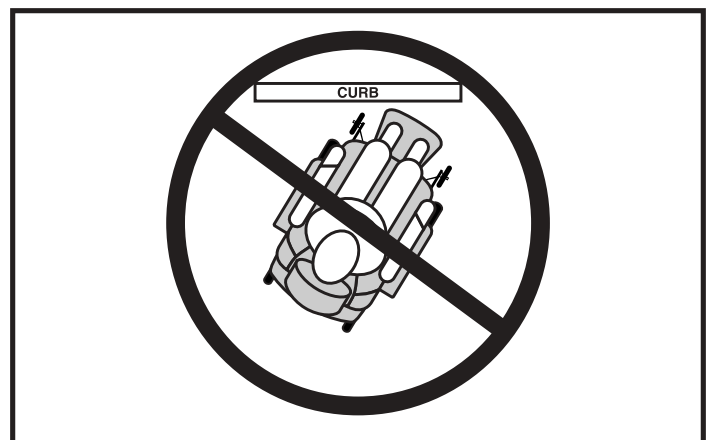

Figure 3. Incorrect Curb Approach

II. SAFETY



WARNING! Do not attempt to have your power chair climb or descend an obstacle that is higher than 2 in. (5 cm) unless you have the assistance of an attendant.

WARNING! Do not attempt to have your power chair proceed backward down any step, curb, or other obstacle. This may cause the power chair to tip.

Stairs and Escalators

Power chairs are not designed to travel up or down stairs or escalators. Always use an elevator.



WARNING! Never use your power chair to negotiate steps or escalators.

Doors

- Determine if the door opens toward or away from you.
- Drive your power chair gently and slowly forward to push the door open. Or drive your power chair gently and slowly backward to pull the door open.

Elevators

Modern elevators have a door edge safety mechanism that, when pushed, reopens the elevator door(s).

- If you are in the doorway of an elevator when the door(s) begin to close, push on the rubber door edge or allow the rubber door edge to contact the power chair and the door will reopen.
- Use care that pocketbooks, packages, or power chair accessories do not become caught in elevator doors.

Lift/Elevation Products

If you will be traveling with your power chair, you may find it necessary to use a lift/elevation product to aid in transportation. Pride recommends that you closely review the instructions, specifications, and safety information set forth by the manufacturer of the lift/elevation product before using that product.



WARNING! Never sit on your power chair when it is being used in connection with any type of lift/elevation product. Your power chair was not designed with such use in mind and any damage or injury incurred from such use is not the responsibility of Pride.

Motor Vehicle Transport

Pride recommends that you do not remain seated in your power chair while traveling in a motor vehicle. The power chair should be stowed in the trunk of a car or in the back of a truck or van with batteries removed and properly secured.

WARNING! Do not sit on your power chair while it is in a moving vehicle.



WARNING! Always be sure your power chair and its batteries are properly secured when it is being transported. Batteries should be secured in a upright position and protective caps should be installed on the battery terminals. Batteries should not be transported with any flammable or combustible items.

Positioning Belts

Your Quantum Rehab Specialist, therapist(s), and other healthcare professionals are responsible for determining your requirement for a positioning belt in order to operate your power chair safely.



WARNING! If you require a positioning belt to safely operate your power chair, make sure it is fastened securely in order to reduce the possibility of a fall from the power chair.

WARNING! The positioning belt is not designed for use as a seat belt in a motor vehicle. Nor is your power chair suitable for use as a seat in any vehicle. Anyone traveling in a vehicle should be properly belted into seats approved by the vehicle manufacturer.

II. SAFETY

Batteries

In addition to following the warnings below, be sure to comply with all other battery handling information. For more information about your power chair's batteries, see VII. "Batteries and Charging."



MANDATORY! Battery posts, terminals, and related accessories contain lead and lead compounds. Wear goggles and gloves when handling batteries and wash hands after handling.

WARNING! Power chair batteries are heavy. See specifications table. If you are unable to lift that much weight, be sure to get help. Use proper lifting techniques and avoid lifting beyond your capacity.



WARNING! Always protect the batteries from freezing and never charge a frozen battery. Charging a frozen battery may result in damage to the battery.

WARNING! Connect your battery harnesses in the proper manner. RED (+) cables must be connected to positive (+) battery terminals/posts. BLACK (-) cables must be connected to negative (-) battery terminals/posts. Protective caps should be installed over all battery terminals. **REPLACE** cables immediately if damaged.

Removable Parts



WARNING! Do not attempt to lift or move a power chair by any of its removable parts, including the armrests, seat, foot riggings, controller, and shrouds.

Preventing Unintended Movement



WARNING! If you anticipate being seated in a stationary position for an extended period of time, turn off the power. This will prevent unexpected motion from inadvertent joystick contact. This will also eliminate the possibility of unintended chair movement from electromagnetic (EM) sources.

Reaching and Bending

Never reach, lean, or bend while driving your power chair. If it is absolutely necessary to reach, lean, or bend while seated on your power chair, it is important to maintain a stable center of gravity and keep the power chair from tipping. Pride recommends that the power chair user determine his/her personal limitations and practice bending and reaching in the presence of a qualified healthcare professional.



WARNING! Do not bend, lean, or reach for objects if you have to pick them up from the floor by reaching down between your knees or if you have to reach over the back of the seat. Movements such as these may change your center of gravity and the weight distribution of the power chair. This may cause your power chair to tip.



WARNING! Keep your hands away from the tires when driving. Be aware that loose fitting clothing can become caught in drive tires.

II. SAFETY

Transfers

Transferring onto and off of your power chair requires a good sense of balance. Always have an attendant or health-care professional present while learning to properly transfer yourself.

To eliminate the possibility of injury, Pride recommends that you or a trained attendant perform the following tasks before attempting a transfer:

- Turn off the power to the controller.
- Ensure your power chair is not in freewheel mode. See III. “Your Power Chair.”
- Turn the caster wheels toward the transfer destination to improve power chair stability during transfer.
- Make sure both armrests are flipped up or removed from your power chair.
- Flip up the foot platform or move the leg rests aside; this will help to keep your feet from getting caught on the foot rigging during the transfer.
- Reduce the distance between your power chair and the object you are transferring onto.

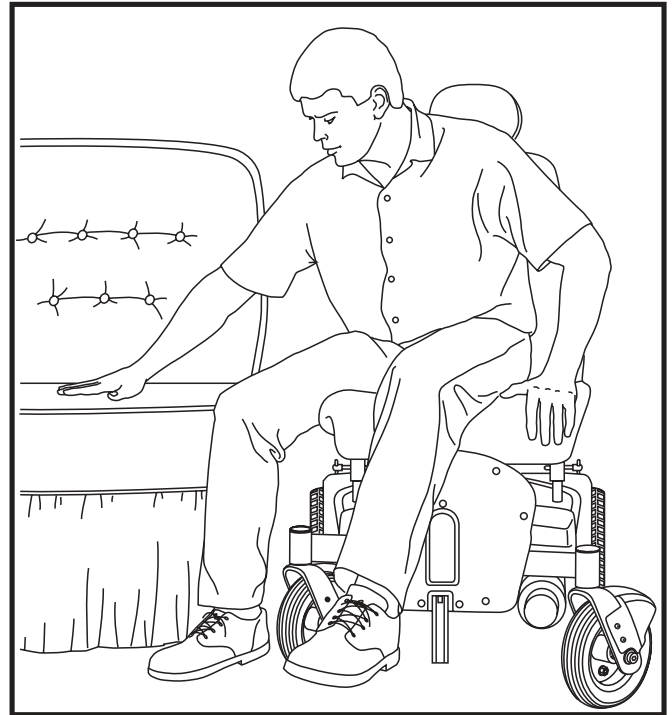

Figure 4. Ideal Transfer Position

WARNING! Before transferring, position yourself as far back as possible in the power chair seat to prevent the power chair from tipping forward during transfer.



WARNING! Avoid putting all of your weight on the power chair armrests and do not use the armrests for weight bearing purposes, such as transfers. Such use may cause the power chair to tip, resulting in a fall from the power chair and personal injury.

WARNING! Avoid putting all of your weight on the foot riggings. Such use may cause the power chair to tip.

Prescription Drugs/Physical Limitations

Users must exercise care and common sense when operating a power chair. This includes awareness of safety issues when taking prescribed or over-the-counter drugs or when the user has specific physical limitations.



WARNING! Consult your physician if you are taking prescribed or over-the-counter medication or if you have certain physical limitations. Some medications and limitations may impair your ability to operate your power chair in a safe manner.

Alcohol/Smoking

The power chair user must exercise care and common sense when operating his/her power chair. This includes awareness of safety issues while under the influence of alcohol or while smoking.



WARNING! Do not operate your power chair while you are under the influence of alcohol, as this may impair your ability to operate your power chair in a safe manner.

II. SAFETY

WARNING! Pride strongly recommends that you do not smoke cigarettes while seated in your power chair, although the power chair has passed the necessary testing requirements for cigarette smoking. You must adhere to the following safety guidelines if you decide to smoke cigarettes while seated in your power chair.



- Do not leave lit cigarettes unattended.
- Keep ashtrays a safe distance from the seat cushions.
- Always make sure cigarettes are completely extinguished before disposal.

Electromagnetic and Radio Frequency Interference (EMI/RFI)



WARNING! Laboratory tests have shown that electromagnetic and radio frequency waves can have an adverse affect on the performance of electrically-powered mobility vehicles.

Electromagnetic and Radio Frequency Interference can come from sources such as cellular phones, mobile two-way radios (such as walkie-talkies), radio stations, TV stations, amateur radio (HAM) transmitters, wireless computer links, microwave signals, paging transmitters, and medium-range mobile transceivers used by emergency vehicles. In some cases, these waves can cause unintended movement or damage to the control system. Every electrically-powered mobility vehicle has an immunity (or resistance) to EMI. The higher the immunity level, the greater the protection against EMI. This product has been tested and has passed at an immunity level of 20 V/m.



WARNING! Be aware that cell phones, two-way radios, laptops, and other types of radio transmitters may cause unintended movement of your electrically-powered mobility vehicle due to EMI. Exercise caution when using any of these items while operating your mobility vehicle and avoid coming into close proximity of radio and TV stations.



WARNING! The addition of accessories or components to the electrically-powered mobility vehicle can increase the susceptibility of the vehicle to EMI. Do not modify your power chair in any way not authorized by Pride.

WARNING! The electrically-powered mobility vehicle itself can disturb the performance of other electrical devices located nearby, such as alarm systems.

NOTE: For further information on EMI/RFI, go to the Resource Center on www.pridemobility.com. If unintended motion or brake release occurs, turn your power chair off as soon as it is safe to do so. Call Pride at 800-424-8205 to report the incident.

III. YOUR POWER CHAIR

THE QUANTUM 1402 POWER CHAIR

Your power chair has two main assemblies: the seat and the power base. Typically, the seating assembly includes the armrests, seatback, and controller. The power base assembly includes two drive wheels, two anti-tip wheels, two rear caster wheels, a power seat connector (optional), harness connectors, and a body shroud. See figures 5 and 6.



Figure 5. The Quantum 1402 Power Chair

III. YOUR POWER CHAIR

Electronics Tray

The electronics tray is located on the rear of your power chair. The electronics tray is located underneath the rear sliding door and consists of the ammeter, the charger power cord receptacle, the main circuit breaker, accessory connector (optional equipment), and the controller connectors(s). See figure 6.

Ammeter: The ammeter displays the charger’s current output in amps. For more information, see VII. “Batteries and Charging” in this manual.

Charger Power Cord Receptacle: This receptacle is used whenever the batteries need recharging.

Main Circuit Breaker: The main circuit breaker is a safety feature built into your power chair. When the batteries and the motors are heavily strained (e.g., from excessive loads), the main circuit breaker trips to prevent damage to the motors and the electronics. If the circuit trips, allow your power chair to “rest” for approximately one minute. Next, push in the circuit breaker button, turn on the controller, and continue normal operation. If the main circuit breaker continues to trip repeatedly, contact your authorized Quantum Rehab Specialist.

Accessory Connector (Optional): This is where the optional power harness connects to the controller.

Controller Connector(s): This is where the controller connects to the power base. Each controller uses a different type of cable. Regardless of which type of controller is used, the cable must be secured to the seat assembly and not allowed to drag on the floor.

Power Seat Connector (Optional): This is for the optional power seat switch.

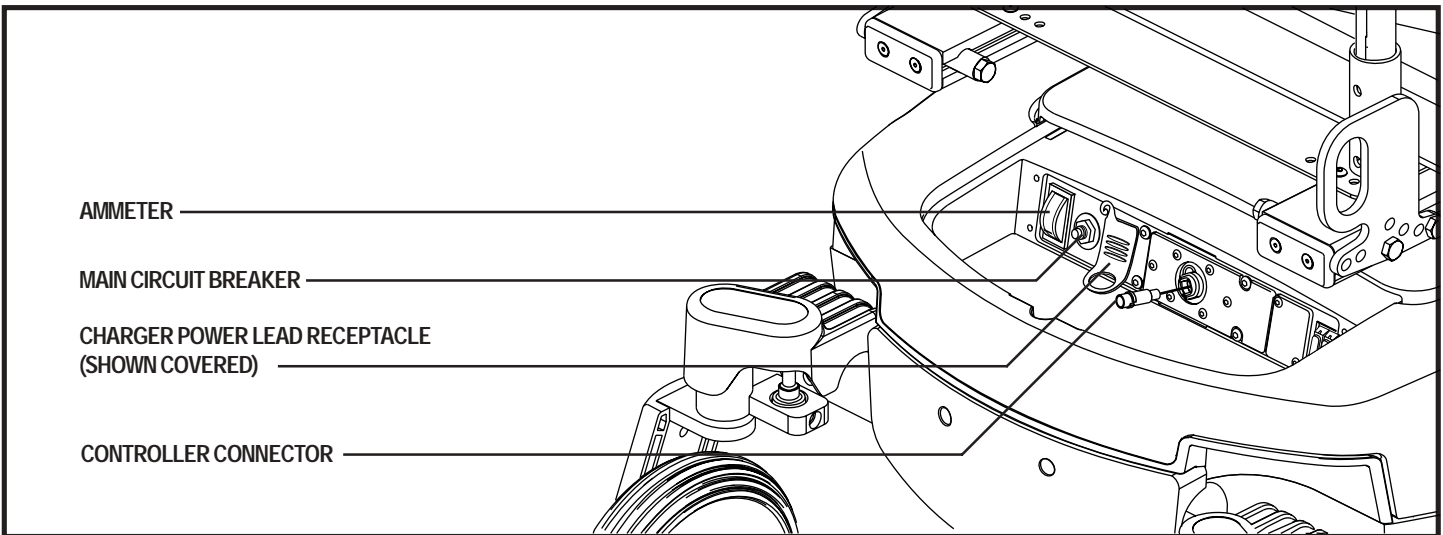

Figure 6. Electronics Tray

III. YOUR POWER CHAIR

Dual Manual Freewheel Levers

For your convenience, your power chair is equipped with dual manual freewheel levers. The levers are located on the inside of the anti-tip wheels. The levers allow you to disengage the drive motors and maneuver the chair manually.



WARNING! Do not use the power chair while the drive motors are disengaged! Do not disengage the drive motors when the power chair is on an incline, as the unit could roll on its own! Only engage the freewheel mode when on a level surface.

WARNING! It is important to remember that when your power chair is in freewheel mode, the braking system is disengaged.

To operate the dual manual freewheel levers:

1. Pull both levers upward to disengage the drive motors (freewheel mode). See figure 7.
2. Push both levers downward to engage the drive motors (drive mode). See figure 8.

If a lever is difficult to move in either direction, rock your power chair back and forth slightly. The lever should then move to the desired position.



WARNING! Do not use the freewheel lever handles as tie-down points to secure this product.

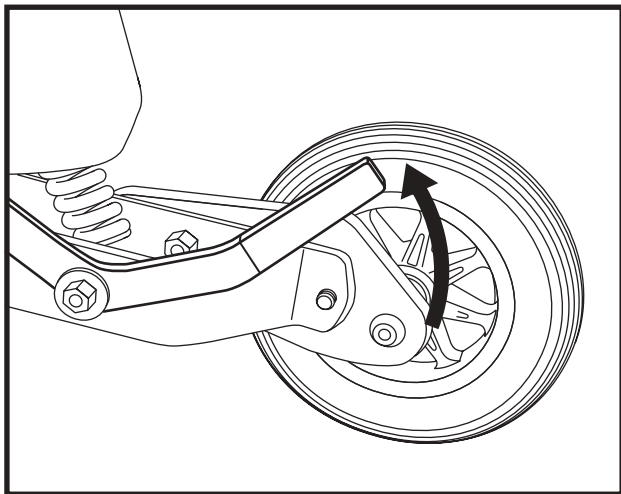

Figure 7. Freewheel Mode (left side shown)

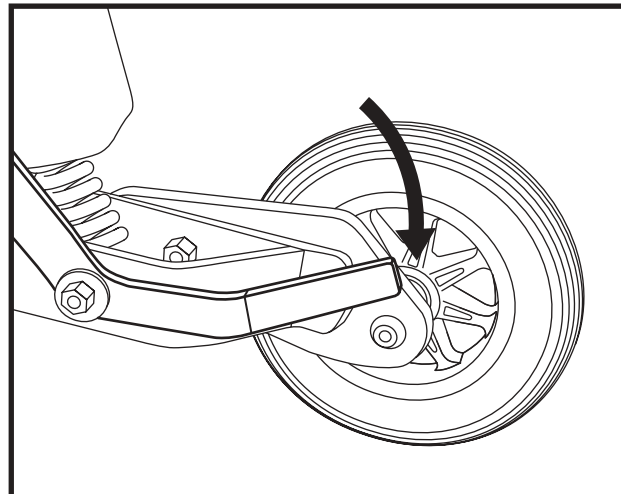

Figure 8. Drive Mode (left side shown)

Active-Trac Suspension

Your power chair is equipped with Active-Trac Suspension (ATS). ATS is a suspension system designed to make your power chair traverse different types of terrain and obstacles while maintaining smooth operation. With ATS, the front anti-tip wheels work in conjunction with the motor suspension to help you maneuver over obstacles.

As the front anti-tip wheels come in contact with an obstacle, the front anti-tip wheel assembly is drawn upward. At the same time, the motors are forced downward. This allows the motors to push the power chair over an obstacle and limits the possibility of your power chair getting caught on the obstacle.

ATS also helps in day-to-day operating conditions. For instance, when you release the joystick your power chair begins to slow down. As the chair slows down, the front anti-tip wheels will automatically drop toward the ground. This will reduce the forward tip that is typically encountered with mid-wheel drive chairs.

III. YOUR POWER CHAIR

Rear Suspension

Your power chair is equipped with rear suspension. See figure 9. This suspension system works in conjunction with ATS and is designed to maintain a smooth ride when driving over rough terrain and up and down curbs. This system works by allowing the caster forks to respond to weight transfers and uneven terrain. The rear caster wheels will pivot as you drive over obstacles. This system also enhances performance when the front anti-tip wheels are set lower to the surface.

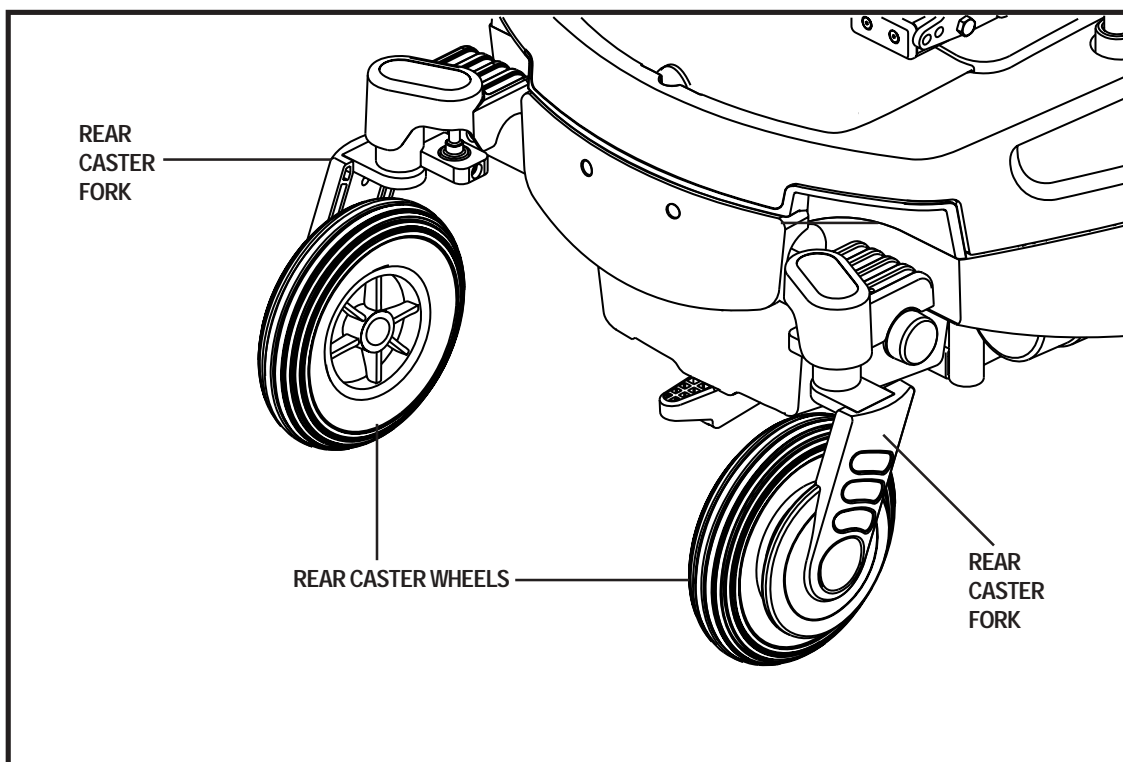

Figure 9. Rear Suspension System

IV. ASSEMBLY

INITIAL ASSEMBLY

Your power chair may require some assembly either before initial use or after transportation.

NOTE: Any nylon insert lock nut removed during the disassembly or adjustment of the power chair must be replaced with a new nut. Nylon insert lock nuts should not be reused as it may cause damage to the nylon insert, resulting in a less secure fit. Replacement nylon insert lock nuts are available at local hardware stores or through your Quantum Rehab Specialist.

Seat Installation

Most seats are attached to the power base with the Universal Mounting System (UMS). The UMS consists of universal parts that may be attached to any medium-back or high-back seat, regardless of seat width or seat depth. The two main components are aluminum extrusions mounted to the seat base. These extrusions attach to a pair of trapeze bars that are mounted to the power base. See figure 10.

NOTE: If your power chair is equipped with a Specialty Seat, Synergy Seat, or TRU-Balance Power Positioning System, refer to the information provided in separate manuals.



WARNING! Do not pick up the seat frame by the armrests. They are free to pivot, and you may lose control of the seat if they do so.

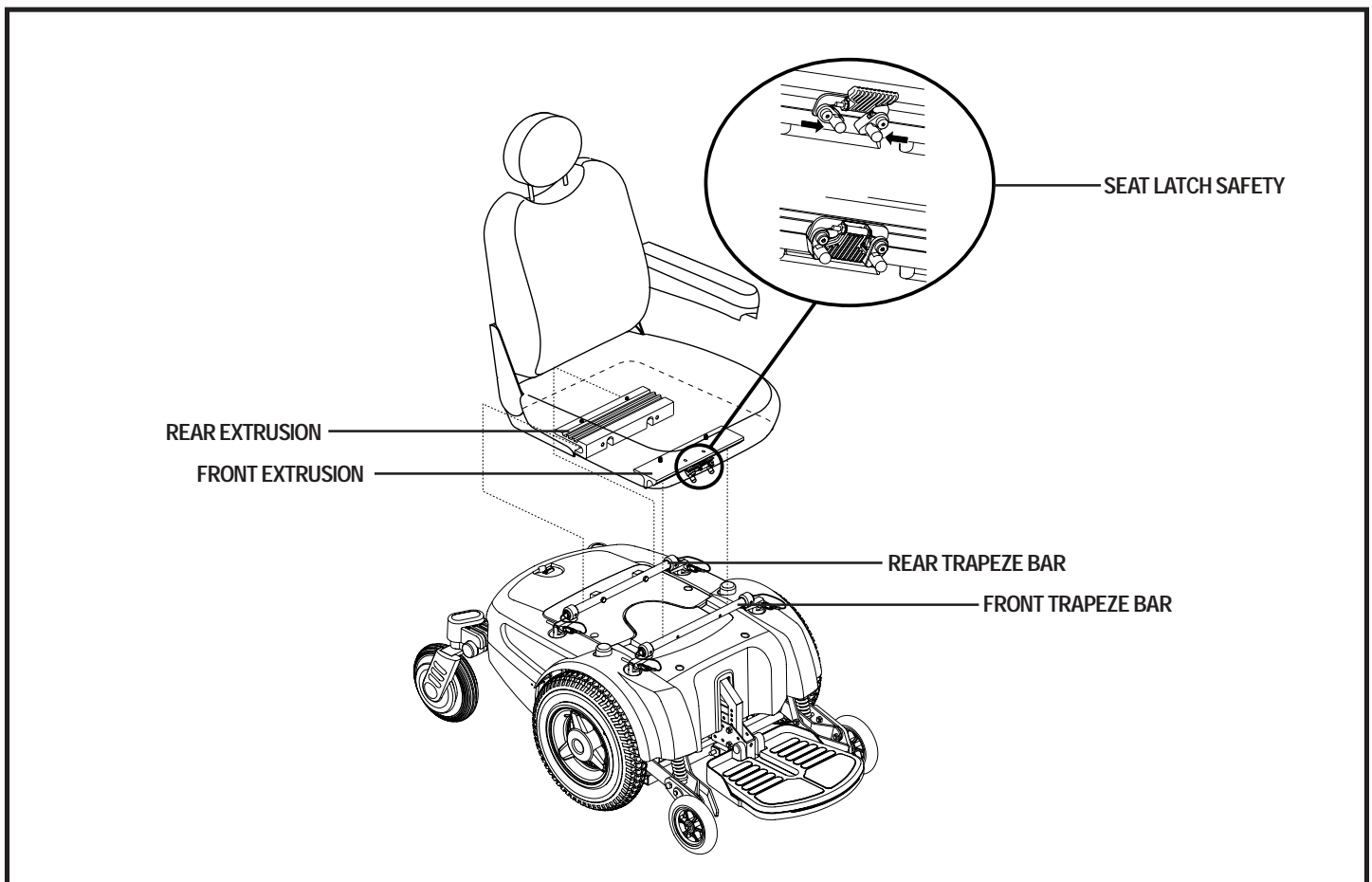

Figure 10. Seat Installation

IV. ASSEMBLY

To install the seat:

1. Set the trapeze bars to the desired height. To change the trapeze bar height, see V. “Comfort Adjustments.”
2. Tilt the seat back and slide the rear extrusion onto the rear trapeze bar. See figure 10.
3. Lower the front extrusion onto the front trapeze bar until the seat locks into place.
4. Flip the seat latch safety down.



WARNING! Make sure the seat latch safety is flipped down before using your power chair.

5. Install the controller into one of the armrests. See V. “Comfort Adjustments.”
6. Route the controller cable to the rear of the power base.



WARNING! Do not place the controller cable so that it can be pinched in the seat frame or power base frame.

7. Slide the rear cover open to expose the electronics tray.
8. Plug the controller connector into the electronics tray. See figure 6.
9. Secure the controller cable to the armrest receiver with one or more wire ties.

Power Seat Option Installation

Your power chair may be equipped with the power seat option. While the seat itself may be any one of the styles offered for this model, the way the seat base attaches to the Quantum 1402 power base is different.

To install the power seat:

1. Align the seat post on the seat base to the hole in the actuator. See figure 11.
2. Insert the seat post into the actuator and push the seat lever forward.
3. Lock the seat into place.

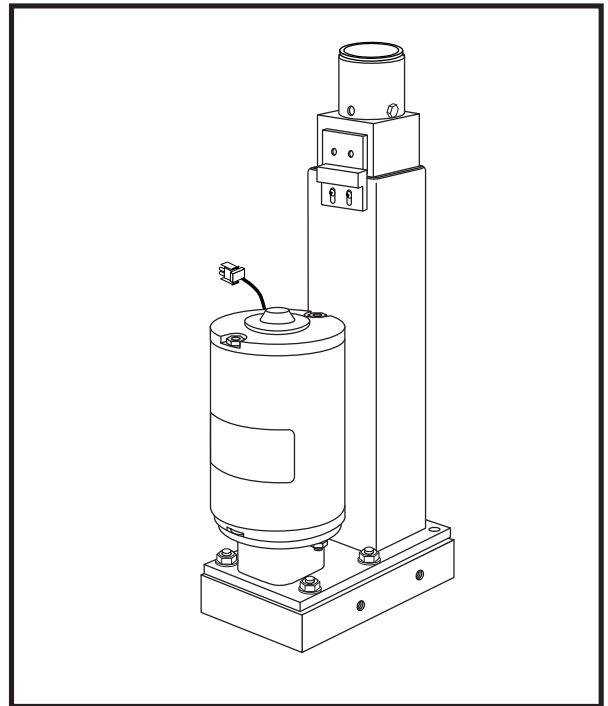

Figure 11. Power Seat Actuator

V. COMFORT ADJUSTMENTS

COMFORT ADJUSTMENTS

After becoming familiar with your power chair's operation, you may find the need to make some adjustments to increase your comfort, such as seat height and angle, armrest angle, foot platform height and angle, and the controller's position.

NOTE: *If your power chair is equipped with a Specialty Seat, Synergy Seat, or Synergy TRU-Balance, refer to the information provided in separate manuals. If your power chair is equipped with a contoured seating system, refer to the following information.*

WARNING! If your power chair was configured at your Quantum Rehab Specialist, please consult your healthcare professional before changing the seat position or making any other adjustment. Some adjustments may degrade your power chair's performance and safety by changing its center of gravity.



WARNING! Some power chair components are heavy. You may need assistance to lift or carry them. Please refer to the specifications table for specific component weights before you disassemble the power chair.

WARNING! Remove the occupant from the power chair before making any adjustments.

You may need the following to make comfort adjustments:

- metric/standard hex key set
- metric/standard socket set and ratchet
- adjustable wrench

Seat Height/Angle Adjustment

The seat is attached to the power base through the UMS. You can change the seat height by raising the front and rear trapeze bars. If you raise or lower only one set of trapeze bars (front or rear), you can also change the seat base angle (dump).

To change the seat height:

1. Turn off the power to the controller.
2. Unplug the controller connector(s) from the electronics tray.
3. Flip up the seat latch safety. See figure 12.
4. Squeeze the seat latch and release the seat from the front trapeze bar.
5. Slide the seat forward and remove it from the power base.
6. Remove the quick-release pins from the seat towers (front and rear). See figure 13.
7. Remove both trapeze bars from the seat towers.
8. Lift off the shroud
9. Remove the ball detent pin from each of the four seat towers. See figure 13.

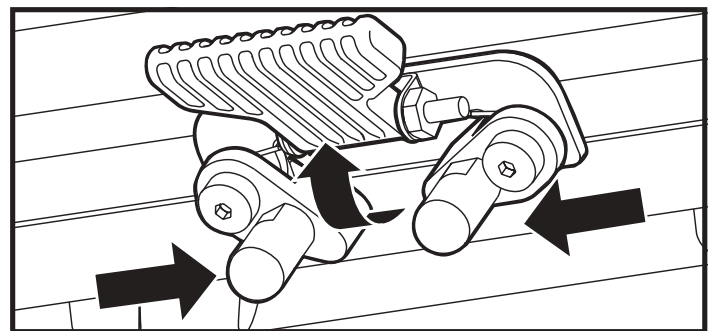

Figure 12. Seat Latch Safety (Disengaged)

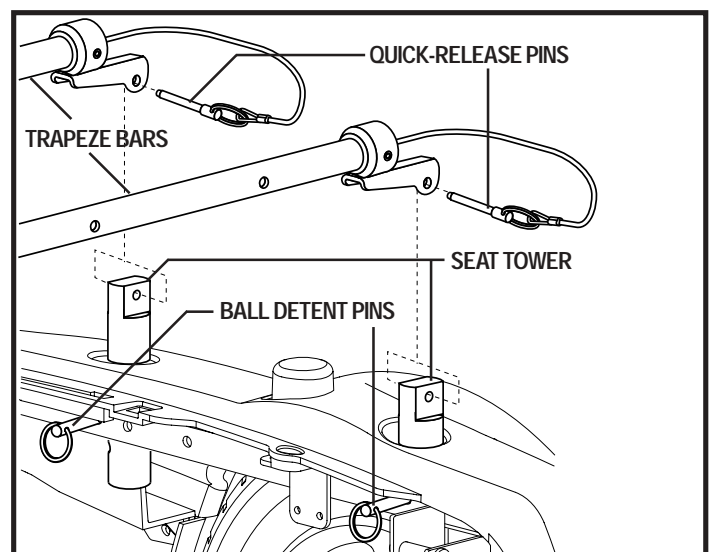

Figure 13. Seat Height Adjustment

V. COMFORT ADJUSTMENTS

10. Move the seat towers up or down to the desired height.
11. Reinstall the ball detent pin into each seat tower.
12. Reinstall the shroud.
13. Reinstall the trapeze bars and secure with the quick-release pins.
14. Reinstall the seat.



WARNING! Make sure the seat latch safety is flipped down before using the power chair.

15. Plug the controller connector(s) into the electronics tray.

Seat Position

You can move the seat forward or rearward by changing the extrusion mounting position.

To change the seat position:

1. Turn off the power to the controller.
2. Unplug the controller connector(s) from the electronics tray.
3. Remove the seat from the power base.
4. Remove both extrusions from the bottom of the seat.
5. Reposition the extrusions on a different set of mounting holes. You must move both extrusions the same number of holes either forward or backwards. See figure 14.
6. Fasten the extrusions back onto the bottom of the seat.
7. Reinstall the seat.
8. Plug the controller connector(s) into the electronics tray.

Manual Recline Seatback Adjustment

If your power chair is equipped with a reclining seat, you can adjust the seatback angle with the seatback release lever. This lever is located on the right side of the seat base.

To adjust the seatback angle:

1. Pull up on the seatback release lever.
2. Lean forward or backwards to the desired position.
3. Release the lever.

Seatback Angle Adjustment

If your power chair is equipped with an adjustable seatback, you can adjust it to four (4) different angles: 90°, 102°, 105°, or 107°.

To adjust the seatback angle:

1. Remove the seatback angle adjusting screws from both seat hinges. See figure 15.
2. Set the seatback at the desired angle.
3. Reinstall the screws on both seat hinges and retighten.

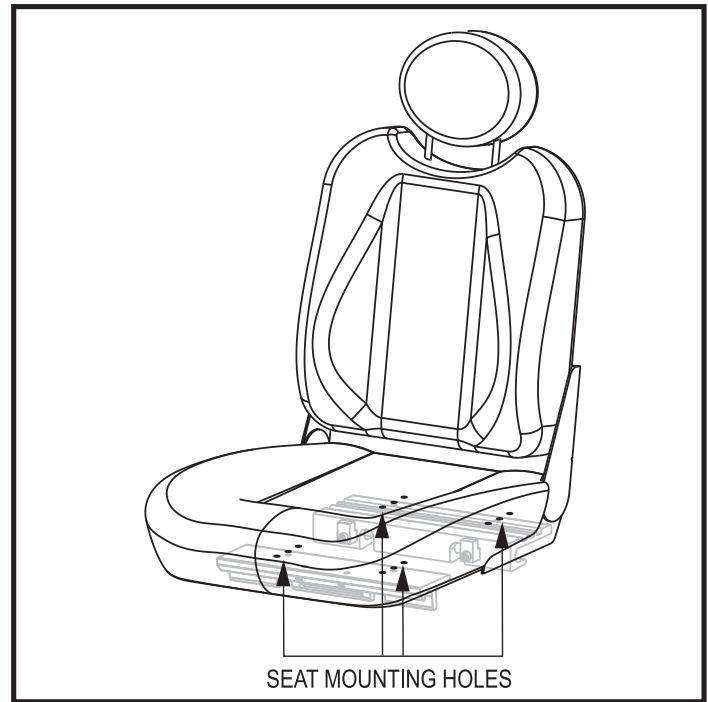

Figure 14. Seat Position Adjustment

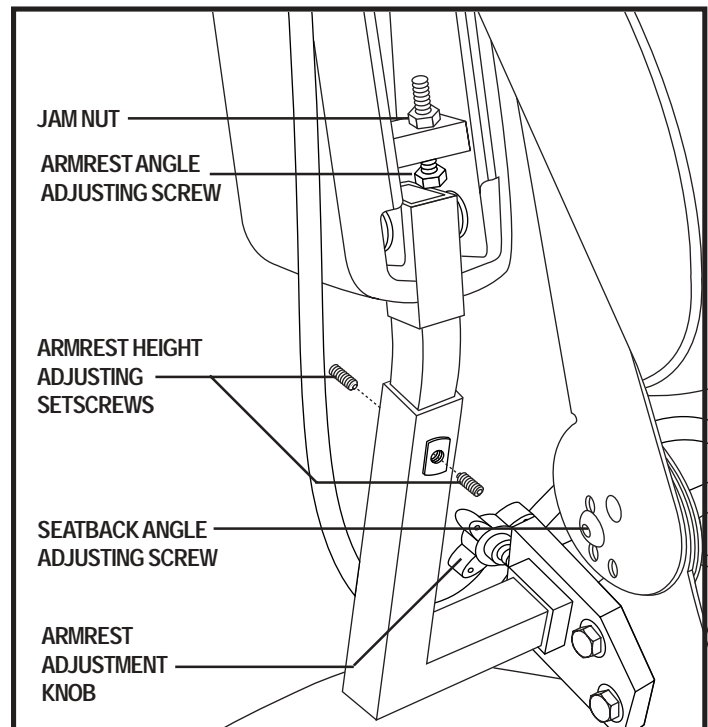

Figure 15. Seatback and Armrest Adjustments

V. COMFORT ADJUSTMENTS

Armrest Width Adjustment

You can change each armrest's width independently of the other.

To change the armrest width:

1. Locate the two adjustment knobs on the armrest receiver bracket.
See figure 15.
2. Loosen the knobs.
3. Slide the armrests in or out to the desired width.
4. Tighten the knobs.

Armrest Angle Adjustment

To change the armrest angle:

1. Lift the armrest straight up so that it is perpendicular to the floor. See figure 15.
2. Loosen the jam nut.
3. Turn the adjusting screw to raise or lower the front of the armrest.
4. Tighten the jam nut to lock the adjusting screw into place.

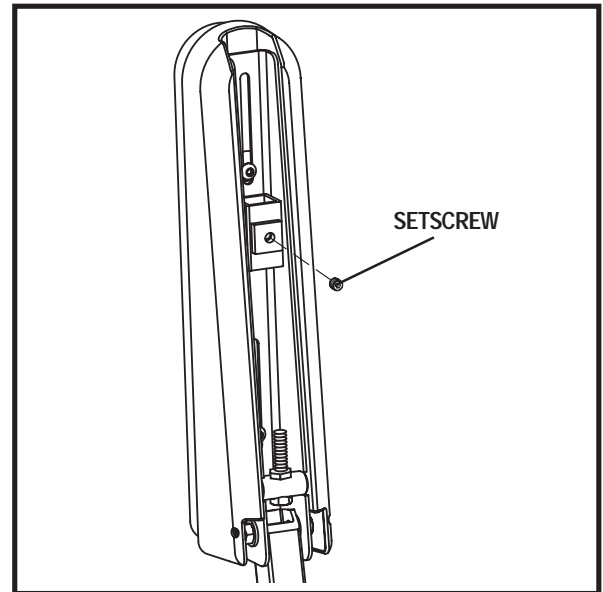

Figure 16. Underside of Armrest

Armrest Height Adjustment

To change the armrest height:

1. Loosen the two setscrews located on the armrest receiver. See figure 15.
2. Raise or lower the armrest to the desired height.
3. Tighten the setscrews to secure the armrest.

Controller Position

You can move the controller in toward or out away from the armrest, or change the position of the controller for either left-hand or right-hand use.



MANDATORY! Prevent controller harness damage! Avoid routing the controller harness on the outside of the armrest pad. Route the harness under the armrest or toward the inside of the armrest pad. Use correct tie-down points for the controller harness to prevent the harness from getting caught in the drive tires, pinched in the seat frame, or damaged when passing through doorways.

To extend the controller:

1. Flip up the armrest so it is perpendicular to the floor.
2. Loosen the setscrew on the controller bracket. See figure 16.
3. Slide the controller into or out of the armrest to the desired position.
4. Tighten the setscrew to secure the controller.

To change the controller position:

1. Unplug the controller connector from the electronics tray. See figure 6.
2. Cut the wire tie that attaches the controller cable to the armrest.
3. Flip up the armrest so that it is perpendicular to the floor.
4. Loosen the setscrew under the armrest. See figure 16.
5. Slide the controller out of the armrest.
6. Loosen the setscrew under the other armrest.

7. Place the controller in the other armrest.
8. Tighten the setscrew.
9. Use a wire tie to secure the controller cable to the armrest.
10. Plug the controller connector into the electronics tray.

NOTE: *If your power chair is equipped with a Specialty Seat, Synergy Seat, or a TRU-Balance Power Positioning System, refer to the information provided in separate manuals.*

Foot Platform Height Adjustment

The foot platform height is easily adjusted to one of six different heights in 1-in. (2.54 cm) increments.

To raise or lower the foot platform:

1. Remove the nuts and bolts from the foot platform bracket. See figure 17.
2. Raise or lower the foot platform to the desired height.
3. Reinstall the bolts and nuts into the foot platform bracket and retighten.

Foot Platform Depth Adjustment

To adjust the foot platform depth:

1. Remove the nuts and bolts from the foot platform bracket. See figure 17.
2. Move the foot platform in or out to the desired depth.
3. Reinstall the nuts and bolts into the foot platform bracket and retighten.

Foot Platform Angle Adjustment

You can adjust the angle of the foot platform with a hex key. See figure 18.

To adjust the foot platform angle:

1. Locate the setscrew on the underside of the foot platform.
2. Turn the setscrew to raise or lower the front of the foot platform.

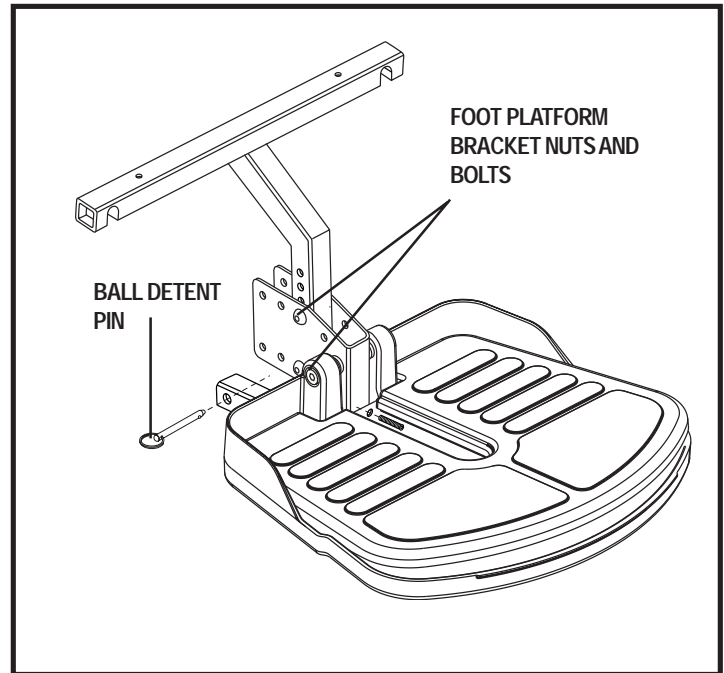

Figure 17. Foot Platform Height/Depth Adjustment

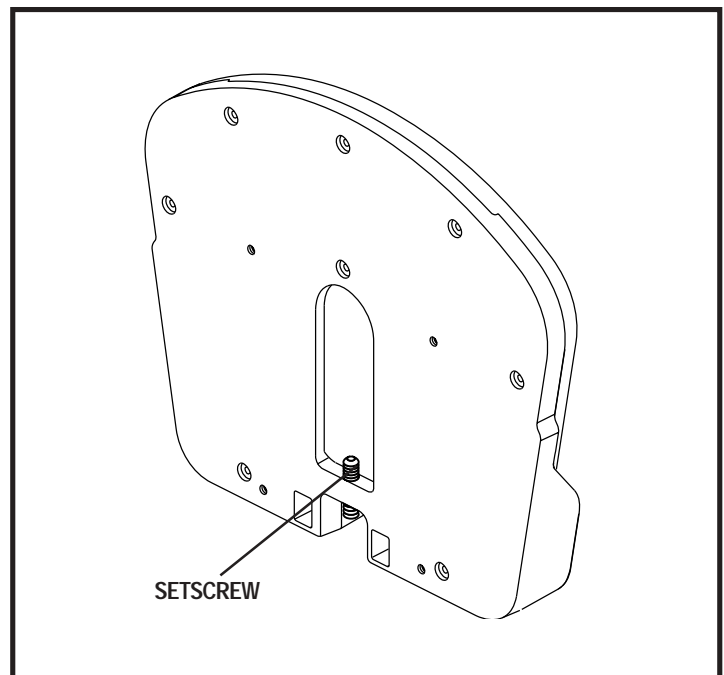

Figure 18. Foot Platform Angle Adjustment

Power Elevating Seat Option

If your power chair is equipped with a power elevating seat, you can change the seat height automatically. The power elevating seat is operated through a switch located on one of the armrests or on the controller.

To change the seat height using the power elevating seat switch on the armrest:

1. Press forward on the power elevating seat switch to raise the seat. See figure 19.
2. Pull back on the power elevating seat switch to lower the seat

WARNING! Do not allow the motor to run more than a few seconds after the mechanism reaches the top or bottom limit.

WARNING! The power elevating seat option is intended for use on a level surface only. Never raise the seat from its lowest position on an inclined surface. Failure to heed this warning can result in the power chair tipping over.



WARNING! Never raise the seat from its lowest position when operating your power chair on bumpy or uneven surfaces. Failure to heed this warning can result in the power chair tipping over.

WARNING! Never raise the power elevating seat while your power chair is in freewheel mode.

WARNING! Always fasten the positioning belt when operating the power elevating seat.

NOTE: *The power elevating seat option is equipped with a system that reduces the speed of the power chair by one half when the seat is elevated more than 1–2 inches (2.5–5 cm). Always check to be sure this system is operating properly before using your power chair.*

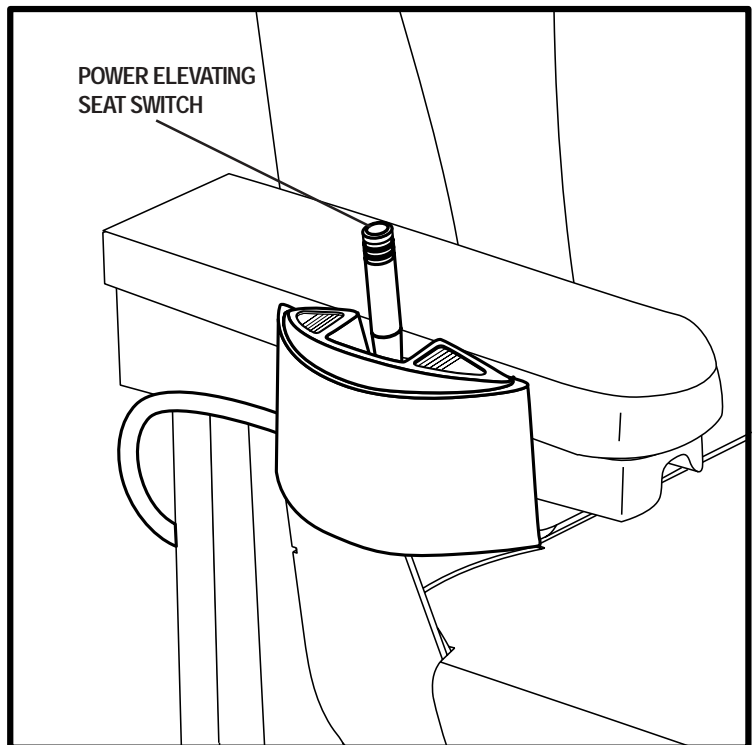

Figure 19. Power Seat Switch

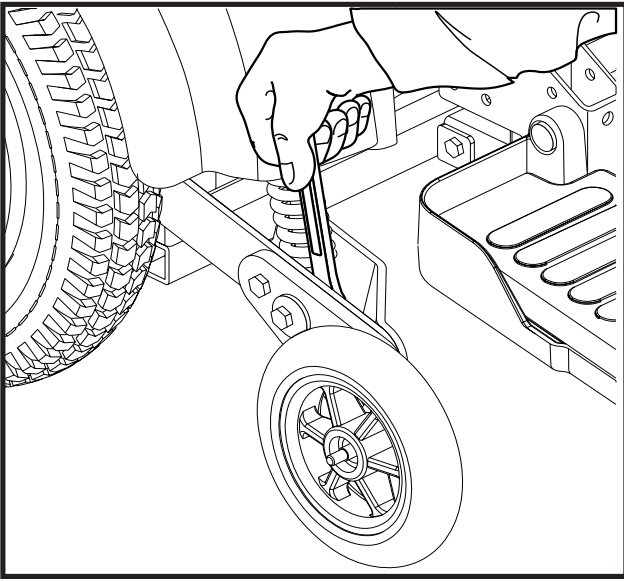

Figure 20. Anti-Tip Bracket (Inner Locknut)

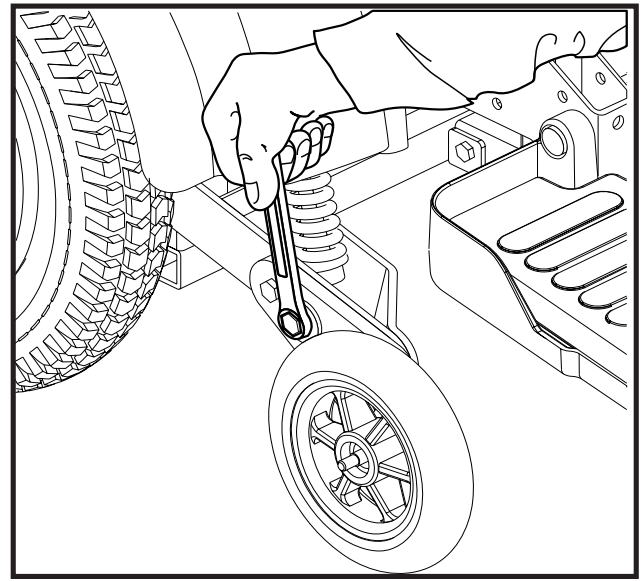

Figure 21. Anti-Tip Wheel Adjustment (Cam)

Anti-tip Wheel Adjustment

The anti-tip wheels are designed to give your power chair increased stability on rough surfaces. The anti-tip wheels are preset at the factory for smooth surfaces or indoor use only. If you plan on using your power chair on rough surfaces, it may be necessary to adjust the anti-tip wheels to better suit your needs. The anti-tip wheels may need adjustment if either of the following occur:

- When coming to a stop, your power chair tips forward excessively.
- The anti-tip wheels constantly rub the ground.

NOTE: Each drive tire must be inflated to 35 psi (2.4 bar) in order for the anti-tip wheels to be properly adjusted.

To adjust the anti-tip wheels:

1. Place an adjustable wrench on the inner locknut of the anti-tip bracket located right after the shock strut. See figure 20.
2. Turn the locknut counterclockwise to loosen.
3. Place your wrench on the adjustable cam located on the other side of the locknut. See figure 21.
4. To adjust the anti-tip upward, turn the cam counterclockwise. To adjust the anti-tip downward, turn the cam clockwise.
5. Tighten the locknut.
6. Make the same adjustment to the other anti-tip wheel.

WARNING! Consult your Quantum Rehab Specialist before attempting to change the anti-tip height! Changing the anti-tip wheel height affects handling under deceleration!



WARNING! The higher you raise the anti-tip wheels, the more tendency your power chair has to tilt forward when coming to a stop. You can compensate for this by making a small adjustment to the pre-programmed deceleration setting in the controller or by moving the seat assembly farther to the rear of your power chair.



PROHIBITED! Do not remove the anti-tip wheels.

VI. DISASSEMBLY

Seat Removal

You may wish to remove the seat for transportation.

NOTE: *If your power chair is equipped with a Specialty Seat, Synergy Seat, or TRU-Balance Power Positioning System, refer to the information provided in separate manuals.*

To remove the seat:

1. Turn off the power to the controller.
2. Make sure your power chair is not in freewheel mode. See III. “Your Power Chair.”
3. Unplug the controller connector from the electronics tray.
4. Flip up the seat latch safety. See figure 22.
5. Squeeze the seat latch and release the seat from the front trapeze bar.
6. Slide the seat forward and remove it from the power base.

To remove a power seat:

1. Turn off the power to the controller.
2. Disconnect the controller from the electronics tray.
3. Release the seat by moving the seat release lever backward.
4. Lift up the power seat plate.
5. Lift the seat off of the actuator.

Foot Platform Removal

The foot platform helps protect your power chair components from the environment. See figure 23. You must remove the foot platform in order to change the batteries and check the cable connections.

To remove the foot platform:

1. Turn off the power to the controller.
2. Make sure your power chair is not in freewheel mode. See III. “Your Power Chair.”
3. Remove the ball detent pin at the base of the foot platform bracket.
4. Lift the foot platform straight up approximately 2 in. (5 cm) and pull it away from the power base.

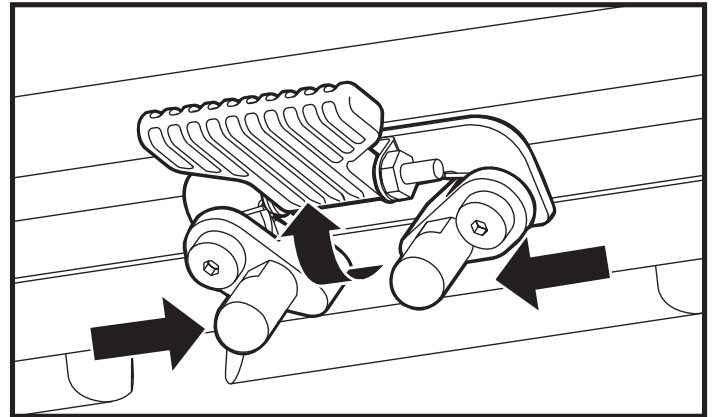

Figure 22. Seat Safety Latch

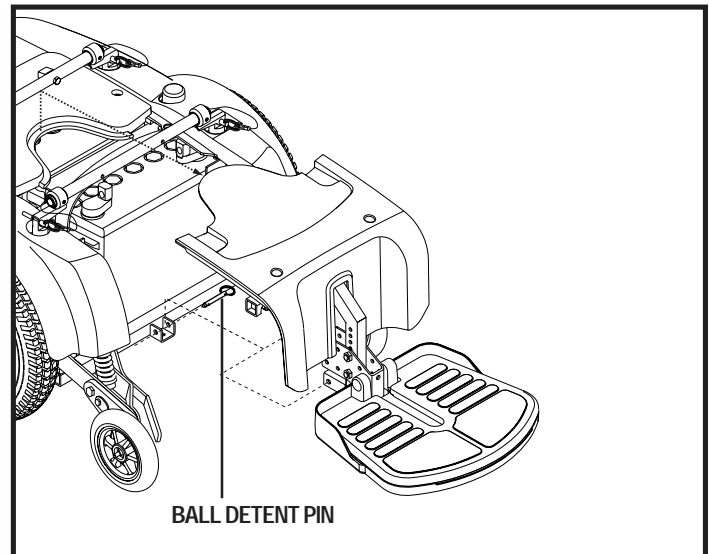

Figure 23. Foot Frame Removal

VII. BATTERIES AND CHARGING

BATTERIES AND CHARGING

Your power chair uses two long-lasting, 12-volt, deep-cycle batteries. These batteries are sealed and maintenance free. Since they are sealed, there is no need to check the electrolyte (fluid) level. Deep-cycle batteries are designed to handle a longer and deeper discharge. Though they are similar in appearance to automotive batteries, they are not interchangeable. Automotive batteries are not designed to handle a long, deep discharge, and also are unsafe for use in powered wheelchairs.



MANDATORY! Battery posts, terminals, and related accessories contain lead and lead compounds. Wear goggles and gloves when handling batteries and wash hands after handling.



WARNING! Always use two batteries of the exact same type, chemistry, and amp-hour (Ah) capacity. Refer to the specifications table in this manual and in the manual supplied with the battery charger for recommended type and capacities.



WARNING! Contact your Quantum Rehab Specialist if you have any questions regarding the batteries in your power chair.

Charging The Batteries

The battery charger is essential in providing long life for your power chair batteries. The battery charger is designed to optimize your power chair's performance by charging the batteries safely, quickly, and easily. If your power chair is equipped with an onboard battery charger, the charging system consists of the battery charger, the charger fuse, and the ammeter. The onboard charger is located underneath the electronics tray. The ammeter and charger fuse are located on the electronics tray for easy viewing. See figure 6. The ammeter indicates the rate of charge being administered to fully recharge the batteries. It is also a good indication of whether or not the charger is working. The ammeter and the charger are only functional when the charger power cord is plugged into an electrical outlet.



PROHIBITED! Removal of grounding prong can create electrical hazard. If necessary, properly install an approved 3-pronged adapter to an electrical outlet having 2-pronged plug access.



PROHIBITED! Never use an extension cord to plug in your battery charger. Plug the charger directly into a properly wired standard electrical outlet.



PROHIBITED! Do not allow unsupervised children to play near the power chair while the batteries are charging. Pride recommends that you do not charge the batteries while the power chair is occupied.



MANDATORY! Read the battery charging instructions in this manual and in the manual supplied with the battery charger before charging the batteries.



WARNING! Explosive gases may be generated while charging the batteries. Keep the power chair and battery charger away from sources of ignition such as flames or sparks and provide adequate ventilation when charging the batteries.

WARNING! You must recharge your power chair's batteries with the supplied onboard or optional off-board battery charger. Do not use an automotive-type battery charger.



WARNING! Inspect the battery charger, wiring, and connectors for damage before each use. Contact your Quantum Rehab Specialist if damage is found.

WARNING! Do not attempt to open the battery charger case. If the battery charger does not appear to be working correctly, contact your Quantum Rehab Specialist.

WARNING! If the battery charger is equipped with cooling slots, then do not attempt to insert objects through these slots.

VII. BATTERIES AND CHARGING



WARNING! If your battery charger has not been tested and approved for outdoor use, then do not expose it to adverse or extreme weather conditions. If the battery charger is exposed to adverse or extreme weather conditions, then it must be allowed to adjust to the difference in environmental conditions before use indoors. Refer to the manual supplied with the battery charger for more information.

To charge the batteries using the onboard charger:

1. Position the rear of your power chair next to a standard electrical outlet.
2. Be certain the controller power is turned off and the freewheel levers are in the engaged position. See III. “Your Power Chair.”
3. Slide the rear cover forward.
4. Extend the charger power cord and plug it into the electrical outlet.

NOTE: *The power chair incorporates an inhibit function that disables the power chair when the charger is plugged into an electrical outlet.*

5. We recommend you charge the batteries for 8 to 14 hours. As the batteries charge, the ammeter needle slowly drops to zero.

NOTE: *The ammeter indicates how much charge is needed to fully charge the batteries. Wait about a minute for the charger to warm up. The ammeter may move as high as 5.5 amps, then gradually move back down to 0 amps as the batteries charge.*

6. When the batteries are fully charged, the needle vibrates on or near the zero mark on the ammeter scale. Unplug the power cord from the electrical outlet, wind it up using the hook and loop strap, and place the cord back into the electronics tray.

To charge the batteries using the off-board charger:

1. Position the front of your power chair next to a standard electrical outlet.
2. Turn off the power to the controller and engage the manual freewheel lever(s) in the drive position. See III. “Your Power Chair.”
3. Plug the 3-pin extension cable from the off-board battery charger into the off-board battery charger/programming socket on the controller.
4. Plug the off-board battery charger into the electrical outlet.

NOTE: *If it is a Pride off-board charger, then there are two lights in it. The red light indicates that power to the off-board charger is on. The green light indicates that the batteries are fully charged. If it is not a Pride off-board charger, then follow the instructions supplied by the manufacturer.*

5. When the batteries are fully charged, disconnect the charger from the electrical outlet, then from the controller.

VII. BATTERIES AND CHARGING

Battery Break-In

To break in new batteries for maximum efficiency:

1. Fully recharge any new battery prior to its initial use. This brings the battery up to about 90% of its peak performance level.
2. Operate your power chair about the house and yard. Move slowly at first, and do not travel too far until you become accustomed to the controls and break in the batteries.
3. Give the batteries another full charge of 8 to 14 hours and operate your power chair again. The batteries should now perform at over 90% of their potential.
4. After four or five charging cycles, the batteries top off at 100% charge and last for an extended period.

Frequently Asked Questions (FAQs)

How does the charger work?

The battery charger takes the standard electrical outlet voltage of 120 VAC (alternating current) and converts it to 24 VDC (direct current). The power chair batteries use direct current to run your power chair. When the battery voltage is low, the charger works harder to charge the battery. As the battery voltage approaches full charge, the charger doesn't work as hard to complete the charging cycle. When the battery is fully charged, the amperage from the charger is nearly at zero. This is how the charger maintains a charge but does not overcharge the battery.

Can I use a different battery charger?

You should use the charger supplied with the power chair. It is the safest, most efficient tool to charge the batteries. We do not recommend using other types of chargers (e.g., an automotive battery charger).

NOTE: Your power chair's charger will not operate after the batteries have been discharged to nearly zero voltage. If this happens, call your Quantum Rehab Specialist for assistance.

How often must I charge the batteries?

Many factors come into play when deciding how often to charge the batteries. You may use your power chair all day on a daily basis or you may not use it for weeks at a time.

■ Daily Use

If you use your power chair on a daily basis, charge the batteries as soon as you are finished. Your power chair will be ready each morning to give you a full day's service. It is recommended that you charge the batteries 8 to 14 hours after daily use.

■ Infrequent Use

If you use your power chair infrequently (once a week or less), you should charge the batteries at least once per week for 12 to 14 hours.

NOTE: Keep your batteries fully charged and avoid deeply discharging your batteries. Do not charge the batteries for more than 24 hours at a charging cycle.

VII. BATTERIES AND CHARGING

How can I get maximum range or distance per charge?

Rarely do you have an ideal driving situation such as smooth, flat, hard terrain with no wind, hills, or curves. More often you are presented with hills, sidewalk cracks, uneven and loosely packed surfaces, curves, and wind. All of these factors affect the distance or running time per battery charge. The following are a few suggestions for obtaining the maximum range per charge.

- Always fully charge the batteries prior to your trip.
- Maintain **35 psi (2.4 bar)** in pneumatic drive wheels.
- Plan your trip in advance to avoid inclines if possible.
- Limit baggage weight to essential items.
- Try to maintain an even speed and avoid stop-and-go driving.

What type of battery should I use?

We recommend deep-cycle batteries that are sealed and maintenance free. Both AGM and Gel-Cell are deep-cycle batteries that are similar in performance. Refer to the Specification Table for more information regarding the batteries used with your power chair.



WARNING! Corrosive chemicals are contained in batteries. Use only AGM or Gel-Cell batteries to reduce the risk of leakage or explosive conditions.

Why do my new batteries seem weak?

Deep-cycle batteries employ a much different chemical technology than that used in car batteries, nickel-cadmium batteries (nicads), or in other common battery types. Deep-cycle batteries are specifically designed to provide power, drain down their charge, and then accept a relatively quick recharge. AGM and Gel-Cell batteries should be charged as often as possible. They do not have a “memory” like nickel-cadmium batteries.

We work closely with our battery manufacturer to provide a battery that best suits your power chair’s specific demands. Fresh batteries arrive regularly at Pride and are promptly shipped with a full charge. During shipping, the batteries encounter temperature extremes that may influence initial performance. Heat robs the charge from the battery, and cold slows the power available and extends the time needed to recharge the battery (just as with a car battery).

It might take a few days for the temperature of the battery to stabilize and adjust to its new ambient temperature. More importantly, it takes a few “charging cycles” (a partial drain—then a full recharge) to establish the critical chemical balance that is essential to the battery’s peak performance and long life. It is well worth it to take the time to break in your battery properly.

NOTE: *The useful life of a battery is quite often a reflection of the care it receives.*

How can I ensure maximum battery life?

A fully charged, deep-cycle battery provides reliable performance and extended battery life. Keep your power chair’s batteries fully charged whenever possible. Batteries that are regularly and deeply discharged, infrequently charged, or stored without a full charge may be permanently damaged, causing unreliable power chair operation and limited battery life.

VII. BATTERIES AND CHARGING

How should I store my power chair and its batteries?

If you do not use your power chair regularly, we recommend maintaining battery vitality by charging the batteries at least once a week.

If you do not plan on using your power chair for an extended period, fully charge the batteries prior to storage. Disconnect the battery harnesses and store the power chair in a warm, dry environment. Avoid temperature extremes, such as freezing and excessively hot conditions, and never attempt to charge a frozen battery. A cold or frozen battery should be warmed for several days prior to recharging.

***NOTE:** If you are storing a power chair for an extended period of time, you may wish to block the unit up with several boards under the frame. This keeps the tires off the ground and prevents the possibility of flat spots developing in the tires.*

What about public transportation?

AGM and Gel-Cell batteries are designed for application in power chairs and other mobility vehicles. These batteries are Federal Aviation Administration (FAA) approved, allowing safe transportation on aircraft, buses, and trains, as there is no danger of spillage or leakage. We suggest you contact the carrier's ticket counter in advance to determine that carrier's specific requirements.

What about shipping?

If you wish to use a freight company to ship your power chair to your final destination, repack your power chair in the original shipping container and ship the batteries in separate boxes.

VIII. CARE AND MAINTENANCE

CARE AND MAINTENANCE

Your Quantum 1402 is a sophisticated power chair. Like any motorized vehicle, it requires routine maintenance checks. You can perform some of these checks, but others require assistance from a Quantum Rehab Specialist. Preventive maintenance is very important. If you follow the maintenance checks in this section as scheduled, you can help ensure that your power chair gives you years of trouble-free operation. If you have any doubt as to your power chair's care or operation, contact your Quantum Rehab Specialist.



WARNING! Do not service the power chair when the seat is occupied.

Your power chair, like most electrical equipment, is susceptible to damage from the elements. Avoid damp areas of any kind.



WARNING! Direct or prolonged exposure to water or dampness could cause the power chair to malfunction electronically and mechanically. Water can cause electrical components to corrode and the chair's frame to rust. Power chairs should be examined periodically for signs of corrosion caused by water exposure, bodily fluid exposure, or incontinence. Damaged components should be replaced or treated immediately.

Should your power chair come in contact with water:

1. Dry your power chair as thoroughly as possible with a towel.
2. Allow your power chair to sit in a warm, dry place for 12 hours to allow unseen water to evaporate.
3. Check the joystick operation and the brakes before using your power chair again.
4. If any inconsistencies are found, take your power chair to a Quantum Rehab Specialist. Power chairs that are frequently exposed to sources of water, such as incontinence, should be inspected often for corrosion and electronic components may need to be replaced frequently.

Temperature

- Some of the parts of your power chair are susceptible to extreme changes in temperature. Always keep your power chair between the temperatures of 18°F (-8°C) and 122°F (50°C).
- In extremely cold temperatures the batteries may freeze. The specific temperature at which they freeze depends on a number of factors, such as battery charge, usage, and composition of the batteries (e.g., AGM or Gel-Cell).
- Temperatures above 122°F (50°C) may cause your power chair to operate at a reduced speed. This reduced speed is a safety feature built into the controller that helps prevent damage to the motor and other electrical components.

General Guidelines

- Avoid knocking or bumping the controller, especially the joystick.
- Avoid prolonged exposure of your power chair to extreme conditions, such as heat, cold, or moisture.
- Keep the controller clean.
- Check all connectors on the electronics tray to ensure that they are all tight and secured properly.
- Make sure the drive tires are inflated to **35 psi (2.4 bar)**.



WARNING! Make sure your tires are inflated to 35 psi (2.4 bar). Do not underinflate or overinflate your tires. Low pressure may result in loss of control, and overinflated tires may burst. Overinflating tires can cause them to explode.

WARNING! Do not use a high pressure hose to inflate your tires.

- Use a rubber conditioner on the tire sidewalls to help preserve them.



WARNING! Never use a rubber conditioner on the tread area of the tires; doing so may make the tires slippery and cause your power chair to skid.

VIII. CARE AND MAINTENANCE

- All wheel bearings are prelubricated and sealed. They require no subsequent lubrication.
- The body shroud has been sprayed with a clear sealant coating. You can apply a light coat of car wax to help it retain its high-gloss appearance.
- Check all electrical connections. Make sure they are tight and are not corroded. Batteries must sit flat within the battery well, with the battery terminals facing inward, toward each other. Refer to the frame decal for the correct wiring layout.



WARNING! Even though the power chair has passed the necessary testing requirements for ingress of liquids, you should keep electrical connections away from sources of dampness, including direct exposure to water or bodily fluids and incontinence. Check electrical components frequently for signs of corrosion and replace as necessary.

Daily Checks

- With the controller turned off, check the joystick. Make sure it is not bent or damaged and that it returns to the center when you release it. Check the rubber boot around the base of the joystick for damage. Visually inspect the boot. Do not handle or try to repair it. See your Quantum Rehab Specialist if there is a problem.
- Visually inspect the controller harnesses. Make sure that they are not frayed or cut or have any wires exposed. See your Quantum Rehab Specialist if there is a problem with any of these harnesses.
- Check for flat spots on solid tires. Flat spots could adversely affect stability.

Weekly Checks

- Disconnect and inspect the controller and the charger harnesses from the electronics tray. Look for corrosion. Contact your Quantum Rehab Specialist if necessary.
- Ensure that all parts of the controller system are securely fastened to your power chair. Do not overtighten any screws.
- Check for proper tire inflation. There should be **35 psi (2.4 bar)** in each tire. If a tire does not hold air, see a Quantum Rehab Specialist for replacement of the tube.
- Check the brakes. This test should be carried out on a level surface with at least three feet (1 meter) of clearance around your power chair.

To check the brakes:

1. Turn on the controller and turn down the speed level of your power chair.
2. After one second, check the battery condition meter. Make sure that it remains on.
3. Slowly push the joystick forward until you hear the electric brakes click. Immediately release the joystick. You must be able to hear each electrical brake operating within a few seconds of joystick movement. Repeat this test three times, pushing the joystick backwards, then left, and then right.

Monthly Checks

- Check that the anti-tip wheels do not rub the ground when you are operate your power chair. Adjust them as necessary. See V. “Comfort Adjustments.”
- Check for extreme wear on the anti-tip wheels. Replace them as necessary.
- Check for drive tire wear. See a Quantum Rehab Specialist for repair.
- Check the rear casters for wear. Replace them as necessary.
- Check the rear forks for damage or fluttering which indicates that they may need to be adjusted or have the bearings replaced. See a Quantum Rehab Specialist for repair.
- Keep your power chair clean and free of foreign material, such as mud, dirt, hair, food, drink, etc.

Yearly Checks

Take your power chair to a Quantum Rehab Specialist for yearly maintenance, especially if you use your power chair on a daily basis. This helps ensure that your power chair is functioning properly and helps prevent future complications.

VIII. CARE AND MAINTENANCE

Storage

Your power chair should be stored in a dry place, free from temperature extremes. When storing, disconnect the batteries from the power chair. See VII. “Batteries and Charging.”



WARNING! If you fail to store the unit properly, the frame can rust and the electronics can be damaged.

Batteries that are regularly and deeply discharged, infrequently charged, stored in extreme temperatures, or stored without a full charge may be permanently damaged, causing unreliable performance and limited service life. It is recommended that you charge the batteries periodically throughout periods of prolonged storage to ensure proper performance.

You may wish to place several boards under the frame of your power chair to raise it off of the ground during periods of prolonged storage. This takes the weight off the tires and reduces the possibility of flat spots developing on the areas of the tires contacting the ground.

Disposal of Your Power Chair

Your power chair must be disposed of according to applicable local and national statutory regulations. Contact your local waste disposal agency or a Quantum Rehab Specialist for information of proper disposal of power chair packaging, metal frame components, plastic components, electronics, and batteries.

Cleaning Instructions

- Use a damp cloth and mild, non-abrasive cleanser to clean the plastic and metal parts of your power chair. Avoid using products that may scratch the surface of your power chair.
- If necessary, clean your product with an approved disinfectant. Make sure the disinfectant is safe for use on your product before application.

WARNING! Follow all safety instructions for the proper use of the disinfectant and/or cleaning agent before applying it to your product. Failure to comply may result in skin irritation or premature deterioration of upholstery and/or power chair finishes.



WARNING! Never hose off your power chair or place it in direct contact with water. Your power chair has a painted, ABS plastic body shroud that allows it to be easily wiped clean with a damp cloth.

WARNING! Never use any chemicals to clean a vinyl seat, as they may cause the seat to become slippery or dry out and crack. Use soapy water and dry the seat thoroughly.

Wheel Replacement

If you have pneumatic tires and you have a flat tire, replace the tube. If your chair is equipped with a solid tire insert, then replace the entire wheel assembly. Replacement tires, tubes, and wheel assemblies are readily available through your Quantum Rehab Specialist.

WARNING! The wheels on your power chair should only be serviced or replaced by a Quantum Rehab Specialist or a qualified technician.



WARNING! Be sure that the power to the controller is turned off and the power chair is not in freewheel mode before performing this procedure.

WARNING! When changing a tire, remove only the center lug nut and washer, then remove the wheel. If any further disassembly is required, deflate the tire completely or it may explode.

VIII. CARE AND MAINTENANCE

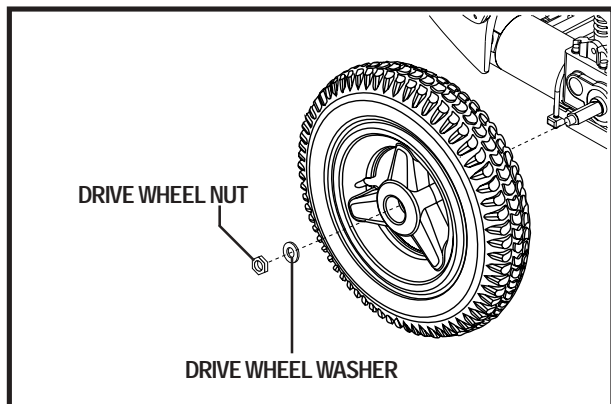

Figure 24. Quantum 1402 Drive Wheel

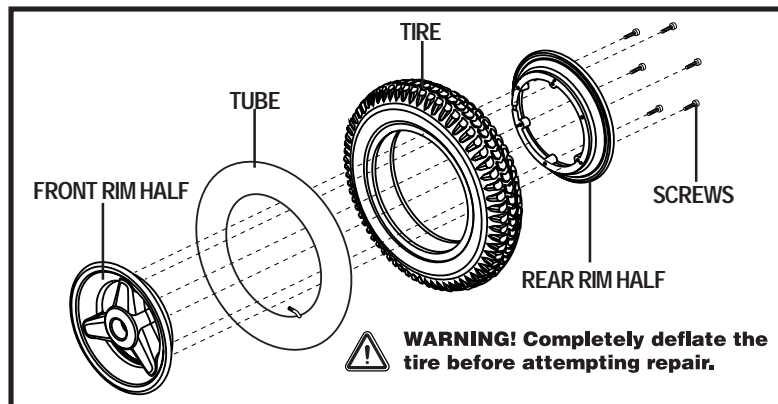

Figure 25. Quantum 1402 Drive Wheel Disassembled

Follow these easy steps for a quick and safe repair for both solid and pneumatic tires:

1. Turn off the power to the controller.
2. Set the power chair up on blocks.
3. If you are changing a pneumatic tire, completely deflate it before removing the wheel.
4. Remove the drive wheel nut and washer from the axle. See figure 24.
5. Pull the wheel off the axle.
6. Remove the screws from the rim assembly and separate the front and rear rim. See figure 25.
7. Remove the old tube from the pneumatic tire and replace it with a new tube or replace the entire assembly if it is a solid tire.
8. Reassemble the rims and reinstall the screws.
9. Slide the wheel back onto the axle.
10. Reinstall the drive wheel nut and washer onto the axle and tighten.
11. Inflate the pneumatic tires to **35 psi (2.4 bar)**.
12. Remove the power chair from the blocks.

Battery Replacement

A diagram is printed on a decal on your power chair frame near the battery tray. See figure 26.



MANDATORY! Battery posts, terminals, and related accessories contain lead and lead compounds. Wear goggles and gloves when handling batteries and wash hands after handling.

WARNING! The batteries in your power chair should only be serviced or replaced by a Quantum Rehab Specialist or a qualified technician.



WARNING! Do not replace the batteries when the seat is occupied.

WARNING! Do not mix or match new and old batteries. If you encounter a situation where one battery needs to be replaced, then replace both batteries. Refer to specifications table in this manual and the manual supplied with the battery charger for recommended type and capacities.

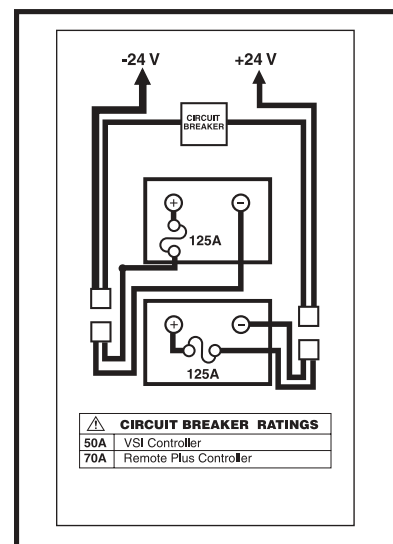

Figure 26. Battery Connections

Battery Replacement

A diagram is printed on a decal on the power chair frame near the battery tray.

To replace the battery:

1. Turn off the power to the controller.
2. Remove the detent pin from the bottom of the foot frame. See figure 17.
3. Lift the foot frame straight up to remove it from the mounting bracket.
4. Locate the two wiring harnesses that are attached to the batteries.
5. Disconnect the two harnesses from their respective quick disconnects by pulling the quick disconnects toward you.
6. Remove the batteries from the power base assembly.
7. Disconnect the battery harnesses from the positive and negative terminals.
8. Replace the old batteries with new ones.
9. Connect the wire labeled BAT (+) to the positive (red) terminal of one battery.
10. Connect the wire labeled BAT (-) to the negative (black) terminal of the same battery.
11. Install the battery into the rear of the battery tray with the battery terminals facing inward, toward the center of the power chair. Plug the wiring harness into a quick disconnect.
12. Connect the wire labeled BAT (+) to the positive (red) terminal of the other battery.
13. Connect the wire labeled BAT (-) to the negative (black) terminal of the same battery.
14. Install the battery into the front of the battery tray with the battery's terminals facing inward, toward the center of the power chair. Plug the wiring harness into a quick disconnect.



WARNING! Make sure you tighten the fasteners so that the connections are secure.

15. Replace the foot frame using the detent pin to secure.

When to See Your Quantum Rehab Specialist for Service

The following symptoms could indicate a serious problem with your power chair. If necessary, contact your Quantum Rehab Specialist. When calling, have the model number, serial number, nature of the problem, and the trouble code if available.

- Motor noise
- Frayed harnesses
- Cracked or broken connectors
- Uneven wear on any of the tires
- Jerky motion
- Pulling to one side
- Bent or broken wheel assemblies
- Does not power up
- Powers up, but does not move

VIII. CARE AND MAINTENANCE

Corrective Maintenance

If the battery condition meter does not light up when you turn on the power:

- Check the harness connections. Make sure they are tight.
- Check the circuit breaker. Reset it if necessary.
- Check the battery connections.

If the above conditions prove normal, you can load test the batteries with a battery load tester. These testers are available at automotive parts stores. Disconnect both batteries before load testing and follow the directions that come with the load tester. If either one of the batteries fails the load test, replace both of them. If your power chair still does not power up, contact your Quantum Rehab Specialist.

I X . W A R R A N T Y

LIFETIME LIMITED WARRANTY

For the lifetime of your power chair from the date of purchase, Pride will repair or replace at our option to the original purchaser, free of charge, any of the following parts found upon examination by an authorized representative of Pride to be defective in material and/or workmanship:

Structural frame components, including:

- Main Frame
- Fixed-position seat post

TWO-YEAR LIMITED WARRANTY

For two (2) years from the date of purchase, Pride will repair or replace at our option to the original purchaser, free of charge, any of the following parts found upon examination by an authorized representative of Pride to be defective in material and/or workmanship:

Electronic components, including:

- Charger Assembly
- Controller
- Joystick

Main frame assemblies, including:

- Anti-tip forks
- Caster forks
- Caster beam
- Metal seat framing

Other components, including:

- Foot riggings
- Electrical Harnesses
- Foot rigging mounting brackets

18-MONTH LIMITED WARRANTY

For eighteen (18) months from the date of purchase, Pride will repair or replace at our option to the original purchaser, free of charge, any of the following parts found upon examination by an authorized representative of Pride to be defective in material and/or workmanship:

- Motor/gearbox assembly
- Power seat actuator

ONE-YEAR LIMITED WARRANTY

For one (1) year from the date of purchase, Pride will repair or replace at our option to the original purchaser, free of charge, any of the following parts found upon examination by an authorized representative of Pride to be defective in material and/or workmanship:

- Accessories
- Brakes (electronic function ONLY)

SIX-MONTH LIMITED WARRANTY

For six (6) months from the date of purchase, Pride will repair or replace at our option to the original purchaser, free of charge, any of the following parts found upon examination by an authorized representative of Pride to be defective in material and/or workmanship:

- Bearings and bushings
- Plastic components, except body

The battery is covered by a separate six-month warranty, provided by the battery manufacturer. The batteries are not warranted by Pride.

IX . WARRANTY

RECONDITIONED UNITS WARRANTY

All reconditioned units are covered by a six-month warranty from Pride effective from the date of purchase.

WARRANTY EXCLUSIONS

This warranty does not extend to those items which may require replacement due to normal wear and tear.

- ABS Plastic shrouds
- Brake Pads
- Motor brushes
- Tires and tubes
- Upholstery and seating
- Fuses/Bulbs
- Circumstances beyond the control of Pride
- Labor, service calls, shipping, and other charges incurred for repair of the product, unless specifically authorized, IN ADVANCE, by Pride Mobility Products Corporation
- Repairs and/or modifications made to any part without specific consent from Pride

Exclusions also include components with damage caused by:

- Contamination
- Abuse, misuse, accident, or negligence
- Battery fluid spillage or leakage
- Commercial use, or use other than normal
- Improper operation, maintenance, or storage

NOTE: Gradual deterioration in performance because the battery has been left in a discharged state, left in cold conditions for an extended period of time, or worn out through heavy use is not covered.

SERVICE CHECKS AND WARRANTY SERVICE

Warranty service must be performed by a Quantum Rehab Specialist. Do not return faulty parts to Pride without prior written authorization. All transportation costs and shipping damage incurred while submitting parts for repair or replacement are the responsibility of the purchaser.

Failure to follow the instructions, warnings, and notes in the owner's manual and those located on your Pride product can result in personal injury or product damage and will void Pride's product warranty.

There is no other express warranty.

IMPLIED WARRANTIES

Implied warranties, including those of merchantability and fitness for a particular purpose, are limited to one (1) year from the date of purchase and to the extent permitted by law. Any and all implied warranties are excluded. This is the exclusive remedy. Liabilities for consequential damages under any and all warranties are excluded.

Some states do not allow limitations on how long an implied warranty lasts or do not allow the exclusion of limitation incidental or consequential damages. The above limitation or exclusion may not apply to you.

This warranty gives you specific rights, and you may also have other rights which vary from state to state.

Please fill out and return the product registration card to Pride. This will aid Pride in providing the best possible technical and customer service.

APPENDIX I - SPECIFICATIONS

SPECIFICATIONS	
Suspension:	Active-Trac system and rear suspension
Drive Wheels:	14 in. (35.5 cm), pneumatic or solid, center-mounted
Caster Wheels:	8 in. (20.32 cm), solid, rear articulating
Anti-tip Wheels:	6 in. (15.24 cm), solid, front-mounted
Maximum Speed: ¹	Up to 4.5 mph (7.25 km/h) with high-torque motors (standard) Up to 6 mph (9.65 km/h) with high-speed motors (optional)
Range: ¹	Variable up to 25 miles (40 km)
Brakes:	“Intelligent Braking,” electronic, regenerative disc brakes
Ground Clearance: ²	See figure 27.
Turning Radius: ²	See figure 27.
Overall Size: ²	Length: See figure 27. Width: See figure 27.
Drivetrain:	Two-motor, mid-wheel
Batteries: ³	Two 12-volt deep-cycle, Group 24 batteries NF-22 batteries for the power seat option
Battery Charger:	8-amp, off-board (standard) 5-amp, onboard (optional) 5-amp, onboard/8-amp, off-board combo (optional)
Weight Capacity:	400 lbs. (181 kg) with high-torque motors 325 lbs. (147 kg) with high-speed motors
Component Weights:	Base: 129 lbs. (58.5 kg) Batteries: 53.5 lbs. (24 kg) each

¹ Varies with base model, user weight, terrain type, battery amp hour rating (Ah), battery charge, battery condition, motors, controller type, tire type, and tire condition.

² Due to manufacturing tolerances and continued product improvement, this specification can be subject to a variance of (+ or -) 3%.

³ AGM or Gel-Cell type required. See VII. “Batteries and Charging.”

NOTE: All specifications subject to change without notice.

APPENDIX I - SPECIFICATIONS

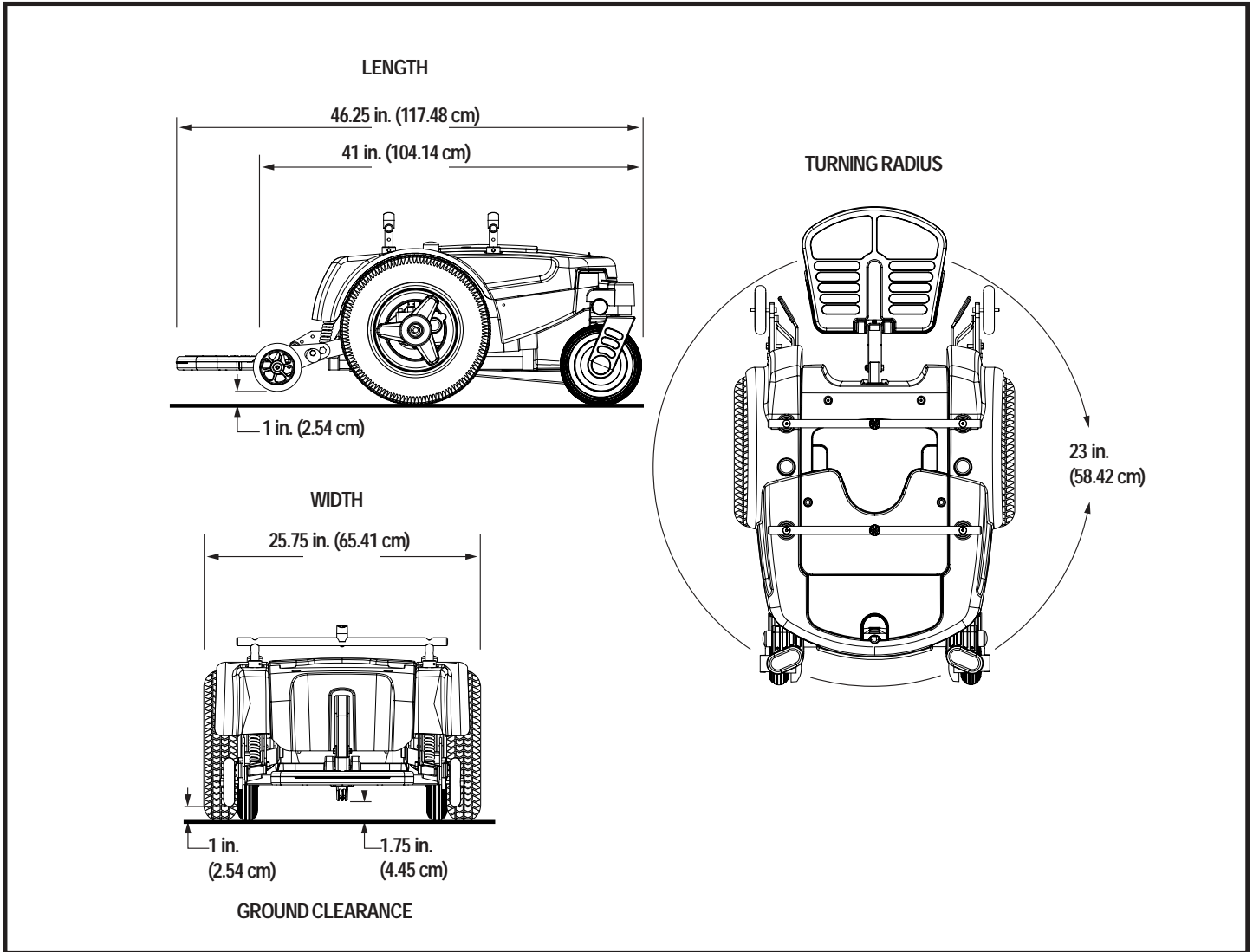

Figure 27. Quantum 1402 Dimensions and Ground Clearance

NOTES

NOTES

Quality Control - Quantum 1402

Inclusion of all Parts

Joystick Serial Number

Controller Serial Number

Left Motor Serial Number

Right Motor Serial Number

Fit and Finish

Performance



Pride keeps a more detailed report on file at the factory.

Date Inspected

Inspector

I NFMANU2669

Product Serial #