

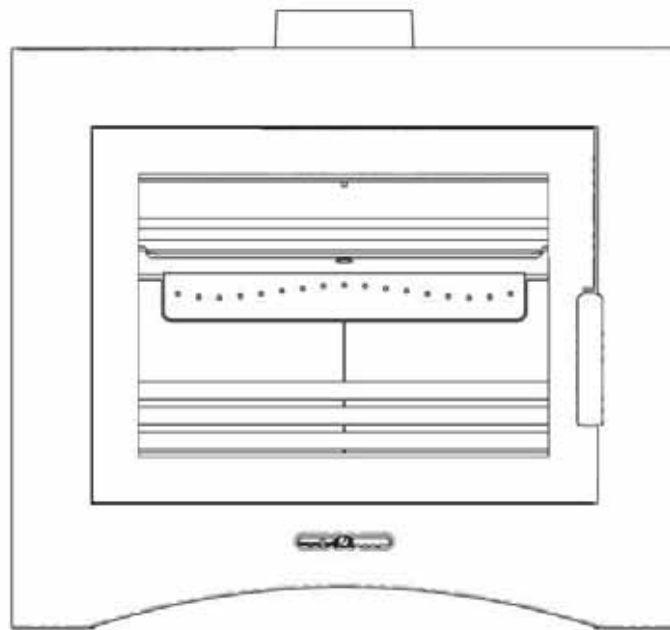

Installation & Operating Instructions



Covering Models:

eVolution 26 Boiler
Wood Burning Stove



Tested to EN 13240



These appliances must be installed and commissioned by a HETAS registered engineer



Contents

Introduction	3
Packing List	3
Health & Safety	4
Specifications	5
Dimensions	6
Hearth Requirements & Clearances	7
Chimney Requirements	8
Combustion Air Requirements	9
Assembly	10
Plumbing Advice	13
Plumbing Maintenance	20
Plumbing Diagrams	21
Commissioning & Handover	30
Stove Operation	
Controls Layout	31
Controls Explained	32
Recommended Fuels	33
Lighting the Stove	
Kindling Stage	34
Burning Wood	35
Smoke Exempt Requirements	36
Warning Notes	37
Maintenance	
Ash Removal	38
Chimney Fires	38
General Stove Cleaning	38
Glass Cleaning	38
Annual Stove Service	38
Chimney Sweeping	39
Flue Ways & Boiler Cleaning	39
Trouble-shooting	40
Commissioning Form	41
Spare Parts	43
EC Declaration	44
Annual Service Record	45
Warranty	46



Introduction

May we take this opportunity to thank you for choosing one of our stoves.

These appliances are designed to burn hardwood logs. It is essential that your wood has been seasoned to ensure that it is sufficiently dry for burning. You can determine the moisture content of your logs by using a digital moisture meter, your logs need to be below 20% moisture content (Preferably in the centre of the log) before they are considered dry enough for burning. Never burn wood that contains paint, glue or any other chemicals

See the section “Recommended Fuels” & “Lighting the Stove” for further details. After reading this document, if there is anything you are unsure about, please contact your dealer or our Technical Support Department.

These instructions cover the basic principles to ensure the satisfactory installation of the stove, although detail may need slight modification to suit particular local site conditions. In all cases the installation must comply with current Building Regulations, Local Authority By-laws and other specifications or regulations as they affect the installation of the stove.

It should be noted that the Building Regulations requirements may be met by adopting the relevant recommendations given in British Standards BS 8303, BS 6461 and BS 7566 as an alternative means to achieve an equivalent level of performance to that obtained following the guidance given in Approved Document J.

Please note that it is a requirement under the Broseley Fires warranty system that the installation of the stove is carried out by a Competent Person registered with a Government approved Competent Persons Scheme. HETAS Ltd operate such a Scheme and a listing of their Registered Competent Persons can be found on their website at www.hetas.co.uk. Your installer is responsible for designing and implementing any aspect of the installation, he/she may sub-contract certain areas but all work must be done to your installers design and specification.

Packing List

1x Cast Iron/Steel Stove	1x Log retainer set
2x Rear Firebricks	1x Spigot & Fixings
4x Bottom Firebricks	1x Spigot Ring
1x Front Baffle	1x Ash Tool & Glove Set
1x Grate Support Set	1x Smoke Exempt Washer
2x Side Firebricks	1x Instruction Booklet
4x Grates	
2x Ashpans	

All separate parts will be inside the main stove body.



Health & Safety

Special care must be taken when installing the stove such that the requirements of the Health and Safety at Work Act are met.

Installation

This appliance MUST be installed and commissioned by a HETAS registered installer in England and Wales and a fully qualified Heating Engineer in Scotland and Ireland.

Handling

Adequate facilities must be available for loading, unloading and site handling.

Fire Cement

Some types of fire cement are caustic and should not be allowed to come into contact with the skin. In case of contact wash immediately with plenty of water.

Asbestos

This stove contains no asbestos. If there is a possibility of disturbing any asbestos in the course of installation then please seek specialist guidance and use appropriate protective equipment.

Metal Parts

When installing or servicing this stove care should be taken to avoid the possibility of personal injury.

CO Alarms

Building regulations require that whenever a new or replacement fixed solid fuel or wood/biomass appliance is installed in a dwelling an audible carbon monoxide alarm must be fitted in the same room as the appliance. Further guidance on the installation of the carbon monoxide alarm is available in BS EN 50292:2002 and from the alarm manufacturer's instructions. Provision of an alarm must not be considered a substitute for either installing the appliance correctly or ensuring regular servicing and maintenance of the appliance and chimney system.

Fire Guards

When using the stove in situations where children, aged and/or infirm persons are present a fireguard must be used to prevent accidental contact with the stove. The fireguard should be manufactured in accordance with BS 6539.

Aerosol Sprays

Do not use an aerosol spray on or near the stove when it is alight.

Operating Tool & Gloves

Always use the operating tool and glove provided when handling parts likely to be hot when the stove is in use.



Specifications

In the UK these stoves have been approved by HETAS Ltd as intermittent heating appliances for burning Hardwood logs only.

Appliance Weight (Kg)	320
Nominal total heat output	25.9
Nominal heat output to room (kW)	10.1
Nominal heat output to water (kW)	15.8
Flue diameter MINIMUM	150mm/6"
Efficiency %	77.9
Maximum fuel load of wood to maintain nominal output (Kg / hr)	5.69
Maximum wood length – Must be Split Logs	35cm
Wood Moisture Content Less than	20.00%
Temperature exhaust gas – wood (°C)	241
Optimal working temperature	70° - 75°
Boiler capacity (Litres)	30
Flow & return pipe fitting (Female)	1" BSP
SCWS flow & outlet pipe fittings (Male)	3/4" BSP
Flue draft Pressure (Pascals)	14 – 20
Minimum flue height in meters (straight)	5
Maximum working temperature	94° - 95°
Maximum allowable water pressure (bar)	3

European standards need to be complied to when installing this appliance.

Dimensions

All dimensions are in millimetres

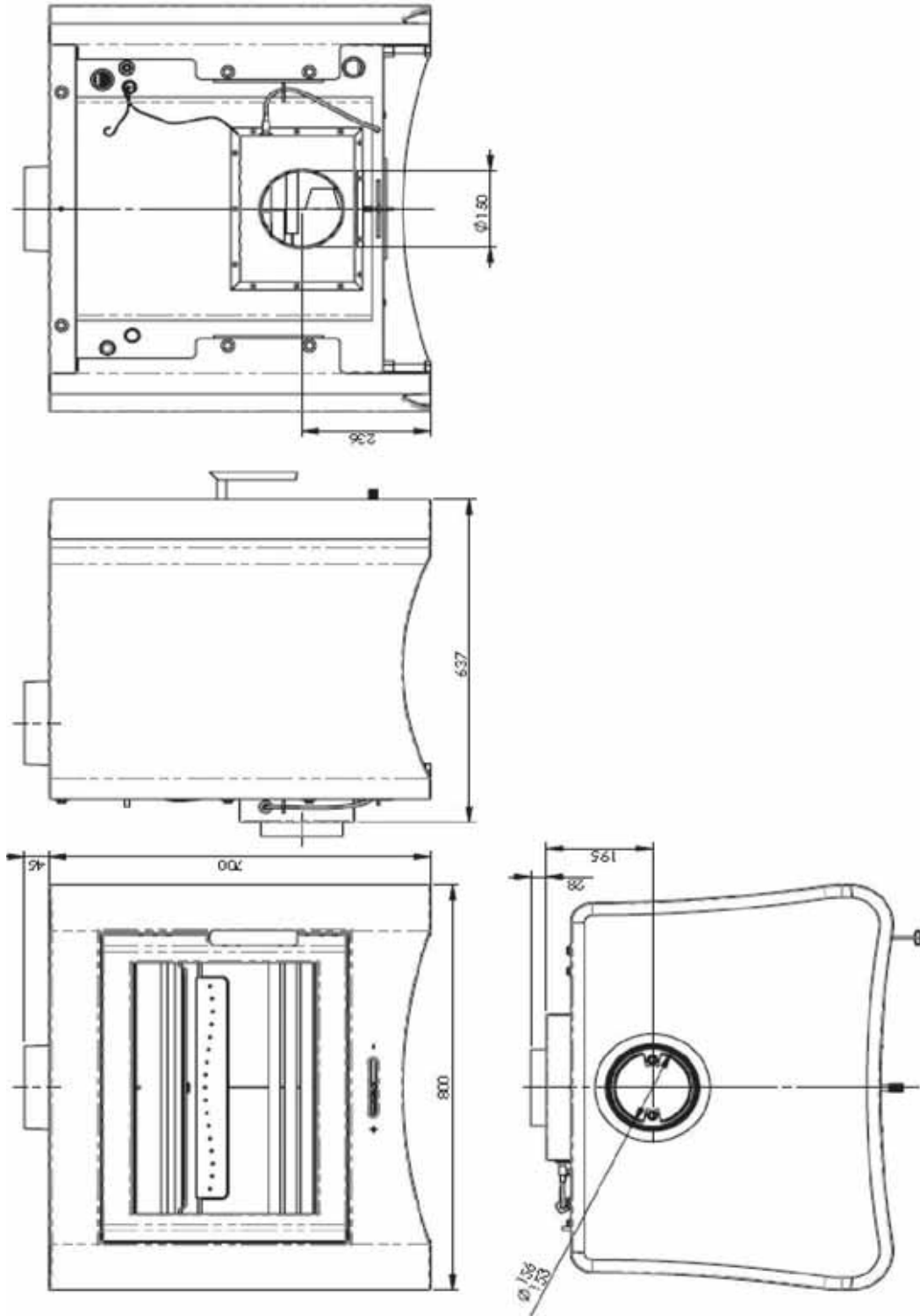

Hearth Requirements & Clearances

This appliance is suitable for non-combustible hearths with a minimum thickness of 12mm, they do not require a full constructional hearth.

Your stove must be installed on a solid, level non-combustible hearth. The hearth protrusion in front of the stove to carpets or wooden floors must be at least 300mm. As it is possible, that on opening the door of the stove for fuel to fall out, a fender must be fitted if the hearth is flush with the carpet. These are just a few hearth specifications. Please refer to Building Regulations Approved Document J (Hearths) for more specific details.

Clearances

The stove requires the following clearances around it to ensure the heat is released into the room and to allow sufficient combustion air flow. A combustible material clearance is given to prevent damage to any items that may be affected by heat.

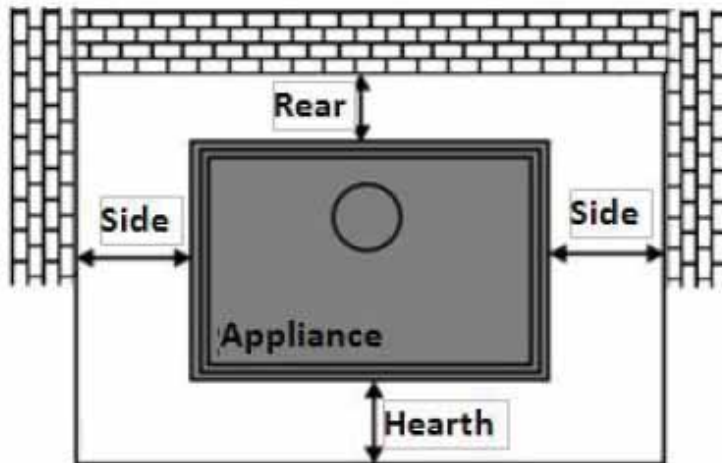

Stove Clearances	Rear	Side	Hearth	Above
Non-Combustible	150mm	100mm	300mm	200mm
Combustible	150mm	150mm	300mm	600mm

Chimney Requirements

This appliance must not be fitted into a chimney serving another heating appliance. It is most important that there is no obstruction in the flue or chimney. Please ensure that any existing chimney is clear of obstruction and swept clean immediately before installation of the new stove. If the chimney has been used for an open fire it is recommended that it be swept for a second time having been used for a month following installation.

A flue draught minimum of 14 Pascals to a maximum 20 Pascals is required for satisfactory appliance performance. A properly built masonry or factory constructed chimney (with a minimum vertical height of 5 metres) should ensure a consistent draught (draw). 45° bends can be used in the flue run (maximum of four bends) you will need to add an extra 1 metre of vertical flue height for each bend.

The flue draught should be checked under fire at high output and if it exceeds the recommended maximum, a draught stabiliser must be fitted so that the rate of burning can be controlled, and to prevent over firing (See section “Warning Notes”). If you have any doubts about the suitability of your chimney, consult your local dealer/stockist or engineer. If your flue draft is below the minimum recommendation then it may be necessary to increase the vertical chimney height, add additional flue insulation or possibly add a special cowl to the top of the chimney (e.g. anti down draft cowl to eliminate wind induced down draft).

The outlet from the chimney should be above the roof of the building in accordance with the provisions of Building Regulations Approved Document J.

If installation is into an existing chimney then it must be sound and have no cracks or other faults which might allow fumes into the house. Older properties, especially, may have chimney faults or the cross section may be too large i.e. more than 230 mm x 230 mm. Remedial action should be taken, if required, seeking expert advice, if necessary. If it is found necessary to line the chimney then a flue liner suitable for solid fuel must be used in accordance with Building Regulations Approved Document J.

If there is no existing chimney then either a prefabricated block chimney in accordance with Building Regulations Approved Document J or a twin walled insulated stainless steel flue to BS 4543 can be used. These chimneys must be fitted in accordance with the manufacturer’s instructions and Building Regulations.

If a flexible liner is required the liner diameter must not be less than 6”.

Any bend in the chimney or connecting fluepipe should not exceed 45°. 90° bends are not permitted. . For top flue installations it is possible to sweep through the appliance by removing the internal baffle however it is recommended that you provide adequate access (e.g. easily accessible soot door).

Combustion Air Requirements

In order for the stove to perform efficiently and safely there should be an adequate air supply into the room in which the stove is installed to provide combustion air. This is particularly necessary in modern houses where drafts have been almost eliminated by double glazing etc.

Under UK building regulations any appliance over 5kW MUST have a fixed permanent air vent (see building regulations approved document J for further information).

There must not be an extractor fan fitted in the same room as the stove as this can cause the stove to emit fumes into the room. It is necessary to install a wall vent to provide the necessary combustion air and to prevent the depletion of oxygen in the room.

It is possible to direct vent this appliance by connecting a 150mm/6" diameter pipe to the spigot on the back of the appliance using a suitable pipe and clip (not supplied).

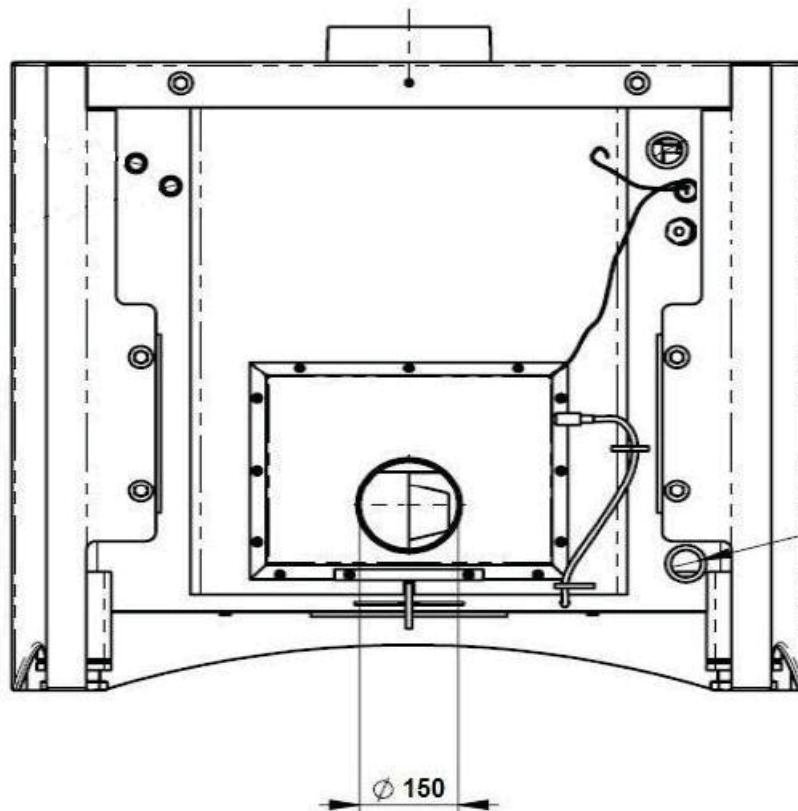

Assembly

The diagrams below shows the main removable components of the stove

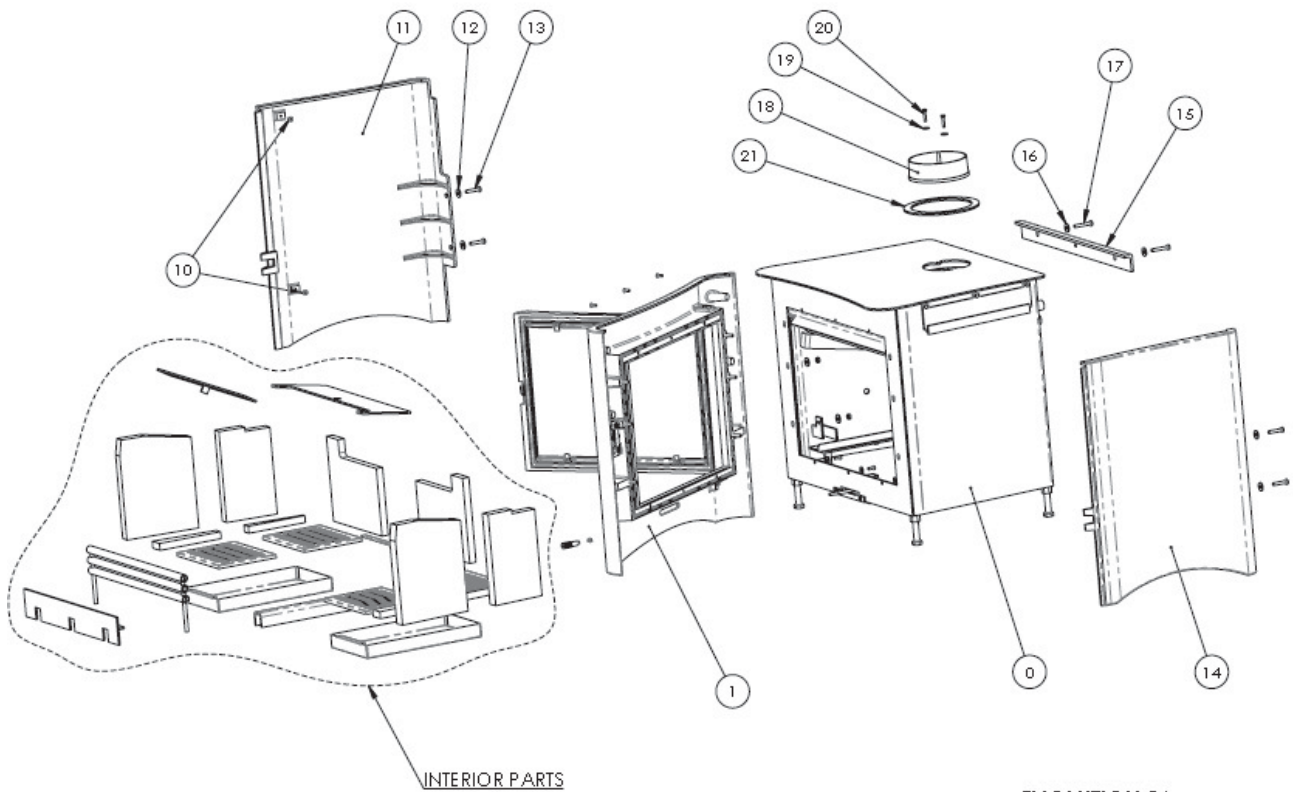

EVOLUTION 26
assembly 2

It is possible to remove these components for transportation.

Front Casting Assembly:

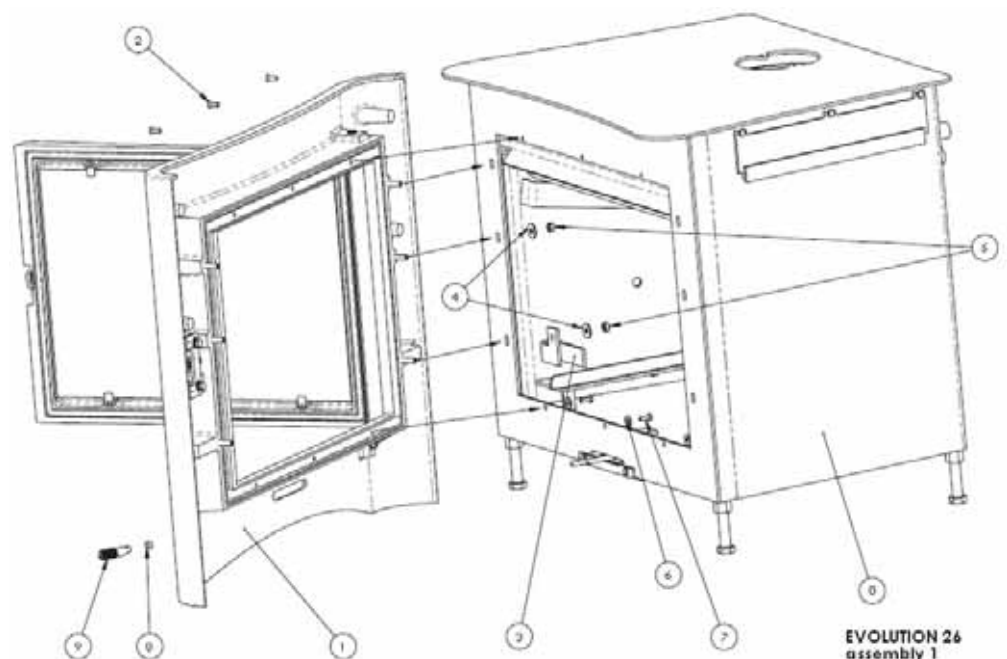

EVOLUTION 26
assembly 1

Assembly

Installing/removing the internal firebricks

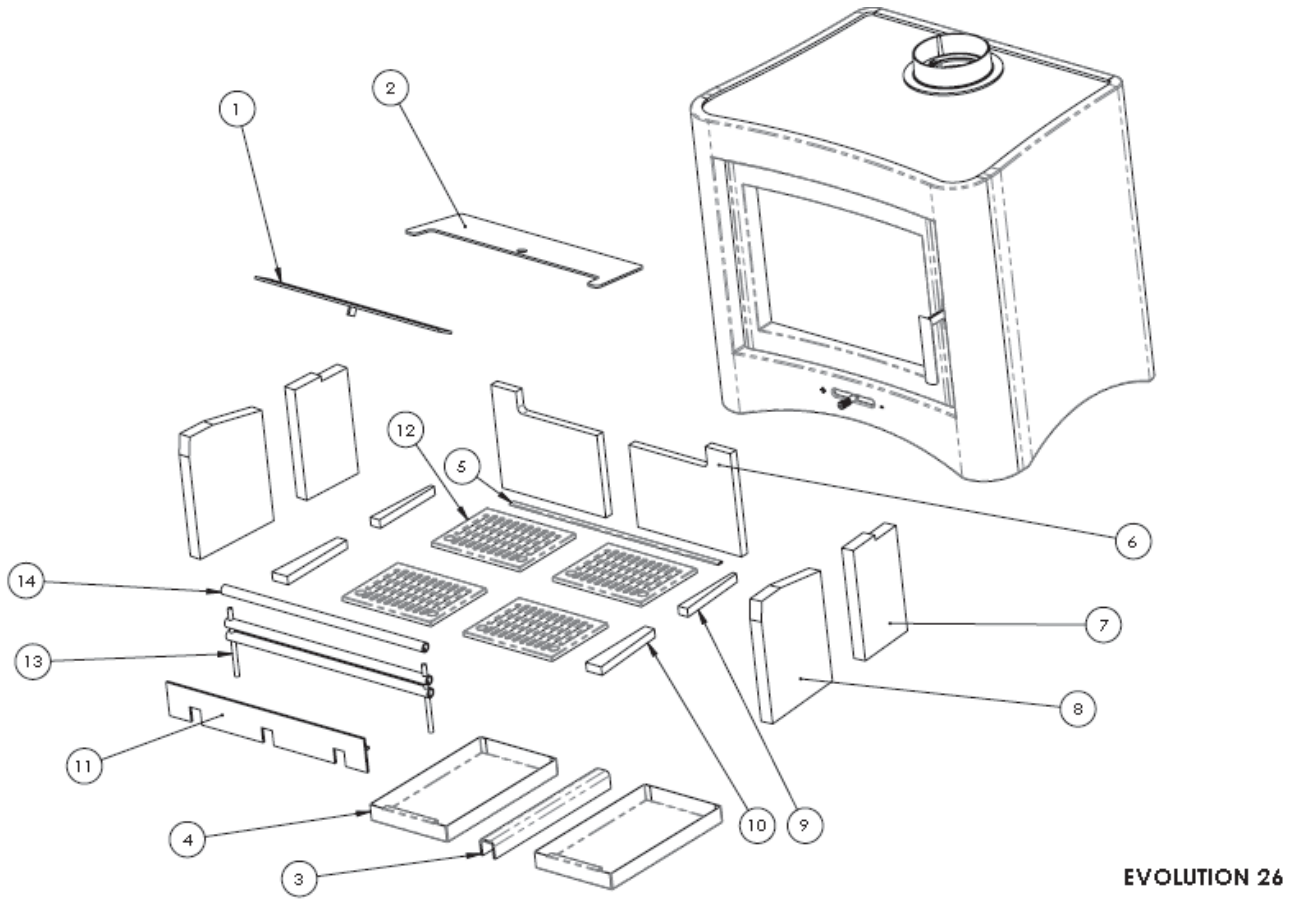

To install these components simply follow the numbered sequence 1-14, to remove simply reverse the sequence.

Please note that Item 2 is an additional baffle that is NOT required for installations in the UK and the Republic of Ireland and should be removed entirely (If not already removed). Item 5 is rope which sits underneath the rear firebricks (item 6).

Assembly

When installing this appliance into a smoke control area you will need to change the clip that is attached to the rear of the air slider for the smoke exempt clip (supplied). The smoke exempt clip ensures a constant supply of combustion air to meet smoke exempt requirements.

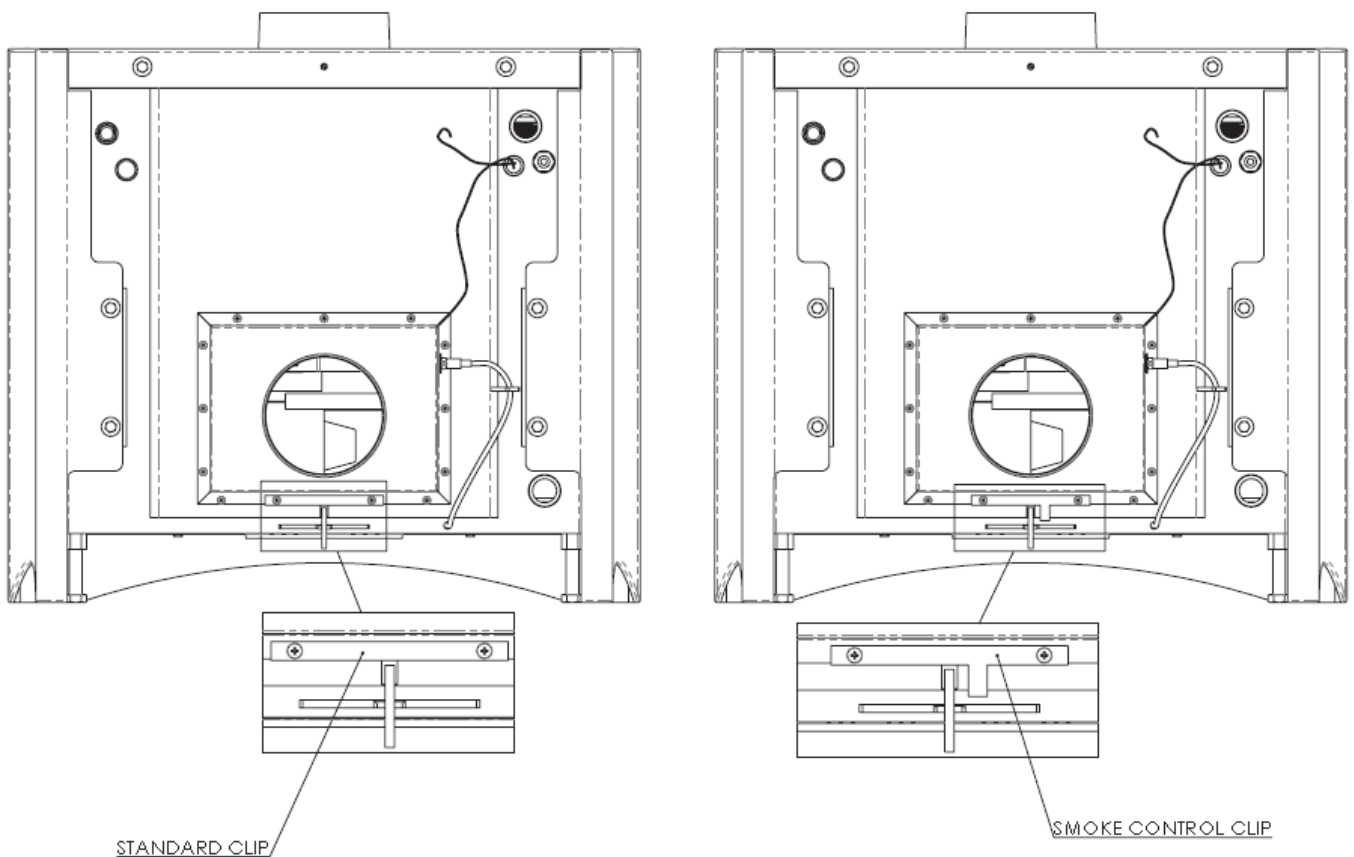

FOR MODELS MANUFACTURED PRE 2013 THE AIR SLIDER WILL COME PRESET FOR SMOKE EXEMPT AREAS. FOR INSTALLATIONS **NOT** IN SMOKE CONTROL AREAS YOU WILL SIMPLY NEED TO REMOVE THE RETAINING SCREW WHICH OTHERWISE PREVENTS THE SLIDER FROM FULLY CLOSING.

Plumbing Advice

Boiler installations should only be carried out by qualified heating engineers who hold a HETAS wet systems certificate or equivalent. Installations incorporating the SCWS (Safety Cold Water System) should ONLY be carried out by those engineers who have completed the SCWS training course or an equivalent Biomass training course.

If connected to an unvented heating system, this appliance must (as a minimum) have the following components installed on the system to ensure the safe operation of the appliance:

- 1) WATTS STS220 – Thermal discharge Valve (supplied)
- 2) WATTS KSG 30 – Safety Pressure Relief Valve (supplied)
- 3) Expansion Vessel comprising 7% of the total system volume (not supplied)
- 4) If connected in conjunction with a Gas Combination Boiler you will need a “Low Loss Header” to link the boilers together; this will ensure that there is no conflict between the two boilers. The low loss header should be sized and provided by the heating engineer.

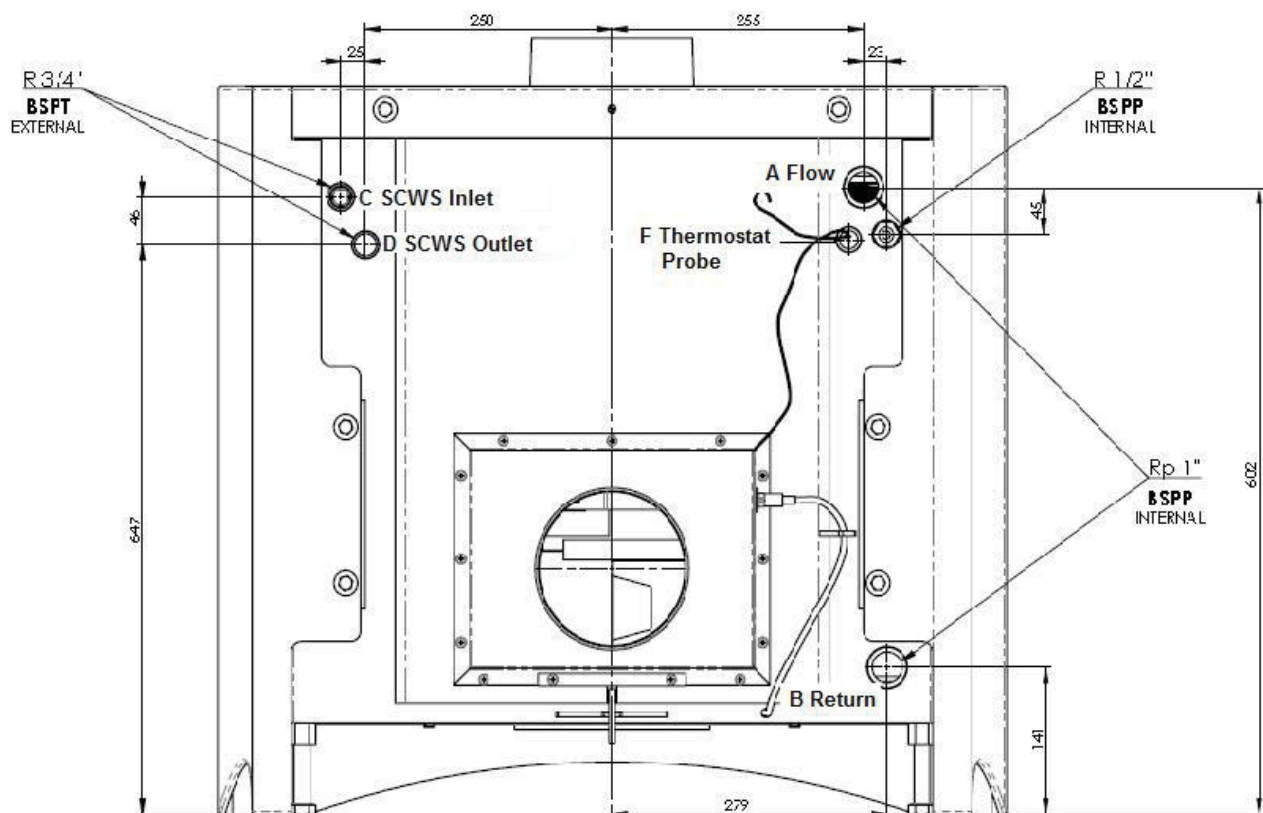

Plumbing Advice

The eVolution 26 Stove differs from normal boiler stoves in the fact that it can be installed on an open vented or sealed/pressurised heating system. When installing the appliance on a sealed system, it is necessary to install added safety features which allow the stove to be installed safely.

The eVolution has several options regarding water circuit safety. The components used, and why each is required, are detailed below.

DESCRIPTION OF SAFETY COMPONENTS

SCWS

The SCWS prevents the boiler reaching 100°C. This works by transferring the heat in the boiler away through a secondary quench coil situated inside the boiler. The quench coil is activated by a thermal safety valve (Watts STS20) which activates at 97°C. The thermal safety valve needs to be connected to mains water and drained suitably through an outside wall, in accordance with G3 regulations.

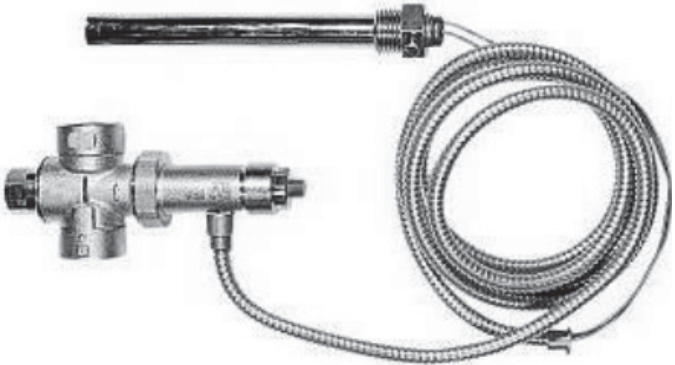

The Thermal Safety Valve needs to be connected to a mains water supply and then to the quench coil in the boiler. Both openings are 3/4 inch female connections. There should be a minimum pressure of 1.5 bar mains water supply to the SCWS. The maximum operating pressure is 8 bar.

IF YOU CANNOT GUARANTEE A SUITABLE WORKING PRESSURE THEN THE APPLIANCE SHOULD NOT BE INSTALLED

The discharge from the safety coil needs to be discharged through an outside wall and terminated at a low level within a 100mm through a metal pipe that naturally drains. The discharge pipe should be in accordance with G3 regulations. The thermal safety valve probe needs to be inserted into the tube and 1/2 inch tapping in the rear of the boiler.

To ensure correct operation of the thermal safety drain over the long-term, periodic drainage of the valve is required (at least once a year); to perform such operation, press the red discharge button located at the top of the valve head. Such operation allows cleaning the seal seat where foreign particles build up. After a certain number of periodic cleaning operations, it is advisable to replace the valve plug which is supplied as spare part.

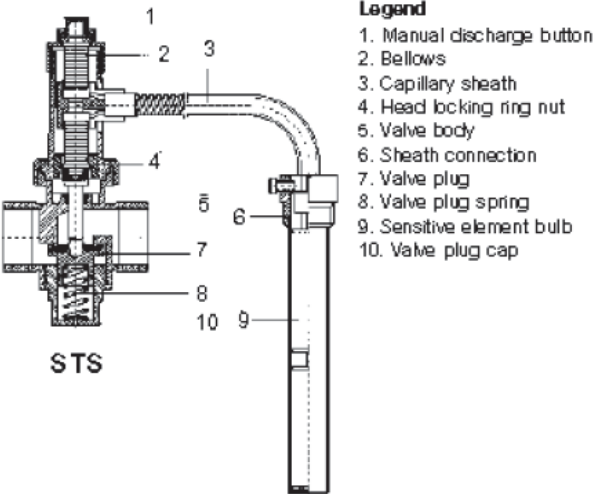

Plumbing Advice

Safety blow off

The safety blow off valve acts as a final safety option in case of failure of the SCWS. This is supplied incorporating a 3bar pressure relief valve, a pressure gauge and an automatic air vent. This must be placed within 1 meter of the appliance.



The safety blow off discharge pipework should will be 28mm pipe work

N.B. the use of a quench coil does not affect the primary system volume and therefore allows the system to recover and resume normal operation when the boiler has cooled adequately. The use of the pressure blow off however will reduce the primary water volume and drop the system pressure this will require the system to be refilled and checked before it can be used again. Running a boiler without water in it can damage the appliance and pumps allowed to run without water in them will quickly overheat and fail.

Back end protection

The back end protection is a three-way valve (regulated by temperature) that improves the efficiency of the boiler, reduces condensation and actively prolongs the longevity of the boiler. It does this by not allowing cold water from the heating system to be directly introduced into the boiler until a desired temperature is reached, in this case 55 °C.



The valve used is an ESBE VTC511 or equivalent.

- Improves efficiency by not robbing heat from the fire.
- Reduces boiler condensation and prolongs the life of the boiler by not allowing water from condensation to mix with smoke particles potentially creating harmful acids and toxins which can have detrimental effects on the boiler.
- Helps reduce tarring inside the appliance and flue

Tarring may also result from burning wet wood with a moisture content greater than 20%

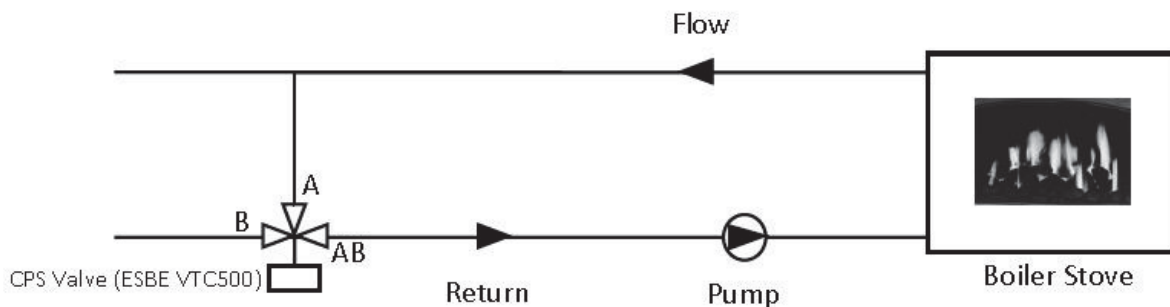

Plumbing Advice

Expansion vessels

The boiler must be directly connected to the expansion vessel in the system using a pipe with a diameter no smaller than 18mm. The piping must not be obstructed in any way. The expansion vessel must be at least 7% of volume of the total heating system. The expansion vessel should be fitted on the suction side of the pump. The point at which it is fitted is generally accepted as being the neutral point of the system. An expansion vessel is divided into two compartments and separated by a flexible diaphragm. The sealed side is charged with nitrogen gas. The open side is connected to the system.

Sizing of an expansion vessel:

Sizing of an expansion vessel is very important as the expansion vessel must be large enough to accommodate all the expansion of the water.

- The volume of water contained within the system. Manufacturers supply data which includes water capabilities of such things as boilers and heat emitters.
- Initial pressure of system, or pre-pressurisation, calculated from the static height which is the vertical distance from the expansion vessel to the highest point.
- The boiler flow temperature. Should the volume fall between two sizes, the larger size **must** be used. The volume of the expansion vessel in litres fitted to a sealed system shall not be less than that given by the table below.

Safety valve setting (bar)	3								
Vessel charge pressure (bar)	0.5				1			1.5	
Initial system pressure (bar)	0.5	1	1.5	2	1	1.5	2	1.5	2
Total water content of system	Expansion Vessel Volume (litres)								
25	2.1	3.5	6.5	13.7	2.7	4.7	10.3	3.9	8.3
50	4.2	7	12.9	27.5	5.4	9.5	20.6	7.8	16.5
75	6.3	10.5	19.4	41.3	8.2	14.2	30.9	11.7	24.8
100	8.3	14	25.9	55.1	10.9	19	41.2	15.6	33.1
125	10.4	17.5	32.4	68.9	13.6	23.7	51.5	19.5	41.3
150	12.5	21	38.8	82.6	16.3	28.5	61.8	23.4	49.6
175	14.6	24.5	45.3	96.4	19.1	33.2	72.1	27.3	57.9
200	16.7	28	51.8	110.2	21.8	38	82.1	31.2	66.2
250	20.8	35	64.7	137.7	27.2	47.5	103	39	82.7
300	25	42	77.7	165.3	32.7	57	123.6	46.8	99.3
350	29.1	49	90.6	192.8	38.1	66.5	144.2	54.6	115.8
400	33.3	56	103.6	220.4	43.6	76	164.8	62.4	132.4
450	37.5	63	116.5	247.9	49	85.5	185.4	70.2	148.9
500	41.6	70	125.9	275.5	54.5	95	206	78	165.5

Plumbing Advice

Alarms

It is not a requirement to fit an alarm on the system, but it is recommended. The alarm will act as a warning to the customer if the SCWS should operate. The alarm should be fitted to the SCWS discharge pipe and should register an increase in temperature when the SCWS is in operation. The customer should be notified that if this SCWS system/alarm is continually operating that measures should be taken to stop the overheating of the appliance. Measures to take are as follows:

- 1) Close all the air controls, including the tertiary and thermostatic air controls
- 2) Run hot water tap to remove some of the hot water in the cylinder (if fitted)

The customers should also be made aware that if there is constant operating of the SCWS, they should contact the installer to diagnose any problems with the system.

N.B. A boiler that is too large for the required heat load will trigger the SCWS too often and should therefore be replaced by a boiler that is better suited to the heating load.

It is mandatory to fit the safety components below when running a closed/pressurised system. Failure to install these components will void your guarantee and warranty, and risk the possibility of damage, to the extent of the boiler exploding.

Table of required safety components

Safety Component	Open Vented – Gravity	Open Vented - Pumped	Pressurised
SCWS	n/a	Mandatory	Mandatory
Safety Blow Off	n/a	n/a	Mandatory
Back End Protection	n/a	Recommended	Mandatory
Expansion Vessel	n/a	n/a	Mandatory
Alarm	n/a	Recommended	Recommended

Plumbing Advice

Plumbing the Appliance – Open Vented

This installation should be in accordance with BS 5449:1990 - Specification for forced circulation hot water central heating systems for domestic premises.

It must include a gravity circuit with an expansion tank open to the atmosphere. When installing this appliance on a gravity circuit, the system should consist of a tank/indirect cylinder fixed in an upright position and should be connected to the boiler by 28mm pipe (both flow and return). The pipes should not exceed 7.8m in length. The shorter the run of pipe work the more effective the appliance is going to be at heating the water. The cylinder and pipe work should be lagged to minimise the heat loss in the system.

A 'heat-leak' radiator must be incorporated into the system to dissipate any excess heat produced from the boiler when connected demands are low. The heat leak radiator must be sized at a minimum of 10% the boiler output. Fit the heat leak radiator in the gravity circuit using 22mm pipe reducing to 15mm for no more than 300mm before the radiator. When plumbing the appliance open vented you will need to cap the SCWS discharge pipe (D) but leave the SCWS flow uncapped (C) The SCWS probe hole will also need to be capped (E) as it is not needed. (Letters refer to diagram on page 13).

Plumbing the appliance sealed/pressurised system

When installing the appliance on a closed/pressurised system the safety components mentioned previously *MUST* be installed. Failure to do this could have very serious consequences and will void your guarantee and warranty. We have given some examples at the back of this plumbing advice on how the appliance can be installed in typical situations. These illustrations should be taken as a guide and not a definitive plumbing diagram. There is no requirement for a heat leak radiator on a closed system; we would however recommend installing one radiator that has no thermostat.

Link Up Systems

It is possible to link the eVolution stove to other boilers on a pressurised/closed system. This however can cause problems with 'conflicts' between the two boilers. Any solid fuel appliance with a boiler can be linked to an existing or new central heating system fired by another fuel or a second solid fuel appliance. This means that the central heating can be heated by one or both boilers in tandem, depending on the heat demand.

When linking two or more heat sources together on a sealed system there are a number of ways to do this, the easiest being via a low loss header.

A low loss header works on the same principals as a neutralizer on an open vented system. It is a simple method to connect two appliances at a neutral point in order that there is no hydraulic interaction between them. This means that the pumped circuit from a second appliance will not induce a flow through the solid fuel boiler.

Plumbing Advice

Timer control of a system with a woodburning boiler appliance

As wood burning appliances are not automated, and can therefore not be ignited, controlled and extinguished by electrical control from a heating programmer it needs to be borne in mind that any heat produced when the heating is not being called for must be able to be dissipated in order to negate unnecessary triggering of the safety devices. The use of a thermostat on the low loss header that runs the CH pump (and opens the appropriate motorised valves) when there is heat to be distributed is therefore necessary. There should be provision made on the heating system to ensure that enough radiators (or under floor heating zones) are permanently open and **NOT** thermostatically controlled to allow at least 20% of the wood boilers nominal output.

In installations that only use a wood boiler and therefore have no low loss header a high limit stat should be fitted to the flow from the boiler, set to ensure that the open circuit can dissipate at least 20% of the nominal boiler output

Thermal Stores

An alternative way to link up different heat sources is through a Thermal Store; this can link many appliances together and offers the best storage solution for any hot water produced. Using a thermal store also allows for the option of linking in solar heating with your system if required. Typical installation guides for link up systems can be found in the diagrams at the back of this plumbing advice section.

Checks on Initial Firing

Before connecting up the boiler, the installer must ensure that they thoroughly flush all of the system's pipes in order to remove any residue which could compromise the correct operation of all system components (pumps, valves etc). It is also important to verify that the chimney has sufficient draught, there are no blockages and that no other appliance exhausts are inserted into the flue.

Inform the householder of the safety systems fitted to this stove. Explain the necessity to maintain the water supply to the SCWS (cooling loop).

Filling up the System

Once all connections are complete, the installer can proceed with the boiler connection. Open all the vent pipes of the radiators, the boiler and the system. Gradually open the load valve, ensuring that the air vent pipes are working correctly. Use the gauge to confirm the system is pressurised. With closed tank systems, a pressure of 0.11 – 0.12 MPa (1.1 – 1.2 bar) must be reached.

Plumbing Maintenance

It is essential that your stove is well maintained and annually serviced by a qualified professional to ensure it's continued efficient operation. Failure to maintain and service your appliance as laid out in these instructions will result in the voiding of your products warranty. Please see section "Maintenance" for information on annual servicing of the stove and its internal components.

Plumbing Servicing

It is critical that all aspects of the SCWS (Safety Cold Water System) are annually checked to ensure correct operation. The main safety valve in the SCWS is the Watts STS20 valve, which will open to allow mains cold water to enter the boilers quench coil. It is necessary to clean the valve to remove impurities and deposits before initial firing and during servicing of the installation. To activate the manual discharge and therefore the cleaning, press and hold the red button on the valve, this will allow water to flow through the valve removing the deposits. The manual test of this valve **MUST** be performed at the annual service.

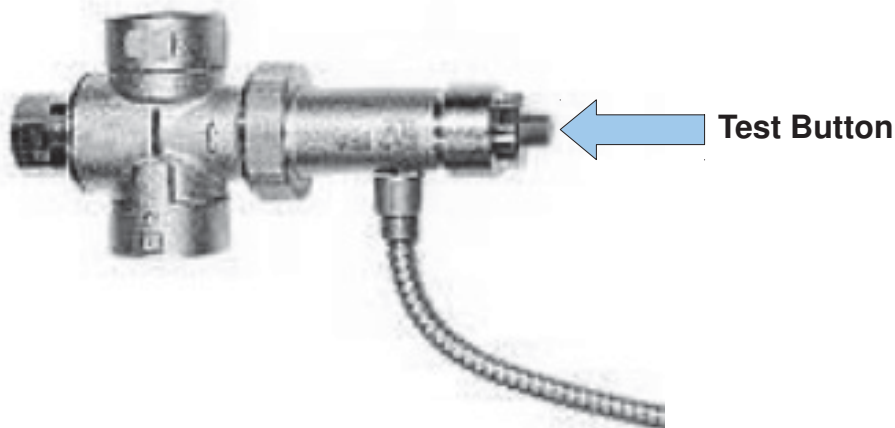

Plumbing Diagrams

We have given some example plumbing layouts of how the appliance can be installed in typical situations; these diagrams should be taken as a guide only and not as a definitive instruction. It is the sole responsibility of the plumbing and heating engineer carrying out the installation to design the system to suit the property and the clients needs.

The following diagrams are offered as a guide to assist in system design:

Diagram A

Pressurised boiler stove linked with combination gas boiler via a low loss header

Diagram B

Pressurised boiler stove linked with a non combi gas or oil boiler via a low loss header and the addition of an open vented hot water cylinder.

Diagram C

Pressurised boiler stove linked with a non combi gas or oil boiler via a low loss header and the addition of a pressurised hot water cylinder.

Diagram D

Pressurised stove linked with a non combi gas or oil boiler via a thermal store with solar for summer time domestic hot water

Diagram E

Pressurised boiler stove linked with a non combi gas or oil boiler via a thermal store with solar for domestic hot water and solar support for central heating system.

Diagram F

Stand alone pressurised boiler stove with an open vented hot water cylinder

Diagram G

Stand alone pressurised boiler stove with a pressurised hot water cylinder.

Diagram H

2 pipe open vented system

Plumbing Diagrams

Diagram A – Pressurised boiler stove linked with combination gas boiler via a low loss header

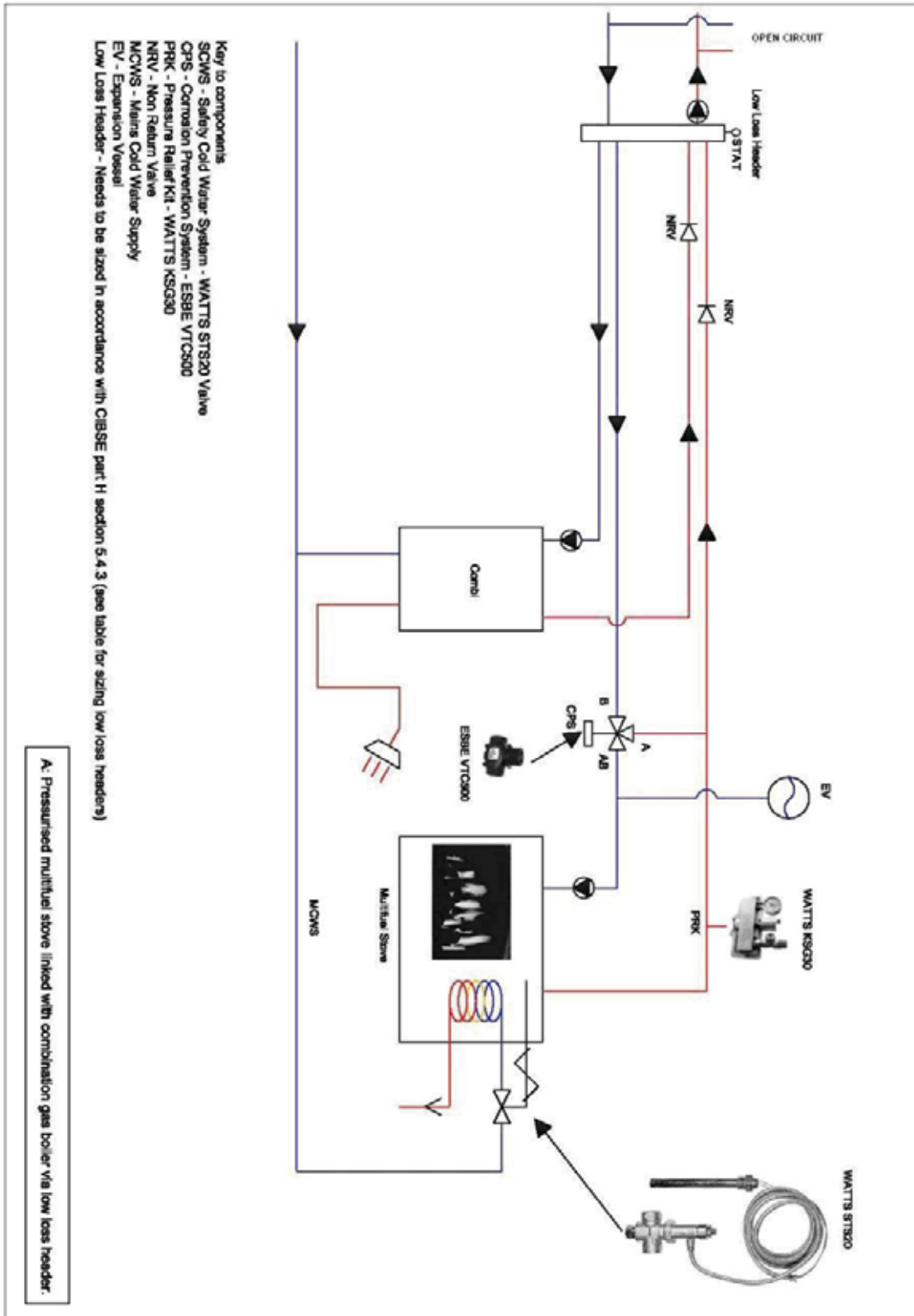

Plumbing Diagrams

Diagram B – Pressurised boiler stove linked with a non combi gas or oil boiler via a low loss header and the addition of an open vented hot water cylinder.

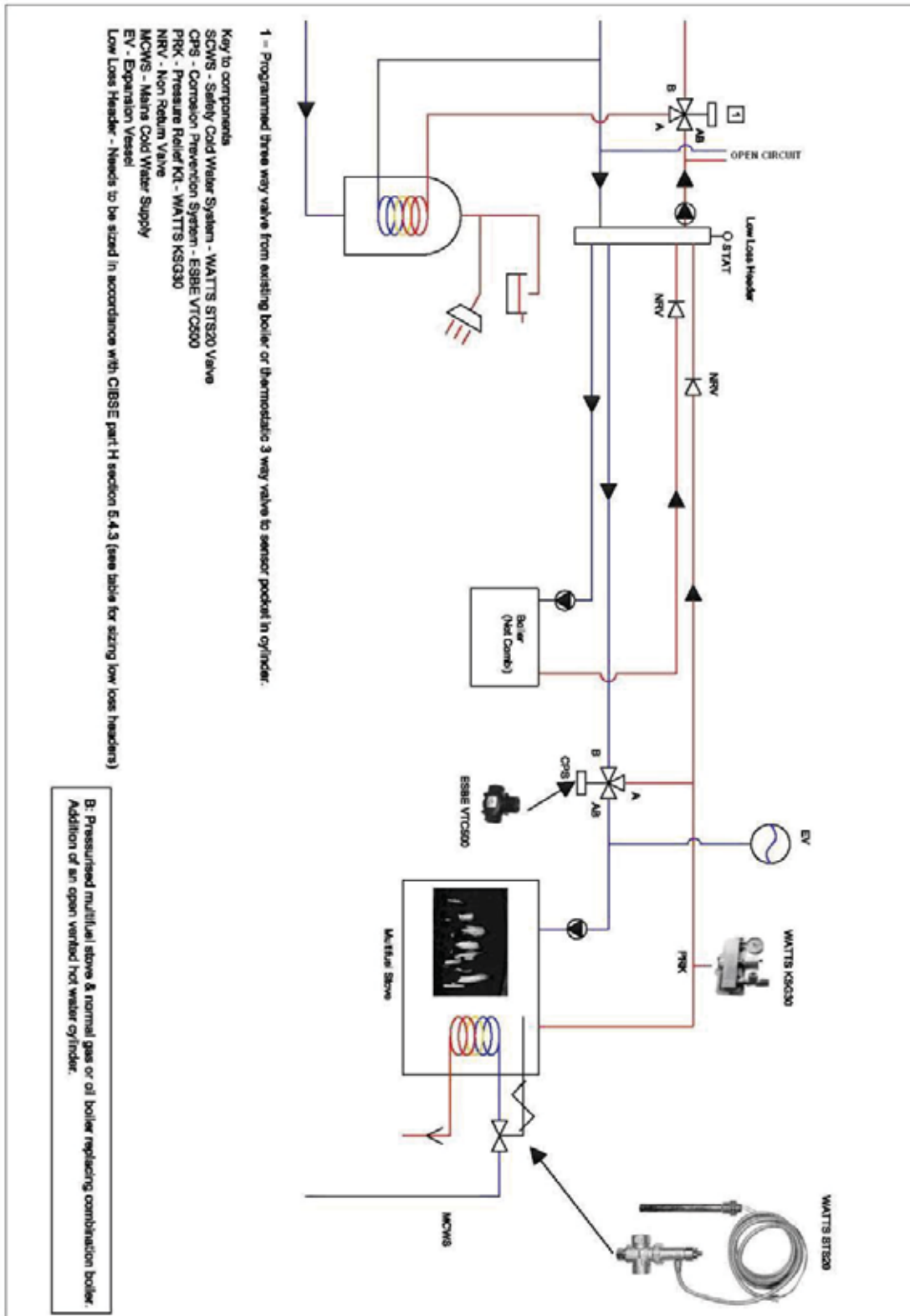

Plumbing Diagrams

Diagram C – Pressurised boiler stove linked with a non combi gas or oil boiler via a low loss header and the addition of a pressurised hot water cylinder.

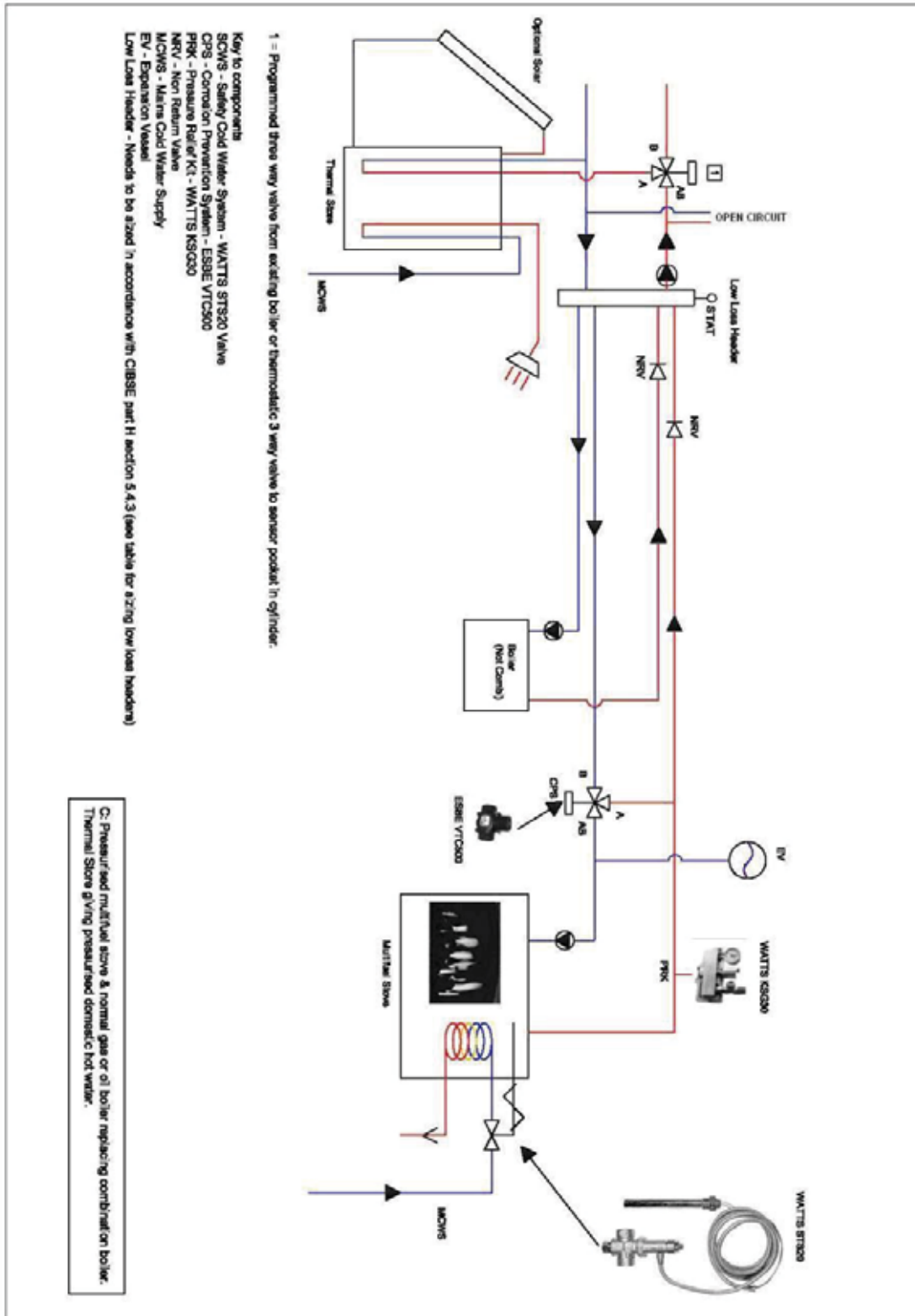

Plumbing Diagrams

Diagram E - Pressurised boiler stove linked with a non combi gas or oil boiler via a thermal store with solar for domestic hot water and solar support for central heating system.

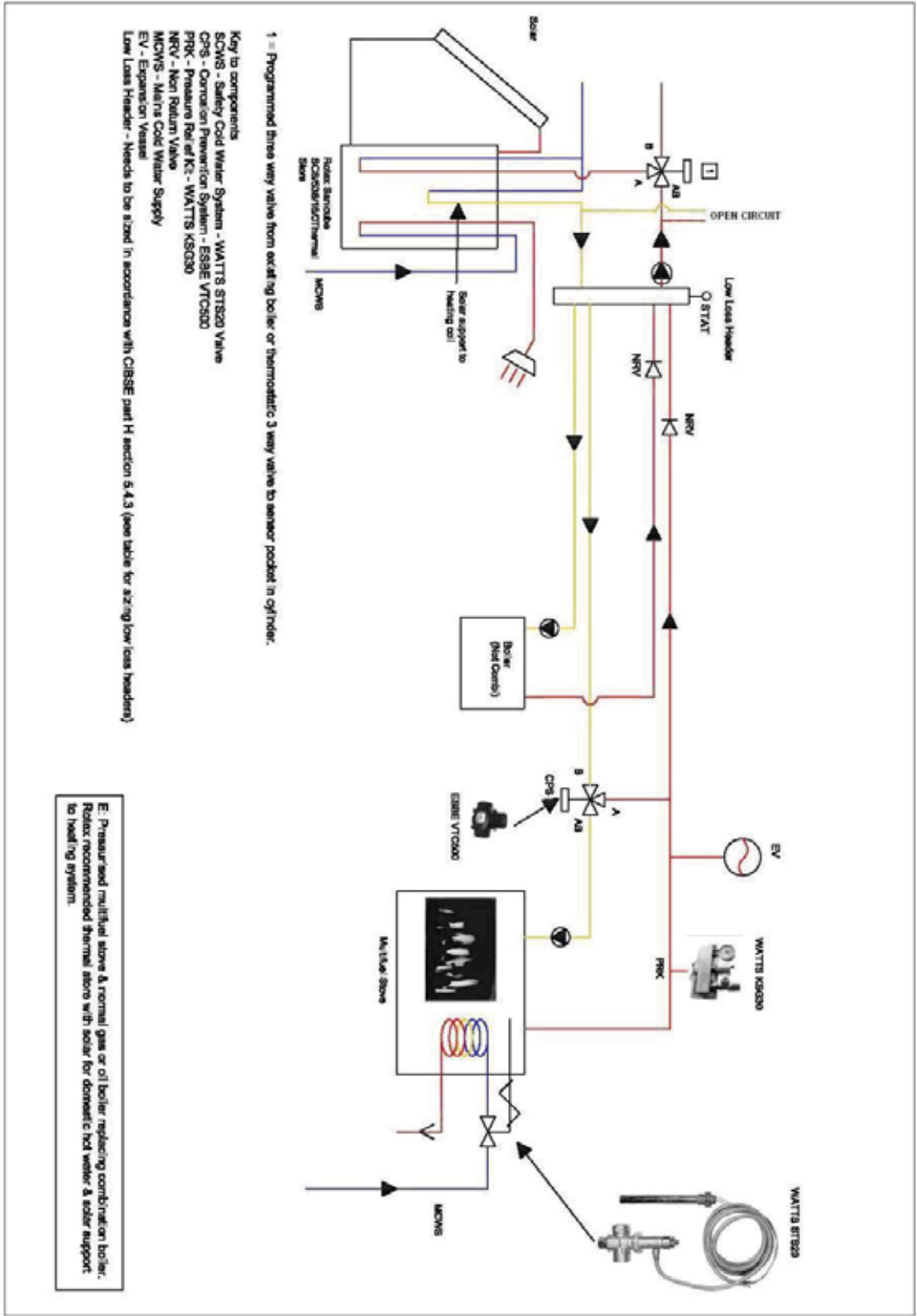

Plumbing Diagrams

Diagram F – Stand alone pressurised boiler stove with an open vented hot water cylinder

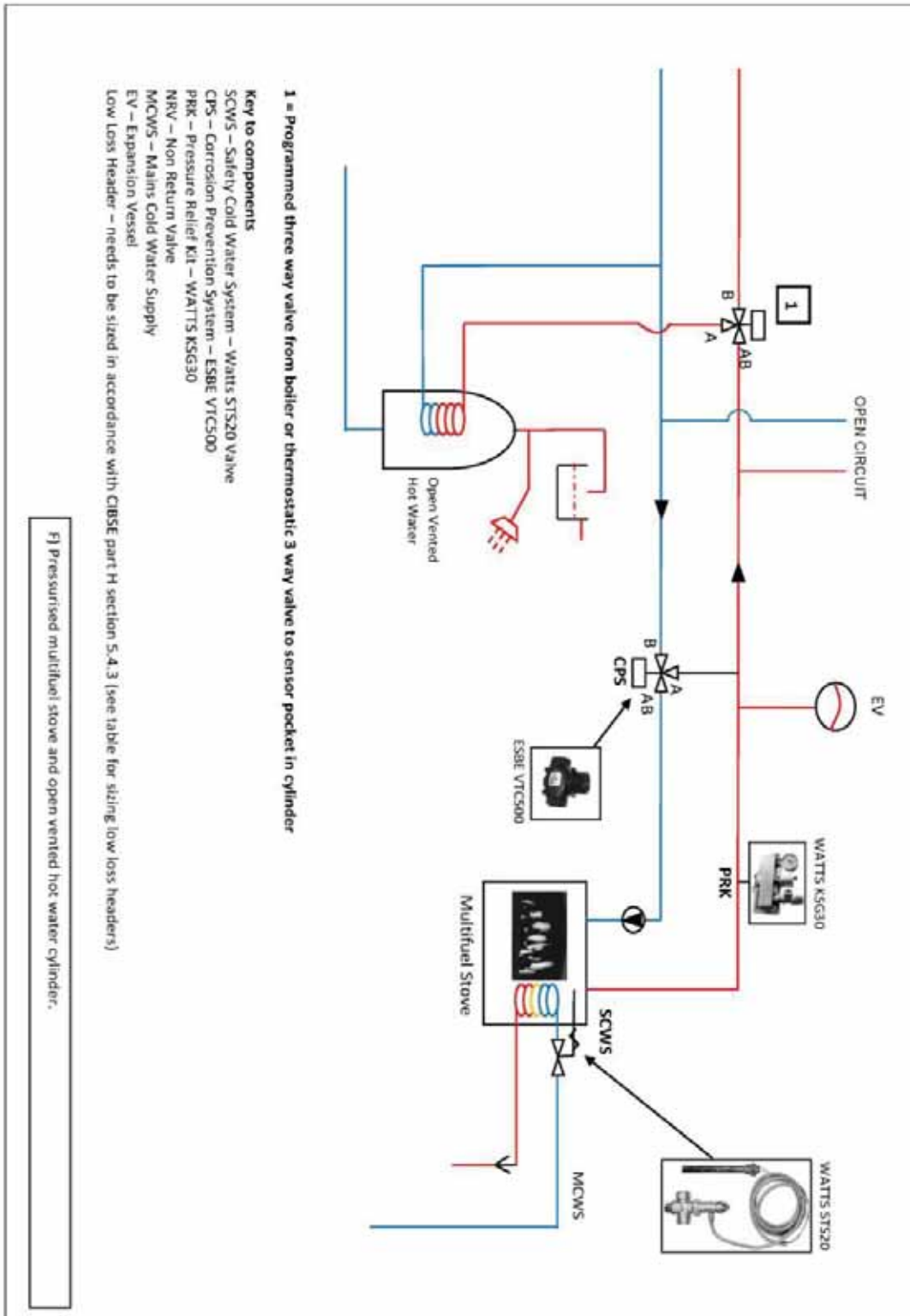

Plumbing Diagrams

Diagram G – Stand alone pressurised boiler stove with a pressurised hot water cylinder.

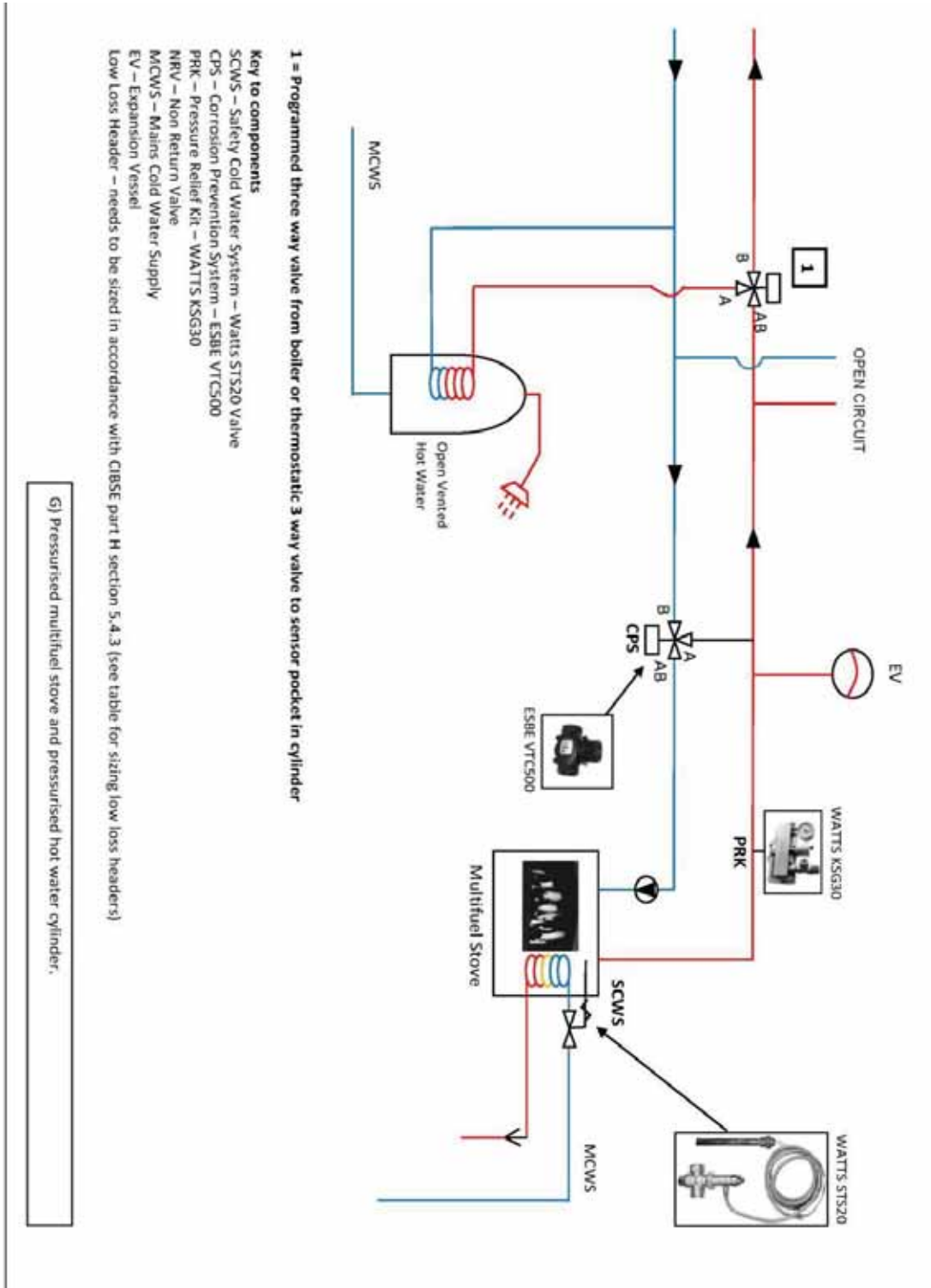

Plumbing Diagrams

Diagram H – Two pipe open vented circuit.

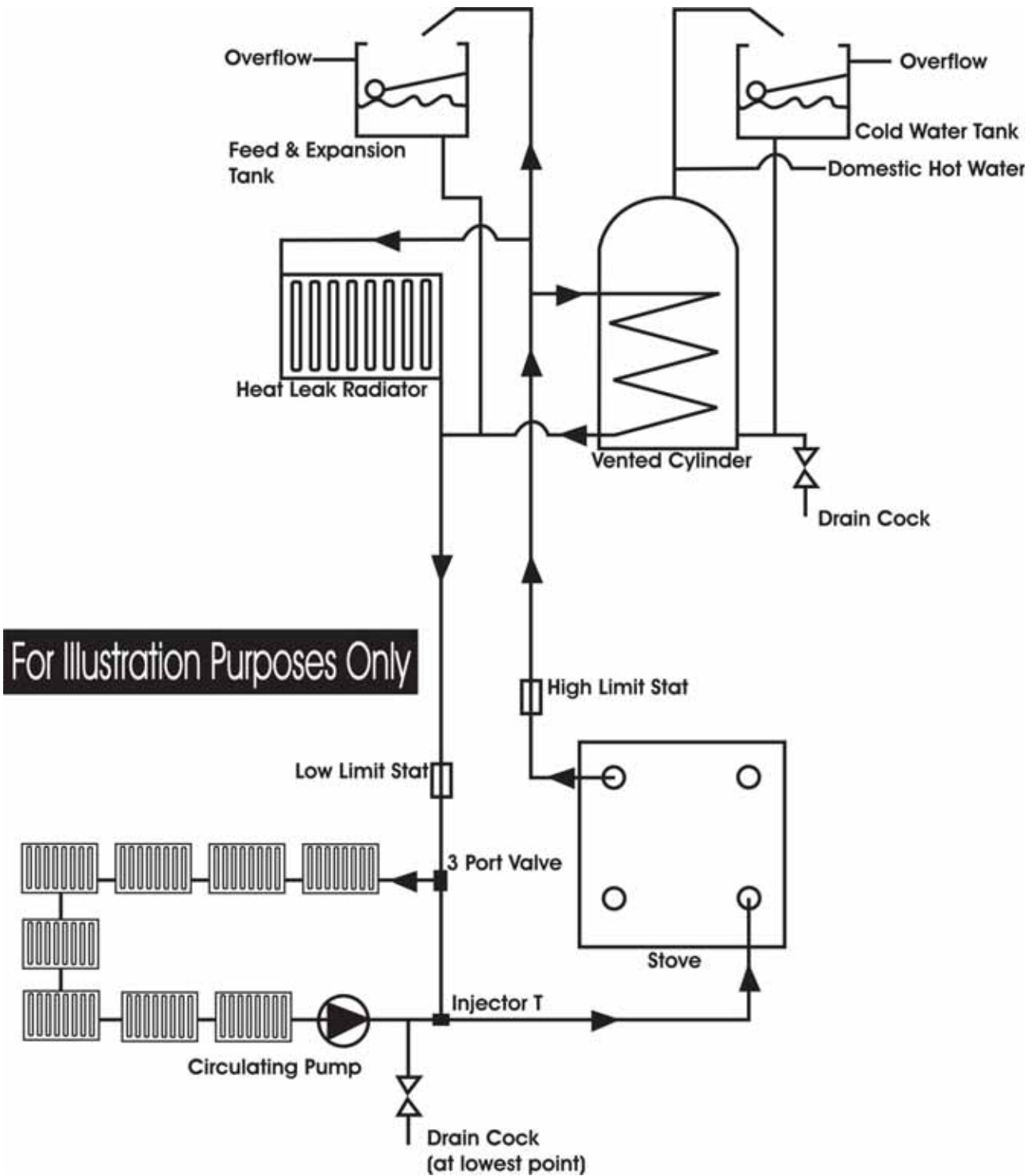



Commissioning & Handover

Ensure loose parts are fitted in accordance with the instructions for “Assembly” given previously. On completion of the installation, allow a suitable period of time for any fire cement and mortar to dry out; a small fire may then be lit and checked to ensure the smoke and fumes are taken from the stove up the chimney and emitted safely outdoors. Do not run at full output for at least 24 hours.

On completion of the installation and commissioning, ensure that this installation and operation manual for the stove is left with the customer. Ensure the customer is advised on the correct use of the appliance with the fuels likely to be used on the stove and warn them to use only the recommended fuels for the stove.

Advise the user what they should do if smoke or fumes be emitted from the stove. The customer should be warned to use a fireguard to BS 6539 in the presence of children, aged and/or infirm persons. Advise the user not to fit an extractor fan in the same room as the stove as this can cause the stove to emit fumes into the room.

Controls Layout

The diagram below shows the position of the air control, this control needs to be operated correctly to control the combustion rate of the stove.

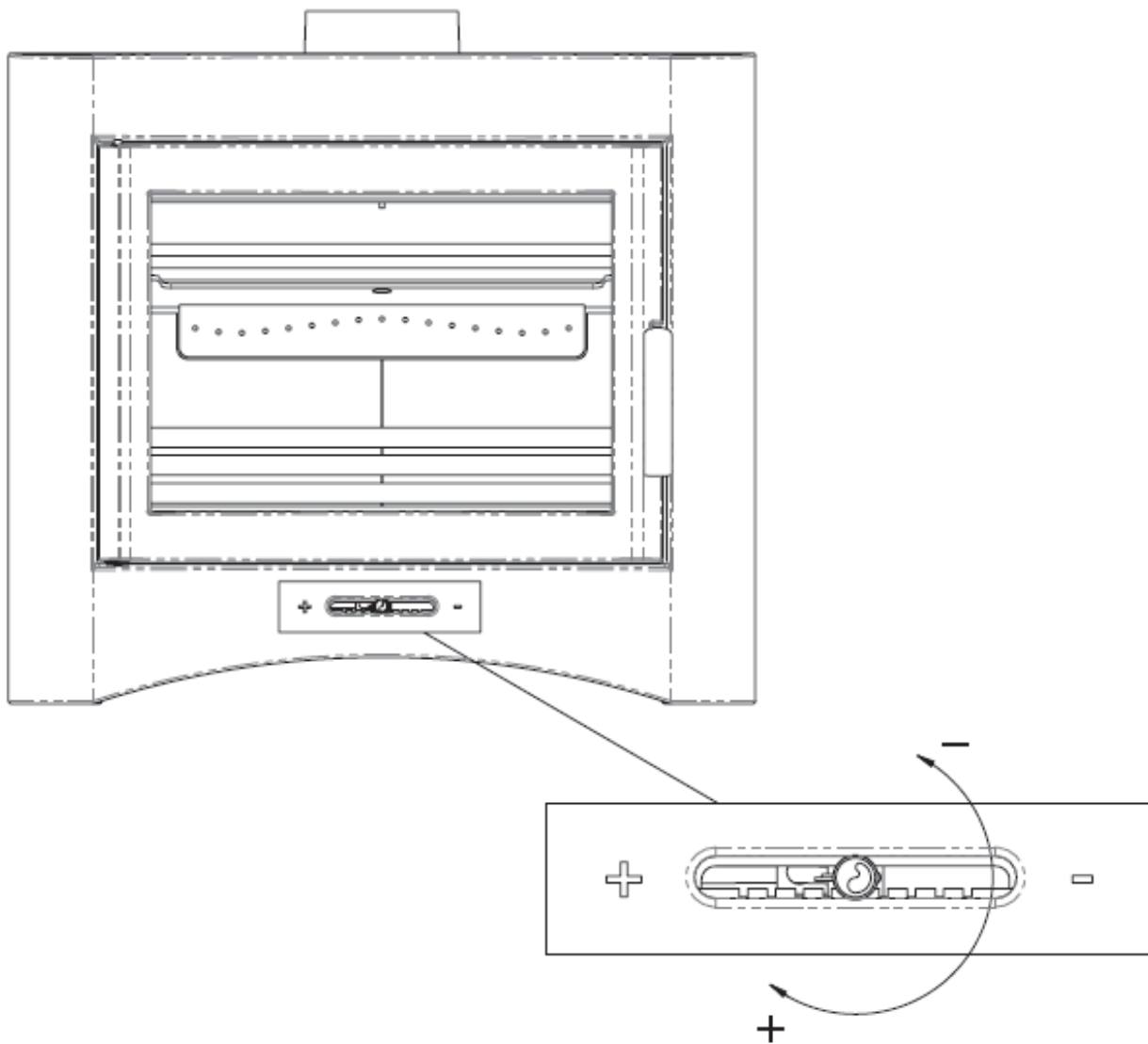

This air control is classed as the “**Secondary Air Intake**” as it brings air in above the grate. See the following section for a more detailed description of how this control works.

Controls Explained

Fire needs air to burn therefore the stove is fitted with an air control that allows you to regulate the amount of combustion air therefore controlling the burn rate within the appliance.

Secondary Air Intake

The secondary air intake is located on the front of the stove below the door, it is in the form of a slider. Having the slider pushed to the right indicates that the air intake is in the closed/minimum position and to the left indicates it is in the fully open/maximum position.

Air entering through this control is directed through the holes in the rear of the firebox and also down the inside of the glass creating the **AIRWASH** system – see below. The air wash system allows the glass to remain soot and particle free. This control is used at initial lighting and to control the burn rate of your wood.

The sections **LIGHTING THE STOVE & BURNING WOOD** give a step by step guide on how to operate this control.

Thermostat Control

This control is in the form of a dial which makes the end of the secondary air intake slider, located on the front of the stove. The thermostat provides an automatically regulated additional air intake. This air intake will close (cutting off the additional air supply) when the water temperature inside the boiler reaches 80 °c. Turning the dial fully clockwise indicates the control is completely open (maximum additional combustion air) and fully anti-clockwise indicates the control is closed (zero additional combustion air). This particular air intake is adjustable throughout the rotation of the dial. Please note this control will lock shut once the water has reached 80 °c (once the water temperature drops below this point you will be able to operate the control again).

Air wash System

Air wash is a system where secondary air is drawn into the stove (by combustion) through the secondary air control and is deflected down the back face of the glass, thus preventing the smoke coming into contact with the glass. It does not mean that you will never have to clean the glass, but substantially lengthens the periods between having to do so. The air-wash system works best when burning dry wood. Wet wood will produce more deposits on the glass. Also, deposits will form on the back of the glass when the stove is operated on low heat for extended periods (where fuel is only just smouldering).



Recommended Fuels

This appliance has obtained approval from HETAS Ltd., for burning –

* Split Wood logs not exceeding 35cm in length and not over 20% moisture content.

Approval does not cover the use of other fuels either alone or mixed with the suitable fuels listed above.

Do NOT burn wet wood, This will give a poor heat output and will cause heavy deposits of soot and tar to accumulate on the glass and throughout the stove and flue. Tar and soot build-ups will also insulate the boiler causing poor heat transfer to the water, the coating of soot and tar in the chimney is volatile creating a high risk of chimney fires. A growing tree contains a high percentage of water, the wood needs to be dried out (seasoned) before it is suitable for burning (this can take several years). Wood logs are best stored in a stack, sheltered from the weather, in a well ventilated area and raised off the ground. This allows the air to circulate and prevents mildew.

Do NOT burn pallet Wood, or any other wood that contains glue, paint or any other chemicals. Burning such fuels may result in damage to the appliance. Any such damage will not be covered by the manufacturers warranty.

Lighting the Stove

Curing

On initial firing you will notice a very pungent odour, this is caused through the curing of the paint, we recommend starting with short burning sessions (with smaller quantities of fuel) and build up gradually to allow the components of the stove to settle. Opening doors and windows will allow the paint curing odour to dissipate and to allow ventilation into the room. Curing times can vary but typically should take around 8-12 hours (operation at high output) to complete.

Kindling

Stage 1

With the Secondary air intake slider (below door) in the fully open position and the door open, start your fire using twists of newspaper (or scrunched up balls) or firelighters. Form a bed on the grate using the newspaper, then add a generous amount of dry kindling onto the newspaper. Ensure there is sufficient air gaps between the kindling (a criss cross or pyramid style pattern is ideal to accomplish this).

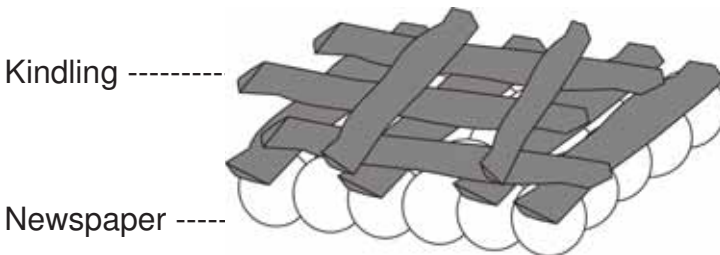

Stage 2

Ignite the paper underneath using a match or suitable fire-lighter. Allow the paper and kindling to burn until it reduces down into hot embers. If the fire is dying during this stage the door can be closed but not latched leaving a small gap for extra combustion air.

Stage 3

Add another generous load of dry kindling and allow to burn down.

It may be necessary to repeat stage 3 if the chimney is cold or if you find you have smoke entering the room. This stage is vital for getting heat into the chimney which will create the draw that takes the smoke away, we would expect this stage to take between 15-20 minutes.

It is critical that you do not leave the stove during the entire lighting and kindling stage. See Burning wood section for the next steps in the sequence.

Burning Wood

Once you have kindled your stove (see previous page) and your chimney (flue) is sufficiently heated and a large base of burning embers is present, you are ready to start adding you logs.

Stage 4

Place 1-3 small logs onto the bed of hot embers using the gloves provided, close the door but leave the Secondary Air Control in the fully open/maximum position. Allow the logs time to fully ignite and turn black.

Stage 5

Once the smaller logs have burned down you can now add 3-5 larger (or full size) logs. Leave the controls fully open until the new fuel turns completely black. You can now close down the Secondary Air Intake as required. You can now control the burn rate of the stove using the secondary air intake and thermostat. You are looking for a controlled flame (not smouldering in the embers or licking around the lid) this is mostly visual although a flue pipe thermometer will help you determine the amount of air required and is recommended for the initial lightings.

Stage 6

Refuel as and when required. It is important to open the controls fully prior to any refuelling. Take care to open the door gradually as flames may lick out and always use the gloves. Try to avoid closing the Secondary air control fully (as this will cause the stove to fill up with smoke) If you no longer want to keep the fire going simply allow it burn out.

It is important not to over load the firebox with large amounts of wood. The eVolution 26 has been certified and tested under the strictest CE conditions and will produce the nominal outputs by using 5.69Kg of wood per hour.

Below you will find 5.69Kg of wood pictured along with the ideal positioning of the wood when refueling.



Smoke Exempt Requirements

Under the Clean Air Act local authorities may declare the whole or part of the district of the authority to be a smoke control area. It is an offence to emit smoke from a chimney of a building, from a furnace or from any fixed boiler if located in a designated smoke control area. It is also an offence to acquire an "unauthorised fuel" for use within a smoke control area unless it is used in an "exempt" appliance ("exempted" from the controls which generally apply in the smoke control area).

The Secretary of State for Environment, Food and Rural Affairs has powers under the Act to authorise smokeless fuels or exempt appliances for use in smoke control areas in England. In Scotland and Wales this power rests with Ministers in the devolved administrations for those countries. Separate legislation, the Clean Air (Northern Ireland) Order 1981, applies in Northern Ireland. Therefore it is a requirement that fuels burnt or obtained for use in smoke control areas have been "authorised" in Regulations and that appliances used to burn solid fuel in those areas (other than "authorised" fuels) have been exempted by an Order made and signed by the Secretary of State or Minister in the devolved administrations.

The eVolution 26 has been recommended as suitable for use in smoke control areas when burning wood logs.

Further information on the requirements of the Clean Air Act can be found here :

<http://smokecontrol.defra.gov.uk/>

Your local authority is responsible for implementing the Clean Air Act 1993 including designation and supervision of smoke control areas and you can contact them for details of Clean Air Act requirements

Refuelling on to a low fire bed

If there is insufficient burning material in the firebed to light a new fuel charge, excessive smoke emission can occur. Refuelling must be carried out onto a sufficient quantity of glowing embers and ash that the new fuel charge will ignite in a reasonable period. If there are too few embers in the fire bed, add suitable kindling to prevent excessive smoke

Fuel overloading

The maximum amount of fuel (per hour) for this appliance is 9kg you should not exceed this figure, overloading can cause excess smoke.

Operation with door left open

Operation with the door open can cause excess smoke. The appliance must not be operated with the appliance door left open except as directed in the instructions.

Dampers left open

Operation with the air controls or dampers open can cause excess smoke. The appliance must not be operated with air controls or dampers door left open except as directed in the instructions

Warning Notes

Over-Firing

It is extremely important that you do NOT leave the air control in the fully open position for extended periods or run the appliance with the door open. Leaving the air control fully open (or running with the doors open) will lead to “over-firing”. Over-firing is caused when too much heat is generated within the fire chamber, this will lead to warping, buckling and general damage to the stove and its internal components. Over-firing can also be caused by an excessive flue draft.

PLEASE NOTE ANY DAMAGE TO THE APPLIANCE CAUSED THROUGH OVER-FIRING WILL NOT BE COVERED BY THE WARRANTY.

Fumes

Properly installed, operated and maintained, this appliance will not emit fumes into the dwelling. Occasional fumes may occur whilst de-ashing and re-fuelling. However, persistent fume emission is potentially dangerous and must not be tolerated. If fume emission does persist, the following immediate actions should be taken:-

- a) Open doors and windows to ventilate the room
- b) Let the fire go out or eject and safely dispose of fuel from the appliance
- c) Check for flue or chimney blockage and clean if required
- d) Do not attempt to relight the fire until the cause of the fume emission has been identified and corrected. If necessary seek expert advice

Firebricks

Vermiculite is an industry recognised robust fireproof material which is used by many stove manufacturers to produce internal firebox linings (firebricks). With care vermiculite firebricks will give many years of faithful service.

It is important that care is taken whilst refueling your stove in order to protect the internal vermiculite parts from premature failure.

Never throw or drop logs into your stove as this will potentially damage your firebricks and may also result in logs bouncing out of the appliance (creating a possible fire risk). Open the door an inch initially (allowing the fire to settle) then slowly open the door and gently place the log(s) onto the grate. Always use the glove (provided) when refueling to avoid the common scenario of dropping the logs in quick (because it's hot).

Take care when clearing the ash and using the poker tool not to strike and potentially damage your firebricks.

Always take care when removing the firebricks to avoid damaging them. It may be necessary to remove the firebricks during general maintenance and chimney sweeping.

Impact damage is the most common cause of cracked vermiculite firebricks; however it is also possible to crack the firebricks if you over fire your appliance.



Maintenance

It is essential that your stove is well maintained and annually serviced by a qualified professional to ensure it's continued efficient operation. Failure to maintain and service your appliance as laid out in these instructions will result in the voiding of your products warranty. Please see section "Plumbing Maintenance" for information on annual servicing of the plumbing aspects of the installation.

Ash Removal

The ash pans can be removed by lifting the 4 grates using the ash tool provided. We would recommend emptying the ash into a metal bucket for transportation.

You should only empty the ash when the appliance and ashes are completely cool and can be disposed of in your normal household refuse.

Chimney Fires

In the event of a chimney fire ensure the Secondary air control is fully closed and the door(s) remain closed at all times. If the chimney fire does not go out or if there is a serious risk to people and property, call the fire brigade immediately.

Regular sweeping of the chimney will remove combustible particles and will reduce the risk of chimney fires.

Cleaning the Stove

We recommend only doing this when the stove is cold using a soft brush to clean any of the stove surfaces, this is normally sufficient to remove dust, ash and debris. For stubborn marks you can use a damp lint free cloth, ensure that all surfaces are dried off immediately. We do not recommend using any kind of chemicals or abrasive materials. It is possible to touch up the paint using the original metallic black stove paint, however this new paint will then need to cure.

Glass Cleaning

A damp lint free cloth is normally sufficient, however for stubborn build ups we would recommend using a very fine wire wool.

Stove Servicing

Your stove should be inspected annually to ensure all seals are present and correct and to gauge the condition of the internal firebricks. The service should be done by a HETAS registered engineer who also perform a spillage test.

Maintenance

Chimney Sweeping

It is essential that your chimney (flue) is swept at least once a year by a registered professional chimney sweep. Sweeping removes particles that could otherwise fuel a chimney fire, it should also highlight any potential issues such as leaks and damage to the flue.

Flue ways and Boiler Cleaning

Cleaning of the flue ways and boiler is essential to get the best efficiency out of your boiler stove. The stove has an inspection/cleaning panel in the side of the stove as shown below. Ensure that there are no soot or tar deposits on the top of the boiler and, if there are, remove them by brushing the deposits into the fire chamber. Remove these using an ash vac or by means of the ash pan under the stove. This needs to be carried out at regular intervals throughout the year.

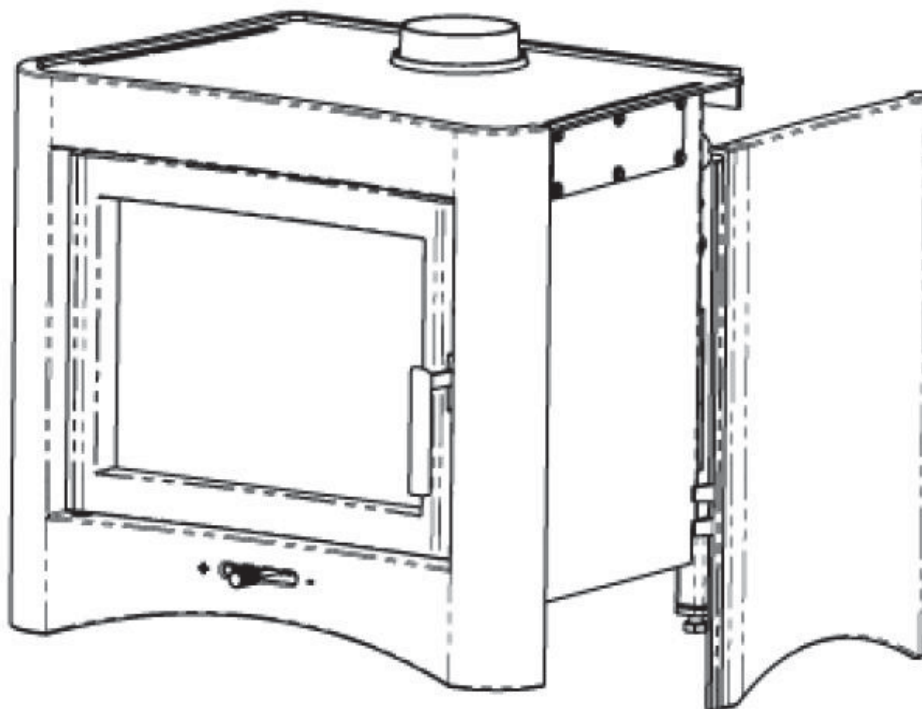

Trouble-shooting

Smoke comes out of the stove when the loading door is opened.

- The chimney cavity into which the 150mm flue pipe has been installed may be less than the minimum requirement.
- Deposits (soot or other obstructions) may have built up in the chimney and be restricting the flow of waste products. This flow rate is known as the 'draw'.
- Insufficient draw, this is especially common during milder weather. You will need to prolong the kindling stage to ensure the chimney (flue) is completely hot (you may even need to pre-heat the chimney using a method advised by the installer)
- Combustion air intake is not large enough or another appliance (e.g. Extractor fan) is taking air away from the stove.

The Stove does not produce the expected heat into the room.

- Has the flue pipe been sealed to the chimney to prevent heat being drawn up the chimney to waste?
- Green or wet wood is being burnt.
- The chimney has excessive draw (this is unusual). Seek installer advice with regard to installing a Flue Draught Stabiliser.
- The stove has been recessed into the existing fireplace and a lot of heat is being absorbed by the surrounding fireplace walls rather than being radiated into the room. Pull the stove forward.
- For the maximum efficiency of heat transference into the room the stove should be sited on the hearth of the fireplace rather than recessed.

The Stove burns too fast.

- Use whole logs rather than split ones.
- The wood being used may be generally too small.
- The "air-tight" seal between the fibre rope on the doors and the casting may have been lost, adjust door handle lock nuts to reinstate this seal or replace.
- The chimney has excessive draw (seek installers advice on this point).
- The fibre rope seal between the door and the glass may be leaking. Tighten or replace.
- The fibre rope on doors and glass has worn out. Replace.



Commissioning Form

Stove Purchased From: _____
 Address: _____
 Telephone Inc area code: _____
 Installation Date: ____/____/____ Stove Name: _____
 Product Serial Number: _____ Invoice Number: _____
 Stove installed by: _____
 Address: _____
 Telephone Inc area code: _____
 HETAS Registration Number: _____

Check-list

	Yes	No	n/a
Heat load of house inc. DHW			kW
Heat requirement for room in which appliance is to be installed			kW
Nominal boiler output to water			kW
Nominal appliance output to room			kW
Hearth to building regs.			
Chimney Flue Suitability			
Ventilation (permanent)			
Vent size			mm ²
Discharge Pipe Route			
Cold water main to boiler			
Flow & return routing			
Low loss header location			°C
Switched fused spur for pumps in boiler locale			
Availability of open circuit rads/UFH zones			
Output of above			kW
Designed system pressure			
Designed system volume			l
Designed expansion volume			l
Designed expansion pre-charge			bar
Flue draught measurement			mbar
Placement and orientation of Back End Protection			
Boiler Volume (wood burning)			l
Boiler Volume Existing gas/oil			l
Estimated system volume			l
Total system volume			l
Expansion volume			l
is this > 7% of total volume			
Expansion correctly sited and connected			
Smoke test of appliance and flue			
System water treated with inhibitor			
Thermal safety valve installed			
Double check valve installed			
No isolation from incoming main to Thermal Safety valve			



Commissioning Form

Check-list

	Yes	No	n/a
Thermostat to trigger solid fuel circulation pump installed			
Temp Solid Fuel stat set to °C			°C
Adequate drains in system pipe work to allow servicing			
Thermostat positioned on Low Loss Header			
Temperature Low Loss Header thermostat set at °C			°C
Pressure relief valve installed within 1m of boiler			
Audible alarm installed On SCWS?			
Availability of open circuit rads/ufh zones Y/N			
What % of boiler output			%
Are pipe runs free from potential air locks			
Are all pipes adequately lagged to within 1m of boiler?			
Is the expansion vessel at the correct pre charge			bar
Is the system at the designed pressure			
S/F Circulator pump fires when flue stat triggered			
C/H Pump fires when Low Loss Header stat triggers			
Does SCWS activate when circ pump off			
Does SCWS reseal quickly and quietly			
Does the stove installation comply with HETAS regs.			
Does the installation comply with Building regs.			
Is any electrical work compliant with Part P			
Does the heat from the stove get to the rads/ufh via the Low Loss Header			
Is the SCWS discharge pipe installed in accordance with Part G			
Is the PRV discharge pipe installed in accordance with Part G			
Is the flue compliant with Part J			
Is the data plate correct & installed			
Is the flue draught within the manufacturers tolerances			
Flue Draught reading			mbar/mm
Stove Controls Explained to End User			
Correct Fuels Explained to End User			
Manufacturers Clearances Adhered To			
Instruction Booklet Left With End User			
HETAS Certificate Left With End User			

Engineers
Signature: _____ Print Name: _____

Commissioning Date: ___/___/_____

Spare Parts

EVOLUTION 26

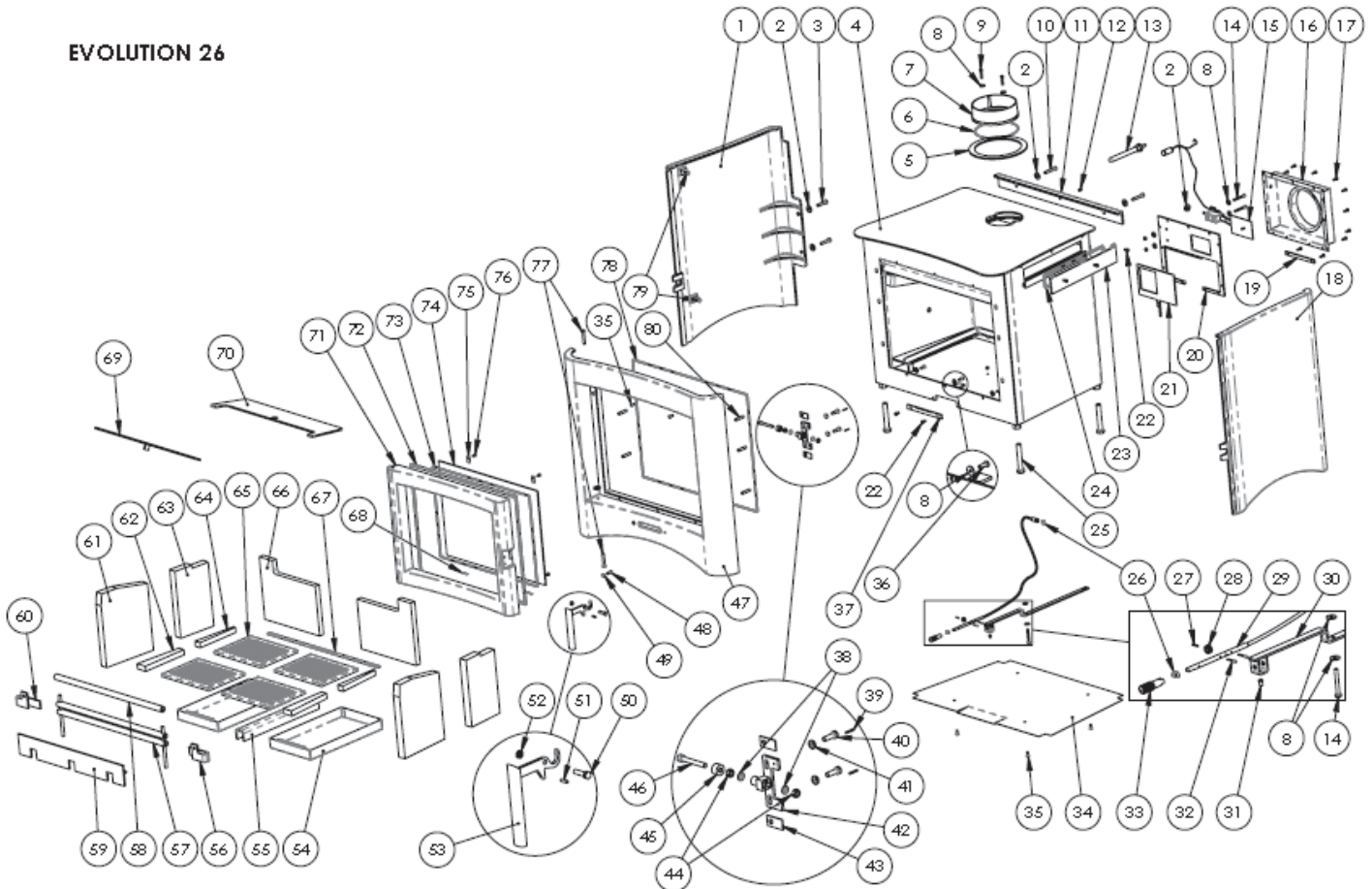

- (1) Left Side Casting (2) M8 Washer (3) M8 Bolt (4) Boiler Section (5) Spigot Ring (6) 8mm Rope
- (7) Spigot (8) M8 Washer (9) M8 Bolt (10) M5 Bolt (11) Rear Casting (12) M6 Grub Screw
- (13) Probe Sleeve (14) M8 Bolt (15) Thermostat (16) Air Box Assembly (17) M6 Screw
- (18) Right Side Casting (19) Smoke Exempt Clip (20) Slider Guide (21) Slider Flap (22) M6 Screw
- (23) Maintenance Cover (24) Rope 8mm (25) M6 Adjustable Leg (26) Spring Clip (27) Roll Pin
- (28) Rotation Clip (29) Flexible Cable (30) Slider Rod (31) M6 Screw (32) Roll Pins (33) Slider Knob
- (34) Base Deflector (35) M6 Screw (36) M8 Bolt (37) Slider Guide (38) Spring Washer (39) Roll Pin
- (40) M8 Bolt (41) M8 Washer (42) Door Latch (43) Spacer (44) M8 Nut (45) Latch Roller (46) M8 Bolt
- (47) Front Casting (48) M6 Screw (49) M6 Washer (50) M8 Bolt (51) Grub Screw (52) M8 Nut
- (53) Handle (54) Ashpans x2 (55) Ashpan Guide (56) Log Retainer Fixing Right
- (57) Log Retainer Bottom (58) Log Retainer Top (59) Front Log Guide (60) Log Retainer Fixing Left
- (61) Side Vermiculite x2 (62) Bottom Front Vermiculite x2 (63) Side Vermiculite Rear x2 (on latest version)
- (64) Bottom Rear Vermiculite x2 (65) Grates x4 (66) Rear Vermiculite x2 (67) 10mm Rope
- (68) 6mm Rope (69) Front Baffle (70) Rear Baffle (Germany Only) (71) Door Casting
- (72) 10mm Flat Rope (73) 6mm Rope (74) Glass (75) Glass Clip (76) Glass Clip Screw (77) Door Pins
- (78) 8mm Rope (79) Spacing Bolts (80) Threaded Bolts



EC Declaration



DECLARATION OF CONFORMITY

ACCORDING TO DIRECTIVES 89/106/EEC (CONSTRUCTION PRODUCTS)



ISSUED BY:	BROSELEY FIRES LTD KNIGHTS WAY, BATTLEFIELD ENT PARK. SHREWSBURY. SY1 3AB ph: +44 (0)1743 461444
-------------------	---

TYPE OF EQUIPMENT:	WOODBURNING BOILER STOVE
---------------------------	--------------------------

TRADEMARK:	BROSELEY FIRES LTD / eVolution
-------------------	--------------------------------

MODEL:	EVOLUTION 26 WOODBURNING BOILER STOVE
---------------	---------------------------------------

USE:	DOMESTIC HOT WATER AND SPACE HEATING
-------------	--------------------------------------

MANUFACTURER:	BROSELEY FIRES LTD KNIGHTS WAY, BATTLEFIELD ENT PARK. SHREWSBURY. SY1 3AB ph: +44 (0)1743 461444
----------------------	---

NOTIFIED BODY:	RRF Rhein-Ruhr Feuerstätten Prüfstelle GmbH
RRF 1625	Im Lipperfeld 34b D-46047 Oberhausen

The following harmonised standards and Technical specifications have been met and comply with good engineering practice and safety matters in force within the EEC

All CE standards or other documents	Initial Type Test Reports
	RRF-40 11 2595 DE RRF-40 11 2560

EN 13240	CE MARKING INFORMATION - See Instructions
-----------------	--

Particular/Smoke Conditions Exempt

As the Manufacturer's authorised representative established within the EEC, Broseley Fires Ltd Declare sole responsibility that the product for mentioned follows the provisions of the directives above.

09/01/2012 Shrewsbury UK
Place and date of issue



JOHN REEVES
Managing Director



Annual Service Record

1ST YEAR SERVICE completion date:

SERVICE ENGINEER: _____ REG. No. _____
 COMPANY NAME: _____
 COMPANY ADDRESS: _____

 CONTACT NUMBER _____ POSTCODE: _____

2ND YEAR SERVICE completion date:

SERVICE ENGINEER: _____ REG. No. _____
 COMPANY NAME: _____
 COMPANY ADDRESS: _____

 POSTCODE: _____

3RD YEAR SERVICE completion date:

SERVICE ENGINEER: _____ REG. No. _____
 COMPANY NAME: _____
 COMPANY ADDRESS: _____

 POSTCODE: _____

4TH YEAR SERVICE completion date:

SERVICE ENGINEER: _____ REG. No. _____
 COMPANY NAME: _____
 COMPANY ADDRESS: _____

 POSTCODE: _____

5TH YEAR SERVICE completion date:

SERVICE ENGINEER: _____ REG. No. _____
 COMPANY NAME: _____
 COMPANY ADDRESS: _____

 POSTCODE: _____

6TH YEAR SERVICE completion date:

SERVICE ENGINEER: _____ REG. No. _____
 COMPANY NAME: _____
 COMPANY ADDRESS: _____

 POSTCODE: _____



Warranty

This appliance must be installed and commissioned by a fully qualified, registered engineer. A "Declaration of completion Certificate" must be obtained for the installation and retained by the end user. Failure to comply with these requirements may void your warranty. You, as the end user, have a contract by law with the supplier / dealer from whom you purchased the product. That dealer then has the same contract with the manufacturer or wholesaler and these have a contract with their suppliers.

ALL CLAIMS MUST FOLLOW THIS PROCEDURE.

Thank you for choosing a Product from **Broseley Fires Ltd**. This warranty gives you specific legal rights. The statutory rights of the consumer are not affected by the warranty, or the consumers' rights against the dealer arising from their sales / purchase contract.

The manufacturers' warranty:

Your Product will be free from defective parts, material, and workmanship at the time of its original purchase for a period of five (5) years. This Warranty will become active as of one month from the date of delivery.

This warranty does not cover any failure of the unit due to normal wear and tear, misuse, abuse, accident, illegal modification, illegal installation or repair, damage resulting from improper use or failure to maintain the product. Variations in color and texture are a natural characteristic of cast iron products. Colour changes may result from exposure to light and other elements which are a part of the aging process. These material variations and changes are not covered by this warranty. If during the warranty period, this Product fails to operate under normal use and service, due to defects in material and / or workmanship, Broseley Fires will either repair or replace the product. The repaired or replaced product shall be warranted for the remaining period of the original warranty + the time taken to days from the date of repair, whichever is longer.

Repair or replacement may involve the use of functionally equivalent reconditioned units. Replaced parts or components will become the property of Broseley Fires.

Should you wish to claim under the warranty, please contact the supplier / dealer from whom you purchased the appliance. Do not claim directly to Broseley Fires, as they are unable to process any direct claim from an end user.

Product design and any specifications are subject to change without notice. This is due to our continuous product development and improvement. The buyer will not be entitled to request free upgrades to the new design or compensation for previously purchased products or any products on order.

- This Warranty covers all Broseley Fires costs within the Warranty period.

If the appliance remains uninstalled for a period greater than six months from date of delivery the Warranty will become active six months from the date of original invoice to the distributor.

IN NO EVENT SHALL BROSELEY FIRES BE LIABLE FOR INCIDENTAL OR CONCEQUENTIAL DAMAGES OF ANY NATURE WHATSOEVER, INCLUDING BUT NOT LIMITED TO LOST PROFITS OR COMMERCIAL LOSS, TO THE FULL EXTENT THOSE DAMAGES CAN BE DISCLAIMED BY LAW. (if applicable)

NON - COVERAGE OF THE GUARANTEE

The consumable items within the product are not covered by the warranty, nor is the glass
If the end-user's claim should not be covered by this guarantee, the end-user shall be liable for costs incurred by Broseley Fires such as callout and inspection costs for examination of the product, transportation costs of the product as well as any other relevant costs.
If, after having been informed about the non-coverage of the guarantee, the end-user wants to have the repairs done, the end-user shall additionally pay for any spare parts used and for the labour and transportation costs incurred. If repairs are carried out under this guarantee, the remaining guarantee period for the product shall be extended by the period of time that has elapsed since the complaint was officially logged with Broseley Fires until the repairs have been completed

A COPY OF OUR FULL TERMS AND CONDITIONS IS AVAILABLE ON REQUEST.

** End-user means the natural or legal person who owns the product and who has not acquired it with a view to reselling or installing it in the course of business