

Owners Operating Instructions

Minivator 2000 series

Features of your Minivator 2000

Contents

1	Introduction	2
2	British Standards	2
3	Features of your Minivator 2000	3
4	Operating your Minivator 2000	4
	Key Switch	4
	On/Off switch	4
	Operating lever	5
	Hand Control	6
	Folding your stairlift	6
	Operating the Swivel (Not on perch models)	7
	Operating the Powered Swivel	7
	Hinged Track - Powered (Optional)	8
	Trapped articles	9
	Emergency hand winding instructions	9
5	Safety and Servicing	10
	Warnings and Precautions	10
	Servicing	10
6	Battery care and routine care and cleaning	11
	Battery Care and Charging	11
	Routine Care and Cleaning	11
7	Appendix 1 - Wiring diagram	12
	Appendix 2 - Certificate of conformity	13

Introduction

Thank you for selecting a Minivator stairlift. Please read these operating instructions carefully. Your Minivator stairlift has been designed and built with careful attention to detail. In order to obtain many years of trouble free use please follow the instructions, paying particular attention to the care and maintenance requirements. Minivator recommend that you do not undertake maintenance tasks other than routine care and cleaning explained in this handbook.

Please contact your Minivator dealer or our Customer Service Department on 01384 408700 if your stairlift requires attention and we will be pleased to help you.

British Standards

Minivator have been accredited as conforming to the international standard of manufacturing, recognised by the award of ISO 9001.

All Minivator stairlifts are built and tested to conform to the British Standard for stairlifts (BS5776) : 1996 as well as ISO 9386-2 and also carry the CE mark.

Minivator are audited regularly to ensure we continue to conform to ISO 9001 and this provides you with the assurance of using a high quality and well manufactured product.



Features of your Minivator 2000

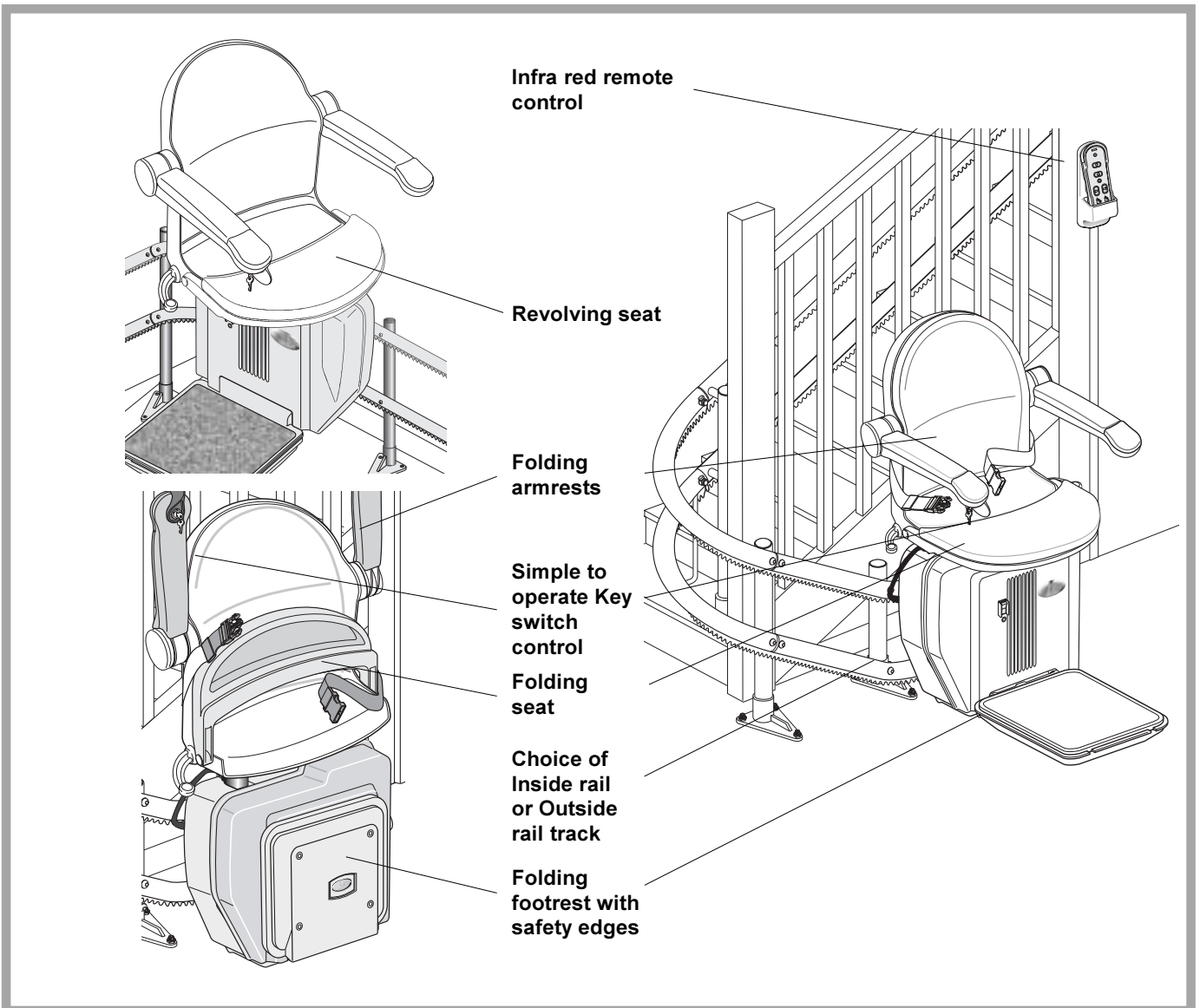

Important information about your stairlift which should be completed by the installation engineer.

Installed by: (Company Name)

Serial No (Company Name)

Date of Installation

First service due

Dealer Stamp



Operating your Minivator 2000

Key Switch

Your Minivator stairlift is fitted with a key switch (Fig. 2).

The stairlift cannot be operated unless the key is inserted and turned to the operating position.

- ⚠ The keyswitch is provided to enable you to lock the stairlift to prevent it being used by others (for example children).

However it can be left in the operating position if desired.

- ⚠ If you remove your key for safety reasons, please ensure you put it in a safe place.

If the keyswitch is turned off while the lift is sitting over the charge contacts the lift will still charge.

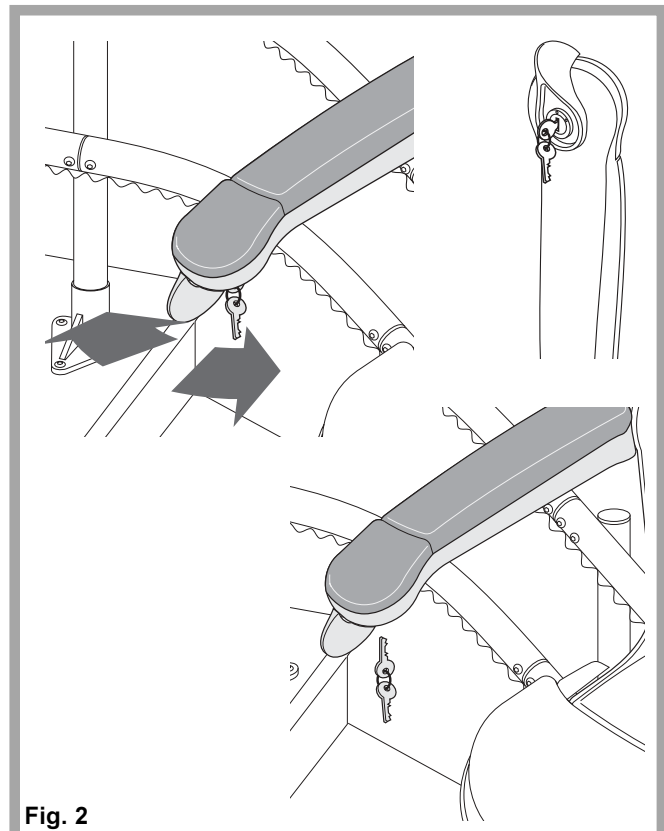

Fig. 2

On/Off switch

As well as a key switch your stairlift is fitted with an On/Off switch (Fig. 3) on the front panel of the lift (below the seat).

- ⚠ Ensure that this is left in the 'ON' position which is indicated by the green light being illuminated.

If you intend to be away from home for a long period, and decide to switch off the mains supply, it is important that you also switch off the lift from this on/off switch.

This will insure that the lift batteries will remain charged while you are away.

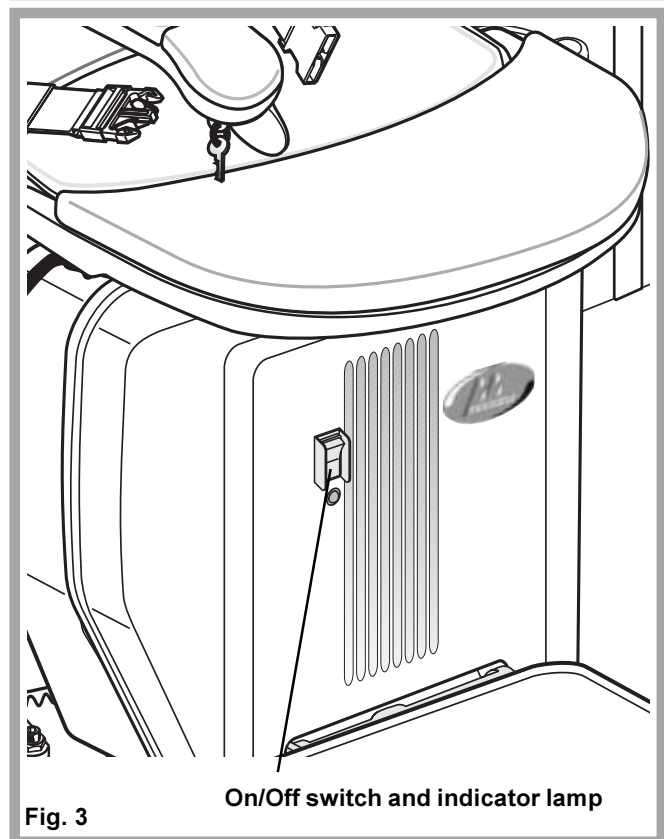
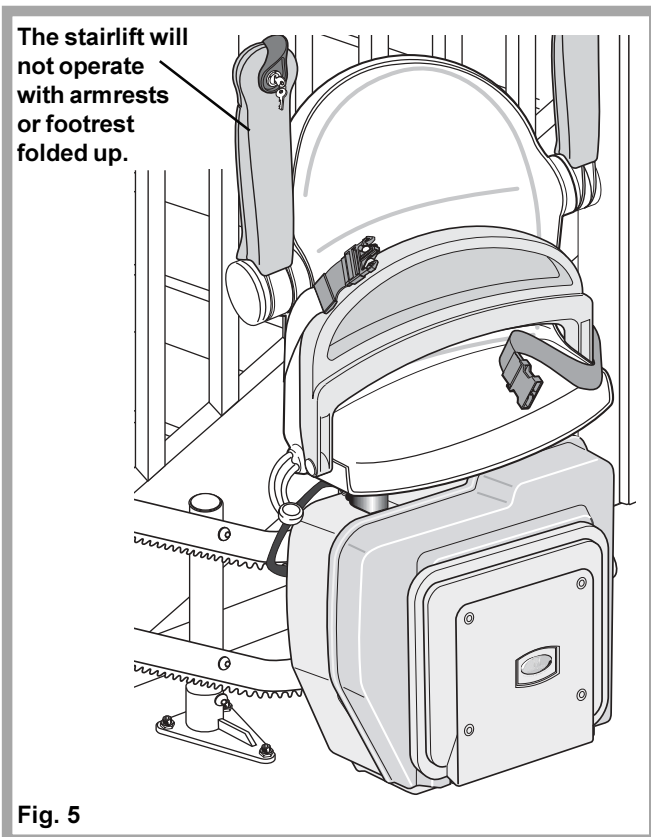
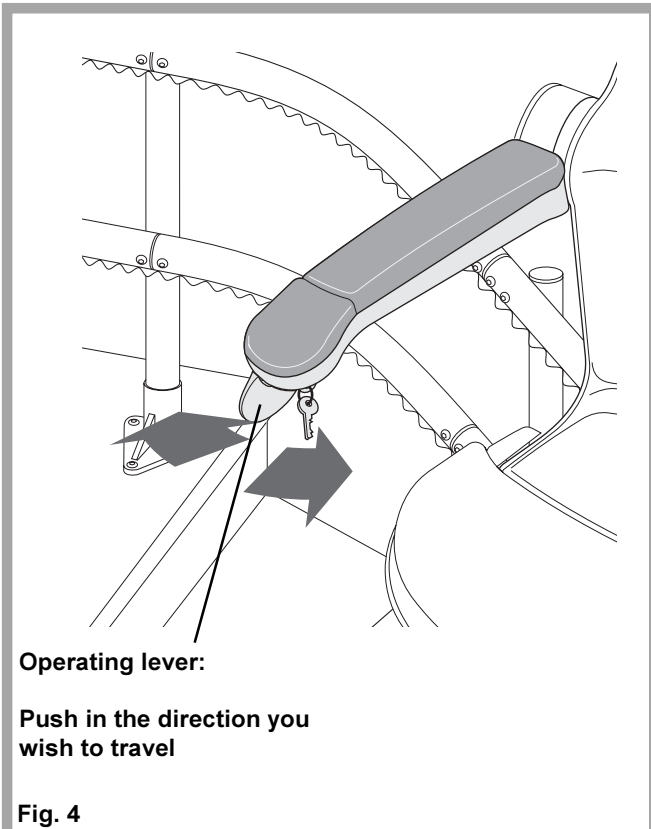

Fig. 3

On/Off switch and indicator lamp





Operating lever

Before using your stairlift, **MOST IMPORTANTLY** please ensure the stairs are clear of other people, pets or any objects which may obstruct your stairlift. Next, ensure arms, footplate and seat are folded down for use, as in the interests of your safety, the stairlift will only operate if they are in their operating position (Fig. 5).

⚠ BEFORE OPERATING YOUR STAIRLIFT ALWAYS FASTEN YOUR LAP BELT.

Your Minivator stairlift is operated by simply pressing and holding the operating lever in the direction you wish to travel (Fig. 4). The stairlift will automatically stop when the switch is released or the stairlift has reached the end of its travel.

⚠ PLEASE NOTE:

In the interest of safety, initial activation of the stairlift is delayed by 1 second from pressing and holding the operating lever, to avoid accidental operation. If the switch is released while the lift is in motion, the lift will stop and a delay of 1 second will occur before the switch will re-start the lift.

When changing the direction of travel the delay will be 3 seconds before the lift begins to move.

Operating your Minivator 2000

Hand Control

The hand control (Fig. 6) is used to call the lift to either the top/bottom of the stairs or to operate a powered folding hinge where fitted. The control may also be used as an attendant control where the user is unable to operate the stairlift themselves.

Please note the hand control can be wall mounted, if required.

- ⚠ Note:- the stairlift must be in its normal operating position (i.e unfolded) before the hand LEVER will work. (See page 5 for details).
- ⚠ The attendant should always remain off the staircase until the stairlift is stationary.

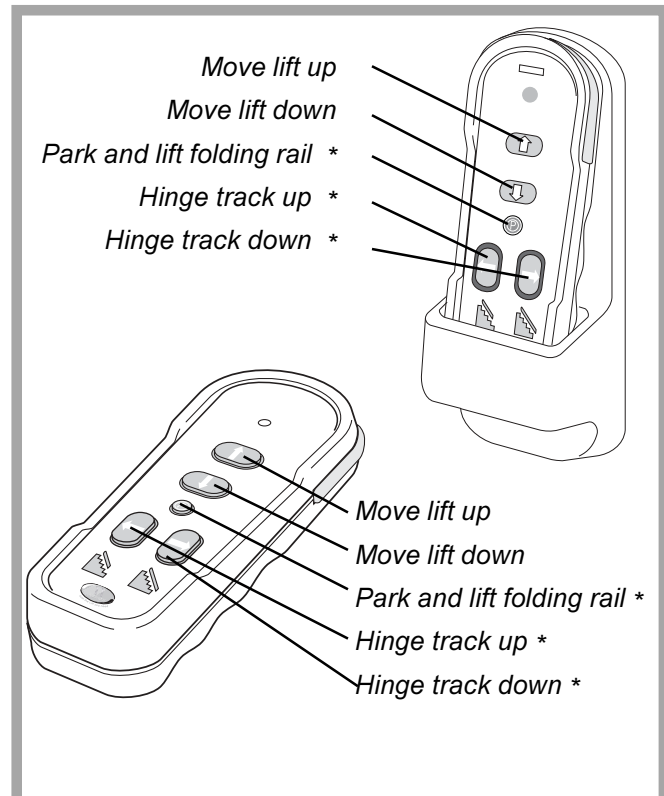

Fig. 6 * Where a powered hinged track is fitted

Folding your stairlift

Your Minivator 2000 seat, armrests and footrest can be folded to allow easier passage up and down stairs when it is not in use (Fig. 7).

- ⚠ Please note: The stairlift will not operate from either the operating lever or the hand control when the footrest or the arm(s) are folded.

⚠ SAFETY PRECAUTION!
ALWAYS RETURN THE STAIRLIFT TO ITS STOWED POSITION. I.E. WITH ARMRESTS, SEAT AND FOOTREST FOLDED AND THE CHAIR PARALLEL TO THE TRACK AS SHOWN IN FIG. 7, SO THAT EXITS ARE NOT OBSTRUCTED.

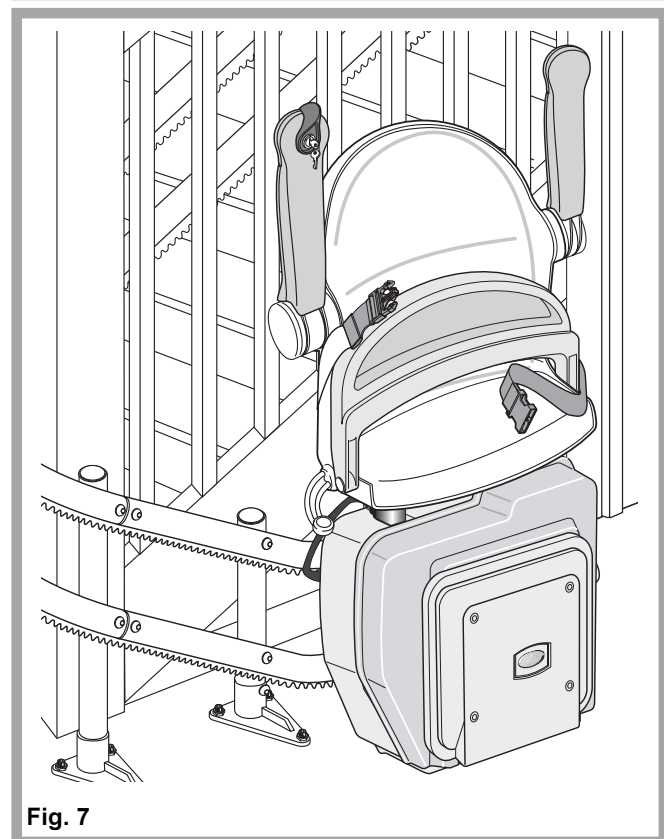

Fig. 7



Operating the Swivel. (Not on perch models)

A swivel seat is provided to enable you to mount/dismount the seat more easily at the top of the stairs by swivelling you on to the landing.

⚠ To operate the seat swivel, wait until the stairlift has stopped.

The lever (Fig. 8) needs to be held up or down whilst you start to swivel. If you release the swivel lever, the seat will lock first at 45°, then at 90°.

You should not attempt to leave the seat until it has firmly 'clicked' into its locked position (Fig. 9).

Operating the Powered Swivel

To operate the powered swivel, when you reach the top (or bottom) of the stairs simply keep the direction lever pressed in the direction you were travelling. The seat will swivel 90° and stop. Release the lever.

⚠ SAFETY PRECAUTIONS

NEVER

Swivel the seat without the lap belt fastened.

NEVER

Mount or dismount the swivel seat unless it is locked in position.

NEVER

Try to operate the swivel seat whilst the stairlift is in motion. (As a safety precaution, should you try to use it whilst the lift is in motion, it will cause the lift to stop).

ALWAYS

Use the swivel seat to travel up or down the staircase in the correct position (i.e. facing directly across the staircase).

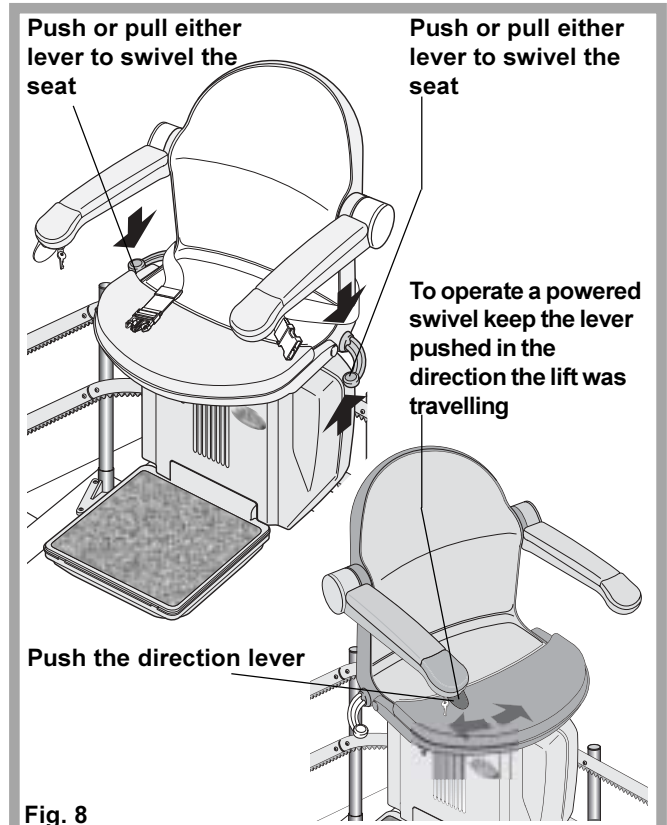

Never use the stairlift with the seat in this position!

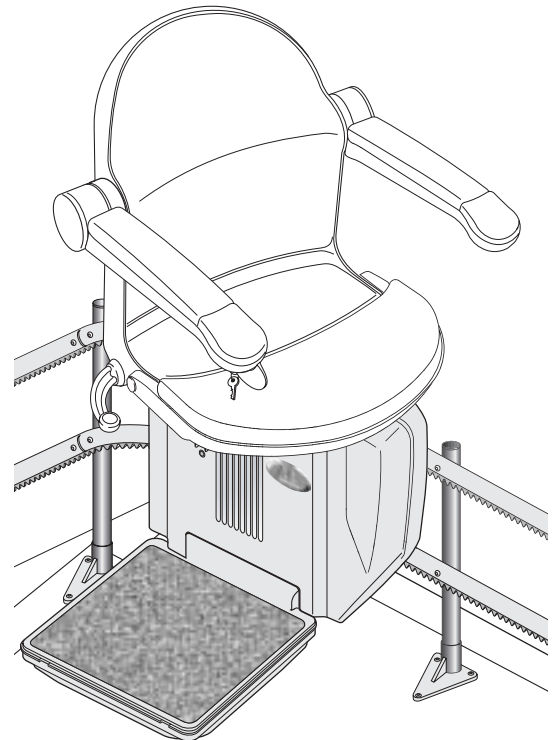

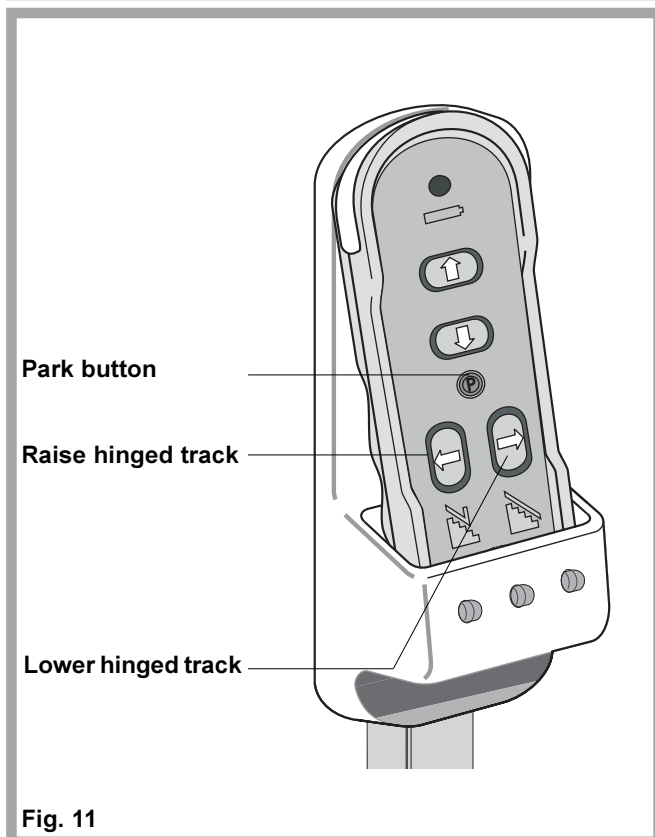
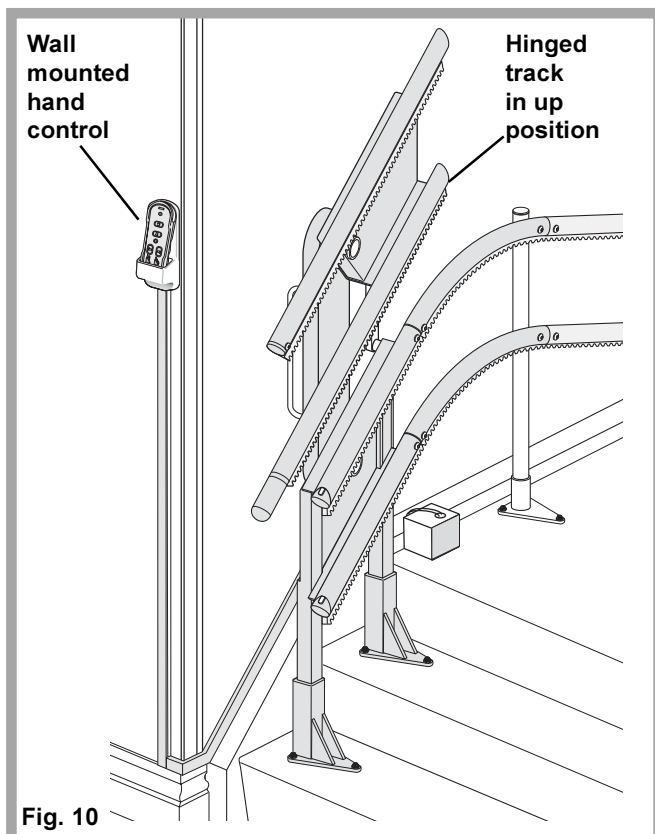

Hinged Track - Powered (Optional)

In some installations a hinged track (Fig. 10), option may be necessary, usually to move the track out of the way of the doorway at the foot of the stairs.

Before raising the hinged track use the hand control (Fig. 10, 11) to park the stairlift on the charge points, above the hinge, or at the top of the stairs.

To raise/lower the hinge track, use the buttons on your hand control (see Fig. 11). The hinged track will raise/lower slowly and stop when it locks into place. Your stairlift will not work unless the track has been lowered.

Your hand control is fitted with a park button (see Fig. 11) which will automatically move the stairlift to the charge points, then raise the track.

⚠ WARNING
BEFORE YOU OPERATE THE HINGE TRACK PLEASE CHECK FOR OBSTACLES

⚠ SAFETY PRECAUTIONS

NEVER

Leave the hinged track down when the stairlift is not in use. If it obstructs a doorway someone may inadvertently walk into it.

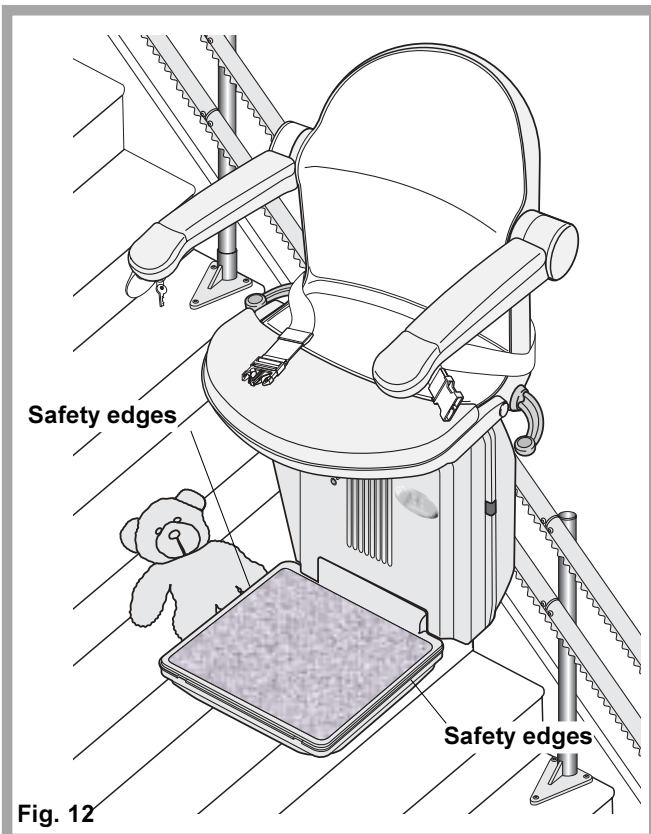

Trapped articles

Your stairlift is fitted with safety edges on the bottom of the footrest and on the lift itself which will stop the stairlift should any article become trapped by the footrest.

- ⚠ To remove the article reverse the stairlift away from the object then have the object removed from the staircase. Proceed on the stairlift as normal.

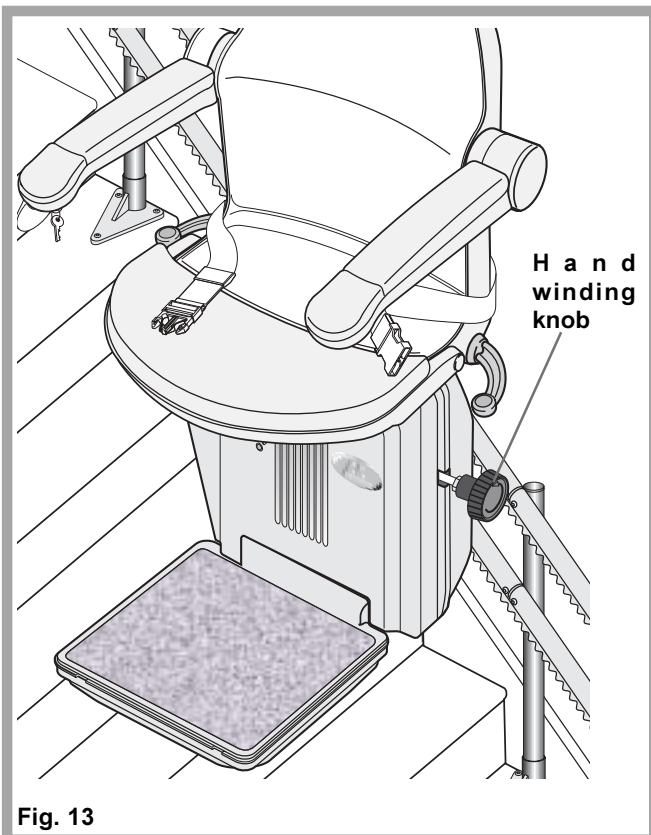

Emergency hand winding instructions

In the unlikely event that the lift has a total power failure or runs on to the final track stops there is an emergency hand winding procedure. Please follow these steps:

1. Switch off the stairlift with the key.
2. Insert the emergency hand winding knob (Fig 13).
3. Turn the knob in the direction indicated for the required movement.
4. When the desired position is reached remove the hand winder and switch the lift on.

If in any doubt contact your local Minivator Approved dealer or ring Minivator direct on 01384 408700

Safety and Servicing

WARNINGS AND PRECAUTIONS

- ⚠ NEVER**
Allow more than one person to use the stairlift at any one time.
The maximum carrying capacity is 137kg (21 stone).
- ⚠ NEVER**
Allow children to play on or with the stairlift.
- ⚠ NEVER**
Allow water to come into contact with the components in the stairlift. If you have to transport liquids **DO SO WITH CARE.**
- ⚠ NEVER**
Place objects in the track, or leave objects on the stairs, where they could come into contact with the lift in operation. Your stairlift is fitted with sensitive side edges and undertray on the footplate, which will automatically stop the lift if it detects any obstructions.
- ⚠ NEVER**
Use the stairlift without using the lap belt, or any other safety belts or harnesses fitted.
- ⚠ NEVER**
Use the stairlift in a standing position unless it has been specifically designed for this i.e. perch model.
- ⚠ ALWAYS**
Keep your **FEET ON THE FOOTPLATE** whilst the stairlift is in motion, and try to avoid your feet hanging over the edges of the footplate.
- ⚠ NEVER**
Swivel the seat until the lift has come to a stop at the top or bottom of the staircase.
- ⚠ ALWAYS**
Fold the chair when it is not in use, to avoid obstructing exits.

SERVICING

We advise that your stairlift is serviced after the first 6 months and thereafter **AT LEAST EVERY 12 MONTHS.**

This work must be carried out by a competent person, i.e a Minivator approved dealer. If in doubt, please contact the Minivator Service Department on 01384 408700.



Battery care and routine care and cleaning

Battery Care and Charging

Your Minivator stairlift is battery powered and will continue to work for a period of time even if you have a power cut. You should normally be able to travel up and down the stairs at least 10 times without needing to charge the batteries. However, you should always ensure that there is sufficient lighting to allow safe travel, especially at each end of the track where you get on and off the lift.

After each journey the stairlift should automatically park on the charge points at the top or the bottom of the rail. To ensure this happens keep the operating lever engaged until the stairlift stops itself.

If a beeping sound occurs this indicates the stairlift is not on its charge point.

If this happens drive the stairlift away from the end of the track and back again until it stops.

 **Note:** Always leave the stairlift on the charge points when it is not in use.

Routine Care and Cleaning

Before cleaning any part of your Minivator stairlift, please ensure you have removed the key.

The Minivator stairlift is manufactured from a variety of materials, all with easy “wipe clean” surfaces. The seat and body covers can be wiped over with a damp, NOT WET, cloth and a small quantity of washing up liquid.

 **PLEASE DO NOT** use abrasive cleaners, bleach or solvent based cleaners, as these will damage the seat.

To clean the track, first send the stairlift to the top of the stairs. The track can be cleaned with a damp cloth. When most of the track is clean, move the stairlift to the bottom of the stairs and finish cleaning the track making sure that none of the cleaning debris falls on to it.

To maintain your Minivator stairlift in good mechanical order, it is recommended that services are carried out by qualified service engineers.

Appendix 1 - Wiring diagram

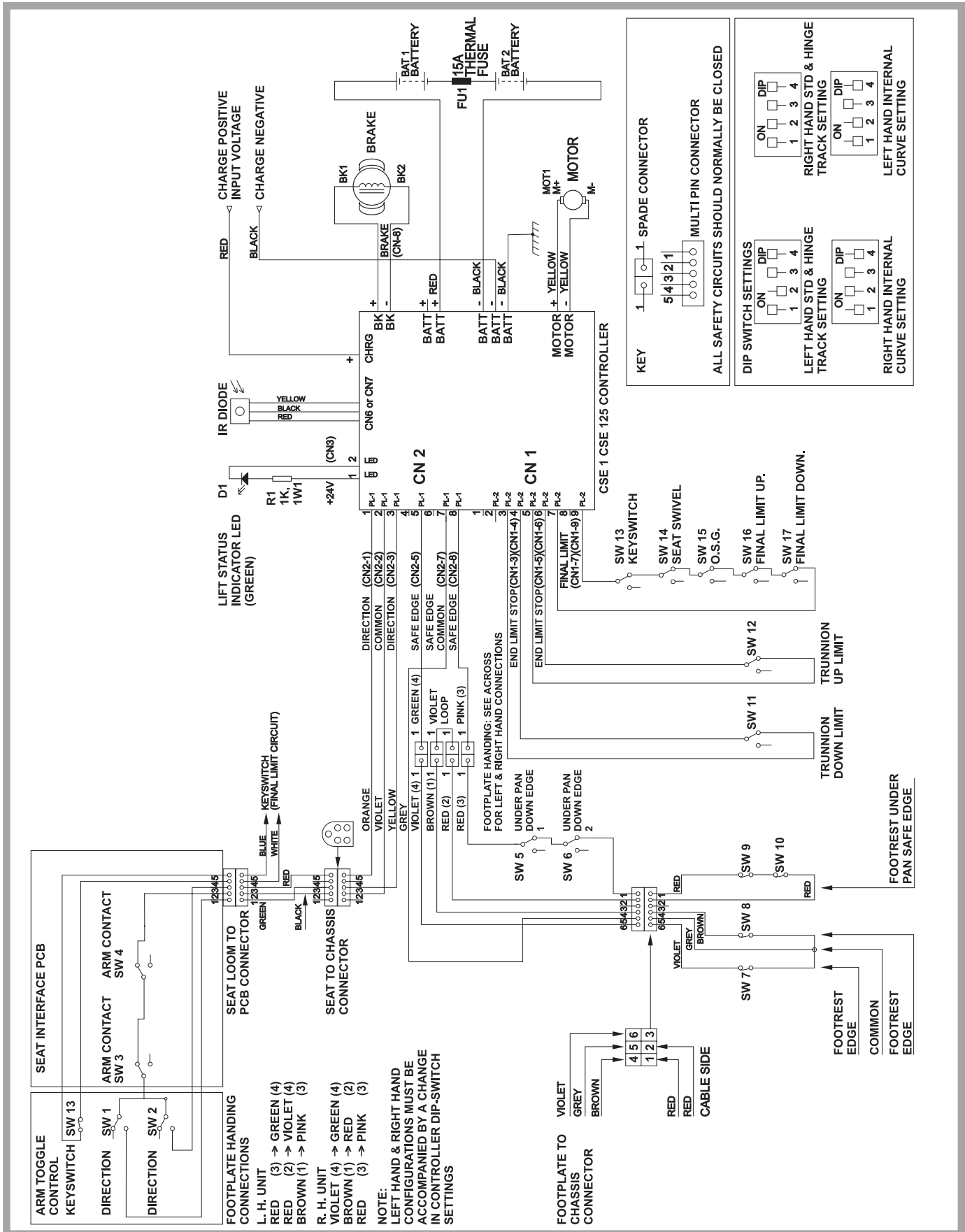

Appendix 2 - Certificate of conformity



Minivator Limited

82 First Avenue
Pensnett Estate
Kingswinford
West Midlands DY6 7FJ
Tel: +44 (0) 1384 408700
Fax: +44 (0) 1384 408719
Email: sales@minivator.co.uk
Website: www.minivator.co.uk

We

Minivator Ltd

Of

82 First Avenue,
Pensnett Estate,
Kingswinford,
West Midlands.
DY6 7FJ.

Declare under our sole responsibility that the product

Minivator 2000 Series Stair Lift

has been manufactured in conformity with the following standards and specification:-

BS5776:1996 Powered Stairlifts

To which this declaration relates is in conformity the following national standards:

Electro Magnetic Compatibility Directive 89/336/EEC

Low Voltage Directive – 73/23/EEC

Machinery Directive – 98/37/EEC

Signed:

Date: December 17, 2003

Name: N.G. Lockett.

Position: Engineering Manager.

Registered in England No. 4109393









*Minivator Ltd. 82, First Avenue, Pensnett Estate, Kingswinford,
West Midlands. DY6 7FJ. England.
Tel. 44(0)1384 408700. Fax. 44(0)1384 408719
'E' mail. sales@minivator.co.uk*
