

OPERATOR'S MANUAL

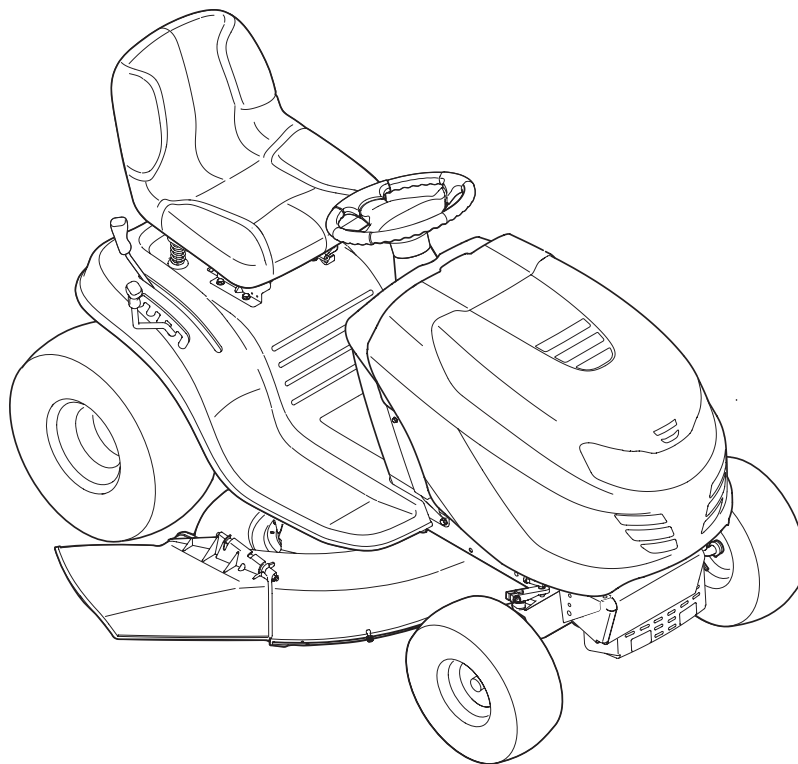

Model Series 79G Hydrostatic Lawn Tractor

⚠ WARNING

**READ AND FOLLOW ALL SAFETY RULES AND INSTRUCTIONS IN THIS MANUAL
BEFORE ATTEMPTING TO OPERATE THIS MACHINE.
FAILURE TO COMPLY WITH THESE INSTRUCTIONS MAY RESULT IN PERSONAL INJURY.**

**LES DISTRIBUTIONS RVI LIMITÉE, 2955, JEAN-BAPTISTE DESCHAMPS, LACHINE, QUEBEC H8T 1C5
MTD LLC, P.O. BOX 361131 CLEVELAND, OHIO 44136-0019**

Thank You

Thank you for purchasing your new equipment. It was carefully engineered to provide excellent performance when properly operated and maintained.

Please read this entire manual prior to operating the equipment. It instructs you how to safely and easily set up, operate and maintain your machine. Please be sure that you, and any other persons who will operate the machine, carefully follow the recommended safety practices at all times. Failure to do so could result in personal injury or property damage.

All information in this manual is relative to the most recent product information available at the time of printing. Review this manual frequently to familiarize yourself with the machine, its features and operation. Please be aware that this Operator's Manual may cover a range of product specifications for various models. Characteristics and features discussed and/or illustrated in this manual may not be applicable to all models.

The manufacturer reserves the right to change product specifications, designs and equipment without notice and without incurring obligation.

If you have any problems or questions concerning the machine, phone your local service dealer or contact us directly. Customer Support telephone numbers, website address and mailing address can be found on this page. We want to ensure your complete satisfaction at all times.

Throughout this manual, all references to *right* and *left* side of the machine are observed from the operating position.

The engine manufacturer is responsible for all engine-related issues with regards to performance, power-rating, specifications, warranty and service. Please refer to the engine manufacturer's Owner's/Operator's Manual, packed separately with your machine, for more information.

Table of Contents

Safe Operation Practices	3	Troubleshooting	29
Assembly & Set-Up	9	Attachments & Accessories	30
Controls & Features.....	12	Replacement Parts	31
Operation.....	15	Emission control warranty statement.....	32
Maintenance & Adjustment.....	19	Warranty.....	34
Service	24		

Record Product Information

Before setting up and operating your new equipment, please locate the model plate on the equipment and record the information in the provided area to the right. You can locate the model plate under the operator's seat. Flip the seat forward to view the model plate. This information will be necessary, should you seek technical support via our web site or with your local dealer.

MODEL NUMBER

--	--	--	--	--	--	--	--	--	--	--	--

SERIAL NUMBER

--	--	--	--	--	--	--	--	--	--	--	--

Customer Support

If you have difficulty assembling this product or have any questions regarding the controls, operation, or maintenance of this machine, call an authorized dealer, see below.

Please have your unit's model number and serial number ready when you call. See previous section to locate this information.

In the U.S.A.:

MTD LLC at P.O. Box 361131, Cleveland, Ohio 44136-0019. Phone: 1-877-282- 8684.

In Canada:

MTD Canada, 97 Kent Avenue, Kitchener, ON N2G 4J1 Phone: 1-800-668-1238 or

LES DISTRIBUTIONS RVI LIMITÉE, 2955, Jean-Baptiste Deschamps, Lachine, Quebec H8T 1C5 Phone: 1-800-361-5770.



WARNING! This symbol points out important safety instructions which, if not followed, could endanger the personal safety and/or property of yourself and others. Read and follow all instructions in this manual before attempting to operate this machine. Failure to comply with these instructions may result in personal injury.

When you see this symbol. **HEED ITS WARNING!**



DANGER! This machine was built to be operated according to the safe operation practices in this manual. As with any type of power equipment, carelessness or error on the part of the operator can result in serious injury. This machine is capable of amputating hands and feet and throwing objects. Failure to observe the following safety instructions could result in serious injury or death.

General Operation

1. Read, understand, and follow all instructions on the machine and in the manual(s) before attempting to assemble and operate. Keep this manual in a safe place for future and regular reference and for ordering replacement parts.
2. Be familiar with all controls and their proper operation. Know how to stop the machine and disengage them quickly.
3. Never allow children under 14 years of age to operate this machine. Children 14 and over should read and understand the instructions and safe operation practices in this manual and on the machine and should be trained and supervised by an adult.
4. Never allow adults to operate this machine without proper instruction.
5. To help avoid blade contact or a thrown object injury, keep bystanders, helpers, children and pets at least 75 feet from the machine while it is in operation. Stop machine if anyone enters the area.
6. Thoroughly inspect the area where the equipment is to be used. Remove all stones, sticks, wire, bones, toys, and other foreign objects which could be picked up and thrown by the blade(s). Thrown objects can cause serious personal injury.
7. Plan your mowing pattern to avoid discharge of material toward roads, sidewalks, bystanders and the like. Also, avoid discharging material against a wall or obstruction which may cause discharged material to ricochet back toward the operator.
8. Always wear safety glasses or safety goggles during operation and while performing an adjustment or repair to protect your eyes. Thrown objects which ricochet can cause serious injury to the eyes.
9. Wear sturdy, rough-soled work shoes and close-fitting slacks and shirts. Loose fitting clothes and jewelry can be caught in movable parts. Never operate this machine in bare feet or sandals.
10. Be aware of the mower and attachment discharge direction and do not point it at anyone. Do not operate the mower without the discharge cover or entire grass catcher in its proper place.
11. Do not put hands or feet near rotating parts or under the cutting deck. Contact with the blade(s) can amputate hands and feet.
12. A missing or damaged discharge cover can cause blade contact or thrown object injuries.
13. Stop the blade(s) when crossing gravel drives, walks, or roads and while not cutting grass.
14. Watch for traffic when operating near or crossing roadways. This machine is not intended for use on any public roadway.
15. Do not operate the machine while under the influence of alcohol or drugs.
16. Mow only in daylight or good artificial light.
17. Never carry passengers.
18. Disengage blade(s) before shifting into reverse. Back up slowly. Always look down and behind before and while backing to avoid a back-over accident.
19. Slow down before turning. Operate the machine smoothly. Avoid erratic operation and excessive speed.
20. Disengage blade(s), set parking brake, stop engine and wait until the blade(s) come to a complete stop before removing grass catcher, emptying grass, unclogging chute, removing any grass or debris, or making any adjustments.
21. Never leave a running machine unattended. Always turn off blade(s), place transmission in neutral, set parking brake, stop engine and remove key before dismounting.

22. Use extra care when loading or unloading the machine into a trailer or truck. This machine should not be driven up or down ramp(s), because the machine could tip over, causing serious personal injury. The machine must be pushed manually on ramp(s) to load or unload properly.
23. Muffler and engine become hot and can cause a burn. Do not touch.
24. Check overhead clearances carefully before driving under low hanging tree branches, wires, door openings etc., where the operator may be struck or pulled from the machine, which could result in serious injury.
25. Disengage all attachment clutches, depress the brake pedal completely and shift into neutral before attempting to start engine.
26. Your machine is designed to cut normal residential grass of a height no more than 10". Do not attempt to mow through unusually tall, dry grass (e.g., pasture) or piles of dry leaves. Dry grass or leaves may contact the engine exhaust and/or build up on the mower deck presenting a potential fire hazard.
27. Use only accessories and attachments approved for this machine by the machine manufacturer. Read, understand and follow all instructions provided with the approved accessory or attachment.
28. Data indicates that operators, age 60 years and above, are involved in a large percentage of riding mower-related injuries. These operators should evaluate their ability to operate the riding mower safely enough to protect themselves and others from serious injury.
29. If situations occur which are not covered in this manual, use care and good judgment. Contact your customer service representative for assistance.

Slope Operation

Slopes are a major factor related to loss of control and tip-over accidents which can result in severe injury or death. All slopes require extra caution. If you cannot back up the slope or if you feel uneasy on it, do not mow it.

For your safety, use the slope gauge included as part of this manual to measure slopes before operating this machine on a sloped or hilly area. If the slope is greater than 15 degrees as shown on the slope gauge, do not operate this machine on that area or serious injury could result.

Do:

1. Mow up and down slopes, not across. Exercise extreme caution when changing direction on slopes.
2. Watch for holes, ruts, bumps, rocks, or other hidden objects. Uneven terrain could overturn the machine. Tall grass can hide obstacles.
3. Use slow speed. Choose a low enough speed setting so that you will not have to stop or shift while on the slope. Tires may lose traction on slopes even though the brakes are functioning properly. Always keep machine in gear when going down slopes to take advantage of engine braking action.
4. Follow the manufacturer's recommendations for wheel weights or counterweights to improve stability.
5. Use extra care with grass catchers or other attachments. These can change the stability of the machine.
6. Keep all movement on the slopes slow and gradual. Do not make sudden changes in speed or direction. Rapid engagement or braking could cause the front of the machine to lift and rapidly flip over backwards which could cause serious injury.

Do Not:

1. Do not turn on slopes unless necessary; then, turn slowly and gradually downhill, if possible.
2. Do not mow near drop-offs, ditches or embankments. The mower could suddenly turn over if a wheel is over the edge of a cliff, ditch, or if an edge caves in.
3. Do not try to stabilize the machine by putting your foot on the ground.
4. Do not use a grass catcher on steep slopes.
5. Do not mow on wet grass. Reduced traction could cause sliding.
6. Do not tow heavy pull behind attachments (e.g. loaded dump cart, lawn roller, etc.) on slopes greater than 5 degrees. When going down hill, the extra weight tends to push the tractor and may cause you to lose control (e.g. tractor may speed up, braking and steering ability are reduced, attachment may jack-knife and cause tractor to overturn).

Children

1. Tragic accidents can occur if the operator is not alert to the presence of children. Children are often attracted to the machine and the mowing activity. They do not understand the dangers. Never assume that children will remain where you last saw them.
 - a. Keep children out of the mowing area and in watchful care of a responsible adult other than the operator.
 - b. Be alert and turn machine off if a child enters the area.
 - c. To avoid back-over accidents, look behind and down for small children.
 - d. Never carry children, even with the blade(s) shut off. They may fall off and be seriously injured or interfere with safe machine operation.
 - e. Use extreme care when approaching blind corners, doorways, shrubs, trees or other objects that may block your vision of a child who may run into the path of the machine.
 - f. Keep children away from hot or running engines. They can suffer burns from a hot muffler.
 - g. Remove key when machine is unattended to prevent unauthorized operation.
2. Never allow children under 14 years of age to operate this machine. Children 14 and over should read and understand the instructions and safe operation practices in this manual and on the machine and should be trained and supervised by an adult.

Towing

1. Tow only with a machine that has a hitch designed for towing. Do not attach towed equipment except at the hitch point.
2. Follow the manufacturers recommendation for weight limits for towed equipment and towing on slopes.
3. Never allow children or others in or on towed equipment.
4. On slopes, the weight of the towed equipment may cause loss of traction and loss of control.
5. Travel slowly and allow extra distance to stop.
6. Do not shift to neutral and coast downhill.

Service

Safe Handling of Gasoline:

1. To avoid personal injury or property damage use extreme care in handling gasoline. **Gasoline is extremely flammable and the vapors are explosive.** Serious personal injury can occur when gasoline is spilled on yourself or your clothes which can ignite. Wash your skin and change clothes immediately.
 - a. Use only an approved gasoline container.
 - b. Never fill containers inside a vehicle or on a truck or trailer bed with a plastic liner. Always place containers on the ground away from your vehicle before filling.
 - c. When practical, remove gas-powered equipment from the truck or trailer and refuel it on the ground. If this is not possible, then refuel such equipment on a trailer with a portable container, rather than from a gasoline dispenser nozzle.
 - d. Keep the nozzle in contact with the rim of the fuel tank or container opening at all times until fueling is complete. Do not use a nozzle lock-open device.
 - e. Extinguish all cigarettes, cigars, pipes and other sources of ignition.
 - f. Never fuel machine indoors.
 - g. Never remove gas cap or add fuel while the engine is hot or running. Allow engine to cool at least two minutes before refueling.
 - h. Never over fill fuel tank. Fill tank to no more than ½ inch below bottom of filler neck to allow space for fuel expansion.
 - i. Replace gasoline cap and tighten securely.
 - j. If gasoline is spilled, wipe it off the engine and equipment. Move machine to another area. Wait 5 minutes before starting the engine.
 - k. To reduce fire hazards, keep machine free of grass, leaves, or other debris build-up. Clean up oil or fuel spillage and remove any fuel soaked debris.
 - l. Never store the machine or fuel container inside where there is an open flame, spark or pilot light as on a water heater, space heater, furnace, clothes dryer or other gas appliances.
 - m. Allow a machine to cool at least five minutes before storing.

General Service

1. Never run an engine indoors or in a poorly ventilated area. Engine exhaust contains carbon monoxide, an odorless, and deadly gas.
2. Before cleaning, repairing, or inspecting, make certain the blade(s) and all moving parts have stopped. Disconnect the spark plug wire and ground against the engine to prevent unintended starting.

3. Periodically check to make sure the blades come to complete stop within approximately (5) five seconds after operating the blade disengagement control. If the blades do not stop within the this time frame, your machine should be serviced professionally by an authorized Service Dealer.
4. Check brake operation frequently as it is subjected to wear during normal operation. Adjust and service as required.
5. Check the blade(s) and engine mounting bolts at frequent intervals for proper tightness. Also, visually inspect blade(s) for damage (e.g., excessive wear, bent, cracked). Replace the blade(s) with the original equipment manufacturer's (O.E.M.) blade(s) only, listed in this manual. "Use of parts which do not meet the original equipment specifications may lead to improper performance and compromise safety!"
6. Mower blades are sharp. Wrap the blade or wear gloves, and use extra caution when servicing them.
7. Keep all nuts, bolts, and screws tight to be sure the equipment is in safe working condition.
8. Never tamper with the safety interlock system or other safety devices. Check their proper operation regularly.
9. After striking a foreign object, stop the engine, disconnect the spark plug wire(s) and ground against the engine. Thoroughly inspect the machine for any damage. Repair the damage before starting and operating.
10. Never attempt to make adjustments or repairs to the machine while the engine is running.
11. Grass catcher components and the discharge cover are subject to wear and damage which could expose moving parts or allow objects to be thrown. For safety protection, frequently check components and replace immediately with original equipment manufacturer's (O.E.M.) parts only, listed in this manual. "Use of parts which do not meet the original equipment specifications may lead to improper performance and compromise safety!"
12. Do not change the engine governor settings or over-speed the engine. The governor controls the maximum safe operating speed of the engine.
13. Maintain or replace safety and instruction labels, as necessary.
14. Observe proper disposal laws and regulations for gas, oil, etc. to protect the environment.
15. According to the Consumer Products Safety Commission (CPSC) and the U.S. Environmental Protection Agency (EPA), this product has an *Average Useful Life* of seven (7) years, or 270 hours of operation. At the end of the *Average Useful Life* have the machine inspected annually by an authorized service dealer to ensure that all mechanical and safety systems are working properly and not worn excessively. Failure to do so can result in accidents, injuries or death.

Do not modify engine

To avoid serious injury or death, do not modify engine in any way. Tampering with the governor setting can lead to a runaway engine and cause it to operate at unsafe speeds. Never tamper with factory setting of engine governor.

Notice Regarding Emissions

Engines which are certified to comply with California and federal EPA emission regulations for SORE (Small Off Road Equipment) are certified to operate on regular unleaded gasoline, and may include the following emission control systems: Engine Modification (EM), Oxidizing Catalyst (OC), Secondary Air Injection (SAI) and Three Way Catalyst (TWC) if so equipped.

Spark Arrestor



WARNING! This machine is equipped with an internal combustion engine and should not be used on or near any unimproved forest-covered, brushcovered or grass-covered land unless the engine's exhaust system is equipped with a spark arrester meeting applicable local or state laws (if any).

If a spark arrester is used, it should be maintained in effective working order by the operator.

A spark arrester for the muffler is available through your nearest engine authorized service dealer.









WARNING! Your Responsibility—Restrict the use of this power machine to persons who read, understand and follow the warnings and instructions in this manual and on the machine.

SAVE THESE INSTRUCTIONS!

Safety Symbols

This page depicts and describes safety symbols that may appear on this product. Read, understand, and follow all instructions on the machine before attempting to assemble and operate.

Symbol	Description
	<p>READ THE OPERATOR'S MANUAL(S) Read, understand, and follow all instructions in the manual(s) before attempting to assemble and operate</p>
	<p>WARNING— ROTATING BLADES Do not put hands or feet near rotating parts or under the cutting deck. Contact with the blade(s) can amputate hands and feet.</p>
	<p>WARNING—THROWN OBJECTS This machine may pick up and throw and objects which can cause serious personal injury.</p>
	<p>WARNING—THROWN OBJECTS This machine may pick up and throw and objects which can cause serious personal injury.</p>
	<p>BYSTANDERS Keep bystanders, helpers, children and pets at least 75 feet from the machine while it is in operation.</p>
	<p>WARNING— SLOPE OPERATION Do not operate this machine on a slope greater than 15 degrees.</p>
	<p>DANGER — ROTATING BLADES To reduce the risk of injury, keep hands and feet away. Do not operate unless discharge cover or grass catcher is in its proper place. If damaged, replace immediately.</p>

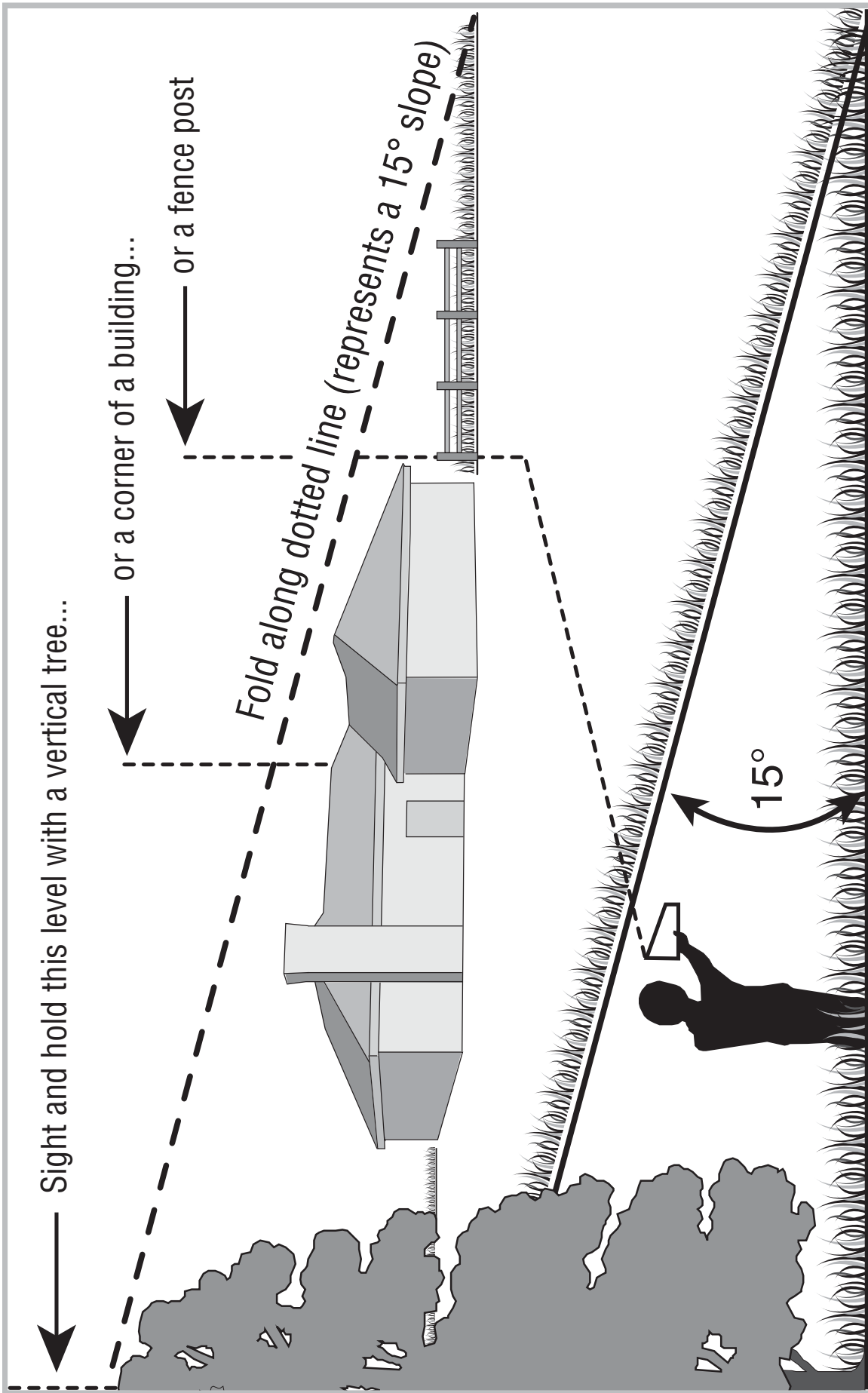

Use this page as a guide to determine slopes where you may not operate safely.



WARNING! Do not operate your lawn mower on such slopes. Do not mow on inclines with a slope in excess of 15 degrees (a rise of approximately 2-1/2 feet every 10 feet). A riding mower could overturn and cause serious injury. Operate riding mowers up and down slopes, never across the face of slopes.

Tractor Set-Up

NOTE: This Operators Manual covers a range of product specifications for various models. Characteristics and features discussed and/or illustrated in this manual may not be applicable to all models. The manufacturer reserves the right to change product specifications, designs and equipment without notice and without incurring obligation.

Connecting the Battery Cables



CALIFORNIA PROPOSITION 65 WARNING:

Battery posts, terminals, and related accessories contain lead and lead compounds, chemicals known to the State of California to cause cancer and reproductive harm. Wash hands after handling.



CAUTION: When attaching battery cables, always connect the POSITIVE (Red) wire to its terminal first, followed by the NEGATIVE (Black) wire.

For shipping reasons, both battery cables on your equipment may have been left disconnected from the terminals at the factory. To connect the battery cables, proceed as follows:

NOTE: The positive battery terminal is marked Pos. (+). The negative battery terminal is marked Neg. (-).

1. Remove the plastic cover, if present, from the positive battery terminal and attach the red cable to the positive battery terminal (+) with the bolt and hex nut. See Fig. 1-1.

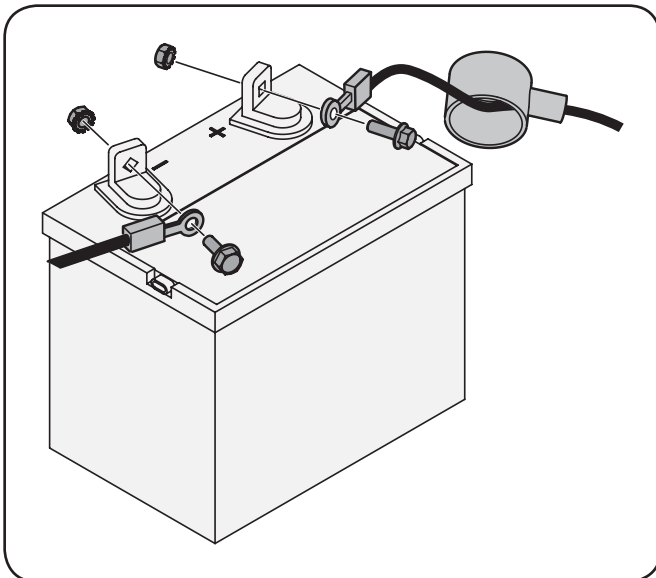

Figure 3-1

2. Remove the plastic cover, if present, from the negative battery terminal and attach the black cable to the negative battery terminal (-) with the bolt and hex nut. See Fig. 1-1.
3. Position the red rubber boot over the positive battery terminal to help protect it from corrosion.

NOTE: If the battery is put into service after the date shown on top/side of battery, charge the battery as instructed in the Maintenance section your Operator's Manual prior to operating the tractor.

Shipping Brace Removal



WARNING! Make sure the riding mower's engine is off, remove the ignition key, and set the parking brake before removing the shipping brace. Refer to the Controls and Features section for instructions on how to set the parking brake.

- Locate the shipping brace, if present, and accompanying warning tag found on the right side of the mower, between the discharge chute and the cutting deck. See Fig. 3-2.

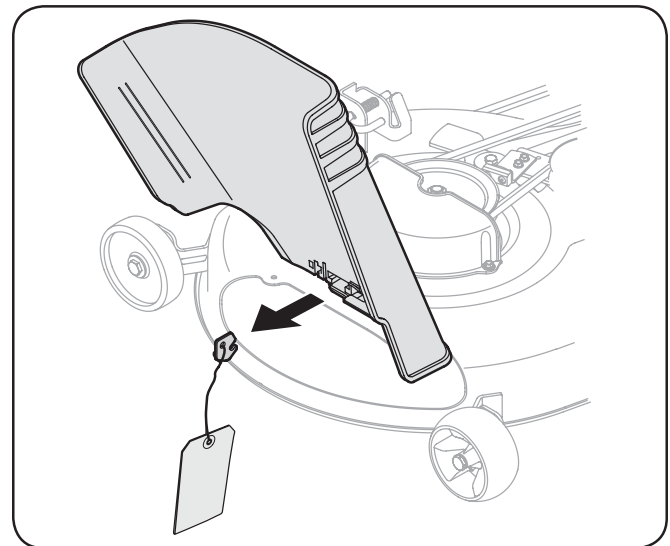

Figure 3-2

- Place the deck lift lever in the highest cutting position. Refer to Setting the Cutting Height in the Operation section of this manual.
- While pushing the discharge chute towards the machine with your left hand, remove the shipping brace with your right hand by grasping it between your thumb and index finger and rotating it clockwise.



WARNING! The shipping brace, used for packaging purposes only, must be removed and discarded before operating your riding mower.



WARNING! The mowing deck is capable of throwing objects. Failure to operate the riding mower with the discharge cover in the proper operating position could result in serious personal injury and/or property damage.

Attaching The Steering Wheel

If the steering wheel for your tractor did not come attached, the hardware for attaching it has been packed within the steering wheel, beneath the steering wheel cap. Carefully pry off the steering wheel cap and remove the hardware.

NOTE: There are two different styles of steering wheel caps. Styles vary by model.

1. With the wheels of the tractor pointing straight forward, place the steering wheel over the steering shaft.

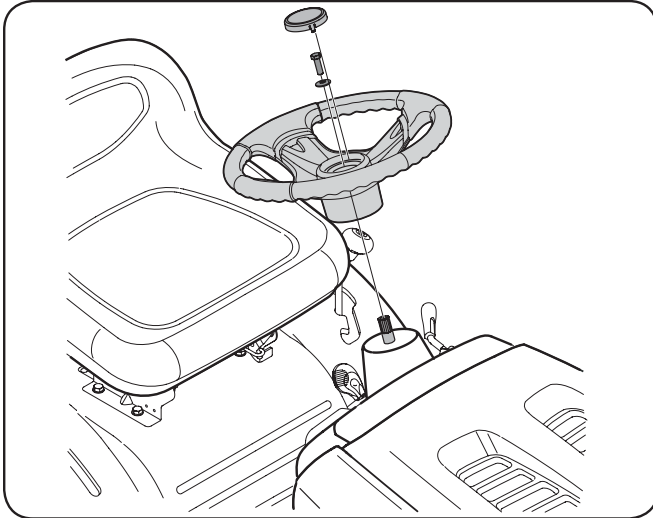

Figure 3-3

2. Place the washer (with the cupped side down) over the steering wheel and secure with the hex bolt. See Fig. 3-3.
3. Place the steering wheel cap over the center of the steering wheel and push downward until it “clicks” into place.

Attaching The Dash Collar

If the tractor’s dash collar did not come attached from the factory, the screws for attaching it can be found in either side of the dash console. Remove the two screws from the console and secure the dash collar as illustrated in Fig 3-4.

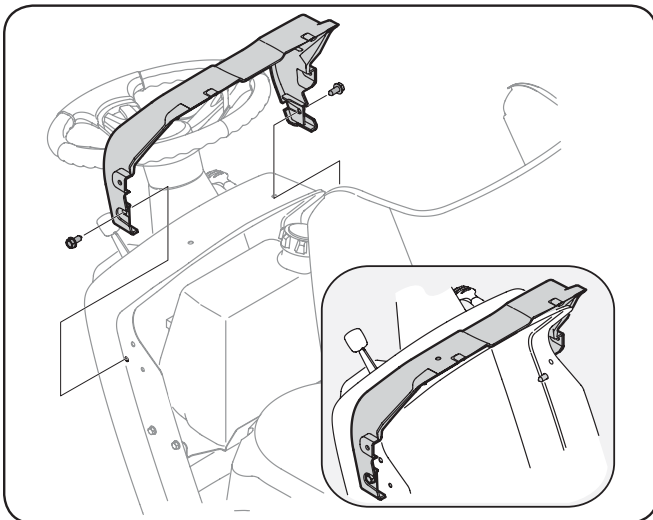

Figure 3-4

Attaching The Seat

If the seat for your tractor was not attached at the factory, follow the applicable instructions below to attach it.

NOTE: For shipping reasons, some seats are not attached at the factory. In this is the case, free the seat from its shipping position and remove the hex screw (or knob screw if applicable) from the bottom of seat before proceeding with the following instructions.

4. Position the seat facing forward over the seat pivot bracket, with the two forward seat mount tabs fitting into the provided grooves in the seat pivot bracket.
5. Slide the seat rearward and align the center mounting hole in the seat with the slot in the seat pan. Insert the hex screw (or knob screw if applicable) previously removed. Do not tighten at this point.
6. Adjust the seat to the optimal operator preferred location, this may mean actually sitting in the seat to decide what feels best to the operator. Keep in mind the operator needs to be able to fully operate all pedals comfortably while sitting back in the seat.
7. Tighten the hex screw (or knob screw if applicable) at this time.
8. To adjust the position of the seat, loosen the hex screw (or knob screw if applicable) on the bottom of the seat. Slide the seat forward or backward as desired. Retighten the hex screw (or knob screw if applicable). See Fig. 3-5.

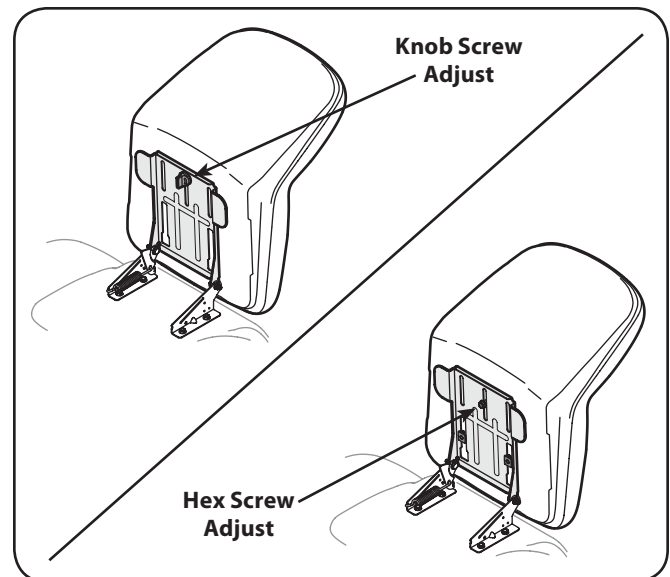

Figure 3-5

Mulch Plug (optional)

Note: See the Attachments & Accessories section if you would like information regarding adding a mulching system for your model of tractor.

Tire Pressure



WARNING! Maximum tire pressure under any circumstances is 30 psi. Equal tire pressure should be maintained at all times. Never exceed the maximum inflation pressure shown on the sidewall of the tire.

The recommended operating tire pressure is:

- Approximately 10 psi for the rear tires
- Approximately 14 psi for the front tires

IMPORTANT: Refer to the tire sidewall for exact tire manufacturer's recommended or maximum psi. Do not overinflate. Uneven tire pressure could cause the cutting deck to mow unevenly.

Gas and Oil Fill-up

The gasoline tank is located under the hood. Do not overfill.



WARNING! Use extreme care when handling gasoline. Gasoline is extremely flammable and the vapors are explosive. Never fuel machine indoors or while the engine is hot or running. Extinguish cigarettes, cigars, pipes, and other sources of ignition.

Service the engine with gasoline and oil as instructed in the separate Engine Operator/Owner Manual packed with your tractor. Read the instructions carefully.

IMPORTANT: Your tractor is shipped with motor oil in the engine. However, **you MUST check the oil level before operating.** Be careful not to overfill.

Setting the Deck Gauge Wheels (if so equipped)

Move the tractor on a firm and level surface, preferably pavement, and proceed as follows

1. Select the height position of the cutting deck by placing the deck lift lever in the normally desired mowing height setting (*any of the six different cutting height notches on the right fender*).
2. Check the gauge wheels for contact or excessive clearance with the surface below. The deck gauge wheels should have between ¼-inch and ½-inch clearance above the ground as follows:

If the gauge wheels have excessive clearance or contact with the surface, adjust as follows:

- a. Raise the deck lift handle to its highest setting.
- b. Remove the gauge wheels by removing the lock nuts and shoulder screws which secure them to the deck. See Fig. 3-6.
- c. Place the deck lift lever in the desired mowing height setting.
- d. Reinsert the shoulder screw (with each gauge wheel) into the index hole that leaves approximately ½-inch between the bottom of the wheel and the pavement.

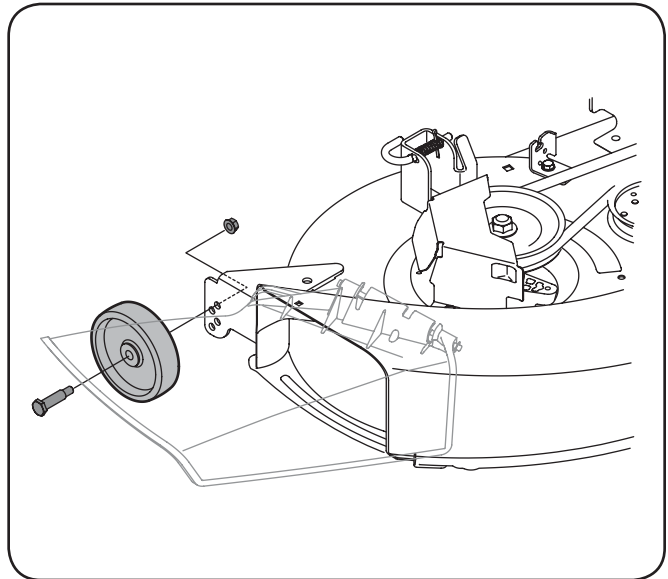

Figure 3-6

Refer to **Leveling the Deck** in the Maintenance section of this manual for more detailed instructions regarding various deck adjustments.

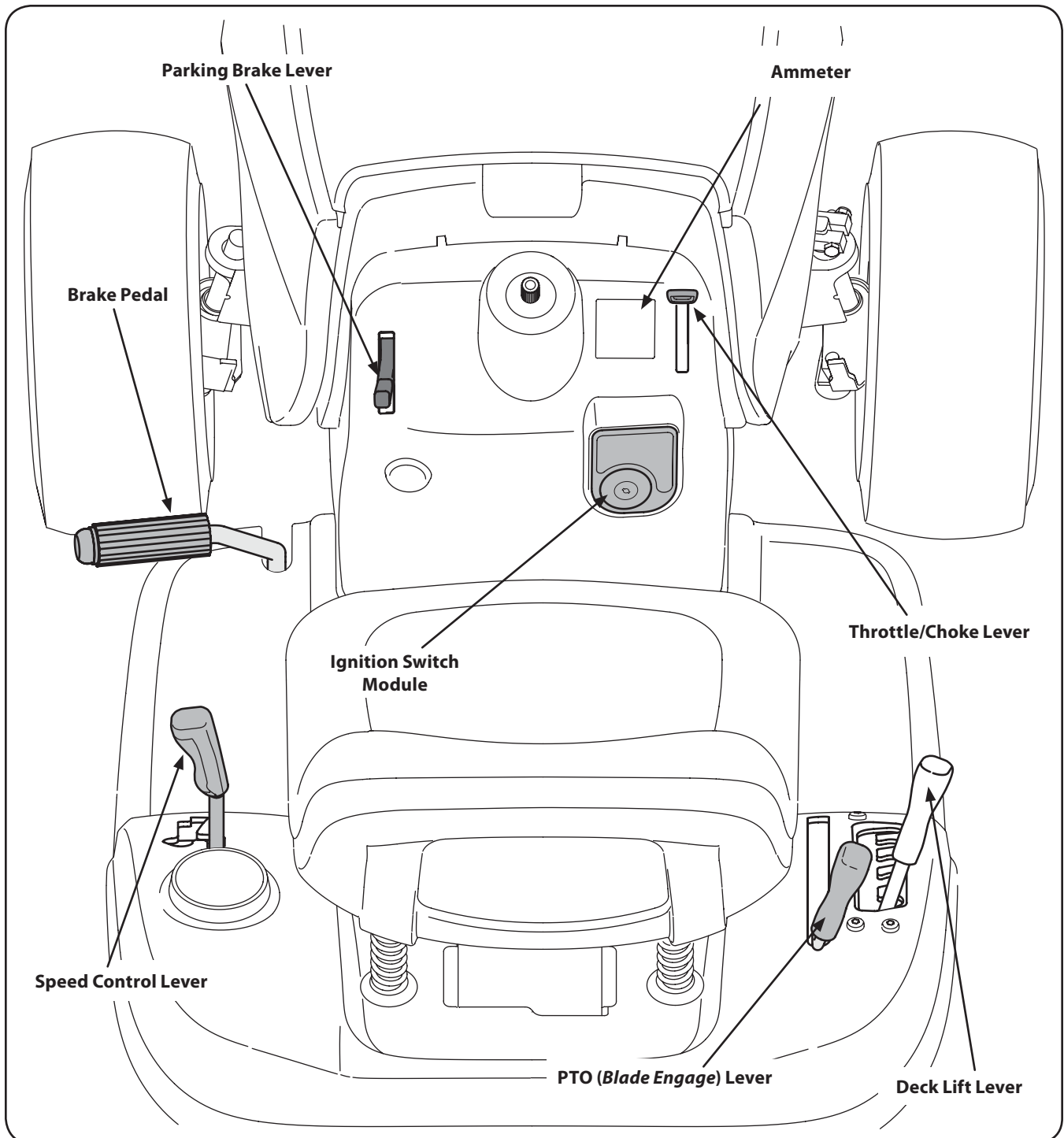

Figure 4-1

Lawn Tractor controls and features are illustrated in Fig 4-1 and described on the following pages.



WARNING! Read and follow all safety rules and instructions in this manual, including the entire Operation section, before attempting to operate this machine. Failure to comply with all safety rules and instructions may result in personal injury.

Throttle Control Lever

The throttle control lever is located on the right side of the tractor's dash panel. This lever controls the speed of the engine and, on some models, when pushed all the way forward, the choke control also. When set in a given position, the throttle will maintain a uniform engine speed. See Fig. 4-2.

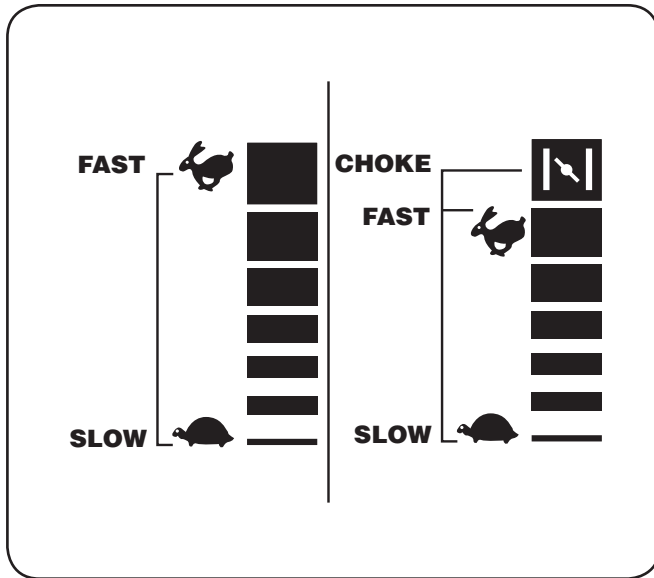
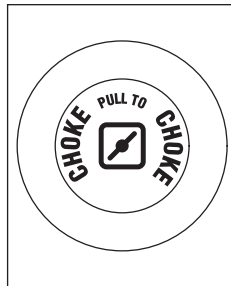

Figure 4-2

IMPORTANT: When operating the tractor with the cutting deck engaged, be certain that the throttle lever is always in the FAST (rabbit) position.

Choke Control

On some models, moving the throttle lever all the way forward activates the engine's choke control. On all other models, the choke control can be found on the left side of the dash panel and is activated by pulling the knob outward. Activating the choke control closes the choke plate on the carburetor and aids in starting the engine. Refer to Starting The Engine on page 15 of this manual for detailed starting instructions.



Ignition Switch

Your new lawn tractor will have one of the following ignition switches. Use Fig. 4-3 to identify which switch your machine utilizes and follow these instructions for proper operation.

3-Position Ignition Switch

The ignition switch is activated to start the engine. Insert key into the ignition switch and turn clockwise to the START position. Release the key into the ON position once engine has fired. See Fig. 4-3A. The engine will run with the headlights on.

To stop the engine, turn the ignition key counterclockwise to the OFF position. See Fig. 4-3A.

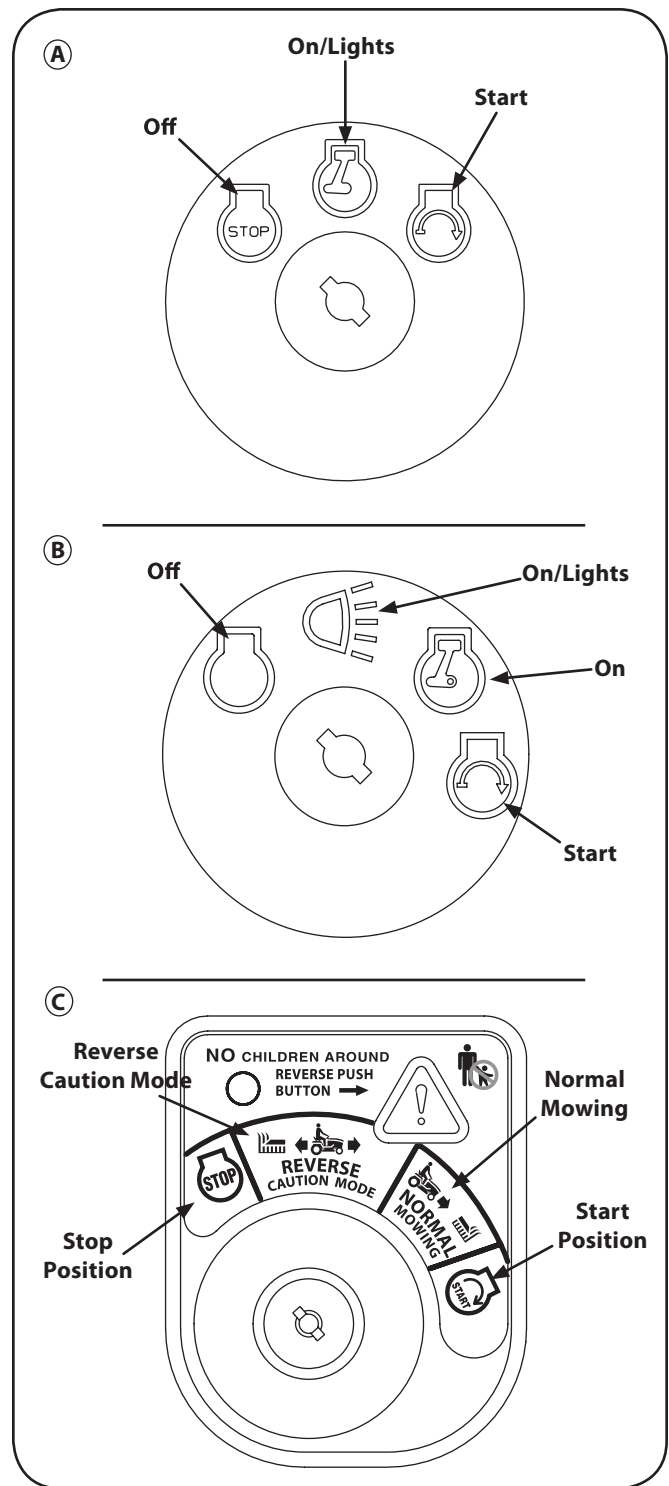

Figure 4-3

4-Position Ignition Switch

The ignition switch is activated to start the engine. Insert key into the ignition switch and turn clockwise to the START position. Release the key into the ON position once engine has fired. See Fig. 4-3B. The engine will run with the headlights off in this position. To activate the headlights, turn the key one more position to the left. The engine will continue to run with the headlights on.

To stop the engine, turn the ignition key counterclockwise to the OFF position. See Fig. 4-3B.

Ignition Switch Module

To start the engine, insert the key into the ignition switch and turn clockwise to the START position. Release the key into the NORMAL MOWING MODE position once the engine has fired. The headlights will be activated in the Normal (and Reverse Caution Modes).

To stop the engine, turn the ignition key counterclockwise to the OFF position. See Fig. 4-3C.



WARNING! Never leave a running machine unattended. Always disengage PTO, move shift lever into neutral position, set parking brake, stop engine and remove key to prevent unintended starting.

IMPORTANT: Prior to operating the tractor, refer to both Safety Interlock Switches and Starting The Engine in the Operation section of this manual for detailed instructions regarding the Ignition Switch Module and operating the tractor in REVERSE CAUTION MODE.

Deck Lift Lever

Found on your tractor's right fender, the deck lift lever is used to change the height of the cutting deck. To use, move the lever to the left, then place in the notch best suited for your application.

Brake Pedal

The brake pedal is located on the left side of the lawn tractor, along the running board. Depress the brake pedal part way down to slow the tractor's ground speed. Depress the pedal all the way down to engage the disc brake and bring the tractor to a complete stop.

NOTE: The pedal must be depressed to start the engine. Refer to Safety Interlock Switches on page 15.

Parking Brake

To set the parking brake, fully depress the brake pedal. Move the parking brake lever into the ON position. Release the brake pedal to allow the parking brake to engage.

To release the parking brake, depress the brake pedal and move the parking brake lever out of the ON position and into the OFF position.

NOTE: The parking brake must be set if the operator leaves the seat with the engine running or the engine will automatically shut off.

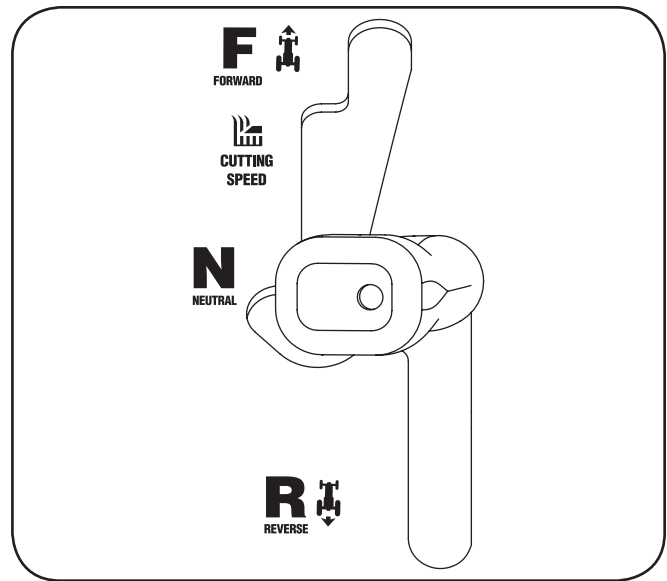

Figure 4-4

Speed Control Lever

The speed control lever, located on the left fender, allows you to regulate the travel direction and ground speed of the lawn tractor. To use, release the parking brake and move the speed control lever forward (to travel forward) or rearward (to travel in reverse). The further forward or rearward that the lever is moved, the faster the tractor will travel. See Fig. 4-4.

Place the speed control lever in the Cutting Speed, or slower, position when mowing.

IMPORTANT: Do NOT attempt to change the direction of travel when the tractor is in motion. Serious damage to the tractor's transmission could result. Always bring the tractor to a complete stop before moving the speed control lever from forward to reverse or vice versa.

IMPORTANT: Always set the parking brake when leaving the tractor unattended.

PTO (Blade Engage) Lever

Found on the tractor's right fender, the PTO (*blade engage*) lever is used to engage power to the cutting deck or other (*separately available*) attachments. To operate, move the lever all the way forward. Moving the lever all the way rearward into the PTO OFF position disengages power to the cutting deck/ attachment.

NOTE: The PTO (*blade engage*) lever must be in the disengaged (PTO OFF) position when starting the engine.

WARNING

TO AVOID SERIOUS INJURY OR DEATH

- **GO UP AND DOWN SLOPES, NOT ACROSS.**
- **AVOID SUDDEN TURNS.**
- **DO NOT OPERATE THE UNIT WHERE IT COULD SLIP OR TIP.**
- **IF MACHINE STOPS GOING UPHILL, STOP BLADE(S) AND BACK DOWNHILL SLOWLY.**
- **KEEP SAFETY DEVICES (GUARDS, SHIELDS, AND SWITCHES, ETC.) IN PLACE AND WORKING.**
- **REMOVE OBJECTS THAT COULD BE THROWN BY THE BLADE(S).**
- **KNOW LOCATION AND FUNCTION OF ALL CONTROLS.**
- **BE SURE BLADE(S) AND ENGINE ARE STOPPED BEFORE PLACING HANDS OR FEET NEAR BLADE(S).**
- **BEFORE LEAVING OPERATOR'S POSITION, DISENGAGE BLADE(S), ENGAGE PARKING BRAKE, SHUT OFF AND REMOVE KEY.**

READ OPERATOR'S MANUAL

Safety Interlock Switches

This tractor is equipped with a safety interlock system for the protection of the operator. If the interlock system should ever malfunction, do not operate the tractor. Contact an authorized MTD service dealer.

- The safety interlock system prevents the engine from cranking or starting unless the parking brake is engaged, and the PTO (*blade engage*) lever is in the disengaged (OFF) position.
- The engine will automatically shut off if the operator leaves the seat before engaging the parking brake.
- The engine will automatically shut off if the operator leaves the tractor's seat with the PTO (*blade engage*) lever in the engaged (ON) position, regardless of whether the parking brake is engaged.

Models without Reverse Caution Mode

- The engine will automatically shut off if the PTO (*blade engage*) lever is moved into the engaged (ON) position with the speed control lever in Reverse.

Models with Reverse Caution Mode

- With the ignition key in the NORMAL MOWING position, the engine will automatically shut off if the PTO (*blade engage*) lever is moved into the engaged (ON) position with the speed control in Reverse.



WARNING! Do not operate the tractor if the interlock system is malfunctioning. This system was designed for your safety and protection.

Reverse Caution Mode

(Models equipped with ignition switch module)



WARNING! Use extreme caution while operating the tractor in the REVERSE CAUTION MODE. Always look down and behind before and while backing. Do not operate the tractor when children or others are around. Stop the tractor immediately if someone enters the area.

The **REVERSE CAUTION MODE** position of the key switch module allows the tractor to be operated in reverse with the blades (PTO) engaged.

IMPORTANT: Mowing in reverse is not recommended.

To use the REVERSE CAUTION MODE:

IMPORTANT: The operator **MUST** be seated in the tractor seat.

1. Start the engine as instructed on page 16 under Starting The Engine.
2. Turn the key from the NORMAL MOWING (Green) position to the REVERSE CAUTION MODE (Yellow) position of the key switch module. See Fig. 5-1.
3. Depress the REVERSE PUSH BUTTON (Orange, Triangular Button) at the top, right corner of the key switch module. The red indicator light at the top, left corner of the key switch module will be ON while activated. See Fig. 5-1.

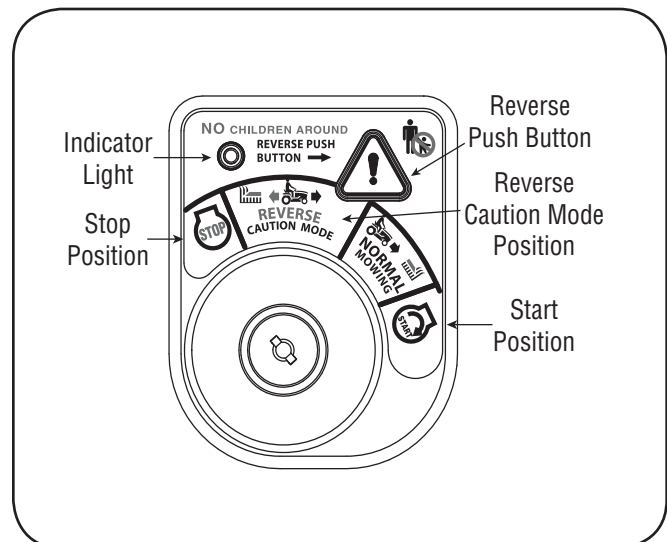

Figure 5-1

- Once activated (indicator light ON), the tractor can be driven in reverse with the cutting blades (PTO) engaged.
- Always look down and behind before and while backing to make sure no children are around.
- After resuming forward motion, return the key to the NORMAL MOWING position.

IMPORTANT: The REVERSE CAUTION MODE will remain activated until:

- The key is placed in either the NORMAL MOWING position or STOP position.
- The operator engages the parking brake by fully depressing the brake pedal and holding it down while moving the parking brake lever into the PARK BRAKE position.

Engaging the Parking Brake.

To engage the parking brake:

- Fully depress the brake pedal and hold it down with your foot.
- Move the parking brake lever all the way down and into the ON position.
- Release the brake pedal to allow the parking brake to engage.

To release the parking brake:

- Depress the brake pedal and move the parking brake lever out of the ON position and into the OFF position.

Setting the Cutting Height

- Select the height position of the cutting deck by placing the deck lift lever in any of the six different cutting height notches on the right side of the fender.
- Adjust the deck wheels, if equipped, so that they are between ¼-inch and ½-inch above the ground when the tractor is on a smooth, flat surface such as a driveway.



WARNING! Keep hands and feet away from the discharge opening of the cutting deck.

NOTE: On models so equipped, the deck wheels are an anti-scalp feature of the deck and are not designed to support the weight of the cutting deck.

Refer to Leveling the Deck on page 20 of this manual for more detailed instructions regarding various deck adjustments.

Starting the Engine



WARNING! Do not operate the tractor if the interlock system is malfunctioning. This system was designed for your safety and protection.

NOTE: Refer to the TRACTOR SET-UP of this manual for Gasoline and Oil fill-up instructions.

- Insert the tractor key into the ignition switch.
- Place the PTO (*blade engage*) lever in the disengaged (OFF) position.

- Engage the tractor's parking brake.
- Activate the choke control.
- Turn the ignition key clockwise to the START position. After the engine starts, release the key. It will return to the ON (or Normal Mowing) position.

IMPORTANT: Do NOT hold the key in the START position for longer than ten seconds at a time. Doing so may cause damage to your engine's electric starter.

- After the engine starts, deactivate the choke control and place the throttle control in the FAST position.

NOTE: Do NOT leave the choke control on while operating the tractor. Doing so will result in a "rich" fuel mixture and cause the engine to run poorly.

Stopping the Engine



WARNING! If you strike a foreign object, stop the engine, disconnect the spark plug wire(s) and ground against the engine. Thoroughly inspect the machine for any damage. Repair the damage before restarting and operating

- If the blades are engaged, place the PTO (*blade engage*) lever in the disengaged (OFF) position.
- Turn the ignition key counterclockwise to the STOP position.
- Remove the key from the ignition switch to prevent unintended starting.

Driving The Tractor



WARNING! Always look down and behind before and while traveling in reverse to avoid a back-over accident.

WARNING! Before leaving the operator's position. Always place the PTO (*blade engage*) lever in the disengaged (PTO OFF) position, place speed control lever in neutral, set parking brake, stop engine and remove key to prevent unintended starting. Depress the brake pedal to release the parking brake and let the pedal up.

- Move the throttle lever into the FAST (rabbit) position.

NOTE: Always operate the tractor with the throttle control lever in the FAST (rabbit) position for the most efficient use of the cutting deck or other (separately available) attachments.

- Release the parking brake by depressing the brake pedal
- Position the speed control lever in desired position. The further forward or rearward that the lever is moved, the faster the tractor will travel.



WARNING! Do NOT attempt to change the direction of travel when the tractor is in motion. Always bring the tractor to a complete stop before moving the speed control lever from forward to reverse or vice versa. Failure to do so could result in serious damage to your tractor's transmission.

IMPORTANT: First-time operators should use slower speeds. Become completely familiar with the tractor's operation and controls before operating the tractor in at higher speed.

- The lawn tractor is brought to a stop by depressing the brake pedal.
- Set the parking brake by fully depressing the brake pedal and keeping it depressed while placing the parking brake lever in the ON position. Release the brake pedal to allow the parking brake to engage.



WARNING! Before leaving the operator's position for any reason, disengage the blades, place the speed control lever in neutral, engage the parking brake, shut engine off and remove the key.

IMPORTANT: When stopping the tractor for any reason while on a grass surface, always:

- Place the speed control lever in N (neutral),
- Engage the parking brake,
- Shut engine off and remove the key.

Doing so will minimize the possibility of having your lawn "browned" by hot exhaust from your tractor's running engine.

Driving On Slopes

Refer to the SLOPE GAUGE on page 7 to help determine slopes where you may operate the tractor safely.



WARNING! Do not mow on inclines with a slope in excess of 15 degrees (a rise of approximately 2-1/2 feet every 10 feet). The tractor could overturn and cause serious injury.

- Mow up and down slopes, NEVER across.
- Exercise extreme caution when changing direction on slopes.
- Watch for holes, ruts, bumps, rocks, or other hidden objects. Uneven terrain could overturn the machine. Tall grass can hide obstacles.
- Avoid turns when driving on a slope. If a turn must be made, turn down the slope. Turning up a slope greatly increases the chance of a roll over.
- Avoid stopping when driving up a slope. If it is necessary to stop while driving up a slope, start up smoothly and carefully to reduce the possibility of flipping the tractor over backward.

Engaging the Blades

Engaging the PTO (*blade engage*) transfers power to the cutting deck. To engage the blades, proceed as follows:

- Move the throttle control lever to the FAST (rabbit) position.
- Grasp the PTO (*blade engage*) lever and pivot it all the way forward into the engaged (ON) position.
- Keep the throttle lever in the FAST (rabbit) position for the most efficient use of the cutting deck or other (separately available) attachments.

IMPORTANT: Models with Reverse Caution Mode:

The engine will automatically shut off if the PTO is engaged with the speed control lever in position for reverse travel with the ignition key in the NORMAL MOWING position.

Models without Reverse Caution Mode:

The PTO (*blade engage*) lever must be in the disengaged (OFF) position when starting the engine, when traveling in reverse, and if the operator leaves the seat. Refer to Safety Interlock Switches on page 15.

Using the Deck Lift Lever

To raise the cutting deck, move the deck lift lever to the left, then place it in the notch best suited for your application. Refer to Setting The Cutting Height earlier in this section.

Mowing



WARNING! To help avoid blade contact or a thrown object injury, keep bystanders, helpers, children and pets at least 75 feet from the machine while it is in operation. Stop machine if anyone enters the area.

The following information will be helpful when using the cutting deck with your tractor:



WARNING! Plan your mowing pattern to avoid discharge of materials toward roads, sidewalks, bystanders and the like. Also, avoid discharging material against a wall or obstruction which may cause discharged material to ricochet back toward the operator.

- Do not mow at high ground speed, especially if a mulch kit or grass collector is installed.
- For best results it is recommended that the first two laps be cut with the discharge thrown towards the center. After the first two laps, reverse the direction to throw the discharge to the outside for the balance of cutting. This will give a better appearance to the lawn.
- Do not cut the grass too short. Short grass invites weed growth and yellows quickly in dry weather.
- Mowing should always be done with the engine at full throttle.
- Under heavier conditions it may be necessary to go back over the cut area a second time to get a clean cut.
- Do NOT attempt to mow heavy brush and weeds and extremely tall grass. Your tractor is designed to mow lawns, NOT clear brush.
- Keep the blades sharp and replace the blades when worn. Refer to Cutting Blades on page 25 of this manual for proper blade sharpening instructions.

Moving The Tractor Manually

Your tractor's transmission is equipped with a hydrostatic relief valve for occasions when it is necessary to move the tractor manually. Activating this valve forces the fluid in the transmission to bypass its normal route, allowing the rear tires to "freewheel." To engage the hydrostatic relief valve, proceed as follows:

1. Locate the hydrostatic bypass rod in the rear of the tractor. See Fig. 5-2.
2. Pull the hydrostatic bypass rod outward, then down and to the left, to lock it in place.

NOTE: The transmission will NOT engage when the hydrostatic bypass rod is pulled out. Return the rod to its normal position prior to operating the tractor.

IMPORTANT: Never attempt to move the tractor manually without first engaging the hydrostatic relief valve. Doing so will result in serious damage to the tractor's transmission.

Headlights

- On some models, the lamps are ON whenever the tractor's engine is running. On other models, the lamps are ON whenever the ignition key is moved out of the STOP position.
- On all models, the lamps turn OFF when the ignition key is moved to the STOP position.

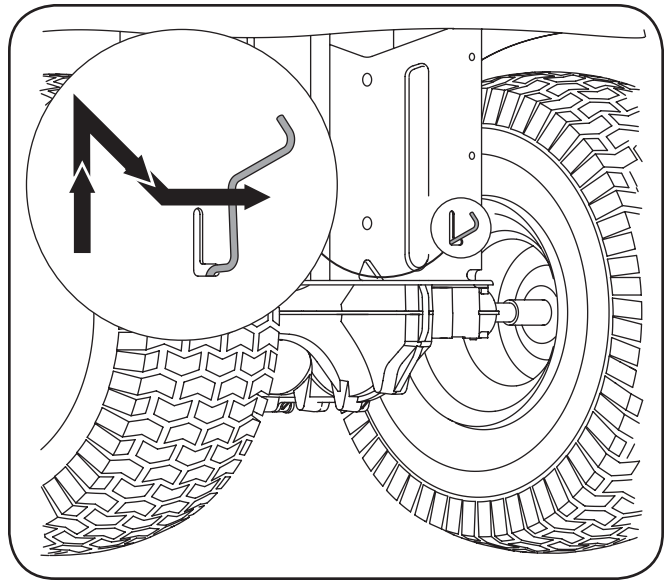

Figure 5-2

Maintenance



WARNING! Before performing any maintenance or repairs, disengage PTO, move shift lever into neutral position, set parking brake, stop engine and remove key to prevent unintended starting.

Engine

Refer to the Engine Operator/Owner Manual for engine maintenance instructions.

Check engine oil level before each use as instructed in the Engine Operator/Owner Manual packed with your unit. Follow the instructions carefully.

Changing Engine Oil and Filter (Models with Briggs & Stratton Engines)

For draining oil from the engine's crankcase of select model tractors, a plastic oil drain sleeve or hose is packed with this Operator's Manual. See Figure 6-1.

1. Change the oil as instructed in the separate Engine Operator/Owner Manual packed with your unit.
2. Service the oil filter (if so equipped) as instructed in the separate Engine Operator/Owner Manual packed with your unit.
3. Refill the engine with the proper quantity and weight of new motor oil as instructed in the Engine Operator/Owner Manual packed with your unit.

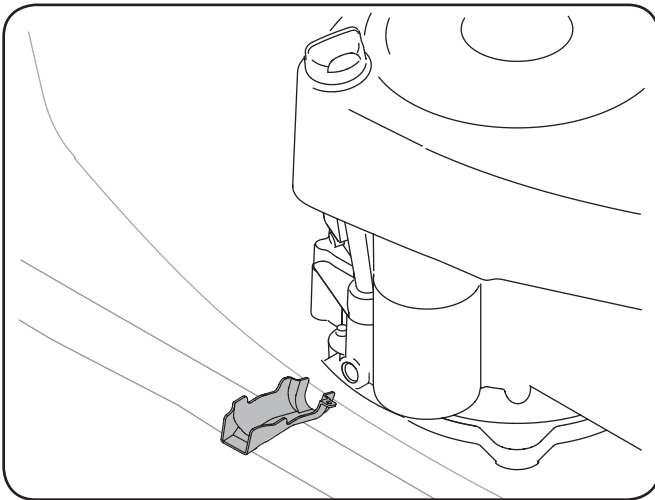

Figure 6-1

Changing the Engine Oil (Models with Kohler Engines)



WARNING! If the engine has been recently run, the engine, muffler and surrounding metal surfaces will be hot and can cause burns to the skin. Exercise caution to avoid burns.

NOTE: The oil filter should be changed at every oil change interval. To complete an oil change, proceed as follows:

1. Run the engine for a few minutes to allow the oil in the crankcase to warm up. Warm oil will flow more freely and carry away more of the engine sediment which may have settled at the bottom of the crankcase. Use care to avoid burns from hot oil.
2. Open the tractor's hood and locate the oil drain port on the right side of the engine.
3. Pop open the protective cap on the end of the oil drain valve to expose the drain port. See Fig 6-2.

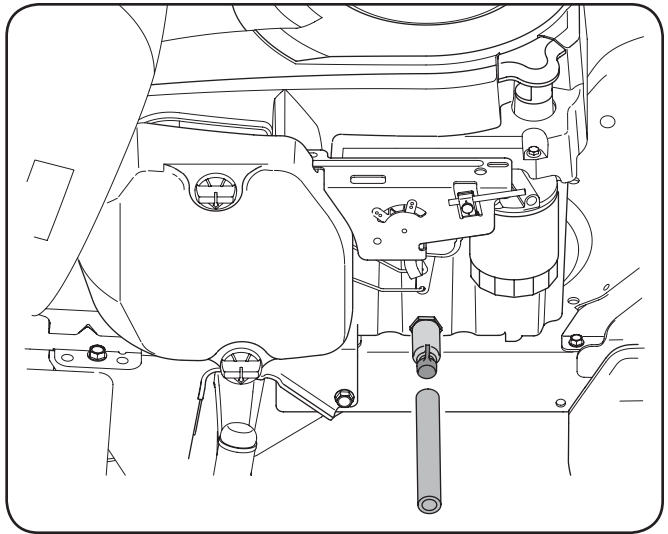

Figure 6-2

4. Remove the oil fill cap/ dipstick from the oil fill tube.
5. Push the oil drain hose (packed with this manual) onto the oil drain port. Route the opposite end of the hose into an appropriate oil collection container with at least a 2.5 quart capacity, to collect the used oil.
6. The engine is equipped with either a twist-and-pull drain port or a tabbed drain port. If your engine has the twist-and-pull drain, go to step a. If your engine is equipped with the tabbed drain, go to step b.
 - a. Turn the oil drain valve $\frac{1}{4}$ -turn, then pull outward to begin draining oil. After the oil has finished draining, push the end of the oil drain valve back in and turn $\frac{1}{4}$ -turn to secure it back in place. Re-cap the end of the oil drain valve to keep debris from entering the drain port.
 - b. Pinch the tabs on the oil drain valve, then pull outward to begin draining oil. After the oil has finished draining, push the end of the oil drain valve back in, until the tabs click into place. Re-cap the end of the oil drain valve to keep debris from entering the drain port.

7. Replace the oil filter as instructed in the Kohler Owner's Manual.
8. Refill the engine with new oil. Refer to the Engine Operator/Owner Manual packed with your unit for information regarding the quantity and proper viscosity of motor oil.

Air Cleaner

Service the pre-cleaner, if so equipped, and cartridge/air cleaner element as instructed in the Engine Operator/Owner Manual packed with your unit.

Spark Plug

The spark plug should be cleaned and the gap reset once a season. Spark plug replacement is recommended at the start of each mowing season. Refer to the Engine Operator/Owner Manual for correct plug type and gap specifications.

Lubrication



WARNING! Before lubricating, repairing, or inspecting, always disengage PTO, move shift lever into neutral position, set parking brake, stop engine and remove key to prevent unintended starting.

Engine

Lubricate the engine with motor oil as instructed in the Engine Owner Manual packed with your unit.

Pivot Points & Linkage

Lubricate all the pivot points on the drive system, parking brake and lift linkage at least once a season with light oil.

Rear Wheels

The rear wheels should be removed from the axles once a season. Lubricate the axles and the rims well with an all-purpose grease before re-installing them.

Front Axles

Each end of the tractor's front pivot bar may be equipped with a grease fitting. Lubricate with a grease gun after every 25 hours of tractor operation.

Battery

The battery is sealed and is maintenance-free. Acid levels cannot be checked.

- Always keep the battery cables and terminals clean and free of corrosive build-up.
- After cleaning the battery and terminals, apply a light coat of petroleum jelly or grease to both terminals.
- Always keep the rubber boot positioned over the positive terminal to prevent shorting.

IMPORTANT: If removing the battery for any reason, disconnect the NEGATIVE (Black) wire from its terminal first, followed by the POSITIVE (Red) wire. When re-installing the battery, always connect the POSITIVE (Red) wire its terminal first, followed by the NEGATIVE (Black) wire. Be certain that the wires are connected to the correct terminals; reversing them could change the polarity and result in damage to your engine's alternating system.

Cleaning Battery

Clean the battery by removing it from the tractor and washing with a baking soda and water solution. If necessary, scrape the battery terminals with a wire brush to remove deposits. Coat terminals and exposed wiring with grease or petroleum jelly to prevent corrosion.

Battery Failures

Some common causes for battery failure are:

- Incorrect initial activation
- Overcharging
- Freezing
- Undercharging
- Corroded connections

These failures are NOT covered by your tractor's warranty.

Cleaning the Engine And Deck

Any fuel or oil spilled on the machine should be wiped off promptly. Do NOT allow debris to accumulate around the cooling fins of the engine or on any other part of the machine.

IMPORTANT: The use of a pressure washer to clean your tractor is NOT recommended. It may cause damage to electrical components, spindles, pulleys, bearings or the engine.

A hex plug can be found on your tractor's deck surface. See Fig. 6-3.

This plug can be replaced with a water port to be used as part of a separately-available deck wash system.

The Deck Wash System™ is used to rinse grass clippings from the deck's underside and prevent the buildup of corrosive chemicals.

NOTE: Refer to the Attachments & Accessories section of this manual for information regarding this and other separately-available attachments & accessories for your tractor.

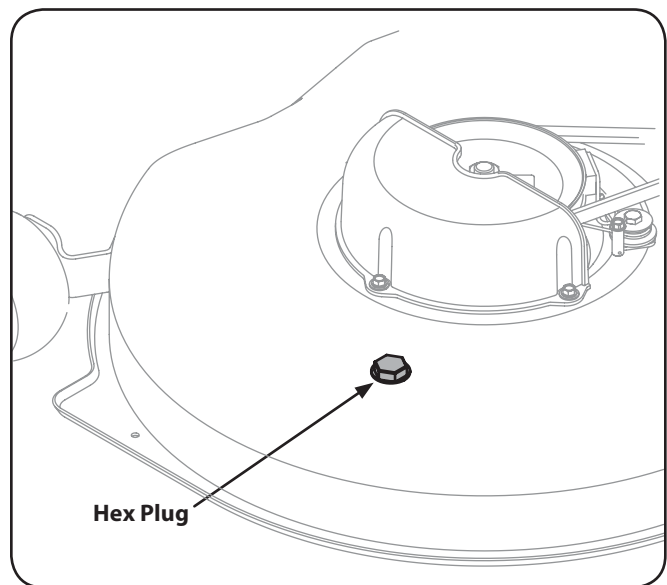

Figure 6-3

Deck Wash System™

If your tractor's deck is equipped with a water port on its surface as part of its Deck Wash System™, follow these instructions to utilize this feature.

Use the Deck Wash System™ to rinse grass clippings from the deck's underside and prevent the buildup of corrosive chemicals. Complete the following steps AFTER EACH MOWING:

1. Drive the tractor to a level, clear spot on your lawn, near enough for your garden hose to reach.



CAUTION: Make certain the tractor's discharge chute is directed AWAY from your house, garage, parked cars, etc.

2. Disengage the PTO (*Blade Engage*), set the parking brake and stop the engine.
3. Thread the hose coupler (*packaged with your tractor's Operator's Manual*) onto the end of your garden hose.
4. Attach the hose coupler to the water port on the deck's surface. See Fig. 6-4.

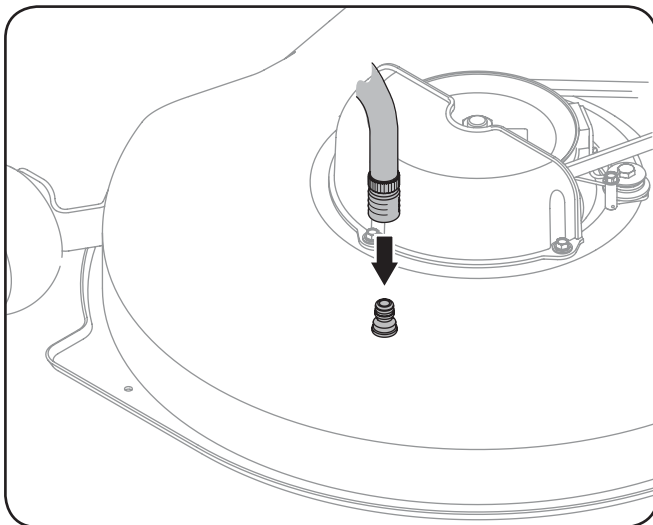

Figure 6-4

5. Turn the water on.
6. While sitting in the operator's position on the tractor, start the engine and place the throttle lever in the FAST (rabbit) position.
7. Move the tractor's PTO (*Blade Engage*) into the ON position.
8. Remain in the operator's position with the cutting deck engaged for a minimum of two minutes, allowing the underside of the cutting deck to thoroughly rinse.
9. Move the tractor's PTO (*Blade Engage*) into the OFF position.
10. Turn the ignition key to the STOP position to turn the tractor's engine off.
11. Turn the water off and detach the hose coupler from the water port on your deck's surface.
12. On 46" decks, repeat steps 4 through 11 on the opposite side of the cutting deck.

IMPORTANT: After cleaning your deck with the Deck Wash System™, return to the operator's position and engage the PTO. Keep the cutting deck running for a minimum of two minutes, allowing the underside of the cutting deck to thoroughly dry.

Adjustments



WARNING! Never attempt to make any adjustments while the engine is running, except where specified in the operator's manual.

Leveling the Deck

NOTE: Check the tractor's tire pressure before performing any deck leveling adjustments. Refer to Tires in the Service section of this manual for more information regarding tire pressure.

Front To Rear

The front of the cutting deck is supported by a stabilizer bar that can be adjusted to level the deck from front to rear. The front of the deck should be between 1/4-inch and 3/8-inch lower than the rear of the deck. Adjust if necessary as follows:

1. With the tractor parked on a firm, level surface, place the deck lift lever in the top notch (highest position) and rotate the blade nearest the discharge chute so that it is parallel with the tractor.
2. Measure the distance from the front of the blade tip to the ground and the rear of the blade tip to the ground. The first measurement taken should be between 1/4" and 3/8" less than the second measurement. Determine the approximate distance necessary for proper adjustment and proceed, if necessary, to the next step.
3. Locate the nut (s) on the front side of the stabilizer bracket. See Fig. 6-5.
For units with 2 nuts: After loosening the jam nut: Tighten the lock nut to raise the front of the deck; Loosen the lock nut to lower the front of the deck. Retighten the jam nut loosened earlier when proper adjustment is achieved.
For units with 1 nut: Tighten the nut to raise the front of the deck; Loosen the nut to lower the front of the deck.

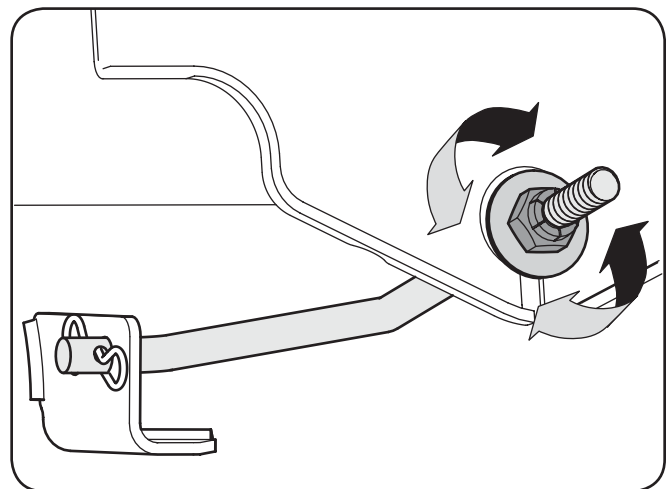

Figure 6-5

Side to Side

If the cutting deck appears to be mowing unevenly, a side to side adjustment can be performed. Adjust if necessary as follows:

1. With the tractor parked on a firm, level surface, place the deck lift lever in the top notch (*highest position*) and rotate both blades so that they are perpendicular with the tractor.
2. Measure the distance from the outside of the left blade tip to the ground and the distance from the outside of the right blade tip to the ground. Both measurements taken should be equal. If they're not, proceed to the next step.
3. Loosen, but do NOT remove, the hex cap screw on the left deck hanger bracket. See Fig. 6-6.
4. Balance the deck by using a wrench to turn the adjustment gear (*found immediately behind the hex cap screw just loosened*) clockwise/up or counterclockwise/down. The deck is properly balanced when both blade tip measurements taken earlier are equal.
5. Retighten the hex cap screw on the left deck hanger bracket when proper adjustment is achieved.

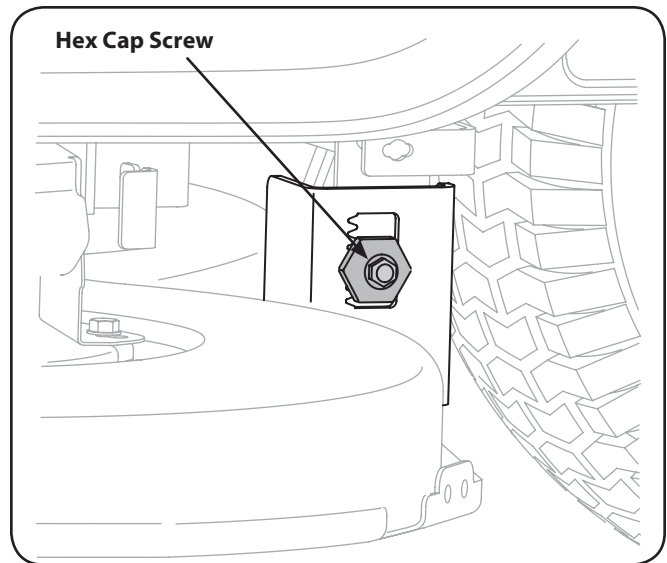

Figure 6-6

Seat Adjustment

Refer to the Set-Up and Assembly section of this manual for seat adjustment instructions.

Parking Brake Adjustment



WARNING! Never attempt to adjust the brakes while the engine is running. Always disengage PTO, move shift lever into neutral position, stop engine and remove key to prevent unintended starting.

If the tractor does not come to a complete stop when the brake pedal is completely depressed, or if the tractor's rear wheels can roll with the parking brake applied, the brake is in need of adjustment. See an authorized Service Dealer to have your brakes properly adjusted.

Maintenance Schedule

	Before Each use	Every 10 Hours	Every 25 Hours	Every 50 Hours	Every 100 Hours	Prior to Storing
Clean Hood/Dash Louvers		✓				✓
Check Engine Oil Level	✓	✓				
Check Air Filter for Dirty, Loose or Damaged Parts	✓					
Clean and Re-oil Air Filter's Foam Pre-cleaner			✓			
Replace Air Filter Element					✓	
Change Engine Oil and Replace Oil Filter				✓		
Clean Battery Terminals		✓				✓
Lube Front Axles and Rims			✓			✓
Clean Engine Cooling Fins			✓			✓
Lube Pedal Pivot Points		✓				✓
Check Spark Plug Condition & Gap					✓	✓
Replace Fuel Filter					✓	

NOTE: This Operators Manual covers a range of product specifications for various models. Characteristics and features discussed and/or illustrated in this manual may not be applicable to all models. The manufacturer reserves the right to change product specifications, designs and equipment without notice and without incurring obligation.

IMPORTANT: Since this manual covers a range of various tractor models, it is important to consult the specific engine operator's manual included with this machine for detailed engine maintenance procedures and intervals.

Cutting Deck Removal

NOTE: Models equipped with a 38-inch deck have one deck idler pulley. Models equipped with a 42- and 46-inch deck have two deck idler pulleys.

To remove the cutting deck, proceed as follows:

1. Place the PTO (*Blade Engage*) lever in the disengaged (OFF) position and engage the parking brake.
2. Lower the deck by moving the deck lift lever into the bottom notch on the right fender.
3. Removing the self-tapping screw (A) that secures the belt-keeper rod from around the tractor's engine pulley, then remove the belt keeper rod (B). See Fig. 7-1.

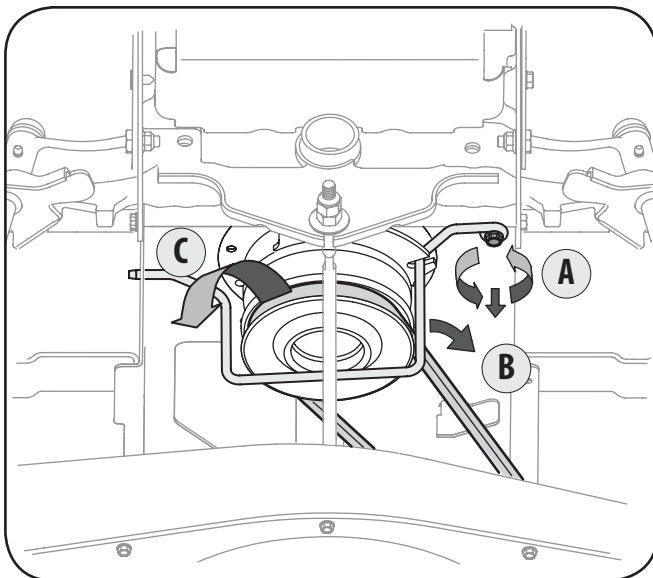

Figure 7-1

Note: Make a mental note what hole the other end of the belt-keeper rod is inserted in for reinstallation purposes.

4. Remove the belt (C) from around the tractor's engine pulley. See Fig. 7-1.



WARNING! Avoid pinching injuries. Never place your fingers on the idler spring or between the belt and a pulley while removing the belt.

5. On 38" Decks: Looking at the cutting deck from the left side of the tractor, locate the bow-tie pin that secures the deck support rod on the rear left side of the deck. See Fig. 7-2. Remove the bow-tie pin that secures the deck support rod, and carefully remove the deck support from the deck lift arm.

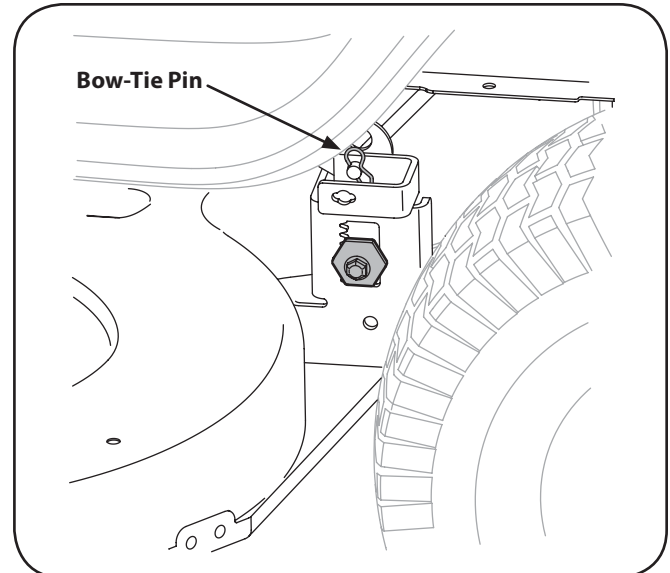

Figure 7-2

6. Repeat the above steps on the tractor's right side.

NOTE: The bow-tie hair-pin clips should be installed from the top down.

7. On 42" & 46" Decks: Looking at the cutting deck from the left side of the tractor, locate the deck support pin on the rear left side of the deck. Pull the deck support pin outward to release the deck from the deck lift arm. See Fig. 7-3.

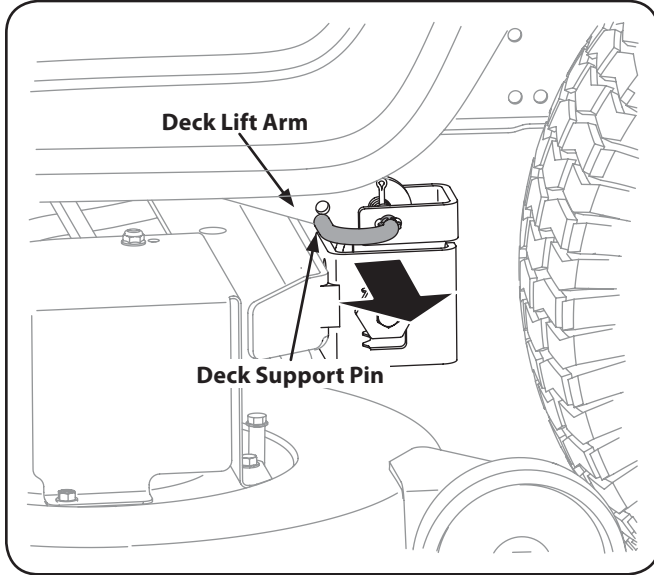

Figure 7-3

8. Repeat the above steps on the tractor's right side.
9. On all decks: Move the deck lift lever into the top notch on the right fender to raise the deck lift arms up and out of the way.
10. On 38" Decks: Gently slide the cutting deck toward the front of the tractor carefully guiding the hooks on the deck off of the deck stabilizer rod.
On 42" & 46" Decks: Remove the bow-tie cotter pin securing the deck stabilizer rod to the deck. Slide the deck lift rod from the mounting weldment on the deck as seen in Fig. 7-4.

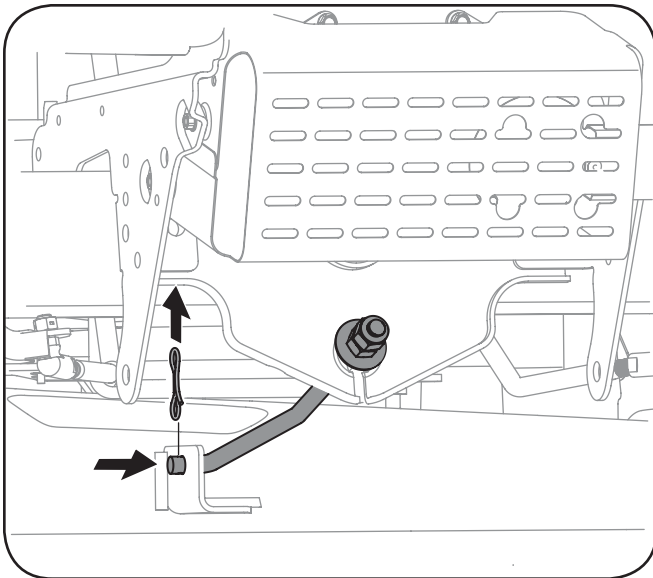

Figure 7-4

11. Carefully remove the PTO cable from the rear of the cutting deck by removing the hair pin clip which secures it. Remove the spring from the deck idler bracket. See Fig. 7-5 on the next page.

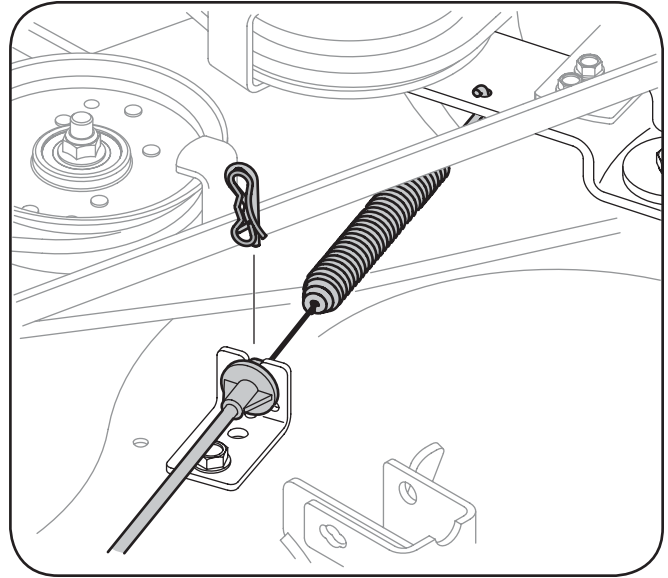

Figure 7-5

12. Gently slide the cutting deck (*from the left side*) out from underneath the tractor.

Tires



WARNING! Never exceed the maximum inflation pressure shown on the sidewall of tire.

The recommended operating tire pressure is:

- Approximately 10 psi for the rear tires
- Approximately 14 psi for the front tires

IMPORTANT: Refer to the tire sidewall for exact tire manufacturer's recommended or maximum psi. Do not overinflate. Uneven tire pressure could cause the cutting deck to mow unevenly.

Battery



CALIFORNIA PROPOSITION 65 WARNING!

Battery posts, terminals, and related accessories contain lead and lead compounds, chemicals known to the State of California to cause cancer and reproductive harm. Wash hands after handling.



CAUTION: If removing the battery, disconnect the NEGATIVE (Black) wire from its terminal first, followed by the POSITIVE (Red) wire. When re-installing the battery, always connect the POSITIVE (Red) wire its terminal first, followed by the NEGATIVE (Black) wire.

Jump Starting



WARNING! Never jump start a damaged or frozen battery. Be certain the vehicles do not touch, and ignitions are off. Do not allow cable clamps to touch.

1. Connect positive (+) cable to positive post (+) of your tractor's discharged battery.
2. Connect the other end of the cable to the (positive +) post of the jumper battery.
3. Connect the second cable (negative -) to the other post of the jumper battery.
4. Make the final connection on the engine block of the tractor, away from the battery. Attach to a unpainted part to assure a good connection.



CAUTION: If the jumper battery is installed on a vehicle (i.e. car, truck), do NOT start the vehicle's engine when jump starting your tractor.

5. Start the tractor (as instructed in the Operation section of this manual).
6. Set the tractor's parking brake before removing the jumper cables, in reverse order of connection.

Charging



WARNING! Batteries give off an explosive gas while charging. Charge the battery in a well ventilated area and keep away from an open flame or pilot light as on a water heater, space heater, furnace, clothes dryer or other gas appliances.



CAUTION: When charging your tractor's battery, use only a charger designed for 12V lead-acid batteries. Read your battery charger's Owner's Manual prior to charging your tractor's battery. Always follow its instructions and heed its warnings.

If your tractor has not been put into use for an extended period of time, charge the battery as follows:

1. Set your battery charger to deliver a max of 10 amperes.

If your battery charger is automatic, charge the battery until the charger indicates that charging is complete. If the charger is not automatic, charge for no fewer than eight hours.

Fuse

One 20 AMP fuse is installed in your tractor's wiring harness to protect the tractor's electrical system from damage caused by excessive amperage.

If the electrical system does not function, or your tractor's engine will not crank, first check to be certain that the fuse has not blown. It can be found at the rear of the unit, underneath the fender located by the battery.



WARNING! Always use a fuse with the same amperage capacity for replacement.

Cutting Blades



WARNING! Shut the engine off and remove ignition key before removing the cutting blade(s) for sharpening or replacement. Protect your hands by using heavy gloves when grasping the blade.



WARNING! Periodically inspect the blade and/or spindle for cracks or damage, especially after you've struck a foreign object. Do not operate the machine until damaged components are replaced.

To remove the blades, proceed as follows.

1. Remove the deck from beneath the tractor, (refer to Cutting Deck Removal earlier in this section) then gently flip the deck over to expose its underside.
2. Place a block of wood between the center deck housing baffle and the cutting blade to act as a stabilizer. See Fig. 7-6.
3. Remove the hex flange nut that secures the blade to the spindle assembly. See Fig. 7-6.

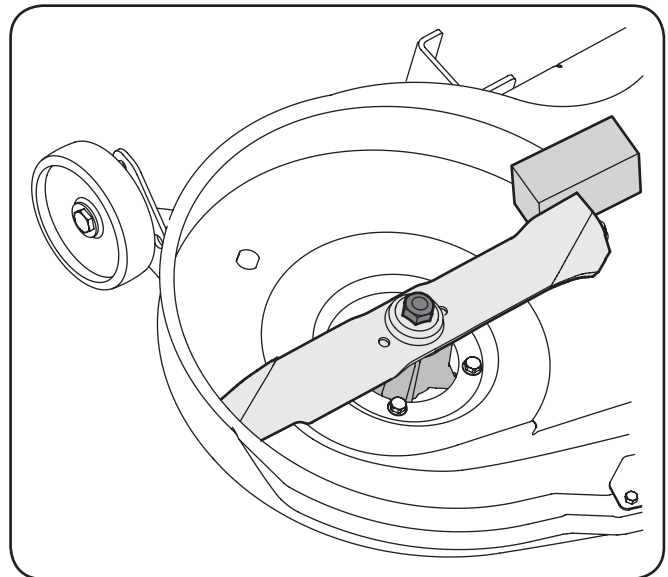

Figure 7-6

4. To properly sharpen the cutting blades, remove equal amounts of metal from both ends of the blades along the cutting edges, parallel to the trailing edge, at a 25°- to 30° angle. Always grind each cutting blade edge equally to maintain proper blade balance. See Fig. 7-7.



CAUTION: If the cutting edge of the blade has previously been sharpened, or if any metal separation is present, replace the blades with new ones.



WARNING! A poorly balanced blade will cause excessive vibration, may cause damage to the tractor and/or result in personal injury.

5. The blade can be tested by balancing it on a round shaft screwdriver. Grind metal from the heavy side until it balances evenly.

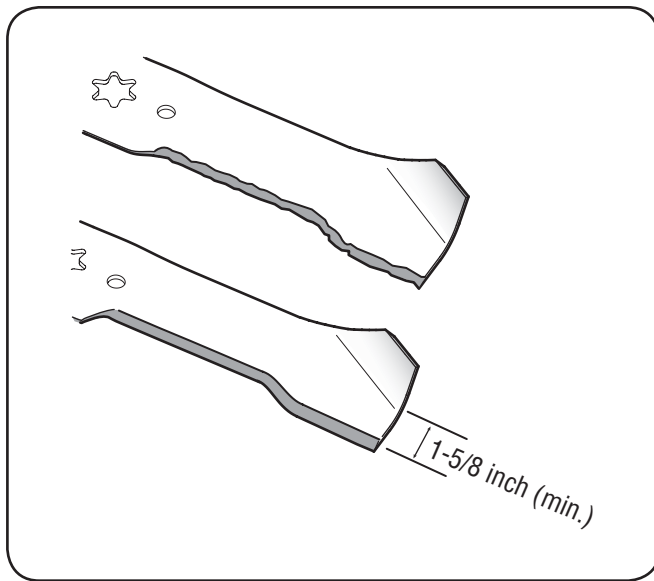

Figure 7-7

NOTE: When replacing the blade, be sure to install the blade with the side of the blade marked “Bottom” (or with a part number stamped in it) facing the ground when the mower is in the operating position.



CAUTION: Use a torque wrench to tighten the blade spindle hex flange nut to between 70 lbs-ft and 90 lbs-ft.

Changing the Deck Belt



WARNING! Be sure to shut the engine off, remove ignition key, disconnect the spark plug wire(s) and ground against the engine to prevent unintended starting before removing the belt.



WARNING! All belts on your tractor are subject to wear and should be replaced if any signs of wear are present.

IMPORTANT: The V-belt found on your tractor is specially designed to engage and disengage safely. A substitute (*non-OEM*) V-belt can be dangerous by not disengaging completely. For a proper working machine, use factory approved belts.

For 38” Decks

To change or replace the deck belt on your tractor, proceed as follows:

1. Lower the deck by moving the deck lift lever into the bottom notch on the right fender.
2. Remove the belt guards by removing the self-tapping screws that fasten them to the deck.
3. Remove the belt keeper rod from around the engine pulley.



WARNING! Avoid the possibility of a pinching injury. Do not place your fingers on the idler spring or between the belt and a pulley while removing the belt.

5. Remove the deck belt from around all pulleys, including the deck idler pulley.

6. Route the new belt as shown in and Fig. 7-9.
7. Remount the belt guards removed earlier.

For 42” & 46” Decks

To change or replace the deck belt on your tractor, proceed as follows:

1. Remove the deck as instructed earlier in this section.
2. Remove the belt covers by removing the hex washer screws that fasten them to the deck. See Fig. 7-8.

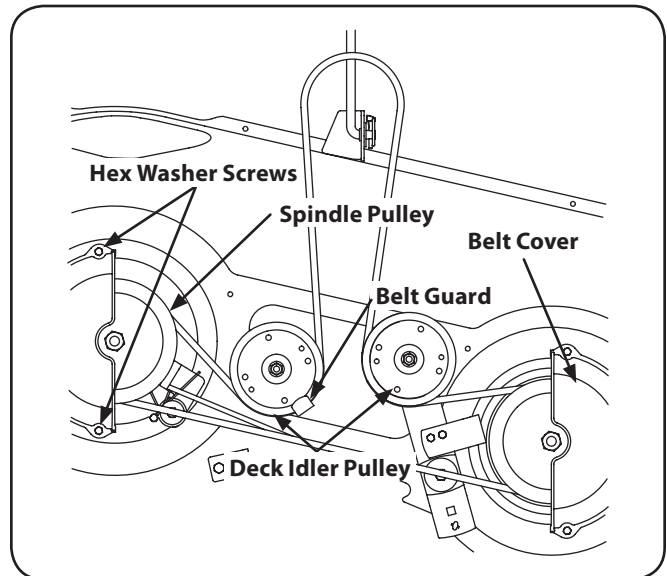

Figure 7-8

3. It may also be necessary to loosen the hex nut on the left idler pulley to get the belt off the pulley and around the belt guard.
4. Carefully remove the deck belt from around the two spindle pulleys and the two deck idler pulleys. See Fig. 7-8.
5. To place the new belt, begin by routing the belt around the two outer spindle pulleys as shown in Fig. 7-8.
6. Then route the belt around the two deck idler pulleys as shown in Fig. 7-8.
7. Retighten the belt keeper rod loosened earlier.
8. Remount the belt guards removed earlier.
9. Re-install the deck, making sure the belt remains routed around the pulleys as instructed. See Fig. 7-10.
10. Pull the right side of the belt, and place the narrow V side of the belt into the PTO pulley.
11. While holding the belt and pulley together, rotate the pulley to the left. Continue holding and rotating the pulley and belt until the belt is fully rolled into the PTO pulley.

Changing the Transmission Drive Belt

NOTE: Several components must be removed and special tools are required (i.e. air/impact wrench) in order to change the tractor’s drive belt. See an authorized MTD Service Dealer to have your drive belt replaced or contact Customer Support as instructed on page 2.

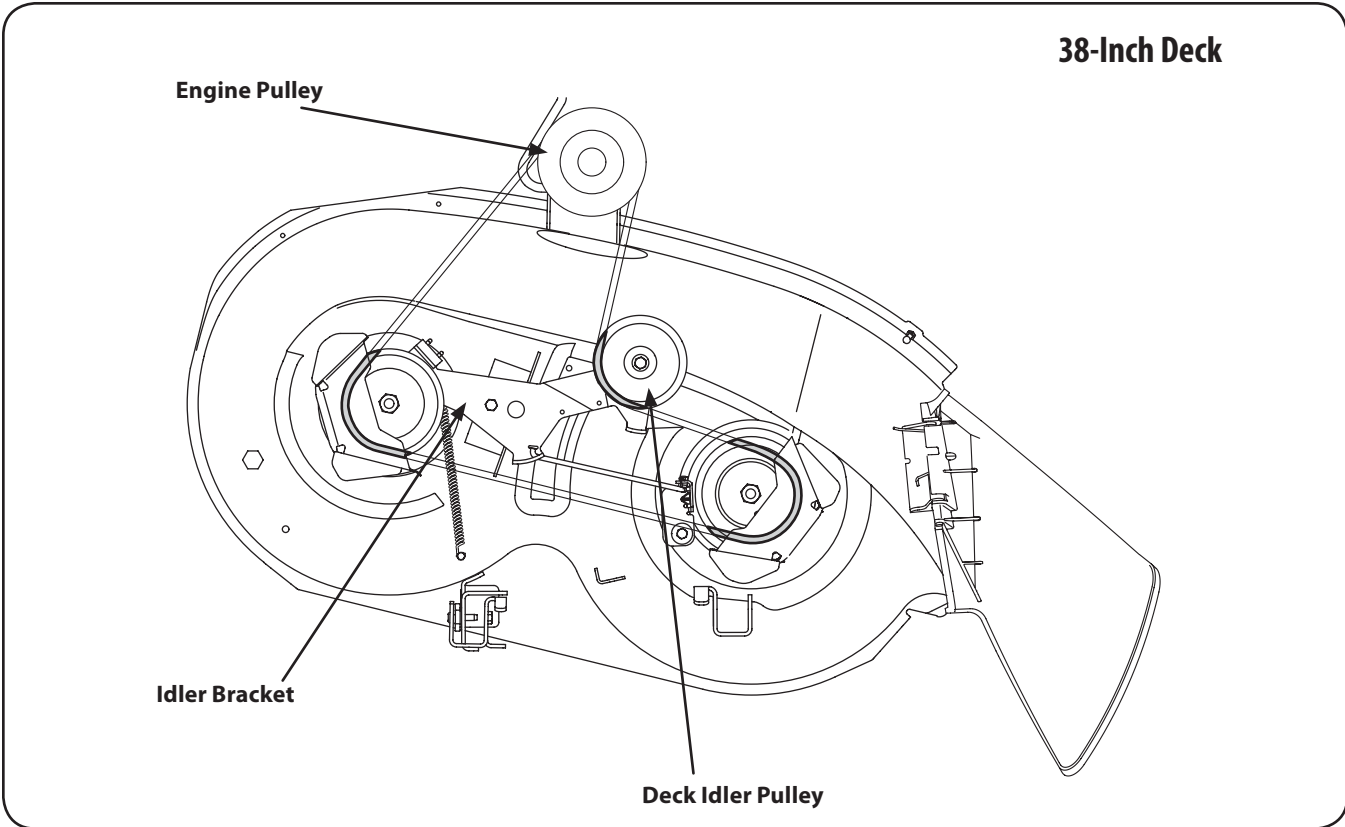

Figure 7-9

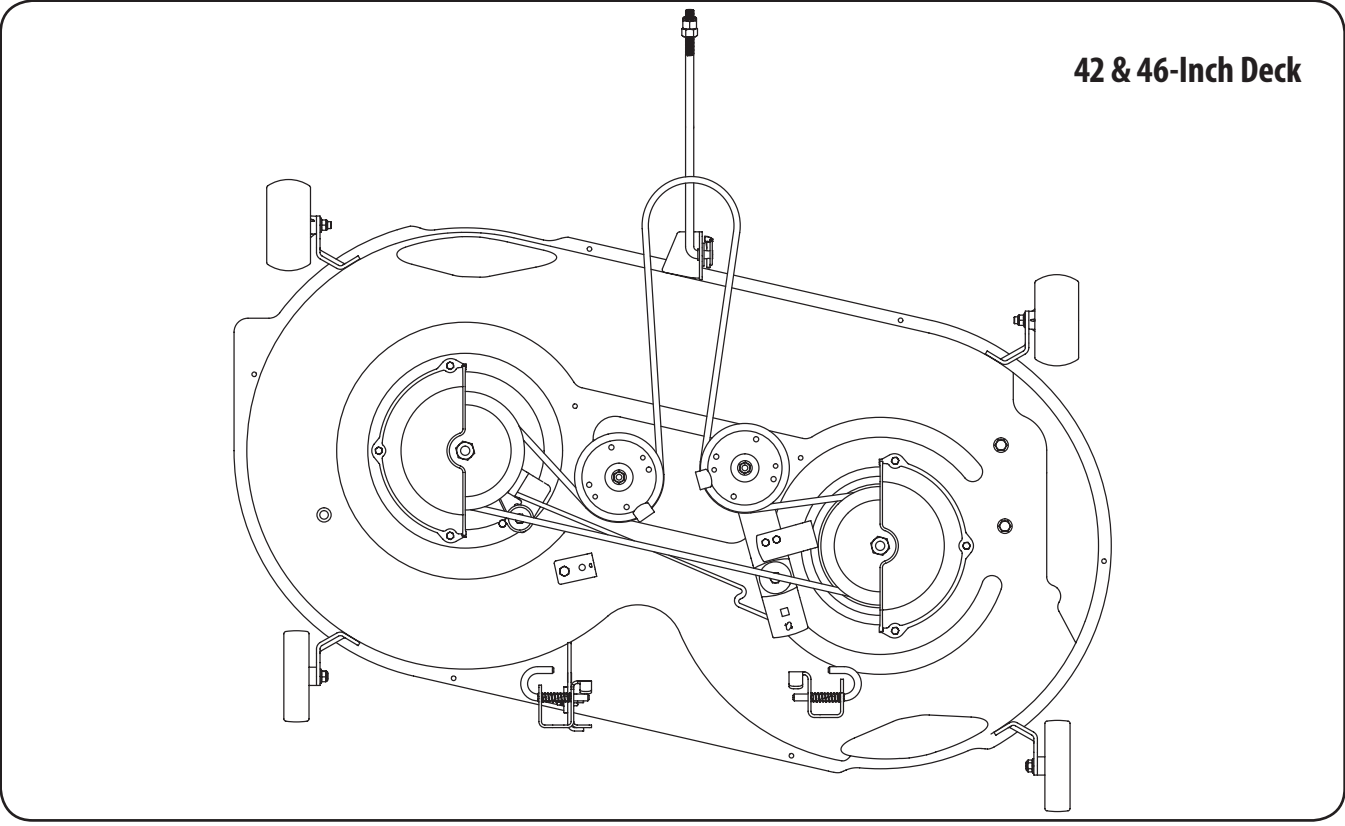

Figure 7-10

Problem	Cause	Remedy
Engine fails to start	<ol style="list-style-type: none"> 1. PTO/Blade engaged. 2. Spark plug wire disconnected. 3. Fuel tank empty, or stale fuel. 4. Choke not activated. 5. Faulty spark plug. 6. Blocked fuel line. 7. Engine flooded. 8. Parking brake not engaged 9. Throttle control lever not in correct starting position. 	<ol style="list-style-type: none"> 1. Place knob (or lever) in disengaged (OFF) position. 2. Connect wire to spark plug. 3. Fill tank with clean, fresh (less than 30 days old) gas. 4. Place the throttle control in CHOKE position. 5. Clean, adjust gap or replace plug. 6. Clean fuel line and replace fuel filter. 7. Crank engine with throttle in FAST position. 8. Engage parking brake. 9. Place throttle lever to FAST position.
Engine runs erratic	<ol style="list-style-type: none"> 1. Unit running with CHOKE activated. 2. Spark plug wires loose. 3. Blocked fuel line or stale fuel. 4. Vent in gas cap plugged. 5. Water or dirt in fuel system. 6. Dirty air cleaner. 	<ol style="list-style-type: none"> 1. Move the throttle control out of the CHOKE position. 2. Connect and tighten spark plug wire. 3. Clean fuel line; fill tank with clean, fresh gasoline and replace fuel filter, if so equipped. 4. Clear vent or replace cap if damaged. 5. Drain fuel tank. Refill with clean, fresh gasoline. 6. Replace air cleaner paper element or clean foam pre-cleaner, if so equipped.
Engine overheats	<ol style="list-style-type: none"> 1. Engine oil level low. 2. Air flow restricted. 	<ol style="list-style-type: none"> 1. Fill crankcase with proper amount and weight of oil. 2. Clean grass clippings and debris from around the engine's cooling fins and blower housing.
Engine hesitates at high RPM	<ol style="list-style-type: none"> 1. Spark plug gap too close. 	<ol style="list-style-type: none"> 1. Remove spark plug and reset the gap.
Engine Idles rough	<ol style="list-style-type: none"> 1. Spark plug fouled, faulty or gap too wide. 2. Dirty air cleaner. 	<ol style="list-style-type: none"> 1. Replace spark plug. Set plug gap. 2. Replace air cleaner element and/or clean pre-cleaner, if so equipped.
Excessive vibration	<ol style="list-style-type: none"> 1. Cutting blade loose or unbalanced. 2. Damaged or bent cutting blade. 	<ol style="list-style-type: none"> 1. Tighten blade and spindle. Balance blade. 2. Replace blade.
Mower will not mulch grass	<ol style="list-style-type: none"> 1. Engine speed too low. 2. Wet grass. 3. Excessively high grass. 4. Dull blade. 	<ol style="list-style-type: none"> 1. Place throttle in FAST (rabbit) position. 2. Do not mulch when grass is wet. 3. Mow once at a high cutting height, then mow again at desired height or make a narrower cutting swath. 4. Sharpen or replace blade.
Uneven cut	<ol style="list-style-type: none"> 1. Deck not leveled properly. 2. Dull blade. 3. Uneven tire pressure. 	<ol style="list-style-type: none"> 1. Perform side-to-side deck adjustment. 2. Sharpen or replace blade. 3. Check tire pressure in all four tires.

The following attachments and accessories are compatible for Model Series 700 Lawn Tractors. See the retailer from which you purchased your tractor, an authorized Service Dealer or phone (800) 668-1238 for information regarding price and availability.



CAUTION: Model Series 700 Lawn Tractors are NOT designed for use with any type of ground-engaging attachments (e.g. tiller or plow). Use of this type of equipment WILL void the tractor's warranty.

Model Number	Description
OEM-190-116	38-inch Deck Mulch Kit
19A30006OEM	42-inch Deck Mulch Kit
19A30005OEM	46-inch Deck Mulch Kit
OEM-190-607	Deluxe Tractor Sunshade
OEM-190-679	Bumper
OEM-190-183	Deck Wheel Kit 38"
OEM-190-180	Double Bagger Kit 38"
19A30003OEM	Double Bagger Kit 42" and 46"
490-900-0025	Deck Wash Kit

Replacement Parts

DESCRIPTION	PART NO.
Drive Belt (Mowing Deck) 38" Deck	754-04062
Drive Belt (Mowing Deck) 42" Deck	754-04060B
Drive Belt (Mowing Deck) 46" Deck	754-04219
Deck Blade (38" Deck)	742-0610A
Deck Blade (42" Deck)	742-04308
Deck Blade (46" Deck)	742-04290
Deck Spindle (38" Deck)	618-04474A
Deck Spindle (42" Deck)	618-04822A
Deck Spindle (46" Deck)	618-04865A
Battery	725-1707D
Tire (Front) 13 x 5 x 6 Round Shoulder	734-04372
Tire (Front) 15 x 6 x 6 Round Shoulder	734-04240A
Tire (Front) 15 x 6 x 6 Square Shoulder	734-1731
Tire (Rear) 18 x 6.5 x 8 Square Shoulder	734-0294
Tire (Rear) 20 x 8 x 8 Round Shoulder	734-04241
Tire (Rear) 20 x 8 x 8 Square Shoulder	734-1730
Hub Cap	731-0484A
Fuel Tank Cap	751-3111
Throttle Control/Choke Cable	746-04364
Discharge Chute Assembly 38" Deck	631-0216A
Discharge Chute Assembly 42" and 46" Deck	631-04349
Key	725-1745A

NOTE: This Operators Manual covers a range of product specifications for various models. Characteristics and features discussed and/or illustrated in this manual may not be applicable to all models. The manufacturer reserves the right to change product specifications, designs and equipment without notice and without incurring obligation.

NOTE: Download a complete Parts Manual free of charge at www.mtdproducts.com or phone (800) 668-1238 to purchase a Parts Manual. Be sure to have your model number and serial number ready. These can be found on the model plate located under the seat. Refer to page 2 for more information regarding locating your model and serial numbers.

CALIFORNIA EMISSION CONTROL WARRANTY STATEMENT
YOUR WARRANTY RIGHTS AND OBLIGATIONS

The California Air Resources Board and MTD Consumer Group Inc are pleased to explain the evaporative emission control system warranty on your 2008 lawn mower. In California, new lawn mowers must be designed, built and equipped to meet the State's stringent anti-smog standards. MTD Consumer Group Inc must warrant the EECS on your lawn mower for the period of time listed below provided there has been no abuse, neglect or improper maintenance of your lawn mower.

Your EECS may include parts such as the carburetor, fuel-injection system, the ignition system, catalytic converter, fuel tanks, fuel lines, fuel caps, valves, canisters, filters, vapor hoses, clamps, connectors, and other associated emission-related components.

Where a warrantable condition exists, MTD Consumer Group Inc will repair your lawn mower at no cost to you including diagnosis, parts and labor.

MANUFACTURER'S WARRANTY COVERAGE:

This evaporative emission control system is warranted for two years. If any evaporative emission-related part on your equipment is defective, the part will be repaired or replaced by MTD Consumer Group Inc.

OWNER'S WARRANTY RESPONSIBILITIES:

As the lawn mower owner, you are responsible for performance of the required maintenance listed in your owner's manual. MTD Consumer Group Inc recommends that you retain all receipts covering maintenance on your lawn mower, but MTD Consumer Group Inc cannot deny warranty solely for the lack of receipts.

As the lawn mower owner, you should however be aware that MTD Consumer Group Inc may deny you warranty coverage if your lawn mower or a part has failed due to abuse, neglect, or improper maintenance or unapproved modifications.

You are responsible for presenting your lawn mower to MTD Consumer Group Inc's distribution center or service center as soon as the problem exists. The warranty repairs should be completed in a reasonable amount of time, not to exceed 30 days. If you have a question regarding your warranty coverage, you should contact the MTD Consumer Group Inc Service Department.

In the U.S.A.: MTD LLC at P.O. Box 361131, Cleveland, Ohio 44136-0019, or call 1-800-800-7310 or 1-330-220-4683 or log on to our Web site at www.mtdproducts.com.

In Canada: MTD Products Limited, Kitchener, ON N2G 4J1, or call 1-800-668-1238 or log on to our Web site at www.mtdcanada.com.

GENERAL EMISSIONS WARRANTY COVERAGE:

MTD Consumer Group Inc warrants to the ultimate purchaser and each subsequent purchaser that the lawn mower is: Designed, built and equipped so as to conform with all applicable regulations; and free from defects in materials and workmanship that cause the failure of a warranted part to be identical in all material respects to that part as described in MTD Consumer Group Inc's application for certification.

The warranty period begins on the date the lawn mower is delivered to an ultimate purchaser or first placed into service. The warranty period is two years.

Subject to certain conditions and exclusions as stated below, the warranty on emission-related parts is as follows:

1. Any warranted part that is not scheduled for replacement as required maintenance in the written instructions supplied, is warranted for the warranty period stated above. If the part fails during the period of warranty coverage, the part will be repaired or replaced by MTD Consumer Group Inc according to subsection (4) below. Any such part repaired or replaced under warranty will be warranted for the remainder of the period.
2. Any warranted part that is scheduled only for regular inspection in the written instructions supplied is warranted for the warranty period stated above. Any such part repaired or replaced under warranty will be warranted for the remaining warranty period.
3. Any warranted part that is scheduled for replacement as required maintenance in the written instructions supplied is warranted for the period of time before the first scheduled replacement date for that part. If the part fails before the first scheduled replacement, the part will be repaired or replaced by MTD Consumer Group Inc according to subsection (4) below. Any such part repaired or replaced under warranty will be warranted for the remainder of the period prior to the first scheduled replacement point for the part.
4. Repair or replacement of any warranted part under the warranty provisions herein must be performed at a warranty station at no charge to the owner.
5. Notwithstanding the provisions herein, warranty services or repairs will be provided at all of our distribution centers that are franchised to service the subject engines or equipment.
6. The lawn mower owner will not be charged for diagnostic labor that is directly associated with diagnosis of a defective, emission-related warranted part, provided that such diagnostic work is performed at a warranty station.
7. MTD Consumer Group Inc is liable for damages to other engine or equipment components proximately caused by a failure under warranty of any warranted part.
8. Throughout the lawn mower warranty period stated above, MTD Consumer Group Inc will maintain a supply of warranted parts sufficient to meet the expected demand for such parts.
9. Any replacement part may be used in the performance of any warranty maintenance or repairs and must be provided without charge to the owner. Such use will not reduce the warranty obligations of MTD Consumer Group Inc.
10. Add-on or modified parts that are not exempted by the Air Resources Board may not be used. The use of any non-exempted add-on or modified parts by the ultimate purchaser will be grounds for disallowing a warranty claims. MTD Consumer Group Inc will not be liable to warrant failures of warranted parts caused by the use of a non-exempted add-on or modified part.

WARRANTED PARTS:

The repair or replacement of any warranted part otherwise eligible for warranty coverage may be excluded from such warranty coverage if MTD Consumer Group Inc demonstrates that the lawn mower has been abused, neglected, or improperly maintained, and that such abuse, neglect, or improper maintenance was the direct cause of the need for repair or replacement of the part. That notwithstanding, any adjustment of a component that has a factory installed, and properly operating, adjustment limiting device is still eligible for warranty coverage. The following emission warranty parts are covered:

- (1) Fuel Metering System
 - Cold start enrichment system (soft choke)
 - Carburetor and internal parts
 - Fuel pump
 - Fuel tank
- (2) Air Induction System
 - Air cleaner
 - Intake manifold
- (3) Ignition System
 - Spark plug(s)
 - Magneto ignition system
- (4) Exhaust System
 - Catalytic converter
 - SAI (Reed valve)
- (5) Miscellaneous Items Used in Above System
 - Vacuum, temperature, position, time sensitive valves and switches
 - Connectors and assemblies
- (6) Evaporative Control
 - Fuel hose certified for ARB evaporative emissions 2008
 - Fuel hose clamps
 - Tethered fuel cap
 - Carbon canister
 - Vapor lines

NOTE: *If you require warranty service in Canada and your product was sold by MTD Products Limited within Canada to the retailer you purchased it from in Canada then the MTD Consumer Group Inc portion of this warranty will be honored by MTD Products Limited in Canada.*

For equipment purchased in Canada only.

THREE YEAR LIMITED WARRANTY

The limited warranty set forth below is given by MTD Products Limited with respect to new merchandise purchased and used in Canada and/or its territories and possessions (either entity respectively, "MTD").

MTD warrants this product (excluding its normal wear parts as described below) against defects in material and workmanship for a period of three (3) years commencing on the date of original purchase and will, at its option, repair or replace, free of charge, any part found to be defective in materials or workmanship. This limited warranty shall only apply if this product has been operated and maintained in accordance with the Operator's Manual furnished with the product, and has not been subject to misuse, abuse, commercial use, neglect, accident, improper maintenance, alteration, vandalism, theft, fire, water, or damage because of other peril or natural disaster. Damage resulting from the installation or use of any part, accessory or attachment not approved by MTD for use with the product(s) covered by this manual will void your warranty as to any resulting damage.

Normal wear parts are warranted to be free from defects in material and workmanship for a period of thirty (30) days from the date of purchase. Normal wear parts include, but are not limited to items such as: batteries, belts, blades, blade adapters, grass bags, rider deck wheels, seats, snow thrower skid shoes, friction wheels, shave plates, auger spiral rubber, tires, engine oil, air filters and spark plugs.

HOW TO OBTAIN SERVICE: Warranty service is available, WITH PROOF OF PURCHASE, through your local authorized service dealer. To locate the dealer in your area contact MTD Products Limited, Kitchener, ON N2G 4J1, or call 1-800-668-1238 or log on to our Web site at www.mtdcanada.com.

This limited warranty does not provide coverage in the following cases:

- a. The engine or component parts thereof. These items may carry a separate manufacturer's warranty. Refer to applicable manufacturer's warranty for terms and conditions. The Powermore engine is not excluded under this agreement.
- b. Log splitter pumps, valves, and cylinders have a separate one-year warranty.
- c. Routine maintenance items such as lubricants, filters, blade sharpening, tune-ups, brake adjustments, clutch adjustments, deck adjustments, and normal deterioration of the exterior finish due to use or exposure.
- d. Service completed by someone other than an authorized service dealer.
- e. MTD does not extend any warranty for products sold or exported outside of Canada, including possessions and territories.
- f. Replacement parts that are not genuine MTD parts.
- g. Transportation charges and service calls.
- h. If Products are used commercially. (MTD may separately offer Limited Commercial Warranties on certain select products. Ask your dealer or retailer for details or contact MTD Service for more information.)

No implied warranty, including any implied warranty of merchantability of fitness for a particular purpose, applies after the applicable period of express written warranty above as to the parts as identified. No other express warranty, whether written or oral, except as mentioned above, given by any person or entity, including a dealer or retailer, with respect to any product, shall bind MTD. During the period of the warranty, the exclusive remedy is repair or replacement of the product as set forth above.

The provisions as set forth in this warranty provide the sole and exclusive remedy arising from the sale. MTD shall not be liable for incidental or consequential loss or damage including, without limitation, expenses incurred for substitute or replacement lawn care services or for rental expenses to temporarily replace a warranted product.

Some jurisdictions do not allow the exclusion or limitation of incidental or consequential damages, or limitations on how long an implied warranty lasts, so the above exclusions or limitations may not apply to you.

In no event shall recovery of any kind be greater than the amount of the purchase price of the product sold. **Alteration of safety features of the product shall void this warranty.** You assume the risk and liability for loss, damage, or injury to you and your property and/or to others and their property arising out of the misuse or inability to use the product.

This limited warranty shall not extend to anyone other than the original purchaser or to the person for whom it was purchased as a gift.

HOW LOCAL LAWS RELATE TO THIS WARRANTY: This limited warranty gives you specific legal rights, and you may also have other rights that vary in different jurisdictions.

IMPORTANT: Owner must present Original Proof of Purchase to obtain warranty coverage.

MTD Products Ltd., P. O. BOX 1386, KITCHENER, ON N2G 4J1; Phone: 1-800-668-1238

08.08.08

For equipment purchased in United States only.

**CONSUMER'S WARRANTY
COLUMBIA OUTDOOR
THREE YEARS- 120 Hrs. LIMITED WARRANTY**

For three (3) years-120 hrs. whichever come first, from the date of original purchase of COLUMBIA products, COLUMBIA will either repair or replace, at its option, free of charge, F.O.B. factory or authorized service firm, any part found to be defective in material and workmanship. All transportation charges on parts submitted for replacement under this warranty must be paid by the purchaser unless return is requested by COLUMBIA.

This warranty DOES NOT apply to any part which has become inoperative through misuse, excessive use, accident, neglect, improper maintenance or alterations by unauthorized persons.

This limited warranty does not extend to the replacement of parts which are not defective, but where regular usage has exhausted the life of the part.

TRACTOR ATTACHMENT WARRANTY

Mower decks included with, or sold separately, as an attachment for COLUMBIA garden tractors will be warranted according to the above terms of the COLUMBIA THREE (3) YEARS - 120 hrs. limited consumer warranty.

ALL OTHER ATTACHMENTS will be sold under the same conditions as above except the warranty will be ONE YEAR FROM DATE OF ORIGINAL PURCHASE.

ENGINES, ELECTRIC START KITS, HYDRO-GEAR, PEERLESS TRANSMISSIONS AND PEERLESS TRANSAXLES ARE WARRANTED BY THEIR RESPECTIVE MANUFACTURER. ALL CLAIMS AGAINST THESE COMPONENTS MUST BE HANDLED THROUGH THE RESPECTIVE MANUFACTURERS SERVICE DEALERS.

Belts, light bulbs, clutch parts (friction wheels), grass bags, tires, seats, rider deck wheels and cutting blades are covered by a 60 day limited warranty.

Batteries are warranted against defect for 90 days at 100% of their value and 50% of their value for the period between the 91st day and the 120th day.

Fuses, shear bolts and blade adapters are considered consumable items and as such are not warranted.

Note: Regular maintenance replacement parts and related inspections and adjustments are excluded from coverage when made as part of normal maintenance service.

EXTERIOR FINISH

NORMAL DETERIORATION OF THE EXTERIOR FINISH DUE TO USE OR EXPOSURE TO THE ELEMENTS, CORROSIVE PRODUCTS ETC... IS NOT WARRANTED. LABELS ARE COVERED FOR 1 YEAR FROM THE ORIGINAL DATE OF PURCHASE.

PERSONAL USE

THE FOREGOING PARAGRAPHS CONSTITUTE COLUMBIA'S ENTIRE WARRANTY WITH RESPECT TO ANY PRODUCT PURCHASED AND USED FOR PERSONAL, FAMILY, HOUSEHOLD/RESIDENTIAL PURPOSES, AS DISTINGUISHED FROM COMMERCIAL USAGE.

COMMERCIAL USE

ALL APPLICATIONS OTHER THAN PERSONAL USE AS OUTLINED ABOVE, ARE CONSIDERED COMMERCIAL USAGE.

COLUMBIA products purchased by a company or used for commercial purposes are not covered by any warranty.

WARRANTY SERVICE CAN ONLY BE PERFORMED BY AN AUTHORIZED COLUMBIA SERVICE DEALER. ANY NON-ORIGINAL EQUIPMENT REPLACEMENT PART USED ON OR IN A PRODUCT UNDER WARRANTY WILL BE EXCLUDED FROM THAT WARRANTY COVERAGE, AS WILL BE ANY RELATED DAMAGED COMPONENTS RESULTING FROM THE INSTALLATION OF A NON-COLUMBIA REPLACEMENT PART.

MTD LLC, P.O. BOX 361131 CLEVELAND, OHIO 44136-0019; Phone: 1-800-800-7310, 1-330-220-4683

1.07.10

Notes
