

**VRV SYSTEM****Air Conditioners**

English

Deutsch

Français

Español

Italiano

Ελληνικά

Nederlands

Portugues

Русский

Türkçe

MODELS  
(Ceiling Suspended type)

**FXHQ32AVEB**  
**FXHQ63AVEB**  
**FXHQ100AVEB**

CAREFULLY READ THESE INSTRUCTIONS BEFORE INSTALLATION.  
KEEP THIS MANUAL IN A HANDY PLACE FOR FUTURE REFERENCE.

LESEN SIE DIESE HINWEISE VOR DER INSTALLATION SORGFÄLTIG DURCH.  
BEWAHREN SIE DIESE ANLEITUNG AN EINEM LEICHT ZUGÄNGLICHEN ORT FÜR SPÄTERES  
NACHSCHLAGEN AUF.

VEUILLEZ LIRE ATTENTIVEMENT CES INSTRUCTIONS AVANT L'INSTALLATION.  
CONSERVEZ CE MANUEL EN LIEU SÛR POUR POUVOIR VOUS Y REPORTER ULTÉRIEURE-  
MENT.

LEA DETENIDAMENTE ESTAS INSTRUCCIONES ANTES DE LA INSTALACIÓN  
CONSERVE ESTE MANUAL PARA POSIBLES CONSULTAS FUTURAS.

PRIMA DELL'INSTALLAZIONE, LEGGERE ATTENTAMENTE LE PRESENTI ISTRUZIONI.  
CONSERVARE IL PRESENTE MANUALE IN UN LUOGO FACILMENTE ACCESSIBILE PER RIFERI-  
MENTO FUTURO.

ΔΙΑΒΑΣΤΕ ΠΡΟΣΕΚΤΙΚΑ ΑΥΤΕΣ ΤΙΣ ΟΔΗΓΙΕΣ ΠΡΙΝ ΤΗΝ ΕΓΚΑΤΑΣΤΑΣΗ  
ΦΥΛΑΞΤΕ ΑΥΤΟ ΤΟ ΕΓΧΕΙΡΙΔΙΟ ΣΕ ΒΟΛΙΚΟ ΜΕΡΟΣ ΓΙΑ ΜΕΛΛΟΝΤΙΚΗ ΑΝΑΦΟΡΑ.

LEES DEZE INSTRUCTIES ZOGVULDIG DOOR VOORDAT MET DE INSTALLATIE WORDT BEGON-  
NEN.  
BEWAAR DEZE HANDLEIDING VOOR TOEKOMSTIG GEBRUIK OP EEN GESCHIKTE PLAATS  
ONDER HANDBEREIK.

LEIA ATENTAMENTE ESTAS INSTRUÇÕES ANTES DA INSTALAÇÃO.  
MANTENHA ESTE MANUAL NUM LOCAL DE FÁCIL ACESSO PARA CONSULTA.

ПЕРЕД УСТАНОВКОЙ ВНИМАТЕЛЬНО ПРОЧИТАЙТЕ ДАННЫЕ ИНСТРУКЦИИ.  
ХРАНИТЕ ДАННОЕ РУКОВОДСТВО В ЛЕГКО ДОСТУПНОМ МЕСТЕ ДЛЯ ЕГО ПОСЛЕДУЮЩЕГО  
ИСПОЛЬЗОВАНИЯ.

MONTAJDAN ÖNCE BU YÖNERGELERİ DİKKATLİCE OKUYUN.  
DAHA SONRA BAKMAK ÜZERE BU KILAVUZU SAKLAYIN.

## CONTENTS

1. SAFETY PRECAUTIONS .....	1
2. BEFORE INSTALLATION .....	3
3. SELECTION OF INSTALLATION LOCATION .....	5
4. PREPARATION BEFORE INSTALLATION .....	6
5. INSTALLATION OF THE INDOOR UNIT .....	8
6. REFRIGERANT PIPING WORK .....	9
7. DRAIN PIPING WORK.....	14
8. ELECTRIC WIRING WORK.....	17
9. MOUNTING SUCTION GRILLE · DECORATION SIDE PANEL.....	24
10. FIELD SETTING AND TEST OPERATION.....	24
11. WIRING DIAGRAM .....	26

The original instructions are written in English. All other languages are translations of the original instructions.

### 1. SAFETY PRECAUTIONS

Be sure to follow this “SAFETY PRECAUTIONS”.

This product comes under the term “appliances not accessible to the general public”.

This is a class A product. In a domestic environment this product may cause radio interference in which case the user may be required to take adequate measures.

- This manual classifies the precautions into WARNINGS and CAUTIONS.  
Be sure to follow all the precautions below: They are all important for ensuring safety.

 **WARNING** ..... Indicates a potentially hazardous situation which, if not avoided, could result in death or serious injury.

 **CAUTION** ..... Indicates a potentially hazardous situation which, if not avoided, may result in minor or moderate injury.  
It may also be used to alert against unsafe practices.

- After the installation is completed, test the air conditioner and check if the air conditioner operates properly. Give the user adequate instructions concerning the use and cleaning of the indoor unit according to the Operation Manual.  
Ask the user to keep this manual and the Operation Manual together in a handy place for future reference.

---

#### **WARNING**

- Ask your local dealer or qualified personnel to carry out installation work.  
Improper installation may result in water leakage, electric shocks or a fire.
- Perform installation work in accordance with this installation manual.  
Improper installation may result in water leakage, electric shocks or a fire.
- Consult your dealer regarding what to do in case of refrigerant leakage.  
When the air conditioner is installed in a small room, it is necessary to take proper measures so that the amount of any leaked refrigerant does not exceed the concentration limit in the event of a leakage.  
Otherwise, this may lead to an accident due to oxygen deficiency.

- Be sure to use only the specified parts and accessories for installation work.  
Failure to use the specified parts may result in the air conditioner falling down, water leakage, electric shocks, a fire, etc.
- Install the air conditioner on a foundation that can withstand its mass.  
Insufficient strength may result in the air conditioner falling down and causing injury.  
In addition, it may lead to vibration of indoor units and cause unpleasant chattering noise.
- Carry out the specified installation work in consideration of strong winds, typhoons, or earthquakes.  
Improper installation may result in an accident such as air conditioner falling.
- Make certain that all electrical work is carried out by qualified personnel according to the applicable legislation (note 1) and this installation manual, using a separate circuit.  
In addition, even if the wiring is short, make sure to use a wiring that has sufficient length and never connect additional wiring to make the length sufficient.  
Insufficient capacity of the power supply circuit or improper electrical construction may lead to electric shocks or a fire.  
(note 1) applicable legislation means “All international, national and local directives, laws, regulations and/or codes which are relevant and applicable for a certain product or domain”.
- Earth the air conditioner.  
Do not connect the earth wiring to gas or water piping, lightning conductor or telephone earth wiring.  
Incomplete earthing may cause electric shocks or a fire.
- Be sure to install an earth leakage breaker.  
Failure to do so may cause electric shocks and a fire.
- Disconnect the power supply before touching the electric components.  
If you touch the live part, you may get an electric shocks.
- Make sure that all wiring is secure, using the specified wirings and ensuring that external forces do not act on the terminal connections or wirings.  
Incomplete connection or fixing may cause an overheat or a fire.
- When wiring between the indoor and outdoor units, and wiring the power supply, form the wirings orderly so that the control box lid can be securely fastened.  
If the control box lid is not in place, overheat of the terminals, electric shocks or a fire may be caused.
- If refrigerant gas leaks during installation work, ventilate the area immediately.  
Toxic gas may be produced if refrigerant gas comes into contact with a fire.
- After completing the installation work, check to make sure that there is no leakage of refrigerant gas.  
Toxic gas may be produced if refrigerant gas leaks into the room and comes into contact with a source of a fire, such as a fan heater, stove or cooker.
- Never directly touch any accidental leaking refrigerant. This could result in severe wounds caused by frostbite.

## CAUTION

- Install drain piping according to this installation manual to ensure good drainage, and insulate the piping to prevent condensation.  
Improper drain piping may cause water leakage, make the furniture get wet.
- Install the air conditioner, power supply wiring, remote controller wiring and transmission wiring at least 1 meter away from televisions or radios to prevent image interference or noise.  
(Depending on the radio waves, a distance of 1 meter may not be sufficient to eliminate the noise.)
- Install the indoor unit as far as possible from fluorescent lamps.  
If a wireless remote controller kit is installed, the transmission distance may be shorter in a room where an electronic lighting type (inverter or rapid start type) fluorescent lamp is installed.
- Do not install the air conditioner in places such as the following:
  1. Where there is mist of oil, oil spray or vapour for example a kitchen.  
Resin parts may deteriorate, and cause them to fall out or water to leak.
  2. Where corrosive gas, such as sulfurous acid gas, is produced.  
Corrosion of copper pipings or brazed parts may cause the refrigerant to leak.
  3. Where there is machinery which emits electromagnetic waves.  
Electromagnetic waves may disturb the control system, and cause malfunction of the equipment.
  4. Where flammable gases may leak, where carbon fibre or ignitable dust is suspended in the air or where volatile flammables, such as thinner or gasoline, are handled.  
If the gas should leak and remained around the air conditioner, it may cause ignition.
- The air conditioner is not intended for use in a potentially explosive atmosphere.

## 2. BEFORE INSTALLATION



When unpacking and moving the indoor unit after unpacked, do not apply force to the piping (refrigerant and drain) and resin parts.





- Make sure to check in advance that the refrigerant to be used for installation work is R410A. (The air conditioner will not properly operate if a wrong refrigerant is used.)
- For installation of the outdoor unit, refer to the installation manual attached to the outdoor unit.
- Do not throw away the accessories until the installation work is completed.
- After the indoor unit is carried into the room, to avoid the indoor unit from getting damaged, take measures to protect the indoor unit with packing materials.
  - (1) Determine the route to carry the unit into the room.
  - (2) Do not unpack the unit until it is carried to the installation location.
 

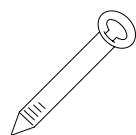

Where unpacking is unavoidable, use a sling of soft material or protective plates together with a rope when lifting, to avoid damage or scratches to the indoor unit.
- Have the customer actually operate the air conditioner while looking at the operation manual. Instruct the customer how to operate the air conditioner (particularly cleaning of the air filters, operation procedures, and temperature adjustment).
- For selection of installation location, use the installation pattern paper (used in common with the packing case.) as reference.
- Do not use the air conditioner where in the salty atmosphere such as coastal areas, vehicles, vessels or the voltage fluctuation is frequent such as factories.
- Take off static electricity from the body when carrying out wiring and the control box lid is removed. The electric parts may be damaged.

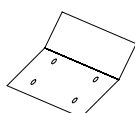
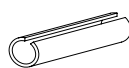
### 2-1 ACCESSORIES

Check if the following accessories are attached to the indoor unit.

Name	(1) Drain hose	(2) Metal clamp	(3) Washer for hanger	(4) Clamp
Quantity	1 pc.	1 pc.	8 pcs.	7 pcs.
Shape				

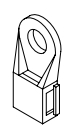
Name	(5) Installation pattern paper	Joint insulating material	Sealing material	(10) Resin bushing
Quantity	1 sheet	1 each	1 each	1 pc.
Shape		(6) For gas piping  (7) For liquid piping 	(8) Large  (9) Small 	

Name	(11) Wiring fixture	(12) Screw for wiring fixture	(Miscellaneous)
Quantity	2 pcs.	2 pcs.	
Shape		M4 × 12 	

## 2-2 OPTIONAL ACCESSORIES

- For this indoor unit, the remote controller is separately required.
- There are 2 kinds of remote controller; wired type and wireless type.  
Install the remote controller to the place where the customer has given consent.  
Refer to the catalog for the applicable model.  
(Refer to the installation manual attached to the remote controller for how to install.)

### **CARRY OUT THE WORK GIVING CAUTION TO THE FOLLOWING ITEMS AND AFTER THE WORK IS COMPLETED CHECK THESE AGAIN.**

#### **1. Items to be checked after the installation work is completed**

Items to be checked	In case of defective	Check column
Are the indoor and outdoor units rigidly fixed?	Drop · vibration · noise	
Are the installation work of the outdoor and indoor units complete?	Does not operate · burnout	
Have you carried out a leakage test with the test pressure specified in the outdoor unit installation manual?	Does not cool / Does not heat	
Is the insulation of refrigerant piping and drain piping completely carried out?	Water leakage	
Does the drain flow out smoothly?	Water leakage	
Is the power supply voltage identical to that stated in the manufacturer's label on the air conditioner?	Does not operate · burnout	
Are you sure that there is no wrong wiring or piping or no loose wiring?	Does not operate · burnout	
Is earthing completed?	Danger in case of leakage	
Are the sizes of electric wiring according to the specification?	Does not operate · burnout	
Is any of air outlets or inlets of the indoor and outdoor units blocked with obstacles? (It may lead to capacity drop due to fan speed drop or malfunction of equipment.)	Does not cool / Does not heat	
Have you recorded the refrigerant piping length and the refrigerant charge added?	Refrigerant charge amount is not clear	

Make sure to recheck the items of "SAFETY PRECAUTIONS".

#### **2. Items to be checked at delivery**

Items to be checked	Check column
Have you carried out field setting? (if necessary)	
Are the control box lid, the air filter and the suction grille attached?	
Does the cool air discharge during the cooling operation and the warm air discharge during heating operation?	
Have you explained how to operate the air conditioner showing the operation manual to the customer?	
Have you explained the description of cooling, heating, program dry and automatic (cooling/heating) given in the operation manual to the customer?	
If you set the fan speed at thermostat OFF, did you explain the set fan speed to the customer?	
Have you handed the operation manual and the installation manual to the customer?	

## Points of the operation explanation

In addition to the general usage, since the items in the operation manual with the **⚠ WARNING** and **⚠ CAUTION** marks are likely to result in human bodily injuries and property damages, it is necessary not only to explain these items to the customer but also to have the customer read them. It is also necessary to explain the items of “NOT MALFUNCTION OF THE AIR CONDITIONER” to the customer and have the customer read them carefully.

## 3. SELECTION OF INSTALLATION LOCATION

When unpacking and moving the indoor unit after unpacked, do not apply force to the piping (refrigerant and drain) and resin parts.

(1) Select the installation location that meets the following conditions and get approval of the customer.

- Where the cool and warm air spreads evenly in the room.
- Where there is no obstacles in the air passage.
- Where drainage can be ensured.
- Where the ceiling lower surface is not remarkably inclined.
- Where there is sufficient strength to withstand the mass of the indoor unit. (If the strength is insufficient, the indoor unit may vibrate and get in contact with the ceiling and generate unpleasant chattering noise.)
- Where a space sufficient for installation and service can be ensured. (Refer to Fig. 1 and Fig. 2)
- Where the piping length between the indoor and the outdoor units is ensured within the allowable length. (Refer to the installation manual attached to the outdoor unit.)
- Where there is no risk of flammable gas leak.

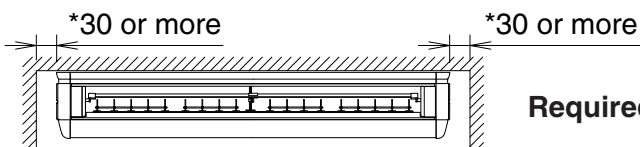

Fig. 1

Required installation space (mm)

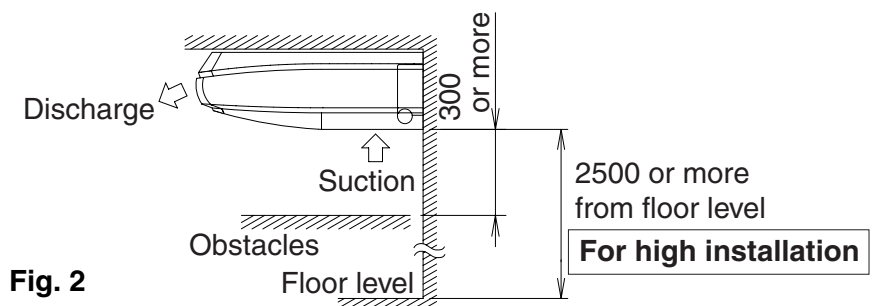

Fig. 2

### NOTE

- If there is extra space required for \* part, servicing can be conducted more easily if 200mm or more is secured.

### **⚠ CAUTION**

- Install the indoor and outdoor units, power supply wiring, remote controller wiring and transmission wiring at least 1 meter away from televisions or radios to prevent image interference or noise. (Depending on the radio waves, a distance of 1 meter may not be sufficient to eliminate the noise.)
- Install the indoor unit as far as possible from fluorescent lamps. If a wireless remote controller kit is installed, the transmission distance may be shorter in a room where an electronic lighting type (inverter or rapid start type) fluorescent lamp is installed.

(2) Use hanging bolts for installation.

Investigate if the installation place can withstand the mass of the indoor unit and, if necessary, hang the indoor unit with bolts after it is reinforced by beams etc. (Refer to the installation pattern paper (5) for the mounting pitch.)

(3) Ceiling height

This indoor unit can be installed up to 4.3m (for 32-63 model, 3.5m) of the ceiling.

## 4. PREPARATION BEFORE INSTALLATION

(1) For the locations of indoor unit hanging bolts, piping outlet holes, drain piping outlet hole, and electric wiring inlet hole. (Refer to Fig. 3)

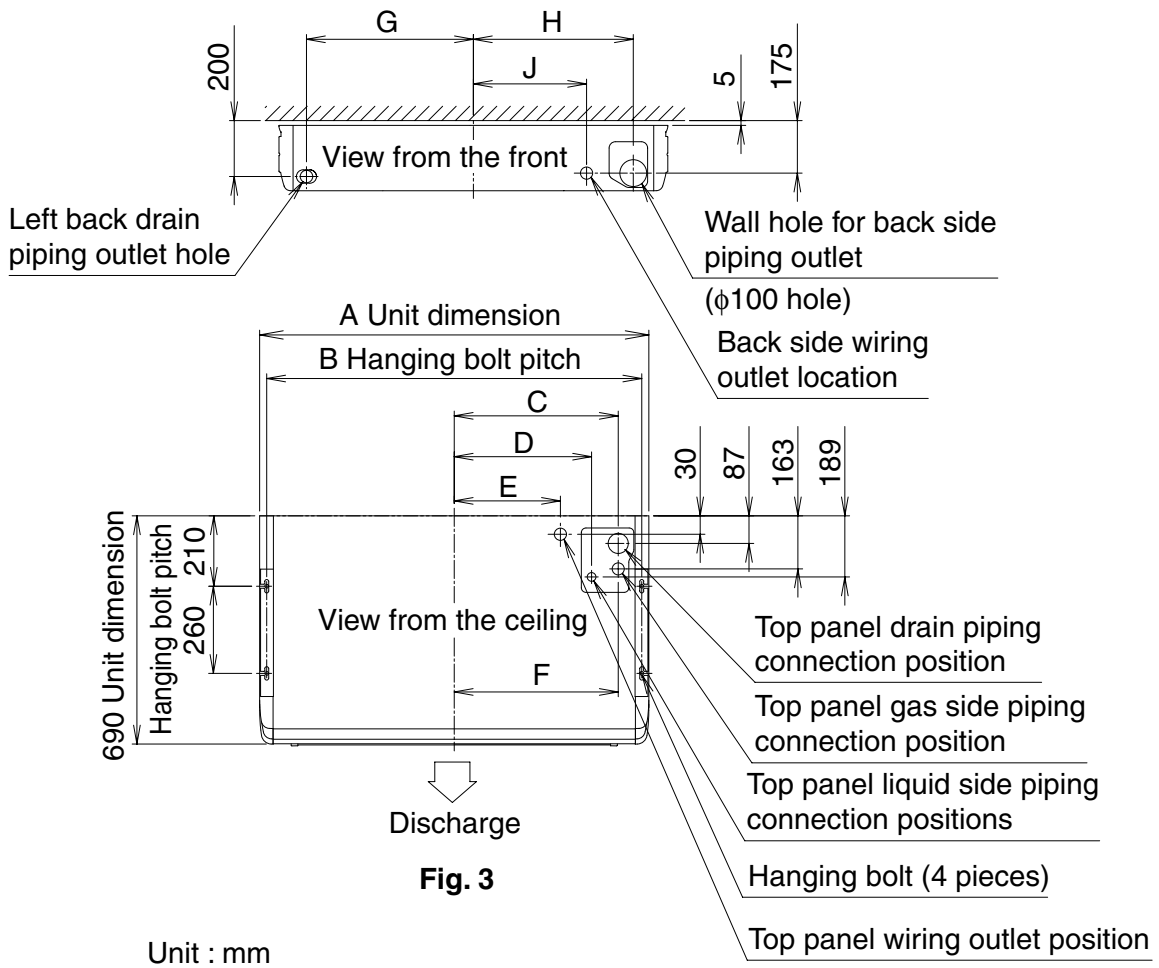

**Fig. 3**

Unit : mm

Model name (FXHQ-)	A	B	C	D	E	F	G	H	J
Type 32	960	920	378	324	270	375	398	377	260
Type 63	1270	1230	533	479	425	530	553	532	415
Type 100	1590	1550	693	639	585	690	713	692	575

(2) Make holes for hanging bolts, piping outlet, drain piping outlet and electric wiring inlet.

- Use the installation pattern paper (5).
- Determine the locations of hanging bolts, piping outlet, drain piping outlet, and electric wiring inlet. And make the hole.

### (3) Remove the parts of the indoor unit.

#### 1) Remove the suction grille.

- Slide the suction grille fixing knobs (32 type: 2 places for each, 63, 100 type: 3 places for each) toward backward direction (as shown by an arrow) to open the suction grille widely. **(Refer to Fig. 4)**
- Keeping the suction grille opened, hold the knob at the back of the suction grille and at the same time, pull the suction grille forward to remove. **(Refer to Fig. 5)**

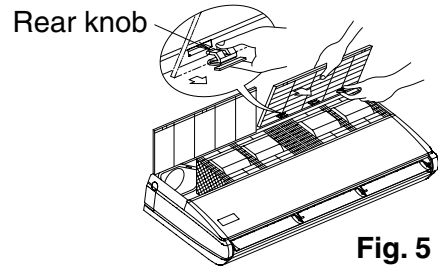
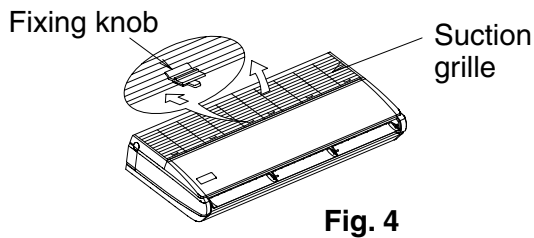

#### 2) Remove the decoration side panel (right, left).

- Remove the fixture screw of the decoration side panel (one for each), pull forward (arrow direction) to remove. **(Refer to Fig. 6)**
- Take out accessories. **(Refer to Fig. 6)**
- Open the knock hole at the wiring inlet side at the rear surface or top surface, and install the attached resin bushing (10).

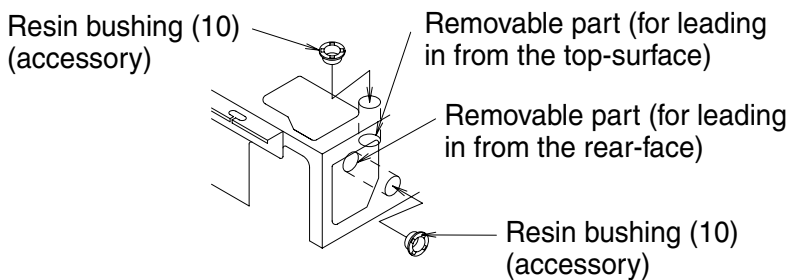
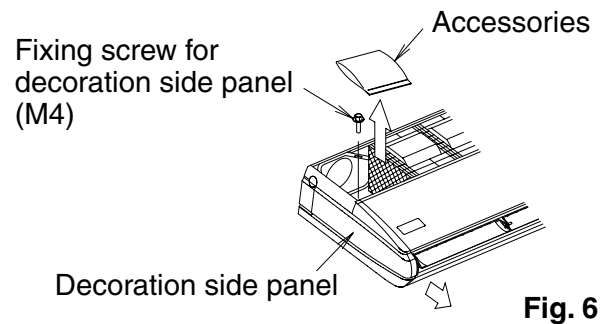

#### 3) Remove the hanger.

- Loosen 2 bolts for installing the hanger at both sides (M8) (4 places at left and right) within 10mm. **(Refer to Fig. 7 and 8)**
- Remove the fixture screw for hanger at the back side (M5), pull the hanger backward (the arrow direction) to remove. **(Refer to Fig. 8)**

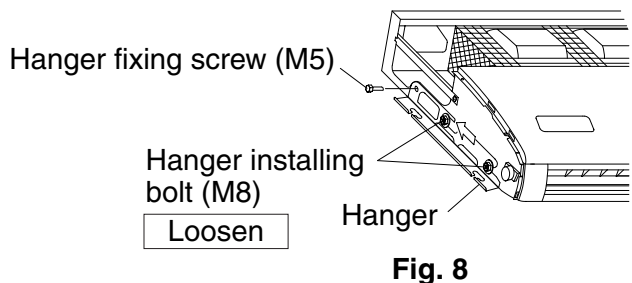
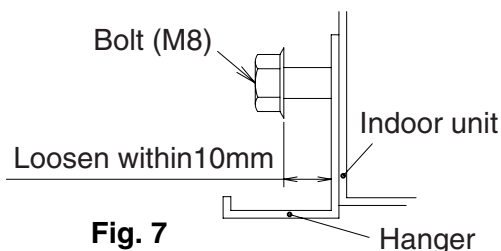

### ⚠ CAUTION

Do not remove the tape (milky white) applied to the outside of the indoor unit. It may cause electric shocks or a fire.



#### (4) Install the hanging bolts.

- Use M8 or M10 bolts for hanging the indoor unit.
  - Adjust the length of the hanging bolt from the ceiling in advance. **(Refer to Fig. 9)**
  - Use hole-in-anchors for the existing bolts and embedded inserts or foundation bolts for new bolts, and fix the unit firmly to the building so that it may withstand the mass of the unit.
- In addition, adjust the distance from the ceiling in advance.

#### CAUTION

If the hanging bolt is too long, it may damage or break the indoor unit or options.

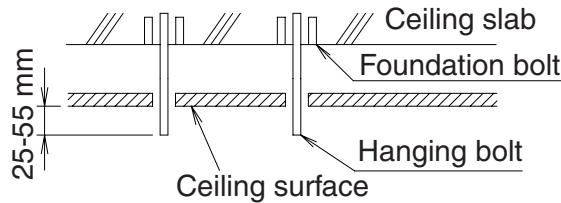

**Fig. 9**

#### NOTE

- Parts shown **Fig. 9** will be all field supply.

## 5. INSTALLATION OF THE INDOOR UNIT

«It is easy to attach the optional parts before installing the indoor unit. Refer to also the installation manual attached to the optional parts.»

For installation, use the attached installation parts and specified parts.

#### (1) Fix the hanger to the hanging bolt. (Refer to Fig. 10)

#### CAUTION

For safety, make sure to use a washer for hanger (3) (accessory) and fix by double nuts firmly.

#### (2) Lift up the indoor unit, slide from the front and put the hanger installing bolt (M8) into the securely for temporary hanging. (Refer to Fig. 11)

#### (3) Tighten the hanger fixing screws (M5) at 2 places, which were removed, as they were before. (Refer to Fig. 11)

It is necessary to prevent misalignment of the indoor unit.

#### (4) Tighten the hanger installing bolts (M8) at 4 places securely. (Refer to Fig. 11)

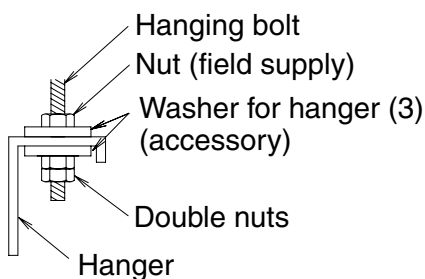

**Fig. 10**

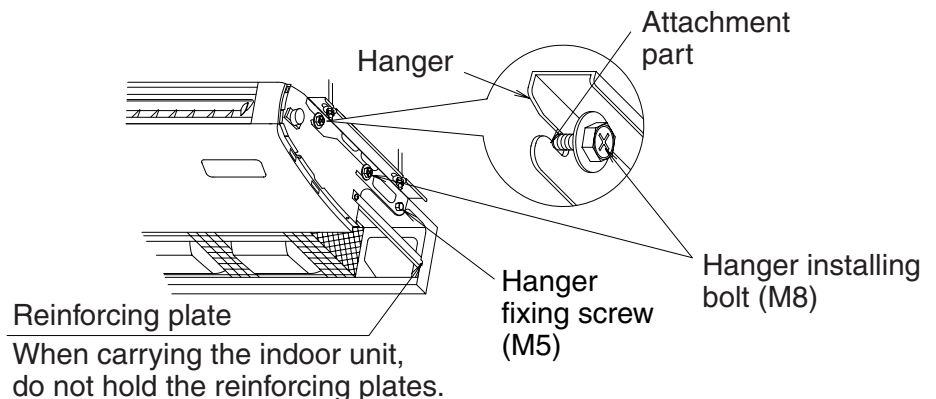

**Fig. 11**

(5) When hanging the indoor unit, make sure to use the level to have better drainage and install it horizontally. Also, if it is possible at the installation site, install so that the drain piping side is slightly lower. (Refer to Fig. 12)

**CAUTION**

- Setting the indoor unit at an angle opposite to the drain piping might cause a water leakage.
- **Do not insert materials other than that specified into the clearance between the hanger and the washer for hanger (3).**

Unless the washers are properly attached, the hanging bolts may come off from the hanger.

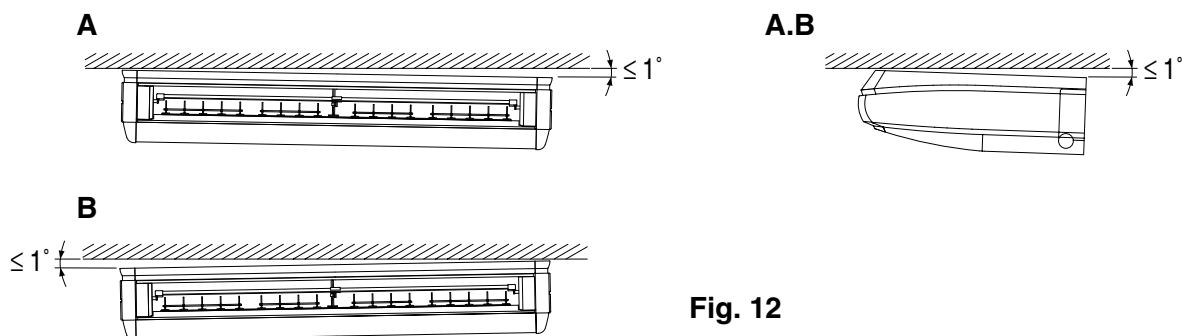

Fig. 12

**A. When the drain piping is tilted to the right, or to the right and back.**

Place it level, or tilt it slightly to the right or the back. (Within 1°)

**B. When the drain piping is tilted to the left, or to the left and back.**

Place it level, or tilt it slightly to the left or the back. (Within 1°)

**WARNING**

**The indoor unit must be securely installed on a place that can withstand the mass.**

If the strength is insufficient, the indoor unit may fall down and cause injuries.

## 6. REFRIGERANT PIPING WORK

- For the outdoor unit refrigerant piping, refer to the installation manual attached to the outdoor unit.
- Carry out insulation of both gas and liquid refrigerant piping securely. If not insulated, it may cause water leakage. For gas piping, use insulation material of which heat resistant temperature is not less than 120°C. For use under high humidity, strengthen the insulation material for refrigerant piping. If not strengthened, the surface of insulation material may sweat.
- Before installation work, make sure that the refrigerant is R410A. (Unless the refrigerant is R410A, the normal operation cannot be expected.)

**CAUTION**

**This air conditioner is a dedicated model for new refrigerant R410A. Make sure to meet the requirements shown below and carry out installation work.**

- **Use dedicated piping cutters and flaring tools for R410A.**
- **When making a flare connection, coat the flared inner surface only with ether oil or ester oil.**
- **Use only the flare nuts attached to the air conditioner. If other flare nuts are used, it may cause refrigerant leakage.**
- **To prevent contamination or moisture from getting into the piping, take measures such as pinching or taping the pipings.**

**Do not mix substance other than the specified refrigerant such as air into the refrigeration circuit. If the refrigerant leaks during the work, ventilate the room.**

- Remove the stay for packing and delivering (reinforcing plate) before refrigerant piping work. (Refer to Fig. 18)
- The refrigerant is pre-charged in the outdoor unit.

- When connecting the pipings to the air conditioner, make sure to use a spanner and a torque wrench as shown in **Fig. 13**.

For the dimension of flared part, refer to the Table 1.

- When making a flare connection, coat the flared inner surface only with ether oil or ester oil. (**Refer to Fig. 14**) Then, turn the flare nut 3 to 4 times with your hand and screw in the nut.

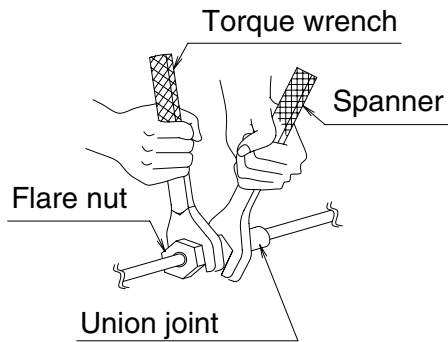

**Fig. 13**

Coat the flared inner surface only with ether oil or ester oil

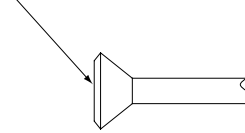

**Fig. 14**

- For the tightening torque, refer to the Table 1.

Table 1

Piping size (mm)	Tightening torque (N·m)	Dimension for processing flare A (mm)	Flare shape
φ 6.4	15.7 ± 1.5	8.9 ± 0.2	<p>The diagram shows a cross-section of a flare. The angle between the two flared surfaces is 90° ± 2°. The angle between the outer edge and the vertical axis is 45° ± 2°. The radius of the outer edge is R0.4-0.8. The width of the flare is labeled 'A'.</p>
φ 9.5	36.3 ± 3.6	13.0 ± 0.2	
φ 12.7	54.9 ± 5.4	16.4 ± 0.2	
φ 15.9	68.6 ± 6.8	19.5 ± 0.2	

**CAUTION**

**Do not have oil adhere to the screw fixing part of resin parts.**

If oil adheres, it may weaken the strength of screwed part.

**Do not tighten flare nuts too tight.**

If a flare nut cracks, the refrigerant may leak.

- If there is no torque wrench, use Table 2 as a rule of thumb. When tightening a flare nut with a spanner harder and harder, there is a point where the tightening torque suddenly increases. From that position, tighten the nut additionally the angle shown in Table 2. After the work is finished, check securely that there is no gas leak. If the nut is not tightened as instructed, it may cause slow refrigerant leak and result in malfunction (such as does not cool or heat).

Table 2

Piping size (mm)	Tightening angle	Recommended arm length of tool used
φ 6.4	60° – 90°	Approximately 150mm
φ 9.5	60° – 90°	Approximately 200mm
φ 12.7	30° – 60°	Approximately 250mm
φ 15.9	30° – 60°	Approximately 300mm

**CAUTION**

**Insulation of field piping must be carried out up to the connection inside the casing.**

If the piping is exposed to the atmosphere, it may cause sweating, burn due to touching the piping, electric shocks or a fire due to the wiring touching the piping.

- After leak test, referring to **Fig. 15**, insulate both the gas and liquid piping connection with the attached joint insulating material (6) and (7) to prevent the pipings from getting exposed. Then, tighten the both ends of insulating material with the clamp (4).
- Wrap the sealing material (Small) (9) around the joint insulating material (6) (flare nut section), only the gas piping side.
- Make sure to bring the seam of joint insulating material (6) and (7) to the top.

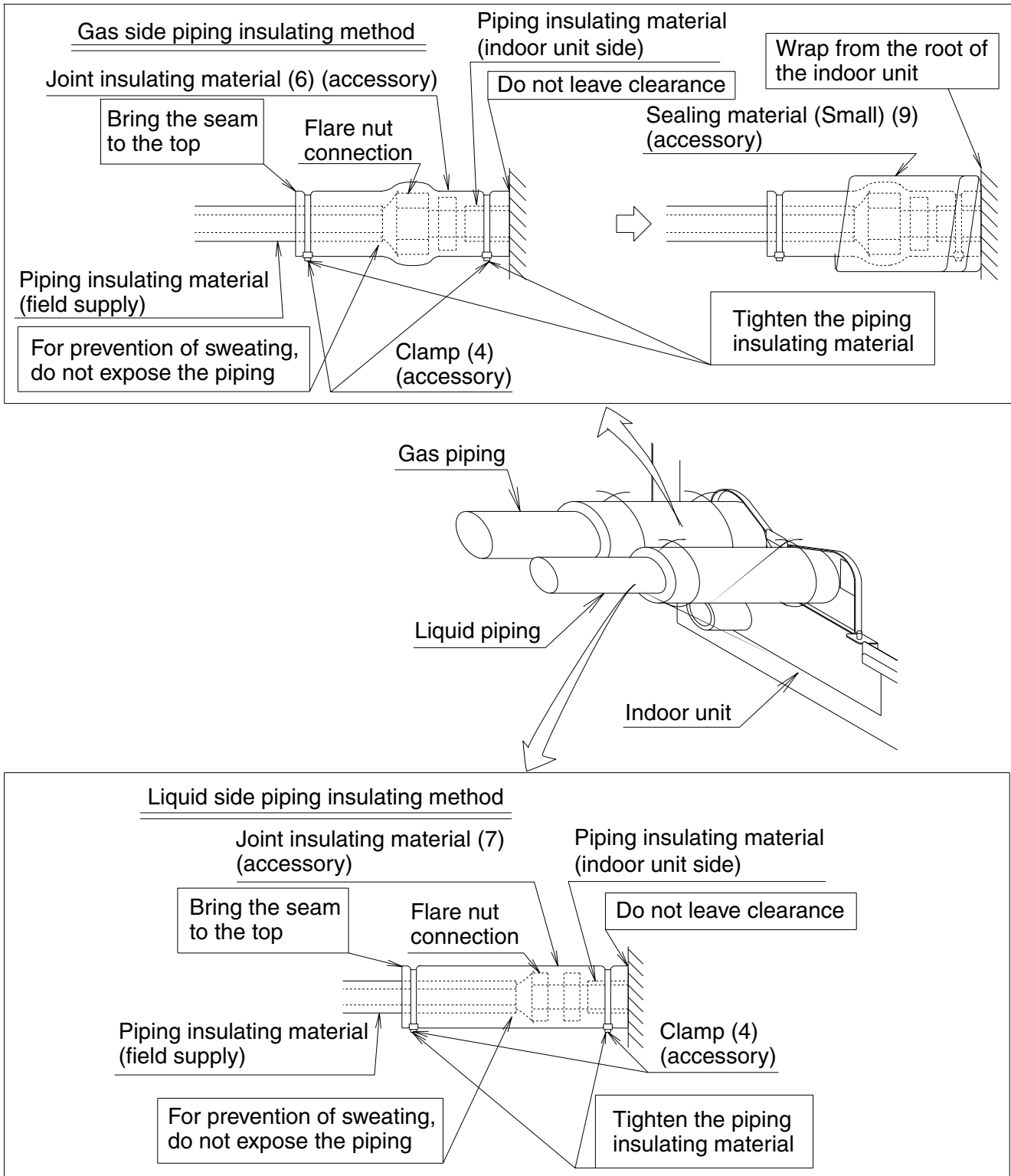

**Fig. 15**

**(1) For rear side piping**

- Remove the rear piping penetration cover, and connect the piping. **(Refer to Fig. 16 and 18)**

**(2) For upward piping**

- For upward piping, L-shaped connection piping kit (optional accessory) will be required.
- Remove the top panel penetration cover, and use the L-shaped connection piping kit (optional accessory) to conduct piping. **(Refer to Fig. 16 and 17)**

**(3) For right side surface piping**

- Remove the stay for packing and delivering (reinforcing plate) at the right side, and put back the screw to the original position of the indoor unit. **(Refer to Fig. 18)**
- Open the knockout hole at the decoration side panel (right), and connect piping. **(Refer to Fig. 18)**

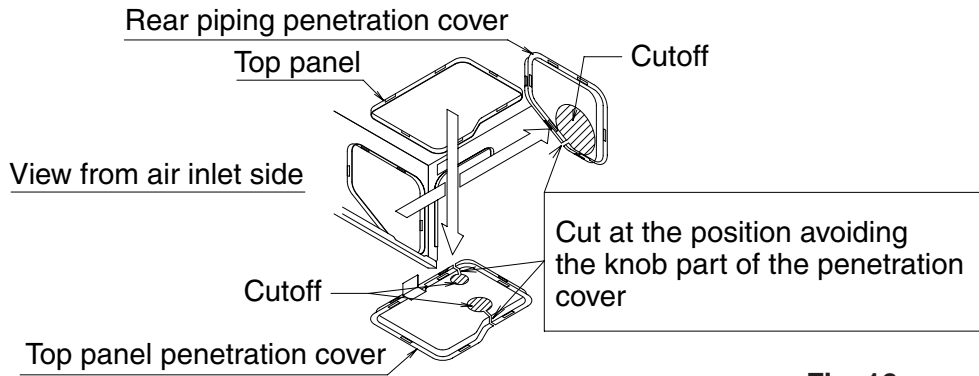

**Fig. 16**

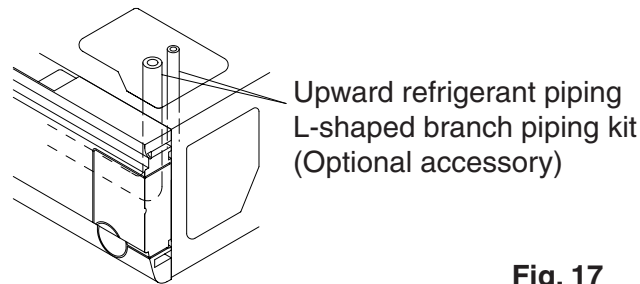

**Fig. 17**

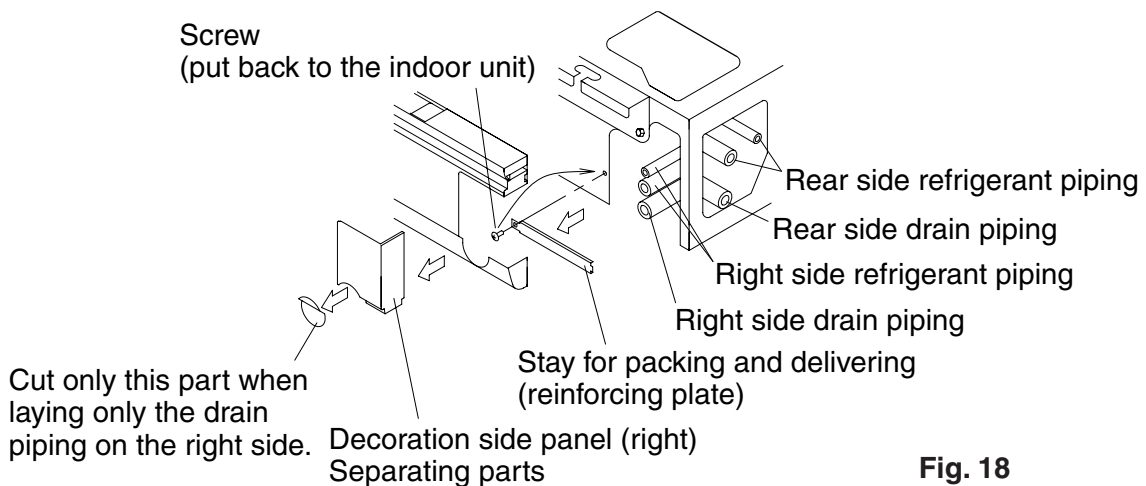

**Fig. 18**

- After piping is finished, cut the removed penetration cover along the shape of piping, and install. Also, for top panel penetration cover, as it was before removed, put the horizontal blade motor and thermostat lead through the clamp of the top panel penetration cover and fix. **(Refer to Fig. 16 and 19)** When doing this, block any gaps between the piping penetration cover and the piping using putty to prevent dust from entering the indoor unit.

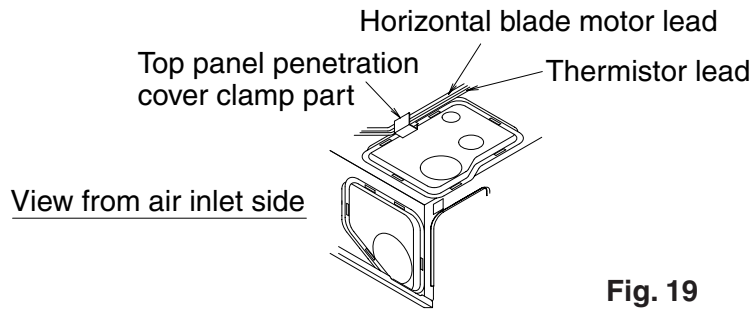

Fig. 19

- Before brazing refrigerant piping, have nitrogen flow through the refrigerant piping and substitute air with nitrogen. Then, carry out brazing (NOTE 2). (Refer to Fig. 20) After all the brazing works are finished, carry out flare connection with the indoor unit.

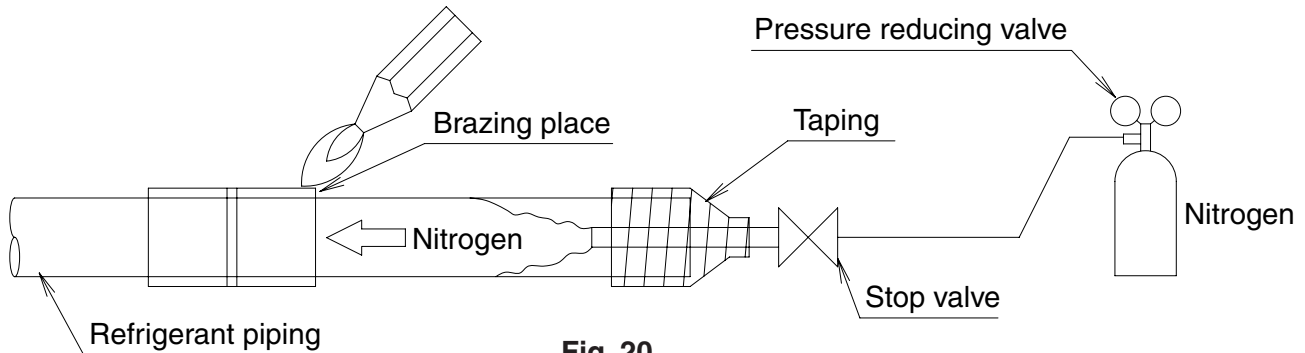

Fig. 20

**NOTE**

1. The proper pressure for having nitrogen flow through the piping is approximately 0.02MPa, a pressure that makes one feel like breeze and can be obtained through a pressure reducing valve.
2. Do not use flux when brazing refrigerant piping. Use phosphor copper brazing filler metal (BCuP-2: JIS Z 3264/B-Cu93P-710/795: ISO 3677) that does not require flux. (If chlorinated flux is used, the piping will be corroded and, in addition if fluorine is contained, the refrigerant oil will be deteriorated and the refrigerant circuit will be affected badly.)
3. When carrying out leakage test of refrigerant piping and the indoor unit after the installation of indoor unit is finished, confirm the connecting outdoor unit installation manual for test pressure. Refer to also the outdoor unit installation manual or technical document for refrigerant piping.
4. In case of refrigerant shortage due to forgetting additional refrigerant charge etc., it will result in malfunction such as does not cool or does not heat. Refer to the outdoor unit installation manual or technical document for refrigerant piping.



**CAUTION**

**Do not use antioxidant when brazing piping.**

It may result in malfunction of components and clogging of piping due to residue.

## 7. DRAIN PIPING WORK

### (1) Carry out drain piping.

- Carry out drain piping so that drainage can be ensured.
- Drain piping can be connected from the following directions: For right rear/right side, refer to **Fig. 18** of “6. REFRIGERANT PIPING WORK”, and for left rear/left side, refer to **Fig. 21**.
- When conducting left rear/left side drain piping, remove the protection net. Then, remove the drain socket cap and insulation material applied to left side drain socket and apply them to the right side drain socket. When doing this, insert the drain socket cap all the way in to prevent a water leakage. After the drain hose (1) (accessory) is installed, attach the protection net by reversing the steps taken to remove it. **(Refer to Fig. 22)**
- Select the piping diameter equal to or larger than that of the drain hose (1) (accessory) (polyvinyl chloride piping, nominal diameter 20mm, outside diameter 26mm).
- Install the drain piping as short as possible with downward inclination of 1/100 or more and without where air may stagnate. **(Refer to Fig. 23 and 24)**  
(It may cause abnormal sound such as bubbling noise)

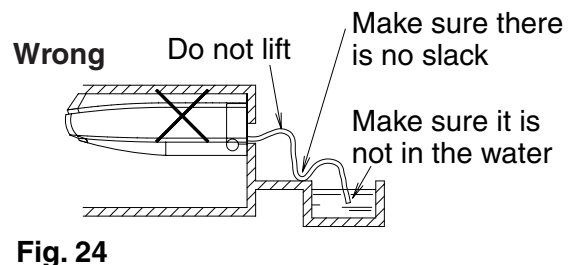
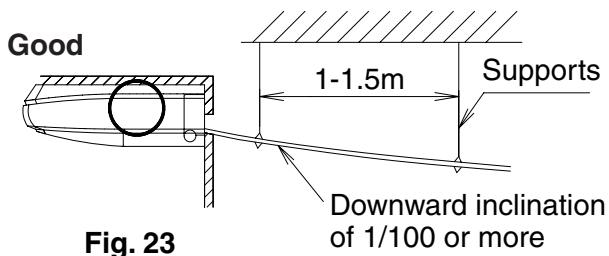
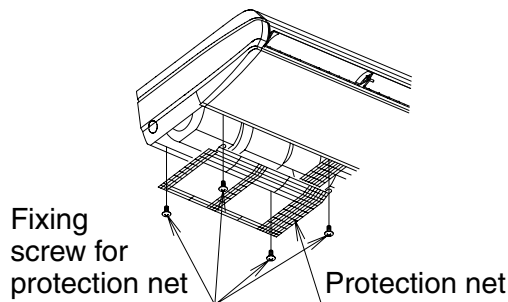
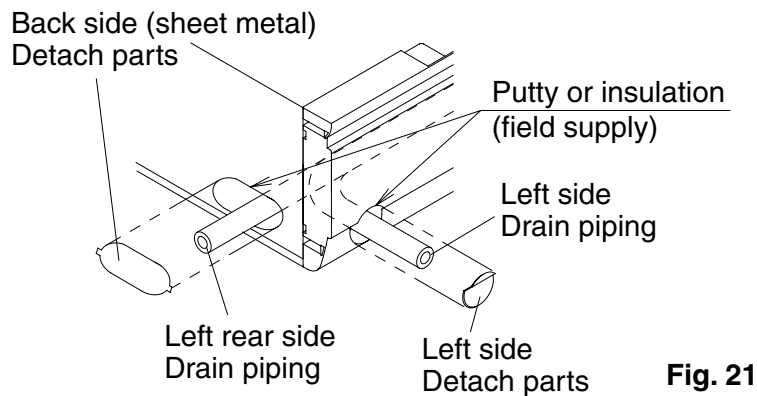

### ⚠ CAUTION

If drain stagnates in the drain piping, the piping may be clogged.

- Make sure to use the attached drain hose (1) and metal clamp (2). Also, insert the drain hose (1) into the root of the drain socket, and tighten the metal clamp (2) at the root of the drain socket tightly. **(Refer to Fig. 25 and 26)**  
(Install the metal clamp (2) so that the tightening part is in the range of about 45° as shown in the Fig. 26.)  
(Do not bond the drain socket and drain hose. If so, maintenance and inspection for the heat exchanger and others cannot be conducted.)

**⚠ CAUTION**

If an old drain hose or an elbow or a clamp is used, it may cause water leakage.

- Bend the tip of the metal clamp (2) so that the sealing material does not bulge. **(Refer to Fig. 26)**
- When performing insulation, wind the sealing material (Large) (8) attached starting from the base of the metal clamp (2) and drain hose (1) in the direction of the arrow. **(Refer to Fig. 25 and 26)**

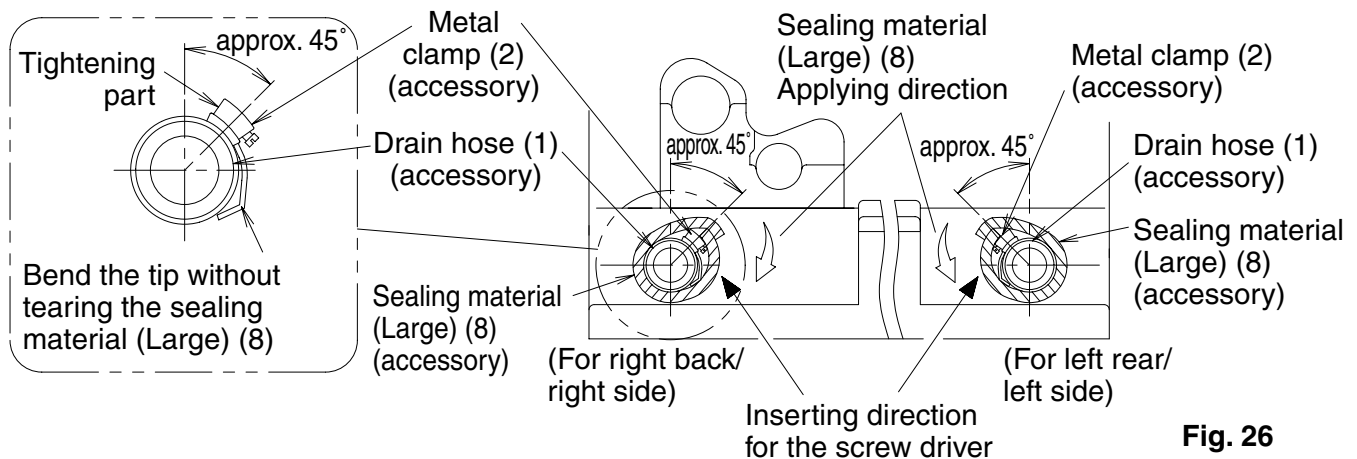
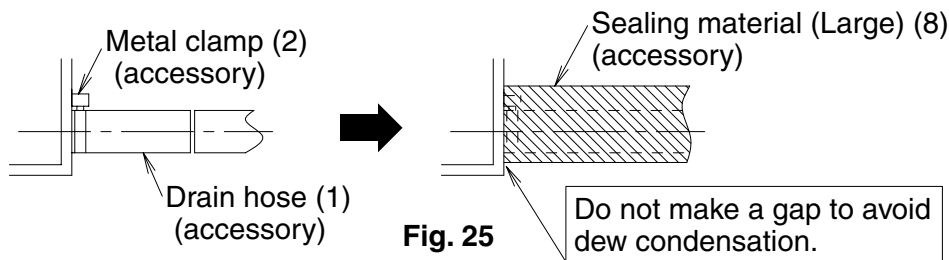

- Be sure to insulate all drain piping running indoors.
- Do not deflect the drain hose (1) inside of the indoor unit. **(Refer to Fig. 27)**  
(It may cause abnormal noise such as bubbling noise.)  
(If the drain hose (1) is deflected, it may damage the suction grille.)

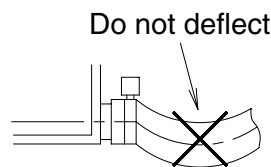

**Fig. 27**

- Install supports at a distance of 1 to 1.5m so that the piping may not deflect. **(Refer to Fig. 23)**

**⚠ CAUTION**

To prevent dust from entering the indoor unit, cover the gap with the drain piping by putty or insulation (field supply) so that no clearance is made.

However, when putting piping and remote controller wiring through the same hole, cover the gap between the through cover and the piping after **8. ELECTRIC WIRING WORK** is completed.



< CAUTION >

- To avoid the attached drain hose (1) getting excessive force, do not bend nor twist it. (It may cause water leakage.)
- When conducting the centralized drain piping, follow the instructions in **Fig. 28**. For the diameter of the centralized drain piping, select the diameter matching the capacity of the indoor unit to be connected. (Refer to the technical document)

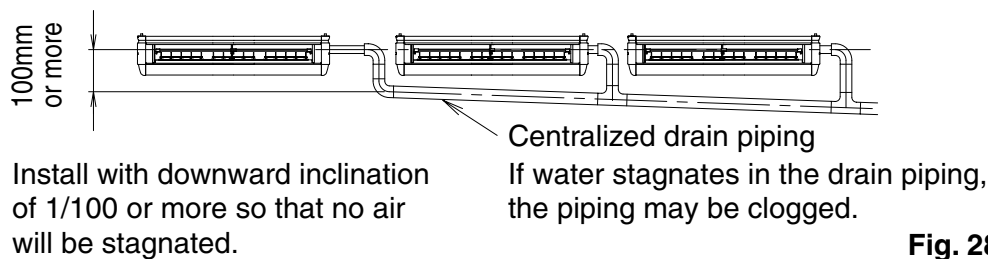
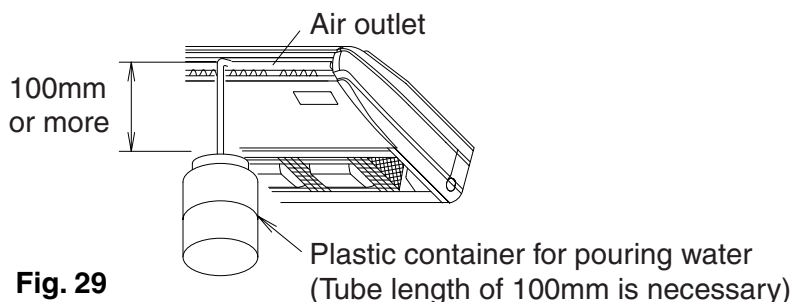

**Fig. 28**

- Connecting drain piping.  
Do not connect the drain piping directly to the sewage that gives off ammonia odor. The ammonia in the sewage may go through the drain piping and corrode the heat exchanger of the indoor unit.
- When installing the drain pump kit (optional accessory), also refer to the installation manual included to the drain pump kit.

**(2) After piping is finished, check if the drain flows smoothly.**

- Gradually put about 0.6 liter of water for drain confirmation into the drain pan from the air outlet. (Refer to Fig. 29)



**Fig. 29**

- After the drain piping work, install the stay for packing and delivering (reinforcing plate), which was removed in the section of “6. REFRIGERANT PIPING WORK”. However, it is not necessary to install the stay for packing and delivering at the right side (reinforcing plate). (Refer to Fig. 30)

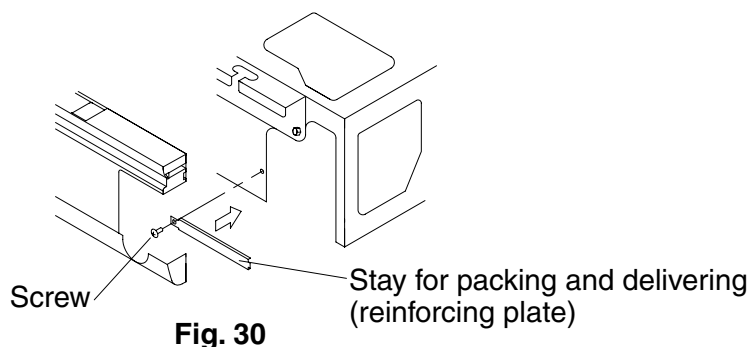

**Fig. 30**

## 8. ELECTRIC WIRING WORK

### 8-1 GENERAL INSTRUCTIONS

- Make certain that all electric wiring work is carried out by qualified personnel according to the applicable legislation and this installation manual, using a separate circuit. Insufficient capacity of the power supply circuit or improper electrical construction may lead to electric shocks or a fire.
- Make sure to install an earth leakage breaker. Failure to do so may cause electrical shocks and a fire.
- For electric wiring work, refer to also the “WIRING DIAGRAM” attached to the control box lid.
- Carry out wiring between the outdoor units, indoor units and the remote controllers according to the wiring diagram. Carry out installation and wiring of the remote controller according to the “installation manual” attached to the remote controller.
- Multiple number of indoor units are connected to one outdoor unit. Name each indoor unit as A-unit, B-unit ..... and the like. When these indoor units are wired to the outdoor unit and the BS unit, always wiring the indoor unit to the terminal indicated with the same symbol on the terminal block. If the wiring and the piping are connected to the different indoor units and operated, it will result in malfunction.
- Make sure to earth the air conditioner.  
Earthing resistance should be according to applicable legislation.
- Do not connect the earth wiring to gas or water piping, lightning conductor or telephone earth wiring.
  - Gas piping ..... Ignition or explosion may occur if the gas leaks.
  - Water piping .... Hard vinyl tubes are not effective earths.
  - Lightning conductor or telephone earth wiring ... Electric potential may rise abnormally if struck by a lightning bolt.
- Do not turn on the power supply (branch switch, branch overcurrent breaker) until all the works are finished.
- Carry out installation and wiring of the remote controller according to the “installation manual” attached to the remote controller.
- Do not touch the Printed Circuit Board assembly. It may cause malfunction.

### 8-2 ELECTRICAL CHARACTERISTICS

Indoor unit				Power supply		Fan motor	
Model	Hz	Volts	Voltage range	MCA	MFA	kW	FLA
FXHQ32AVEB	50	220-240	Max. 264 Min. 198	0.8	16	0.060	0.6
FXHQ63AVEB				0.8	16	0.091	0.6
FXHQ100AVEB				1.6	16	0.150	1.3

MCA: Min. Circuit Amps (A) ;                      MFA: Max. Fuse Amps (A)  
 kW: Fan Motor Rated Output (kW) ;              FLA: Full Load Amps (A)

### 8-3 SPECIFICATION FOR FIELD SUPPLY FUSES AND WIRING

Model	Power supply wiring			Remote controller wiring Transmission wiring	
	Field fuses 	Wiring	Size	Wiring	Size
FXHQ32AVEB	16A	H05VV-U3G NOTE 1)	Wire size and length must comply with local codes.	Vinyl cord with sheath or cable (2 core) NOTE 2)	0.75-1.25mm <sup>2</sup>
FXHQ63AVEB					
FXHQ100AVEB					

The maximum allowable lengths of remote controller wiring and transmission wirings are as follows:

- (1) Remote controller wiring (indoor unit - remote controller).....Max.500m
- (2) Transmission wirings.....Total wiring length 2000m
  - Outdoor unit - Indoor unit ..... Max.1000m
  - Outdoor unit - BS unit ..... Max.1000m
  - BS unit - Indoor unit ..... Max.1000m
  - Indoor unit - Indoor unit..... Max.1000m

#### NOTE

1. Shows only in case of protected piping. Use H07RN-F in case of no protection.
2. Vinyl cord with sheath or cable (Insulated thickness : 1mm or more)

## 8-4 WIRING CONNECTION METHOD

### <<Caution for wiring>>

- The indoor units in the same system can be connected to the power supply from one branch switch. However, selection of branch switch, branch over current circuit breaker and wiring size must be according to applicable legislation.
- For connection to the terminal block, use ring type crimp style terminals with insulation sleeve or treat the wiring with insulation.

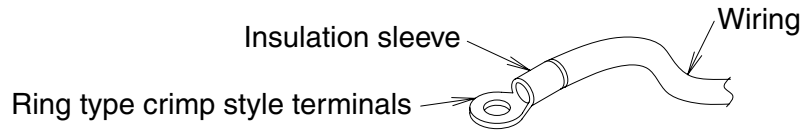

- If the above is not available, make sure to observe the following items.
- 2 wirings of different sizes to the terminal block for power supply is prohibited.

Connection of 2 wirings of same size must be carried out on both sides.

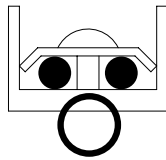

Connection of 2 wirings on one side is prohibited.

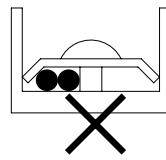

Connection of wirings of different sizes is prohibited.

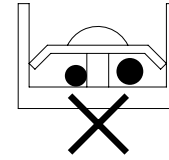

(Abnormal heating may occur if the wirings are not tightened securely.)

- Use the required wirings, connect them securely and fix these wirings so that external force may not apply to the terminals.
- Use a proper screw driver for tightening the terminal screws. If an improper screw driver is used, it may damage the screw head and a proper tightening cannot be carried out.
- If a terminal is over tightened, it may be damaged. Refer to the table shown below for tightening torque of terminals.

	Tightening torque (N·m)
Terminal block for remote controller and transmission wirings	0.88±0.08
Terminal block for power supply	1.47±0.14
Earth terminal	1.69±0.25

- Conduct wiring so that the earth lead comes out from the notched part of the cup washer. (Otherwise, earth lead contact will be insufficient and grounding effect may be lost.)
- Do not carry out soldering finish when stranded wirings are used.

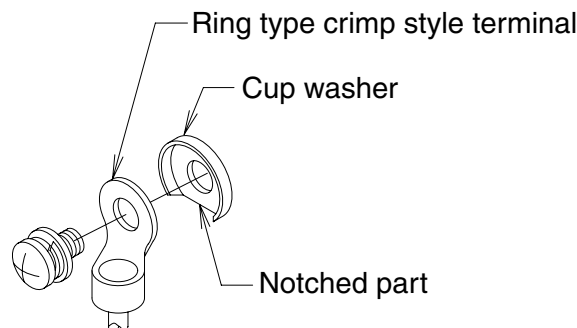

**<Power supply wiring • earth wiring • remote controller wiring • transmission wiring connecting method>**

- (1) Hold the control box, loosen the fixing screws (2 pieces) and remove the control box lid **(Refer to Fig. 31)**.
- (2) Open the knockout hole and put the resin bushing (10) (accessory) on the rear or top side (sheet metal).
- (3) Pull the power supply wiring through the penetration hole and connect to the terminal block for power supply (X2M; dipoles) **(Refer to Fig. 31)**. Connect the earth wiring to the earth terminal. Next, tie into a bundle and fix by the attached the wiring fixture (11) and clamp (4) so that no tension will be given to the wiring. **(Refer to Fig. 32)**
- (4) Pull the remote controller wiring and transmission wiring through the penetration hole, and connect the remote controller wiring to [P1·P2] and transmission wiring to [F1·F2] (no polarity) **(Refer to Fig. 32)**. Next, tie into a bundle and fix by the included the wiring fixture (11) and clamp (4) so that no tension will be given to the wiring transmission part. **(Refer to Fig. 32)**

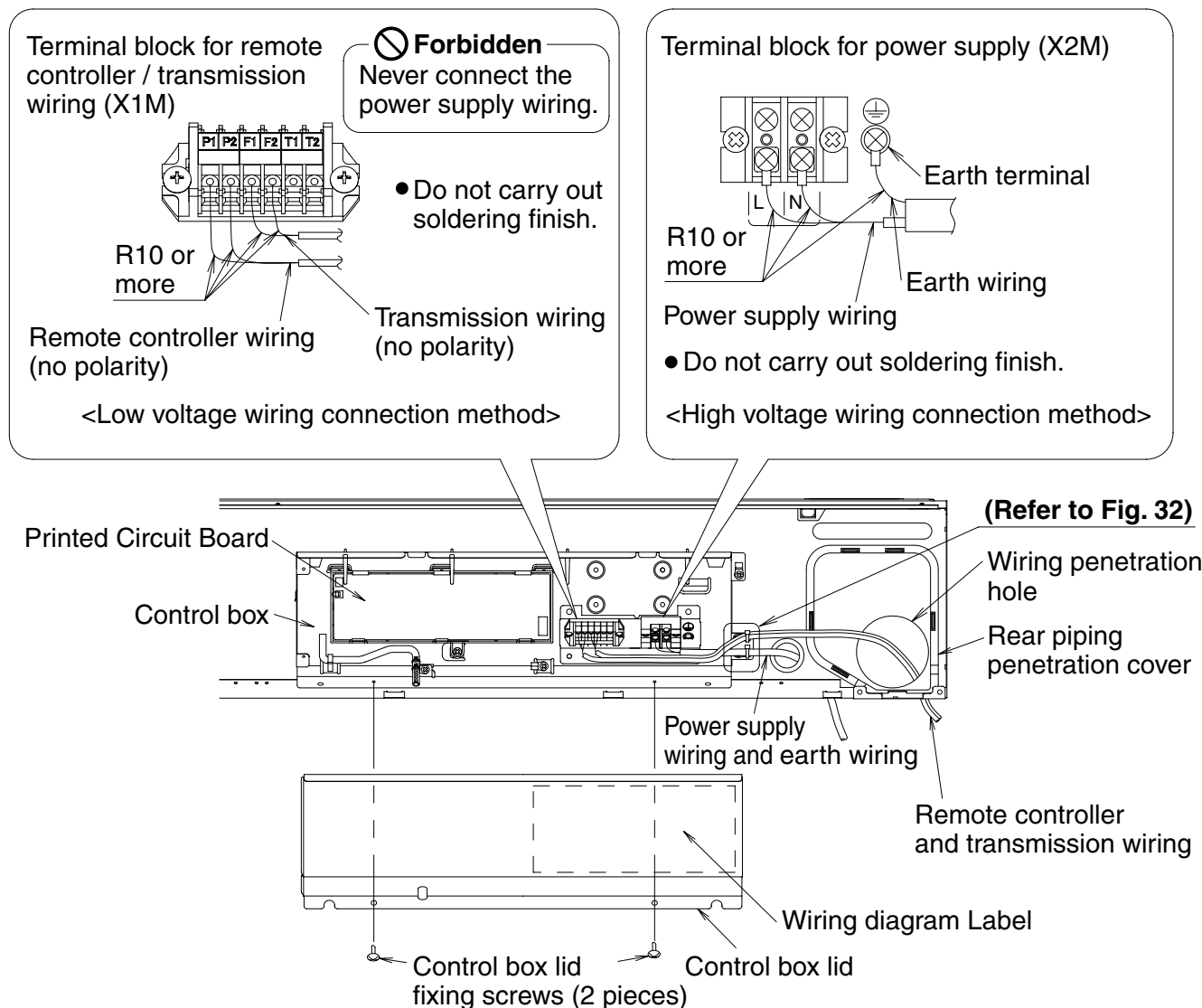

**Fig. 31**

**⚠ WARNING**

- When wiring, form the wirings orderly so that the control box lid can be securely fastened. If the control box lid is not in place, the wirings may float up or be sandwiched by the box and the lid and cause electric shocks or a fire.

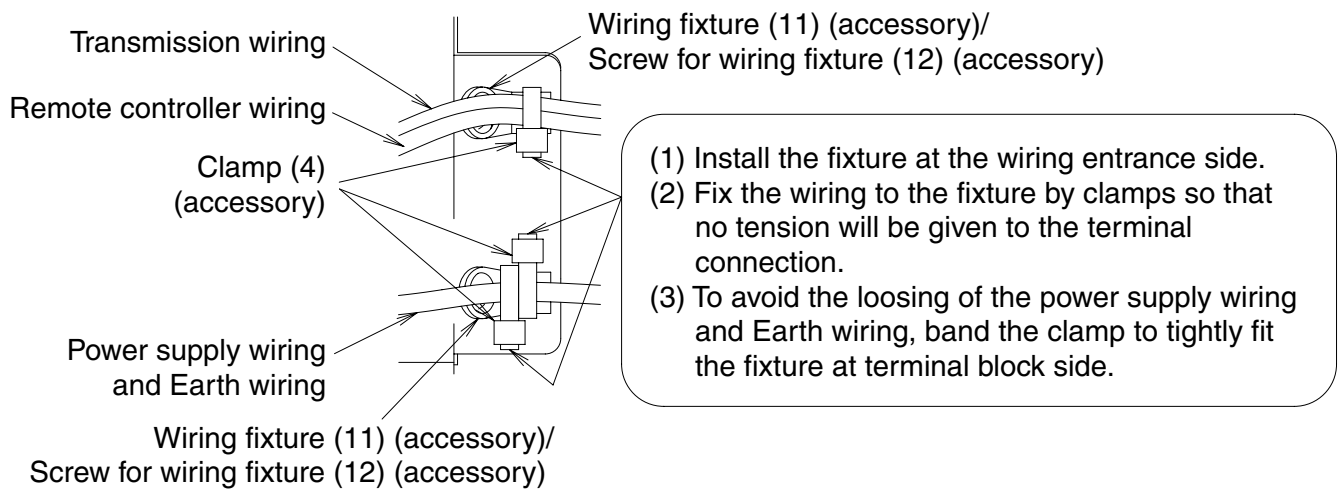
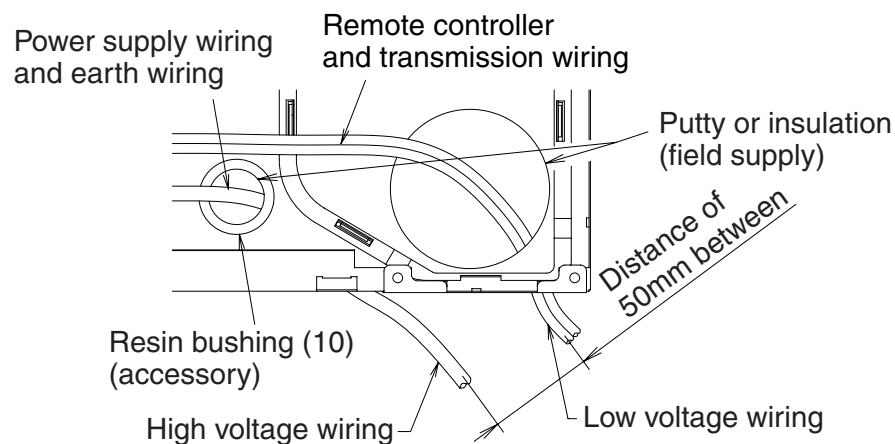

**Fig. 32**

**CAUTION**

- When conducting wiring work, do not touch the printed circuit board. It may cause failure.
- Never connect the power supply wiring to the terminal block for remote controller/transmission wiring. It may damage the total system.
- Do not connect the remote controller/transmission wiring to the wrong terminal block.

- In case the piping penetration cover is cut off and used as wiring penetration hole, after the wiring connection is finished, mend the cover.
- Seal the clearance around the wirings with putty and insulating material (field supply).  
(If insects and small animals get into the indoor unit, short circuiting may occur inside the control box.)
- If the low voltage wiring (remote controller wiring) and the high voltage wiring (power supply wiring, earth wiring) are brought into the indoor unit from the same place, they may be affected by electric noise (outside noise) and cause malfunction or failure.
- Keep the distance of 50mm or more between the low voltage wiring (remote controller wiring) and the high voltage wiring (power supply wiring, earth wiring) at anywhere outside the indoor unit. If both the wirings are laid down together, they may be affected by electric noise (outside noise) and cause malfunction or failure.



## 8-5 EXAMPLE OF WIRING

<< No. 1 system: When 1 remote controller is used for 1 indoor unit. >>

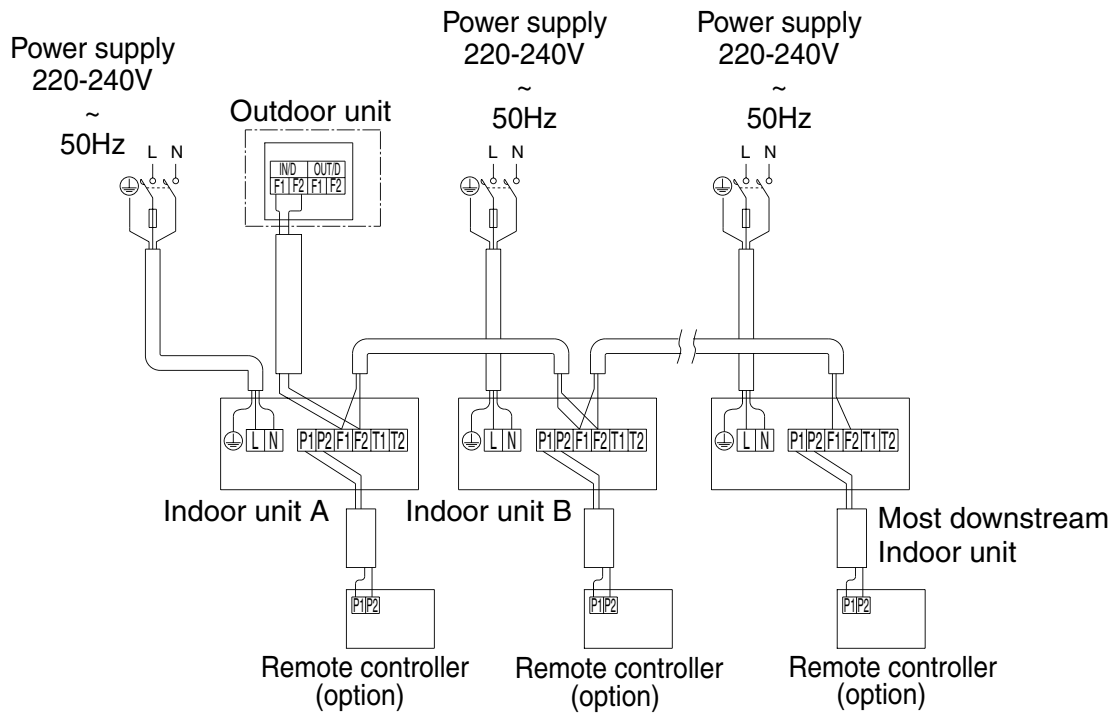

<< No. 2 system: When carrying out group control or 2 remote controller control. >>

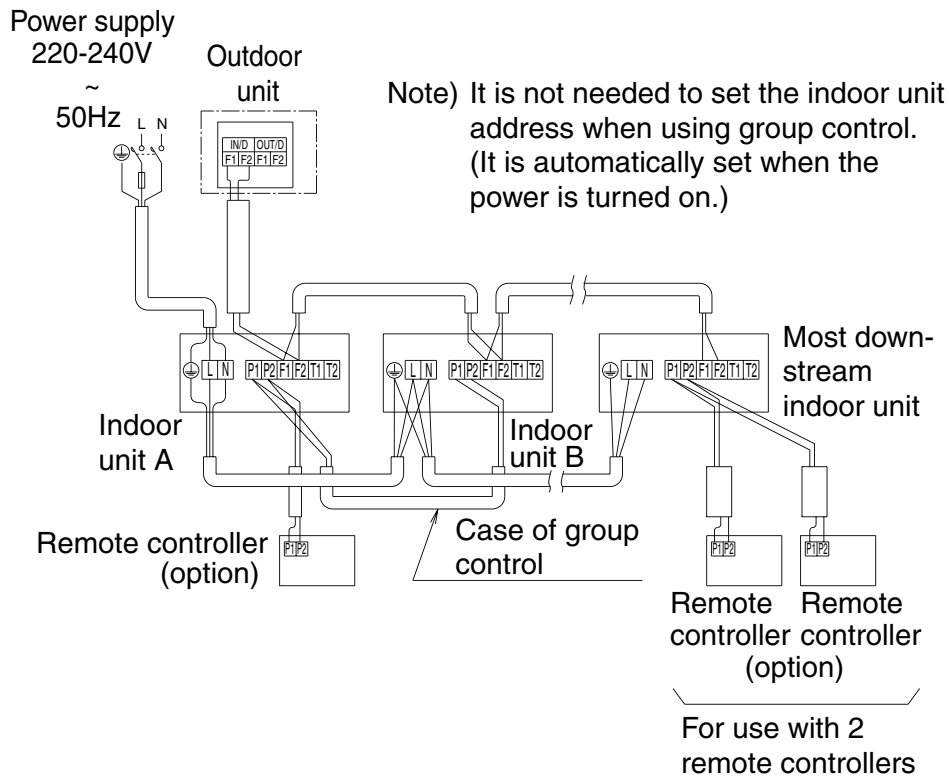

<< No. 3 system: When BS unit is used >>

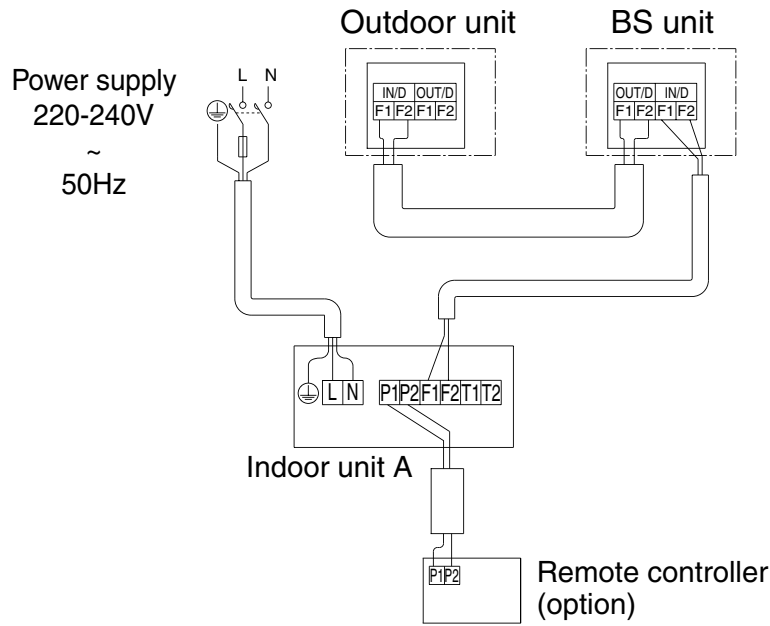

**⚠ WARNING**

Be sure to install an earth leakage breaker.  
Failure to do so may cause electric shocks and a fire.

**8-6 FOR CONTROL WITH 2 REMOTE CONTROLLERS (TO CONTROL 1 INDOOR UNIT WITH 2 REMOTE CONTROLLERS)**

- For control with 2 remote controllers, set one remote controller as Main and the other remote controller as Sub.

**<Changeover method from Main to Sub and vice versa>**

Refer to the installation manual attached to the remote controller.

**<Wiring method>**

- (1) Remove the control box lid according to the wiring connection method.
- (2) Carry out additional wiring from the remote controller 2 (Sub) to the terminals (P<sub>1</sub>, P<sub>2</sub>) for remote controller wiring on the terminal block (X1M) in the control box.

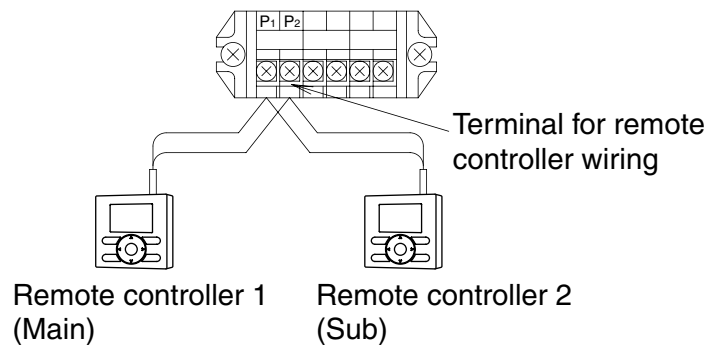

**Fig. 33**

**< CAUTION >**

When using the group control and the 2 remote controllers control at the same time, connect the remote controller 2 (Sub) to the indoor unit at the end of the crossover wiring (the largest No.). **(Refer to Fig. 34)**

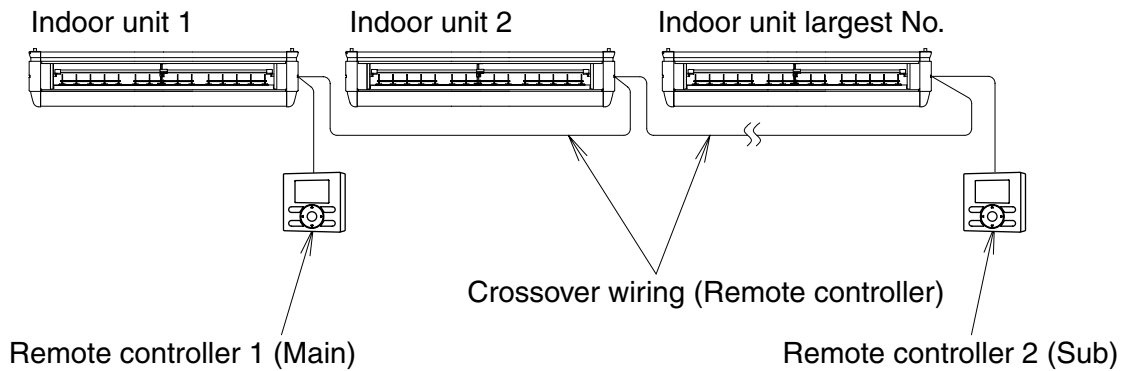

**Fig. 34**

### 8-7 FOR CENTRALIZED CONTROL

- When centralized equipment (such as centralized controller) is used for control, it is required to set the group No. on the remote controller.  
For details, refer to the manuals attached to the centralized equipment.
- Connect the centralized equipment to the indoor unit connected to the remote controller.

### 8-8 FOR REMOTE CONTROL (FORCED OFF OR ON/OFF OPERATION)

#### (1) Wiring method and specification

- Remote control is available by transmission the external input to the terminals T1 and T2 on the terminal block for remote controller and transmission wiring.

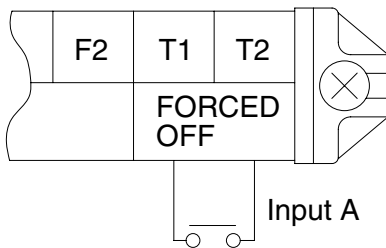

Wiring specification	Sheathed vinyl cord or 2 core cable
Wiring size	0.75-1.25mm <sup>2</sup>
Wiring length	Max. 100m
External contact spec	Contact that can make and break the min. load of DC15V · 1mA

#### (2) Actuation

- Input A of FORCED OFF and ON/OFF OPERATION will be as the table shown below.

In case of FORCED OFF	FORCED OFF by input A of "ON" (Remote controller prohibited)	Remote controller permitted by input A of "OFF"
In case of ON/OFF OPERATION	Operation by input A of "OFF" → "ON"	Stop by input A of "ON" → "OFF"

#### (3) How to choose FORCED OFF or ON/OFF OPERATION

- For choosing FORCED OFF or ON/OFF OPERATION, setting by remote controller is required.  
(Refer to **10. FIELD SETTING AND TEST OPERATION**)



## 9. MOUNTING SUCTION GRILLE · DECORATION SIDE PANEL

Install securely in the reverse order when decoration side panel and suction grille were removed.

- When installing the suction grille, hang the string of the suction grille to the hanging part of the indoor unit shown **Fig. 35**.

### ⚠ CAUTION

When closing the suction grille, the strap may get caught. Confirm that the strap does not stick out of the side of the suction grille before closing.

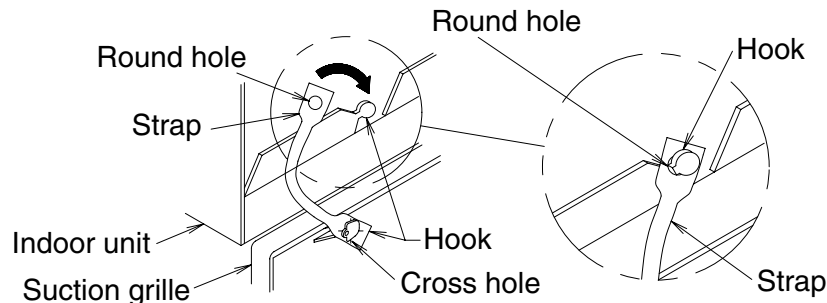

Fig. 35

## 10. FIELD SETTING AND TEST OPERATION

<<Refer to also the installation manual attached to the outdoor unit.>>

### ⚠ CAUTION

Before carrying out field setting, check the items mentioned in the clause 2 “1. Items to be checked after the installation work is completed” on page 4.

- Check if all the installation and piping works for the air conditioner are completed.
- Check if the control box lids of the air conditioner are closed.

### <FIELD SETTING>

<After turn on the power supply, carry out field setting from the remote controller according to the installation state.>

- Carry out setting at 3 places, “Mode No.”, “FIRST CODE No.” and “SECOND CODE No.”.  
The settings shown by “” in the table indicate those when shipped from the factory.
- The method of setting procedure and operation is shown in the installation manual attached to the remote controller.  
(Note) Though setting of “Mode No.” is carried out as a group, if you intend to carry out individual setting by each indoor unit or confirmation after setting, carry out setting with the “Mode No.” shown in the parenthesis ( ).
- In case of remote control, for changeover of input to FORCED OFF or to ON/OFF OPERATION.  
[1] Enter into the field setting mode with the remote controller.  
[2] Select Mode No. “12”.  
[3] Set the FIRST CODE No. to “1”.  
[4-1] For FORCE OFF, set the SECOND CODE No. to “01”.  
[4-2] For ON/OFF OPERATION, set the SECOND CODE No. to “02”.  
(It is set to FORCED OFF when shipped from the factory.)
- Ask your customer to keep the manual attached to the remote controller together with the operation manual.
- Do not carry out setting other than those shown in the table.

## 10-1 SETTING OF CEILING HEIGHT

- Set the SECOND CODE No. according to the ceiling height as shown in the Table 3.  
(The SECOND CODE No. is set at "01", when shipping from the factory.)

Table 3

	Ceiling height (m)			Mode No.	FIRST CODE No.	SECOND CODE No.
	Type 32	Type 63	Type 100			
Standard	2.7 or less	2.7 or less	3.8 or less	13 (23)	0	01
High ceiling	2.7-3.5	2.7-3.5	3.8-4.3			02

### NOTE

Do not set the SECOND CODE No. "03".

## 10-2 SETTING WHEN AN OPTIONAL ACCESSORY IS ATTACHED

- For setting when attaching an optional accessory, refer to the installation manual attached to the optional accessory.

## 10-3 WHEN USING WIRELESS REMOTE CONTROLLER

- When using a wireless remote controller, it is necessary to set the wireless remote controller address. Refer to the installation manual attached to the wireless remote controller.

## 10-4 SETTING FAN SPEED DURING THERMOSTAT OFF

- Set the fan speed according to the using environment after consultation with your customer.  
(When shipping, the SECOND CODE No. "02" is set for the fan speed during the cooler thermostat OFF, and other are set at "01".)

Table 4

Setting		Mode No.	FIRST CODE No.	SECOND CODE No.
Fan operates/stops during thermo OFF (Cooling · heating)	Operates	11 (21)	2	01
	Stops			02
Fan speed during cooling thermostat OFF	LL (Extra low)	12 (22)	6	01
	Setting			02
Fan speed during heating thermostat OFF	LL (Extra low)	12 (22)	3	01
	Setting			02

## 10-5 SETTING FILTER SIGN

- A message to inform the air filter cleaning time will be indicated on the remote controller.
- Set the SECOND CODE No. to the number shown in the Table 5 according to the amount of dust or pollution in the room.
- Though the indoor unit is equipped with the long life filter, it is necessary to periodically clean the filter to avoid clogging of the filter. Please also explain the set time to the customer.
- The periodical filter cleaning time can be shortened depending on the environment.

Table 5

Contamination	Filter hours (long life type)	Mode No.	FIRST CODE No.	SECOND CODE No.	
Normal	Approx. 2500 hrs	10 (20)	0	01	
More contaminated	Approx. 1250 hrs			02	
With indication			3	3	01
No indication*					02

\* Use "No indication" setting when cleaning indication is not necessary such as the case of periodical cleaning being carried out.

**<Test operation>**

- After cleaning the indoor unit inside and the suction grille, carry out test run according to installation manual attached to the outdoor unit.
- When the remote controller operation lamp flashes, it shows that something is abnormal. Check the malfunction codes on the remote controller. The relation between the malfunction codes and abnormal details is described in the operation manual attached to the outdoor unit. Particularly, if the indication is one of those shown in the Table 6, it may be an error in the electrical wiring or the power supply is disconnected. Therefore, recheck Table 6.

Table 6

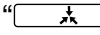
Remote controller indication	Details
Though the centralized control is not carried out, the lamp "  " turns on.	<ul style="list-style-type: none"> <li>• The terminals (T1 · T2) for FORCED OFF on the indoor unit transmission terminal block is short circuited.</li> </ul>
"U4" turns on "UH" turns on	<ul style="list-style-type: none"> <li>• The power supply to the outdoor unit is not made.</li> <li>• The power supply work to the outdoor unit is not carried out.</li> <li>• The transmission wiring and the remote controller wiring and FORCED OFF wiring are connected wrongly.</li> <li>• The transmission wiring is disconnected.</li> </ul>
No indication	<ul style="list-style-type: none"> <li>• The power supply to the indoor unit is not made.</li> <li>• The power supply work to the indoor unit is not carried out.</li> <li>• The remote controller wiring and the transmission wiring and FORCED OFF wiring are connected wrongly.</li> <li>• The remote controller wiring is disconnected.</li> </ul>

**⚠ CAUTION**

After test operation is completed, check the items mentioned in the clause 2 "2. Items to be checked at delivery" on page 4.

If the interior finish work is not completed when the test operation is finished, for protection of the system, ask the customer not operate the indoor unit until the interior finish work is completed.

If the system is operated, the inside of the indoor units may be polluted by substances generated from the coating and adhesives used for the interior finish work and cause water splash and leakage.

**⚠ To the operator carrying out test operation**

After test operation is completed, before delivering the air conditioner to the customer, confirm that the control box lid, the air filter and suction panel are attached.

In addition, explain the power supply status (power supply ON/OFF) to the customer.

**11. WIRING DIAGRAM**

(Refer to Fig. 36)

1	(NOTE 6)	2	(NOTE 3)
3	WIRELESS REMOTE CONTROLLER (RECEIVER/DISPLAY UNIT) (OPTIONAL ACCESSORY)	4	INPUT FROM OUTSIDE (NOTE 7)
5	TRANSMISSION WIRING (NOTE 2) CENTRAL REMOTE CONTROLLER	6	(NOTE 4)
7	WIRED REMOTE CONTROLLER (OPTIONAL ACCESSORY)	8	CONTROL BOX

# WIRING DIAGRAM

INDOOR UNIT		WIRED REMOTE CONTROLLER	
A1P	PRINTED CIRCUIT BOARD	R1T	THERMISTOR (AIR)
C105	CAPACITOR	<b>WIRELESS REMOTE CONTROLLER (RECEIVER / DISPLAY UNIT)</b>	
F1U	FUSE (T, 3.15A, 250V)	A2P	PRINTED CIRCUIT BOARD
HAP	FLASHING LAMP	A3P	PRINTED CIRCUIT BOARD
(SERVICE MONITOR GREEN)		BS1	PUSH BUTTON (ON/OFF)
KPR	MAGNETIC RELAY (DRAIN PUMP)	H1P	PILOT LAMP (ON-RED)
M1F	MOTOR (INDOOR FAN)	H2P	PILOT LAMP (TIMER-GREEN)
M1S	MOTOR (SWING BLADE)	H3P	PILOT LAMP (FILTER SIGN-RED)
PS	POWER SUPPLY CIRCUIT	H4P	PILOT LAMP
R1T	THERMISTOR (AIR)	H4P	PILOT LAMP
R2T	THERMISTOR (COIL)	H4P	PILOT LAMP
R3T	THERMISTOR (COIL)	H4P	PILOT LAMP
V1R	DIODE BRIDGE	SS1	SELECTOR SWITCH
X1M	TERMINAL BLOCK	SS2	SELECTOR SWITCH
X2M	TERMINAL BLOCK	SS2	SELECTOR SWITCH (WIRELESS ADDRESS SET)
Y1E	ELECTRONIC EXPANSION VALVE		
Z1F	NOISE FILTER		

CONNECTOR FOR OPTIONAL PARTS	
X15A	CONNECTOR (FLOAT SWITCH)
X24A	CONNECTOR (WIRELESS REMOTE CONTROLLER)
X25A	CONNECTOR (DRAIN PUMP)
X33A	CONNECTOR (ADAPTOR FOR WIRING)
X35A	CONNECTOR (POWER SUPPLY FOR ADAPTOR)

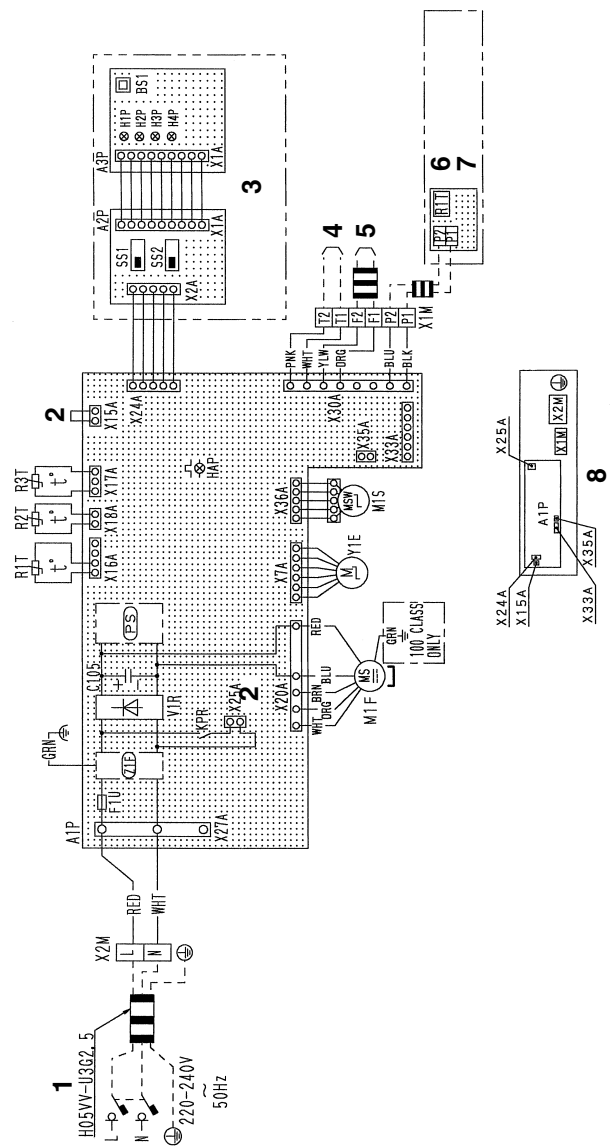

- NOTES**
1. : TERMINAL BLOCK : CONNECTOR : SHORT CIRCUIT CONNECTOR
  2. IN CASE USING CENTRAL REMOTE CONTROLLER, CONNECT IT TO THE UNIT IN ACCORDANCE WITH THE ATTACHED INSTALLATION MANUAL.
  3. X15A, X25A ARE CONNECTED WHEN THE DRAIN UP KIT IS BEING USED. IN ACCORDANCE WITH THE ATTACHED INSTALLATION MANUAL.
  4. IN CASE OF MAIN/SUB CHANGEOVER, SEE THE INSTALLATION MANUAL ATTACHED TO REMOTE CONTROLLER.
  5. SYMBOLS SHOW AS FOLLOWS: BLK: BLACK RED: RED BLU: BLUE WHT: WHITE YLW: YELLOW GRN: GREEN ORG: ORANGE BRN: BROWN.
  6. SHOWS ONLY IN CASE OF PROTECTED PIPES. USE H07RN-F IN CASE OF NO PROTECTION.
  7. WHEN CONNECTING THE INPUT WIRES FROM OUTSIDE, FORCED OFF OR ON/OFF CONTROL OPERATION CAN BE SELECTED BY THE REMOTE CONTROLLER. SEE INSTALLATION MANUAL FOR MORE DETAILS.

