



DESKTOP BARCODE PRINTER
OS-214plus/OS-2140D/
OS-2140/OS-2140Z/
OS-2140DZ/OS-2140E
User's Manual



9001283 (A) - ENG

Proprietary Statement

This manual contains proprietary information of Argox Information Co., Ltd. It is intended solely for the information and use of parties operating and maintaining the equipment described herein. Such proprietary information may not be used, reproduced, or disclosed to any other parties for any other purpose without the expressed written permission of Argox Information Co., Ltd.

Product Improvements

Continuous improvement of products is a policy of Argox Information Co., Ltd. All specifications and signs are subject to change without notice.

FCC Compliance Statement

This equipment has been tested and found to comply with the limits for a Class A digital device, pursuant to Part 15 of the FCC Rules. These limits are designed to provide reasonable protection against harmful interference in a residential installation. This equipment generates, uses, and can radiate radio frequency energy and, if not installed and used in accordance with the instructions, may cause harmful interference to radio communications. However, there is no guarantee that the interference will not occur in a particular installation. If this equipment does cause harmful interference to radio or television reception, which can be determined by turning the equipment off and on, the user is encouraged to try to correct the interference by the following measures:

- Reorient or relocate the receiving antenna.
- Increase the separation between the equipment and the receiver.
- Connect the equipment into a different outlet on a different circuit.
- Consult the dealer or an experience Radio/TV technician for help.

This unit was tested with shielded cables on the peripheral devices. Shielded cables must be used with the unit to insure compliance. The user is cautioned that any changes or modifications not expressly approved by Argox Information Co., Ltd. could void the user's authority to operate the equipment.

Liability Disclaimer

Argox Information Co., Ltd. takes steps to assure that the company's published engineering specifications and manuals are correct; however, errors do occur. Argox Information Co., Ltd. reserves the right to correct any such errors and disclaims any resulting liability. In no event shall Argox Information Co., Ltd. or anyone else involved in the creation, production, or delivery of the accompanying product (including hardware and software) be liable for any damages whatsoever (including, without limitation, damages for loss of business profits, business interruption, loss of business information, or other pecuniary

loss) arising out of the use of or the results of use of or inability to use such product, even if Argox Information Co., Ltd. has been advised of the possibility of such damages.

CAUTION:

Any changes or modifications not expressly approved by the party responsible for compliance could void the user's authority to operate the equipment.

Safety



Supplemental Information: This device complies with the requirement of FCC Part 15 Rules. Operation is subject to the following two Conditions: (1) This device may not cause harmful interference, and (2) this device must accept any interference received, including interference that may cause undesired operation.

INDUSTRY CANADA NOTICE:

This device complies with Industry Canada ICES-003 class A requirements. Cet équipement est conforme a ICES-003 classe A de la norm Industrielle Canadian.



Please only use adapters with the following electrical characteristics and are certified by current legislation. Using other adapters may damage the device and void the warranty also cause risks to the user.

Features Output: 24VDC, 2.4A



The manufacturer declares under sole responsibility that this product conforms to the following standards or other normative documents:

EMC: EN 55022:2006+A1:2007 Class A
EN 55024:1998+A1:2001+A2:2003
EN 61000-3-2:2006+A2:2009
EN 61000-3-3:2008



Argox Information Co., Ltd certifies that the following products and/or components are compliant with the current requirements of the European Union Restriction on the use of Hazardous Substances (RoHS) Directive, 2002/95/EC.

For Support

For any issues or questions, contact SATO America, Inc. using the contact information shown here.

Limitation of liability

SATO Corporation and/or its subsidiaries in Japan, the United States, and other countries make no representations or warranties of any kind regarding this material, including, but not limited to, implied warranties of merchantability and fitness for a particular purpose. SATO Corporation shall not be held responsible for errors contained herein or any omissions from this material or for any damages, whether direct, indirect, incidental or consequential, in connection with the furnishing, distribution, performance or use of this material.

SATO Corporation reserves the right to make changes and/or improvements in this product and document without notice at any time.

SATO America, Inc.
10350A Nations Ford Road
Charlotte, NC 28273
Main Phone: (704) 644.1650
Technical Support: (704) 644.1660
Technical Support Fax: (704) 644.1661
E-Mail: satosales@satoamerica.com
techsupport@satoamerica.com
www.satoamerica.com

© Copyright 2013 SATO America, Inc.
All rights reserved.

Table of Contents

Safety	2
Getting Started	6
Unpacking	6
Package Contents	7
Connecting the Power Supply	8
Getting to Know Your Printer.....	11
Parts and Features	11
Controls and Indicators	14
Loading Ribbon and Media.....	16
Loading Ribbon	16
Loading Media	21
Standard Mode	21
Cutter Mode	26
Calibration and Configuration	28
Performing Calibration and Configuration	28
Resetting to Factory Default Settings	29
Computer Connections	30
USB Interface Requirements	30
Serial (RS-232) Interface Requirements	31
Serial Cabling Requirements	32
Parallel Interface Requirements	33
Ethernet Interface	34
Communicating with the Printer	36
Installing a Plug and Play printer driver (for USB only)	36
Installing the Printer Driver	44
Troubleshooting	56
LED Diagnosis	56
Miscellaneous	59
Recovery	60
Caring for Your Printer	61
Cleaning	61

Media Sensor	61
Thermal Print Head.....	61
Replacing the Thermal Print Head.....	64
Important notice during TPH replacement	66
Technical Reference.....	67
General Specifications	67
Fonts, Bar Codes and Graphics Specification	71
Printer Programming Language A, PPLA	71
Printer Programming Language B, PPLB	72
Printer Programming Language Z, PPLZ.....	73
Interface Specifications.....	75
USB Interface	75
Serial	76
Ethernet.....	77
Parallel (Centronics)	78
Auto Polling.....	78
Connection with host	79
Appendix I - Installing the Cutter	81
Appendix II - Installing the Extension Card	84

Getting Started

Congratulations on choosing the Argox OS-214plus/OS-2140D/OS-2140/OS-2140Z/OS-2140DZ/OS-2140E desktop barcode printers. This manual will help you get to know your new printer. There are two parts to this manual, an operation guide and related information. The operation guide is illustrated to help you quickly become familiar with the printer. The related information includes troubleshooting, maintenance and technical information for your reference.

Unpacking

After receiving your printer, please check for possible shipping damage:

1. Inspect the outside of both the box and the printer for possible damage.
2. Open the top cover of the printer to see if the media compartments are in order.

Note: *If damage has occurred, contact your shipping company immediately to file a claim.*

3. Check whether you have received the following accessories together with the printer. If there are any items missing, please contact your local dealer.

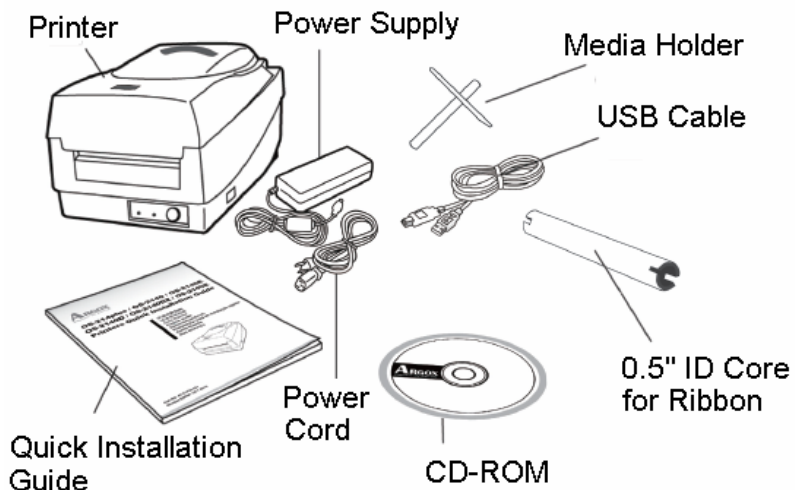

Package Contents

- Printer
- Power Supply
- Power Cord
- Quick Installation Guide
- CD ROM
- USB Cable
- 0.5" ID Core for Ribbon
- Media Holder

Connecting the Power Supply

Connect the power supply as below.

WARNING! Do not operate the printer and power supply in an area where they can get wet.

Make sure the power switch is in the "O" position.

1. Insert the barrel connector of the power supply into the power jack on the back of the printer. Note the location of the power jack for different models in the diagrams below.
2. Insert the separate power cord into the power supply.
3. Plug the other end of the cord into an AC electrical outlet.

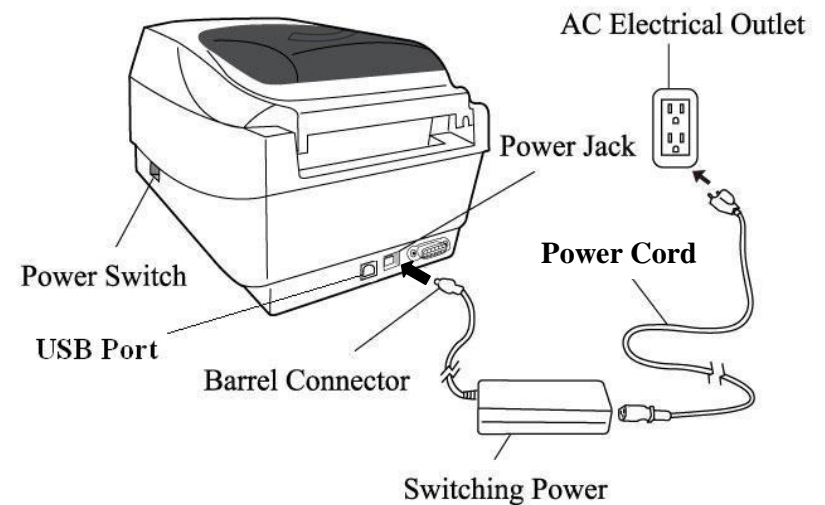

OS-2140D/OS-2140/OS-2140Z/OS-2140D

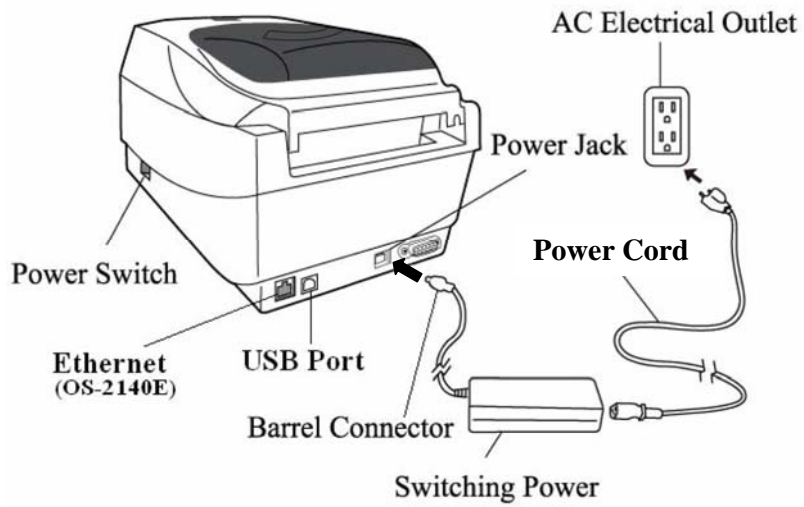

OS-2140E

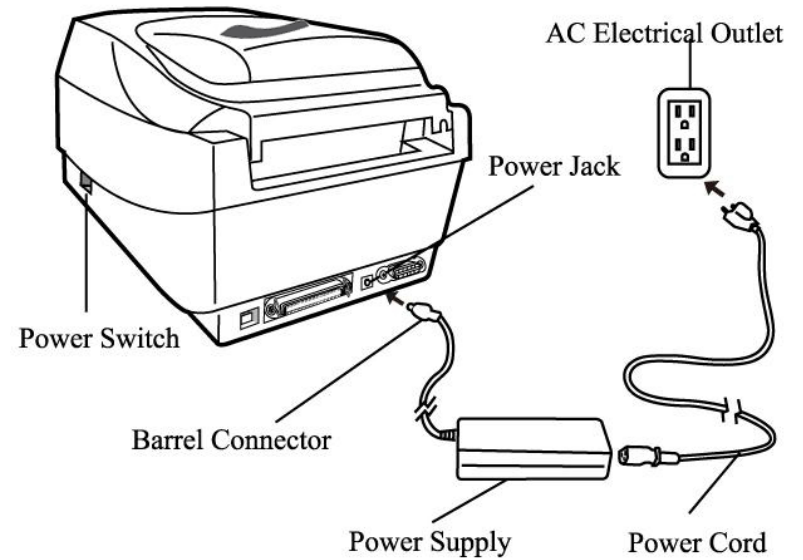

OS-214plus

Getting to Know Your Printer

The illustrations that follow describe the printer's parts, features, controls, and indicators.

Parts and Features

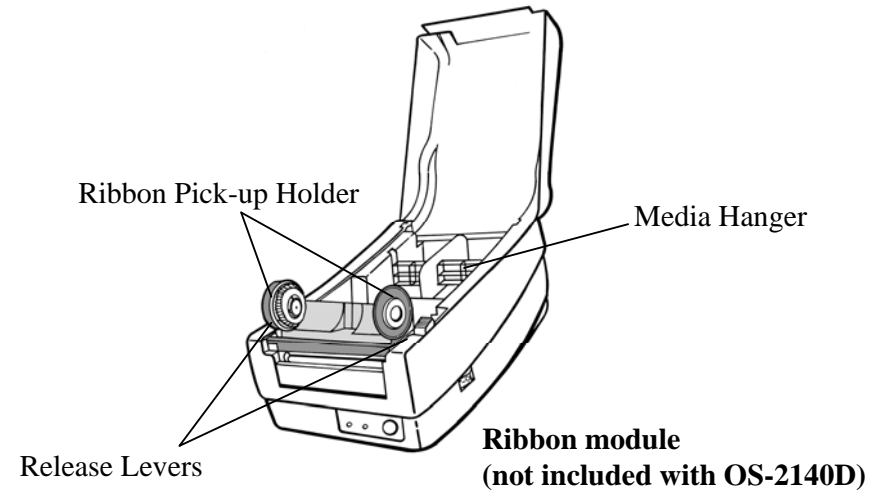
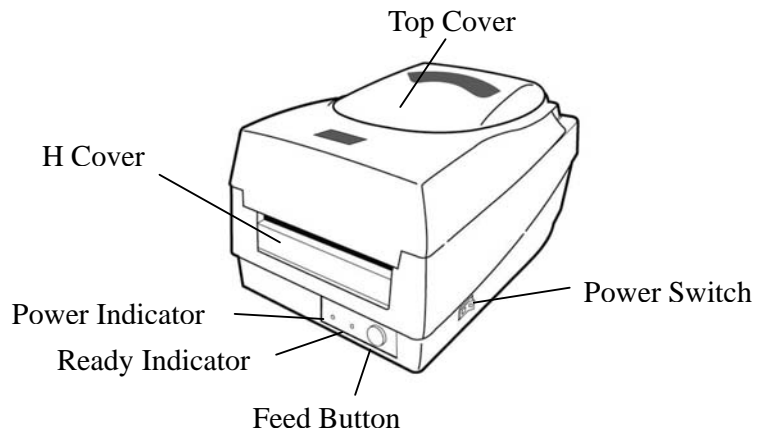

OS-214plus/OS-2140D/OS-2140/OS-2140E/OS-2140Z/OS-2140DZ

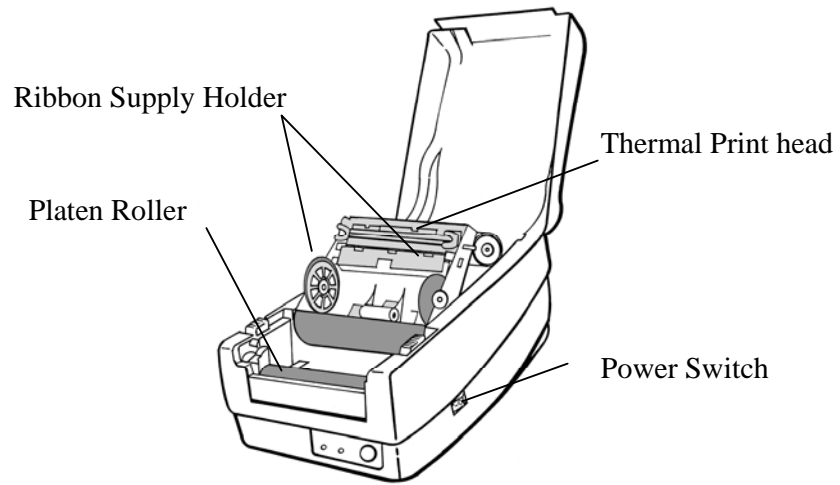

Controls and Indicators

The printer's controls and indicators are shown in the diagram below. The following table explains control and indicator functions.

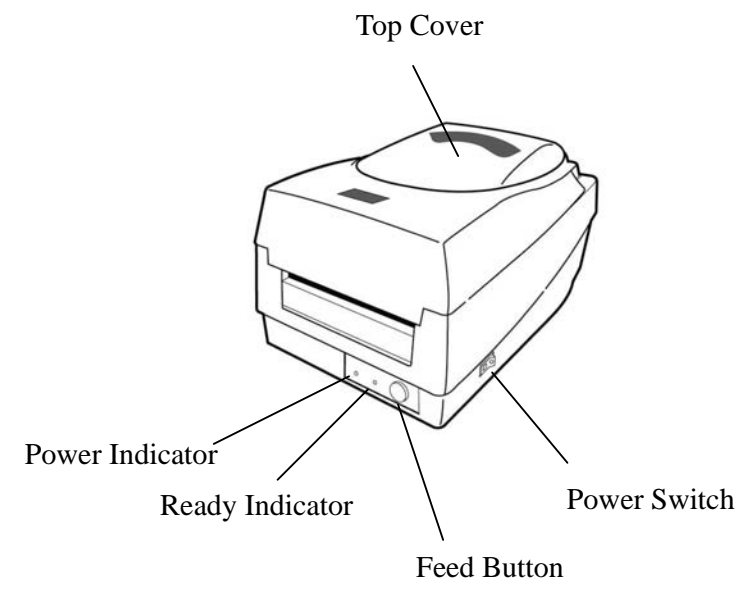

Control / Indicator	Function
Power Switch	<ul style="list-style-type: none"> • On: turns on normal operation • Off: turns off power <p>Note: Turn power off before connecting or disconnecting cables</p>
Power Indicator	<ul style="list-style-type: none"> • Green light shows the power-on • Light off shows the power-off • Blinking light indicates error has occurred
Ready Indicator	<ul style="list-style-type: none"> • Green shows printer is ready to operate • Blinking light indicates printer is paused or data transferring • Seagull driver status monitor
Feed Button	<ul style="list-style-type: none"> • Press to advance labels to the first printing position • Press to take the printer out of "pause" • Press and hold while turning on the power to print out a configuration profile

Loading Ribbon and Media

This section describes how to load ribbon and media in the OS Series printer.

Loading Ribbon

Note: This section does not apply to direct thermal printing.

1. Lift the top cover to expose the media compartment.
2. Unlatch the print head module by pushing the two white release levers on the sides toward the rear.
3. Turn over the print head module to expose the ribbon supply holder.

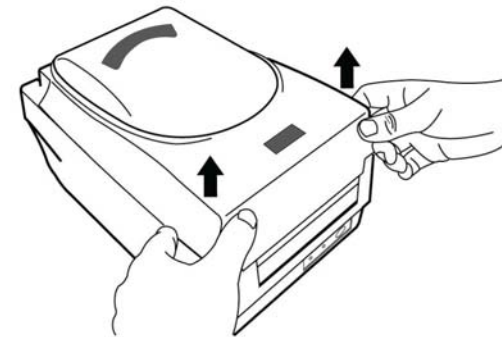

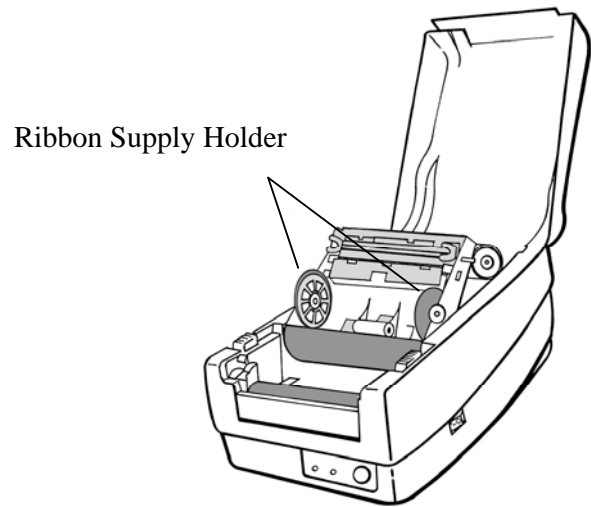
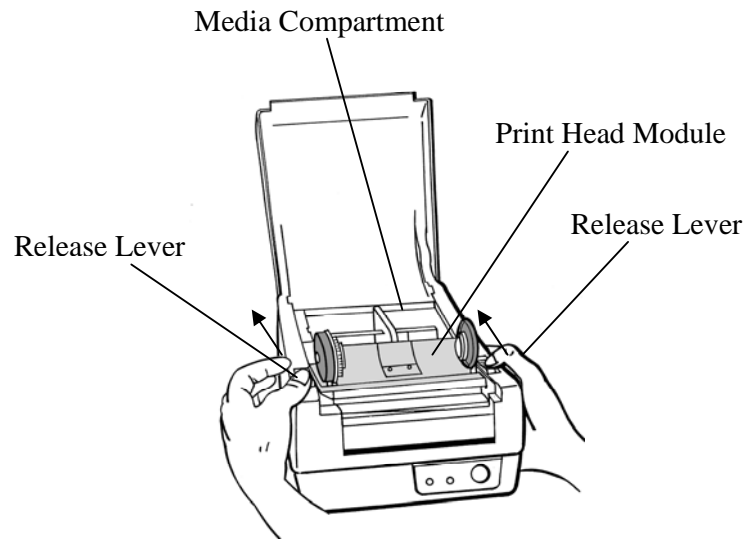

4. Unwrap the ribbon roll pack and separate the ribbon roll and the bare core.
5. Attach the edge of the ribbon on the bare core and wind it a little bit onto the core.
6. Insert the ribbon roll into the supply holder. (First snap in the left side and then the right side.)

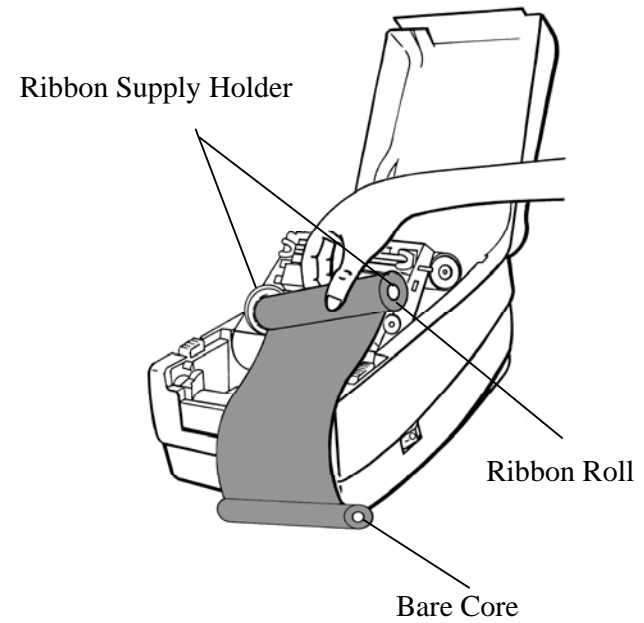

7. Turn back the print head module and then insert the bare core into the pick-up holder. (First snap in the left side, and then the right side.)

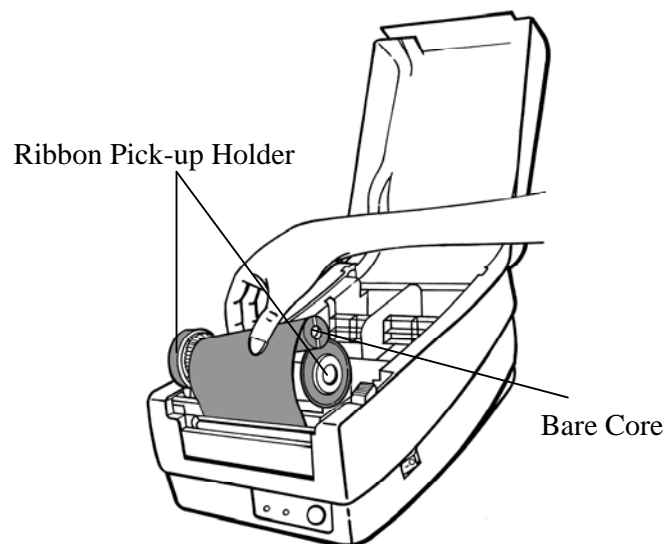

8. Turn the wheel of the print head module to ensure the ribbon is tightly wound.
9. Press down the print head module firmly until you hear a snap.

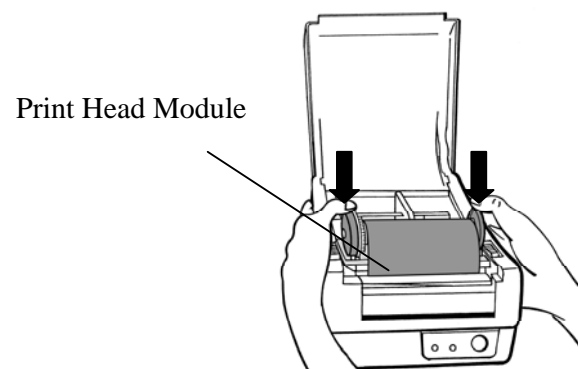
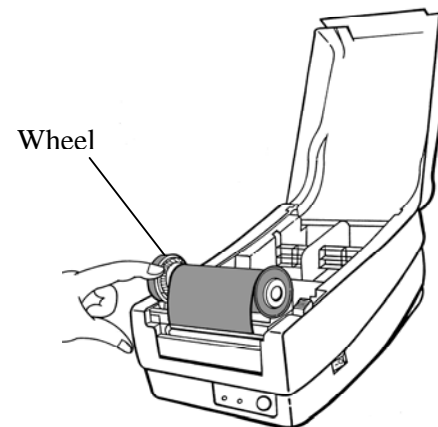

Loading Media

The OS-214plus/OS-2140D/OS-2140/OS-2140Z/OS-2140DZ/OS-2140E printers offer Two different loading modes: standard or with a cutter.

- **Standard mode** allows you to collect each label freely.
- **Cutter mode** automatically cuts the label after it prints.

Standard Mode

1. Lift the top cover to expose the media compartment.

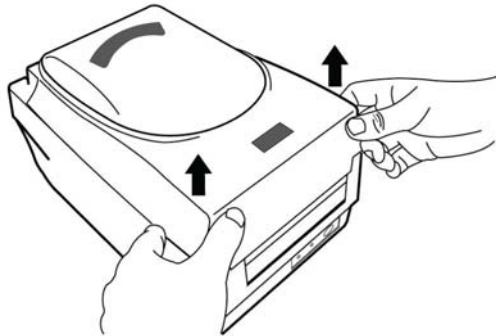

2. Remove the media hanger.

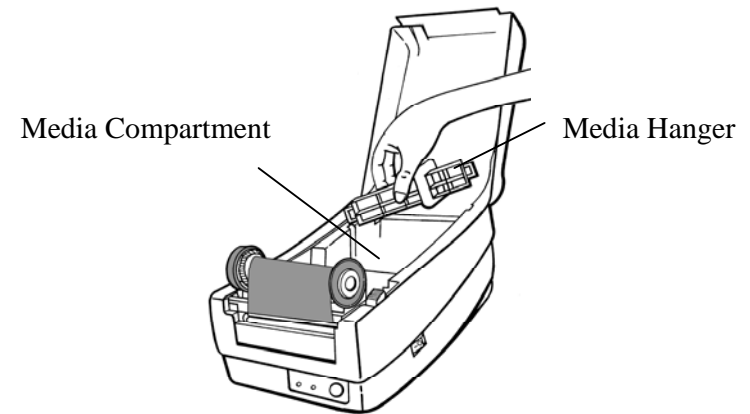

3. Load the media roll onto the hanger from left to right.

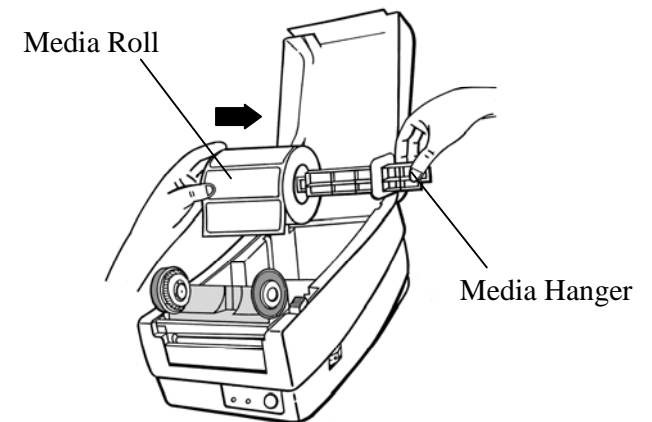

4. Click the media hanger back into the media compartment.
5. Align the media roll to the left end.
6. Move the shield from right to left until it leans against the media.

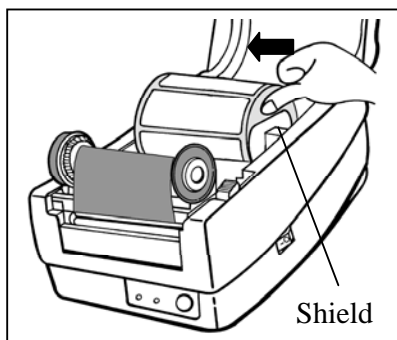
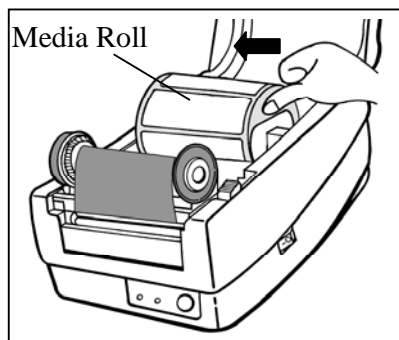
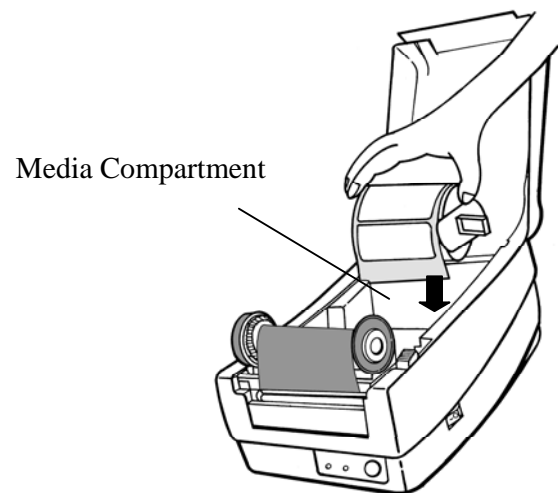

7. Unlatch the print head module.
8. Hold the print head module upright with one hand to allow the media to pass under it. Lead the media through the media guides with the other hand.
9. Lead the media over the platen roller.

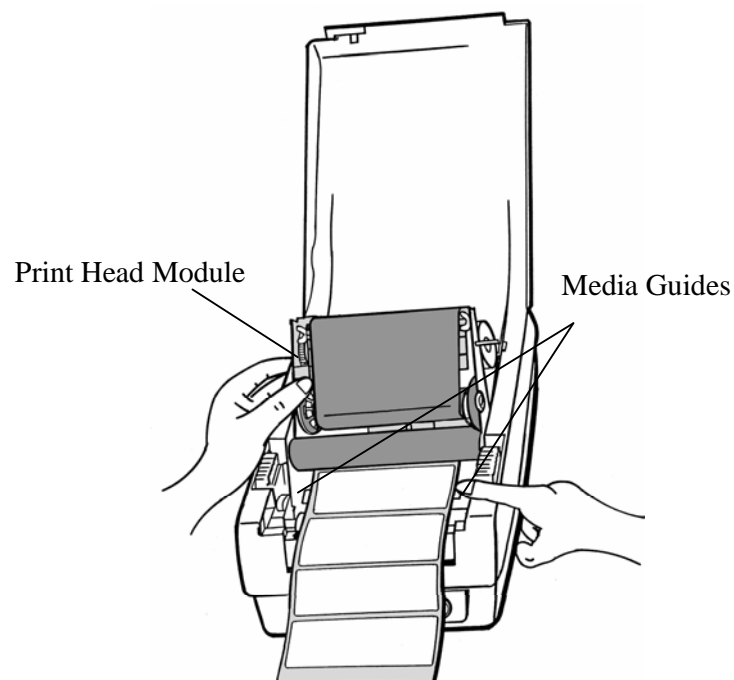

10. Put the print head module down and press down firmly until you hear a snap.
11. Close the top cover and turn on the printer or press the "FEED" button if the printer is already on.

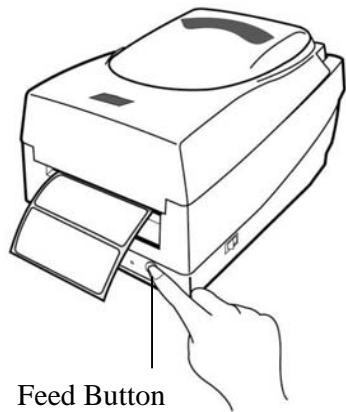
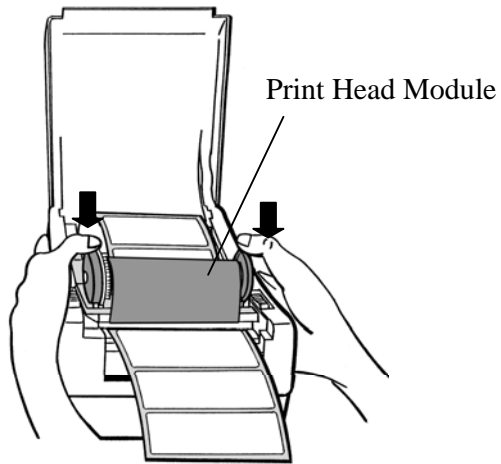

Cutter Mode

Note: For Cutter mode you must first install the cutter and add the cutter baby board to J16 on the main board. Please refer to Appendix I.

Follow Steps 1 to 8 listed in Standard Mode above.

9. Thread the media over the platen roller, then route the media through the slot of the cutter module.
10. Press down the print head module firmly.

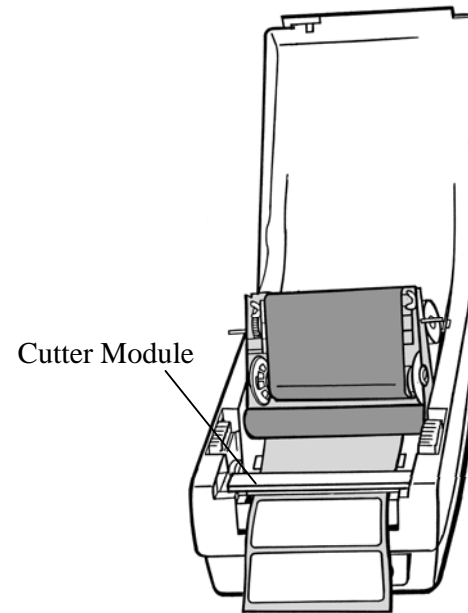

11. Close the top cover and turn on the printer or press the "FEED" button if the printer is already on.

Note: *The "FEED" button does not make the printer cut. Cutting occurs only when the software is properly set.*



Calibration and Configuration

This section discusses calibration, printing configuration and resetting the printer to factory defaults.

Performing Calibration and Configuration

1. Turn off the printer power.
2. Press and hold the feed button while turning on the power, until the printing motor is activated.
3. Calibration is performed while the printer automatically feeds the label stock for a certain length, the printing motor suspends for one second and then prints out a configuration profile.
4. The profile includes firmware version, ROM checksum, RS-232, thermal transfer/direct thermal settings, hardware configuration, and font types.
5. At PPLB emulation, the printer enters character dump mode. To exit from dump mode, press the feed button again. (If you accidentally print the label without exiting from dump mode in advance, you need to turn on the printer or press feed button again to print normally.)

Important! *You must always carry out calibration when changing media. Failure to do so will result in improper detection by the label sensor.*

Resetting to Factory Default Settings

1. Turn on the printer and wait for 5 or more seconds.
2. Press the "Feed" button for 10 seconds, and the "Ready" indicator and "Power" indicator will go off in order.
3. When the two indicators relight, release the feed button.
4. The printer feeds approximately 3 ~5 blank labels, and then resets to the factory defaults.

Note: *Revise the factory default settings that stored in flash, even if turn off the power source cannot be eliminated.*

Computer Connections

Note: *You must insert the power supply's barrel connector into the power jack on the back of the printer before connecting communication cables.*

This printer comes with a nine-pin Electronics Industries Association (EIA) RS-232 serial data interface, a USB interface and Ethernet option. You must supply the required interface cable for your application.

Note: *This printer complies with FCC Rules and Regulations, Part 15, for Class A Equipment, for use with fully shielded six-foot data cables. Use of longer cables or unshielded cables may increase radiated emissions above Class A limits.*

USB Interface Requirements

The Universal Serial Bus (USB) interface is version 2.0 and 1.1 compliant and provides a full-speed (12Mb/s) interface that is compatible with your existing PC hardware. The USB's "plug and play" design makes installation easy. Multiple printers can share a single USB port/hub.

Serial (RS-232) Interface Requirements

The required cable must have a nine-pin "D" type male connector on one end, which is plugged into the mating serial port located on the back of the printer. The other end of the signal interface cable connects to a serial port on the host computer.

For technical and pin-out information, please refer to the Reference Technical Information, Interface Specification.

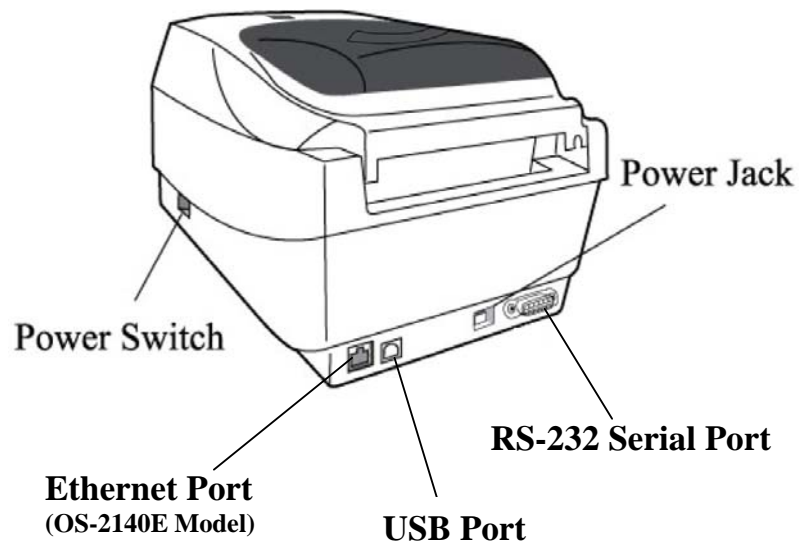

Serial Cabling Requirements

Data cables must be of fully shielded construction and fitted with metal or metalized connector shells. Shielded cables and connectors are required to prevent radiation and reception of electrical noise.

To minimize electrical noise pickup in the cable:

- Keep data cables short (6 ft or 1.83m recommended).
- Do not tightly bundle the data cables with power cords.
- Do not tie the data cables to power wire conduits.

Notes:

Default settings are included in the configuration report.

Parallel Interface Requirements

The required cable (IEEE 1284-compliant is recommended) must have a standard 36-pin parallel connector on one end, which is plugged into the parallel port located on the back of the printer. The other end of the parallel interface cable connects to the printer connector at the host computer. For pin-out information, refer to the Reference Technical Information, Interface Specification.

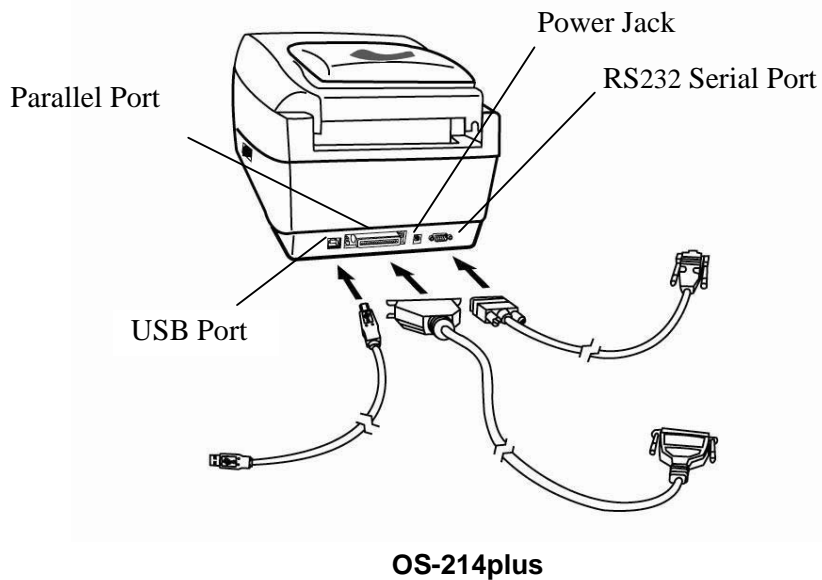

Ethernet Interface

This connector is for Ethernet application; it is convenient to use several printers by Ethernet connector at the same time.

Notes:

When using Ethernet model printer, please wait till the Ready Indicator to stop blinking and then can start to use printer.

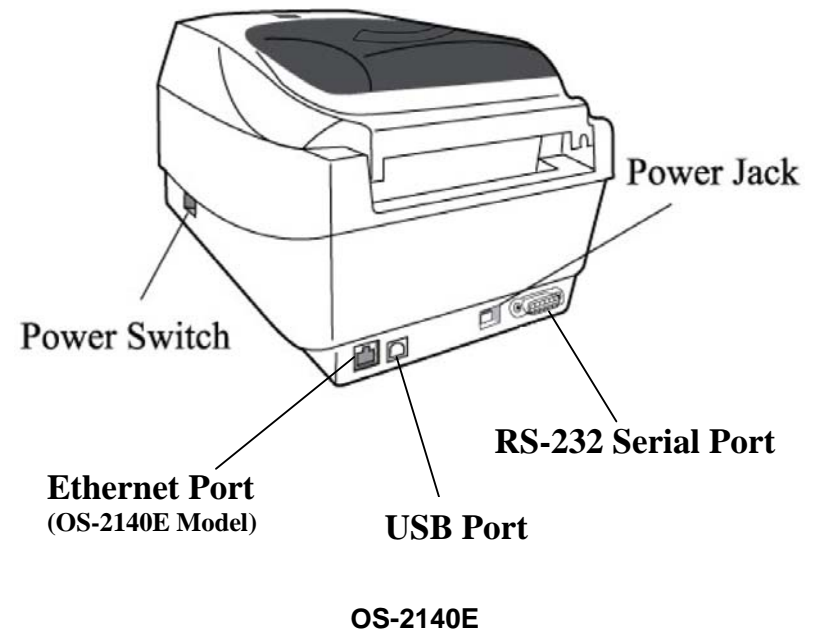

Ethernet Status/Activity Indicators

LED Status	Description
Both Off	No Ethernet link detected
Green LED	Speed LED
	On: 100 Mbps link Off: 10 Mbps link
Amber LED	Link/Activity LED
	On: link up Off: link down Flash: activity

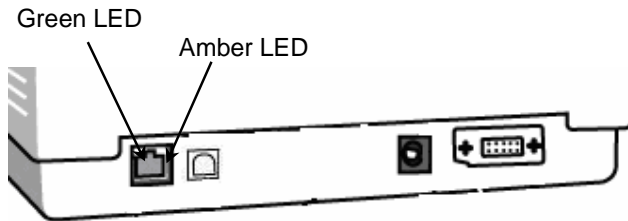

Communicating with the Printer

The bundled printer driver can be applied to all applications under Windows 2003/ XP/ Vista/ Windows 7, supporting 32-bit/ 64-bit operation systems. With this driver you can operate any popular Windows software applications including Argox Bartender UL label editing software or MS Word, etc., to print to this printer.

The following installation steps are based on OS-2140 as an example. The screens included for these steps are taken from Windows XP; steps in other versions of operation systems are similar.

Installing a Plug and Play printer driver (for USB only)

Note:

We strongly recommend that you use the Seagull Driver Wizard instead of the Microsoft Windows Add Printer Wizard when installing and updating your Drivers by Seagull. (Even though the "Add Printer Wizard" is from Microsoft, it too easily performs a number of tasks incorrectly when updating existing drivers. It also badly handles the situation where a printer driver is already in use by a Windows application.)

1. Turn off the printer. Plug the power cable into the power socket on the wall, and then connect the other end of the cable to printer's power socket. Connect the USB cable to the

USB port on the printer and on the PC.

2. Turn on the printer. If the printer supports Plug-and-Play, and you have successfully connected it using a USB cable, then the Windows Add Hardware Wizard will automatically detect the printer and display a dialog that allows you to install a driver. Click Cancel and do not install the driver using this wizard.
3. Prepare the documentation and software CD-Rom from printer package and then install to CD-Rom drive of your computer. The CD-Rom will bring out the following prompt. Click "Go":



4. Under OS-2140 product selection prompt, choose Seagull Driver version and then start installation:



Instead of the flash prompt above, another way to install Seagull driver is to run the DriverWizard utility from the Installation Directory where the Seagull driver files are located.

5. On the Seagull Driver Wizard prompt, select the first radio button to "Install a driver for a Plug and Play printer":

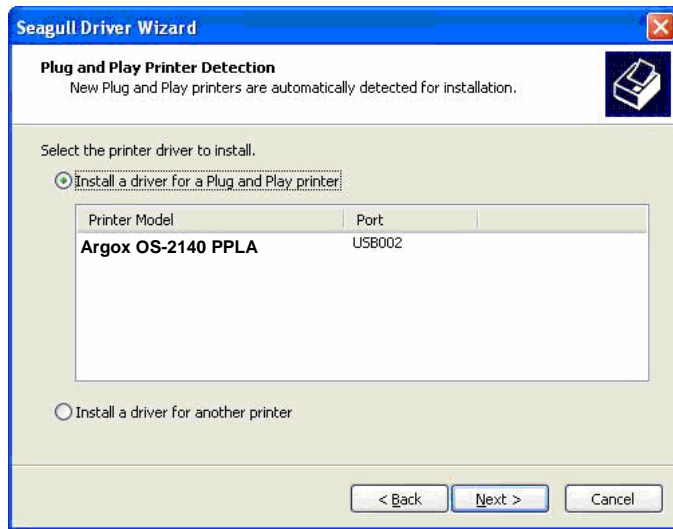

Then click "Next."

6. Enter Printer name (i.e. Arogo OS-2140 PPLA) and select "do not share this printer", and click "Next".

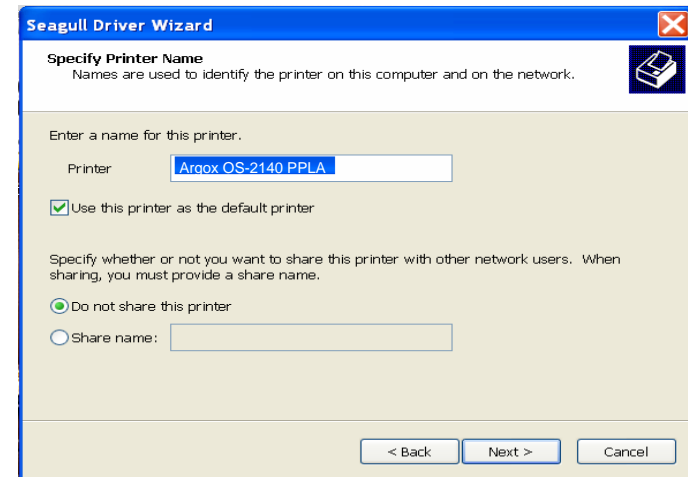

7. Check all the data on the showing screen, if it is correct, click "Finish".



8. After the related files have been copied to your system, click "Finish".

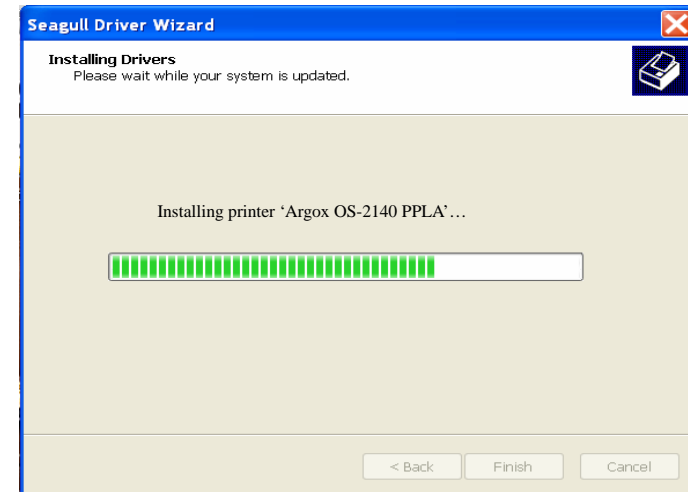

9. After driver installation is complete, click "Close".
The driver should now be installed.

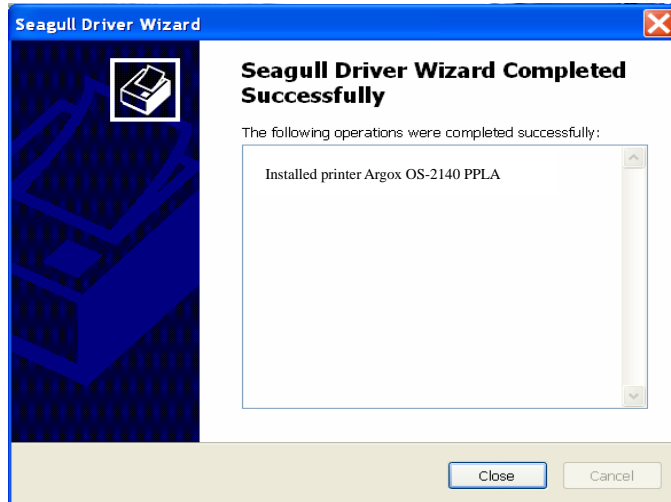

Installing the Printer Driver

1. Turn off the printer. Plug the power cable into the power socket on the wall, and then connect the other end of the cable to printer's power socket. Connect the USB cable, Serial cable, or Ethernet cable to the proper port on the printer and on your computer.
2. Prepare the documentation and software CD-Rom from printer package and then install to CD-Rom drive of your computer. The CD-Rom will bring out the following prompt. Click "Go":



- Under OS-2140 product selection prompt, choose Seagull Driver version and then start installation:



Instead of the flash prompt above, another way to install Seagull driver is to run the DriverWizard utility from the Installation Directory where the Seagull driver files are located.

- On the prompt, Windows Printer Driver, select "I accept..." and click "Next".

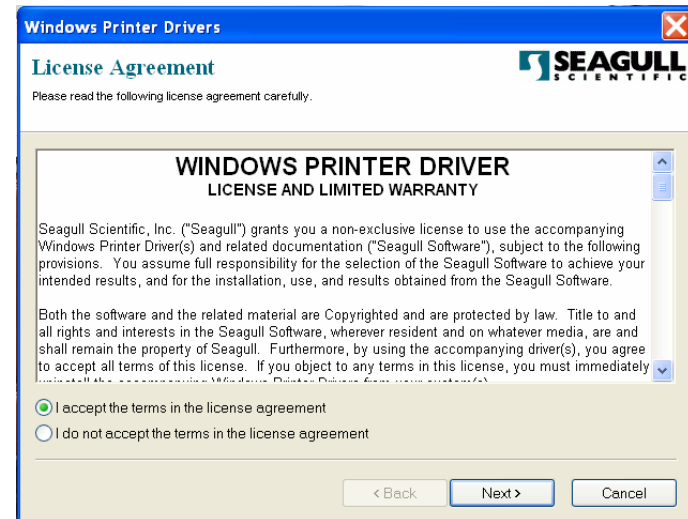

5. Assign the directory to keep Seagull driver, (for example: C:\Seagull) and click "Next".

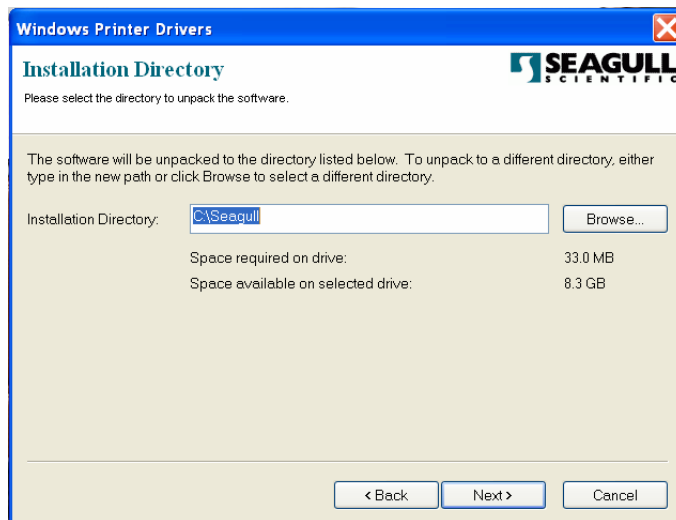

6. Click "Finish".

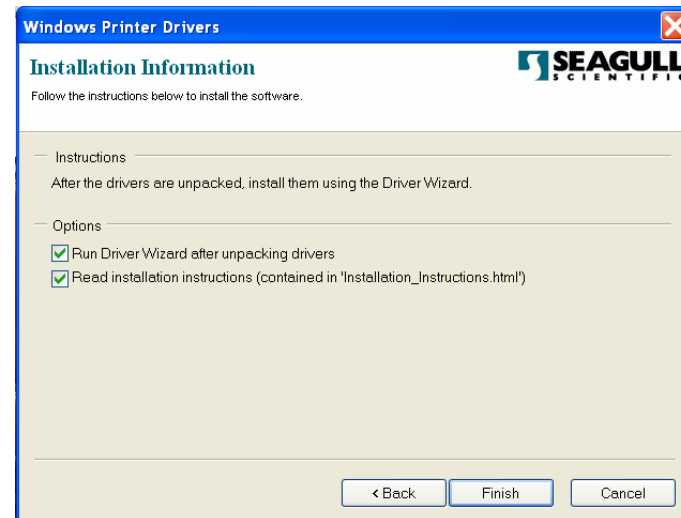

7. Select Install printer drivers and Click "Next"



8. Select model & emulation - the following examples are based on model OS-2140 PPLA:

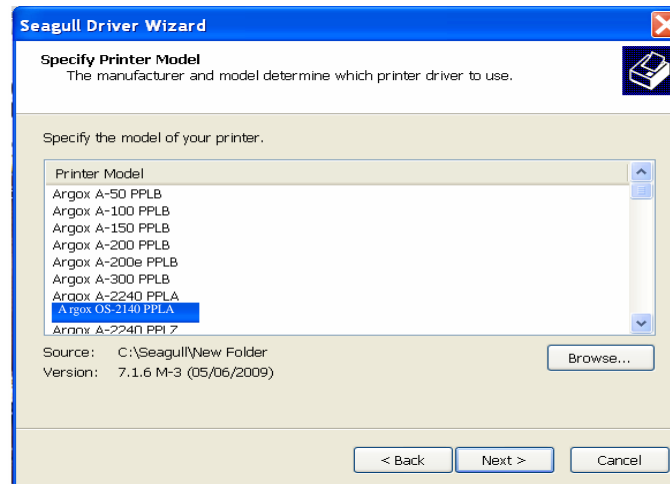

9. Select the port of the printer and click "Next".

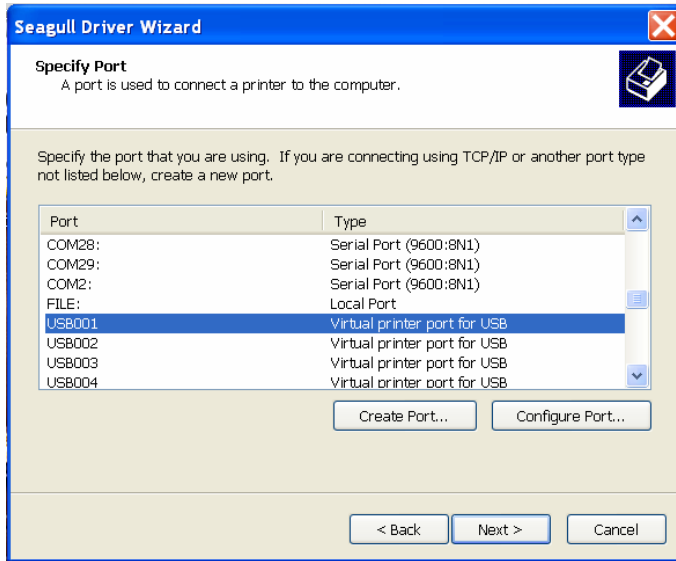

10. Enter Printer name (i.e. Argox OS-2140 PPLA) and select "do not share this printer", and click "Next".

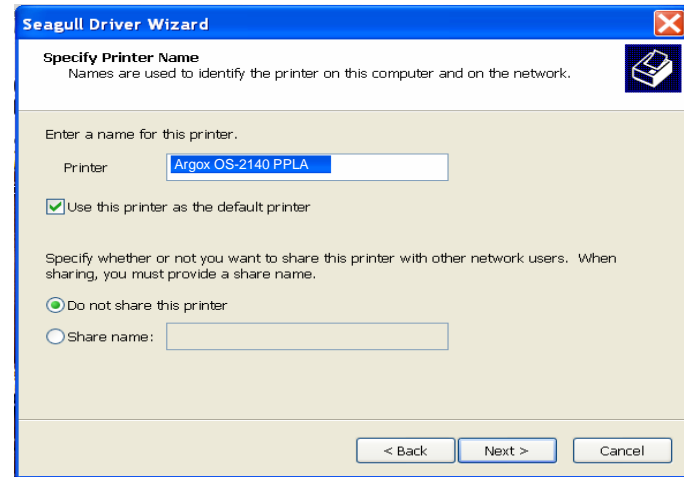

11. Check all the data on the showing screen, if it is correct, click "Finish".



12. After the related files have been copied to your system, click "Finish".

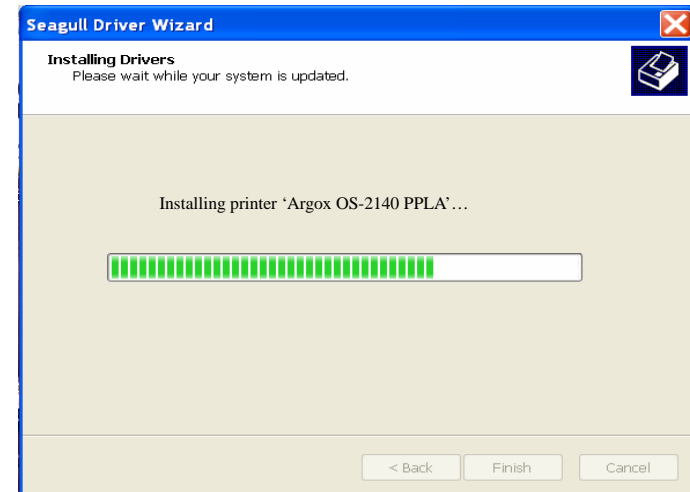

- After driver installation is complete, click "Close".
The driver should now be installed.

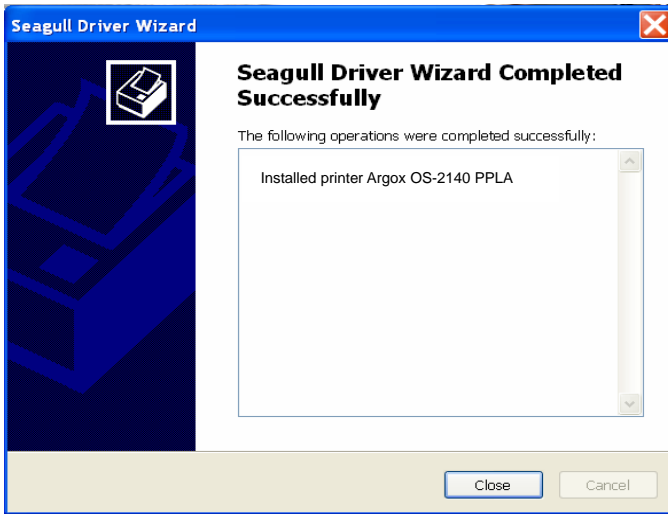

Troubleshooting

Normally, when the printer is not working properly, the "Power" LED blinks continuously; while printing and communication between the host and printer stops.

LED Diagnosis

Power and Ready LEDs blinking continuously indicates printer errors. To understand the problem, please observe the Power and Ready LEDs and refer to the following solutions:

LED Indicators: Power and Ready LEDs blink at the same tempo

Power LED	Ready LED
ON	ON
OFF	OFF

Possible Problems	Solutions	Remarks
Miss-detect gap	Check the label path Check the label sensor	If you use a continuous label roll and run under Windows, select continuous media.
Label stock out	Supply the label roll	
Label stock not installed	Install the label roll	
Label jam	Recover the jam	

LED Indicators: Power and Ready LEDs blink alternately

Power LED	Ready LED
ON	OFF
OFF	ON

Possible Problems	Solutions	Remarks
Ribbon out	Supply the ribbon roll	Not applicable to direct thermal type.
Ribbon jam	Recover the jam	
Ribbon sensor error	Replace ribbon sensor	

LED Indicators: Only the Power LED blinks

Power LED	Ready LED
ON	ON
OFF	ON

Possible Problems	Solutions	Remarks
Serial IO error	Check the baud rate	Serial interface only
Memory full	Add the extension RAM(flash memory card)	
Cutter failed, or jam at cutter	Check the cutter Recover the jam	Occurs only when installing or setting the cutter
Hardware error	Call for service	

LED Indicators: Only the Ready LED blinks

Power LED	Ready LED
ON	ON
ON	OFF

Possible Problems	Solutions	Remarks
Print head too hot	Printing will stop until the print head cools to an acceptable printing temperature. When it does, the printer will automatically resume operation.	

Miscellaneous

If the host shows "Printer Time out"

1. Check if the communication cable (parallel or serial) is connected securely to your parallel or serial port on the PC and to the connector on the printer at the other end.
2. Check if the printer power is turned on.

If the data has been sent, but there is no output from the printer. Check the active printer driver, and see if Seagull driver for your Windows system and the label printer has been selected.

Vertical streaks in the printout usually indicate a dirty or faulty print head. (Refer to the following examples.)

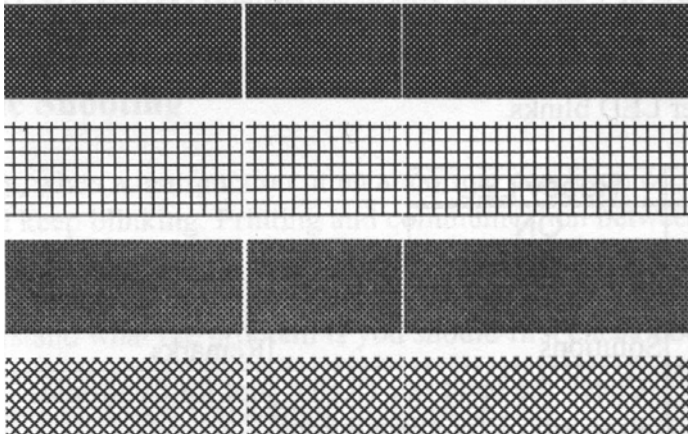

Clean the print head. If the problem persists, replace the print head.

- Poor printout quality:
 - The ribbon may not be qualified.
 - The media may not be qualified.
 - Adjust the Darkness (heat temperature).
 - Slow down the print speed.
 - Refer to the next chapter and clean the related spare parts.

Recovery

After correcting problems, simply press the panel button or restart the printer to continue your print jobs. Make sure the LEDs are not blinking and remember to resend your files.

Caring for Your Printer

Adhesives and coatings of media can over time transfer onto the printer components along the media path including the thermal print head and media sensor. This build-up can accumulate dust and debris. Failure to clean the print head, media path, and media sensor could result in inadvertent loss off labels, label jams and possible damage to the printer.

Note: *Turn off the printer before cleaning.*

Cleaning

Clean the following components of the printer using a cotton bud dampened with alcohol. Do not soak the cotton bud excessively.

Media Sensor

Debris or dirt on the paper sensor can cause a miss-read or unstable detection of the label gap. Clean with a cotton bud dampened with alcohol.

Thermal Print Head

Thermal paper stock and the ribbon release debris on the print head, which degrades printing quality. Clean the print head with methanol or isopropyl alcohol and a cotton bud. Do not touch the heater element with your fingers. Debris or dirt on the roller should be cleaned with alcohol.

TPH Cleaning Interval:

It's strongly recommended to regularly clean print heads at least when changing every one ribbon roll (in thermal transfer printing mode), or every one label roll (in direct thermal printing mode). In addition, if printers are operated under critical applications and environments, or it's found print quality is degraded, please clean print heads more frequently.

TPH Cleaning Material:

Surface of print head's heating element is very fragile. To prevent from any possible damage, please use soft cloth or cotton buds with "Ethanol" or "industry alcohol" to clean print head surface.

It's strongly recommended to wear hand gloves during cleaning progress.

Do not touch print head surface by bare hands or with any hard equipment. Water or spit should be kept away in case of corrosion on heating elements.

TPH Cleaning Direction:

When cleaning print head, please always wipe in One-Way Direction - from Left to Right only, or, from Right to Left only, to clean "Heating Line" of print head gently without excessive stress.

Do not wipe back and forth, to avoid dust, dirt, or ribbon residue on cleaning cotton would be attached onto print head again. (Please refer to below picture)

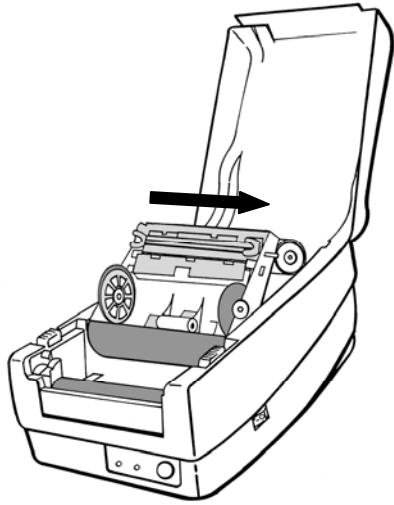

Special Caution:

Warranty of print heads will be void if print head serial number is removed, altered, defected, or made illegible, under every circumstance.

Replacing the Thermal Print Head

1. Switch off the power and wait for both LEDs to go off.
2. Unlatch the print head module.
3. Remove the ribbon.
4. Push the print head firmly into the casing and shift it to the left. It will release from the module.

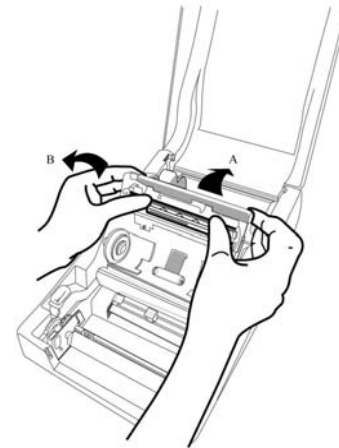

5. Disconnect the print head cable.

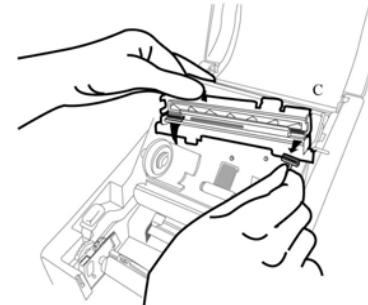

6. Disassemble the print head and the mounting bracket by releasing screws.
7. Replace with a new print head. Reassemble the print head module in reverse order. Be careful not to touch the print head elements.

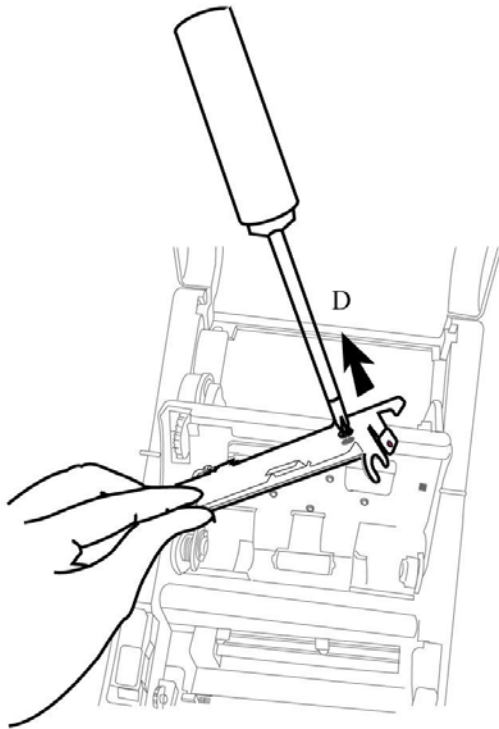

Important notice during TPH replacement

1. Heater line should NOT be touched by bare hands to prevent any damage caused by ESD or corrosion.
2. Surface of heaters should NOT be hit or scratched by sharp or hard things to prevent any damage by scratch.
3. Residue or contamination should NOT be removed by a cutter to prevent any damage by dent or scratch.
4. Connector side should NOT be touched when cleaning TPH to prevent delaminated solder between FPC and wafer. Ink-jet characters could be erased, if cleaning cloth was touched them on FPC or label.
5. Heater surface should be free from any condensation.
6. TPH should NOT be put heater surface down.



Technical Reference

General Specifications

Specification	OS-2140D	OS-2140	OS-214plus
Printing method	Direct Transfer	Direct Transfer/Thermal Transfer	
Printing resolution	203 dpi (8dots/mm)		
Printing speed	Up to 4ips (102mm/s)	2~3ips(51~76mm/s)	
Printing length	Max 100" (2540mm)	Max 43"(1092mm)	
Printing width	Max 4.16" (105mm)		
Memory	8MB DRAM(6MB user available) 4MB Flash ROM(2MB user available)		
CPU type	32 bit RISC microprocessor		
Media sensor	Reflective x 1		
Operation interface	LED indicator(Power/Ready)x2, Button(Feed)x1		
Communication Interface	RS-232(Baud rate 2400 ~ 115200 bps), USB(2.0)	Centronics Parallel, RS-232(Baud rate 2400 ~ 115200 bps), USB(2.0)	
Fonts	Internal character sets standard 5 alpha-numeric fonts from 0.049"H ~ 0.23" H (1.25mm ~ 6.0mm) Internal fonts are expandable up to 24x24 4 direction 0 ~ 270 rotation Soft fonts are downloadable		

1D Barcodes	<p>OS-2140 & OS-2140D: PPLA: Code 39 (standard/with checksum digit), Code 93 Interleaved 2 of 5 (standard/with checksum digit/with human readable check digit), EAN-8, EAN-13,UPC-A, UPC-E, Postnet, Codabar, Code 128 subset A/B/C, UCC/EAN-128, UCC/EAN-128 K-MART, UCC/EAN-128 , Random Weight, Plessey, HBIC, Telepen, FIM, UPC2, UPC5, GS1 Data Bar PPLB: Code 39 (standard/with checksum digit),Code 93 Interleaved 2 of 5 (standard/with checksum digit/with human readable check digit), EAN-8 (standard/2 digit add-on/5 digit add-on), EAN-13 (standard/2 digit add-on/5 digit add-on), UPC-A (standard/2 digit add-on/5digit add-on), UPC-E (standard/2 digit add-on/5 digit add-on), Postnet, Codabar, Code 128 subset A/B/C, Code 128 UCC (Shipping Container Code), Code 128 Auto, German, Postcode, Matrix 2 of 5, UCC/EAN 128, UPC Interleaved 2 of 5, GS1 Data Bar PPLZ: Code 39 (standard/with checksum digit), Code 93 Interleaved 2of 5 (standard/with checksum digit/with human readable check digit), EAN-8, EAN-13, UPC-A, UPC-E, Postnet, Codabar, Code 128 subset A/B/C, Code 128 Auto, UPC/EAN-Extension, Plessey, Industrial 2 of 5 , Standard 2 of 5, Logmars, MSI, Code 11, GS1 DataBar</p> <p>OS-214plus: PPLA: Code 39, Code 93,Code 128/subset A/B/C, Codabar, Interleaved 2 of 5, UPC A/E/2/5 add-on, EAN-13/8, UCC/EAN 128, Postnet, Plessey, Interleaved 2 of 5, Interleaved 2 of 5 with a modulo 10 checksum, Interleaved 2 of 5 with a modulo 10 checksum and shipping bearer bars , Code 128, UCC/EAN Code 128 Random Weight, HBIC, Telepen , FIM PPLB: Code 39, Code 93, Code 128/ subset A,B,C, Codabar, Interleaved 2 of 5, Interleaved 2 of 5 with check sum digit, Interleaved 2 of 5 with human readable check digit, Matrix 2 of 5, UPC A/E 2 and 5 add-on, EAN-8/13, Code 128UCC, UCC/EAN, Postnet</p>
-------------	--

2D Barcodes	OS-2140 & OS-2140D: PPLA/PPLB/PPLZ: MaxiCode, PDF417, Data Matrix (ECC 200 only), QR code, Composite codes OS-214plus: PPLA: PDF-417, MaxiCode, Data Matrix (ECC200 only) ,QR Code, Composite codes PPLB: MaxiCode, PDF-417, QR Code, Composite codes	
Graphic	OS-2140 & OS-2140D: PPLA/PPLB: PCX, BMP, IMG, HEX,GDI, Binary raster(PPLB Only) PPLZ: GRF, Hex and GDI OS-214plus: PPLA: PCX, BMP, IMG, HEX ,GDI PPLB: PCX, Binary raster , GDI	
Emulation	PPLA/PPLB/PPLZ (OS-2140Z,OS-2140DZ only)	
Software-Label editing	Windows Driver (Win 2003/XP/Vista/Windows 7) BarTender ,	
Software-Utility	Printer Utility, Font Utility	
Media Type	Roll-feed, die-cut, continuous, fan-fold, tags, ticket in thermal paper or plain paper and fabric label	
Media	Max Width:4.33"(110mm) Min Width:1"(25.4mm) Thickness:0.0025"~0.01"(0.0635~0.254mm) Max roll capacity(OD):4.3"(109mm) Core size:0.5"(12.7mm) (1"(25.4mm) optional)	
Ribbon	N/A	Ribbon Width: 1"~4" Ribbon roll – max OD: 1.45"(37mm) Ribbon Length: max 92m Core size – ID: 0.5"(13mm) with notch Wax, Wax/Resin, Resin (Outside Ribbon)
Dimensions	W 186mm x H 153mm x L 278mm	
Weight	2.0kgs	
Power Source	Universal Switching Power Supply Input: 100V~240V, 1.5A, 50~60Hz, Output: 24VDC, 2.4A	
Operation Environment	Operation Temperature: 40°F~100°F (4°C~38°C), 10% ~ 90% non-condensing, Storage Temperature: -4°F~122°F (-20°C~50°C)	

Optional Items	Cutter, Stacker, RTC Card, ArgoKee, 2MB Asian Font Card (Traditional Chinese, Simplified Chinese, Korean and Japanese)
Agency Listing	CE, FCC, cTUVus, CCC, 

Fonts, Bar Codes and Graphics Specification

The specifications of fonts, bar codes and graphics depends on the printer emulation. The emulations PPLA, PPLB and PPLZ are printer programming languages, through which the host can communicate with your printer.

Printer Programming Language A, PPLA

Programming Language	PPLA
Internal fonts	9 fonts with different point size 6 fonts with ASD smooth font. Courier font with different symbol sets.
Symbol sets (Code pages)	Courier font symbol set: Roman-8, ECMA-94, PC, PC-A, PC-B, Legal, and PC437 (Greek), Russian.
Soft fonts	Downloadable soft fonts
Font size	1x1 to 24x24 times
Character rotation	0, 90, 180, 270 degree, 4 direction rotation
Graphics	PCX, BMP, IMG, HEX, GDI
Bar code types	Code 39 (standard/with checksum digit), Code 93 Interleaved 2 of 5 (standard/with checksum digit/with human readable check digit), EAN-8, EAN-13, UPC-A, UPC-E, Postnet, Codabar, Code 128 subset A/B/C, UCC/EAN-128, UCC/EAN-128 K-MART, UCC/EAN-128, Random Weight, Plessey, HBIC, Telepen, FIM, UPC2, UPC5, GS1 Data Bar

Printer Programming Language B, PPLB

Programming Language	PPLB
Internal fonts	5 fonts with different point size
Symbol sets (Code pages)	8 bits code page : 437, 850, 852, 860, 863, 865, 857, 861, 862, 855, 866, 737, 851, 869, 1252, 1250, 1251, 1253, 1254, 1255 7 bits code page: USA, BRITISH, GERMAN, FRENCH, DANISH, ITALIAN, SPANISH, SWEDISH and SWISS.
Soft fonts	Downloadable soft fonts
Font size	1x1 to 24x24 times
Character rotation	0, 90, 180, 270 degree, 4 direction rotation
Graphics	PCX, BMP, IMG, HEX, GDI, Binary raster
Bar code types	Code 39 (standard/with checksum digit), Code 93 Interleaved 2 of 5 (standard/with checksum digit/with human readable check digit), EAN-8 (standard/2 digit add-on/5 digit add-on), EAN-13 (standard/2 digit add-on/5 digit add-on), UPC-A (standard/2 digit add-on/5 digit add-on), UPC-E (standard/2 digit add-on/5 digit add-on), Postnet, Codabar, Code 128 subset A/B/C, Code 128 UCC (Shipping Container Code), Code 128 Auto, German, Postcode, Matrix 2 of 5, UCC/EAN 128, UPC Interleaved 2 of 5, GS1 Data Bar

Printer Programming Language Z, PPLZ

Programming Language	PPLZ
Internal fonts	8 (A~H) fonts with different point size. 8 AGFA fonts: 7 (P~V) fonts with fixed different point size (can't scale). 1 (0) font with scaling point size.
Symbol sets (Code pages)	USA1, USA2, UK, HOLLAND, DENMARK, NORWAY, SWEDEN/FINLAND, GERMAN, FRANCE1, FRANCE2, ITALY, SPAIN, MISC, JAPAN, IBM850.
Soft fonts	Downloadable soft fonts
Font size	1x1 to 10x10 times
Character rotation	0, 90, 180, 270 degree, 4 direction rotation
Graphics	GRF, Hex and GDI
Bar code types	Code 39 (standard/with checksum digit), Code 93 Interleaved 2of 5 (standard/with checksum digit/with human readable check digit), EAN-8, EAN-13, UPC-A, UPC-E, Postnet, Codabar, Code 128 subset A/B/C, Code 128 Auto, UPC/EAN-Extension, Plessey, Industrial 2 of 5, Standard 2 of 5, Logmars, MSI, Code 11, GS1 DataBar

Notes:

1. *The bare core for the ribbon must be 11 cm in length. It should have two opposite slits at two ends. If the ribbon itself is less than 11 cm, it must be aligned with the bare core in the left side when you install it.*

Interface Specifications

USB Interface

This port complies with USB 2.0 Full Speed.

Connector Terminal Pin Assignment

Pin	Signal	Description
1	VBUS	5V
2	D -	Differential data signaling pair -
3	D +	Differential data signaling pair +
4	GND	Ground

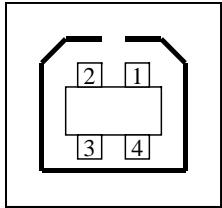

USB series "B" Receptacle Interface

Serial

The RS232 connector on the printer side is a female, DB-9.

Pin	Direction	Definition
1		Shorted to Pin 6
2	In T	RxData
3	Out	TxDData
4		N.C.
5		Ground
6		Shorted to Pin 1
7	Out	RTS
8	In	CTS
9	Out	+5V

Note :

Pin 9 are reserved for KDU (keyboard device unit), therefore do not connect these pins if you are using a general host like a PC.

Ethernet

The following port complies with Ethernet communication.

Pin	Signal
1	Transmit+
2	Transmit-
3	Receive+
4	Reserved
5	Reserved
6	Receive-
7	Reserved
8	Reserved

Parallel (Centronics)

The parallel port is a standard 36-pin Centronics, which complies with IEEE 1284 standard (compatibility mode). Pin assignments are as follows:

Pin	Direction	Definition	Pin	Direction	Definition
1	In	n/STROBE	16	-	Ground
2~9	In	Data 1~8	17	-	Chassis Ground
10	Out	nACK	18	-	Peripheral High
11	Out	BUSY	19~30	-	Signal Ground
12	Out	PE	31	In	nINIT
13	Out	SELECT	32	Out	nFAULT
14	In	nAUTOFEED	33~35	-	N.D.
15	-	N.D.	36	In	nSELECTIN

Auto Polling

Both the serial port and parallel port of this printer can be activated at the same time, i.e the printer can simultaneously communicate with two PCs via different ports. However as no port contention is made for this printer, if both PCs transmit data at the same time the data may become damaged in the receiving buffer.

Connection with host

Host 25S (PC or compatible)	Printer 9P	Host 9S (PC or compatible)	Printer 9P
DTR 20 1 DSR	DTR 4 1 DSR
DSR 6 6 DTR	DSR 6 6 DTR
TX 2 2 RX	TX 3 2 RX
RX 3 3 TX	RX 2 3 TX
CTS 5 7 RTS	CTS 8 7 RTS
RTS 4 8 CTR	RTS 7 8 CTS
GND 7 5 GND	GND 5 5 GND

Alternatively you can just connect the 3 wires in the following way.

Host 25S (PC or compatible)	Printer 9P	Host 9S (PC or compatible)	Printer 9P
TX 2 2 RX	TX 3 2 RX
RX 3 3 TX	RX 2 3 TX
GND 7 5 GND	GND 5 5 GND
pin 4	<input type="text"/>	pin 4	<input type="text"/>
pin 5	<input type="text"/>	pin 6	<input type="text"/>
pin 6	<input type="text"/>	pin 7	<input type="text"/>
pin 20	<input type="text"/>	pin 8	<input type="text"/>

The simplest way to connect to other hosts (not PC compatible) or terminals is:

Printer		Terminal/Host
Pin 2- RxData	TxDATA
Pin 3- TxData	RxDATA
Pin 5- Ground	Ground

In general, as long as the data quantity is not too large and you use Xon/Xoff as flow control, it will be problem free.

Baud rate: 2400, 4800, 9600(default), 19200, 38400, 57600, 115200 bauds.(programmable by command)

Data format: always 8 data bits, 1 start bit and 1 stop bit.

Parity: always non parity

Handshaking: XON/XOFF as well as CTS/RTS (hardware flow control).

If you run an application with the bundled printer driver under Windows and use the serial port, you should check the above parameters and set the flow control to "Xon/Xoff "or "hardware".

Appendix I - Installing the Cutter

1. Turn off the printer power and unplug the power cable and Serial / USB cable.
2. Remove the top cover.
3. Remove the two screws under the base housing.

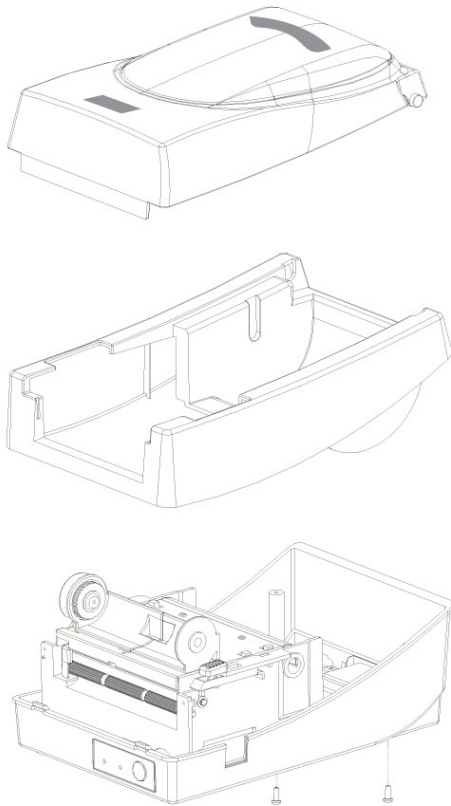

4. Remove the whole print head assembly by releasing the 4 screws at its feet.

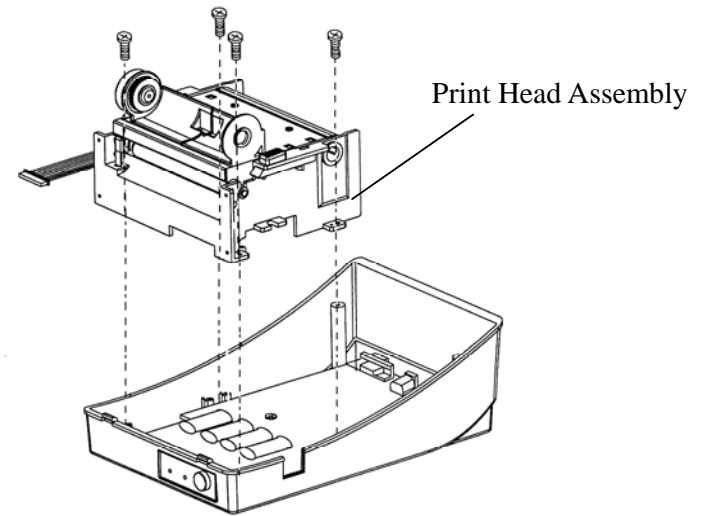

5. Add the cutter baby board to J16 on the main board.

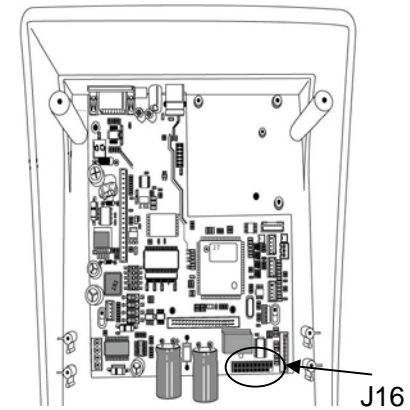

6. Secure the four screws attaching the cutter.

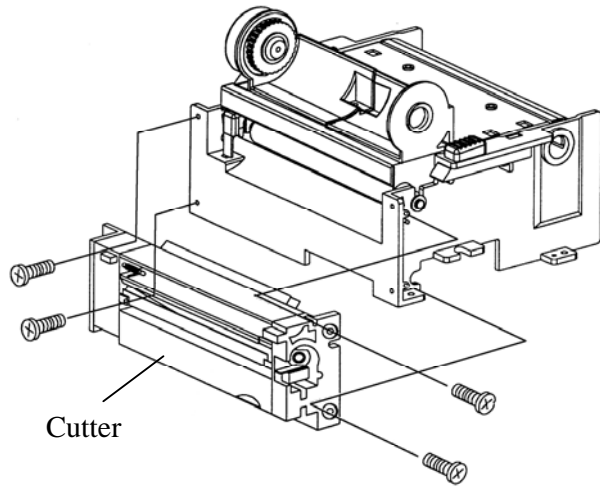

7. Plug the cutter's connector into the PCB's header connector (J9).
8. Reattach the print head assembly by securing the 4 screws.
9. Click back the middle cover.
10. Secure the two screws for the base housing.
11. Click the top cover into place.

Appendix II - Installing the Extension Card

Extension Card designated for all optional extension modules. For example, RTC card and Add-on card.

Install the extension card into the printer as follows:

1. Turn off the printer power.
2. Remove the top cover.
3. Release the two screws at the bottom of the base housing.

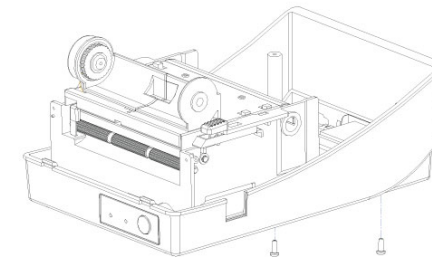
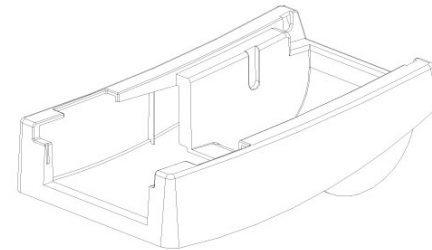
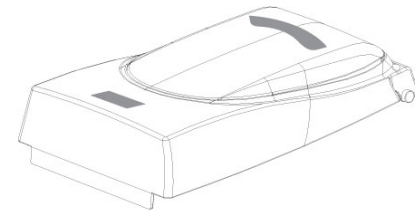

4. Remove the middle cover.

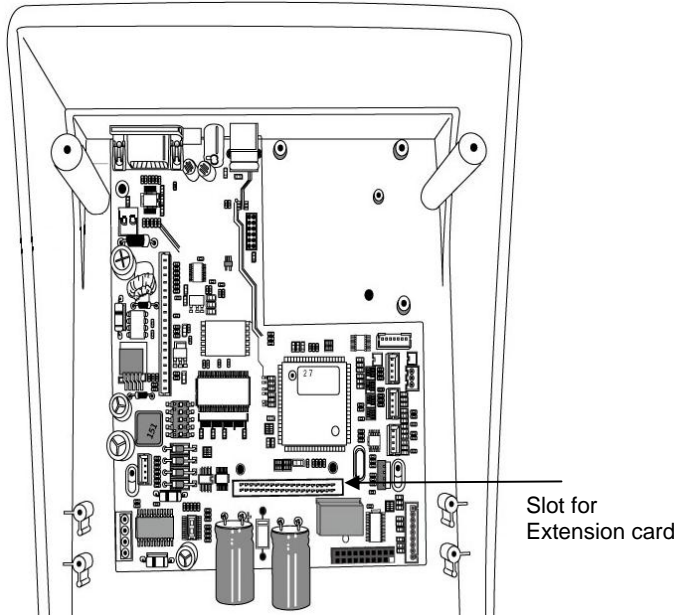

5. Mount the extension card to J14 on the main board.

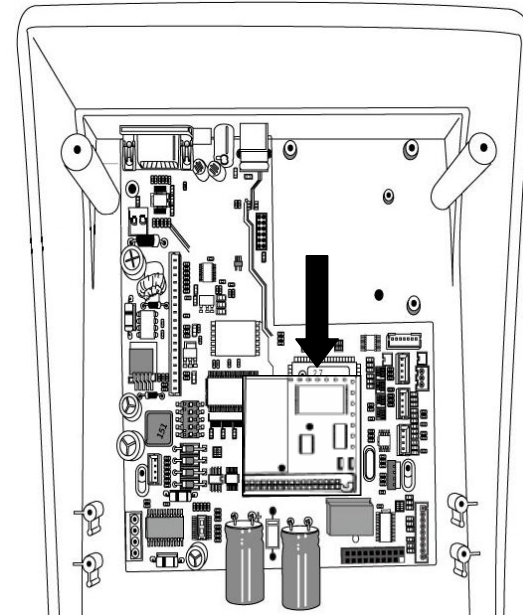

6. Click back the middle cover.
7. Secure the two screws for the base housing.
8. Click the top cover into place.