



RC-100BZ Heat Pump 2 Stage Heat / 1 Stage Cool Thermostat Installation Instructions

DESCRIPTION

The RC-100BZ is a precision digital thermostat designed for 24 VAC heat pump systems. It has the capability of being controlled both locally and by remote control over a Z-Wave network. It offers programmability, stand-alone operation, and communications with automation systems, utility control systems, or personal computers over a Z-Wave network. The RC-100BZ is equipped with a “cool blue” backlight display.

Electrical rating:	24 V; 3 A; 50/60 Hz
Maximum current:	2 A on any circuit, 3 A total
Thermostat operating current:	less than 15 mA

The following requirements must be observed for installation in Europe: CE

1. This equipment must be installed in accordance with National wiring rules for the country in which it is installed.
2. Fuses must be replaced only with IEC rated components.
3. All product labels, instructions and markings relating to safety must be translated to a language, which is acceptable in the country in which this equipment is to be installed.

INSTALLATION

Before installing this thermostat:

1. Read all of the installation instructions carefully.
2. Read the Owner's Manual carefully.
3. Ensure that this product is suitable for your application.
4. Ensure that wiring complies with all codes and ordinances.
5. Disconnect power to the control transformer to prevent electrical shock and damage to equipment.
6. Select an appropriate location to ensure an accurate temperature reading.

Location

When replacing an existing thermostat, install the RC-100BZ in the same location. If the existing location doesn't meet the following criteria, choose a new location. When choosing a location for the thermostat:

1. Ensure that the thermostat is mounted 5 feet above the floor and is at least 2 feet from an outdoor wall.
2. Ensure that the thermostat is located in an area where there is adequate air circulation.
3. Do not mount in the path of direct sunlight or of radiant heat generated by appliances.
4. Do not mount behind an outdoor wall, near a fireplace, or in the path of any air ducts.

Document Number 13100-61 / Rev A / May, 2007
Copyright © 1999-2007 Home Automation, Inc.
All Rights Reserved

Removing an existing thermostat

1. Disconnect the power to the control transformer.
2. Remove the cover to the existing thermostat.
3. Disconnect the wires going to each terminal on the thermostat. Label each wire with the letter or number at the terminal.
4. Remove the existing plate or base from the wall.

MOUNTING

When mounting the RC-100BZ, grasp the thermostat by the sides, avoiding the keys, and unsnap the base from the face.

Holding the base to the wall so that the word "TOP" is upright and facing you:

1. Mark the two mounting holes on the wall using a pencil.
2. Drill a hole using a 3/16" bit at each mounting hole marking.
3. Install the two wall anchors supplied.
4. Slide the system wires through the opening in the base.
5. Mount the base to the wall using the two #6 x 1/2" self-tapping screws supplied - See *Figure 1*.

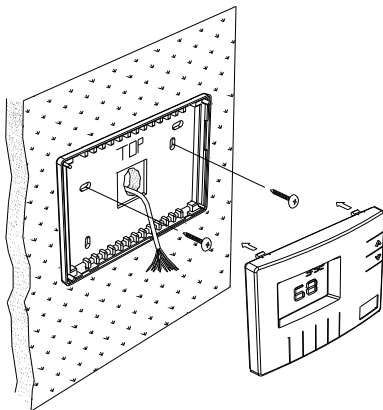

Figure 1

Connect each wire to the terminal strip on the thermostat base per the wiring diagram for your system application - See Figures 4 - 5.

Form the thermostat wiring so that the cable lies flat between the terminal strip and the center of the base.

Upon completion of wiring the thermostat, push all excess wiring into the hole in the wall. Plug the hole with the supplied insulating foam to ensure an accurate temperature reading by the thermostat.

Align the tabs of the thermostat face with the slots of the thermostat base. Gently push the thermostat face into the thermostat base locking it into place - See Figure 2.

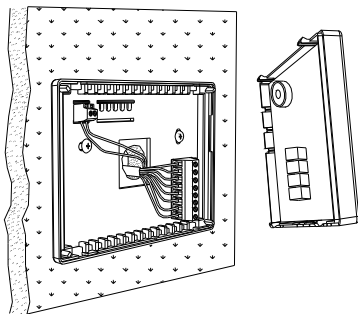

Figure 2

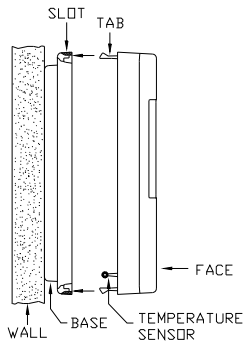

Figure 3

Note:

Be sure that the thermostat temperature sensor is standing up, and that it has not been damaged during installation - See Figure 3.

TYPICAL WIRING DIAGRAMS



CAUTION:

Be sure to disconnect the power to the control transformer before removing or installing thermostat.

Do not short compressor relay, fan relay, auxiliary heat relay, or reversing valve...even momentarily. This will blow a non-replaceable fuse.

Do not attempt to hook up to live circuits. An accidental connection to a component on the thermostat circuit board could cause damage to the thermostat.

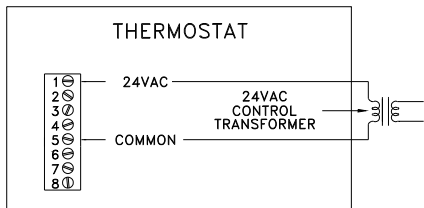

Figure 4 - Thermostat power-up for test or demonstration purposes

NOTES

- 1) As a convenience to the installer, the compressor start up protection delay can be canceled. To cancel the delay, press the Prog key 3 times, then press the Fan key 2 times.
- 2) "O" Terminal is energized for cooling
"B" Terminal is energized for heating

In most applications, the reversing valve is energized for cooling and should be connected to the "O" terminal. If the heat pump requires the reversing valve to be energized for heating, connect the reversing valve to the "B" terminal.
- 3) "X1" and "X2" are connected to a 24VAC Red LED, most often used to indicate a fault with the heat pump compressor.
- 4) The Emergency Heat Relay (E Terminal) and outdoor thermostats (usually accessories to a heat pump), are not used. The RC-100BZ automatically controls auxiliary heat efficiently.

The RC-100BZ requires at least 1 stage of auxiliary heat enabled at all times. If the heat pump is equipped with an outdoor thermostat, it should be removed from the auxiliary heat circuit, or reconfigured so that it can only disable 2nd and 3rd stage of auxiliary heat.

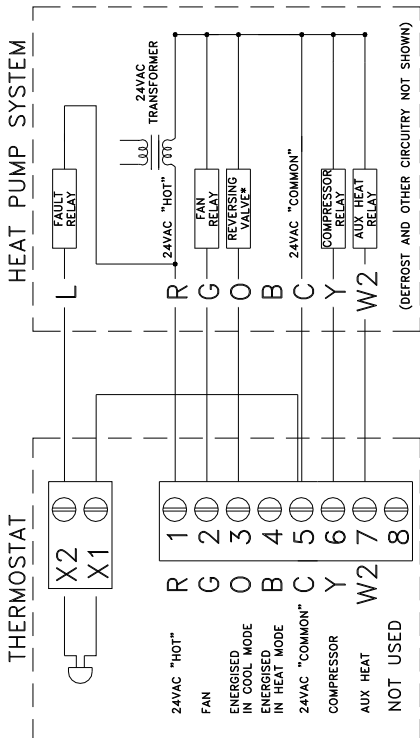

Figure 5

CONFIGURING THE BACKLIGHT ON THE RC-100BZ

The backlight on the RC-100BZ can be configured to one of three different modes: 1) on for 30 seconds when a key is pressed, 2) always on, or 3) always off.

- 1) To configure the display backlight to turn on when a key is pressed, then back off 30 seconds later, set the “JP2” (Select Backlight Mode) jumper to the “TIMED” position (between the top and middle pin on the connector) - See *Figure 6*.
- 2) To configure the display backlight to always be on, set the “JP2” (Select Backlight Mode) jumper to the “ON” position (between the middle and bottom pin on the connector) - See *Figure 6*.
- 3) To configure the display backlight to never come on (always off), remove the “JP2” (Select Backlight Mode) jumper from the connector - See *Figure 6*.

DISABLE KEYS

The keys on the thermostat can be disabled to prevent anyone from controlling the thermostat locally. To disable the keys, solder a wire jumper across “JP1” (two holes on the circuit board) - See *Figure 6*.

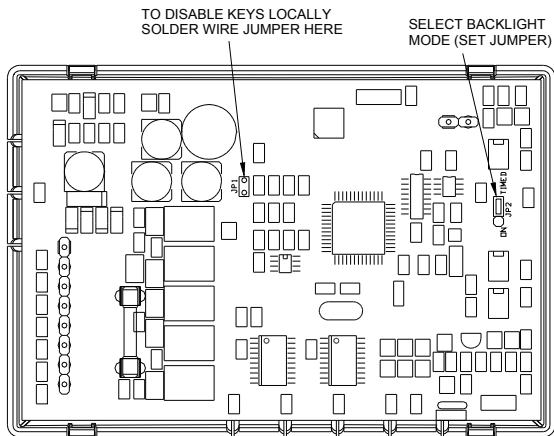

Figure 6

POWER UP

1. Double check wiring, be sure that there are no stray wires or wire strands at the connections.
2. Connect power to the transformer and system. The display will show all segments for about 5 seconds.
3. Press the Fan key. The fan should come on. Press the Fan key again. The fan should go off.
4. Set the Mode to "HEAT". Use the up arrow key to raise the desired temperature setting above the current temperature. Ensure that the heat pump comes on, in heating mode. After a few minutes, set the mode to "EM HEAT". The heat pump should stop and the auxiliary heating should come on. Set the mode to OFF. Ensure that both the heat pump and auxiliary heat go off.
5. Set the Mode to "COOL". Use the down arrow key to lower the desired temperature setting below the current temperature. Ensure that the heat pump comes on, in cooling mode. Set the mode to "OFF". Ensure that the cooling unit goes off.

If the thermostat or system does not perform as stated above, recheck all wiring - *See Troubleshooting Tips.*

INSTALLER SETUP

This section describes the items that the installer must setup as part of the thermostat installation. The Installer Setup mode is used to configure the general operating parameters of the thermostat.

When in Installer Setup mode:

1. The small digits on the top of the display are the item number.
2. The large blinking digits in the center of the display are the value of the item number.
3. Press the Prog (>) key to advance to the next item.
4. Press the Hold (<) key to return to the previous item.
5. Use the arrow keys (▲▼) to change the value of each item.
6. Do not set the values to anything other than the specified range for each item.
7. To exit Setup mode, press the Fan key.

The thermostat will automatically exit Setup mode after 20 seconds of no key activity.

To enter the Installer Setup mode, press the Prog key three times (day will flash), then press the Fan key.

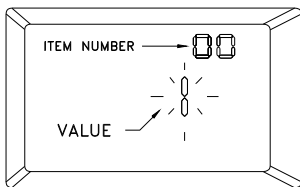

The word "default" indicates the initial setting when the thermostat is delivered from the factory.

00 Address

If you are using Communications Mode 0 or 1, and you are installing more than one thermostat, each must be set to a consecutive address, starting at 1. The default address setting is 1.

An address from 1- 127 may be selected.

01 Communications mode

The thermostat can communicate with remote systems in 4 different modes. These modes are:

- 0 300 baud, RS-232 mode (for use with personal computers)
- 1 100 baud, Z-Wave mode (OmniLT, Omni, Omni II, OmniPro, and OmniPro II systems)
- 8 PESH mode, (use with Model 1503 automation systems)
- 24 Day/Night mode (for use with remote setback switch)

The default setting is 1.

02 System options

The thermostat can be configured with the following system options:

WITH EEC	NO EEC*		
0	8	Auto changeover	no fan with heat
1	9	Auto changeover	fan on with heat
4	12	Manual changeover	no fan with heat
5	13	Manual changeover	fan on with heat

* Energy Efficient Control (EEC) of Auxiliary Heat: Select 0, 1, 4, and 5 to enable EEC, or 8, 9, 12, and 13 to disable EEC display. See Owner's Manual for description of EEC.

The default setting is 1.

In most heat pump installations, the auxiliary heat is electric resistance heat and the Energy Efficient Control (EEC) should be turned on (settings 0, 1, 4, and 5). If the heat pump is equipped with a more efficient auxiliary heat, such as hot water supplied by a gas water heater, you may want to turn EEC off (settings 8, 9, 12, and 13). The thermostat will act like a conventional 2 stage thermostat.

03 Display options

The thermostat can be configured to display the following attributes:

0	Celsius	am/pm time format	programmable
1	Fahrenheit	am/pm time format	programmable
2	Celsius	24-hour time format	programmable
3	Fahrenheit	24-hour time format	programmable
4	Celsius	am/pm time format	non-programmable
5	Fahrenheit	am/pm time format	non-programmable
6	Celsius	24-hour time format	non-programmable
7	Fahrenheit	24-hour time format	non-programmable

When communicating with an HAI controller, the thermostat should be configured as "non-programmable". To disable the clock and filter reminder displays, add "16" to each value.

The default setting is 1.

04 Calibration offset

This item is used to raise or lower the current temperature reading by 1 degree Fahrenheit or 1/2 degree Celsius. If this item is set to 30, no change will be made. Each digit below 30 will lower to temperature, and each digit above 30 will raise the temperature.

(1 = "- 29" to 59 = "+ 29" temperature units; 30 = No change)

The default setting is 30.

05 Cool setpoint limit

This item is used to limit the temperature setting in cool mode. The desired cool setting can never be set below this setting.

The default setting is 51.

06 Heat setpoint limit

This item is used to limit the temperature setting in heat mode. The desired heat setting can never be set above this setting.

The default setting is 91.

07 Not used

08 Not used

09 Not used

10 Not used

11 Cooling minimum on/off time (minutes)

This item is used to limit the on and off times of the cooling system. When the cooling system starts, it must remain on for the minimum time set by this item. When the cooling system turns off, it must remain off for a minimum time set by this item.

Setting	Cycles per hour (maximum)
5	6
6	5
7	4
8	3.7
10	3

The recommended setting is 8 minutes. A higher setting may be appropriate for buildings with low heat loss/gain.

The default setting is 8.

12 Heating minimum on/off time (minutes)

This item is the same as the "Cooling minimum on/off time", but for the heating system.

The default setting is 8.

13 Stage 2 Differential

This item specifies the temperature difference between stage 1 heating (the heat pump) and stage 2 heating (auxiliary heat). The default setting of 2 (degrees F) is recommended for all applications. In special cases a setting of 3 or 4 may be used when precise control of temperature is not as important as highest energy efficiency, however, the thermostat will not be able to maintain temperature within 1 degree of its setting under cold weather conditions. A setting of 1 or 0 is not recommended.

In this thermostat, the automatic anticipator will compensate for the temperature "droop" caused by the stage 2 differential under cold weather conditions.

14 Clock adjust

If the clock on the thermostat is running faster or slower than the actual time, you can have the thermostat automatically compensate up to 29 seconds per day. The thermostat will add or subtract the selected amount of time daily.

(1 = "- 29" to 59 = "+ 29" seconds per day; 30 = No change)

The default setting is 30.

Note: If an HAI automation system is being used, the controller system time is sent to the thermostat every minute. This adjustment will have no effect.

15 Filter reminder

The thermostat logs the amount of time the system fan has been running. When this setting reaches 0, the thermostat will display a reminder to replace the filter. The setting is the amount of days (24 hours of system operation) before this reminder is displayed.

Days - Counting down from 10 - 0

The filter reminder can be disabled by setting this item to 60.

16 System runtime (This week)

This item logs the amount of time (hours) that the heating and cooling system was in operation this week.

17 System runtime (Last week)

This item logs the amount of time (hours) that the heating and cooling system was in operation last week.

ANTICIPATION

RC-100BZ anticipation is performed electronically and is independent of the type and load of the components in the heating and cooling equipment. The RC-100BZ has electronic control based on proportional, integral, and derivative components and maintains temperature to within 1 degree F. of the setting. Anticipation is not adjustable on the RC-100BZ.

OWNER'S MANUAL

Following Installer Setup, check the option boxes () in the Owner's Manual according to the configuration of the thermostat.

QUICK-REFERENCE SETUP GUIDE

This table displays each Installer Setup item with its default setting. The column labeled "CURRENT" can be used to write down the current settings if any changes are made to the default settings.

Item Number	Description	Default	Current
00	Address	1	
01	Communication mode	1	
02	System options	1	
03	Display options	1	
04	Calibration offset	30	
05	Cool setpoint limit	51	
06	Heat setpoint limit	91	
07	Not used	-	
08	Not used	-	
09	Not used	-	
10	Not used	-	
11	Cooling minimum on/off time	8	
12	Heating minimum on/off time	8	
13	Stage 2 Differential	2	
14	Clock adjust	30	
15	Filter reminder	10	
16	System runtime (This week)	-	
17	System runtime (Last week)	-	

WIRELESS COMMUNICATIONS WITH HAI CONTROLLER

This thermostat has been preprogrammed with energy saving settings recommended under the EPA Energy Star program. When used with remote systems, HAI recommends that the thermostat be configured as "non-programmable" (See Setup Item 03 - "Display Options").

HAI AUTOMATION SYSTEMS

The thermostat can communicate with an HAI automation system over a Z-Wave network. The controller can send commands to the thermostat to change mode, cool setting, heat setting, status of fan and hold, and other items.

ADDING A THERMOSTAT TO THE Z-WAVE NETWORK

When prompted by Z-Wave primary or inclusion controller to include the thermostat to the network, press and release the 'Hold' button on the thermostat. This will include the thermostat on the Z-Wave network.

REMOVING A THERMOSTAT FROM THE Z-WAVE NETWORK

When prompted by Z-Wave primary or inclusion controller to exclude the thermostat from the network, press and release the 'Hold' button on the thermostat. This will exclude the thermostat from the Z-Wave network.

The thermostat supports the following command classes:

COMMAND_CLASS_THERMOSTAT_MODE
COMMAND_CLASS_THERMOSTAT_SETPOINT
COMMAND_CLASS_THERMOSTAT_FAN_MODE
COMMAND_CLASS_THERMOSTAT_FAN_STATE
COMMAND_CLASS_THERMOSTAT_OPERATING_STATE
COMMAND_CLASS_SENSOR_MULTILEVEL
COMMAND_CLASS_ASSOCIATION
COMMAND_CLASS_CONFIGURATION
COMMAND_CLASS_VERSION
COMMAND_CLASS_MANUFACTURER_SPECIFIC
COMMAND_CLASS_SWITCH_BINARY
COMMAND_CLASS_CLOCK

COMMAND_CLASS_THERMOSTAT_MODE

Upon power up, allow 10 seconds for the RC-100BZ thermostat to initialize. After 10 seconds, a controller can set the mode, get the current mode, and get the modes supported by the thermostat.

COMMAND_CLASS_THERMOSTAT_SETPOINT

Upon power up, allow 10 seconds for the RC-100BZ thermostat to initialize. After 10 seconds, a controller can change setpoints, get current setpoints, and request the setpoints that are supported by thermostat.

COMMAND_CLASS_SENSOR_MULTILEVEL

The RC-100BZ thermostat uses this command class to report the actual temperature.

COMMAND_CLASS_ASSOCIATION

Upon power up, allow 10 seconds for the RC-100BZ thermostat to initialize. After 10 seconds, a controller can issue an Association Set, Remove, or Get command. The thermostat must be associated with a controller to provide feedback.

COMMAND_CLASS_CONFIGURATION

Upon power up, allow 10 seconds for the RC-100BZ thermostat to initialize. After 10 seconds, a controller can change individual register settings for the outdoor temperature. The Parameter Number is 67. The size of the data is a 1 byte value. The Value is the temperature to which the register is set.

COMMAND_CLASS_THERMOSTAT_FAN_MODE

Upon power up, allow 10 seconds for the RC-100BZ thermostat to initialize. After 10 seconds, a controller can set the fan mode, get the current fan mode, and get the fan modes supported by the thermostat.

COMMAND_CLASS_THERMOSTAT_FAN_STATE

Upon power up, allow 10 seconds for the RC-100BZ thermostat to initialize. After 10 seconds, a controller can request the state of the fan.

COMMAND_CLASS_THERMOSTAT_OPERATING_STATE

Upon power up, allow 10 seconds for the RC-100BZ thermostat to initialize. After 10 seconds, a controller can request the Operating State report.

COMMAND_CLASS_VERSION

Upon power up, allow 10 seconds for the RC-100BZ thermostat to initialize. After 10 seconds, a controller can request a Version Report. This report includes information about the library type, protocol, version, and application version from the device.

COMMAND_CLASS_MANUFACTURER_SPECIFIC

Upon power up, allow 10 seconds for the RC-100BZ thermostat to initialize. After 10 seconds, a controller can request a Manufacturer Specific Info Report. This report will return the Manufacturer ID, Product Type, and Product ID.

COMMAND_CLASS_SWITCH_BINARY

Upon power up, allow 10 seconds for the RC-100BZ thermostat to initialize. After 10 seconds, a controller can turn on the Hold feature by sending a Binary Switch On command and turn off the Hold feature by sending a Binary Switch Off command.

COMMAND_CLASS_CLOCK

Upon power up, allow 10 seconds for the RC-100BZ thermostat to initialize. After 10 seconds, a controller can set the time of the internal clock

INTEROPERABILITY WITH Z-WAVE™ DEVICES

A Z-Wave™ network can integrate devices of various classes, and these devices can be made by different manufacturers. The RC-100BZ thermostat can be incorporated into existing Z-Wave™ networks. All listening Z-Wave nodes act as repeaters regardless of vendor.

FCC NOTICE

Note: This equipment has been tested and found to comply with the limits for a Class B digital device, pursuant to part 15 of the FCC Rules. These limits are designed to provide reasonable protection against harmful interference in a residential installation. This equipment generates, uses, and can radiate radio frequency energy and, if not installed and used in accordance with the instructions may cause harmful interference to radio communications. However, there is no guarantee that interference will not occur in a particular installation. If this equipment does cause harmful interference to radio or television reception, which can be determined by turning the equipment off and on, the user is encouraged to try to correct the interference by one or more of the following measures:

- Increase the separation between the equipment and receiver.
- Consult the dealer or an experienced radio/TV technician for help.

TROUBLESHOOTING TIPS

SYMPTOM	ACTION TO TAKE
Thermostat Dead	1. Check power to the thermostat
	2. Check wiring diagrams
	3. Check thermostat temperature sensor
Thermostat will not operate with a damaged temperature sensor	
SYMPTOM	ACTION TO TAKE
Fan, Heat, Or Cool Inoperative	1. Check for break in G, W, or Y wire
	2. Allow minimum off time to pass
	3. Check system options for correct settings
	4. Remote system is overriding thermostat
"REMOTE" is displayed when system is overriding thermostat.	
SYMPTOM	ACTION TO TAKE
Can't Adjust Temperature	1. Mode is Off (Select Heat, Cool, or Auto)
	2. Check if thermostat keys are disabled
To enable thermostat keys for test, remove jumper	
SYMPTOM	ACTION TO TAKE
Control By Remote System Not Working	1. Check Node ID
	2. Check communications mode setting
	3. Check setup of the remote system
Ensure that all setup items for the thermostat and the remote system are set to the proper configurations for communication	
SYMPTOM	ACTION TO TAKE
Temperature Reading Incorrect	1. Allow 30 minutes for thermostat to adjust to room temperature
	2. Adjust calibration offset
	3. Change setup option to display °F or °C
After installation, allow the thermostat up to 30 minutes for an accurate temperature reading	
SYMPTOM	ACTION TO TAKE
Display Problem	1. Disconnect power to the thermostat. Reconnect, then observe display self-test
For a 5 second period after power is reconnected, all segments of the display should light indicating all thermostat functions	

HEAT PUMP CROSS REFERENCE GUIDE

RC-100BZ	R (1)	G (2)	O (3)	B (4)	C (5)	Y (6)	W2 (7)	X2
CARRIER, PAYNE DAY&NIGHT	R	G	O		C	Y1	W2	L
TRANE	R	G	O		BLUE	Y	W	C
COLEMAN 3000 SERIES	R	G	O	B	X	Y	W2	L
COMFORTMAKER CYC SERIES	R	G	O		C	Y	W1	
GOETTL HP	R	G		B	X	Y	W2	
HEIL QUAKER 867, PH50	R	G	O		C	Y	W1 W2	
LENNOX * HP19, HP20	V VR	F	R		X	M	Y	L
LENNOX CB19	R	G	O		C	Y	W1	L
RHEEM / RUDD PGB, PFA, PCB	R	G	O		X	Y	W2	L
WEATHERTRON	R	G	O		B	Y	W-U	
YORK - EICS, E1FB, E1FH	R	G	O		B	Y	W	X

RC-100BZ TERMINAL DESCRIPTIONS

R	(1):	24VAC "HOT"
G	(2):	FAN
O	(3):	REV VALVE (COOLING)
B	(4):	REV VALVE (HEATING)
C	(5):	24VAC COMMON
Y	(6):	COMPRESSOR
W2	(7):	AUXILIARY HEAT
	(8):	NOT USED

X2 FAULT LED

Note:

X1 is jumped to C terminal in the RC-100BZ, if X2 is in use.