



Operation & Maintenance

2100 Series Fire Rescue Saw

Model CE2165RS • Model CE2171RS

CUTTERS EDGE[®]

MULTI-CUT[®]
FIRE RESCUE SAWS



Your Cutters Edge Shipping Carton Should Include the Following:



- (A) Cutters Edge Fire Rescue Saw
- (B) Warranty card
- (C) Cutters Edge Fire Rescue Saw Operations Manual
- (D) Chainsaw Operators Manual
- (E) Chainsaw Safety Manual
- (F) Illustrated Parts List
- (G) Cutters Edge Bar & Chain Oil
- (H) 8 oz. Bottle Cutters Edge 2-Cycle Oil
- (I) Allen Wrenches
- (J) Filter Oil
- (K) Grease Gun
- (L) Grease Packet

Information in this manual is for the following Cutters Edge Fire Rescue Saw Model Numbers:

CE2165RS-12", CE2165RS-16", CE2165RS-20", CE2165RS/D6, CE2165RS/D8, CE2171RS-12", CE2171RS-16", CE2171RS-20", CE2171RS/D6, CE2171RS/D8.

Copyright 2001 Edge Industries, Inc • All rights reserved. No part of this manual may be reproduced or transmitted in any form or by any means, electronic, mechanical, photocopying, recording or otherwise, without prior written consent of the publisher. For information, contact Edge Industries, Inc.

Notice of Liability • The information contained in this manual is distributed on an "As Is" basis without warranty. Edge Industries shall have no liability to any person or entity with respect to any liability, loss or damage caused or alleged to be caused directly or indirectly by the instructions contained in this manual. The information in this manual is subject to change without notice.



Please take note of the **WARNINGS HIGHLIGHTED IN THIS MANUAL** and the warning labels attached to the various parts of the saw and its accessories. Read these warnings and heed their advice. Failure to do so could result in injury to you and/or damage to the saw. Any warranties provided by the manufacturer will not cover abuse, neglect or mishandling of the saw.

UNDER NO CIRCUMSTANCES MAY THE DESIGN OF THE MACHINE BE MODIFIED WITHOUT THE PERMISSION OF THE MANUFACTURER. Always use genuine accessories. Non-authorized modifications and/or accessories can result in serious personal injury or the death of the operator or others. Your warranty does not cover damage or liability by the use of non-authorized accessories or replacement parts.

CUTTERS EDGE®, MULTI-CUT®, FIRE RESCUE SAW®, BULLET® CHAIN, GUARD/DEPTH GAUGE® – Patent Numbers:

UNITED STATES - 5,156,156, 5,056,395	FRANCE - 0439085	ITALY - 0439085	AUSTRALIA - 627393	NORWAY - 176168	AUSTRIA - 0439085
RUSSIAN FED - 2021885	BRAZIL - PI 9100284-2	SPAIN - 2055928	CANADA - 2034,798	SWEDEN - 0439085	
CZECH REPUBLIC - 279.962	SWITZERLAND - 0439085	FINLAND - 910356	UNITED KINGDOM - 0439085		

CUTTERS EDGE®

Operation & Maintenance

Table of Contents

Introduction	3
Kickback Warning	3
Visual Description	4

Part One

Familiarization of Operation	5
Installing Bar and Chain	6
Starting	9
Installing Guard Depth Gauge	12

Part Two

Maintenance	15
Specifications	20/21
Warranty	22

Introduction

VENTILATION: Cutters Edge Fire Rescue Saws are designed and built exclusively *for use by trained firefighters*. Although Cutters Edge Fire Rescue Saws are essentially modified chainsaws their use and applications differ substantially. This manual is provided to assist you in learning the safe and proper set-up, start-up and maintenance of your new Cutters Edge Fire Rescue Saw. However, you should not attempt to use this tool without knowledge of the safe and proper applications of power saws in fighting fires. This manual is in no way intended to replace the basic chainsaw manual; rather it should be used as a supplemental manual dealing with the specific applications of this specialized firefighting tool. Nor are the guidelines for operational procedures described herein intended to contradict the standard operating procedures (SOP) of your individual fire department.

There are a number of excellent training publications available about the principles and techniques of ventilation. Cutters Edge recommends the book "**FIRE RESCUE METHODS AND TECHNIQUES**", by Los Angeles City Fire Department Battalion Chief (Ret.), John Mittendorf

The purpose of ventilation is to establish a safer interior environment through planned and systematic removal of heat, smoke, and toxic gases and their replacement with fresh air. Ventilation is an offensive technique that, when accomplished early and effectively, can speed tactical operations and provide a safer environment for firefighters.

As fire develops within a structure, several conditions result. First, the temperature and toxicity of the atmosphere increase rapidly. Then radiated and convected heat result in flashover and the subsequent rapid spread of fire throughout the structure. Without ventilation the fire will develop a super-heated, oxygen deficient and fuel-rich environment ripe for backdraft.

Firefighters can minimize these dangerous conditions with proper ventilation techniques and proper tools. Knowledge, training and Cutters Edge Fire Rescue Saws are the proper tools.

RESCUE: With the development of the BULLET® CHAIN, applications for your CUTTERS EDGE® FIRE RESCUE SAW have increased dramatically compared to conventional chain saws and rotary saws.

Your Fire Rescue Saw can be used for many operations, including: Ventilation, Forcible Entry, Storm Damage, Rescue, Crash Rescue and many conventional rotary and chain saw applications.

While chain wear and damage may be accelerated when cutting materials other than wood, your BULLET® CHAIN equipped saw is capable of cutting most building materials, including roofing nails, joist hangers, nailing plates, flashing, light gauge sheet metal and some lightweight concretes. It is capable of cutting automotive sheet metal, automotive glass, hurricane glass, bulletproof glass, plastics, fiberglass, and many other composite materials. It can also cut aircraft skin, cockpit and aircraft windows, including some aircraft structural materials*.

There are, of course, limitations but your CUTTERS EDGE FIRE RESCUE SAW with BULLET® CHAIN will cut a wide variety of materials under the most severe fire ground and rescue scene conditions.

This manual will familiarize you with your new Fire Rescue Saw and take you through the proper procedures for installing the guide bar and BULLET® CHAIN and Guard/Depth Gauge®. It will also show you how to clean and maintain the saw after use.

Before attempting to assemble or use your saw, we strongly suggest that you read this manual completely. Then carefully follow the instructions in this manual as you proceed to prepare your Cutters Edge Fire Rescue Saw for use.

** When materials other than wood are cut, increased wear and damage should be anticipated. The possibility of chain breakage also increases. All materials listed have been successfully cut under controlled conditions or during actual fireground and rescue incidents. However, quantity, composition of specific materials, operator experience, existing conditions and unknown factors can adversely affect the outcome.*



Beware of Kickback!

There are two types of kickback that can be encountered with the improper use of a chainsaw.

ROTATIONAL KICKBACK is the violent reaction which occurs when the chain at the upper section of the nose is suddenly stopped, thereby dangerously driving the bar nose in an upward arc toward the operator.

WARNING!

LINEAR KICKBACK is a push reaction, which can occur when the saw is buried in the cut and the cut closes, pinching the chain along the top rails of the bar, pushing the saw into the operator.

CUTTERS EDGE FIRE RESCUE SAWS WITH BULLET® CHAINS HAVE THE LOWEST KICKBACK POTENTIAL AND HIGHEST LEVEL OF SAFETY AVAILABLE.

The Cutters Edge Fire Rescue Saw, equipped with the BULLET® CHAIN was tested for kickback by SMP, The Swedish Testing Institute. Because of the unique cutting action of the BULLET® CHAIN, the test results on the CUTTERS EDGE FIRE RESCUE SAW showed it to have extremely low kickback, in fact, the lowest kickback potential of any chainsaw style saw.

The Cutters Edge Fire Rescue Saw

Cutters Edge Fire Rescue Saws are shipped fully assembled. The 12", 16" and 20" RS Models come with a protective scabbard covering the BULLET® CHAIN. The GUARD/DEPTH GAUGE® on the D6 and D8 Models covers the BULLET® CHAIN so a scabbard is not included on these models.

Familiarize yourself with various components and parts of the saw.

1. Chain Brake Handle
2. Oil Tank Cap
3. Starter Handle
4. Sparkplug/Carburetor Access Latch
5. Fuel Tank Cap
6. Throttle Trigger
7. Throttle Trigger Safety Lock
8. Pre-Filter
9. Main Filter Element
10. On/Off Momentary Contact Switch

11. Scrench Tool
12. Scrench Tool Holder
13. Guard Deflector
14. Choke Control
15. Full Wrap Handle
16. Chain Tension Adjustment Screw
17. Clutch Cover/Bar Mount Nuts
18. Compression Release

CUTTERS EDGE
 MULTI-CUT®
 FIRE RESCUE SAWS

Part One: FAMILIARIZATION OF OPERATION

THE CHAIN BRAKE

The chain brake is designed to stop the rotation of the chain in less than one-twentieth of a second. If kickback should occur, the violent reverse action will actuate the inertia chain brake (same principle as a car seatbelt) or drive the chain brake handle back into the operator’s hand, engaging the chain brake and stopping the movement of the chain.

The chain brake has three positions:

Fig. 1. Center- operating position, chain brake disengaged. (Normal cutting position).

During operation, the brake is in the *neutral* or *center position* (Fig.1). This allows the chain to turn freely.

Fig. 2. Forward Position - chain brake engaged

When engaged, the chain brake handle is in the *fully forward* position (Fig. 2). *In this position the chain will not turn.*

Fig. 3. Back position - to disengage chain brake

To disengage the chain brake, pull the chain brake handle back completely to the saw’s top handle (Fig. 3).

It is important that the chain brake handle comes into full contact with the saw’s handle. Any obstructions, such as your hand, will prevent disengagement of the chain brake.

Once you have pulled the chain brake handle back completely, let go and it will snap back to the center operating position. (See Fig. 1)

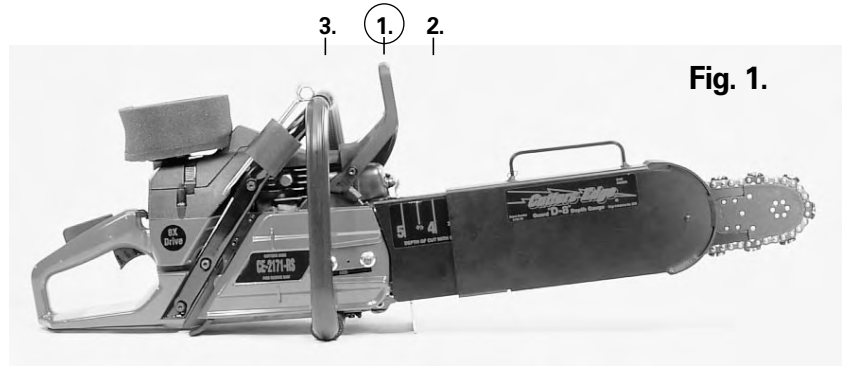

Fig. 1.

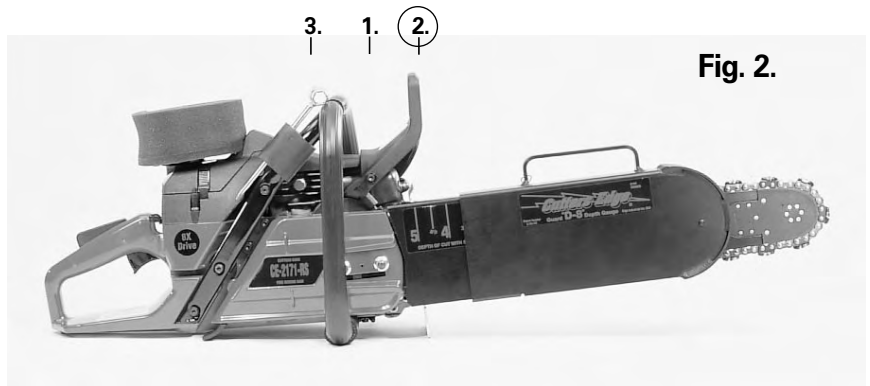

Fig. 2.

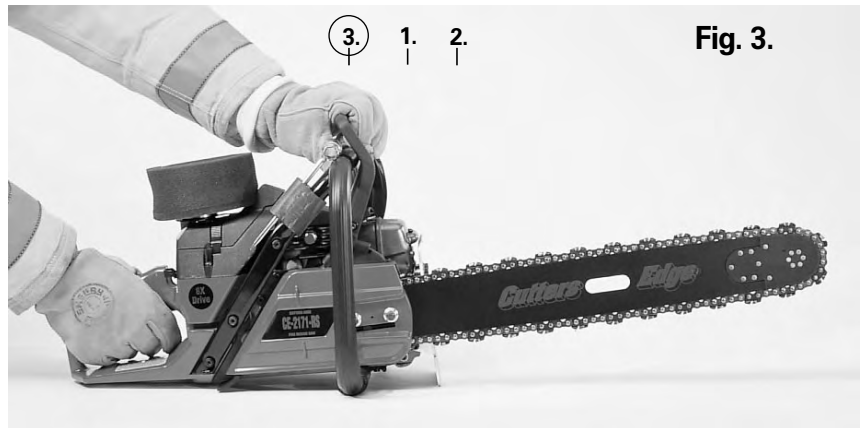

Fig. 3.

REMOVAL AND REINSTALLATION OF THE GUIDE BAR AND CHAIN

REMOVE CLUTCH COVER

Using the screwdriver loosen the two clutch cover bar mount nuts shown in Fig. 4.

Remove Chain and Guide Bar from the saw.

TO REINSTALL CHAIN AND GUIDE BAR

To mount the guide bar, slide the guide bar onto the two bar mount studs. See Fig. 5.

To install the chain, align the chain so that the cutters are pointing toward the tip of the guide bar as they lay on the top of the bar. Slip the chain onto the clutch sprocket rim (Fig. 5). Then slip the chain into the groove of the guide bar, again verifying that the top cutters point toward the tip of the guide bar. Pull the chain around the bar to be sure the drive links are properly seated in the drive sprocket.

Mount Clutch Cover onto the two bar mount studs (Fig. 5) Using the screwdriver, turn the tensioning adjustment screw to align the chain adjuster pin with the hole in the guide bar. (Figs. 6 and 7).

When the adjuster pin is aligned with the hole in the guide bar push the clutch cover to set it fully against the saw. Install the two bar nuts finger tight.

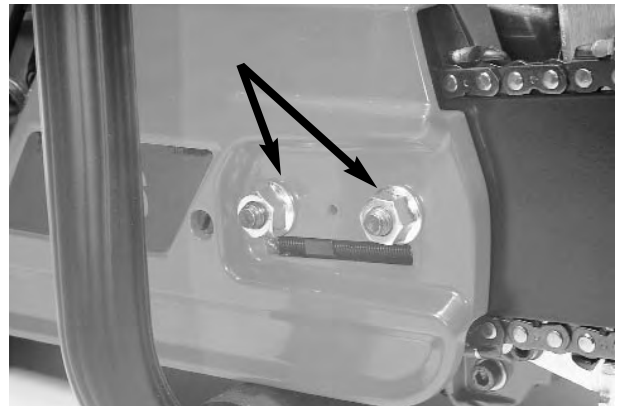

Fig. 4. Clutch Cover Bar Mount Nuts

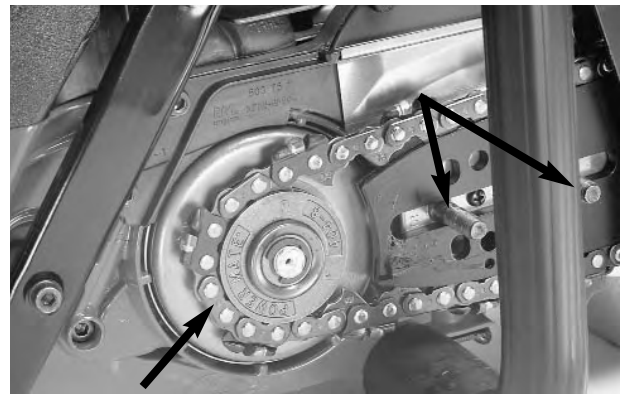

Fig. 5. Bar Mount Studs and Clutch Sprocket

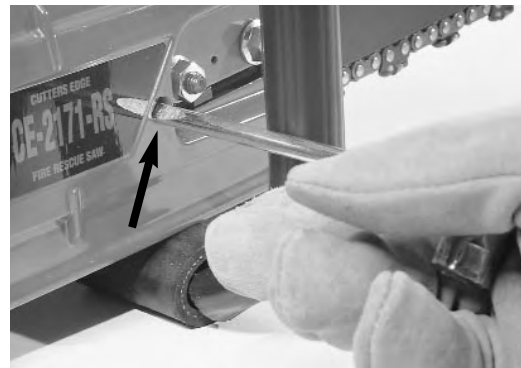

Fig. 6. Tensioning Adjustment Screw

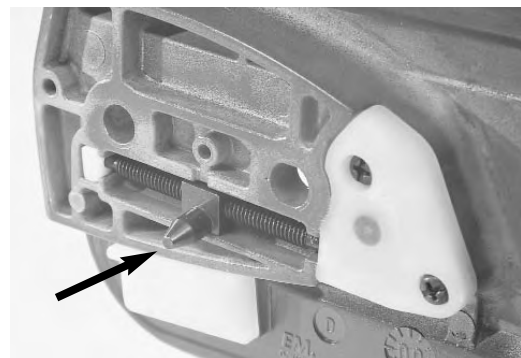

Fig. 7. Chain Adjustment Pin

ADJUSTING THE CHAIN TENSION

Wearing gloves or using a rag to protect your hand, pull up on the tip of the guide bar. While holding up the guide bar tip, tighten the chain tension adjustment screw (Fig. 6 on page 6) by turning it clockwise. While still holding up the bar tip, tighten the two clutch cover nuts (Fig. 8). Holding up the tip of the bar takes out any slack between the bar mounting slot and the two mounting studs. This will eliminate any upward movement of the guide bar when cutting pressure is applied at the bottom of the bar. Any such upward movement of the bar could cause the chain to loosen.

Proper chain tension is a key factor in reducing carbide breakage and increasing guide bar life. **Proper chain tension has the chain as tight as possible without restricting chain movement. (Fig. 8)**

At proper tension, the chain should move along the bar freely. You should feel only the resistance of the sprocket and clutch drum turning. If the chain does not move smoothly (catches or requires excessive force to move) it is too tight. At proper tension, the chain is in full contact with the bar along the bottom rails, (Fig.8) there is no "sag". (Fig. 9).

At the midpoint along the bottom rails, when pulling down on the chain, you should be able to pull the chain away from the rails, to the distance where the point of the drive link is "just clearing the rail" (Fig. 10) and snaps back into place when you release it.



Fig. 8. Tighten two clutch cover nuts so chain is at proper tension



Fig. 9 "Sag" chain is too loose



Fig. 10. Proper chain tension - while pulling chain down, drive links just clearing the rail

FILLING THE TANKS

Lay the saw on its side and remove the fuel tank cap (Fig. 11). Fill with a fresh mixture of high octane leaded or unleaded gasoline and Cutters Edge Synthetic 2-Cycle Oil or a high quality two-cycle oil. Replace the fuel cap.



WARNING!

Please note that each time you fill up or top off the fuel tank, always top off the bar and chain oil tank. The fuel tank and the bar and chain oil tank are sized so that the saw will always run out of fuel before it runs out of bar and chain oil, eliminating the possibility of running the chain without proper lubrication.

IMPORTANT!

- *Fuel/Oil Mix ratio using Cutters Edge Oil ... 100:1*
- *Using synthetic oils mix ... follow oil manufacturers recommendation*
- *Using any petroleum based oil ... 50:1.*

Next, remove the bar and chain oil tank cap (Fig. 11) and fill the tank with bar and chain oil. Replace the cap.

You do not need special detergent oils; as the chain reaches high enough temperatures to prevent the buildup of tars on the chain. We recommend the use of Cutters Edge Bar & Chain Oil for its excellent lubricating and anti-sling properties. This oil has been developed to provide high flash and fire points for optimum performance during harsh fire-ground applications, with high flow properties for use, even in extreme cold temperatures. This anti-rust, anti-wear formula is recommended for use on all Fire Rescue saws and on conventional chainsaws.

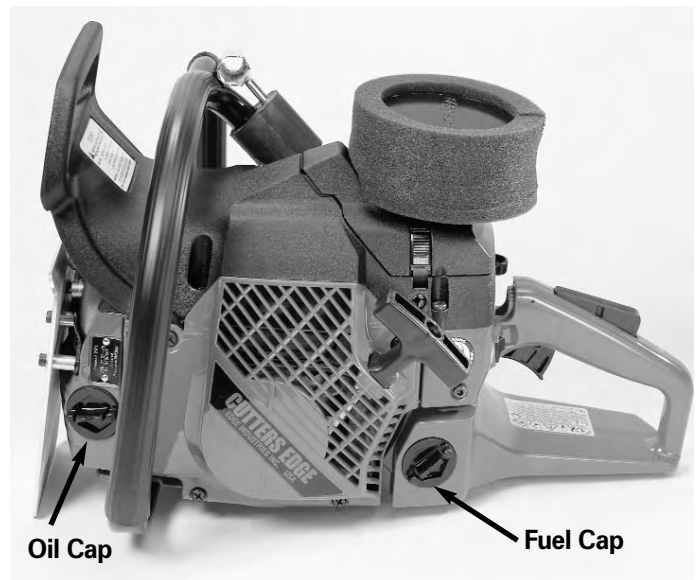

Fig. 11. Fuel Cap and Oil Cap



WARNING!

Do not mix the bar and chain oil with diesel fuel, kerosene or any solvents as this actually reduces its lubricating properties, increases its flash point and does not reduce tar buildup on the chain.



WARNING!

IF POSSIBLE AVOID USING GASOHOL OR ALCOHOL BLENDED FUELS

THE MOMENTARY CONTACT SWITCH

Before starting the saw, you should know how to stop it. The Cutters Edge Fire Rescue Saw is equipped with a momentary contact switch that is always in the “on” position (Fig 12). To stop the saw, push and hold the momentary contact switch to the right. This kills the saw. When released, the switch will snap back into the “on” position automatically.

STARTING THE SAW

IMPORTANT!

Before starting the saw, it is important to note that you should not run the saw at full throttle until after breaking in the engine.

To start the saw, place it on the ground. Grip the top handle firmly and step on the outer edge of the back handle. (Fig.13)

IMPORTANT! CHECK THE CHAIN BRAKE BEFORE STARTING

Do not start the saw with the chain brake engaged. Be sure the chain brake is disengaged by pulling back the chain brake handle until it contacts the front of the full wrap handle. (See Fig. 3 on page 5).

COLD START

- (1) Pull out the choke knob*. This automatically locks the throttle trigger and the carburetor into their optimum positions for starting. *If you do not touch the throttle during starting, there is no possibility of flooding.*
- (2) Grasp the starter handle and pull sharply upward a few times until the engine catches.
- (3) Push the choke in.
- (4) Pull the starter handle again. The engine will start.
- (5) Let saw run at fast idle for 5 seconds.
- (6) Quickly squeeze and release the throttle trigger to set the idle.

* We recommend storing the saw with the choke knob pulled out.



Fig. 12. Momentary Contact Switch



Fig. 13. Proper starting position

WARM START

(Engine still warm from previous use)
 (1) Pull starter handle until saw starts.

NOTE

You must depress the safety lock on top of the handle (Figs. 14 & 15) to be able to engage the trigger. The trigger will not function without depressing the safety lock.

RUNNING-IN THE CHAIN

Running-in the chain stretches and fully lubricates the chain for optimum longevity and performance.

Start the saw and run it at three-quarter speed for approximately 10 minutes or until the bar and chain begin to smoke.

Now turn off the saw. The chain has reached its operating temperature. You will notice the chain now sags from the bar. (Fig. 16) Before readjusting, allow the chain to cool down for three to five minutes, or until it is cool enough to touch.

Once it is cool enough to handle, readjust the chain to the proper tension. See Page 7 for chain tension adjustment.

NOTE

We recommend you repeat this entire chain running-in procedure at least once more.



Fig. 14 Safety Lock



Fig. 15 Depressing the Safety Lock



Fig. 16 The chain will sag when hot

BREAKING IN THE ENGINE



WARNING!

Proper breaking in of the engine is a crucial step in the set-up of your saw. This procedure allows the cylinder to coat with oil and seat the piston ring properly. If you skip this procedure and run the saw at full throttle, severe damage to the engine can occur.

IMPORTANT: OIL TANK MUST BE FULL

Although the chain will not turn at idle and no bar and chain oil will be pumped, this break in procedure must be performed with the bar and chain installed and the bar and chain oil tank filled. Also, be sure the chain brake remains disengaged throughout this procedure.

To perform the initial engine break in, start the saw and let it idle through a complete tank of fuel. It is advisable to briefly operate the saw at 3/4 throttle periodically during this procedure to clear out unburned fuel.



WARNING!

During break-in do not run the engine at full throttle for more than 2 seconds or engine damage may occur.

This is an initial engine break in only. The engine will not be completely broken in until it has been operated through several tanks of fuel.

NOTE

Cutting clean wood; plywood, trees, etc. (no nails or roofing material) during the chain stretching procedure and/ or engine break in procedure will decrease the required time and result in a more complete break in. If you do cut clean wood during these procedures make sure you do not exceed 3/4 throttle (75% maximum engine speed).

CUTTERS EDGE® D-6 & D-8 TOOL-LESS GUARD/DEPTH GAUGE®

Installation, Operation & Maintenance

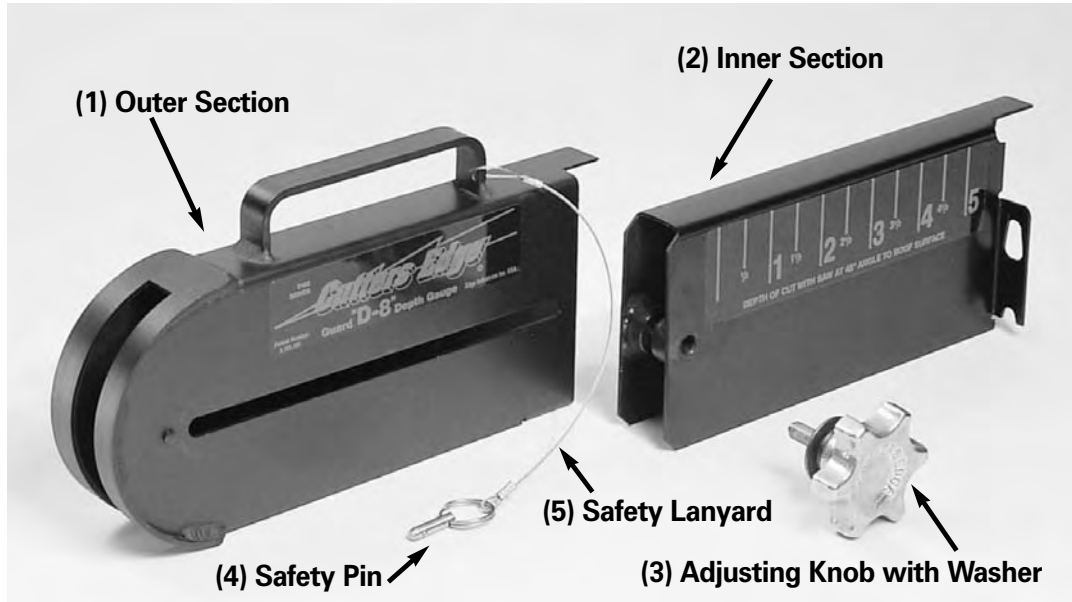

Fig. 17.

Guard/Depth Gauge Parts

- (1) Outer Section
- (2) Inner Section
- (3) Adjusting Knob with Washer
- (4) Safety Pin
- (5) Safety Lanyard

CUTTERS EDGE® Tool-less D-8 & D-6 Guard/Depth Gauge®

The Cutters Edge Tool-less GUARD/DEPTH GAUGE® has been designed, engineered and carefully tested to provide increased safety and efficiency in firefighting and rescue applications.

In its fully extended position, the Guard/Depth Gauge completely covers the guide bar and cutting chain, protecting the operator from accidental contact with the chain. Even when retracted and set for specific depths of cut, the Guard/Depth Gauge covers all but the chain exposed for cutting.

The Guard/Depth Gauge allows you to set a specific depth of cut to prevent cutting any deeper than is absolutely necessary. This prevents possible

weakening of the roof structure and prevents exposure to hidden hazards like electrical wiring and pipes.

These Guard/Depth Gauge features are designed to provide the operator with increased confidence resulting in faster cuts with less worry. The operator can concentrate more on cutting position, fire behavior and the surrounding fire rescue environment.

Of course, as with any tool, it is only as safe as its operator. You must be careful to take all necessary safety precautions and to follow all safe operating procedures.

These instructions are intended to help you install and safely utilize the Cutters Edge Tool-Less Guard/Depth Gauge®, whether you are installing it on a new Cutters Edge Saw or upgrading an older Cutters Edge Saw. Take the time to read these instructions carefully. Familiarize yourself with the parts and components of the Tool-Less Guard/Depth Gauge®

Installing The Tool-Less Guard/Depth Gauge®

The Inner Section

Place the inner section over the chain and guide bar, sliding the mounting slots (A) onto the locking key (B) and mounting bolt (C) on the guard deflector. Push down to lock in place. (Fig. 18 & 19).

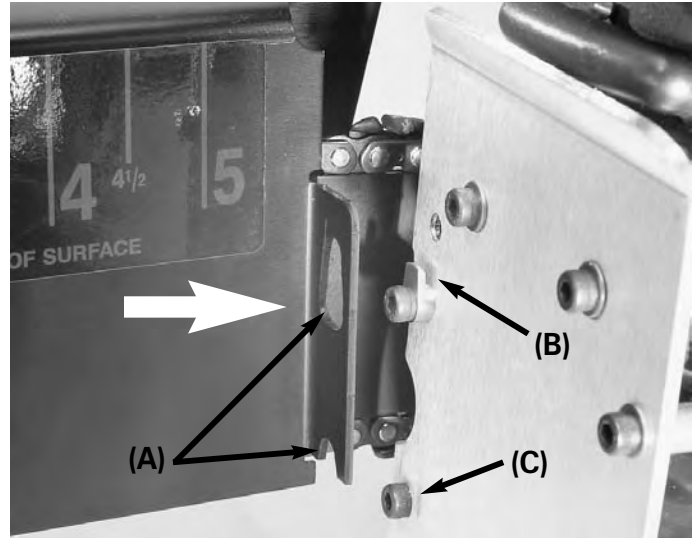

Fig. 18. Slide mounting slots (A) onto locking key (B) and bolt (C)

The Guard/Depth Gauge Outer Section With Lanyard and Quick Release Safety Pin (Fig. 20)

Place the outer section onto the guide bar and slide it over the inner section. Insert the safety pin into the hole on the guard deflector, above the locking key. Insert the Adjustment knob shaft through the slot in the outer section and screw into the threaded hole.

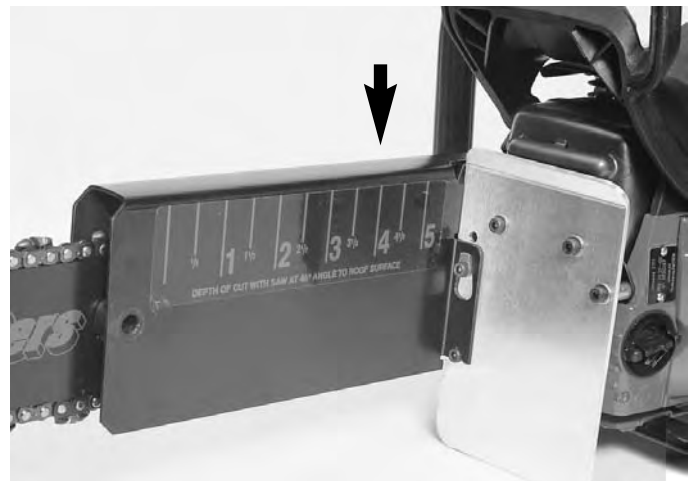

Fig. 19 . Push down to lock in place

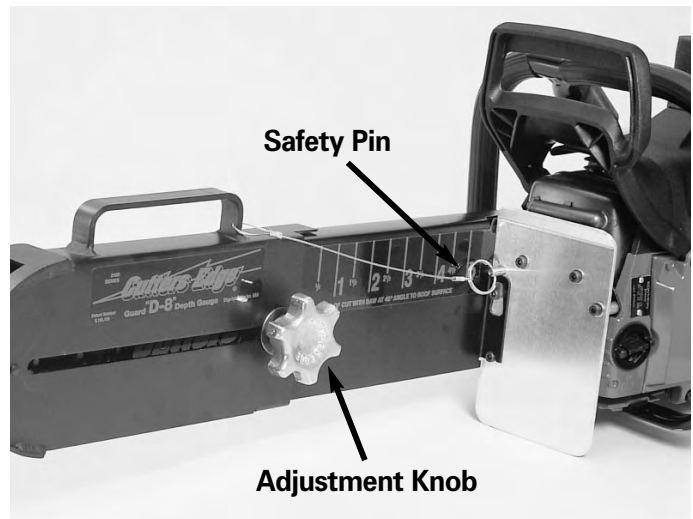

Fig. 20 . Completed Installation

Operation of the Tool-Less Guard/Depth Gauge®

(Fig. 21) To adjust the Guard/Depth Gauge, if the saw is running, first set the saw's chain brake. Loosen the adjusting knob and slide the outer section to the desired setting. Retighten the adjusting knob and release the chain brake.



Fig. 21. Set to the desired depth of cut.

IMPORTANT: *In its fully extended position, the Guard/Depth Gauge completely covers the cutting chain. Thus, you can now start the saw on the ground and carry it up to the roof or to your cutting position while it is running.*

This eliminates the need to restart the saw after you are in position and assures a warmed up, operational saw.

Cutting Deeper than the Guard/Depth Gauge® Setting

Even with the Guard/Depth Gauge set to a pre-determined depth you can increase the depth of your cut without changing the setting by increasing the angle of the saw in relation to the roof surface. While cutting at the standard 45° angle (Fig. 22), the saw will cut to the depth indicated on the depth of cut scale. But by raising the angle of the saw to 90° (Fig. 23), you can cut up to .414 inch (10.5mm) deeper for every one inch (25.4mm) indicated on the depth of cut scale.



Fig. 22. Depth of cut at 45°

Removing the Toolless Guard Depth Gauge

- (1) Remove the adjustment knob.
- (2) Pull off the outer section. (Safety pin will release as you pull outer section off)
- (3) Remove the inner section by pulling up from the locking key. (Fig 18 - See page 13)

Cleaning the Guard/Depth Gauge

It is important that the Guard/Depth Gauge be cleaned and inspected after each use. To clean the Guard/Depth Gauge, simply remove it, wipe off all inner and outer surfaces and reinstall on the saw. Cleaning may also be done with solvent in a parts washer.

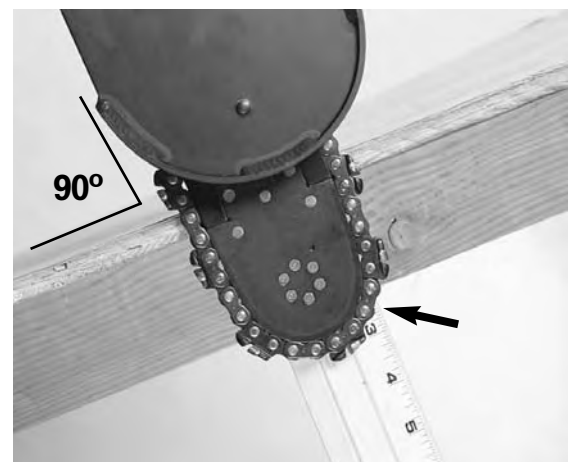
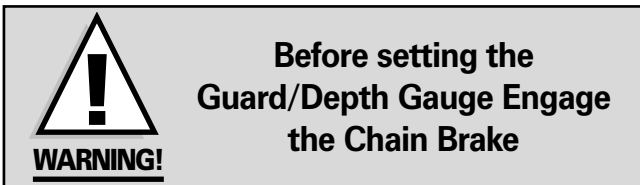

Fig. 23. Depth of cut at 90°

Note the increased depth of cut in Fig. 23 at a 90° cutting angle



Part Two: MAINTENANCE

After each use, your Cutters Edge Fire Rescue Saw should be cleaned and inspected. We recommend you develop a departmental standard operation procedure (SOP) for periodic inspection, testing and maintenance of your Fire Rescue Saw.



WARNING!

Failure to clean the saw after each use can lead to a loss of performance, engine failure and premature wear.

CLEANING

Remove the clutch cover. Inspect it and clean all foreign matter and debris from it (Fig. 24).

THE CHAIN

Remove the chain and inspect it closely. (Fig. 25)

THE BULLET® CHAIN COMPONENTS (Fig. 26)

Note: The BULLET®CHAIN is designed to allow chips of carbide to break away under normal use. If six or more cutters have 50% or more of the carbide missing you should have the chain repaired and sharpened. Do not judge the usability of the BULLET®CHAIN on visual appearance alone. The only true determination should be made on how it cuts. If you are in doubt, make a test cut to determine the chain's performance.

CHAIN REPAIR AND SHARPENING

Contact your local Cutters Edge Distributor or return your chain to Cutters Edge:

Cutters Edge

1435 Manzanita Drive
Julian, CA 92036 U.S.A.

Contact Cutters Edge for return Instructions

Tel: 760-765-0597

Fax: 760-765-0594

E-mail: repair@cuttersedge.com

We recommend you keep a minimum of two chains for each saw.



Fig. 24. Thoroughly clean the clutch cover



Fig. 25. Inspect the chain



Fig. 26. Components of the BULLET® CHAIN

THE GUIDE BAR

Remove the guide bar and wipe debris from it.

Clean out the chain groove using a bar cleaning tool or a putty knife (Fig. 27). If there is excess tar or debris buildup on the bar, clean it off with solvent.

It is also important to thoroughly clean the oil holes on both sides of the guide bar. (Fig. 28)

After cleaning the bar, lubricate the bearings in the sprocketnose (Fig. 29) with the grease and grease gun provided with each saw.



Fig. 27. Cleaning bar groove



Fig. 28. Cleaning oil holes on guide bar



Fig. 29. Lubricating sprocket bearings

When you reinstall the guide bar, flip the guide bar over so the edge that was on the bottom is now on the top. This allows even wear to the guide bar rails. Reference the logo position each time the bar is reinstalled (Fig. 30)

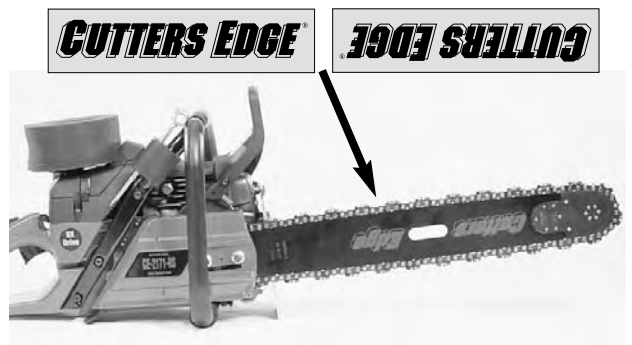

Fig. 30. Reference logo position each time you reinstall the guide bar.

THE POWER HEAD

Inspect and clean the power head. (Fig. 31)
Wipe all debris and foreign matter from the power head, making sure to clean carefully around the clutch.

Make sure the oil slot on the power head is clear and open. Use a bar cleaning tool or a small screwdriver to remove any debris from this slot. (Fig. 32)

THE AIR FILTERS

Remove the foam pre-wrap air filter from the saw (Fig. 33). Wash the pre-wrap with soapy water, rinse with clean water and squeeze dry.

The main filter element is coated at the factory and needs no oiling prior to its first use. The main filter element needs to be cleaned only if there is substantial buildup of debris. To remove the main filter, loosen the filter clamp with a screwdriver or the scrench tool. (Fig. 34)

Note: Pull out the choke to close the butterfly before removing the main filter. This will prevent foreign objects from entering the carburetor after you have removed the filter.

Clean the main filter element with soap and water, rinse with clean water and allow to thoroughly dry. It is important that the main filter element is thoroughly dry. When dry, recoat main filter element with the filter oil provided with the saw. Spray filter oil only around the exterior of the filter. Do not spray oil inside the filter element.



Fig. 31. Power Head



Fig. 32. Carefully clean out the oil slot



WARNING! Do not use solvents to clean, or compressed air to dry the filter as this may damage the filter element.

IMPORTANT! It may take up to an hour for the main filter element to thoroughly dry, depending on the weather. **NOTE:** It is a good idea to have a spare filter. Drying time can be over an hour and the extra filter can get your saw back in service faster.



Fig. 33. Remove the Pre-filter

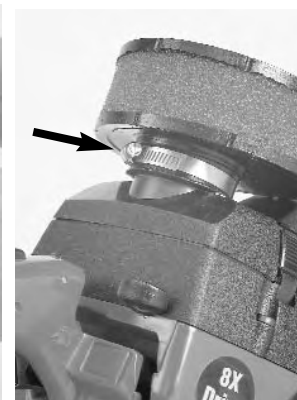

Fig. 34 Main filter clamp screw

CLEANING THE COOLING FINS ON THE CYLINDER

Remove the carburetor compartment cover by first opening the two carburetor compartment latches (1 & 2) and remove the top of the compartment that includes the main filter. Next, loosen the two screws; A & B. Then loosen the one cylinder head cover screw, C. (Fig. 35)

Remove the cylinder head cover. Check the cooling fins (Fig. 36) for excess buildup of tar and debris. If necessary, scrape clean or clean with a solvent.

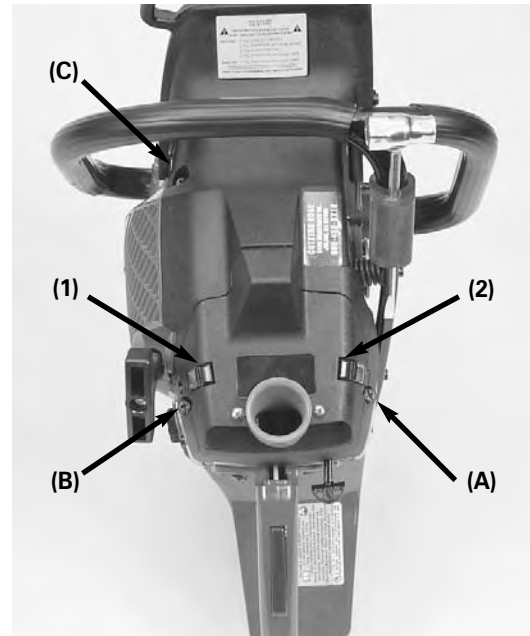

Fig. 35. The top cover with filter removed



WARNING!

The heat exchanging action of the cooling fins is critical to cooling the engine. If the fins are coated with tar or blocked by debris over heating and engine damage can occur!

REASSEMBLY

When you have completed all maintenance procedures, reassemble the saw paying attention to flip the guide bar over before you reassemble the saw.

Flip the guide bar each time you reassemble the saw. This provides even wear on the guide bar. Reference the logo position each time the bar is flipped (Fig. 30 - See page 16).

For specific engine adjustments and settings, consult the accompanying chainsaw operations manual.

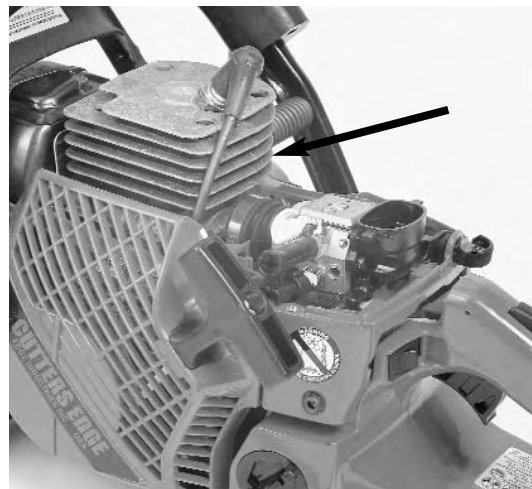

Fig. 36. Cylinder cooling fins

FINAL MAINTENANCE CHECK

When the maintenance and cleaning is completed check to make sure all nuts and screws are properly retightened. Start and run the saw briefly. Shut off and store for its next use.

**IMPORTANT! THINK! ...
IS WHAT I AM ABOUT TO DO SAFE?**

Read and follow all instructions for the proper setup, operation and maintenance of your Cutters Edge Fire Rescue Saw. Be alert while using your saw, and always strictly observe all safety procedures.

Cutters Edge Fire Rescue Saws are designed specifically for fire department use and are exceptional tools. However, as with all tools, they have their limitations. With proper care, and especially common sense, your Cutters Edge Fire Rescue Saw will give you many years of outstanding performance and reliability.

If you should have questions about the operation and/or maintenance of your **Cutters Edge Fire Rescue Saw**, call our **Service Department at 1-800-433-3716 or (760) 765-0597.**

CUTTERS EDGE FIRE RESCUE SAW SPECIFICATIONS..MODEL #CE-2165-RS**ENGINE**

TYPE: Single-cylinder 2-cycle, with loop scavenging
DISPLACEMENT: 4.0 cu. in. (65.1cc)
BORE: 1.89 in. (48mm)
STROKE: 1.4 in (36mm)
COMPRESSION RATIO: 9.4:1
BEARINGS: Heavy-duty deep-groove ball bearings on crankshaft, needle cage bearings on connecting rod, piston pin and clutch
CYLINDER/PISTON: Open ported single ring design, with four transfer ports
CYLINDER MATERIAL: Nikasil
MAX ENGINE SPEED: No load...12,500 RPM
HORSEPOWER: 5.06hp (DIN)

IGNITION SYSTEM

TYPE: Electronic, one piece modular, CD
BRAND: FHP
SPARK PLUG: Champion CJ7Y or equivalent
GAP: 0.020 in. (0.5mm)

STARTING SYSTEM

ONE STEP STARTING SYSTEM WITH COMPRESSION RELEASE
 Comprised of...
 Momentary contact switch
 Combined choke/throttle lock with Throttle safety guard

AIR FILTRATION SYSTEM:

"RAM-AIR INDUCTION"
 4-stage external mount with oil tack barrier
SURFACE AREA: 211.4 sq.in.effective filtration surface area
MICRON RATING: <1 Micron

FUEL & ENGINE LUBRICATION

GASOLINE OCTANE RATING: Use 87 octane or higher
FUEL MIX RATIO: With Cutters Edge Synthetic Oil.....100:1
 If petroleum base 2-cycle oil used: ...50:1
FUEL TANK CAPACITY: 26.8 fl.oz. (0.77 liters)

CARBURETOR ISOLATION

Designed to eliminate Vapor-lock and Vibration
TYPE: Air gap isolation and Bakeolite insulation
 Pressurized carburetor compartment keeps out dirt

DRIVE SYSTEM

TYPE: Inboard, 3-shoe centrifugal clutch
STYLE: Rim & Drum System
 Radially ported to keep rim free of tar & debris buildup... free floating to keep chain in perfect alignment with bar groove
SIZE: .404 x 7 TOOTH
CHAIN SPEED: No load chain speed 98.5FPS (feet per second)

GUIDE BAR

TYPE: Solid one piece construction
 10 Tooth Sprocketnose
 20" and 16" slotted for Guard/Depth Gauge

MATERIAL

HIGH ALLOY: .192" Thick, Bar Body
HIGH SPEED STEEL: Sprocketnose
CUTTING LENGTHS: 20" 16" and 12"
SIZE: 404 Pitch .063 Gauge

CUTTING CHAIN

STYLE: CUTTERS EDGE BULLET® CHAIN
TYPE: Carbide Tipped with "Locking Key" and Solid Bullet Raker Gauge
DESIGN: Patented Fire Rescue Design...U.S. Patent No. 5,056,395
SIZE: .404" Pitch x .063" Gauge with .068 "Drive Links (coined to .063") Heavy Duty Tie Straps, Tempered Rivets and .068" Hubs
CERTIFICATION: Meets or exceeds ANSI and OSHA standards Certified according to ISO 9518 Standards as "Extremely Low Kickback"

CUTTING CHAIN LUBRICATION SYSTEM

TYPE: Fully automatic, adjustable
DRIVE SYSTEM: Geared to Centrifugal Clutch
LUBRICANT: Cutters Edge "High Tack" Bar & Chain Oil or High Quality Bar & Chain Oil
OIL TANK CAPACITY: 14.24 fl.oz. (0.42 liters)

HANDLES

TYPE: **Front/Top...** Full Wrap (For ease of use with gloves, from either side of saw) Rubber coated for sure grip
Rear... Flared base for kickback guard. Full isolation anti-vibration

VIBRATION LEVELS

*FRONT HANDLE m/s²: *Idling* 3.1
Racing 2.6
 *REAR HANDLE m/s²: *Idling* 1.8
Racing 3.8

SILENCING MUFFLER:

Upsize, top ported, low restriction with fire screen
****NOISE LEVEL:** 104dB(A) at maximum output (**see Note1)

GUARD/DEFLECTOR

TYPE: Aluminum front mount to cover muffler and control airflow for delivery of cleaner, cooler air to cylinder heat exchangers...(Keeps engine running cooler and reduces maintenance)

CHAIN BRAKE

TYPE: Inertia Activated
STYLE: Free-Swinging Pendulum
BREAKING TIME: <0.20 second

GUARD/DEPTH GAUGE (Optional)

(No tools needed for installation, adjustments or removal)
FUNCTION: Covers all the cutting chain, allows saw operator to set depth of cut to avoid cutting structural members
MATERIAL: Anodized aluminum
TYPE: D6 for 16" saw... D8 for 20" saw... 3 point mount, positive lock with depth of cut scale
DEPTH OF CUT: D6 = 6" D8 = 8"

WEIGHTS

POWERHEAD ONLY: 15.25 lbs (Dry Weight)
CE-2165RS-12": 18 lbs
CE-2165RS-16": 18.5 lbs
CE-2165RS-20": 19.3 lbs
CE-2165RS/D6: 20.6 lbs
CE-2165RS/D8: 21.65 lbs

STANDARD ACCESSORIES

ACCESSORIES INCLUDED WITH ALL FIRE RESCUE SAWS...
 "Scrench" holder and "Scrench" tool, complete tool kit including grease gun and packet of grease, complete manuals, filter oil, Cutters Edge 2-cycle oil mix, Cutters Edge bar & chain oil, bar scabbard (saws without D6 & D8 only)

**Note 1: Equivalent noise level is, according to ISO 7182 and ISO 9207 calculated as the time-weighted energy total for noise levels under various working conditions with the following time distribution: 1/3 idle, 1/3 full load, 1/3 full speed.

**Note 2: Equivalent vibration level is, according to ISO 7505, calculated as the time-weighted energy total for vibration levels under various working conditions with the following time distribution: idle, full speed.

CUTTERS EDGE FIRE RESCUE SAW SPECIFICATIONS..MODEL #CE-2171-RS

ENGINE

TYPE: Single-cylinder 2-cycle, with loop scavenging
DISPLACEMENT: 4.3 cu.in. (70.7cc)
BORE: 1.97 in. (50mm)
STROKE: 1.4 in (36mm)
COMPRESSION RATIO: 10.2:1
BEARINGS: Heavy-duty deep-groove ball bearings on crankshaft, needle cage bearings on connecting rod, piston pin and clutch
CYLINDER/PISTON: Closed ported, dual rings with four transfer ports
CYLINDER MATERIAL: Nikasil
MAX ENGINE SPEED: No load... 13,500 RPM
HORSEPOWER: 5.67hp (DIN)

IGNITION SYSTEM

TYPE: Electronic, one piece modular, CD
BRAND: FHP
SPARK PLUG: Champion CJ7Y or equivalent
GAP: 0.020 in. (0.5mm)

STARTING SYSTEM

ONE STEP STARTING SYSTEM WITH COMPRESSION RELEASE
 Comprised of...
 Momentary contact switch
 Combined choke/throttle lock with Throttle safety guard

AIR FILTRATION SYSTEM:

TYPE: "RAM-AIR INDUCTION"
 4-stage external mount with oil tack barrier
SURFACE AREA: 211.4 sq.in. effective filtration surface area
MICRON RATING: <1 Micron

FUEL & ENGINE LUBRICATION

GASOLINE OCTANE RATING: Use 87 octane or higher
FUEL MIX RATIO: With Cutters Edge Synthetic Oil..... 100:1
 If petroleum base 2-cycle oil used: ...50:1
FUEL TANK CAPACITY: 26.8 fl.oz. (0.77 liters)

CARBURETOR ISOLATION

Designed to eliminate Vapor-lock and Vibration
TYPE: Air gap isolation and Bakeolite insulation
 Pressurized carburetor compartment keeps out dirt

DRIVE SYSTEM

TYPE: Inboard, 3-shoe centrifugal clutch
STYLE: Rim & Drum System
 Radially ported to keep rim free of tar & debris buildup... free floating to keep chain in perfect alignment with bar groove
SIZE: .404 x 8 TOOTH
CHAIN SPEED: No load chain speed 121.6 FPS (feet per second)

GUIDE BAR

TYPE: Solid one piece construction
 10 Tooth Sprocketnose
 20" and 16" slotted for Guard/Depth Gauge

MATERIAL

HIGH ALLOY: 192" Thick Bar Body
HIGH SPEED STEEL: Sprocketnose
CUTTING LENGTHS: 20" 16" and 12"
SIZE: 404 Pitch .063 Gauge

CUTTING CHAIN

STYLE: CUTTERS EDGE BULLET® CHAIN
TYPE: Carbide Tipped with "Locking Key" and Solid Bullet Raker Gauge
DESIGN: Patented Fire Rescue Design...U.S. Patent No. 5,056,395
SIZE: .404"Pitch x .063" Gauge with .068 "Drive Links (coined to .063") Heavy Duty Tie Straps, Tempered Rivets and .068"Hubs
CERTIFICATION: Meets or exceeds ANSI and OSHA standards Certified according to ISO 9518 Standards as "Extremely Low Kickback"

CUTTING CHAIN LUBRICATION SYSTEM

TYPE: Fully automatic, adjustable
DRIVE SYSTEM: Geared to Centrifugal Clutch
LUBRICANT: Cutters Edge "High Tack" Bar & Chain Oil or High Quality Bar & Chain Oil
OIL TANK CAPACITY: 14.24 fl.oz. (0.42 liters)

HANDLES

TYPE: **Front/Top...** Full Wrap (For ease of use with gloves, from either side of saw) Rubber coated for sure grip
Rear... Flared base for kickback guard. Full isolation anti-vibration

VIBRATION LEVELS

*FRONT HANDLE m/s²: *Idling* 3.4
Racing 2.2
 *REAR HANDLE m/s² : *Idling* 1.8
Racing 3.8
 (*see Note 2)

SILENCING

MUFFLER: Oversize, top ported, low restriction with fire screen
****NOISE LEVEL:** 104dB(A) at maximum output (**see Note1)

GUARD/DEFLECTOR

TYPE: Aluminum front mount to cover muffler and control airflow for delivery of cleaner, cooler air to cylinder heat exchangers...(Keeps engine running cooler and reduces maintenance)

CHAIN BRAKE

TYPE: Inertia Activated
STYLE: Free-Swinging Pendulum
BREAKING TIME: <0.20 second

GUARD/DEPTH GAUGE (Optional)

FUNCTION: (No tools needed for installation, adjustments or removal) Covers all the cutting chain, allows saw operator to set depth of cut to avoid cutting structural members
MATERIAL: Anodized aluminum
TYPE: D6 for 16" saw... D8 for 20" saw... 3 point mount, positive lock with depth of cut scale
DEPTH OF CUT: D6 = 6" D8 = 8"

WEIGHTS

POWERHEAD ONLY: 15.25 lbs (Dry Weight)
CE-2171RS-12": 18 lbs
CE-2171RS-16": 18.5 lbs
CE-2171RS-20": 19.3 lbs
CE-2171RS/D6: 20.6 lbs
CE-2171RS/D8: 21.65 lbs

STANDARD ACCESSORIES

ACCESSORIES INCLUDED WITH ALL FIRE RESCUE SAWS...
 "Srench" holder and "Srench" tool, complete tool kit including grease gun and packet of grease, complete manuals, filter oil, Cutters Edge 2-cycle oil mix, Cutters Edge bar & chain oil, bar scabbard (saws without D6 & D8 only)

**Note 1: Equivalent noise level is, according to ISO 7182 and ISO 9207 calculated as the time-weighted energy total for noise levels under various working conditions with the following time distribution: 1/3 idle, 1/3 full load, 1/3 full speed.

*Note 2: Equivalent vibration level is, according to ISO 7505, calculated as the time-weighted energy total for vibration levels under various working conditions with the following time distribution: idle, full speed.

CUTTERS EDGE LIMITED WARRANTY

Effective 7-1-92

As Limited Below,

Edge Industries, Inc., warrant to the original retail purchaser that this Cutters Edge Saw is free from defects in materials and workmanship and agree to repair and/or replace any defective saw part or component free of charge as follows:

1. Parts other than electronic ignition parts

At no cost to the original retail purchaser, Edge Industries, Inc., will replace defective parts supplied or manufactured by Edge Industries, Inc.:

- A. For one year from date of original purchase when used for fire department applications.
- B. For 30 days from date of original purchase when saw is used for commercial purposes, except as listed below in section 2.
- C. A saw is used for commercial purposes when it is used to derive income.

2. Extended warranty:

Selected saw models used commercially may have warranty extended.

Electronic ignition parts:

- A. For six months from the date of original purchase, Edge Industries, Inc., will replace any defective electronic ignition parts supplied or manufactured by Edge Industries, Inc. at no cost to the original purchaser.
- B. For a period starting six months and ending one year after the original retail purchase, Edge Industries, Inc., will replace any defective electronic ignition parts supplied or manufactured by Edge Industries, Inc., at a charge to the original purchaser of 50% of Edge Industries™ suggested retail price.

Engine parts:

- A. For six months from date of original purchase, Edge Industries, Inc., will replace any defective engine part supplied or manufactured by Edge Industries, Inc. at no cost to the original purchaser subject to the limitations of paragraph 5 below.
- B. Engine parts are limited to cylinder assembly, crankshaft, crankcase and flywheel.

3. Labor:

For 30 days from the date of original purchase, an authorized Edge Industries, Inc. dealer will provide labor at no charge to the original retail purchaser for the replacement of any defective part supplied or manufactured by Edge Industries, Inc.

4. Grantor of Warranty:

Edge Industries, Inc. • 1435 Manzanita Drive , Julian, CA 92036 U.S.A. • 760-765-0597

5. Limitations of Warranty:

This warranty is not transferable, does not cover damage caused by unreasonable use or damage resulting from other than defects in material or workmanship, does not cover damages contributed to by a failure to provide reasonable and necessary maintenance, does not cover engine failure due to lack of or improper lubrication. Tune-ups or replacement of non-defective parts such as mounts, starter springs, ropes, spark plugs, and filters that may be expected to wear out with reasonable use during the warranty period are not covered. This warranty applies only to saws sold through dealers appointed by Edge Industries, Inc.

THE WARRANTOR WILL BE LIABLE FOR NO INCIDENTAL OR CONSEQUENTIAL DAMAGES. THERE ARE NO EXPRESS WARRANTIES OTHER THAN THOSE SET FORTH ABOVE. ANY WARRANTY IMPLIED BY STATE LAW WHETHER MERCHANTABILITY OR FITNESS FOR A PARTICULAR PURPOSE OR OTHERWISE SHALL BE EFFECTIVE ONLY FOR THE DURATION OF THE APPLICABLE WARRANTY PERIOD LISTED ABOVE. Some states do not allow exclusions of incidental or consequential damages and/or limitations on how long an implied warranty lasts, so the above exclusions and limitations may apply to you.

6. Responsibilities of the purchaser under this Warranty:

- A. To deliver or ship the saw covered under this Warranty to the dealer from whom it was originally purchased or to an Edge Industries, Inc., authorized service center. Time limits on warranties are measured to the date of delivery or shipment.
- B. Freight costs, if any, will be borne by the purchaser.
- C. To provide reasonable care and maintenance of the Edge Industries, Inc., product.

7. Timely repair of warranted product:

Any product which qualifies under this Warranty shall be repaired in a timely manner, consistent with the normal work flow at the servicing location and depending on the availability of replacement parts.

8. Purchaser rights and remedies:

This Warranty gives you specific legal rights. You may also have other rights, which vary from state to state. If you do not receive satisfactory results from authorized servicing stations, you may contact Edge Industries, Inc., Customer Relations Department, P.O. Box 1179, Julian, CA. 92036.



Division of Edge Industries, Inc.

Cutters Edge Offices

P.O. Box 846
3855 23rd Street
Baker City, Oregon 97814
Telephone: 541-524-9999
Fax: 541-524-9996
Email info@cuttersedge.com

East Coast Service Center

Eastern Fire Equipment Services
326 Pleasant View Rd.
New Cumberland, PA 17070
Tel: 717-412-7746
Email: office@efesinc.com

www.cuttersedge.com