



AMX240 Audio Panel Installation Manual



Document P/N 200-890-0240

July 2014

This document is applicable to the Avidyne AMX240 Audio Panel

For technical support, please contact Avidyne using the following information.

888-723-7592

781-402-7592

techsupport@avidyne.com

All materials copyrighted, including images that represent this software.

Copyright 2014 Avidyne Corporation. All rights reserved.

The latest installation manuals are available to authorized dealers on the web at
www.avidyne.com.

Table of Contents

Section I – GENERAL INFORMATION.....	1
1.1 INTRODUCTION	1
1.2 SCOPE	1
1.3 EQUIPMENT DESCRIPTION	1
1.4 APPROVAL BASIS.....	2
1.5 SPECIFICATIONS	2
1.6 EQUIPMENT SUPPLIED	4
1.7 EQUIPMENT REQUIRED BUT NOT SUPPLIED.....	4
1.8 LICENSE REQUIREMENTS	4
1.9 PLUG AND PLAY COMPATIBILITY	4
Section II - INSTALLATION	6
2.1 GENERAL INFORMATION	6
2.1.1 SCOPE	6
2.1.2 CERTIFICATION REQUIREMENTS	6
2.2 UNPACKING AND PRELIMINARY INSPECTION.....	6
2.3 EQUIPMENT INSTALLATION PROCEDURES	6
2.3.1 COOLING REQUIREMENTS	6
2.3.2 MOUNTING REQUIREMENTS.....	6
2.3.3 AUDIO PANEL MOUNTING RACK INSTALLATION	6
2.3.4 AUDIO PANEL TRAY AND CONNECTOR ASSEMBLY.....	6
2.4 CABLE HARNESS WIRING	7
2.4.1 ELECTRICAL NOISE	7
2.4.2 POWER.....	8
2.4.3 AUDIO PANEL INTERFACE	8
2.4.4 TRANSMIT INTERLOCK.....	8
2.4.5 BACKLIGHTING	8
2.4.6 UNSWITCHED INPUTS	8
2.4.7 "SWAP" MODE.....	9
2.4.8 TEL (DUPLEX) FUNCTION FOR CELL PHONES	9
2.4.9 PUBLIC ADDRESS MODE	10
2.4.10 PA MUTE (J2, PIN 12).....	11
2.4.11 SPLIT/COM 2 SELECT.....	11
2.5 INTERCOM WIRING	11
2.5.1 ENTERTAINMENT INPUTS	11
2.5.2 ENTERTAINMENT MUTING.....	12
2.5.3 CONFIGURING MUSIC INPUT WITH FUNCTION KEYS	12
2.5.4 PLAYBACK BUTTON INSTALLATION.....	12
2.6 MARKER BEACON INSTALLATION.....	12
2.6.1 MARKER ANTENNA INSTALLATION	12
2.6.2 EXTERNAL MARKER LIGHTS.....	12
2.6.3 MIDDLE MARKER SENSE.....	13
2.7 ADJUSTMENTS.....	13
2.8 COMMUNICATIONS ANTENNA INSTALLATION NOTES.....	14
2.9 AMX240 PIN ASSIGNMENTS.....	15
2.10 WIRING CHECKOUT.....	16
2.11 UNIT INSTALLATION	16
2.12 OPERATIONAL CHECKOUT.....	16
2.12.1 REQUIRED TEST EQUIPMENT	16
2.12.2 AUDIO PANEL TEST	16
2.12.3 MARKER CHECKOUT	17
2.12.4 TEL CHECKOUT	17

AMX240 Audio Panel Installation Manual

2.12.5	INTERNAL RECORDER CHECKOUT	17
2.13	FINAL INSPECTION.....	17
	Section III OPERATION.....	18
3.1	SCOPE.....	18
3.2	COMMUNICATIONS TRANSMIT (XMT) (2) AND RECEIVE SELECTION (3)	18
3.2.2	TRANSCEIVER MONITOR (6).....	19
3.3	NAV AUDIO SELECTOR (6).....	19
3.4	TELEPHONE (TEL) (5).....	19
3.4.1	CELL PHONE SIDETONE	20
3.5	SPEAKER AMPLIFIER (6).....	20
3.6	MARKER BEACON OPERATION (1).....	20
3.7	INTERCOM OPERATION	20
3.7.1	INTELLIVox® VOX-SQUELCH.....	20
3.7.2	INTERCOM VOLUME CONTROL (7 & 9)	21
3.7.3	INTERCOM MODES (4)	21
3.8	MUSIC AND MUSIC MUTING (10).....	22
3.8.1	MUSIC IN PILOT ISO MODE (8).....	23
3.9	TELEPHONE MODE (5).....	23
3.9.1	CELLULAR TELEPHONE SIDETONE.....	24
3.10	UTILITY JACK	24
3.10.1	CELLULAR PHONE	24
3.10.2	AUDIO ADVISORY INPUT.....	24
3.10.3	MUSIC INPUT	24
3.11	BLUETOOTH® INTERFACE.....	24
3.11.1	PAIRING AND UNPAIRING BLUETOOTH DEVICES	24
3.12	INTERNAL RECORDER AND PLAYBACK	25
	Appendix A – AMX240 Installation Drawings	26
	Appendix B – J1 Connector Interconnect – see separate markup.	27
	Appendix C – J2 Connector Interconnect	28
	Appendix D – Instructions for FAA Form 337 and continuing airworthiness	29
7.1	INSTRUCTIONS FOR FAA FORM 337, AUDIO PANELS.....	29
7.2	INSTRUCTIONS FOR CONTINUING AIRWORTHINESS, AUDIO SYSTEM.....	29
	Appendix E – RTCA DO160D Environmental Qualification Form	30

Rev	Date	Change
0	November 2013	New Release of manual p/n -0240, for AMX240
1	November 2013	Release for publication
2	July 2014	Correct Avidyne Part Numbers, minor cleanup

Section I – GENERAL INFORMATION

1.1 INTRODUCTION

The AMX240 represents another evolutionary step in cockpit audio control and intercommunications utility. Using a patented *IntelliVox*® design, front panel utility jack, and pilot programmable configurations, this marks the next level of audio control. The unit is designed for outstanding ergonomics with visually and aurally defined mode announcement and selection.

Before installing and/or using this product, please read this manual completely. This will ensure that you will take full advantage of all the advanced features in the AMX240.

1.2 SCOPE

This manual provides detailed installation and operation instructions for the Avidyne AMX240-series of Audio Selector Panel/Intercom Systems. This includes the following units:

<u>Model</u>	<u>Description</u>	<u>Part Number</u>	<u>Avidyne Part Number</u>
AMX240	Stereo Audio Selector Panel with Marker Beacon, includes utility jack and Internal Recorder System	050-890-0240	200-00253-000

1.3 EQUIPMENT DESCRIPTION

The AMX240 is a state-of-the-art audio isolation amplifier and audio selector that contains an automatic voice activated (VOX) intercom system and integral marker beacon receiver. It can switch two transceivers (COM 1, COM 2) and five receivers (NAV 1, NAV 2, MON 1, MON 2 and MKR).

A full duplex TEL mode allows the AMX240 to act as an audio interface between aircraft headphone and microphones and specific aircraft approved (FAA/FCC) cellular telephone equipment.

Warning: Use of non-aviation approved cellular telephone equipment may be prohibited by FCC regulation. Avidyne is not responsible for unauthorized airborne use of cellular telephones. For airborne use, the AMX240 must be interfaced with an approved system.

There are five unswitched inputs, available for traffic or EGPWS, autopilot disconnect, and/or radar altimeter warning, with the fifth unswitched input through a front-mounted utility jack, when configured to act as a fifth unswitched input.

Pushbuttons select the receiver audio source provided to the headphones. A SPKR button allows the user to listen to the receiver(s) selected on the cabin speaker. Except for the unswitched inputs, all speaker audio is muted during transmit. Unswitched inputs 1, 3, and 4 are always presented to the aircraft speaker. Unswitched input 2 will be presented to the speaker when the front panel SPKR push button has been selected.

Pushbutton switches (MIC 1 or MIC 2) allow you to select one of the communication transceivers for the pilot and copilot position which allows radio transmission. In "Split Mode" the AMX240 has the ability to allow the pilot to transmit on COM 1 while the copilot can transmit on COM 2. A fail-safe mode connects the pilot headphone and microphone to COM 1 if power is removed for any reason, or if the power switch is placed in the Off (Fail-safe) position. Unswitched input #1 is also provided to the pilot headphone in fail-safe

A six-station voice activated (VOX) stereo intercom is included inside the AMX240. This system has patented *IntelliVox*® circuitry that eliminates manual adjustments to help eliminate background noise. The intercom system incorporates pilot isolate, all and crew modes, two independent stereo music inputs with "SoftMute™". Intercom volume controls are through front panel knobs, pilot on the left with the copilot & passengers being on the concentric control located on the right hand side. The small volume knob controls the intercom level for the pilot and copilot, while the large knob on the right hand side controls the passenger intercom volume. Intercom squelch is automatic and hands free.

AMX240 Audio Panel Installation Manual

A 3-light, 75 MHz Marker Beacon receiver is integrated in the AMX240. This provides the necessary Marker Beacon lights and audio indications necessary for that portion of an Instrument Landing System (ILS) approach. A pushbutton labeled MKR allows the pilot to select the audio.

In the AMX240, a Bluetooth® wireless interface is available for wireless telephone and music connection.

1.4 APPROVAL BASIS

FAA TSO Approval.

The AMX240-series Audio Selector Panels are FAA approved under TSO C50c (Audio Amplifiers) and TSO C35d (Marker Beacon Receivers), ETSO C50C/ and 2C53d.

Manufacturer and TSO holder is PS Engineering, Inc. Lenoir City Tennessee, USA.

All systems comply with relevant portions of EUROCAE RTCA MPS WG No. 7/70, DO-143 and (*Marker Beacon Receivers*), ED-14C/DO-160C (*Environmental Conditions and Test Procedures for Airborne Equipment*), ED12B/DO-178B, Level D (*Software Considerations for Airborne Equipment*) and ED- 18/DO-214 (*Audio Systems Characteristics and Minimum Operational Performance Standards for Aircraft Audio Systems*).

Operation is subject to the following conditions:

This device may not cause harmful interference.

This device must accept any interference received, including interference that may cause undesired operation.

1.5 SPECIFICATIONS

TSO COMPLIANCE	
<i>Marker Beacon:</i>	FAA TSO C35d, Class A ETSO 2C35d
<i>Audio Selector/Intercom:</i>	FAA TSO C50c, Class 1a ETSO C50c
APPLICABLE DOCUMENTS:	RTCA/DO-214 RTCA/DO-143 RTCA/DO-160D RTCA/DO-178B DO-254
ENVIRONMENTAL Qualifications:	A1D1CABSUXXXXXXXZBABATBXE2XXX
<i>Operating Temperature Range:</i>	-15° C to 55° C
<i>Altitude:</i>	Up to 50,000 feet in an non-pressurized area
DIMENSIONS:	Height: 1.3 in. (3.3 cm) Width: 6.25 in. (16.9 cm) Depth behind panel 7.15 in. (18.16 cm)
WEIGHT	
<i>AMX240 Unit</i>	1.34 lb. (0.61 kg)
<i>Rack with connectors</i>	0.51 lb. (0.24 kg)
POWER REQUIREMENTS (Including Internal Lighting):	
<i>Voltage:</i>	11 to 33 VDC
<i>Maximum Current:</i>	2.5 Amp (Externally protected by a 5A pull-type breaker)

AMX240 Audio Panel Installation Manual

Audio Selector Specifications

<i>Audio selector panel input impedance:</i>	510 Ω
<i>Input Isolation:</i>	-60 dB (min.)
<i>Speaker Muting:</i>	-60 dB (min.)
<i>Speaker Output (into 4 Ω) with no clipping</i>	
14 VDC:	3 Watts (min.)
28 VDC:	10 Watts (min.)
<i>Receiver Inputs:</i>	9 (COM 1, COM 2, MON 1, MON 2, TEL (J), NAV 1, NAV 2, DME, MKR)
<i>Unswitched Inputs:</i>	6 (including front jack)
<i>Transmitter Selections:</i>	4 (COM 1, COM 2, TEL COM 1/2)
<i>Speaker Impedance:</i>	4 Ω
<i>Headphone Impedance:</i>	150 – 1000 Ω
<i>Headphone Output:</i>	38 mW each headset, no clipping <1% THD typical
<i>Microphone Impedance:</i>	150 - 600 Ω
<i>Bluetooth Radio (AMX240 -0240 only)</i>	Class 3, FCC ID QOQWT32AE

Intercom Specifications

<i>Intercom Positions:</i>	6 places (with individual <i>IntelliVox</i> ® circuits)
<i>Music Inputs:</i>	2, (Independent, Stereo)
<i>Music Muting:</i>	>-30 dB "Soft Mute" when COM or intercom active.
<i>Distortion:</i>	<1% THD @ 38 mW into 150 Ω
<i>Mic Freq. Response, 3 dB:</i>	300 Hz - 6000 Hz
<i>Music Freq. Response, 3 dB:</i>	10 Hz – 26 kHz

MARKER BEACON RECEIVER:

<i>Frequency:</i>	75 MHz Crystal Controlled
<i>Sensitivity:</i>	Capable of: (preset at factory for field application)
Low:	1000 μ Volts (Hard) (360 to 570 μ V soft)
High:	200 μ Volts (Hard) (130 to 200 μ V soft)
<i>Selectivity:</i>	-6 dB at \pm 10 kHz -40 dB at \pm 120 kHz
<i>External Lamp Output:</i>	7.5 (\pm 4 VDC unloaded, at maximum brightness) VDC positive when active, max. current 125 mA
<i>MM Sense:</i>	Active high (4.5 \pm 1.0VDC)

AMX240 Audio Panel Installation Manual

1.6 EQUIPMENT SUPPLIED

1 ea. of the following units:

Model	Description	PS Engineering Part Number	Avidyne Part Number
AMX240	AMX240 Audio Panel with Marker, Stereo Intercom, and Bluetooth connectivity	050-890-0240	200-00253-000

The following installation components are included with the AMX240.

Description	Quantity	Part Number
Installation rack assembly	1	430-890-0040
Rack back plate	1	430-890-0050
44-pin connector kit	2	120-891-2045
Backshell, connector	2	625-025-2465
Backshell Retainer	2	431-881-0100
Mounting Block	2	431-891-0100
4 40 X 7/16 screw w/nylon patch	4	475-440-0007
4 40 X 3/8 screw w/nylon patch	4	475-440-1038
4-40 x 1/4" screw with lock washer	2	475-440-0001
Solder Grounding Lug	2	475-009-0001
Cable Clamp	1	625-001-0002
#6-32 x 1/2" Flat head Philips screw	6	475-632-0012
#6-32 Clip Nut	6	475-630-0002

1.7 EQUIPMENT REQUIRED BUT NOT SUPPLIED

- Circuit Breaker: 1 ea; 5 amp PULL TYPE REQUIRED for AMX240
- Speaker, 4 Ω
- Headphone Jacks (Stereo, as Required)
- Microphone Jacks (as Required)
- Headphones, 150 Ω (Stereo), up to 6 as required
- Microphones, up to 6 as required
- Marker Antenna (75 MHz, VSWR <1:1.5, and appropriate for the airspeed)
- Interconnect Wiring

1.8 LICENSE REQUIREMENTS

None

AMX240 (050-890-0240) Bluetooth™ Radio approval:

- FCC ID: QQQWT32AE
- Industry Canada ID: 5123A-BGTWT32AE
- CE EMC Directive 89/336/EEC as amended by Directives 92/31/EEC and 93/68/EEC

1.9 Plug and Play Compatibility

The AMX240 is plug & play compatible with:

- Garmin GMA 340;
- PS Engineering PMA8000;
- PS Engineering PMA8000B;
- PS Engineering PMA8000BT;
- PS Engineering PMA8000B/BT/MP3 for Avidyne R9;
- PS Engineering PMA8000C;
- PS Engineering PMA5000EX.

This means the AMX240 can literally be installed in one of those trays and no further action or wiring is required but some functions may be missing without adding wiring or are not supported. The following tables identify the

AMX240 Audio Panel Installation Manual

functions that either don't exist in the AMX240 or will need extra wiring if they are to be available when replacing one of the legacy audio panels that are tray compatible.

This table indicates functions that may have existed in your legacy audio panel but are not available in the AMX240. An "X" in the block indicates the function that may exist in the legacy audio panel but is not available in the AMX240.

Features Not Supported by AMX240	PMA8000	PMA8000B	PMA8000BT	PMA8000B/BT/MP3 for R9	PMA8000C	PMA5000EX	GMA340
Feature/Function	X	X	X				
CNX80 Inhibit							
COM 3 Input and MIC					X		X

Legacy Audio Panel Features Not Supported by AMX240

This table indicates functions where extra wiring may need to be added to the AMX240 tray if that function is desired. An "X" in the block indicates the optional function that may need extra wiring if replacing a legacy audio panel with the AMX240. See the AMX240 Installation Manual for details.

Extra Wiring Required	PMA8000	PMA8000B	PMA8000BT	PMA8000B/BT /MP3 for R9	PMA8000C	PMA5000EX	GMA340
Marker Sensitivity	X	X	X	X		X	
Marker Beacon Receiver						X	
Split COM (R9 display)	X	X	X		X	X	X
PA Mode						X	
Playback	X					X	
Speaker Support						X	
MON1 & MON2	X	X	X			X	X

AMX240 Audio Panel Features Requiring Extra Wiring

Section II - INSTALLATION

2.1 GENERAL INFORMATION

2.1.1 SCOPE

This section provides detailed installation and interconnection instructions for the Avidyne AMX240 Audio Selector Panel/Intercom/ with internal Marker Beacon.

Please read this manual carefully before beginning any installation to prevent damage and post-installation problems. Installation of this equipment requires special tools, test equipment (refer to §2.12.1) and knowledge as required by 14 CFR 65.81(b).

2.1.2 Certification Requirements

NOTE

The AMX240 requires specialized knowledge and tools for an effective installation. An appropriately rated Certified Aircraft Repair Station **must** install this equipment in accordance with applicable regulations. The warranty is not valid unless the equipment is installed by an authorized Avidyne dealer.

Failure to follow any of the installation instructions, or installation by a non-certified individual or agency will **void the warranty**, and may result in an **unairworthy** installation.

2.2 Unpacking and Preliminary Inspection

Use care when unpacking the equipment. Inspect the unit and parts supplied for visible signs of shipping damage. Examine the unit for loose or broken buttons, bent knobs, etc. Verify the correct quantity of components supplied with the list in Section 1.6. If any claim is to be made, save the shipping material and contact the freight carrier. Do NOT return unit damaged in shipping to Avidyne. If the unit or accessories show any sign of external shipping damage, contact Avidyne to arrange for a replacement. Under no circumstances attempt to install a damaged unit in an aircraft. Equipment returned to Avidyne for any other reason should be shipped in the original Avidyne packaging, or other UPS approved packaging.

2.3 Equipment Installation Procedures

2.3.1 Cooling Requirements

Forced air-cooling of the AMX240 is not required. However, the units should be kept away from heat producing sources (i.e. defrost or heater ducts, dropping resistors, heat producing avionics) without adequate cooling air provided.

2.3.2 Mounting Requirements

The AMX240 must be rigidly mounted to the instrument panel of the aircraft structure, within view and reach of the pilot position(s). Installation must comply with FAA Advisory Circular AC 43.13-2B, or other FAA-approved aircraft technical data. The unit may be mounted in any area where adequate clearance for the unit and associated wiring bundle exist.

To prevent noise, avoid installing the unit close to high current devices or systems with high-voltage pulse type outputs, such as DME or transponders. Avoid running the interconnecting bundles near any high current wires.

2.3.3 Audio Panel Mounting Rack Installation

Remove the unit from the mounting tray by unscrewing the 3/32" hex-head screw that is in the center of the unit. Carefully slide the unit free of the tray. Set the unit aside in a safe location until needed. Install the tray using six clip nuts (475-630-0002), and six FHP 6-32 x 1/2" screws (475-632-0012). The audio selector panel must be supported at front and rear of the mounting tray.

2.3.4 Audio Panel Tray and Connector Assembly

The rack connectors mate with two 44-pin connectors in the AMX240. The connectors are a sub-miniature crimp-type, and require the use a hand crimp tool, from table below (or equiv.). The connectors are mounted to the tray back plate with #4-40 x 3/8" screws, 475-440-1038, from the inside of the tray and the mounting block, 431-891-

AMX240 Audio Panel Installation Manual

0100. Ensure that proper strain relief and chafing precautions are made during wiring and installation, using the cable clamp, 625-001-0002.

Two solder grounding lugs, 475-009-0001, are provided, which may be attached to the rear mounting plate with 2 ea #4-40 x 1/4" screws with captivated lock washers. These provide a convenient location to connect the shield ground terminations.

Manufacturer	Crimping Tool	Positioner	Extraction tool
AMP	601966-1	601966-6	91067-1
Daniels	AFM8	K42	M24308-1
ITT-Cannon	995-0001-584	995-0001-739	91067-1

Table 2-1 Connector Pin crimping tools

2.4 Cable Harness Wiring

Referring to the appropriate Appendix, assemble a wiring harness as required for the installation. All wires must be MIL-SPEC in accordance with current regulations. Two- and three-conductor shielded wire must be used where indicated, and be MIL-C-27500 or equivalent specification. Proper stripping, shielding and soldering technique must be used at all times. It is imperative that correct wire be used.

Refer to FAA Advisory Circular 43.13-2B for more information. Failure to use correct techniques may result in improper operation, electrical noise or unit failure. Damage caused by improper installation will void the Avidyne warranty.

2.4.1 Electrical Noise

Due to the variety and the high power of radio equipment often found in today's general aviation aircraft, there is a potential for both radiated and conducted noise interference.

The AMX240 power supply is specifically designed to reduce conducted electrical noise on the aircraft power bus by at least 50dB. Although this is a large amount of attenuation, it may not eliminate all noise, particularly if the amplitude of noise is very high. There must be at least 13.8 VDC present at the connector, J2 pins 8 & 9, of the AMX240 for the power supply to work in its designed regulation. Otherwise, it cannot adequately attenuate power line noise. Shielding can reduce or prevent radiated noise (i.e., beacon, electric gyros, switching power supplies, etc.) However, installation combinations can occur where interference is possible. The AMX240 was designed in a RFI hardened chassis and has internal Electromagnetic Interference (EMI) filters on all inputs and outputs.

Ground loop noise occurs when there are two or more ground paths for the same signal (i.e., airframe and ground return wire). Large cyclic loads such as strobes, inverters, etc., can inject noise signals onto the airframe that are detected by the audio system. Follow the wiring diagram very carefully to help ensure a minimum of ground loop potential. Use only Mil Spec shielded wires (MIL-C-275000, or better). Under no circumstances combine a microphone and headphone wiring into the same shielded bundle. Always use a 2- or 3-conductor, shield wire as shown on the installation-wiring diagram.

The shields can be daisy-chained together, and then connected to the ground lugs mounted on the back plate shown in Appendix B.

Radiated signals can be a factor when low level microphone signals are "bundled" with current carrying power wires. Keep these cables physically separated. It is very important that you use insulated washers to isolate the ground return path from the airframe to **all** headphone and microphone jacks.

2.4.1.1 Music Inputs and Noise

AMX240 units utilize a differential input to help prevent noise from entering the music system. This feature is usually transparent to the installer; however, it is important that the appropriate music signal and ground connections are made directly to the dedicated music signal and ground inputs on the AMX240. The power for IFE and audio panel should be a common bus.

If a music jack instead of a music source is installed for Music 1 or 2, we recommend grounding the jack to airframe ground.

NOTE

AMX240 Audio Panel Installation Manual

Adding a high-performance audio control system, particularly in conjunction with high-performance active noise canceling headsets, cannot improve on older avionics that were designed for cabin-speaker use. Avidyne makes no claim that the audio panel will provide a noise-free audio quality under all installation conditions, particularly with older avionics.

2.4.2 Power

The AMX240 is compatible with both 14 and 28 Volt DC systems. A five (5) Amp circuit breaker is required for all installations. Power and ground wires should be #22 connected to J2 Pins 8 and 9. Connect airframe ground to J2 Pin 10 and 11 only.

2.4.3 Audio Panel interface

The AMX240 is designed to interface with standard aircraft avionics, and presents a 510 Ω receiver impedance. For best results, a twisted-shielded cable is recommended from the avionics audio source to the audio panel, with the shield grounded at the audio panel end.

Some avionics do not provide a separate audio low, and may introduce additional electrical noise into the system. For best results, connect the audio low from the audio panel to the radio ground, using one conductor of the twisted-shielded cable.

2.4.4 Transmit Interlock

Some communications transceivers use a transmit-interlock system. To fully utilize the Split Mode feature, this function must be disabled. Consult that manufacturer's radio installation manual for details.

2.4.5 Backlighting

Control of the unit backlighting and indicator intensity is through the aircraft avionics dimmer. For 14 V aircraft, connect J2 Pins 6 and 7 to the aircraft dimmer bus, and pin 5 to ground. For 28-volt systems, connect pin 7 to the aircraft dimmer, and pins 5 and 6 to ground.

When the aircraft dimmer is turned to minimum (or off) the lighting will automatically go to full bright.

2.4.6 Unswitched inputs

J1, pins 31, 29 and J2 pin 15 are unswitched, unmuted (by transmitter keying), inputs # 1, 3 and 4, respectively. These inputs are presented to the pilot and copilot regardless of the audio configuration, and will always mute the entertainment inputs. These 510 Ω inputs can be used for altimeter DH audio, GPS waypoint audio, autopilot disconnect tones, or any other critical audio signal. Unswitched #1 is always presented to the speaker, plus to the crew headphones, and is available to the pilot in fail-safe (off) mode. Unswitched 3 and 4 inputs are always presented to the crew headphones and to the aircraft speaker.

Unswitched Input	Hear in Fail Safe	Hear in Crew Headset	SPKR button Select	Gain
1	Yes	Yes	No	1:1(fixed)
2	No	Yes	Yes	1:1(fixed)
3	No	Yes	No	Adjustable
4	No	Yes	No	1:1(fixed)
5 (jack)	No	Yes	No	1:1(fixed)

Table 2-2 Unswitched input table

Unswitched #2, J1 pin 44 is unswitched audio that is always connected to the Pilot's headphone. However, this unswitched audio is only presented to the aircraft speaker when the SPKR push button has been selected.

The audio low for unswitched #4 (J2, pin 15) should be connected to a convenient audio low. However, this should NOT be connected to Music Low.

Unswitched #1 is presented to the pilot headphone in fail-safe (off) mode.

NOTE

AMX240 Audio Panel Installation Manual

Inputs 1, 2 and 4 are fixed (1:1), and any audio level adjustments must be made at the input source. Unswitched #3 has a variable adjustment control located on the bottom side of the unit. This control allows you to adjust the volume level of that unswitched input. Refer to Adjustments § 2.7.

The front panel jack can be configured to act as a fifth unswitched input. When configured through the front panel function switches (see operational section), the audio input to this jack will be presented to the pilot and copilot headsets, and not muted.

NOTE

The front-mounted utility jack is intended for portable equipment that is advisory in nature. It is NOT INTENDED for use as a primary warning channel. Audio of importance MUST ALWAYS be hard-wired into the unswitched inputs of the audio panel.

2.4.7 "Swap" Mode

When a momentary, normally open, push-button switch is connected between pin 20 on the J2 connector and aircraft ground, the user can switch between COM 1 and 2 by depressing this switch without having to turn the mic selector switch. This yoke-mounted switch eliminates the need to remove your hands from the yoke to change transceivers. The transfer of MIC indication from COM 1 to COM 2 shows that the swap has been initiated; there is no dedicated swap indicator.

2.4.8 TEL (Duplex) Function for Cell Phones

Audio streams selected by the intercom mode are provided to the Tel output, and audio from Tel is presented to the headset. This allows a telephone-like audio interface.

The TEL mode in the AMX240 is compatible with many cellular telephones with hands-free headset interfaces. The front panel 3/32" utility jack can be used as the interface to the Cell Phone, or a jack can be installed somewhere on the aircraft panel. The wired interface jack is connected with the AMX240 as shown:

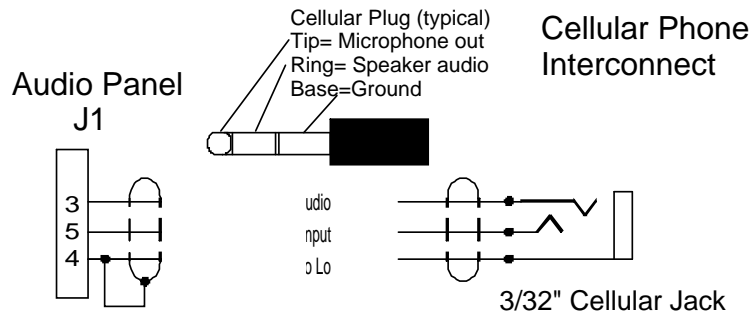

**This is a typical interconnect
Avidyne does not guarantee
compatibility in all cases.**

Figure 2-1 Cellular telephone interface for rear connector, if an additional jack is desired

The AMX240 is compatible with most Bluetooth® enabled devices for making and receiving telephone calls through the aircraft audio system.

2.4.8.1 Cell phone Sidetone

As shipped from the factory, the AMX240 provides cellular telephone sidetone (the user's voice fed back to the headset). Some cell phones do provide sidetone. Telephone sidetone can be disabled by pressing the NAV 2 button for more than one second when power is on.

NOTE

Unauthorized use of unapproved cellular telephone devices in aircraft is subject to FCC enforcement action, which may include a \$10,000 fine per incident.

FCC Regulation 47 CFR § 22.925 *Prohibition on airborne operation of cellular telephones.*

AMX240 Audio Panel Installation Manual

Cellular telephones installed in or carried aboard airplanes, balloons or any other type of aircraft must not be operated while such aircraft are airborne (not touching the ground). When any aircraft leaves the ground, all cellular telephones on board that aircraft must be turned off.

Avidyne Corporation. does not endorse using unapproved cellular telephone equipment in flight, and takes no responsibility for the user's action.

2.4.9 Public Address Mode

By holding SPKR pushbutton for more than 2 seconds, the AMX240 will be placed into public address (PA) mode. In this mode, the pilot will be talking over the cockpit speaker when he presses his PTT switch. Copilot will still continue on the selected COM radio. The SPKR label will blink green when the PA is on.

To deselect the PA, either press the SPKR for more than 2 seconds or just simply cycle power on the audio panel.

When the discrete Output is enabled, J2 Pin 19 will go low when in PA mode, providing a logic level that can be used to incorporate a speaker-switching scheme. This 50 mA circuit (10 Ω) can control a switching means such as a relay that would transfer the speaker output amplifier from the cockpit speaker to drive another cabin speaker. If the PA mode is used with a microphone in proximity to an active cockpit speaker, feedback might result.

To *enable* the PA discrete Output located at the rear connector, the internal configuration jumper, J4, **MUST** be placed across both pins in the header. This jumper is shipped as open from the factory.

2.4.9.1 Public Address Output Jumper

1. Remove qty. 4 Phillip head screws from the unit. **NOTE: THE SCREW IN THE REAR OF THE PANEL IS A DIFFERENT LENGTH THAN THE OTHER FOUR. YOU MUST PUT THE SHORTER LENGTH SCREW BACK IN THE SAME LOCATION OR DAMAGE WILL OCCUR.** See Figure #1.

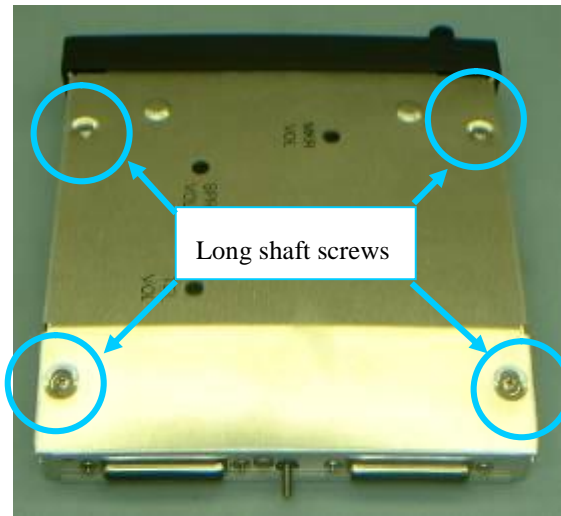

Figure 2-2 Screw Locations

2. Move the blue jumper located in the back corner near the sub-D connectors on *both* pins of J4. See Figure #2-3.

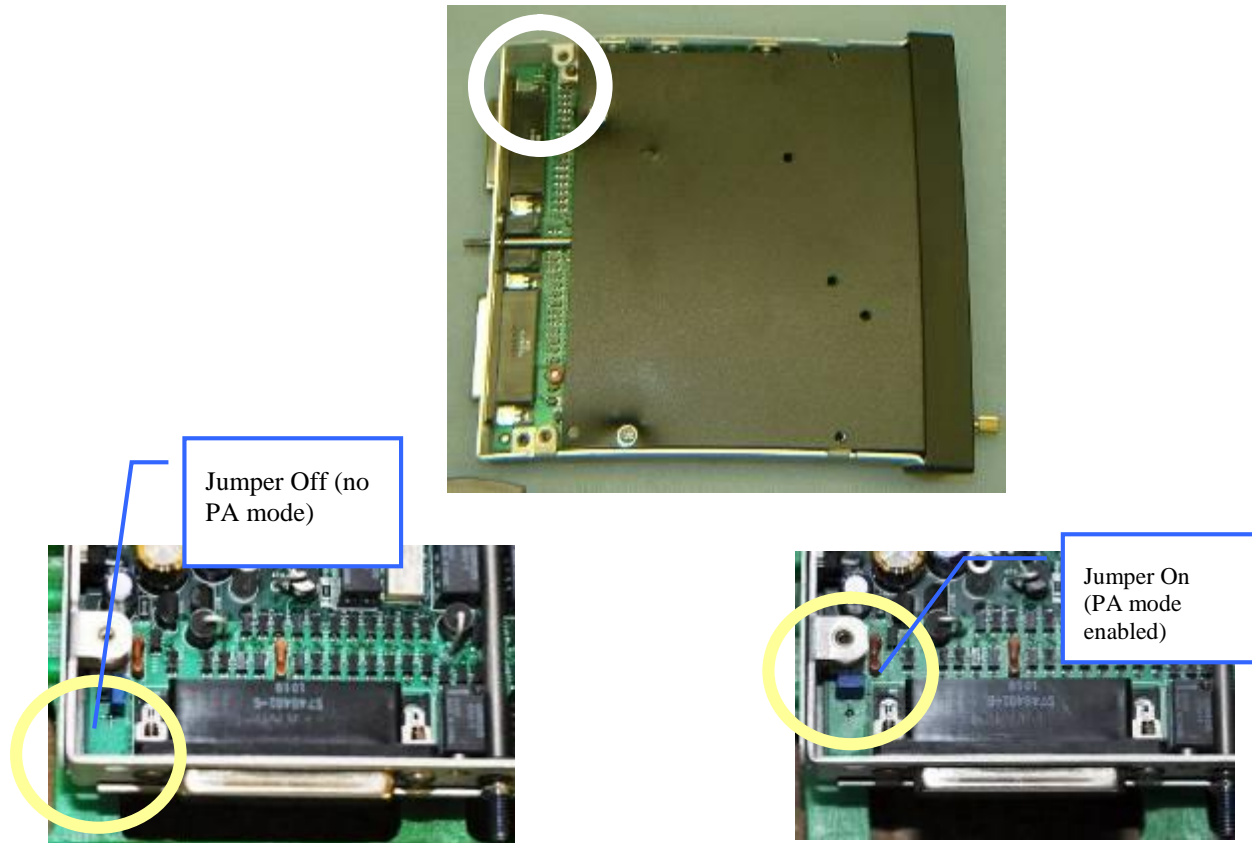

Figure 2-3 Jumper Location

4. Place the lid back on the unit, aligning holes.
5. Install and tighten qty. 4 long thread screws into the lid, and **one short screw on the rear**.

2.4.10 PA Mute (J2, Pin 12)

Pin 12 of J2 is a TTL logic *output* that is pulled low during PTT operation.

2.4.11 Split/COM 2 select

Pin 24 and Pin 25 on the J1 connector are used by the Avidyne R9 Integrated Flight Display System and should be connected per the R9 installation manual.

2.5 Intercom wiring

See Appendix C and D for intercom connection configurations. It is critical to the proper operation of this system to have this connector wiring made in accordance with these diagrams. Use 2- and 3-conductor, MIL-spec cable as shown. Connect the shields at the audio panel end only, and tie to the audio low inputs as shown.

2.5.1 Entertainment Inputs

The AMX240 has two INDEPENDENT music inputs, PLUS a front mounted jack that is connected to Entertainment 1. Entertainment input number 1 is J2 pins 23 (left channel) and 24 (right channel), with respect to pin 25, and Entertainment number 2 is connected to 26 (left channel), 27 (right channel), with respect to 28.

AMX240 (050-890-0240) has wireless connectivity to stream music from a paired Bluetooth device. This stream is distributed as Music 1. Refer to [§3.11](#) for more information.

NOTE

AMX240 Audio Panel Installation Manual

Use the low level output of any additional entertainment device to connect to the audio panel. Maximum signal level is **3 VAC** p-p. **DO NOT** use a speaker-level output, this will cause internal damage in the audio panel.

2.5.2 Entertainment muting

The AMX240-system incorporates a "Soft Mute™" system. This will mute the entertainment devices during ICS and/or radio conversation. See [Section 3.8](#) for more information.

Press the Music switch to disable crew SoftMute™. Turning down the entertainment volume allows the pilot to place the entertainment into the background while having the radios in the foreground and eliminates the constant interruption of the music while still keeping the radios a priority.

CAUTION

Local oscillators and internal signals from entertainment equipment can cause undesired interference with other aircraft systems. Before takeoff, operate the entertainment devices to determine if there is any adverse effect within the aircraft systems. If any unusual operation is noted in flight, immediately switch off the entertainment devices.

All additional entertainment devices must be switched off for both takeoff and landing.

2.5.2.1 Entertainment 2 Mute

Entertainment 2 is always in Karaoke mode- and will not be muted by any other audio.

2.5.3 Configuring Music Input with Function Keys

The music inputs can be configured by the user from the front panel (see section 3.8). There are two configurations available, independent, and single input (music 1 to all stations).

If the inputs are independent, Input #1 (or the front jack) is provided to the pilot and copilot. Muting (SoftMute™) is controlled by the front panel "mute" button. Music 2 is provided to the passengers at all times and does not mute.

If the single-source mode is activated through the function keys ("Music 1 all headsets"), rear connector music 1 or Bluetooth streamed music is connected to all intercom positions. Muting is controlled by the front panel.

2.5.3.1 Annunciation and recorder playback

The pilot and copilot will hear the Function Key annunciations and digital recorder playback audio.

2.5.4 Playback button Installation

Internal Recorder can be played back from the front panel (**REPLAY**). A remote momentary, normally open (NO) push button switch may be installed if desired to remotely activate the Recording System playback. This switch can be located anywhere in cockpit convenient to the pilot's reach. The NO switch should be connected to pin 22 of J2 (Playback) of the AMX240, and ground. When installed, this button will act as in § 3.13.

Pressing the front panel REPLAY or MUTE switch will stop the recorder playback.

2.6 Marker Beacon Installation

2.6.1 Marker Antenna Installation

A marker beacon antenna, appropriate to the type and speed of the aircraft, is required (not included). Refer to aircraft and antenna manufacturer's installation instructions, as well as AC43.13-2B (or later revision), Chapter 3, for information on proper antenna installation techniques. The marker beacon antenna must be mounted on the bottom of the aircraft.

2.6.2 External Marker Lights

For installations that require external marker beacon lights, there are three outputs that can drive 12-Volt lamps only. The external output lamps are driven high (typically +7.0 VDC ±4.0 VDC unloaded, at MAX brightness) when active. Maximum source current per lamp is 125 mA. Voltage varies with aircraft panel light dimming.

2.6.3 Middle Marker Sense

A Middle Marker Sense output signal is available from the AMX240 to certain flight control systems. This function will not operate during the test mode. This output will go to +4.5 VDC (± 1.0 VDC) when a valid Middle Marker signal is received. This output is J1, pin 39.

2.7 Adjustments

The AMX240 is factory adjusted to accommodate the typical requirements for most aircraft configurations. There are three adjustments in the top cover that allow the installer to tailor the specific functions.

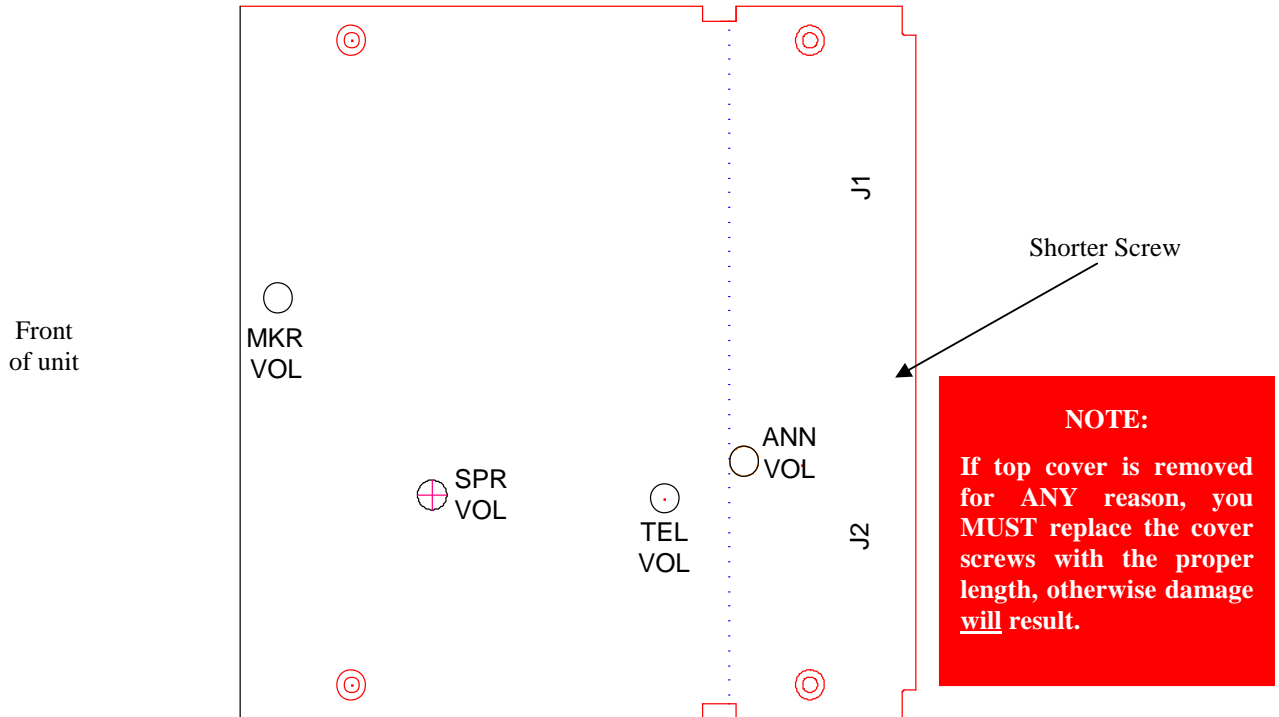

Figure 2-4- AMX240 Adjustments, top cover

- Speaker Volume- Turn adjustment clockwise to increase cabin speaker output.
- Marker Beacon Volume, turn adjustment counterclockwise to increase marker beacon audio level.
- TEL volume, turn adjustment Clockwise to increase the incoming telephone audio.
- ANN VOL Function Mode Annunciation Volume – controls the level of the to access voice annunciations contained in the unit. (Top cover must be removed).
- Unswitched Input 3 Volume, adjust from 50% to 200% of input value. (Bottom cover must be removed).

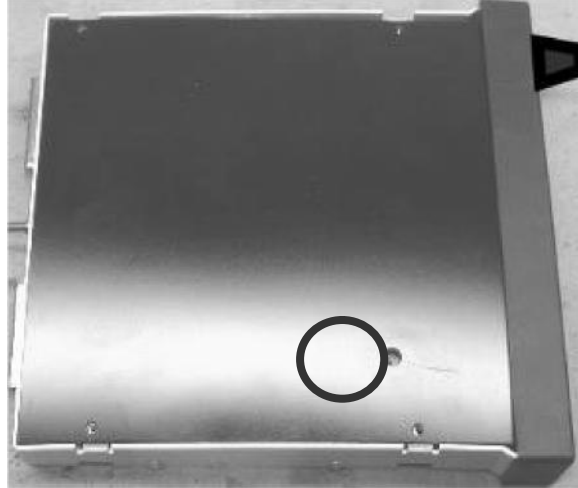

Figure 2-5 – Unswitched 3 Audio Level (bottom cover removed)

2.8 Communications Antenna Installation Notes

For best results while in Split Mode, it is recommended that the one VHF communications antenna is located on top of the aircraft while the other communications antenna is installed on the bottom. Any antenna relocation must be accomplished in accordance with AC 43.13-2B, aircraft manufacturers' recommendations and FAA-approved technical data.

WARNING

It is probable that radio interference will occur in the split mode when the frequencies of the two aircraft radios are adjacent, and/or the antennas are physically close together. **Avidyne makes no expressed or implied warranties regarding the suitability of the AMX240 in Split Mode.**

2.9 AMX240 Pin assignments

J1	Function	J2	Function
1	Marker Antenna	1	Pilot Phones Lo
2	Marker Ant Lo	2	Copilot Phones Lo
3	TEL Audio in	3	Copilot Phones (L)
4	TEL Audio Lo	4	Copilot Phones (R)
5	TEL Mic Audio	5	Lights lo
6	TEL Mic Key (not used)	6	14/28 V Lights
7	MON 1 Audio In	7	14/28 V Lights
8	MON 1 Audio Lo	8	Aircraft Power
9	Com 1 Audio	9	Aircraft Power
10	Com 1 Audio Lo	10	Aircraft Ground
11	Com 1 Mic	11	Aircraft Ground
12	Com 1 Mic Key	12	PA Mute
13	Com 2 Audio	13	MKR HI sense
14	Com 2 Audio Lo	14	MKR HI sense lo
15	Com 2 Mic	15	Unswitched Audio #4
16	No Connect	16	Pilot Phones (L)
17	Nav 1 Audio	17	No Connect
18	Nav 1 Audio Lo	18	No Connect
19	Nav 2 Audio	19	PA Enable
20	Nav 2 Audio Lo	20	Swap
21	MON 2 Audio	21	Swap Lo
22	MON 2 Audio Lo	22	Playback
23	No Connect	23	Music 1 (L)
24	Split COM Select	24	Music 1 (R)
25	COM 2 Select	25	Music 1 Lo
26	No Connect	26	Music 2 (L)
27	16 ohm COM load	27	Music 2 (R)
28	16 ohm COM load lo	28	Music 2 Lo
29	Unswitched Audio #3	29	MUTE discrete output
30	Com 2 Mic Key	30	No connect
31	Unswitched Audio #1	31	Pilot Phones (Rt)
32	Unswitched Lo	32	Copilot Mic Audio
33	Pilot Mic Audio	33	Copilot Mic PTT
34	Pilot Mic PTT	34	Copilot Mic Lo
35	Pilot Mic Lo	35	Pass 1 Mic Audio
36	Ext IM MKR	36	Pass 1 Mic Audio Lo
37	Ext OM MKR	37	Pass 2 Mic Audio
38	Ext MM MKR	38	Pass 2 Mic Audio Lo
39	MM Sense	39	Pass 3 Mic Audio
40	Pass HP (L)	40	Pass 3 Mic Audio Lo
41	Pass HP (R)	41	Pass 4 Mic Audio
42	Pass HP Lo	42	Pass 4 Mic Audio Lo
43	Unswitched 2 Lo	43	Speaker Lo
44	Unswitched Audio #2	44	Speaker Output

2.10 Wiring Checkout

After wiring is complete, verify power is ONLY on pins 8 and 9 of the J2 and airframe ground on connector pins 10 and 11. Failure to do so will cause serious internal damage and void Avidyne's warranty.

2.11 Unit Installation

To install the AMX240, gently slide the unit into the mounting rack until the hold-down screw is engaged. While applying gentle pressure to the face of the unit, tighten the 3/32" hex-head in the center of the unit until it is secure. **DO NOT OVER TIGHTEN.**

CAUTION

Apply steady pressure to the bezel while screwing the unit into the tray to ensure even seating of the unit and connectors. **WARNING** Do not over-tighten the lock down screw while installing the unit in tray. **Internal damage will result.**

2.12 Operational Checkout

2.12.1 Required Test Equipment

In order to return an aircraft to service after installation of the AMX240, the installer must have access to a Marker Beacon signal generator:

- a. IFR NAV401L, NAV402AP, IFR4000
- b. TIC T-30D, T-36C

Equivalent test equipment is acceptable as long as the testing requirements can be met.

2.12.2 Audio Panel Test

NOTE

The *IntelliVox*® is designed for ambient noise levels of 80 dB or above. Therefore some clipping may occur in a quiet cabin, such as without the engine running, in a hangar. This is normal.

1. Apply power to the aircraft and avionics.
2. Plug headsets into the pilot, copilot, and occupied passenger positions.
3. Verify fail-safe operation by receiving and transmitting on com 1 from the pilot position, with the audio panel power off. The COM audio will be present in one ear cup only.
4. Switch on the unit by pressing the volume (VOL) knob.
5. Check intercom operation.
6. Push the COM 1 Xmt select button (lower row).
7. Verify that both of the **COM 1** buttons light. Verify that transmit button LED (Light Emitting Diode) near the mic selector is not blinking. If the LED is blinking, stop testing and troubleshoot the microphone PTT installation.
8. Verify proper transmit and receive operation from the copilot position, noting that the copilot PTT switch allows proper transmission on the selected transceiver. Verify that the COM 1 Xmt button blinks when transmitting.
9. Verify that pushing the **COM 2** button causes the button to illuminate, and the COM 2 receiver to be heard. Verify operation on COM 1 from the pilot position.
10. Repeat for COM 2
11. Press and hold the COM 1 Xmt button. While holding the COM 1 button, press the COM 2 Xmt button. This places the unit in "split Mode;" Verify that the pilot can transmit and receive on COM 1, while the copilot transmits and receives on COM 2.
12. Verify proper operation of all receiver sources by selecting them using the appropriate button. The button illuminates to show which source is in use.
13. Push the SPKR button. Verify that all selected audio is heard in the cockpit speaker. Verify that the audio mutes when the mic is keyed.
14. Verify that the appropriate LED in the lower button row blinks when either push to talk is keyed.
15. Verify proper Intercom system operation in the **ALL**, **ISO** and **CREW** modes (see Table 3-1).

16. Verify that the audio selector panel system does not adversely affect any other aircraft system by systematically switching the unit on and off, while monitoring the other avionics and electrical equipment on the aircraft.

2.12.3 Marker Checkout

1. Connect a ramp generator at the antenna end of the marker coax. With the unit under test in HI sensitivity, verify that a 160 μ V, modulated 95% with 1300 Hz, signal will illuminate the amber (M) marker light, and that marker audio is present in the headphones when the Marker Audio (MKR) push-button has been depressed. Select SPKR for speaker to verify marker audio availability on the cabin speaker. Verify that the white (I) and blue (O) lights will illuminate within \pm 3dB of the amber lamp, with 3000 HZ and 400 Hz applied, respectively.
2. Repeat with the unit in LOW sensitivity, with 430 μ Volts applied.
3. Connect the marker antenna and verify proper operation.

2.12.4 TEL Checkout

Press the TEL button. Verify that the pilot headset is connected to the cellular telephone system (if installed). Verify that by using the pilot side PTT, the pilot can transmit on the other selected radio (COM 1 or COM 2). The telephone function will allow any person heard by the pilot on the intercom, also heard on the telephone.

2.12.4.1 Bluetooth Checkout

Verify that the AMX240 will “pair” with a Bluetooth device, and interface with cellular phone and Music source. See section 3.11 for more information.

2.12.5 Internal Recorder Checkout

With headset plugged into pilot’s side jacks, tune COM 1 to local frequency, such as FSS or ATC ground. Select COM 1 on mic selector switch, and record several incoming radio transmissions.

Press the REPLAY, this action will then automatically play back the last recorded message. Press and HOLD the button again to stop the play back, and then momentarily press again to play prior messages.

This audio should appear in the pilot and copilot headsets, and only be incoming transmissions from the transceiver selected in the mic select switch. Depress the audio panel or yoke mounted playback switch, and verify that messages play, in the order received. Repeat for COM 2. The playback will be stopped by audio on the selected com. The message can be replayed from the beginning, and audio received during the playback will not be stored.

2.13 Final Inspection

Verify that the wiring is bundled away from all controls and no part of the installation interferes with aircraft control operation. Move all controls through their full range while examining the installation to see that no mechanical interference exists. Verify that the cables are secured to the aircraft structure in accordance with good practices, with adequate strain relief. Ensure that there are no kinks or sharp bends in the cables and coaxial cables. Verify that the cables are not exposed to any sharp edges or rough surfaces, and that all contact points are protected from abrasion.

Complete documentation that may be required, such as a logbook entry, weight and balance computation and FAA Form 337. Sample text for FAA Form 337, and instructions for continuing airworthiness can be found in Appendix F. Return completed warranty registration application to Avidyne, or complete online at www.avidyne.com.

Section III OPERATION

3.1 SCOPE

This section provides detailed operating instructions for the Avidyne AMX240, Audio Selector Panel/Marker Beacon Receiver/Intercom Systems. Please read it carefully before using the equipment so that you can take full advantage of its capabilities.

This section is divided into sections covering the basic operating areas of the AMX240 systems. They are Communications Transceiver Selection, Audio Selector, Intercom, Marker Beacon Receiver and special functions, including the Bluetooth® functionality in the AMX240.

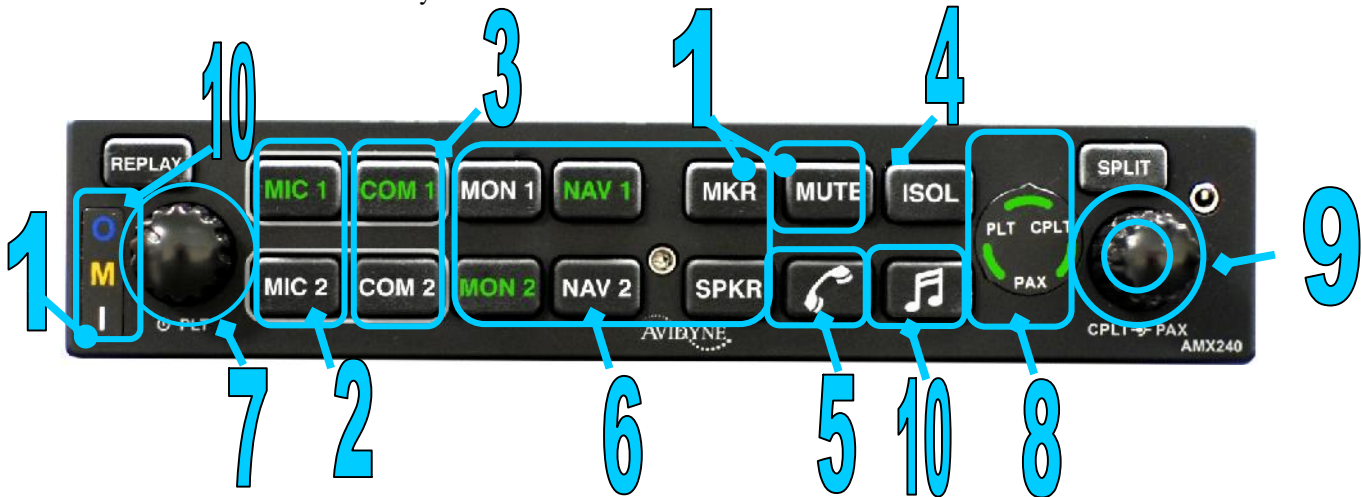

Figure 3-1 AMX240 Operating Controls

Unit power is turned on by turning the left side volume knob clockwise. When the knob is fully counterclockwise, the AMX240 is OFF or "Fail-Safe" position, the pilot headset is connected directly to COM 1 as well as unswitched input #1. This allows communication capability regardless of unit condition. Any time power is removed or the unit is turned OFF, the audio selector will revert to fail-safe mode.

The power switch controls all audio selector panel functions, intercom and marker beacon receiver. All pushbutton selections will be remembered and return to the last state when turned on.

3.2 Communications Transmit (XMT) (2) and Receive Selection (3)

There are two pushbuttons associated with the transmitter selection. The MIC1 and MIC2 buttons (# 2) control which transceiver is selected for transmit. The COM1 and COM2 pushbuttons (# 3) allow selection of the receiver audio. Push the MIC button to select the desired COM transmitter.

The AMX240 has an automatic selector system. Audio from the selected transceiver is automatically heard in the headsets and speaker (if selected). You can check this function by switching from one transmitter to the other transmitter by pressing the MIC2 transmitter selector pushbutton. See that the associated receiver pushbutton indicator light turns green. This guarantees that the pilot will *always* hear the audio from the transceiver selected for transmit.

The AMX240 "remembers" the receiver selection, so that when switching transmitters from MIC 1 to MIC 2, if COM 2 audio was previously selected, COM 1 audio will continue to be heard. This eliminates the pilot having to switch the audio back on, after changing transmitters.

When switching from MIC 1 to MIC 2 while COM 2 was not previously selected, COM 1 audio will be switched off. In essence, switching the mic selector will not override prior selection of COM receiver audio.

In normal (not split) modes, the AMX240 gives priority to the pilot's radio Push-To-Talk (PTT). If the copilot is transmitting, and the pilot presses his PTT, the pilot's microphone will be heard over the selected com transmitter.

In TEL () mode, the pilot microphone and headphones are connected to the cell phone. The pilot PTT will switch the pilot mic to the selected com transceiver, and allow continued aircraft communications to continue. (See Section

AMX240 Audio Panel Installation Manual

3.4 —TEL—for more details)

The copilot will also be able to transmit on the other selected radio with his PTT as well.

3.2.1.1 Split Mode

The split mode can be activated at any time by pressing the **SPLIT** button. This places the pilot on MIC 1 and the Copilot on MIC 2.

Pilot on MIC 2 and Copilot on MIC 1 is not possible.

NOTE

Due to the nature of VHF communications signals, and the size constraints in general aviation aircraft, it is probable that there will be some bleed-over in the Split mode, particularly on adjacent frequencies. Avidyne makes no warranty about the suitability of Split Mode in all aircraft conditions.

The pilot shall hear other selected navaid and unswitched audio; the copilot shall only hear COM 2 and unswitched audio.

When the Split mode is active, the intercom shall enter the ISO mode. In SPLIT mode, no LED arc segments are lit.

Pressing ISOL shall re-enable intercom for CREW during SPLIT mode and shall light up appropriate segments.

To exit the split mode, push MIC 1 or MIC 2 as desired to put both crewmembers on the desired transceiver.

3.2.1.2 Swap Mode (Switch from MIC 1 to MIC 2 remotely)

With a yoke mounted, normally open momentary switch, the pilot can change from the current COM transceiver to the other by depressing this switch. To cancel "Swap Mode," the pilot may either press the yoke mounted switch again, or select a different COM with the MIC buttons.

3.2.2 Transceiver MONitor (6)

MON 1 and MON 2 buttons allows the crew to listen to the standby frequency in the Avidyne #1 or #2 R9 IFDs. Alternatively, MON1 and MON2 can be used to listen to DME and/or ADF audio.

3.3 NAV Audio Selector (6)

Navigation receiver audio is selected through four momentary, push-button, backlit switches.

The users can identify which receivers are selected by noting which switches are green. Navigation aid audio push buttons are labeled **NAV 1**, **NAV 2**, and **MKR** (Marker). When one of these buttons is pressed, the mode is active, and the LED will illuminate. Press the switch again and it will be "off" and remove that receiver from the audio output.

In SPLIT mode, only the pilot will hear selected navigation audio.

3.4 Telephone (TEL) (5)

The TEL mode (**T**) serves as a full duplex interface and distribution for telephone systems such as portable cellular phones with earpiece jacks, and Bluetooth® enabled telephones. Pressing the (**T**) button activates the telephone mode.

This connects the telephone to the users as follows:

In **ALL** intercom mode, all crew and passengers will be heard on the phone when they speak. COM and other selected radio audio is also heard in the headsets. If the pilot or copilot pushes the radio PTT, their mic will be transferred to the selected COM radio. The telephone party will not hear ATC communications, and vice versa.

In **CREW** mode, only the pilot and copilot are connected to the telephone. Passengers will not hear the telephone. The pilot and copilot will also have transmit capability on the other selected transceiver.

In **ISO** intercom mode, when the AMX240 is in the **TEL** mode, the pilot position is in the "Phone Booth." Only the pilot will hear the telephone, and only he will be heard. He will also have access to COM 1 or 2, and will transmit on that radio using the PTT. All selected audio is provided to the pilot.

NOTE

Because the cell-phone uses an intercom circuit, all stations on that circuit will lose intercom capability when the cell phone is in use.

3.4.1 Cell phone Sidetone

As shipped from Avidyne, the AMX240 provides cellular telephone sidetone (the user's voice fed back to the headset). Some cell phones provide sidetone. In AMX240 audio panels, Telephone sidetone can be disabled by holding the (Nav 2) button for more than one second when power is on.

3.5 Speaker Amplifier (6)

SPKR stands for speaker. This switch will place all selected audio on the cockpit when this switch is selected. Except for certain unswitched audios, the speaker amplifier is not active in the "Split Mode".



speaker
fier is not

Depending on installation, important audio annunciations such as radar altimeter or autopilot disconnect will come over the speaker even if it is not selected, while other unswitched, but muted inputs, such as GPS alerts, will only be present if the SPKR button is selected. Consult your professional avionics installer for these important configuration details.

3.5.1.1 Public Address Function

To access PA function, hold the SPKR button for more than one second. The pilot microphone will be heard on the speaker when the pilot PTT is used. The copilot can continue to use the selected com radio while the pilot will now be heard over the speaker. During Public Address, the **SPKR** button will flash. To exit PA mode, push **SPKR** again for more than one second or simple cycle power on the audio panel.

Note: To address all passengers and crew, we recommend putting the audio panel intercom in "ALL" mode, when making a PA announcement.

3.6 Marker Beacon Operation (1)

The Marker Beacon Receiver uses visual and audio indicators to alert you when the aircraft passes over a 75 MHz transmitter.

The Blue lamp, labeled "O", is the Outer Marker lamp and has an associated 400-Hertz 'dash' tone. The lamp and tone will be keyed at a rate of two tones/ashes per second when the aircraft is in the range of the Outer Marker Beacon.

The Amber lamp, labeled "M", is the Middle Marker lamp and is coupled with a 1300 tone. It is keyed alternately with short 'dot' and long 'dash' bursts at 95 combinations per minute.



Hertz
per mi-

The White lamp, labeled "I", is the Inner marker and has a 3000 Hertz 'dot' tone. The lamp and tone will be keyed at a rate of six times per second.

The audio from the Marker Beacon Receiver can be heard by selecting the "MKR" button switch. To adjust the volume level, there is a service adjustment located on the unit.



push-
top of the

Holding the MKR button for one second activates marker lamp test, and illuminates lamps simultaneously to assure the lamps (internal and external) are in working order. not activate MM autopilot sense output.

all three
TST does

Pressing the MUTE button while the beacon audio is active will mute the audio until the next beacon is received.

An external switch pushbutton is used to set the receiver sensitivity. Default is "Low" sense.

3.7 Intercom Operation

3.7.1 IntelliVox® VOX-Squelch

No adjustment of the *IntelliVox*® squelch control is necessary. There is no field adjustment. Through three individual signal processors, the ambient noise appearing in all six microphones is constantly being sampled. Non-voice signals are blocked. When someone speaks, only their microphone circuit opens, placing their voice on the intercom.

The system is designed to block continuous tones; therefore people humming or whistling in monotone may be blocked after a few moments.

AMX240 Audio Panel Installation Manual

For consistent performance, any headset microphone **must** be placed within ¼-inch of your lips, preferably against them. (ref: *RTCA/DO-214, 1.3.1.1 (a)*).

NOTE

It is also a good idea to keep the microphone out of a direct wind path. Moving your head through a vent air stream may cause the *IntelliVox*® to open momentarily. This is normal.

The *IntelliVox*® is designed to work with normal aircraft cabin noise levels (70 dB and above). It loves airplane noise! Therefore, it may not recognize speech and clip syllables in a quiet cabin, such as in the hangar, or without the engine running. This is normal.

For optimum microphone performance, Avidyne recommends installation of a Microphone Muff Kit from Oregon Aero (1-800-888-6910). This will not only optimize VOX performance, but will improve the overall clarity of *all* your communications.

Manufacturer	Model	Mic Muff™ Part Number
Bose	Dynamic	90010
	Electret	90015
	M87 Dynamic	90020
David Clark	H10-30	90010
	H10-20, H10-40	90015
	H10-13.4	90015
Lightspeed	All	90015
Peltor	7003	90010
	7004	90015
Pilot	11-20 & 11-90	90015
Sennheiser		90015
Telex	Airman 750, Echelon	90015
	AIR3000	90010

Table 3-1 Mic Muff™ Part Numbers

3.7.2 Intercom Volume Control (7 & 9)

The left volume control knob adjusts the loudness of the intercom for the pilot. It has no effect on selected radio levels, music input levels or copilot and passengers' volume level.

The right side, inner volume control knob controls intercom volume for the copilot and the outer knob the passengers' volume. It has no effect on radio or music levels.

Adjust the radios and intercom volume for a comfortable listening level. Most general aviation headsets today have built-in volume controls; therefore, volume also can be further adjusted at the individual headset.

3.7.2.1 Mono headsets in Stereo Installation

The pilot and copilot positions work with stereo or mono headsets. All passenger headsets are connected in parallel. Therefore, if a monaural headset is plugged in to a AMX240 Stereo installation, one channel will be shorted. Although no damage to the unit will occur, all passengers with stereo headsets will not hear one channel, unless they switch to the "MONO" mode on their headset.

3.7.3 Intercom Modes (4)

The "ISOL" pushbutton switch on the right side of the panel provides the selection of the three intercom modes. The description of the intercom mode function is valid only when the unit is not in the "Split" mode.

This button cycles through the intercom modes, green LED arcs show which mode is currently active.



The ISOL key selects the intercom mode. It has three states: **pilot isolate**, **all**, and **crew**.

A. In **All**, all three LED segments shall be lit



All Intercom mode

B. In **Crew**, the LED segment connecting PLT and CPLT shall be lit



Crew Intercom Mode

C. In **Pilot isolate**, the LED segment connecting CPLT and PAX shall be lit



Pilot **ISOL**ate mode

D. In **SPLIT** mode, no LED segments are lit.



SPLIT Mode (when activated)

Pressing ISOL button shall re-enable intercom during SPLIT mode and light up the CREW Mode-B segment.

3.8 Music and Music Muting (10)

The AMX240 has two independent music inputs at the rear connector, and a front panel jack. The AMX240 also has the ability to receive streaming music from a Bluetooth-enabled device.

Music 1 will be heard by the pilot and copilot positions. Music 1 can also be distributed to the passengers by holding the Music button for more than one second.

NOTE:

All music devices should be turned off for take off, landing, or any critical phase of flight. FAA Regulation 14 CFR 91.21 restricts the use of portable electronic devices.

§91.21 “(a) Except as provided in paragraph (b) of this section, no person may operate, nor may any operator or

AMX240 Audio Panel Installation Manual

pilot in command of an aircraft allow the operation of, any portable electronic device on any of the following U.S.-registered civil aircraft. . .

“(b)(5) Any other portable electronic device that the operator of the aircraft has determined will not cause interference with the navigation or communication system of the aircraft on which it is to be used.”

You can refer to Advisory Circular 91.21-1A for more information, at <http://www.faa.gov>

The front panel "Mute" button has **two** modes, and controls the Mute function for Music 1.

The music can be muted by both the radio and the intercom, or, in the MUTE button is pushed (MUTE indicator on), the intercom conversation will **not** mute the Music.

At power up, the music will always be muted.

Music	Intercom	Radio	LED
Mute On	Muted	Muted	White
Mute Off			Green

Passenger's music 2 hardwired music input shall always be in Karaoke mode, disabling the music muting isn't available.

3.8.1 Music in Pilot ISO mode (8)

If desired, the pilot can elect to hear Music #1, in the ISO mode. While the intercom is in ISO mode (no top arc lit), push the ISOL and hold for one second. This mode will be indicated by the Pilot LED arc blinking slowly (once in every 5 seconds). The pilot will now hear Music #1, and it will mute in accordance with the Mute mode as described in §3.8.

3.9 Telephone Mode (5)

Warning:

United States FCC Regulations contained in 47 CFR § 22.925 contain prohibition on airborne operation of cellular telephones. “Cellular telephones installed in or carried aboard airplanes, balloons or any other type of aircraft must not be operated while such aircraft are airborne (not touching the ground). When any aircraft leaves the ground, all cellular telephones on board that aircraft must be turned off.”

The TEL mode serves as a full duplex interface for telephone systems such as portable cellular phones with earpiece jacks (or Bluetooth connectivity (AMX240 only). When interfaced with an approved airborne telecommunications system, the AMX240 can serve as a audio control and distribution center.

In intercom **ALL** mode, crew and passengers will be heard on the phone when they speak. All will hear selected audio. COM audio is automatically heard in the headsets.

In **CREW** mode, the pilot and copilot are connected to the telephone. The pilot and copilot will have transmit capability on the other selected transceiver COM 1 or 2, simply by using their respective PTT switch.

In intercom **ISO** mode, when the AMX240 is in the **TEL** mode, the pilot position is in the "Phone Booth." Only the pilot will hear the telephone, and only he will be heard. He will also have access to COM 1 or 2, and will transmit on that radio using the PTT. All selected audio is provided.

NOTE

Because the cell phone uses an intercom circuit, all stations on that circuit will lose intercom capability when the cell phone is in use. Intercom conversations will still be present if the cell phone provides sidetone, or if the audio panel is modified for telephone sidetone.

Avidyne does not guarantee compatibility with personal cellular telephones.

AMX240 Audio Panel Installation Manual

3.9.1 Cellular telephone sidetone

As shipped from the factory, the AMX240 provides cellular telephone sidetone (the user's voice fed back to the headset). Some cell phones already provide sidetone. In AMX240 Telephone sidetone can be disabled by pressing the NAV 2 button for more than one second.

3.10 Utility Jack

The 2.5-millimeter (3/32") jack on the front of the AMX240 has three distinct functions:

- Cell phone input
- Advisory audio input
- Music input

The use of this jack is controlled by three Smart Function Keys (SFK) controlled from the front panel. See Section 3.11 — Smart Function Keys.

3.10.1 Cellular phone

When a cellular telephone is connected to this jack, the AMX240 audio panel will connect the intercom to the cell phone when the TEL (J) button is pressed (5), and behave as described in section 3.4. The telephone ringer, if present, will be heard unless the input is muted by other radio or intercom.

3.10.2 Audio Advisory Input

The front jack can be used as a priority advisory input for auxiliary systems such as a GPS terrain advisory or portable traffic watch system. To prevent radio or intercom from muting this input, press the "Music Symbol (10)" button.

3.10.2.1 Smart Jack Function

When the AMX240 has a signal on music #1 input coming in from the rear connector, the front panel jack automatically becomes a Priority Advisory input, and is heard in the crew headphones.

NOTE

The front jack is no substitute for the certified installation of alerts such as the GPS waypoint or autopilot tones. These still must be hard wired into the back by your installer. The front jack input **will be muted** by radio or intercom unless music is *actively playing* in the rear connector.

3.10.3 Music Input

When used as a music input, the front panel jack is treated as Music #1. However, thanks to the function controls, it can be distributed to all users, depending on the intercom mode.

3.11 Bluetooth® interface

The AMX240 has a Bluetooth interface. The audio panel is always "discoverable," so you need to search for the AMX240 from your Bluetooth-equipped phone or music source. The access code is 0000, if needed. Once the AMX240 has been "paired" with your Bluetooth



just default device,

the TEL distribution will act as described in § 3.4. You can answer a call by pushing the [J] button while it is ringing. Calls can be answered from the telephone handset or the audio panel. You can disconnect from either the handset or the audio panel. When a call is disconnected or dropped, the [J] button indicator will change to white after a few moments.

3.11.1 Pairing and unpairing Bluetooth devices

The AMX240 can be paired with up to eight individual devices. When that number is exceeded, one device will be automatically un-paired to allow the new device. The device eliminate will be selected at random by the Bluetooth module. *Hint, if your old phone is not recognized by the AMX240, you may simply need to reset the Bluetooth. With the AMX240 turned off, push and hold the NAV 1 and MKR buttons. Turn the AMX240 on. You should hear a tone beep in the headset, indicating the successful reset of the Bluetooth interface. You will need to re-pair any devices.*

3.11.1.1 Paring separate music and telephone devices

It is possible to use a different music source (iPad, iPod with Bluetooth adapter, Bluetooth enabled laptop, etc) and telephone. However, the music source must be paired **first**, *before* the telephone, if the telephone also has music streaming capability. Otherwise, the Smartphone will also take over the music streaming. Note: iPhones will probably take control over other music devices. Droid phones you may select music or phone only. With Blackberry, you may have to manually select the AMX240 as audio source for each call.

3.12 Internal Recorder and playback

The AMX240 comes equipped with an internal recorder. This digital recorder stores the last incoming audio from the radio you have selected for transmit. It can store as many of 8 incoming messages, and up to 60 seconds of audio. The pilot and copilot hear the playback.

Recording is automatic. To play back the last recorded message, quickly press the REPLAY pushbutton.

You can either wait for the message to finish playing before accessing the prior message, or cancel the current playback and step backward. To cancel the playback, press and hold the REPLAY button for two seconds (2). The next time the button is pressed for one (1) second, the next earlier message will be heard. The playback will stop whenever there is more incoming selected com audio, and the message can be replayed from the beginning by pressing the selected COM Receive button again for 1 second.



Figure 3-2 Playback Controls

Appendix A – AMX240 Installation Drawings

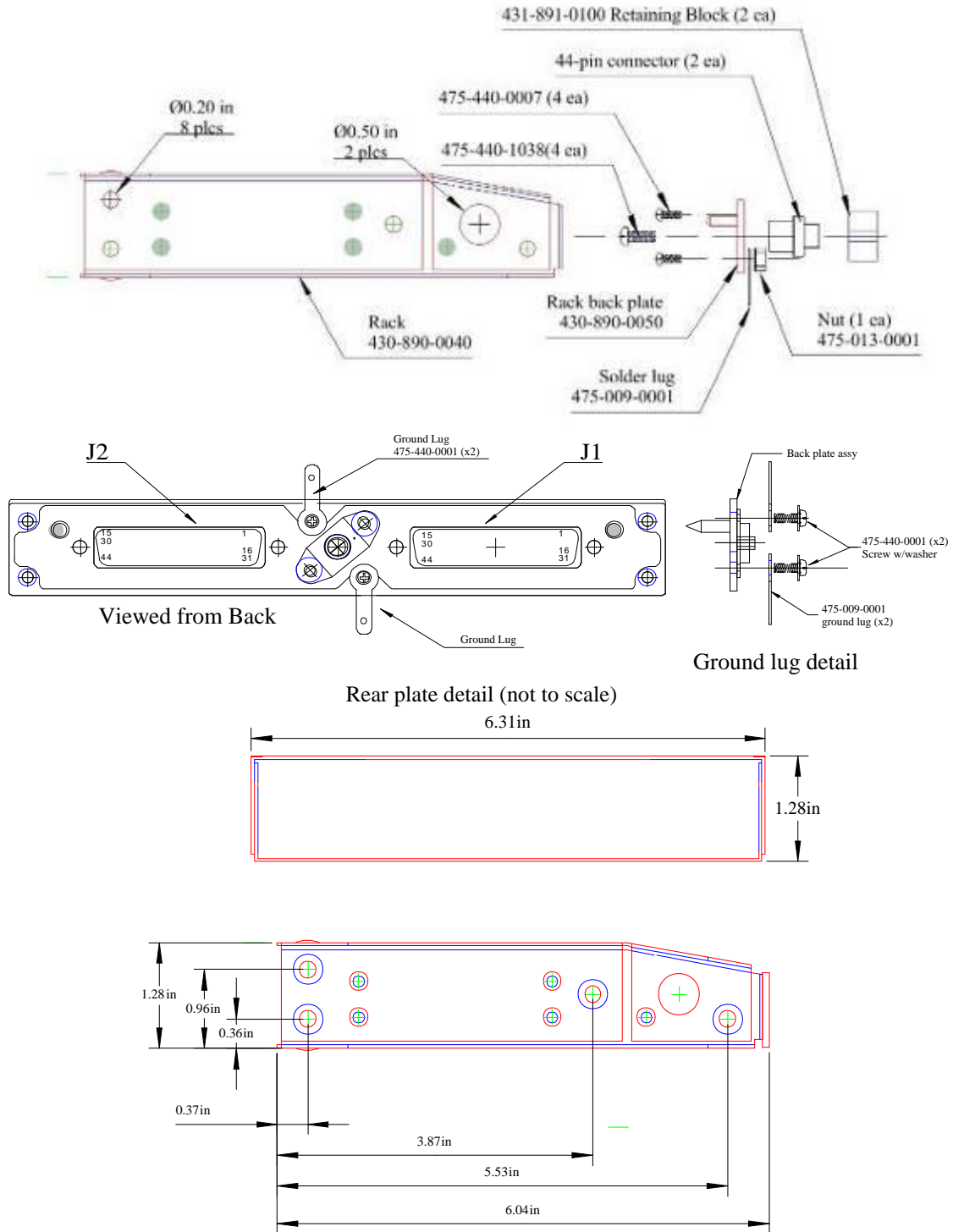

Caution: Apply steady pressure to the bezel while screwing the unit into the tray to ensure even seating of the unit and connectors.

Appendix B – J1 Connector Interconnect

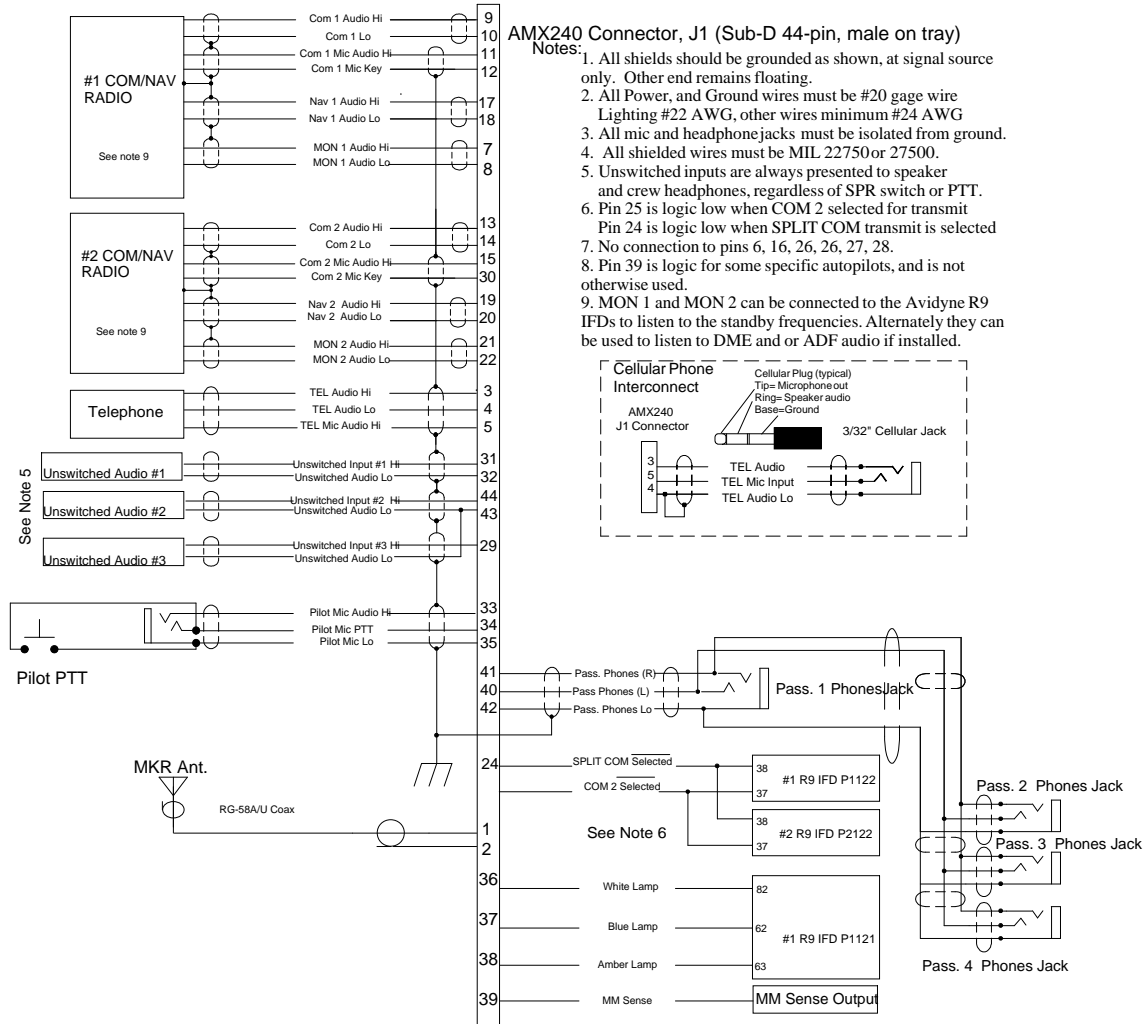

Appendix C – J2 Connector Interconnect

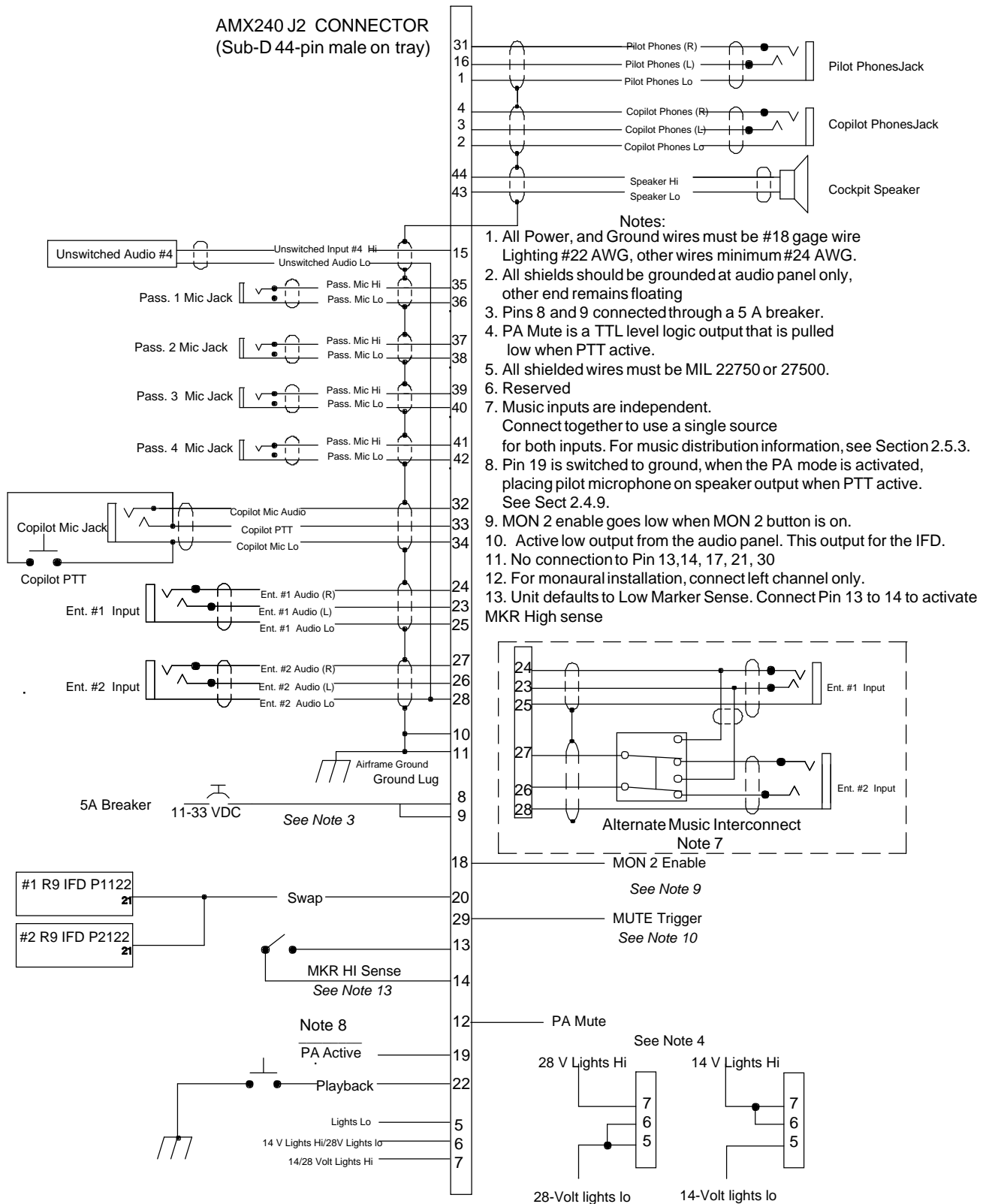

Appendix D – Instructions for FAA Form 337 and continuing airworthiness

7.1 Instructions for FAA Form 337, Audio Panels

One method of airworthiness approval is through an FAA Form 337, *Major Repair and Alteration (Airframe, Powerplant, Propeller, or Appliance)* In the case of the AMX240, you may use the following text as a guide.

Installed audio selector and 6-place intercom, Avidyne AMX240, part number 050-890-0240 in (location) at station _____. Installed per *AC43.13-2, Chapter 2, paragraph 23* (Instrument Panel Mounting). Installed per Avidyne *Installation Operators Manual* p/n 200-890-0240, revision (), dated ().

These units are FAA-Approved under TSO C50c for audio amplifiers, and/or TSO C35d for Marker Beacon Receivers, and meets appropriate environmental qualifications outlined in RTCA DO-160D as appropriate or this aircraft.

Interface to existing aircraft radios in accordance with installation manual and in compliance with practices listed in *AC43.13-2, Chapter 2*. All wires are Mil-Spec 22759 or 27500. Connection to aircraft dimmer bus is _____. Power is supplied to the unit through a 3A circuit breaker (type and part number), and total electrical load does not exceed ____% of the electrical system capacity with the AMX240 added.

Aircraft equipment list, weights and balance amended. Compass compensation checked. A copy of the operation instructions, contained in Avidyne document 600-00306-000is placed in the aircraft records. All work accomplished listed on Work Order_____.

7.2 Instructions for Continuing Airworthiness, Audio System

Sample ICA Checklist for Avidyne Audio System:

Section	Item	Information
1	Introduction	Installation of audio control panel with integrated marker beacon receiver and intercommunications system.
2	Description	Installation as described in manufacturer’s installation manual referenced on FAA Form 337, including interface with other avionics audio as required.
3	Controls	See installation and operator’s guide referenced on FAA Form 337.
4	Servicing	None Required
5	Maintenance Instructions	On Condition, no special instructions
6	Troubleshooting	In the event of a unit problem, place the unit into “off,” “fail-safe” and/or “emergency” mode. This allows pilot communications using COM 1. Follow checkout instructions in the installation manual referenced on the FAA Form 337. For a specific unit fault, contact the manufacturer for special instructions.
7	Removal and replacement information	<u>Removal:</u> Using a 3/32” Allen-head wrench, carefully unscrew the locking screw located in the center of the unit. While turning the wrench CCW, gently pull on the EDGES of the bezel until the unit is free from the mounting tray. <u>Installation:</u> Engage the locking screw at the back. Turn the locking screw CW, while applying slight pressure to the edges of the bezel. Do not over tighten!
8	Diagrams	Not applicable
9	Special Inspection Requirements	Not Applicable
10	Protective Treatments	Not Applicable
11	Structural Data	Not Applicable
12	Special Tools	None
13	Not Applicable	Not Applicable
14	Recommended Overhaul Periods	None
15	Airworthiness Limitations	Not Applicable
16	Revision	To be determined by installer

Appendix E – RTCA DO160D Environmental Qualification Form

Audio Selector Panel/Intercom/Marker Beacon Receiver

Part Number: 050-890-()

FAA TSO Number: C50c, C35d

Manufacturer: PS Engineering Inc. 9800 Martel Road Lenoir City TN 37772

Conditions	Section	Conducted Tests
Temperature and Altitude	4.0	Equipment tested to CAT A1 & D1
Low Temperature	4.5.1	-55° C Survival, -15°C Low Operating (A1) -40°C Short Term Operating (A1)
High Temperature	4.5.2	+85°C Survival, +70°C High Short Time Operating
In-flight Loss of Cooling	4.5.4	Not Applicable, no cooling required
Altitude	4.6.1	50,000' unpressurized (D1)
Decompression	4.6.2	Not Applicable
Overpressure	4.6.3	Not Applicable
Temperature variation	5.2	Equipment tested to Category C
Humidity	6.0	Equipment tested to Category A
Shock	7.0	Equipment tested to Operational test only
Operational	7.2	Equipment tested to Operational test only
Crash Safety	7.3	Equipment tested to Operational test only
Vibration	8.0	Equipment tested to Category S & U2
Explosion	9.0	Category X, not tested
Waterproofness	10.0	Category X, not tested
Fluids Susceptibility	11.0	Category X, not tested
Sand and Dust	12.0	Category X, not tested
Fungus	13.0	Category X, not tested
Salt Spray	14.0	Category X, not tested
Magnetic Effect	15.0	Equipment tested to Category Z
Power input	16.0	Equipment tested to Category B
Voltage Spike	17.0	Equipment tested to Category A
Audio Frequency Susceptibility	18.0	Equipment tested to Category B
Induced Frequency Susceptibility	19.0	Equipment tested to Category A
Radio Frequency Susceptibility	20.0	Equipment tested to Category T
Radio Frequency Emission	21.0	Equipment tested to Category B
Lightning Induced Transient Susceptibility	22.0	Equipment tested to Category XXE2
Lightning Direct Effects	23.0	Category X, not tested
Icing	24.0	Category X, not tested
ESD	25.0	Category X, not tested

AMX240 Audio Panel Installation Manual

WARRANTY: AVIDYNE WARRANTS THE PRODUCT MANUFACTURED BY IT AGAINST DEFECTS IN MATERIAL AND WORKMANSHIP FOR A PERIOD OF TWENTY-FOUR (24) MONTHS FROM DELIVERY TO THE INSTALLER. A COMPLETE COPY OF THE WARRANTY DATA IS ACCESSIBLE VIA THIS WEB ADDRESS:

[HTTP://WWW.AVIDYNE.COM/SUPPORT/WARRANTY.ASP](http://www.avidyne.com/support/warranty.asp)

SOFTWARE LICENSE: AVIDYNE CORPORATION (“AVIDYNE”) IS WILLING TO LICENSE THIS SOFTWARE, AND RELATED MATERIALS (THE “SOFTWARE”) ONLY ON THE CONDITION THE USER AGREES TO THE TERMS OF THE PUBLISHED SOFTWARE LICENSE WHICH CAN BE ACCESSED VIA THIS WEB ADDRESS:

[HTTP://WWW.AVIDYNE.COM/SUPPORT/LICENSE.ASP](http://www.avidyne.com/support/license.asp)

Copyright

© 2013 Avidyne Corporation. All rights reserved. Reproduction of this publication or any portion thereof by any means without the express written consent of Avidyne Corporation is prohibited. For further information contact Avidyne Corporation, 55 Old Bedford Road, Lincoln, MA 01773, 781-402-7400. Information in this document is subject to change without notice. Avidyne reserves the right to change or improve their products and to make changes in the content of this material without obligation to notify any person or organization of such changes or improvements.



AVIDYNE CORPORATION
55 Old Bedford Road
Lincoln, MA 01773
Telephone: 781-402-7400
www.avidyne.com