

Xcel[®] / AccuSense[®] CHARGE SERIES FULLY AUTOMATIC MULTI-CHEMISTRY BATTERY CHARGER

Features:

- Fully Automatic - starts and stops charging automatically
- 5 L.E.D. display to easily interpret charge and/or charge error conditions
- Charge algorithm controls BOTH voltage and current for precise charging
- Microprocessor-based control implements an intelligent charge
- Inhibit Lockout circuit (optional) prevents vehicle operation while charging

SPECIFICATIONS:

Part Numbers: z-24E020-04-HF 24Vdc 20A dc Output

Input: z = 1: 120Vac, 50 / 60Hz
z = 2: 230Vac, 50 / 60Hz

**IMPORTANT: READ AND SAVE THIS SAFETY
INSTRUCTION MANUAL
KEEP IT WITH OR NEAR CHARGER AT ALL TIMES**

Table of Contents

<u>Section</u>	<u>Description</u>	<u>Pg</u>	<u>Section</u>	<u>Description</u>	<u>Pg</u>
1	User Safety	2	6	L.E.D. Display	6
2	Installation	3	7	Troubleshooting	7
3	Grounding	3	8	Technical Notes	9
4	Preparing to Charge	4	9	External Wiring	10
5	5-Stage Charge	5	10	Warranty	11

 Throughout this manual, look for this symbol. It means BE ALERT – YOUR SAFETY IS INVOLVED. If you do not follow these safety instructions, personal injury or property damage may occur.

1. User Safety Operations Guide

 WARNING - RISK OF EXPLOSIVE GASES.

WORKING WITH RECHARGEABLE BATTERY(S) IS DANGEROUS. EXPLOSIVE GASES DEVELOP DURING NORMAL BATTERY OPERATION. READ THIS MANUAL EACH TIME AND MAKE CERTAIN YOU FULLY UNDERSTAND IT AND FOLLOW THE SAFETY AND OPERATING INSTRUCTIONS AT ALL TIMES.

- To reduce risk of battery explosion, follow all safety instructions below and those published by the battery manufacturer. Review cautionary markings on vehicle or equipment containing the battery.
- Use of an attachment not recommended or sold by the battery charger manufacturer may result in a risk of fire, electric shock or injury to persons.
- Do not operate this charger if it has received a sharp blow, was dropped or otherwise damaged in any manner. Refer to a qualified service agent.
- Charger contains no serviceable parts. If it fails during its warranty period, contact your dealer for a warranty replacement.
- To reduce risk of electric shock, unplug charger from AC outlet before attempting any maintenance or cleaning.
- For external cleaning use a clean damp towel.
- Have your distributor, dealer or other qualified service agent, repair or replace worn or damaged parts immediately. **Repairs should not be attempted by people who are not qualified.**
- Whenever removing AC Plug from the receptacle, pull from the Plug Body; Not from the cord.
- Do not operate the charger if it is malfunctioning. Personal injury or property damage could result.
- **Personal Precautions While Working With Batteries**
- Have someone within range of your voice to come to your aid if needed.
- Have plenty of fresh water and soap nearby in case battery acid contacts your skin, clothing or eyes. Wear eye and clothing protection and avoid touching eyes.

- If battery acid contacts skin or clothing, wash immediately with soap and water.
- If acid enters eye, immediately flush eye with running cold water for at least 10 minutes. Get medical attention immediately.
- NEVER smoke or allow a spark or flame in vicinity of battery.
- Be extra cautious not to drop a metal tool onto battery. It might spark or short circuit battery or other electrical part that may cause an explosion.
- Remove personal metal items such as rings, necklaces, watches, etc. Batteries can produce a short-circuit current high enough to weld such items causing a severe burn.
- NEVER charge a frozen battery. Thaw it out for safer and more efficient charging.

 **WARNING: CHARGERS CAN IGNITE FLAMMABLE MATERIALS AND VAPORS. DO NOT USE NEAR FUELS, GRAIN DUST, SOLVENTS, OR OTHER FLAMMABLES. TO REDUCE THE RISK OF AN ELECTRIC SHOCK, KEEP THE CHARGER DRY. DO NOT EXPOSE IT TO RAIN OR WATER.**

2. Installation

- The use of an improper extension cord could result in a risk of a fire or electric shock. If an extension cord must be used, it must be UL and/or CSA approved. Locate all cords so that they will not be stepped on, tripped over or otherwise subjected to damage or stress. Extension cord must be properly wired and in good electrical condition, and large enough for the AC rating of charger as specified in this TABLE:

RECOMMENDED MINIMUM AWG SIZE FOR EXTENSION CORDS FOR BATTERY CHARGERS				
Length of cord (feet):	25	50	100	150
AWG size of cord:	16	16	14	12

- **Accessories List:**
AC Cord- 3 conductor: 18AWG power cable, with IEC 60320 power connector and a NEMA 5-15 3 pole power plug.

3. Grounding Instructions

- This battery charger must be grounded to reduce the risk of electric shock. This charger is equipped with an AC cord set having an equipment-grounding conductor. This AC cord set must be connected to an appropriate receptacle that is properly installed and grounded in accordance with the National Electrical Code and all local codes and ordinances.

 **WARNING: IMPROPER CONNECTION OF THE EQUIPMENT-GROUNDING CONDUCTOR CAN RESULT IN A RISK OF AN ELECTRIC SHOCK.**

- The conductor with insulation having an outer surface that is green, with or without yellow stripe(s), is the equipment-grounding conductor. If repair or replacement of the charger's AC cord set is necessary, refer to a qualified service agent, and do not connect the equipment-grounding connector to a live terminal.

4. Preparing to Charge

 **WARNING:** The instructions printed on the charger are for daily reference. For your own protection, when using ANY type of charger, always ensure that the batteries in your Battery Pack ARE ALL at the same state of charge, same condition, same size, and same rating. **DO NOT MIX DIFFERING BATTERY SIZES, BATTERY TYPES OR OLD BATTERIES WITH NEW.** Never use charger for any purpose contrary to its intended purpose of charging lead acid batteries in accordance with ALL instructions printed in this manual.

4.1 Be sure area around battery is well ventilated while battery is being charged. Gas can be forcefully blown away using a non-metallic material like cardboard.

4.2 The charger is factory preset to charge in one of 32 operating MODES. Each mode is set to charge a particular Battery Pack **AND MUST BE SET CORRECTLY IN ACCORDANCE WITH THE FOLLOWING:**

'CHARGE MODE TABLE':

Switch Setting: 0 = Switch Up 1 = Switch Down

Mode	Battery Description		AH Range	Absorption Voltage	Switch Setting (5-key left to right)				
					1	2	3	4	5
01	Exide	Flooded	180-225AH	28.8V	0	0	0	0	0
02	US Battery	Flooded	180-225AH	30.8V	0	0	0	0	1
03	Trojan	Flooded	180-225AH	28.6V	0	0	0	1	0
04	US Battery	AGM	180-225AH	28.8V	0	0	0	1	1
05	Exide	Flooded	225-300AH	28.8V	0	0	1	0	0
06	US Battery	Flooded	225-300AH	30.8V	0	0	1	0	1
07	Trojan	Flooded	225-300AH	28.6V	0	0	1	1	0
08	Full River	AGM	225-300AH	29.4V	0	0	1	1	1
09	Exide	Flooded	60-100AH	28.8V	0	1	0	0	0
10	US Battery	Flooded	60-100AH	30.8V	0	1	0	0	1
11	Trojan	Flooded	60-100AH	28.6V	0	1	0	1	0
12	Full River	AGM	60-100AH	29.4V	0	1	0	1	1
13	East Penn	Gel	180-225AH	28.0V	0	1	1	0	0
14	Full River	AGM	180-225AH	29.4V	0	1	1	0	1
15	BMZ	LiFePO4	150-200AH	28.0V	0	1	1	1	0
16-32	Empty – Do Not Use								

4.3 For 4 consecutive seconds, upon connection to AC Power, the Front Panel L.E.D.s will flash a pattern to annunciate the mode setting as Described in the following table where '0' = Off, and '1' indicates LED Flashing:

'L.E.D. CHARGE MODE INDICATOR TABLE':

LED's – Left to Right					Mode Setting
1	2	3	4	5	
0	0	0	0	1	MODE-1
0	0	0	1	0	MODE-2
0	0	0	1	1	MODE-3
0	0	1	0	0	MODE-4
0	0	1	0	1	MODE-5
0	0	1	1	0	MODE-6
0	0	1	1	1	MODE-7
0	1	0	0	0	MODE-8
0	1	0	0	1	MODE-9
0	1	0	1	0	MODE-10
0	1	0	1	1	MODE-11
0	1	1	0	0	MODE-12
0	1	1	0	1	MODE-13
0	1	1	1	0	MODE-14
0	1	1	1	1	MODE-15

Mode 16 to 32 are empty – selection of a mode in this range produces an error and the charger will not operate – refer to the Error Table below.

5. FIVE(5)-STAGE CHARGE

- 5.1. The following instructions assume the charger is operating in MODE-1.
- 5.2. Upon A.C. POWER connection, and for the first 4 seconds, the MODE is annunciated where the Right Most L.E.D. only, flashes. This is the code for MODE-1 and this MODE is applicable to that Battery Type listed in the CHARGE MODE TABLE. Following the Start-Up Flash Sequence, the 'Power On' L.E.D. will illuminate to indicate that AC power is applied; the charger then commences charging as described below.
- 5.3. The charger may be left connected to battery with the A.C. Power Removed. The amount of drain from the battery is minimal.

DPI'S 5-Stage Charging Process works as follows:

5.4. STAGE ONE - PRE-QUALIFICATION TEST

- 5.4.1. Yellow (Charging), Light Emitting Diode (L.E.D.), flashes on/off SLOWLY at a rate of once per second during this stage. This stage applies tests to the battery pack. Further charging is prohibited if the charger discovers a fault such as connection of 24v charger to a 12V battery pack or reversed battery connections, etc. Refer to Section 7 - 'Troubleshooting Guide' for understanding faults.
- 5.4.2. Duration of this stage is dependent on the condition of battery - approximately 10 seconds under average circumstances, but if your battery pack was allowed to severely discharge to less than 10.5v

(for every 12v battery), then the charger may take several hours of slow charging to try to slowly bring the battery up beyond 10.5Vdc.

5.5. STAGE TWO - CONSTANT CURRENT CHARGE (Bulk Peak Charge)

5.5.1. Yellow (Charging) L.E.D. illuminates continuously indicating that the charger is charging the battery at the full rated output. While charging, the voltage is monitored for the occurrence of the next charging stage.

5.6. STAGE THREE - CONSTANT VOLT/AMP (Top-Off Charge)

5.6.1. Yellow (Charging) L.E.D. remains illuminated continuously. The charger now regulates at the Absorption Voltage Level while monitoring charge current.

5.6.2. Once Charge Current has decreased to a sufficiently low level, the charger then illuminates continuously, both the Green (Charged) and Yellow (Charging) L.E.D.

5.6.3. The Battery Pack is now at about 80-90% State of Charge and this Top-Off stage replenishes the last 10-20% of capacity.

5.7. STAGE FOUR - CHARGE COMPLETE (Standby)

5.7.1. Green (Charged) L.E.D., only, illuminates continuously. Output Voltage is regulated at a reduced voltage to maintain the battery at full charge. However, no further charging action is occurring. If flashing, AND a temperature measuring device is installed in the charger, the battery was found to be overly warm. Flashing will stop once battery temperature returns to normal.

5.8. RECYCLE CHARGE STAGE FIVE

5.8.1. Only after the completion of Stage 4, and if a substantial load should be applied, the charger will reset itself; thereby automatically initiating a new charge cycle routine and restoring battery to full capacity.

5.8.2. If while charging, the charger finds an abnormal charge condition, it will attempt to shutdown and indicate the 'Condition' by flashing any one of the L.E.D.s Refer to the 'Troubleshooting' section for a description of the Charge Error Condition.

6. L.E.D. DISPLAY

While A.C. Power Is Connected....

Under normal charge circumstances, the L.E.D.s operate as follows:

○ Power On	(Red)	Illuminates continuously when AC power present. Refer to the section 'TROUBLESHOOTING' if Flashing.
------------	-------	---

- Shutdown (Red) Normally not illuminated. Refer to 'TROUBLESHOOTING' if Flashing.
- Detection (Red) Illuminates when battery not connected or battery voltage is less than 8V. Refer to 'TROUBLESHOOTING' if Flashing.
- Charging (Yellow) Charge Status Indicator – flashes or illuminates during the 5-Stage Charge Process. Refer to Section 5.
- Charged (Green) Illuminates continuously during the 4th Stage of the Charge Process.

7. TROUBLESHOOTING GUIDE

To be able to troubleshoot safely and effectively, it is important to read this guide completely before beginning any tests.

 **WARNING: DO NOT DISASSEMBLE THE CHARGER. TAKE IT TO A QUALIFIED SERVICE AGENT WHEN SERVICE OR REPAIR IS REQUIRED. INCORRECT REASSEMBLY MAY RESULT IN A RISK OF ELECTRIC SHOCK OR FIRE. THE FOLLOWING PROCEDURES ARE INTENDED ONLY TO DETERMINE IF A MALFUNCTION MAY EXIST IN THE CHARGER.**

 **DANGER: TO REDUCE THE RISK OF ELECTRIC SHOCK, ALWAYS DISCONNECT THE CHARGER'S AC CORD SET FROM AC POWER AND ITS DC CORD SET FROM BATTERIES BEFORE ATTEMPTING ANY MAINTENANCE OR CLEANING**

If any of the L.E.D.s flash in a pattern of '3-Fast-Flash, then off, 3-Fast-Flash etc, the charge cycle has terminated prematurely. An abnormal charging condition was detected and charging stopped due to a Charge Error Condition. Refer to the following Charge Error Table for a description of the possible failure or condition.

CHARGE ERROR TABLE

Condition	Flashing L.E.D.s				
	LED-1	LED-2	LED-3	LED-4	LED-5
Battery Voltage High	Off	Off	Off	Off	Flash
Battery Polarity Reversed	Off	Off	Off	Flash	Off
Output Overload	Off	Off	Off	Flash	Flash
Battery Pack Unbalanced-1	Off	Off	Flash	Off	Off
Battery Pack Unbalanced-2	Off	Off	Flash	Off	Flash
Excessive Charging Time-1	Off	Off	Flash	Flash	Off
Excessive Charging Time-2	Off	Off	Flash	Flash	Flash
Excessive Overload	Off	Flash	Off	Off	Off
Battery Testing - 1	Off	Flash	Off	Off	Flash
Battery Testing - 2	Off	Flash	Off	Flash	Off

Inhibit Control Defective	Off	Flash	Off	Flash	Flash
Battery Over Temperature	Off	Flash	Flash	Off	Off
Internal Over Temperature-1	Off	Flash	Flash	Off	Flash
Internal Over Temperature-2	Off	Flash	Flash	Flash	Off
External Over Temperature	Off	Flash	Flash	Flash	Flash
Mode-Selected Not Valid	Flash	Off	Off	Off	Off

- Battery Voltage High. Charger's DC cord set possibly connected to a battery pack with voltage higher than the output rating of the charger.
- Battery Polarity Reversed. Check output connector and ensure proper polarity. Remake connections.
- Output Overload. While charging, and, for example, under severe motor loading, charger may shut down. This error is not very likely to occur.
- Battery Pack Unbalanced-1,2. Caused by unbalanced battery condition. Example: some batteries are at a much higher state of charge than others. This may require replacement of the batteries. Refer to the Equipment's Operators manual for instructions on servicing the battery pack.
- Excessive Charging Time-1,2. Occurs when charging took too long. Possible causes include: use of a battery load that is draining energy from the battery while the charger is trying to charge that same battery, aged or unbalanced battery cell conditions, etc.
- Inhibit Control Defective. Inhibit is supposed to be active, but it is not. Check Inhibit vehicle wiring. If correct, internal inhibit switch may have been overload – contact factory.
- Excessive Overload. In the unlikely event that a heavy load is placed across the battery pack while the charger is trying to charge the battery and the charger cannot keep up with supplying energy to both the battery and the load, and then the battery voltage will decrease. Further charging is terminated.
- Battery Testing. This error is only generated by one of two conditions found during the Pre-Qualification Test Stage.
 - Condition 1: A severely discharged battery pack did not charge up to 10.5Vdc for 12v-system, or 21Vdc for 24V-system, within 3 hrs.
 - Condition 2: A heavy load, applied, prevents charger from charging battery pack above 10.5Vdc for 12v-system, or 21Vdc for 24V-system.
- Battery Over Temperature. If an external Thermistor was installed, the charger ceased charging due to detecting a hot battery.

- Internal Over Temperature-1,2. Charger shut down due to an internal over temperature condition – check fan operation and remove blockages, if any.

8. TECHNICAL NOTES

- Do not charge more than one battery pack at a time. Battery pack characteristics differ and may cause the microprocessor to function improperly.
- If charging a series connected string of 2 or more batteries, ensure that all batteries in the series connected string, are all at the same state of charge, age type and condition.
- The charger uses RF energy only for its internal functions. Therefore its RF emissions are very low and are unlikely to cause any interference in nearby electronic equipment.
- The charger has an operating temperature range of -10C to +55C, and a shipping/storage temperature range of -40C to +80C. It needs to be stored in clean dry conditions.
- Medical Electrical Equipment needs special precautions regarding EMC and needs to be installed and put into service according to the EMC information provided in this manual.
- Portable and mobile RF communications equipment can affect Medical Electrical Equipment.
- The use of Accessories, transducers, and cables other than those specified by the manufacturer, may result in increased Emissions or decreased Immunity of the Battery Charger.
- The Battery Charger should not be used adjacent to or stacked with other equipment and that if adjacent or stacked use is necessary, the Battery Charger should be observed to verify normal operation in the configuration in which it will be used.

9. EXTERNAL WIRING

Inhibit Wiring

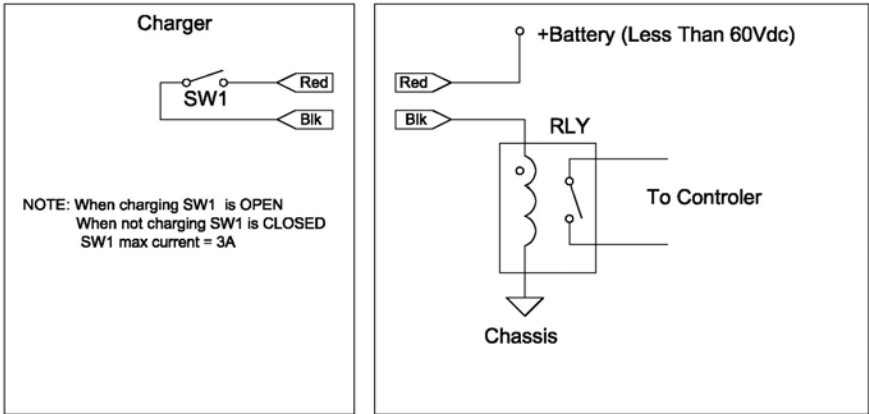

A.C. Convenience Port Accessory (Optional)

If the optional A.C. Convenience Port Accessory is include with your system, the L.E.D. display mirrors the Charger L.E.D. Display – with one exception:

If an L.E.D. pattern flashes from the center L.E.D. out, in a repeating pattern, the Port is annunciating a 'Lost Communications' error. Check wiring for continuity.

10. LIMITED WARRANTY

Diversified Power International LLC (DPI) warrants exclusively to the original purchaser that this product will be replaced or repaired, at DPI's option, if it fails during the first 10,000hrs (or 5yrs), of operation, whichever comes first, after date of purchase due to a defect in material or workmanship. In order for a claim to be processed the product must be returned to DPI (i) with all transportation charges prepaid, (ii) accompanied by an acceptable proof of purchase, and with a Return Material Authorization (RMA) number, previously obtained from DPI, printed and clearly visible on the outside of the shipping container. This warranty does not apply if the product has been modified, abused, or damaged or improperly or negligently used, connected, maintained, or operated in any manner contrary to the instructions stated in this manual or affixed to the product's enclosure. Repair or replacement as provided under this warranty is the exclusive remedy of the purchaser, and the purchaser shall have no claim against DPI except for the breach of an express warranty stated herein. DPI shall not be liable for any incidental, consequential, or special damages for breach of any expressed or implied warranty. Except to the extent required by applicable law any implied warranty of merchantability or fitness for a particular purpose is limited in duration to the first 18mos after the date of purchase. Some states do not allow the exclusion or limitation of incidental or consequential damages or allow limitations on how long an implied warranty lasts, so the above limitations or exclusion may not apply to you. This limited warranty gives you specific legal rights, and you may also have other rights which vary from state to state. APART FROM THE WARRANTIES SET FORTH ABOVE, DPI MAKES NO OTHER WARRANTY, EXPRESS OR IMPLIED, WITH RESPECT TO THE SUITABILITY OR MERCHANTABILITY OF THIS PRODUCT, THE FITNESS OR THIS PRODUCT FOR ANY SPECIFIC USE OR PURPOSE, OR ANY OTHER MATTER PERTAINING TO THIS PRODUCT.

Return information:

DIVERSIFIED POWER INTERNATIONAL LLC
414 CENTURY COURT
PINEY FLATS, TN 37686, U.S.A.
423 538-9002
RMA # _____

For further information, product updates, technical information, or general inquiries, also, please visit our web site at:

www.DPIpower.com