

SHARP

MIKRO KOMponentEN SYSTEM
MICRO-CHAÎNE
SISTEMA MICRO
MIKRO KOMponentEN SYSTEM
MICRO SISTEMI
MICRO SYSTEEM
SISTEMA DE MICRO COMPONENTE
MICRO COMPONENT SYSTEM

MODELL MODELLO
MODÈLE MODEL
MODELO MODELO
MODELL MODEL

XL-45H

BEDIENUNGSANLEITUNG
MODE D'EMPLOI
MANUAL DE MANEJO
BRUKSANVISNING

MANUALE DI ISTRUZIONI
GEBRUIKSAANWIJZING
MANUAL DE OPERAÇÃO
OPERATION MANUAL



- Mikro Komponenten System XL-45H besteht aus XL-45H (Hauptgerät) und CP-XL45H (Lautsprechersystem).
- Micro-chaîne XL-45H composée de XL-45H (appareil principal) et CP-XL45H (enceinte acoustique).
- Sistema micro XL-45H que consta de XL-45H (aparato principal) y CP-XL45H (sistema de altavoces).
- XL-45H mikro komponent system bestående av XL-45H (huvudenhet) och CP-XL45H (högtalarsystem).
- Micro sistemi XL-45H composto da XL-45H (apparecchio principale) e CP-XL45H (sistema di diffusori).
- XL-45H micro systeem bestaande uit XL-45H (hoofdtoestel) en CP-XL45H (luidsprekersysteem).
- XL-45H Sistema de Micro Componente composto de XL-45H (unidade principal) e CP-XL45H (sistema de alto-falante).
- XL-45H Micro Component System consisting of XL-45H (main unit) and CP-XL45H (speaker system).

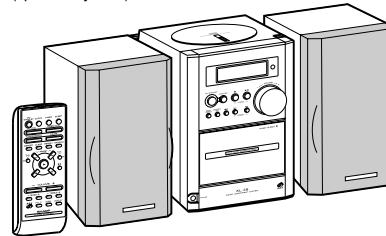

DEUTSCH	... Siehe Seiten i bis vi und D-1 bis D-30.
FRANÇAIS	... Se reporter aux pages i à vi et F-1 à F-30.
ESPAÑOL	... Consulte las páginas i a vi y S-1 a S-30.
SVENSKA	... Hänvisa till sidorna i till vi och V-1 till V-30.
ITALIANO	... Leggere le pagine i a vi e I-1 a I-30.
NEDERLANDS	... Raadpleeg de bladzijden i t/m vi en N-1 t/m N-30.
PORTUGUÊS	... Favor consultar as páginas i a vi e P-1 a P-30.
ENGLISH	... Please refer to pages i to vi and E-1 to E-30.

XL-45H

**BESONDERE ANMERKUNGEN
REMARQUES SPÉCIALES
NOTAS ESPECIALES
SÄRSKILDA ANMÄRKNINGAR
NOTE PARTICOLARI
BIJZONDERE OPMERKINGEN
NOTAS ESPECIAIS
SPECIAL NOTES**

- Dieses Gerät entspricht den Anforderungen der EG-Richtlinien 89/336/EWG und 73/23/EWG mit Änderung 93/68/EWG.
- Ce matériel répond aux exigences contenues dans les directives 89/336/CEE et 73/23/CEE modifiées par la directive 93/68/CEE.
- Este aparato satisface las exigencias de las Directivas 89/336/CEE y 73/23/CEE, modificadas por medio de la 93/68/CEE.
- Denna utrustning uppfyller kraven enligt riktlinjerna 89/336/EEC och 73/23/EEC så som kompletteras av 93/68/EEC.
- Quest'apparecchio è conforme ai requisiti delle direttive 89/336/EEC e 73/23/EEC, come emendata dalla direttiva 93/68/EEC.
- **Dichiarazione di conformità**
La società SHARP ELECTRONICS EUROPE GmbH dichiara che il prodotto SHARP MICRO SISTEMI XL-45H è costruito in conformità alle prescrizioni del D.M.n°548 del 28/8/95, pubblicato sulla G.U.n°301 del 28/12/95 ed in particolare è conforme a quanto indicato nell'art. 2, comma 1 dello stesso decreto.
- Dit apparaat voldoet aan de eisen van de richtlijnen 89/336/EEG en 73/23/EEG, gewijzigd door 93/68/EEG.
- Este equipamento obedece às exigências das directivas 89/336/CEE e 73/23/CEE, na sua versão corrigida pela directiva 93/68/CEE.
- This equipment complies with the requirements of Directives 89/336/EEC and 73/23/EEC as amended by 93/68/EEC.

- Dette udstyr overholder kravene i direktiv nr. 89/336/EEC og 73/23/EEC med tillæg nr. 93/68/EEC.
- Dette produktet oppfyller betingelsene i direktivene 89/336/EEC og 73/23/EEC i endringen 93/68/EEC.
- Tämä laite täyttää direktiivien 89/336/EEC ja 73/23/EEC vaatimukset, joita on muutettu direktiivillä 93/68/EEC.
- Η εγκατάσταση αυτή ανταποκρίνεται στις απαιτήσεις των οδηγιών της Ευρωπαϊκής Ένωσης 89/336/EOK και 73/23/EOK, αυτοί συμπληρώθηκαν από την οδηγία 93/68/EOK.

- Bei Einstellung der ON/STAND-BY-Taste auf STAND-BY ist die Netzspannung immer noch im Gerät vorhanden. Wenn die ON/STAND-BY-Taste auf STAND-BY eingestellt wird, kann das Gerät unter Verwendung der Timer-Betriebsart oder Fernbedienung in Betrieb gesetzt werden.
Warnung:
In diesem Gerät sind keine vom Benutzer wartbaren Teile vorhanden. Niemals Abdeckungen entfernen, außer wenn Sie dafür qualifiziert sind. In diesem Gerät sind gefährliche Spannungen vorhanden. Vor Ausführung von irgendwelchen Kundendienstarbeiten oder bei längerer Nichtverwendung des Gerätes stets den Netzstecker aus der Netzsteckdose ziehen.
- Lorsque la touche ON/STAND-BY est mise en STAND-BY, l'appareil est toujours sous tension. Lorsque la touche ON/STAND-BY se trouve sur la position STAND-BY, l'appareil est prêt à fonctionner par la minuterie ou la télécommande.
Avertissement:
Cet appareil contient des pièces non réparables par l'utilisateur. Personne non qualifiée n'enlèvera jamais les couvercles. L'appareil contenant des organes portés à haute tension, débrancher l'appareil avant toute réparation ou en période de non-utilisation.



- Cuando el botón ON/STAND-BY está puesto en la posición STAND-BY, todavía hay tensión dentro del aparato. Cuando el botón ON/STAND-BY está puesto en la posición STAND-BY, el aparato puede ponerse en funcionamiento utilizando el modo del temporizador o el controlador remoto.

Advertencia:

Tenga en cuenta que dentro de este aparato no hay piezas que pueda reparar. No quite nunca las tapas a menos que se esté cualificado para hacerlo. Este aparato tiene en su interior tensiones peligrosas. Desenchufe siempre la clavija de la red del tomacorriente antes de realizar cualquier servicio de mantenimiento y cuando no se use el aparato durante un largo período de tiempo.

- När ON/STAND-BY knappen är i läge STAND-BY, finns nätspänning i apparaten. Med ON/STAND-BY knappen i läge STAND-BY kan apparaten startas med timerfunktion eller fjärrkontrollen.

Varning:

Apparaten innehåller inga delar som kan åtgärdas av kunden. Höljet får endast öppnas av kvalificerad personal. Apparaten innehåller farliga spänningar. Stickkontakten ska därför dras ut från nätuttaget före reparationsarbeten och bör dras ut om apparaten inte ska användas på mycket länge.

- Quando il tasto ON/STAND-BY si trova in posizione STAND-BY, all'interno dell'apparecchio c'è ancora la corrente. Se il tasto ON/STAND-BY si trova nella posizione STAND-BY, l'unità può essere accesa con il modo timer o con il telecomando.

Avvertenza:

L'apparecchio non contiene parti riparabili dall'utente. Non togliere mai i coperchi, a meno di non essere qualificati per farlo. All'interno dell'apparecchio ci sono tensioni pericolose, per cui si deve sempre staccare la spina del cavo d'alimentazione dalla presa di corrente prima di qualsiasi intervento di manutenzione e quando non si usa l'apparecchio per un lungo periodo di tempo.

- Wanneer de ON/STAND-BY toets in de STAND-BY stand staat, loopt er nog steeds stroom (netspanning) in het toestel. Wanneer de ON/STAND-BY toets in de STAND-BY stand staat, kan het toestel ingeschakeld worden via de timerfunctie of de afstandsbediening.

Waarschuwing:

Dit toestel bevat geen door de gebruiker te repareren onderdelen. Verwijder de behuizing nooit tenzij u deskundig bent op dit gebied. In het toestel loopt een gevaarlijke spanning; haal de stekker altijd uit het stopcontact alvorens onderhoud uit te voeren of wanneer het toestel voor langere tijd niet gebruikt wordt.

- Quando o botão ON/STAND-BY estiver ajustado na posição STAND-BY, a voltagem de alimentação ainda se encontra presente dentro do aparelho. Quando o botão ON/STAND-BY estiver ajustado na posição STAND-BY, o aparelho pode ser colocado em operação através do modo de programação horária ou pelo controle remoto.

Advertência:

Neste aparelho não há partes que podem ser consertadas pelo usuário. Nunca retire a tampa, a menos que você tenha qualificação para tal. Este aparelho contém voltagens perigosas. Remova sempre o cabo de alimentação da tomada antes de efetuar qualquer conserto ou quando deixar o aparelho muito tempo fora de uso.

- When the ON/STAND-BY button is set at STAND-BY position, mains voltage is still present inside the unit. When the ON/STAND-BY button is set at STAND-BY position, the unit may be brought into operation by the timer mode or remote control.

Warning:

This unit contains no user serviceable parts. Never remove covers unless qualified to do so. This unit contains dangerous voltages, always remove mains plug from the socket before any service operation and when not in use for a long period.

XL-45H





XL-45H

- Når ON/STAND-BY-knappen er sat i STAND-BY positionen, er der stadig netspænding til stede i apparatet. Når ON/STAND-BY-knappen er sat i STAND-BY position, kan apparatet startes v.h.j.a. timer-funktionen eller fjernbetjeningen.

Advarsel:

Apparatet indeholder ingen dele, der kan repareres af brugeren selv. Fjern aldrig kabinettet med mindre De er kvalificeret hertil. Apparatet indeholder farlig strømspænding. Træk altid stikket ud af stikkontakten før der foretages reparationer, eller hvis apparatet ikke er i brug i længere tid.

PŘED SEJMUTÍM KRYTU NUTNO VYJMOUT VIDLICI ZE SÍŤOVÉ ZÁSUVKY.

PRED ZLOŽENÍM KRYTU JE NUTNÉ ODPOJÍŤ PŘÍSTROJ ZO SIETE.

DENNA APPARAT ÄR ANSLUTEN TILL 230 V VÄXELSTRÖM NÄR STICKPROPPEN ÄR INSKJUTEN I VÄGGUTTAGET. FÖR ATT FULLSTÄNDIGT KOPPLA IFRÅN APPARATEN, V.G. DRAG UT STICKPROPPEN.

- Audio-visuelles Material kann Urheberrechte umfassen, die ohne Genehmigung des Eigentümers dieser Urheberrechte nicht aufgenommen werden dürfen. Siehe die entsprechenden nationalen Gesetze.

- Le matériel audio-visuel peut comporter des oeuvres faisant l'objet de droits d'auteur qui ne peuvent être enregistrées sans l'autorisation du possesseur du droit d'auteur, veuillez vous référer aux réglementations nationales en vigueur.

- El material audiovisual puede consistir en trabajos que tengan derechos de autor y que no deben grabarse sin la autorización del poseedor de dichos derechos de autor. Sírvase consultar las leyes aplicables en su país.

- Audiovisuellt material kan innehålla upphovsrättsarbete som inte skall mångfaldigas utan tillstånd av copyrightinnehavaren. Se den tillämpliga lagen i ditt land.

- Il materiale audio-visivo che fosse soggetto a copyright non può essere registrato senza l'autorizzazione del possessore del copyright. Si prega di attenersi alle leggi in vigore sul territorio nazionale.

- Audio-visueel materiaal kan worden beschermd door auteursrechten, in welk geval het niet mag worden opgenomen zonder de toestemming van de auteursrechthouder. Zie voor nadere informatie de betreffende wetten in het land van gebruik.

- O material audiovisual pode consistir de trabalhos de direitos autorias que não devem ser gravados sem autorização do proprietário dos direitos. Favor consultar as leis vigentes em seu país.

- Audio-visual material may consist of copyrighted works which must not be recorded without the authority of the owner of the copyright. Please refer to relevant law in your country.





<p>● Vorsicht: Das Gerät weder Tropf- noch Spritzwasser aussetzen. Ansonsten besteht die Gefahr eines Brandes oder elektrischen Schlages. Es sollten keine mit Flüssigkeiten gefüllten Gegenstände wie Vasen auf dem Gerät abgestellt werden.</p>
<p>● Attention: Pour éviter un incendie ou une secousse électrique, mettre l'appareil à l'abri de l'eau (éclaboussure, goutte). Ne pas poser sur l'appareil un récipient contenant du liquide.</p>
<p>● Advertencia: Para evitar incendios y descargas eléctricas, no exponga el aparato a goteo o salpicadura de líquidos. No deberán ponerse encima del aparato objetos que estén llenos de líquido, como por ejemplo un florero.</p>
<p>● Varning: Utsätt inte enheten för dropp eller stänk för att förhindra brand eller elektriska stötar. Inga vätskefyllda föremål såsom vaser bör placeras på enheten.</p>
<p>● Attenzione: Per prevenire incendi o scosse elettriche, non fare gocciolare nessun liquido sull'apparecchio e non bagnarlo. Non collocarvi sopra nessun oggetto riempito d'acqua, come per esempio vasi.</p>
<p>● Waarschuwing: Stel het toestel niet bloot aan druipend of spatkend water om brand en elektrische schokken te voorkomen. Met vloeistoffen gevulde voorwerpen, zoals vazen, mogen niet op het toestel geplaatst worden.</p>
<p>● Cuidado: Para evitar incendio ou choque elétrico, não exponha este aparelho a gotejamento ou salpicamento de água. Não coloque objetos com água como, por exemplo, um vaso de flores, em cima do aparelho.</p>
<p>● Warning: To prevent fire or shock hazard, do not expose this appliance to dripping or splashing. No objects filled with liquids, such as vases, should be placed on the apparatus.</p>

<p>● Advarsel: Til at forbygge ild og stød risiko, lad vaere med at undsaette denne indretning for drypning eller overstaenkning. Der må ikke anbringes nogen genstande fyldt med vand, som for eksempel vaser, på dette apparat.</p>
<p>● Advarsel: For å unngå brann eller kortslutning, utsett ikke produktet for vann eller fuktighet. Gjenstander som inneholder vaeske, feks. en blomstervase, må ikke plasseres oppå apparatet.</p>
<p>● Varoitus: Älä vie laitetta sateeseen tai kosteisiin tiloihin. Jos laite on kostunut, anna sen kuivua ennen kuin käytät sitä verkkovirralla. Nestettä sisältäviä astioita kuten esim. kukkamaljakoita ei saa asettaa laitteen päälle.</p>
<p>PŘÍSTROJ NEVYSTAVUJTE KAPAJÍCÍ NEBO STŘÍKAJÍCÍ VODĚ. PRÍSTROJ NEVYSTAVUJTE KVAPKAJÚCEJ ALEBO STRIEKAJÚCEJ VODE. Urządzenie należy chronić przed zalaniem i wilgocią.</p>
<p>● Dieses Produkt ist ein Laserprodukt der Klasse 1. ● Ce produit est classifié comme étant un LASER DE CLASSE 1. ● Este producto está clasificado como un PRODUCTO LASER DE CLASE 1. ● Denna produkt klassificeras som KLASS 1 LASERPRODUKT. ● Questo prodotto è classificato come CLASS 1 LASER PRODUCT. ● Dit product is geclassificeerd als een KLASSE 1 LASER PRODUCT. ● Este produto é classificado como PRODUTO LASER DE CLASSE 1. ● This product is classified as a CLASS 1 LASER PRODUCT.</p>
<p>● Dette produktet er klassifisert som et KLASSE 1 LASERPRODUKT. ● Dette produkt er klassificeret som et KLASSE 1 LASERPRODUKT. ● Tämä laite on luokiteltu LUOKAN 1 LASERLAITTEEKSI. ● Denna produkt klassificeras som KLASS 1 LASERAPPARAT. ● Tento výrobek je klasifikován jako LASEROVÝ VÝROBEK TŘÍDY 1. ● Tento výrobek je klasifikovaný ako LASEROVÝ VÝROBOK TRIEDY 1.</p>

XL-45H





XL-45H

● VORSICHT

Verwendung von Regelungen oder Einstellungen bzw. Durchführung von anderen Verfahren als die hierin angegebenen kann zum Aussetzen gefährlicher Strahlung führen.

Da der in diesem Compact Disc Player verwendete Laserstrahl für die Augen schädlich ist, ist das Gehäuse unter keinen Umständen zu zerlegen.

Wenden Sie sich für Wartungsarbeiten nur an berechtigten Fachhändler.

● ATTENTION

Respecter les indications données relatives à la manipulation, au réglage et au fonctionnement. En cas de non-respect, on s'exposera à une radiation dangereuse.

Éviter absolument de démonter l'appareil, qui utilise un rayon laser nuisible aux yeux. Pour toute réparation, s'adresser à une personne qualifiée.

● PRECAUCIÓN

El uso de los controles, ajustes o ejecución de procedimientos distintos de los especificados podría causar la exposición a radiación peligrosa.

No intente desmontar la caja ya que el haz de láser usado en este reproductor de discos compactos es perjudicial para los ojos. Para el servicio de reparación, consulte a una persona cualificada.

● OBSERVERA

Användning av reglage eller justeringar eller handhavande på annat sätt än som anges kan leda till farlig bestrålning.

Försök inte ta isär höljet eftersom CD-spelarens laserstråle är skadlig för ögonen. Överlåt service endast till kvalificerad personal.

● ATTENZIONE

L'uso dei comandi e l'effettuazione di regolazioni e procedimenti diversi da quelli specificati nel manuale possono provocare una pericolosa esposizione alle radiazioni.

Poiché il raggio laser usato in questo giradischi può danneggiare gli occhi, non smontare l'apparecchio. Per le riparazioni rivolgersi a personale specializzato.

● LET OP

Gebruik van regelaars, het maken van instellingen, gebruik of handelingen anders dan in deze gebruiksaanwijzing vermeld, kan gevaarlijke straling blootleggen.

De laserstraal in deze CD-speler kan de ogen beschadigen. Probeer derhalve de ombouw niet te verwijderen. Laat reparaties alleen over aan erkend onderhoudspersoneel.

● CUIDADO

O uso de controles, ajustes ou a execução de procedimentos além daqueles especificados aqui pode resultar em perigosa exposição à radiação.

Como os raios laser usados neste player de CD são perigosos para os olhos, não tente desmontar o aparelho. Solicite o conserto somente para pessoas especializadas.

● CAUTION

Use of controls, adjustments or performance of procedures other than those specified herein may result in hazardous radiation exposure.

As the laser beam used in this compact disc player is harmful to the eyes, do not attempt to disassemble the cabinet. Refer servicing to qualified personnel only.

VÝSTRAHA: VÝROBEK JE VYBAVEN LASEREM. PŘI NESPRÁVNÉ MANIPULACI S PŘÍSTROJEM V ROZPORU S TÍMTO NÁVODEM MŮŽE DOJÍT K NEBEZPEČNÉMU OZÁŘENÍ. NEOTVÍREJTE A NESNÍMEJTE PRŮTO ŽÁDNÉ KRYTY A PŘÍSTROJ NEOPRAVUJTE, OPRAVU A SERVIS SVĚŘTE ODBORNÉMU SERVISU.

VÝSTRAHA: VÝROBK JE VYBAVENÝ LASEROM. PRI NESPRÁVNOM MANIPULOVANÍ S PŘÍSTROJOM V ROZPORE S TÝMTO NÁVODOM MÔŽE DÔJŤ K NEBEZPEČNÉMU OŽIARENÍ. NEODKRYVAJTE PRETO ŽIADNE KRYTY A PŘÍSTROJ NEOPRAVUJTE, OPRAVU A SERVIS PRENECHAJTE ODBORNÉMU SERVISU.

V

*XL45HH_XP5.pm

5

02.9.18, 10:06 AM



Eigenschaften der Laserdiode

Material: GaAlAs
Wellenlänge: 780 nm
Emissionsdauer: kontinuierlich
Laser-Ausgang: max. 0,6 mW

Caractéristiques de la diode laser

Matière: GaAlAs
Longueur d'onde: 780 nm
Durée d'émission: ininterrompue
Puissance de sortie laser maximale: 0,6 mW

Características del diodo láser

Material: GaAlAs
Longitud de onda: 780 nm
Duración de emisión: continua
Salida de láser: máx. 0,6 mW

Laserdiodens egenskaper

Material: GaAlAs
Våglängd: 780 nm
Utstrålningsvaraktighet: kontinuerlig
Lasereffekt: max. 0,6 mW

Proprietà del diodo laser

Materiale: GaAlAs
Lunghezza d'onda: 780 nm
Durata di emissione: continua
Uscita massima del laser: 0,6 mW

Laser diode specificaties

Materiaal: GaAlAs
Golflengte: 780 nm
Stralingsduur: doorlopend
Laseruitgang: max. 0,6 mW

Propriedades do diodo laser

Material: GaAlAs
Comprimento de onda: 780 nm
Duração da emissão: contínua
Saída de laser: máx. 0,6 mW

Laser Diode Properties

Material: GaAlAs
Wavelength: 780 nm
Emission Duration: continuous
Laser Output: max. 0.6 mW

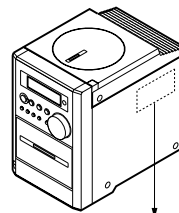

XL-45H

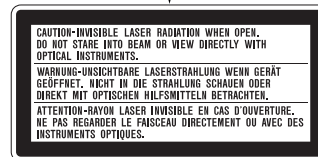

ADVERSEL-SYNLIG OG USYNLIG LASERSTRÅLING VED ÅBNING.
SE IKKE IND I STRÅLEN-HELLER IKKE MED OPTISKE INSTRUMENTER.
VARO! AVATTAESSA OLET ALTTIINA NÄKYVÄLLE JA NÄKYMÄTTÖMÄLLE
LASERSÄTEILYLLE ÄLÄ TUJOTA SÄTEESEEN ÄLÄKÄ KATSO SITÄ
OPTISEN LAITTEEN LÄPI.

VARNING-SYNLIG OCH OSYNLIG LASERSTRÅLNING NÄR DENNA
DEL ÄR ÖPPNAD. STIRRA EJ IN I STRÅLEN OCH BETRAKTA EJ
STRÅLEN GENOM OPTISKT INSTRUMENT.

**VAROITUS! LAITTEEN KÄYTTÄMINEN MUULLA KUIN TÄSSÄ
KÄYTTÖOHJEESSA MAINITULLA TAVALLA SAATTAA
ALTISTAA KÄYTTÄJÄN TURVALLISUUSLUOKAN 1
YLITTÄVÄLLE NÄKYMÄTTÖMÄLLE LASERSÄTEILYLLE.**

**VARNING - OM APPARATEN ANVÄNDS PÅ ANNAT SÄTT ÄN
I DENNA BRUKSANVISNING SPECIFICERAS. KAN
ANVÄNDAREN UTSÄTTAS FÖR OSYNLIG LASER-
STRÅLNING, SOM ÖVERSKRIDER GRÄNSEN FÖR
LASERKLASS 1.**



ENGLISH

ENGLISH



General Information

Introduction

Thank you for purchasing this SHARP product. To obtain the best performance from this product, please read this manual carefully. It will guide you in operating your SHARP product.

Accessories

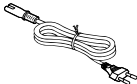
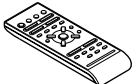
Please confirm that the following accessories are included.

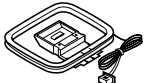
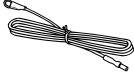
 AC power lead × 1	 Remote control × 1
 "AA" size battery (UM/SUM-3, R6, HP-7 or similar) × 2	 AM loop aerial × 1
 FM aerial × 1	

Note:
Only the above accessories are included.

Contents

	Page
■ General Information	
Precautions	2
Controls and indicators	3, 4
■ Preparation for Use	
System connections	5, 6
Remote control	7
■ Basic Operation	
Sound control	8
Setting the clock	9
■ CD Playback	
Listening to a CD	10 - 12
Programmed play	13
■ Radio	
Listening to the radio	14
Listening to the memorised station	15
■ RDS Radio	
Using the Radio Data System (RDS)	16 - 20
■ Tape Playback	
Listening to a cassette tape	21, 22
■ Tape Recording	
Recording to a cassette tape	23, 24
■ Advanced Features	
Timer and sleep operation	25 - 27
Enhancing your system	27
■ References	
Troubleshooting chart	28, 29
Maintenance	29
Specifications	30

Precautions

■ General

- Please ensure that the equipment is positioned in a well-ventilated area and that there is at least 10 cm (4") of free space along the sides and back. There must also be a minimum of 20 cm (8") of free space on the top of the unit.

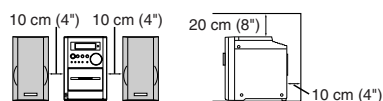

- Use the unit on a firm, level surface free from vibration.
- Keep the unit away from direct sunlight, strong magnetic fields, excessive dust, humidity and electronic/electrical equipment (home computers, facsimiles, etc.) which generate electrical noise.
- Do not place anything on top of the unit.
- Do not expose the unit to moisture, to temperatures higher than 60°C (140°F) or to extremely low temperatures.
- If the system does not work properly, unplug and plug it in again. Then turn on the system.
- In case of an electrical storm, unplug the unit for safety.
- Hold the AC power plug by the head when removing it from the wall socket, as pulling the lead can damage internal wires.
- **Do not remove the outer cover, as this may result in electric shock. Refer internal service to your local SHARP service facility.**

- The ventilation should not be impeded by covering the ventilation openings with items, such as newspapers, tablecloths, curtains, etc.
- No naked flame sources, such as lighted candles, should be placed on the apparatus.
- Attention should be drawn to the environmental aspects of battery disposal.
- The apparatus is designed for use in moderate climate.
- This unit should only be used within the range of 5°C - 35°C (41°F - 95°F).

Warnings:

- The voltage used must be the same as that specified on this unit. Using this product with a higher voltage other than that which is specified is dangerous and may result in a fire or other type of accident causing damage. SHARP will not be held responsible for any damage resulting from use of this unit with a voltage other than that which is specified.
- **CD players use a laser pickup which can damage the eyes if viewed directly. Do not look at the pickup, and do not touch the pickup directly.**

■ Volume control

The sound level at a given volume setting depends on speaker efficiency, location, and various other factors. It is advisable to avoid exposure to high volume levels, to avoid this do not turn the volume on to full at switch on and listen to music at moderate levels.

Controls and indicators

ENGLISH

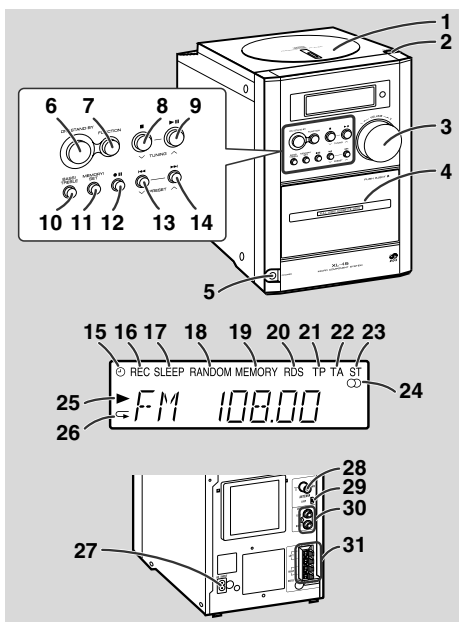

	Reference page
1. CD Compartment	10
2. CD Eject Button	10
3. Volume Control	8
4. Cassette Compartment	21
5. Headphone Socket	11
6. On/Stand-by Button	6
7. Function Selector Button	10, 14, 21, 27
8. CD or Tape Stop, Tuning Down Button	11, 14, 22
9. CD Play or Pause, Tape Play, Tuning Up Button	10, 11, 14, 21
10. Bass/Treble Selector Button	8
11. Memory/Set Button	13, 15
12. Tape Record Pause Button	23, 24
13. CD Track Down or Fast Reverse, Tape Rewind, Tuner Preset Down Button	11, 12, 15, 22
14. CD Track Up or Fast Forward, Tape Fast Forward, Tuner Preset Up Button	11, 12, 15, 22
15. Timer Play Indicator	
16. Tape Record Indicator	
17. Sleep Indicator	
18. CD Random Play Indicator	
19. Memory Indicator	
20. RDS Indicator	
21. Traffic Programme Indicator	
22. Traffic Announcement Indicator	
23. FM Stereo Mode Indicator	
24. FM Stereo Receiving Indicator	
25. CD Play Indicator	
26. CD Repeat Play Indicator	
27. AC Power Input Socket	5, 6
28. FM 75 Ohms Aerial Socket	5, 6
29. AM Loop Aerial Socket	5, 6
30. Video/Auxiliary (Audio Signal) Input Sockets	27
31. Speaker Terminals	5, 6

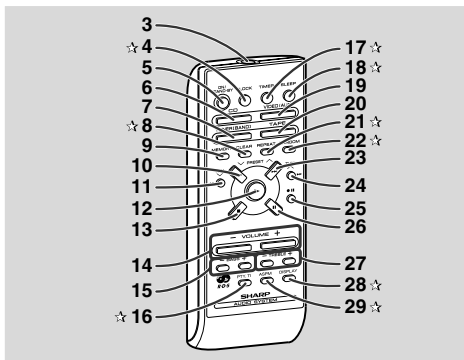
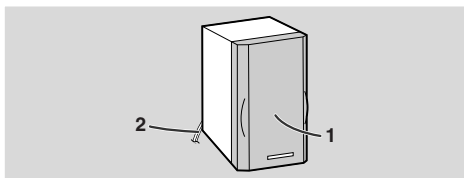

Buttons with "☆" mark in the illustration can be operated on the remote control only.

- 1. Full-Range Speaker
- 2. Speaker Wire

	Reference page
3. Remote Control Transmitter	7
4. Clock Button	9
5. On/Stand-by Button	7
6. CD Button	10
7. Tuner and Band Selector Button	14
8. Clear Button	13, 15
9. Memory Button	9, 13, 15
10. CD Track Down, Tuner Preset Down Button	9, 11, 12, 15
11. CD Fast Reverse, Tuning Down, Tape Rewind Button	12, 14, 22
12. CD or Tape Play Button	10, 21
13. CD or Tape Stop Button	11, 22
14. Volume Up and Down Buttons	8, 25
15. Bass Up and Down Buttons	8
16. RDS Programme Type/Traffic Information Search Button	20
17. Timer Button	25
18. Sleep Button	26
19. Video/Auxiliary Button	27
20. Tape Button	21
21. Repeat Button	12
22. Random Button	12
23. CD Track Up, Tuner Preset Up Button	9, 11, 12, 15
24. CD Fast Forward, Tuning Up, Tape Fast Forward Button	12, 14, 22
25. Tape Record Pause Button	23, 24
26. CD Pause Button	11
27. Treble Up and Down Buttons	8
28. RDS Display Mode Selector Button	16
29. RDS ASPM (Auto Station Programme Memory) Button	19

General Information

System connections

ENGLISH

Preparation for Use

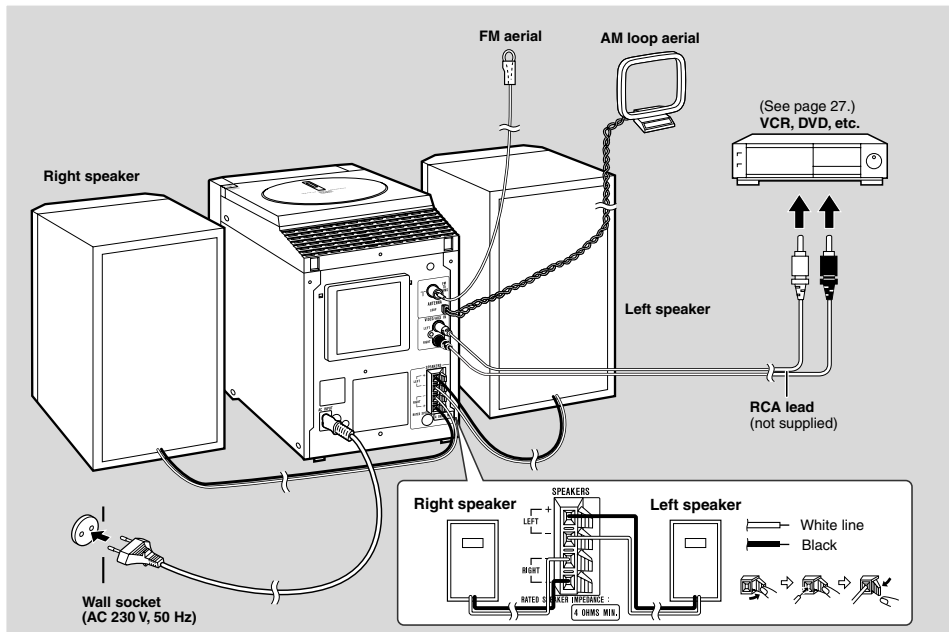

■ Aerial connection

Supplied FM aerial:

Connect the FM aerial wire to the FM 75 OHMS socket and position the FM aerial wire in the direction where the strongest signal can be received.

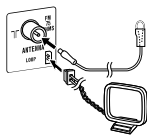

Supplied AM loop aerial:

Connect the AM loop aerial to the LOOP socket. Position the AM loop aerial for optimum reception. Place the AM loop aerial on a shelf, etc., or attach it to a stand or a wall with screws (not supplied).

Note:

Placing the aerial on the unit or near the AC power lead may cause noise pickup. Place the aerial away from the unit for better reception.

Installing the AM loop aerial:

< Assembling >

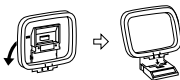

< Attaching to the wall >



External FM aerial:

Use an external FM aerial if you require better reception. Consult your dealer.

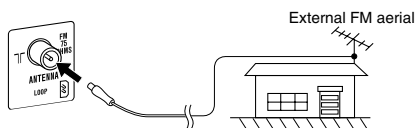

■ Speaker connection

Connect the wire with the white line to the minus (-) terminal and the black wire to the plus (+) terminal.

Caution:

- Use speakers with an impedance of 4 ohms or more, as lower impedance speakers can damage the unit.
- Do not mistake the right and the left channels. The right speaker is the one on the right side when you face the unit.
- **Do not let the bare speaker wires touch each other.**

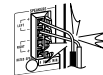

Incorrect

Placing the speaker system:

There is no distinction between the right and the left speakers.

Note:

The speaker grilles are not removable.

■ Connecting the AC power lead

After checking all the connections, connect the AC power lead to the AC power input socket, then plug the AC power lead of this unit into the wall socket.

Notes:

- Unplug the unit if it is not to be used for a prolonged period of time.
- Never use a power lead other than the one supplied. Otherwise, a malfunction or an accident may occur.

■ To turn the power on

Press the ON/STAND-BY button to turn the power on.

To set the unit to the stand-by mode:

Press the ON/STAND-BY button again.

Remote control

ENGLISH

Preparation for Use

■ Battery installation

- 1 Remove the battery cover.
- 2 Insert the supplied batteries according to the direction indicated in the battery compartment.
When inserting or removing the batteries, push them towards the battery terminals.
- 3 Replace the cover.

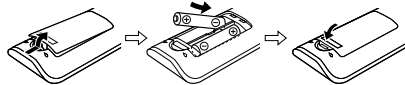

Precautions for battery use:

- Replace all old batteries with new ones at the same time.
- Do not mix old and new batteries.
- Remove the batteries if the unit is not to be used for long periods of time. This will prevent potential damage due to battery leakage.

Caution:

- Do not use rechargeable batteries (nickel-cadmium battery, etc.).
- Installing the batteries incorrectly may cause the unit to malfunction.

Notes concerning use:

- Replace the batteries if the operating distance is reduced or if the operation becomes erratic. Purchase 2 "AA" size batteries (UM/SUM-3, R6, HP-7 or similar).
- Periodically clean the transmitter on the remote control and the sensor on the unit with a soft cloth.
- Exposing the sensor on the unit to strong light may interfere with operation. Change the lighting or the direction of the unit.
- Keep the remote control away from moisture, heat, shock, and vibrations.

■ Test of the remote control

Face the remote control directly to the remote sensor on the unit.

The remote control can be used within the range shown below: Press the ON/STAND-BY button. Does the power turn on? Now, you can enjoy the music.

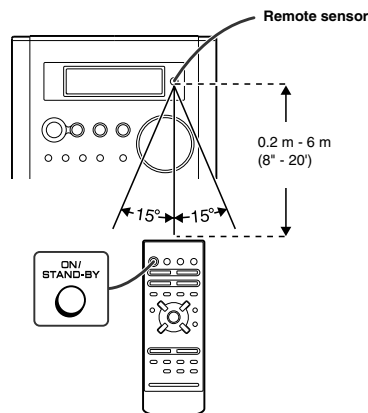

Sound control

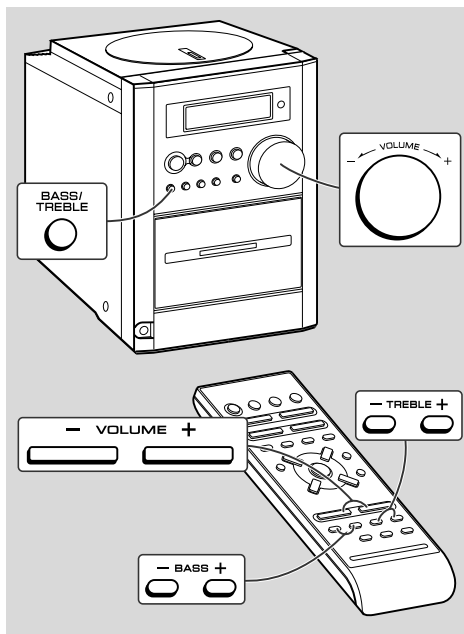

■ Adjusting the volume

Main unit operation:

When the VOLUME control is turned clockwise, the volume will increase. When it is turned anti-clockwise, the volume will decrease.

Remote control operation:

Press the VOLUME + button to increase the volume and the VOLUME - button to decrease the volume.

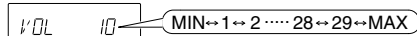

■ Adjusting the bass

Main unit operation:

- 1 Press the BASS/TREBLE button to select "BASS".
- 2 Within 5 seconds, turn the VOLUME control to adjust the bass.

Remote control operation:

Press the BASS (- or +) button to adjust the bass.

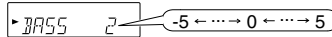

■ Adjusting the treble

Main unit operation:

- 1 Press the BASS/TREBLE button to select "TRE".
- 2 Within 5 seconds, turn the VOLUME control to adjust the treble.

Remote control operation:

Press the TREBLE (- or +) button to adjust the treble.

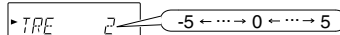

XL-45H

ENGLISH

Basic Operation

E-8

8

Setting the clock

ENGLISH

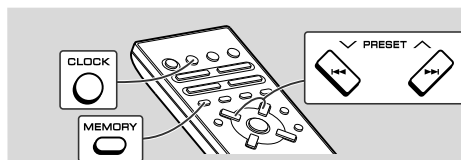

This may be operated only with the remote control.
In this example, the clock is set for the 24-hour (0:00) display.

- 1** Press the **CLOCK** button and within 3 seconds, press the **MEMORY** button.



- 2** Within 1 minute, press the **PRESET** (∨ or ∧) button to select 24-hour or 12-hour display and then press the **MEMORY** button.

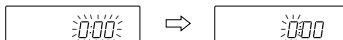

"0:00" → The 24-hour display will appear.
(0:00 - 23:59)

"AM 12:00" → The 12-hour display will appear.
(AM 12:00 - PM 11:59)

Note that this can only be set when the unit is first installed or it has been reset. (Refer to "Clearing all the memory (reset)" on page 29.)

- 3** Within 1 minute, press the **PRESET** (∨ or ∧) button to adjust the hour and then press the **MEMORY** button.

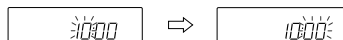

When the 12-hour display is selected, "AM" will change automatically to "PM".

- 4** Within 1 minute, press the **PRESET** (∨ or ∧) button to adjust the minutes and then press the **MEMORY** button.

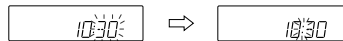

The clock starts from "0" second. (Seconds are not displayed.)

To confirm the time display when the power is on:

Press the **CLOCK** button.
The time display will appear for about 5 seconds.

Note:

The "0:00" or time will flash when the AC power supply is restored after a power failure or unplugging the unit.
Readjust the clock as follows.

To readjust the clock:

Perform "Setting the clock" from the beginning. If the time is flashing, step 2 (for selecting the 24-hour or 12-hour display) will be skipped.

To change the 24-hour or 12-hour display:

- 1 Clear all the programmed contents. [Refer to "Clearing all the memory (reset)" on page 29 for details.]
- 2 Perform "Setting the clock" from the beginning.

Listening to a CD

This system can play audio CD-R and CD-RW discs just like CD discs, but cannot perform recording. Playback of audio CD-R or CD-RW may not be performed depending on the disc state or the device you used for recording.

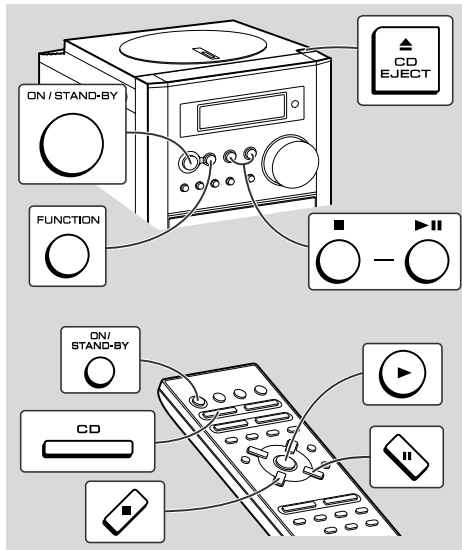

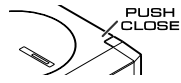
- 1 Press the ON/STAND-BY button to turn the power on.**
- 2 Press the FUNCTION button until "CD STOP" appears on the display.**
When operating with the remote control, press the CD button.
- 3 Press the ▲ CD EJECT button to open the CD compartment.**
- 4 Place a CD on the spindle, label side up.**

- 5 Close the CD compartment by firmly pushing the corner marked "PUSH CLOSE".**

16	47:38
Total number of tracks	Total playing time
- 6 Press the ▶▶ (▶) button to start playback from track 1.**
When the last track on the disc has finished playing, the CD player will stop automatically.

Listening to a CD (continued)

ENGLISH

To interrupt playback:

Main unit operation:

Press the **⏏** button.

To resume playback from the same point, press the **⏏** button again.

Remote control operation:

Press the **⏏** button.

To resume playback from the same point, press the **▶** button.

To stop playback:

Press the **■** button.

To remove the CD:

Whilst in the stop mode, press the **▲** CD EJECT button.

After use:

Press the ON/STAND-BY button to enter the power stand-by mode.

Caution:

- If a disc is damaged, dirty, or loaded upside down, "NO DISC" or "READ ERR" will appear on the display.
- Keep foreign objects out of the CD compartment.
- Subjecting the unit to shock or vibration may cause mistracking.
- When the unit is not being used, be sure to close the CD compartment. If it is left open, the lens may be covered with dust and the unit may not operate properly.
- If TV or radio interference occurs during CD operation, move the unit away from the TV or radio.

Headphones



- Before plugging in or unplugging the headphones, reduce the volume.
- Be sure your headphones have a 3.5 mm (1/8") diameter plug and are between 16 ohms and 50 ohms impedance. The recommended impedance is 32 ohms.
- Plugging in the headphones disconnects the speakers automatically. Adjust the volume using the VOLUME control.

Care of compact discs

Compact discs are fairly resistant to damage, however mistracking can occur due to an accumulation of dirt on the disc surface. Follow the guidelines below for maximum enjoyment from your CD collection and player.

- Do not write on either side of the disc, particularly the non-label side from which signals are read. Do not mark this surface.
- Keep your discs away from direct sunlight, heat, and excessive moisture.
- Always hold the CDs by the edges. Fingerprints, dirt, or water on the CDs can cause noise or mistracking. If a CD is dirty or does not play properly, clean it with a soft, dry cloth, wiping straight out from the centre, along the radius.

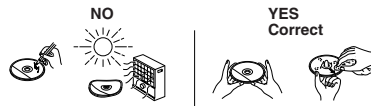

To locate the beginning of a track

To move to the beginning of the next track:

Press the **⏏** button for less than 0.5 seconds during playback.



- You can skip to any track by pressing the **⏏** button repeatedly until the desired track number appears.

To restart the track being played:

Press the **⏮** button for less than 0.5 seconds during playback.



- You can skip to any track by pressing the **⏮** button repeatedly until the desired track number appears.

■ To locate the desired portion

For audible fast forward:

Press and hold down the ►► button on the main unit or the ►► button on the remote control during playback.

For audible fast reverse:

Press and hold down the ◀◀ button on the main unit or the ◀◀ button on the remote control during playback.

Notes:

- Normal playback will resume when the ◀◀ (◀◀) or ►► (►►) button is released.
- When the end of the last track is reached during fast forward, "END" will appear on the display and CD operation will be paused. When the beginning of the first track is reached during fast reverse, playback will start when you release the ◀◀ button.

■ Repeat play

All tracks or a programmed sequence can be continuously repeated.

To repeat all tracks:

Press the REPEAT button.

To repeat a desired track:

Perform steps 1 - 4 in the "Programmed play" section on page 13 and then press the REPEAT button.



To cancel repeat play:

Press the REPEAT button again.
"◻" will go out.

Caution:

After performing repeat play, be sure to press the ■ button. Otherwise, the disc will play continuously.

■ Random play

The tracks can be played in random order automatically.

Press the RANDOM button to begin random play.

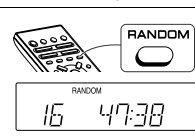

To cancel random play:

Press the RANDOM button again.
"RANDOM" will go out.

Notes:

- The random play will stop automatically when all tracks are played once. (The same track will not be played back twice.)
- In random play, the CD player will select and play tracks automatically. (You cannot select the order of the tracks.)
- If you press the ►► button during random play, you can move to the track selected next by the random operation. On the other hand, the ◀◀ button does not allow you to move to the previous track. The beginning of the track being played will be located.

Programmed play

ENGLISH

You can choose up to 20 selections for playback in the order you like.

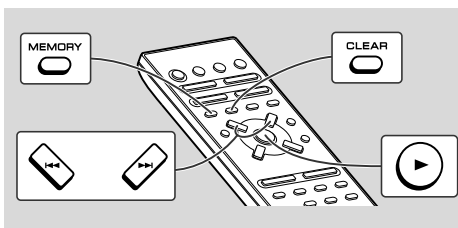

1 Whilst in the stop mode, press the MEMORY (MEMORY/SET) button to enter the programming save mode.



2 Within 30 seconds, press the ◀◀ or ▶▶ button to select the desired track.

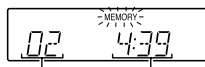

Selected track number Playback time

3 Press the MEMORY (MEMORY/SET) button to save the track number.



Playback order

Total playback time

4 Repeat steps 2 - 3 for other tracks. Up to 20 tracks can be programmed.

5 Press the ▶ (▶||) button to start playback.

To clear the programmed selections:

Press the CLEAR button whilst the "MEMORY" indicator is flashing. Each time the button is pressed, one track will be cleared, beginning with the last track programmed.

To cancel the programmed play mode:

Whilst in the stop mode and the "MEMORY" indicator is lit, press the CLEAR button. The "MEMORY" indicator will disappear and all the programmed contents will be cleared.

Adding tracks to the programme:

If a programme has been previously stored, the "MEMORY" indicator will be displayed. Then follow steps 1 - 3 to add tracks. The new tracks will be stored after the last track of the original programme.

Notes:

- Opening the CD compartment automatically cancels the programmed sequence.
- Even if you press the ON/STAND-BY button to enter the stand-by mode or the function is changed from CD to some other function, the programmed selections will not be cleared.
- During programme operation, random play is not possible.

Listening to the radio

XL-45H

ENGLISH

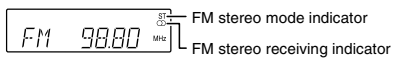
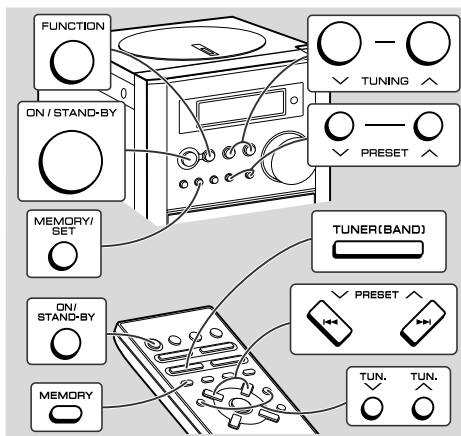

FM stereo mode indicator

FM stereo receiving indicator

- 1 Press the ON/STAND-BY button to turn the power on.**
- 2 Press the FUNCTION button until "FM" or "AM" appears on the display.**
When operating with the remote control, press the TUNER (BAND) button to select "FM" or "AM".

- 3 Press the TUNING (∨ or ∧) button to tune in to the desired station.**

Manual tuning:

Press the TUNING button as many times as required to tune in to the desired station.

Auto tuning:

When the TUNING button is pressed for more than 0.5 seconds, scanning will start automatically and the tuner will stop at the first receivable broadcast station.

Notes:

- This can be operated by pressing the TUN. (∨ or ∧) button on the remote control.
- When radio interference occurs, auto scan tuning may stop automatically at that point.
- Auto scan tuning will skip weak signal stations.
- To stop the auto tuning, press the TUNING button again.
- When an RDS (Radio Data System) station is tuned in, the frequency will be displayed first, and then the RDS indicator will light. Finally, the station name will appear.
- Full auto tuning can be achieved for RDS stations "ASPM", see page 19.

To receive an FM stereo transmission:

Press the FUNCTION (TUNER (BAND)) button to display the "ST" indicator.

- "ST" will appear when an FM broadcast is in stereo.
- If the FM reception is weak, press the FUNCTION (TUNER (BAND)) button to extinguish the "ST" indicator. The reception changes to monaural, and the sound becomes clearer.

After use:

Press the ON/STAND-BY button to enter the power stand-by mode.

Listening to the memorised station

■ Memorising a station

You can store 30 AM and FM stations in memory and recall them at the push of a button. (Preset tuning)

1 Perform steps 1 - 3 in "Listening to the radio" on page 14.

2 Press the MEMORY/SET (MEMORY) button to enter the preset tuning saving mode.

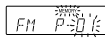

3 Within 5 seconds, press the PRESET (∨ or ∧) button to select the preset channel number.

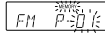

Store the stations in memory, in order, starting with preset channel 1.

4 Within 5 seconds, press the MEMORY/SET (MEMORY) button to store that station in memory.



If the "MEMORY" and preset number indicators go out before the station is memorised, repeat the operation from step 2.

5 Repeat steps 1 - 4 to set other stations, or to change a preset station.

When a new station is stored in memory, the station previously memorised will be erased.

Note:

The backup function protects the memorised stations for a few hours should there be a power failure or the AC power lead disconnection.

■ To recall a memorised station

Press the PRESET (∨ or ∧) button for less than 0.5 seconds to select the desired station.

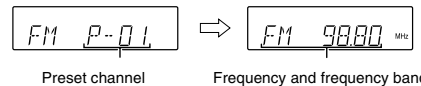

■ To scan the preset stations

The stations saved in memory can be scanned automatically. (Preset memory scan)

1 Press the PRESET (∨ or ∧) button for more than 0.5 seconds.

The preset number will flash and the programmed stations will be tuned in sequentially, for 5 seconds each.

2 Press the PRESET (∨ or ∧) button again when the desired station is located.

■ To clear a memorised station

1 Recall the memorised station.

2 Whilst it is displayed, press the MEMORY/SET (MEMORY) button.

3 Within 5 seconds, press the CLEAR button on the remote control.



Using the Radio Data System (RDS)

RDS is a broadcasting service which a growing number of FM stations provide. These FM stations send additional signals along with their regular programme signals. They send their station names, and information about the type of programme such as sports or music, etc.

When tuned to an RDS station, "RDS" and the station name will be displayed.

"TP" (Traffic Programme) will appear on the display when the received broadcast carries traffic information, and "TA" (Traffic Announcement) will appear whilst a traffic information is on air.

You can control the RDS by using the remote control only.

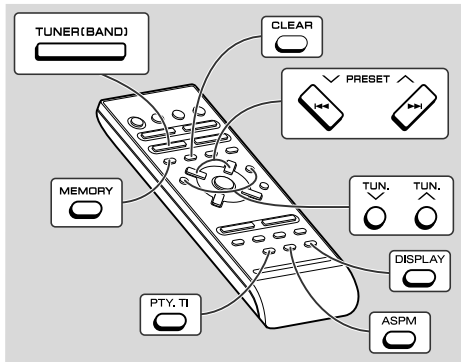

Information provided by RDS

Each time the DISPLAY button is pressed, the display will switch as follows:

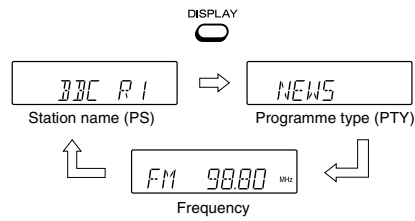

When you are tuning in to a station other than an RDS station or to an RDS station which sends weak signal, the display will change in the following order:

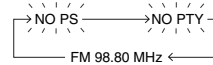

Using the Radio Data System (RDS) (continued)

■ Notes for RDS operation

If any of the following events occur, it does not mean that the unit is faulty:

- "PS", "NO PS" and a station name appear alternately, and the unit does not operate properly.
- If a particular station is not broadcasting properly or a station is conducting tests, the RDS reception function may not work properly.
- When you receive an RDS station whose signal is too weak, information like the station name may not be displayed.
- "NO PS" or "NO PTY" will flash for about 5 seconds, and then the frequency will be displayed.

Descriptions of the **PTY (Programme Type) codes**, **TP (Traffic Programme)** and **TA (Traffic Announcement)**.

You can search for and receive the following PTY, TP and TA signals.

NEWS	Short accounts of facts, events and publicly expressed views, reportage and actuality.
AF-FAIRS	Topical programme expanding or enlarging upon the news, generally in different presentation style or concept, including debate, or analysis.
INFO	Programmes whose purpose is to impart advice in the widest sense.
SPORT	Programme concerned with any aspect of sport.
EDU-CATE	Programme intended primarily to educate, of which the formal element is fundamental.
DRAMA	All radio plays and serials.
CUL-TURE	Programmes concerned with any aspect of national or regional culture, including language, theatre, etc.
SCI-ENCE	Programmes about the natural sciences and technology.
VARIED	Used for mainly speech-based programmes usually of light-entertainment nature, not covered by other categories. Examples include: quizzes, panel games, personality interviews.
POP M	Commercial music, which would generally be considered to be of current popular appeal, often featuring in current or recent record sales charts.
ROCK M	Contemporary modern music, usually written and performed by young musicians.
EASY M	Current contemporary music considered to be "easy-listening", as opposed to Pop, Rock or Classical, or one of the specialised music styles, Jazz, Folk or Country. Music in this category is often but not always, vocal, and usually of short duration.

LIGHT M	Classical music for general, rather than specialist appreciation. Examples of music in this category are instrumental music, and vocal or choral works.
CLAS-SICS	Performances of major orchestral works, symphonies, chamber music, etc., and including Grand Opera.
OTHER M	Musical styles not fitting into any of the other categories. Particularly used for specialist music of which Rhythm & Blues and Reggae are examples.
WEATH-ER	Weather reports and forecasts and meteorological information.
FI-NANCE	Stock Market reports, commerce, trading, etc.
CHIL-DREN	For programmes targeted at a young audience, primarily for entertainment and interest, rather than where the objective is to educate.
SOCIAL	Programmes about people and things that influence them individually or in groups. Includes: sociology, history, geography, psychology and society.
RELI-GION	Any aspect of beliefs and faiths, involving a God or Gods, the nature of existence and ethics.
PHONE IN	Involving members of the public expressing their views either by phone or at a public forum.
TRAV-EL	Features and programmes concerned with travel to near and far destinations, package tours and travel ideas and opportunities. Not for use for announcements about problems, delays, or roadworks affecting immediate travel where TP/TA should be used.
LEI-SURE	Programmes concerned with recreational activities in which the listener might participate. Examples include, Gardening, Fishing, Antique collecting, Cooking, Food & Wine, etc.
JAZZ	Polyphonic, syncopated music characterised by improvisation.

COUN-TRY	Songs which originate from, or continue the musical tradition of the American Southern States. Characterised by a straightforward melody and narrative story line.
NA-TION M	Current Popular Music of the Nation or Region in that country's language, as opposed to International 'Pop' which is usually US or UK inspired and in English.
OLDIES	Music from the so-called "golden age" of popular music.
FOLK M	Music which has its roots in the musical culture of a particular nation, usually played on acoustic instruments. The narrative or story may be based on historical events or people.
DOCU-MENT	Programme concerned with factual matters, presented in an investigative style.
TEST	Broadcast when testing emergency broadcast equipment or receivers.
ALARM	Emergency announcement made under exceptional circumstances to give warning of events causing danger of a general nature.
NONE	No programme type (receive only).
TP	Broadcasts which carry traffic announcements.
TA	Traffic announcements are being broadcast.

Using the Radio Data System (RDS) (continued)

■ Using the Auto Station Programme Memory (ASPM)

Whilst in the ASPM operation mode, the tuner will automatically search for new RDS stations. Up to 30 stations can be stored. If you have already stored some stations in memory, the number of new stations you can store will be less.

1 Press the TUNER (BAND) button to select "FM".

TUNER(BAND)

2 Press and hold down the ASPM button for at least 3 seconds.

- ASPM 1 After "ASPM" has flashed for about 4 seconds, scanning will start (87.50 - 108.00 MHz).

  → 

- 2 When an RDS station is found, "RDS" will appear first, and then "MEMORY" and the preset channel number will flash for 2 seconds. Finally the station will be stored in memory.

 → 

- 3 After scanning, the number of stations stored in memory will be flash for 4 seconds.

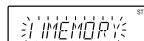

To stop the ASPM operation before it is complete:

Press the ASPM button whilst it is scanning for stations. The stations which are already stored in memory will be kept there.

Notes:

- If the same station is broadcasting on different frequencies, the strongest frequency will be stored in memory.
- Any station which has the same frequency as the one stored in memory will not be stored.
- If 30 stations have already been stored in memory, the scan will be aborted. If you want to redo the ASPM operation, erase the preset memory.
- If no stations have been stored in memory, "OMEMORY" will appear for about 4 seconds.
- If the RDS signals are very weak, station names may not be stored in memory.

To erase one of the contents of preset memory:

- 1 Press the PRESET (∨ or ^) button to select the preset channel number you want to erase.
- 2 Press the MEMORY button.
- 3 Within 5 seconds, press the CLEAR button.

To erase all of the contents of preset memory:

Refer to "Clearing all the memory (reset)" on page 29.

To store a station name again if the wrong name was stored in memory:

It may be impossible to store station names in memory using the ASPM function if there is lots of noise or if the signal is too weak. In this case, perform as follows.

- 1 Press the PRESET (∨ or ^) button to check whether the names are correct.
 - 2 If you find a wrong name during receiving the station. Wait until the correct name will be displayed. And then press the MEMORY button.
 - 3 Within 5 seconds, press the MEMORY button whilst the preset channel number is flashing.
- The new station name has been stored in memory correctly.

Notes:

- The same station name can be stored in different channels.
- In a certain area or during certain time periods, the station names may temporarily be different.

■ To recall stations in memory

To specify programmed types and select stations (PTY search):
You can search a station by specifying the programme type (news, sports, traffic programme, etc. ... see page 17) from the stations in memory.

1 Press the TUNER (BAND) button to select "FM".

2 Press the PTY.TI button.



"PTY TI" will flash for about 4 seconds.

3 Within 4 seconds, press the PRESET (∨ or ∧) button to select the programme type.



Each time the button is pressed, the programme type will appear. If the button is held down for more than 0.5 seconds, the programme type will appear continuously.

4 Whilst the selected programme type is flashing (within 4 seconds), press the PTY.TI button again.



After the selected programme type has been lit for 2 seconds, "SEARCH" will appear, and the search operation will start.

Notes:

- If the display has stopped flashing, start again from step 2. If the unit finds a desired programme type, the corresponding channel number will flash for about 4 seconds which the station name will flash for 7 seconds which will remain lit.
- If you want to listen to the same programme type of another station, press the PTY.TI button whilst the channel number or station name is flashing. The unit will look for the next station.
- If no station can be found, "NOT FOUND" will appear for 4 seconds.

If you select the traffic programme:

If you select the traffic programme (TP) in step 3, "TP" will appear. (This does not mean that you can listen to the traffic information at that time.)

When a traffic information is broadcast, "TA" will appear.

To specify station names and select stations manually:

You can select a station by specifying the name (BBC R1, BBC R2, etc.) from the stations stored in memory.

Before starting this operation, you must store one or more station names in memory.

- 1 Press the TUNER (BAND) button to select the FM band.
- 2 Press the PRESET (∨ or ∧) button to select a desired station.
- 3 The station name will be displayed for 3 seconds. Then the display will change.

Listening to a cassette tape



ENGLISH

Tape Playback

Before playback:

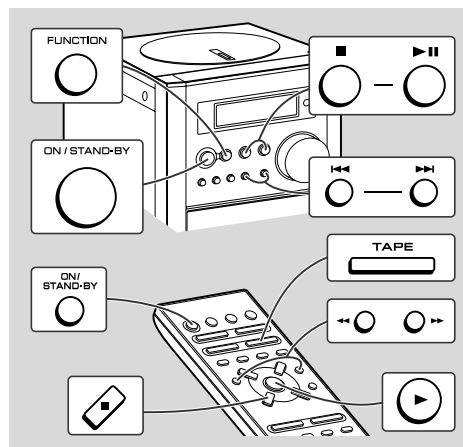
- For playback, use normal or low-noise tapes for the best sound. (Metal or CrO₂ tapes are not recommended.)
- Do not use C-120 tapes or poor-quality tapes, as they may cause malfunctions.
- Before loading a tape into the cassette compartment, tighten the slack with a pen or a pencil.



- 1 Press the ON/STAND-BY button to turn the power on.**
- 2 Press the FUNCTION button until "TAPE" appears on the display.**
When operating with the remote control, press the TAPE button.
- 3 Open the cassette compartment by pushing the area marked "PUSH EJECT ▲".**

- 4 Load a cassette into the cassette compartment with the side to be played facing toward you.**

- 5 Close the cassette compartment by pushing the area marked "PUSH EJECT ▲".**
- 6 Press the ►II button to start playback.**
When playback is performed using the remote control, press the ► button.

To stop playback:

Press the ■ button.

Fast forward/rewind:

To advance the tape, press the ►► button on the main unit or the ►► button on the remote control. To rewind it, press the ◀◀ button on the main unit or the ◀◀ button on the remote control.

Caution:

- To remove the cassette, press the ■ button, and then open the compartment.
- Before changing from one tape operation to another, press the ■ button.
- If a power failure occurs during tape operation, the tape head will remain engaged with the tape and the cassette compartment will not open. In this case, wait until the power is restored.
- Even if the ►|| (II) button is pressed during tape playback, the unit will not enter the pause mode.

Recording to a cassette tape

ENGLISH

Tape Recording

Before recording:

- When recording important selections, make a preliminary test to ensure that the desired material is properly recorded.
- SHARP is not liable for damage or loss of your recording arising from malfunction of this unit.
- The volume and sound controls can be adjusted with no effect on the recorded signal (Variable Sound Monitor).
- **For recording, use only normal tapes. Do not use metal or CrO₂ tapes.**

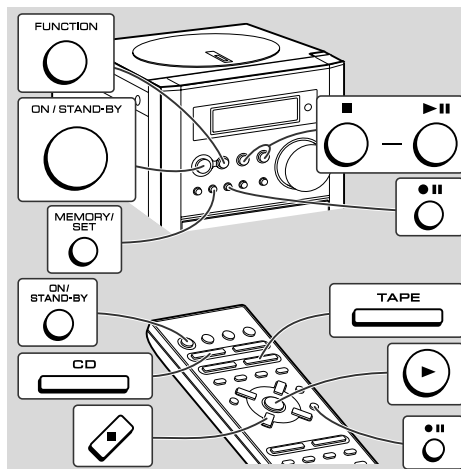

Recording from a CD

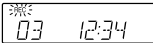
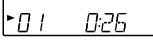
- 1 Press the ON/STAND-BY button to turn the power on.**
- 2 Press the FUNCTION button until "CD STOP" appears on the display.**
When operating with the remote control, press the CD button.
- 3 Load the desired disc.**
- 4 Load a cassette into the cassette compartment with the side to be recorded on facing you.**
Wind past the leader of the tape, on which recording cannot be performed.
- 5 Press the ●|| button.**
Recording will be paused.

- 6 Press the ►|| (►) button.**

 - CD playback will start in a few seconds after the tape starts.
 - When the playback of the disc is finished, the CD and the cassette will stop automatically.

To perform programmed recording:

- 1 Programme tracks (see page 13).
- 2 Press the ●|| button.
- 3 Press the ►|| (►) button.

To interrupt recording:**Main unit operation:**

Press the **II** button.

To resume recording, press the **▶II** button.

Remote control operation:

Press the **II** button.

To resume recording, press the **▶** button.

To stop recording:

Press the **■** button.

The tape will stop. When the **■** button is pressed again, the CD will stop.

■ Recording from the radio

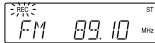
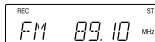
1	Tune in to the desired station (see page 14).	
2	Load a cassette into the cassette compartment with the side to be recorded on facing you.	
	Wind past the leader of the tape, on which recording cannot be performed.	
3	Press the II button.	
	Recording will be paused.	
4	Press the ▶II (▶) button.	

To stop recording:

Press the **■** button.

Notes:

- If you hear a whistling noise whilst recording an AM station, move the AM loop aerial.
- Whilst recording from the radio, the recording pause function does not work.

■ Erasing a recorded tape

1. Load the tape to be erased into the cassette compartment with the side to be erased facing toward you.
2. Press the FUNCTION button until "TAPE" appears on the display.
3. When operating with the remote control, press the TAPE button.
4. Press the **II** button.
5. Press the **▶II** (**▶**) button to start erasing.

Erase-prevention tabs of cassette tapes:

- When recording on a cassette tape, make sure that the erase-prevention tabs are not removed. Cassettes have removable tabs that prevent accidental recording or erasing.
- To protect the recorded sound, remove the tab after recording. Cover the tab hole with the adhesive tape to record on the tape without the tab.

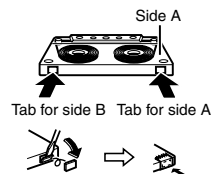

Timer and sleep operation

ENGLISH

Advanced Features

This may be operated only with the remote control.

Timer playback:

The unit turns on and plays the desired source (CD, tuner, tape) at the preset time.

Sleep operation:

The radio, compact disc and cassette tape can all be turned off automatically.

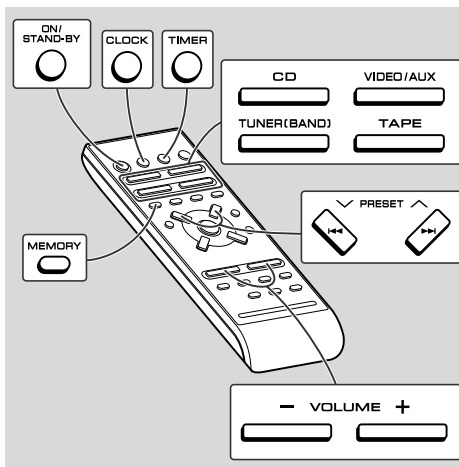

■ Timer playback

Before setting timer:

- 1 Press the CLOCK button to check that the clock is set to the correct time.
- 12:30
- 2 Load a cassette or disc to be played.



- 1 Press the ON/STAND-BY button to turn the power on.
 - 2 Press the CD, TUNER (BAND) or TAPE button to select the desired function.
If you select TUNER (BAND), tune in to the desired station.
 - 3 Adjust the volume using the VOLUME buttons.
Do not turn the volume up too high.
 - 4 Press the TIMER button and within 6 seconds, press the MEMORY button.
- :00:00 → :00:00
- 5 Within 1 minute, press the PRESET (∨ or ∧) button to specify the hour to start, then press the MEMORY button.
- :00:00 → 8:00

6 Within 1 minute, press the PRESET (∨ or ∧) button to specify the minutes to start, then press the MEMORY button.

- The timer playback starting time, function, and volume will be displayed, and then the unit will enter the stand-by mode automatically.
- "00" will appear and the current time will be displayed.



To cancel the timer playback:

Press the ON/STAND-BY button to turn the power on.

7 When the preset time is reached, playback will start.

The volume will increase gradually until it reaches the volume you were listening at before your system enters the timer stand-by mode.

8 The unit will enter the stand-by mode one hour after the timer playback starts. However, when CD or tape playback time is one hour or less, it will enter the stand-by mode after completing playback.

To reset or change the timer setting:

Perform "Timer playback" from the beginning.

Note:

When performing timer playback using another unit connected to the VIDEO/AUX IN sockets, select "VIDEO/AUX" in step 2. At this time, only this unit will be turned on or enter the power stand-by mode automatically. It will enter the power stand-by mode 1 hour after the timer playback starts. (Another unit will not be turned on or off.)

■ **Sleep operation**

1 Play back the desired sound source.

2 Press the SLEEP button.



To change the sleep time:

Press the SLEEP button repeatedly to select the desired sleep time. The time will decrease as follows.

The amount of sleep time can also be changed whilst in the sleep mode.

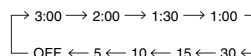

3 Your system will enter the power stand-by mode automatically after the preset time has elapsed.

The volume will be turned down 1 minute before the sleep operation finishes.

To cancel the sleep operation:

Press the ON/STAND-BY button whilst "SLEEP" is indicated.

To cancel the sleep operation without setting the system to the stand-by mode, press the SLEEP button until "OFF" appears on the display.

To confirm the remaining sleep time:

Press the SLEEP button once whilst the sleep timer is set.

The remaining sleep time is displayed for about 3 seconds.

■ To use timer and sleep operation together

Example: To fall asleep and wake to the same radio station
You can play back the same source only (the function cannot be switched).

1 Set the sleep time (steps 1 - 2, page 26).

2 Whilst the sleep timer is set, set the desired playback time (steps 4 - 6, pages 25 - 26).

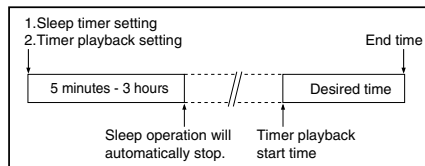

Caution:

When using the cassette deck, be sure the tape length is long enough to perform both functions. If you want to sleep and wake up listening to a tape, and the length of the tape is shorter than the sleep timer setting, timer playback will not be possible.

Enhancing your system

The connection lead is not included. Purchase a commercially available lead as shown below.

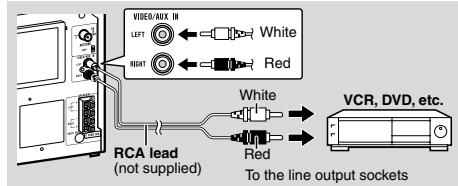

■ Listening to the playback sounds from VCR, DVD, etc.

- 1 Use a connection lead to connect the VCR, DVD, etc. to the VIDEO/AUX IN sockets.
When using video equipment, connect the audio output to this unit and the video output to a television.
- 2 Press the ON/STAND-BY button to turn the power on.
- 3 Press the FUNCTION button until "AUX" appears on the display.
When operating with the remote control, press the VIDEO/AUX button.
- 4 Play the VCR, DVD, etc.

Note:

To prevent hum interference, place this unit away from a television.

■ To record on a tape from VCR etc.

- 1 Load a cassette into the cassette compartment with the side to be recorded on facing you.
- 2 Press the VIDEO/AUX button.
- 3 Press the **●||** button.
- 4 Press the **▶||** button.
- 5 Play back the VCR etc.

Troubleshooting chart

Many potential problems can be resolved by the owner without calling a service technician. If something is wrong with this product, check the following before calling your authorised SHARP dealer or service centre.

■ General

Symptom	Possible cause
The clock is not set to the correct time.	<ul style="list-style-type: none"> Did a power failure occur? Reset the clock (refer to page 9).
When a button is pressed, the unit does not respond.	<ul style="list-style-type: none"> Set this unit to the power stand-by mode and then turn it back on. If the unit still malfunctions, reset it. (Refer to page 29.)
No sound is heard.	<ul style="list-style-type: none"> Is the volume level set to "MIN"? Are the headphones connected? Are the speaker wires disconnected?

■ CD player

Playback does not start.	<ul style="list-style-type: none"> Is the disc loaded upside down?
Playback stops in the middle or is not performed properly.	<ul style="list-style-type: none"> Does the disc satisfy the standards? Is the disc distorted or scratched?
Playback sounds are skipped, or stopped in the middle of a track.	<ul style="list-style-type: none"> Is the unit located near excessive vibrations? Is the disc very dirty? Has condensation formed inside the unit?

■ Tuner

The radio makes unusual noises continuously.	<ul style="list-style-type: none"> Is the unit placed near the TV or computer? Is the FM or AM aerial placed properly? Move the aerial away from the AC power lead if located near.
--	---

■ Cassette deck

Cannot record.	<ul style="list-style-type: none"> Is the erase-prevention tab removed?
Cannot record tracks with proper sound quality.	<ul style="list-style-type: none"> Is it a normal tape? (You cannot record on a metal or CrO₂ tape.)
Cannot erase completely.	
Sound skipping.	<ul style="list-style-type: none"> Is there any slack?
Cannot hear treble.	<ul style="list-style-type: none"> Is the tape stretched?
Sound fluctuation.	<ul style="list-style-type: none"> Are the capstan, pinch roller, or heads dirty?
Cannot remove the tape.	<ul style="list-style-type: none"> If a power failure occurs during playback, the heads remain engaged with the tape. Do not open the compartment forcibly. Wait until electricity resumes.

■ Remote control

The remote control does not operate.	<ul style="list-style-type: none"> Is the AC power lead of the unit plugged in? Is the battery polarity correct? Are the batteries dead? Is the distance or angle incorrect? Does the remote control sensor receive strong light?
--------------------------------------	--

■ If trouble occurs

When this product is subjected to strong external interference (mechanical shock, excessive static electricity, abnormal supply voltage due to lightning, etc.) or if it is operated incorrectly, it may malfunction.

If such a problem occurs, do the following:

- 1 Set the unit to the stand-by mode and turn the power on again.
- 2 If the unit is not restored in the previous operation, unplug and plug in the unit, and then turn the power on.

Note:

If neither operation above restores the unit, clear all the memory by resetting it.

■ Clearing all the memory (reset)

- 1 Press the ON/STAND-BY button to enter the power stand-by mode.
- 2 Unplug the AC power lead from the AC INPUT socket on the unit.
- 3 Whilst pressing down the MEMORY/SET button and the  button, plug the AC power lead into the AC INPUT socket on the unit.

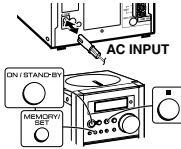

Caution:

This operation will erase all data stored in memory including clock, timer settings, tuner preset, and CD programme.

■ Condensation

Sudden temperature changes, storage or operation in an extremely humid environment may cause condensation inside the cabinet (CD pickup, tape heads, etc.) or on the transmitter on the remote control. Condensation can cause the unit to malfunction. If this happens, leave the power on with no disc (or cassette) in the unit until normal playback is possible (about 1 hour). Wipe off any condensation on the transmitter with a soft cloth before operating the unit.

Maintenance

■ Cleaning the CD pickup lens

Do not touch the laser pickup lens. If fingerprints or dust accumulate on the pickup, clean it gently with a dry cotton swab.



■ Cleaning the cabinet

Periodically wipe the cabinet with a soft cloth and a diluted soap solution, then with a dry cloth.

Caution:

- Do not use chemicals for cleaning (petrol, paint thinner, etc.). It may damage the cabinet finish.
- Do not apply oil to the inside of the unit. It may cause malfunctions.

■ Cleaning the tape-handling parts

- Dirty heads, capstan or pinch roller can cause poor sound and tape jams. Clean these parts with a cotton swab moistened with commercial head/pinch roller cleaner or isopropyl alcohol.
- When cleaning the heads, pinch roller, etc., unplug the unit which contains high voltages.

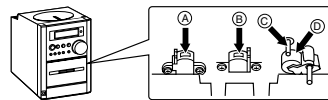

- A Erase head C Capstan
B Recording/Playback head D Pinch roller head

- After long use, the deck's heads and capstan may become magnetised, causing poor sound. Demagnetise these parts once every 30 hours of playing/recording time by using a commercial tape head demagnetiser. Read the demagnetiser's instructions carefully before use.

Specifications

As part of our policy of continuous improvement, SHARP reserves the right to make design and specification changes for product improvement without prior notice. The performance specification figures indicated are nominal values of production units. There may be some deviations from these values in individual units.

■ General

Power source	AC 230 V, 50 Hz
Power consumption	Power on: 26 W Power stand-by: 0.9 W
Dimensions	Width: 160 mm (6-5/16") Height: 240 mm (9-1/2") Depth: 247 mm (9-3/4")
Weight	2.6 kg (5.8 lbs.)

■ Amplifier

Output power	PMPO: 30 W (total) MPO: 15 W (7.5 W + 7.5 W) (DIN 45 324) RMS: 10 W (5 W + 5 W) (DIN 45 324)
Output terminals	Speakers: 4 ohms Headphones: 16 - 50 ohms (recommended: 32 ohms)
Input terminals	Video/Auxiliary (audio signal): 500 mV/47 k ohms

■ Tuner

Frequency range	FM: 87.5 - 108 MHz AM: 522 - 1,620 kHz
------------------------	---

■ CD player

Type	Compact disc player
Signal readout	Non-contact, 3-beam semiconductor laser pickup
D/A converter	1-bit D/A converter
Frequency response	20 - 20,000 Hz
Dynamic range	90 dB (1 kHz)

■ Cassette deck

Frequency response	50 - 14,000 Hz (normal tape)
Signal/noise ratio	50 dB (recording/playback)
Wow and flutter	0.3 % (DIN 45 511)

■ Speaker

Type	10 cm (4") full-range speaker
Maximum input power	10 W
Rated input power	5 W
Impedance	4 ohms
Dimensions	Width: 145 mm (5-3/4") Height: 240 mm (9-1/2") Depth: 175 mm (6-15/16")
Weight	1.4 kg (3.1 lbs./each)

XL-45H

ENGLISH

References

E-30

8

02/10/1

XL_45H_H_E4.fm

SHARP
SHARP CORPORATION

TINSZ0173SJZZ
02K N HK ②

↑
UP

DOWN

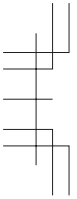

XL-45H MICRO COMPONENT SYSTEM SHARP

