

Installation and Operation Manual

BLE*/*
Broadband Line Extender

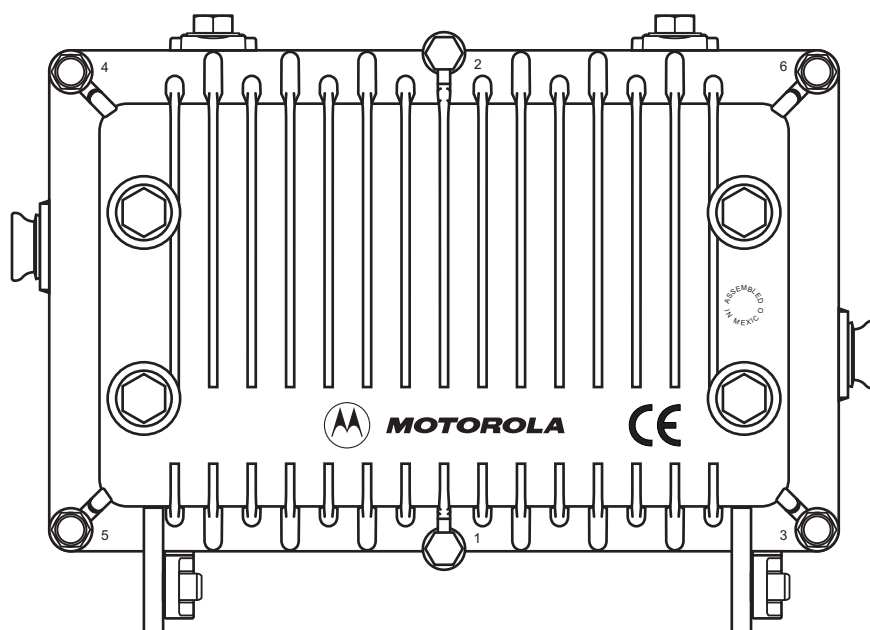



MOTOROLA
intelligence everywhere™



Caution

These servicing instructions are for use by qualified personnel only. To reduce the risk of electrical shock, do not perform any servicing other than that contained in the Installation and Troubleshooting Instructions unless you are qualified to do so. Refer all servicing to qualified service personnel.

Special Symbols That Might Appear on the Equipment

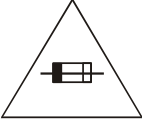
	This symbol indicates that dangerous voltage levels are present within the equipment. These voltages are not insulated and may be of sufficient strength to cause serious bodily injury when touched. The symbol may also appear on schematics.
	The exclamation point, within an equilateral triangle, is intended to alert the user to the presence of important installation, servicing, and operating instructions in the documents accompanying the equipment.
	For continued protection against fire, replace all fuses only with fuses having the same electrical ratings marked at the location of the fuse.

FCC Compliance

This equipment has been tested and found to comply with the limits for a Class A digital device, pursuant to Part 15 of the FCC Rules. These limits are designed to provide reasonable protection against harmful interference when the equipment is operated in a commercial environment. This equipment generates, uses, and can radiate radio frequency energy and, if not installed and used in accordance with the Installation Manual, may cause harmful interference to radio communications. Operation of this equipment in a residential area is likely to cause harmful interference in which case the user will be required to correct the interference at his/her own expense. Any changes or modifications not expressly approved by Motorola could void the user's authority to operate this equipment under the rules and regulations of the FCC.

Canadian Compliance

This Class A digital apparatus meets all requirements of the Canadian Interference-Causing Equipment Regulations.
Cet appareil numérique de la classe A respecte toutes les exigences du Règlement sur le matériel brouilleur du Canada.

Declaration of Conformity				
We	Motorola, Inc. 101 Tournament Drive Horsham, PA 19044, U.S.A.			
declare under our sole responsibility that the	Model BLE*/*			
STARLINE	Model BLE*/*			
to which this declaration relates is in conformity with one or more of the following standards:				
EMC Standards	EN55022	EN55024	EN50083-2	CISPR-22 CISPR-24
Safety Standards	EN60065	EN60825	EN60950	IEC 60950 + A1: 1992 + A2: 1993 + A3: 1995 + A4: 1996
following the provisions of the Directive(s) of the Council of the European Union:				
EMC Directive 89/336/EEC	Low Voltage Directive 73/23/EEC			

Copyright © 2004 by Motorola, Inc.

All rights reserved. No part of this publication may be reproduced in any form or by any means or used to make any derivative work (such as translation, transformation or adaptation) without written permission from Motorola, Inc.

Motorola reserves the right to revise this publication and to make changes in content from time to time without obligation on the part of Motorola to provide notification of such revision or change. Motorola provides this guide without warranty of any kind, either implied or expressed, including, but not limited to, the implied warranties of merchantability and fitness for a particular purpose. Motorola may make improvements or changes in the product(s) described in this manual at any time.

MOTOROLA and the Stylized M Logo are registered in the US Patent & Trademark Office. All other product or service names are the property of their respective owners. © Motorola, Inc. 2004

Contents

Section 1

Introduction

Using This Manual	1-3
Related Documentation	1-3
Document Conventions	1-3
If You Need Help.....	1-4
Calling for Repairs	1-5

Section 2

Overview

Configuration.....	2-2
Housing.....	2-3
Gaskets	2-4
Port Locations	2-5
Power Supply	2-6
Forward Path	2-7
Return Path.....	2-7
Ingress Control Switch.....	2-8
Options and Accessories	2-8

Section 3

Amplifier Setup

Forward Path Alignment.....	3-1
Before You Begin	3-1
Cable Equalizer.....	3-2
Example 1.....	3-2
Example 2.....	3-2
STARLINE Cable Simulators.....	3-5
Input and Midstage Pads.....	3-6
Flatness Control	3-6
Directional Coupler Test Points.....	3-8
Bode Equalization	3-8
Amplifier Level Control.....	3-9
Manual Gain Control	3-9
Thermal Drive Unit.....	3-10
Automatic Drive Unit.....	3-11
ADU Pads and Levels	3-12

Return Path Alignment.....	3-12
Before You Begin.....	3-12
Alignment Procedure	3-13
Powering and Surge Protection	3-14

Section 4

Bench Testing

Before You Begin.....	4-1
Test Equipment and Connections	4-2
Measuring Forward Gain.....	4-2
Example:	4-3
Example:	4-3
Testing Return Gain and Response.....	4-4
Example:	4-4
Completing the Test Procedures	4-4

Section 5

Installation

Aerial Installation.....	5-1
Pedestal Installation	5-3

Section 6

Operating Tips

Using Amplifiers in Lower Frequency Systems	6-1
Using Amplifiers in Lower Gain Systems	6-1

Appendix A

Specifications

Model BLE87S/H*	A-1
Model BLE87S/G*	A-2
AC Current.....	A-2
RA-Kit/L Return Amplifier	A-3
ADU Automatic Drive Unit	A-3

Appendix B

Torque Specifications

Abbreviations and Acronyms

Figures

Figure 1-1 BLE*/* - closed	1-1
Figure 1-2 BLE*/* - open	1-2
Figure 2-1 BLE*/* base with electronics module.....	2-1
Figure 2-2 BLE*/* configurator.....	2-2
Figure 2-3 BLE-HSG/15 housing and dimensions	2-3
Figure 2-4 Housing gaskets	2-4
Figure 2-5 Housing ports.....	2-5
Figure 2-6 BLE*/* power supply.....	2-6
Figure 2-7 BLE*/* block diagram	2-7
Figure 2-8 BLE*/* options and accessories.....	2-10
Figure 3-1 Equalizer slope versus cable.....	3-4
Figure 3-2 Frequency versus cable slope	3-6
Figure 3-3 8LDR*//III component layout (top-left, bottom-right).....	3-7
Figure 3-4 Typical flatness and control ranges	3-8
Figure 3-5 TDU cable selector	3-10
Figure 3-6 ADU	3-11
Figure 4-1 Test equipment connections for bench sweeping.....	4-2
Figure 5-1 Center-conductor pin length	5-1
Figure 5-2 Torque sequence	5-2

Tables

Table 2-1 BLE*/* options and accessories	2-8
Table 3-1 Starline Forward Equalizers – SFE*-*.....	3-3
Table 3-2 STARLINE Cable Simulators	3-5
Table 3-3 Gain reserve versus ambient temperature	3-9
Table 3-4 BLE*/* AGC pad levels.....	3-12

Section 1 Introduction

The Motorola STARLINE® series of broadband line extenders, BLE*/*, accept a single input and provide 28 through 32 dB of operational gain (depending on model) to a single output. The BLE*/* series of line extenders meets Telcordia GR-1098 core voltage surge requirements using surge waveforms as described in IEEE C62.41. The BLE*/* is also FCC, CE, and CCC approved.

Features of the BLE*/* include:

- 870 MHz power doubling technology in enhanced gallium arsenide (E-GaAs)
- Five different modular diplex filter splits
- “Ease of use” ergonomics
- 60/90 Vac line power option
- Thermal and auto-controlled Bode equalization
- -20 dB directional coupler test points
- Optional return path ingress control and LIFELINE® status monitor
- Two-way operation capability
- 15-amp power passing

Figure 1-1 illustrates a closed BLE*/* line extender:

Figure 1-1
BLE*/* - closed

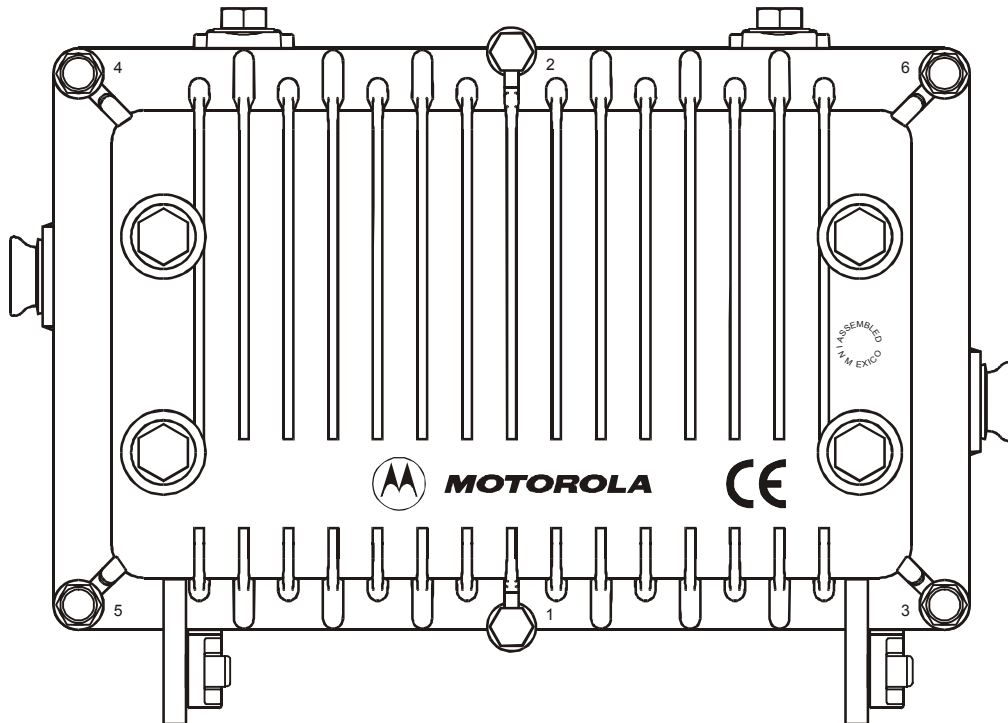
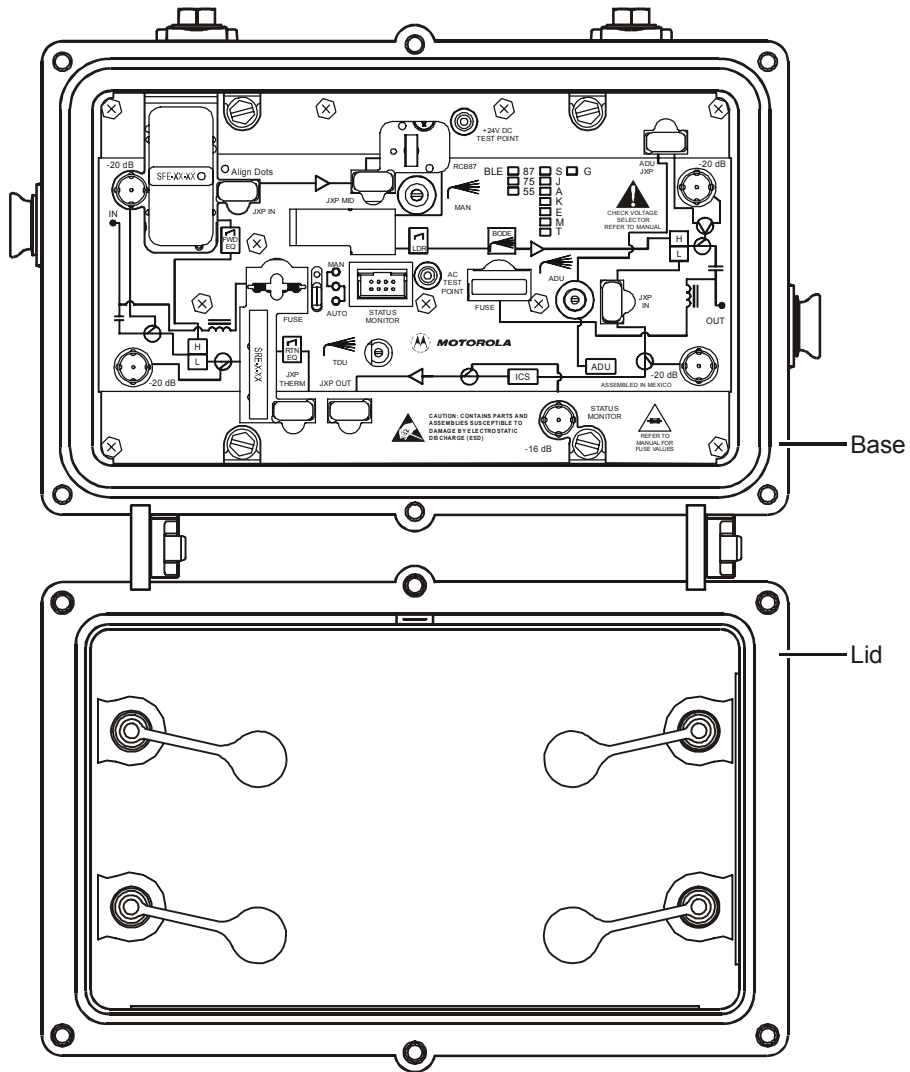

Figure 1-2 illustrates an open BLE*/*::

Figure 1-2
BLE*/* - open



Using This Manual

The following sections provide information and instructions to bench test, install, and operate the BLE*/*.

Section 1	Introduction provides a brief description of the product, identifies the information contained in this manual, and gives the help line telephone number and repair return information.
Section 2	Overview describes the BLE*/* and includes details on the various options and their functions.
Section 3	Amplifier Setup provides instructions for full configuration and forward- and return-path alignment.
Section 4	Bench Testing describes the bench test procedures that are recommended before installing the BLE*/*.
Section 5	Installation provides instructions for installing the BLE*/* and performing field alignment.
Section 6	Operating Tips provides suggestions for handling field-encountered variables and addressing maintenance tasks.
Appendix A	Specifications lists the applicable technical specifications for the BLE*/* and options.
Appendix B	Torque Specifications provides the appropriate torque specifications for the screws, clamps, connectors, and bolts used in the BLE**.
Abbreviations and Acronyms	The Abbreviations and Acronyms list contain the full spelling of the short forms used in this manual.

This installation manual assumes that all channels are standard National Television Standards Committee (NTSC) analog channels. Refer to catalog specifications for further details pertaining to signal levels of digital channels above 550 MHz.

This installation manual uses 870 MHz as the reference frequency unless another frequency is given. For example, quoted cable loss is understood to be at 870 MHz.

Related Documentation

This installation manual is complete and you should not require any additional documentation to install, test, or operate the BLE*/* line extender.

Document Conventions

Before you begin to use the BLE*/*, familiarize yourself with the stylistic conventions used in this manual:

Bold type	Indicates text that you must type exactly as it appears or indicates a default value
SMALL CAPS	Denotes silk screening on the equipment, typically representing front and rear-panel controls, I/O connections and indicators (LEDs).
* (Asterisk)	Indicates that there are several versions of the same model number and the information applies to all models. When the information applies to a specific model, the complete model number is given.
<i>Italic type</i>	Denotes a displayed variable, a variable that you must type, or is used for emphasis

If You Need Help

If you need assistance while working with the BLE**/, contact the Motorola Technical Response Center (TRC):

- Inside the U.S.: 1-888-944-HELP (1-888-944-4357)
- Outside the U.S.: **215-323-0044**
- Motorola Online: <http://businessonline.motorola.com>

The TRC is open from 8:00 AM to 7:00 PM Eastern Time, Monday through Friday and 10:00 AM to 5:00 PM Eastern Time, Saturday. When the TRC is closed, emergency service *only* is available on a call-back basis. Motorola Online offers a searchable solutions database, technical documentation, and low priority issue creation/tracking 24 hours per day, 7 days per week.

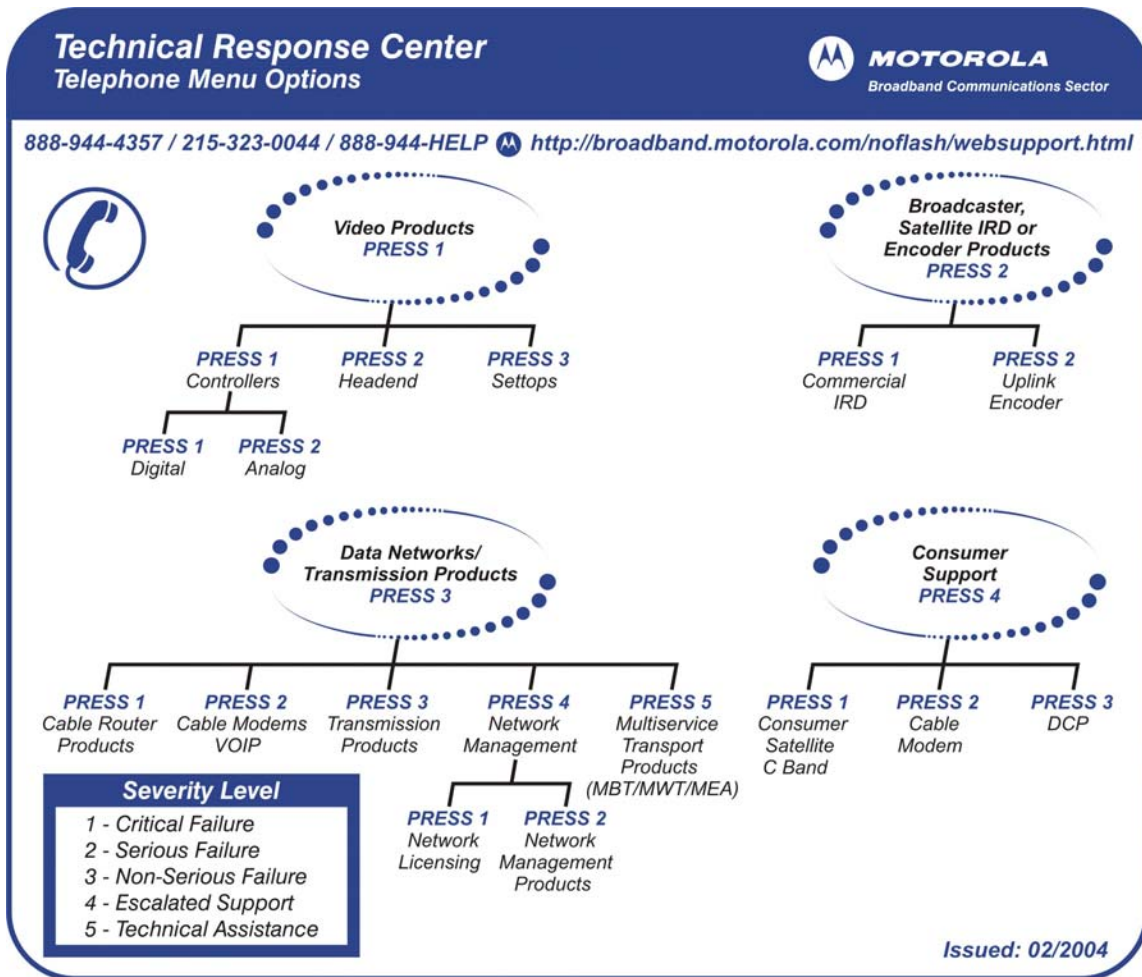

Calling for Repairs

If repair is necessary, call the Motorola Repair Facility at **1-800-642-0442** or e-mail nogrepaircenter@motorola.com for a Return for Service Authorization (RSA) number before sending the unit. The RSA number must be prominently displayed on all equipment cartons. The Repair Facility is open from 7:00 AM to 4:00 PM Pacific Time, Monday through Friday.

When calling from outside the United States, use the appropriate international access code, and then call **52-631-311-1100** to contact the Repair Facility.

When shipping equipment for repair, follow these steps:

- 1 Pack the unit securely.
- 2 Enclose a note describing the exact problem.
- 3 Enclose a copy of the invoice that verifies the warranty status.
- 4 Ship the unit **PREPAID** to the following address:

Motorola, Inc.
Broadband Communications Sector
c/o Excel
Attn: RSA # _____
6908 East Century Park Drive
Suite 100
Tucson, AZ 85706

Configuration

The BLE*/* is fully configured in the Motorola factory per customer request. It is recommended that you verify the configuration listed on the outside of the shipping carton with the configuration you ordered. The shipped configuration is also noted on labels located on the side of the housing and the side of the electronics module.

Figure 2-2
BLE*/* configurator

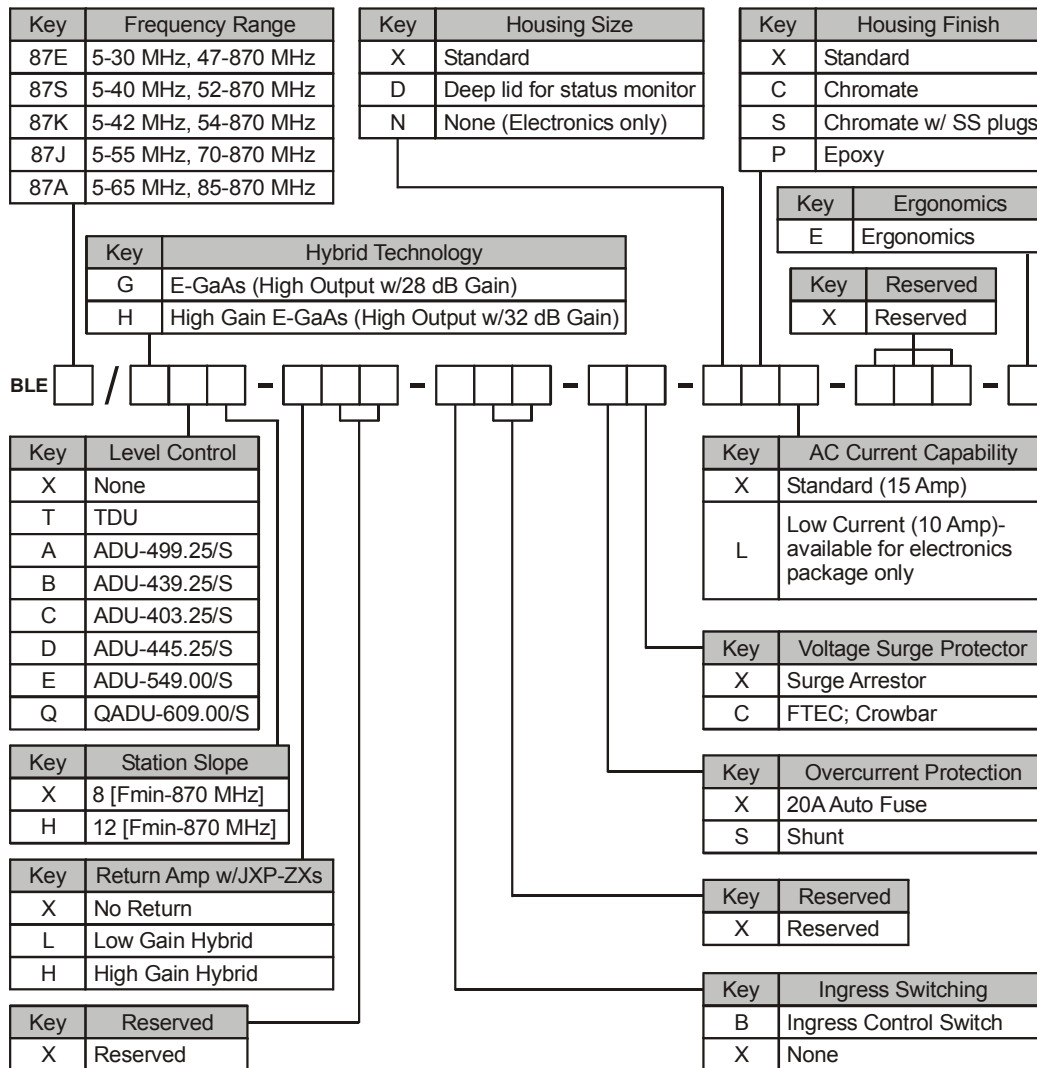

Housing

The BLE^{*/*} is furnished in a BLE-HSG/15 aluminum housing that protects the electronics from weather and dissipates internally generated heat.

Figure 2-3 illustrates the BLE-HSG/15 housing and provides its dimensions:

Figure 2-3
BLE-HSG/15 housing and dimensions

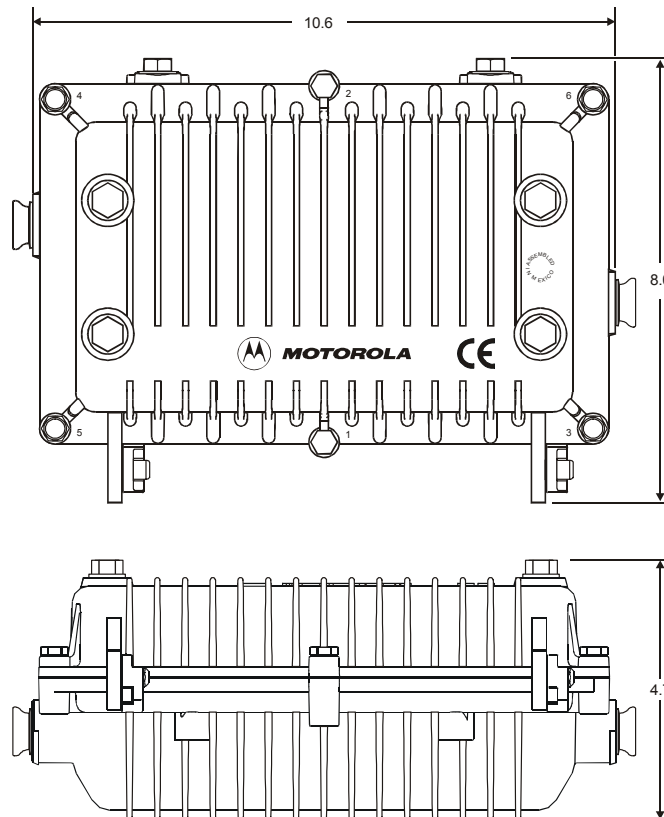

Coaxial cable connections to the housing are made using conventional 5/8 inch \times 24 threads per-inch stinger-type connectors. Four port plugs in the cover enable access to internal test points without opening the housing.

The BLE-HSG/15 differs from the housing of the 10A BLE (model BLE-75SH and BLE-75JH) and the JLX series of line extenders. However, you can upgrade the 10A BLE and the JLX series of line extenders to the 15A BLE^{*/*} using the existing housing. To upgrade from 10A to 15A, use the BLE-15A platform assembly kit (P/N 951941-006-00). The BLE-15A kit contains 15A platform assemblies. As an alternative to the kit, you can order the current BLE^{*/*} electronics module configured as a 10A unit (see Fig.2-2 BLE^{*/*} Configurator, AC Current Capability).

Two messenger clamps are located in the side of the housing (Figure 2-5) and are secured with 5/16 inch \times 24 threads-per-inch stainless steel bolts. The bottom of the housing also contains two 5/16 \times 24 threaded holes located on the vertical center-line separated by four inches center-to-center. Use these holes and the bolts from the messenger clamps for pedestal and surface-mounting installations.

Gaskets

Each housing is equipped with a recessed woven-wire RF gasket and a silicone-rubber gasket to provide a seal between the housing base and lid. These gaskets provide efficient ground continuity, RF shielding, and weather protection. Both gaskets must be in place and in good condition to ensure proper operation and protection of the station. The weather gasket should be lightly coated with silicone grease each time the BLE** is opened. Replace this gasket if it becomes damaged or deformed.

Figure 2-4
Housing gaskets

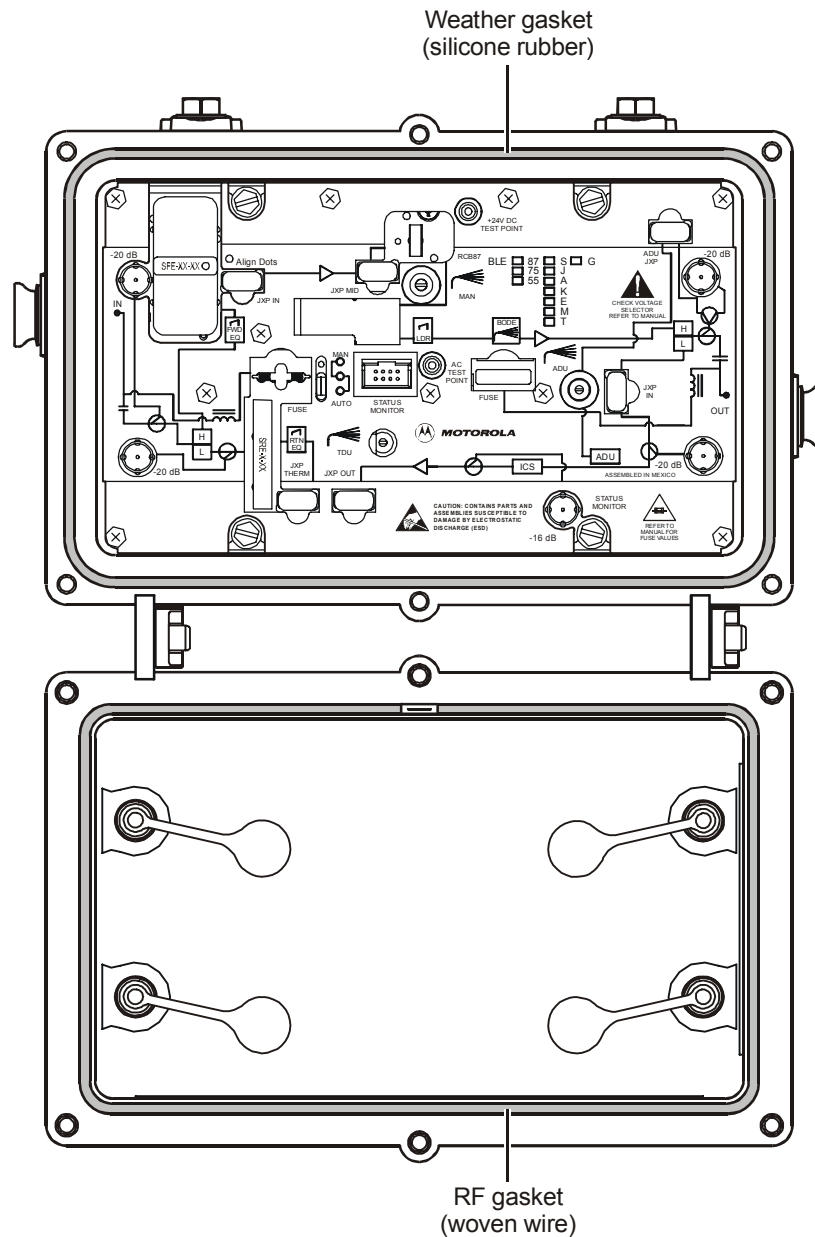

Port Locations

Two housing ports provide connection for coaxial cables. Four port plugs in the cover enable access to internal test points. All ports are protected by factory-inserted threaded plugs or plastic cap plugs. Discard the plastic cap plugs when you install the cable connectors.

Figure 2-5 illustrates the housing port locations:

Figure 2-5
Housing ports

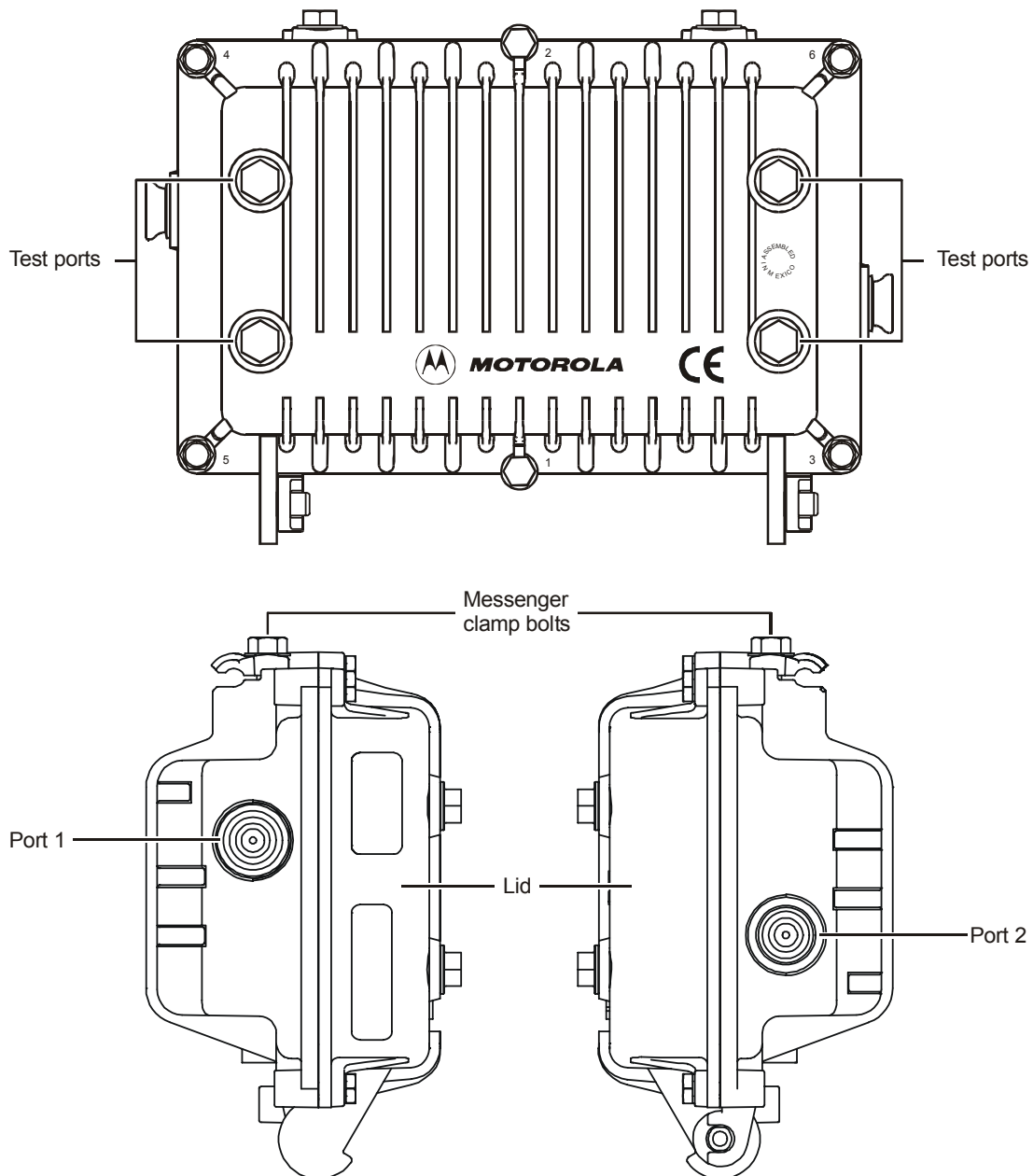

Power Supply

The BLE*/* power supply is a separate circuit board mounted to the underside of the amplifier module and is capable of 60 Vac or 90 Vac powering. The power supply provides a regulated 24 Vdc output over an ac input between 38 Vrms and 90 Vrms with a line frequency from 50 Hz through 60 Hz. Potentiometer R25 adjusts the output voltage to 24 Vdc, however, this is set at the factory and field adjustment is not recommended.

Figure 2-6 illustrates the components on the power supply:

Figure 2-6
BLE*/* power supply

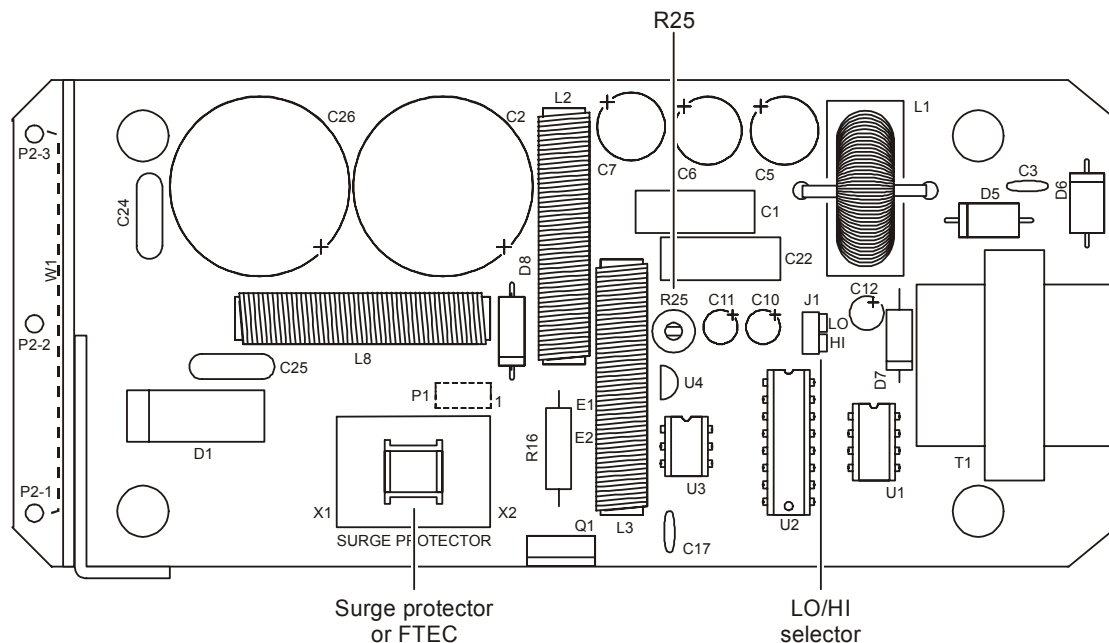

The power supply also contains a two-position LO/HI selector that sets the *start-up voltage* for 38 Vac or 55 Vac. The BLE*/* is shipped with the selector in the LO position which is the standard configuration. The selector should be switched to the HI position only for a 90 Vac system. This sets the start-up voltage at 55 Vac. Because this is only 5 V below 60 Vac, it is not practical in a 60 Vac system. There is no damage to the amplifier if the selector is not changed from the standard LO setting. However, changing the selector ensures that the dc supply does not turn on until the proper input voltage, 38 Vac or 55 Vac, is reached. This prevents excessive loading of the system power supply during turn-on after a system shutdown.

You must remove the power supply cover to access the selector illustrated in Figure 2-6. Section 3, “Amplifier Setup” explains changing the setting of this selector to meet system requirements.

The power supply includes a heavy-duty gas discharge tube that you can replace with the optional fast-transfer electronic-crowbar (FTEC) surge protector. The FTEC is a crowbar circuit that fires at approximately 245 V and presents a short circuit to the line during periods of overvoltage. After the ac input voltage returns to normal, the FTEC resumes its open state.

The factory-installed 20-ampere fuse, illustrated in Figure 2-8, provides power-passing to additional line extenders.

Forward Path

The operational gain of the E-GaAs BLE^{*/*} amplifiers is 28 dB or 32 dB (depending on model) with 16 dB of return loss. The operating gain includes provisions for the insertion loss of the input cable equalizer and required reserve gain to operate the Bode equalizer in the middle of its range. The low-noise figure, pre-amplifier stage, is a conventional 870 MHz hybrid followed by a power-doubled output stage. Between the two stages is a JXP-^{*}B pad socket, the Bode board, and the flatness and equalizer board. Because these losses are located interstage, the noise figure is only significantly impacted by the insertion loss of the forward cable equalizer or broadband cable simulator, and the input pad if its value is increased from zero.

Figure 2-7 illustrates the interconnection among these components:

Figure 2-7
BLE^{*/*} block diagram

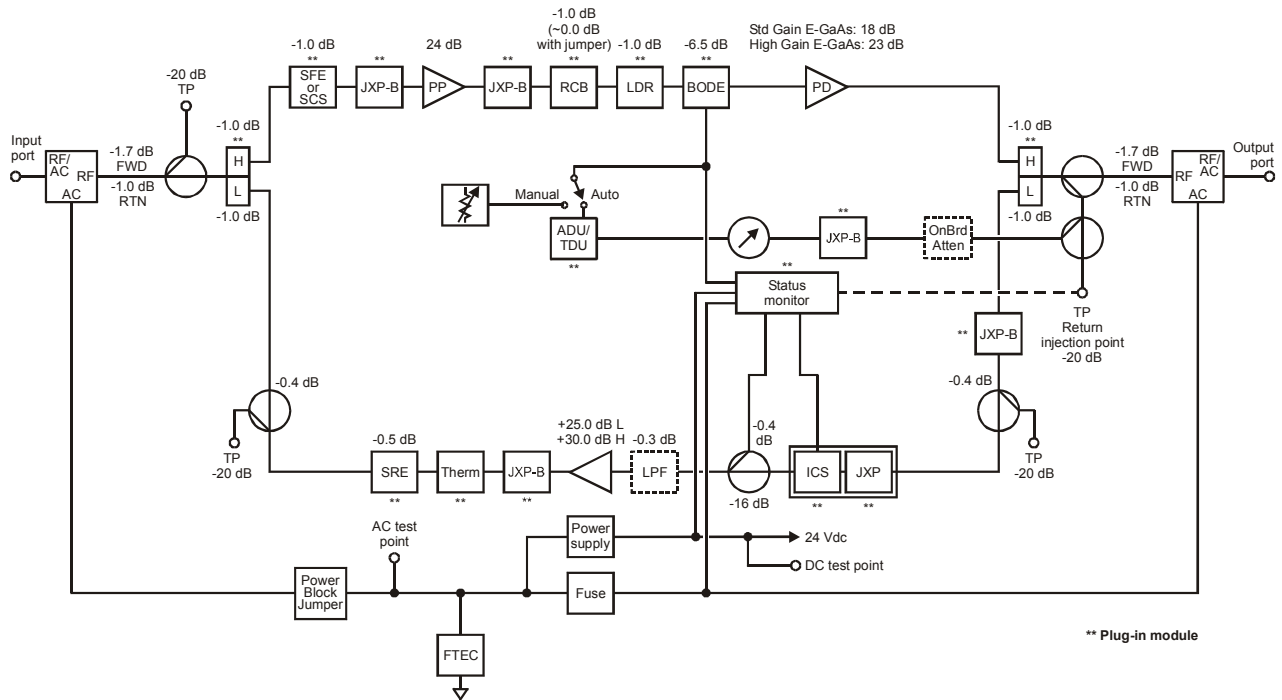

Return Path

The circuit board of the BLE^{*/*} accommodates the optional return path. The return path kit, model RA-Kit/H or RA-Kit/L, includes the return amplifier hybrid (illustrated in Figure 2-8) and jumpers. This equips the BLE^{*/*} to pass signals in the return or upstream direction. The standard circuit board contains all components including the diplex filters with extended return bandwidth for the amplifier input and output. All items are plug-in and easily installed.

Optional SRE-^{*}-^{*} return equalizers compensate for cable attenuation and are available in 1 dB increments for S-split, and 2 dB increments for all other splits, from 0 dB through 12 dB.

The input and output of the return path each include a JXP-*B pad facility. You can also use either pad socket as a test point or a signal injection point. The return output pad value is normally selected to control the return signal level into the next upstream amplifier. Select an appropriate return input pad to attenuate excessive input signal.

The return-input test point and the return-output test point are –20 dB directional couplers. Both test points present 75-ohm source impedance and do not require special test probes.

Ingress Control Switch

The ingress control switch (ICS) provides return-path signal attenuation or cutoff in the BLE*/*. This is accomplished through the frequency agile LIFELINE® status-monitoring module, LL-BLE-HMS-*/*. (Figure 2-8 illustrates the location of the optional ICS).

The ICS provides a means of isolating sources of ingress from a centralized location. Using a downstream command through the LIFELINE status-monitoring system, you can attenuate the return path through the line extender by 6 dB or by 38 dB. By reducing the ingress level at the headend or monitoring point, you can further isolate the ingress source.

After an ingress source is isolated to the last possible amplifier, node, or line extender, you can shut the return path off at that location. This limits the impact of the ingress on the remainder of the network while eliminating the source of ingress.

Options and Accessories

The factory ships the BLE*/* as a fully functional unit, but you must configure it appropriately for the field-location requirements. You must install the correct forward equalizer or broadband cable simulator and input pad to place the unit into service. Section 3, “Amplifier Setup” provides information to assist you in this task. Use model JXP-*B pads to control field signal levels. To compensate for temperature, install the automatic drive unit (ADU) or thermal drive unit (TDU) before placing the BLE*/* in service. You can install other items, such as a return amplifier and additional surge protection (model FTEC-BTA) at your discretion, but these options do not render the BLE*/* inoperative if they are not included.

Table 2-1 provides a comprehensive list of options and accessories for the BLE*/*:

Table 2-1
BLE*/* options and accessories

Model	Description	Function
ADU-*	Automatic Drive Unit	This board automatically controls amplifier output levels that change with cable attenuation and hybrid output. The selection of a pilot frequency is required.
TDU	Thermal Drive Unit	This board controls amplifier gain and slope for changes in cable attenuation for the sensed temperature.
RA-Kit/H or L	Return Amplifier Kit	This kit enables two-way operation and includes a high-or low-gain return hybrid and jumpers.
SFE-0, SFE-1	Starline Forward Equalizers	These equalizers are not bandwidth specific and compensate for 0 dB and 1 dB of cable, respectively, from 5 MHz to 1 GHz.

Model	Description	Function
SFE-*.*	Starline Forward Equalizer	This bandwidth specific (750 or 870 MHz) equalizer compensates for cable properties in 1 dB increments from 2 dB through 22 dB. The appropriate value must be installed. See the product catalog for additional information.
SRE-*.*	Starline Return Equalizer	This bandwidth specific equalizer compensates for cable attenuation in 1 dB increments from 0 dB through 12 dB for S-split (2 dB increments for all other splits). The appropriate value must be installed. See the product catalog for additional information.
SCS-*	Starline Cable Simulator	This simulator compensates for cable properties. The appropriate value must be installed. See the product catalog for additional information.
JXP-*B	Fixed attenuator	This pad attenuates excessive input signal. It is available in 1 dB increments from 0 dB through 26 dB. The appropriate value must be installed.
JXP-TH*C	Thermal attenuators	This option compensates for gain changes with temperature in the return path.
FTEC	Fast Transfer Electronic Crowbar	This option is used for overvoltage protection and replaces the existing surge protector.
LL-BLE-HMS-*/*	Status monitor module	This module enables monitoring of the unit's operating parameters by the LIFELINE status-monitoring system. This accessory also requires the deep housing cover.
BLE-LID/SM	Deep housing cover	This optional cover is required to contain the LIFELINE status monitor module.
RCB87	Response Correction Board	This optional board compensates for system roll-off at 870 MHz. The BLE*/* is shipped with a jumper in this location which you can replace when additional response correction is required.
JXP-RPC	Return Path Correction board	This optional board provides additional flatness response correction in the return path for systems that must meet especially stringent return path flatness requirements.
ICS-II	Ingress Control Switch	This option enables remote monitoring, isolation, and reduction of ingress on the return path by providing signal attenuation of 6 dB or cutoff of 38 dB typical. The unit is shipped with a jumper in this location.

Figure 2-8 illustrates the location of options and accessories in the BLE*/*:

Figure 2-8
BLE*/* options and accessories

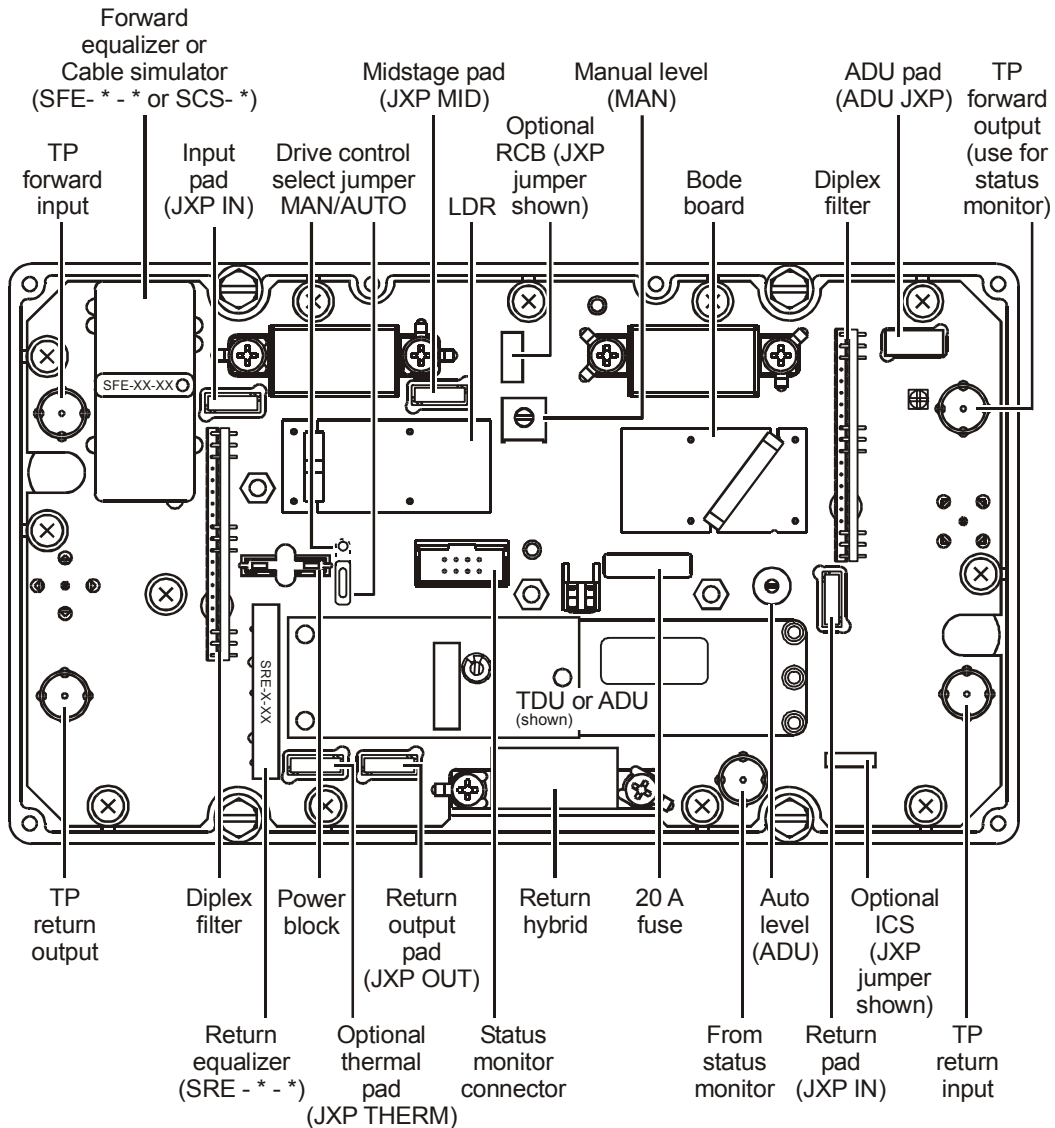

In the event of ADU or TDU board failure, you can select manual control of the Bode board. Figure 2-8 illustrates the location of the MAN/AUTO jumper on the main circuit board.

Section 3

Amplifier Setup

This section provides instructions for fully configuring the BLE*/* and describes the proper forward and return path alignment procedures. It is recommended that you read this entire section before you install the BLE*/*.

To successfully setup the BLE*/* you need to perform the following tasks:

- Forward path alignment
- Return path alignment
- Check powering and surge protection options

Forward Path Alignment

You must perform the following BLE*/* alignment procedures for proper performance in the forward path:

- Select the appropriate cable equalizer or cable simulator
- Select the appropriate input and midstage pads
- Verify proper flatness control
- Verify proper level control

Before You Begin

Before you begin to set-up the amplifier and perform forward-path alignment, please read the following instructions and recommendations.

For proper forward alignment obtain:

- RF output levels and tilts of all BLE*/*s in the forward or return path
- RF input level for the BLE*/* being set up (from system design or as-built map)
- A carrier at the system's highest frequency. It can be modulated or continuous wave (CW) and should be inserted in the headend at standard video levels. This carrier is used to simplify field set-up.

It is recommended that you:

- Install the system design value SFE-*. * and a high value (20 dB or above) input pad (JXP IN) before you install or remove the electronics chassis or apply power to the BLE*/*.

Leave the JXP IN pad location open if a high value pad is not available. A more accurate forward input test point reading is achieved with a high value pad installed.

- Do not use wire jumpers to bypass the SFE-*. * location.
- Recognize that actual pad and SFE-*. * values may differ slightly from their design values. This is caused by factors such as walkout errors, worst-case data utilization during design and temperature variation from 70°F.
- Secure the electronics chassis in the housing base and torque to 18-22 in-lbs. to facilitate heat transfer and avoid damage from overheating.

- Perform a bench alignment. Pre-aligning the BLE*/* response on the bench (Section 4, “Bench Testing”) for a system signature simplifies field alignment.
- Field-sweep the entire bandwidth of the amplifier to correct frequency response for passive signature and roll-off.
- Close the housing in accordance with the instructions in Section 5, “Installation.”

Cable Equalizer

Select the appropriate model SFE-*/* to compensate for cable attenuation versus frequency and to obtain the proper output tilt. The BLE*/* is equipped with the 8LDR*/III interstage equalizer and flatness board that compensates for cable attenuation. Any cable or passive slope beyond that of the LDR must be compensated for by selecting and installing the appropriate SFE-*/* cable equalizer.

Equalizers are available in 1 dB increments from 0 dB through 22 dB. The following examples describe how to choose the correct equalizer.

Example 1

The amplifier location includes 20 dB of cable (at 870 MHz) between its input and the preceding amplifier. Consider cable loss only. Exclude any flat loss due to splitters or other passive devices. The internal equalizer, model 8LDR/8/III, compensates for approximately 8 dB of cable. Subtract this cable length from the 20 dB of this example (20 – 8 = 12). The SFE-87-12 is the proper equalizer in this case. With this equalizer installed, the BLE*/* reproduces the output tilt of the last upstream amplifier.

When selecting an equalizer, choose the next lower value if the exact value is not available or in cases where the calculated value makes two choices possible.

Example 2

The BLE87*/* is used in a link following a fiber node with flat output. There is 16 dB of cable between the node and the line extender, plus passive losses that are assumed to be flat. Which is the proper equalizer to achieve the 10 dB of output tilt?

In this case, calculate the equalizer value by using the following method:

$$\text{SLOPE}_{\text{eq}} = \text{TILT}_{\text{out}} + \text{SIG}_{\text{lo}} - \text{SIG}_{\text{hi}} - \text{SLOPE}_{\text{ieq}}$$

where:

- SLOPE_{eq} = required SFE-87 slope
- TILT_{out} = required amplifier output tilt
- SIG_{lo} = signal input level at channel 2
- SIG_{hi} = signal input level at 870 MHz
- $\text{SLOPE}_{\text{ieq}}$ = interstage equalizer slope (8 dB)

From various references, such as manufacturer’s catalogs, you can determine that 16 dB of cable at the operating frequency of 870 MHz is 4 dB of loss at 54 MHz. This suggests that the channel 2 signal input level to the line extender is 12 dB greater (16 – 4 = 12) at channel 2 than it is at 870 MHz. Our example assumes that the high-end frequency level into the amplifier is +15 dBmV.

Substituting this information in equation (1) provides the following result:

$$10.0 \text{ dB} + 27 \text{ dB} - 15.0 \text{ dB} - 8.0 \text{ dB} = 14 \text{ dB}$$

The slope of the required equalizer is 14 dB. Table 3-1 and Figure 3-1 show that 14 dB of slope is caused by approximately 18 dB of cable at 870 MHz. Therefore the correct equalizer is model SFE-87-18.

When selecting an equalizer, choose the next lower value if the exact value is not available or in cases where the calculated value makes two choices possible.

Table 3-1 helps you choose the correct equalizers and also lists insertion loss at various frequencies:

Table 3-1
Starline Forward Equalizers – SFE**

Equalizer Value	Equalizer Slope	Frequency (MHz) versus Insertion Loss (dB)							
		50	200	300	450	550	650	750	870
SFE-75-									
22	16.3	17.3	11.6	9.1	6.0	4.2	2.5	1.0	
20	14.8	15.8	10.7	8.4	5.5	3.9	2.4	1.0	
18	13.4	14.4	9.7	7.6	5.1	3.6	2.2	1.0	
16	11.9	12.9	8.7	6.9	4.6	3.3	2.1	1.0	
14	10.4	11.4	7.8	6.1	4.2	3.0	2.0	1.0	
12	8.9	9.9	6.8	5.4	3.7	2.7	1.8	1.0	
10	7.4	8.4	5.8	4.7	3.3	2.4	1.7	1.0	
8	5.9	6.9	4.9	3.9	2.8	2.1	1.6	1.0	
6	4.5	5.5	3.9	3.2	2.4	1.9	1.4	1.0	
4	3.0	4.0	2.9	2.5	1.9	1.6	1.3	1.0	
2	1.5	2.5	2.0	1.7	1.5	1.3	1.1	1.0	
SFE-87-									
22	16.7	17.7	12.4	10.0	7.1	5.4	3.9	2.5	1.0
20	15.2	16.2	11.4	9.2	6.5	5.0	3.6	2.3	1.0
18	13.7	14.7	10.3	8.4	6.0	4.6	3.4	2.2	1.0
16	12.1	13.1	9.3	7.6	5.4	4.2	3.1	2.1	1.0
14	10.6	11.6	8.2	6.7	4.9	3.8	2.8	1.9	1.0
12	9.1	10.1	7.2	5.9	4.3	3.4	2.6	1.8	1.0
10	7.6	8.6	6.2	5.1	3.8	3.0	2.3	1.7	1.0
8	6.1	7.1	5.1	4.3	3.2	2.6	2.0	1.5	1.0
6	4.6	5.6	4.1	3.5	2.7	2.2	1.8	1.4	1.0
4	3.0	4.0	3.1	2.6	2.1	1.8	1.5	1.3	1.0
2	1.5	2.5	2.0	1.8	1.6	1.4	1.3	1.1	1.0

Figure 3-1 illustrates a graph of the equalizer slope versus equalizer value information presented in Table 3-1. The amount of cable equals the equalizer value.

Figure 3-1
Equalizer slope versus cable

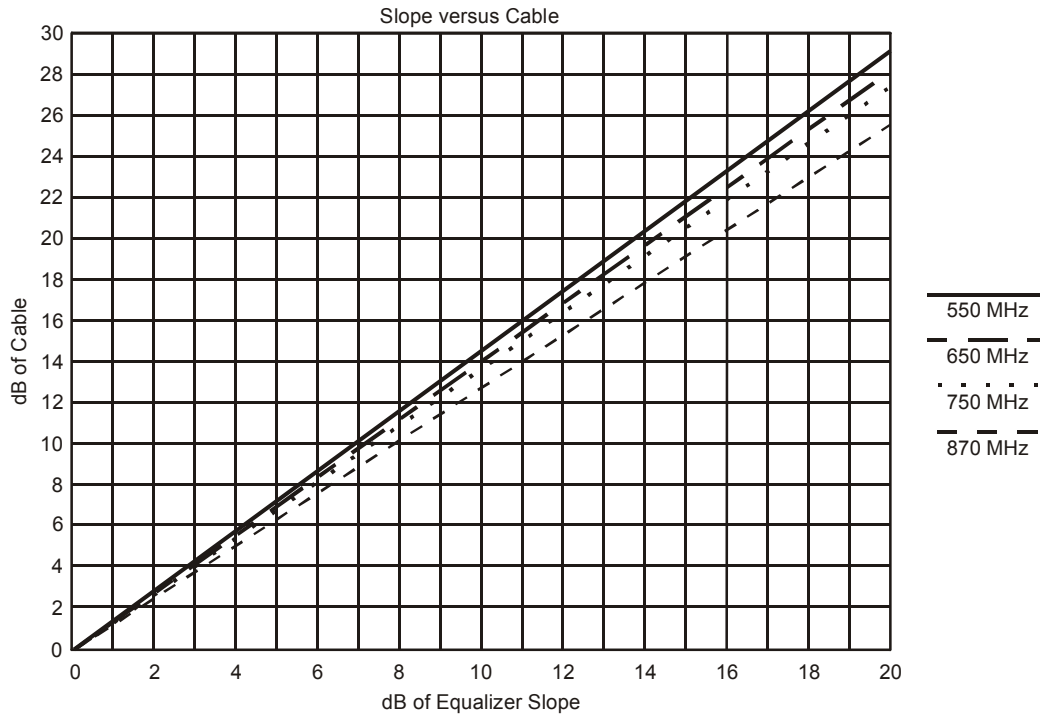

When selecting an equalizer, choose the next lower value if the exact value is not available or in cases where the calculated value makes two choices possible.

Because of errors in cable attenuation, slope in passive devices, and other independent variables, you may need to change the final value of the equalizer before you install the BLE*/*.

STARLINE Cable Simulators

STARLINE cable simulators, model SCS-*, are used in place of fixed equalizers in systems where: (1) the amplifiers are located close together, (2) there are large amounts of flat loss from passive components, or (3) it is necessary to compensate for reverse cable tilt. The simulators fit in the same location as the equalizers.

Table 3-2 and Figure 3-2 help you choose the correct simulators.

Table 3-2
STARLINE Cable Simulators

SCS-*	1	2	3	4	5	6	7	8	9	10
Frequency	Cable slope in dB									
40 MHz	0.0	0.1	0.1	0.1	0.2	0.2	0.3	0.3	0.3	0.4
45 MHz	0.0	0.0	0.1	0.1	0.1	0.1	0.1	0.1	0.2	0.2
50 MHz	0.0	0.0	0.0	0.0	0.0	0.0	0.0	0.0	0.0	0.0
72 MHz	-0.1	-0.2	-0.2	-0.3	-0.4	-0.4	-0.5	-0.6	-0.7	-0.7
108 MHz	-0.1	-0.3	-0.4	-0.5	-0.6	-0.8	-0.9	-1.0	-1.2	-1.3
150 MHz	-0.2	-0.5	-0.7	-0.9	-1.2	-1.4	-1.6	-1.9	-2.1	-2.3
211 MHz	-0.3	-0.7	-1.0	-1.4	-1.7	-2.1	-2.4	-2.8	-3.1	-3.5
250 MHz	-0.4	-0.8	-1.2	-1.7	-2.1	-2.5	-2.9	-3.3	-3.7	-4.1
300 MHz	-0.5	-1.0	-1.5	-1.9	-2.4	-2.9	-3.4	-3.9	-4.4	-4.9
350 MHz	-0.6	-1.1	-1.7	-2.2	-2.8	-3.3	-3.9	-4.4	-5.0	-5.5
400 MHz	-0.6	-1.2	-1.8	-2.5	-3.1	-3.7	-4.3	-4.9	-5.5	-6.2
450 MHz	-0.7	-1.4	-2.0	-2.7	-3.4	-4.1	-4.7	-5.4	-6.1	-6.8
550 MHz	-0.8	-1.6	-2.4	-3.2	-4.0	-4.8	-5.5	-6.3	-7.1	-7.9
750 MHz	-1.0	-2.0	-3.0	-4.0	-5.0	-6.0	-7.0	-8.0	-9.0	-10.0
870 MHz	-1.1	-2.2	-3.3	-4.4	-5.5	-6.7	-7.8	-8.9	-10.0	-11.1
50 MHz loss (typical)	-1.0	-1.0	-1.0	-1.0	-1.0	-1.0	-1.0	-1.0	-1.0	-1.0

The information in Table 3-2 is shown as a graph in Figure 3-2:

Figure 3-2
Frequency versus cable slope

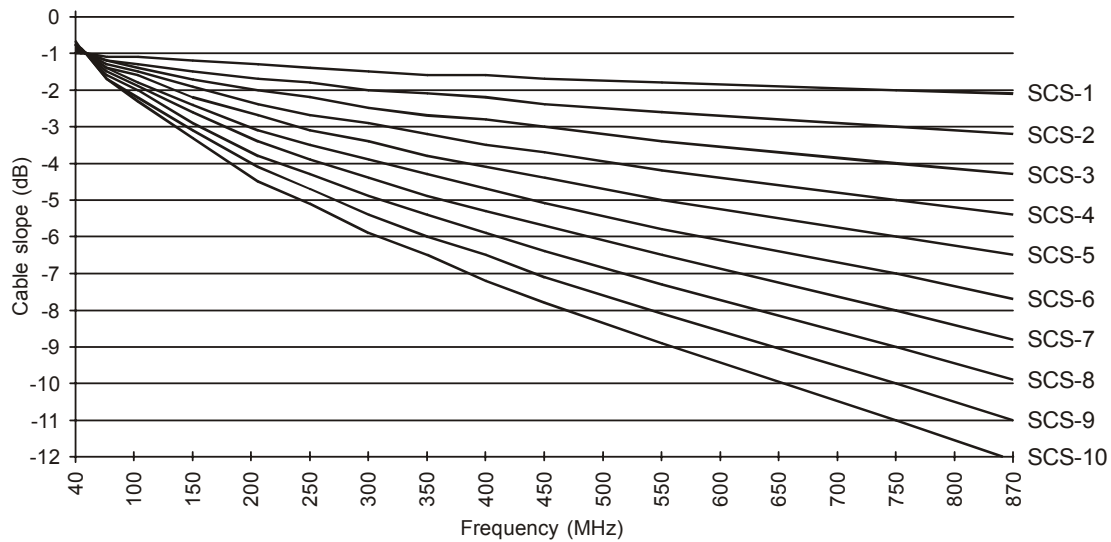

Input and Midstage Pads

Install Model JXP-*B pads to attenuate the signal per system design drawings. Generally, this consists of attenuating excessive input levels. You should pad the input to system levels for unity gain. Select and install the specified pad in the socket labeled JXP-IN on the chassis cover.

You can use the midstage pad (JXP-MID) to adjust the gain level and achieve the gain specification. Refer to Section 6, “Operating Tips,” for midstage padding information and recommendations.

Flatness Control

The 8LDR*/III circuit board includes flatness controls and a fixed cable equalizer for 870 MHz. This equalizer, plus the contribution of the hybrid gain stages, produces approximately the dB of slope indicated by the model number (8 dB of tilt with an 8LDR/8/III or 12 dB of tilt with an 8LDR/12/III).

You can adjust the LDR variable resistors and capacitors to flatten the response across the operating band (marker 1 to marker 4 as illustrated in Figure 3-4). Use C1, C2, R1, and R2 on the LDR board shown in Figure 3-3 for low-end flatness response (marker 1 to marker 2). The low-end flatness controls compensate for the roll-off caused by the diplex filters. Adjust C3 and R3 for a flat response across the mid-band (between marker 2 and 3). Adjust C7, C8, and R8 for a flat response across the band (marker 1 to marker 4). Adjust C6 for maximum gain at the high end (marker 3 to marker 4).

- C1 produces a peak that is centered just below the lowest forward frequency and varied in amplitude by R1.
- C2 produces a peak that is centered approximately 50 MHz above the lowest forward frequency and varied in amplitude by R2.

- C3 produces a peak that is centered approximately 300 MHz above the lowest forward frequency and varied in amplitude by R3. This adjustment provides more mid-band alignment flexibility.
- C6 adjusts for maximum gain at Fmax (870 MHz).
- C7 and R8 adjust for the flattest response in the mid- to upper-portion of the band.
- C8 adjusts for the flattest response in the low-to mid-range of the band.

L4, on the bottom of the LDR board, may slightly tune the upper portion of the response. *Excessive spreading of L4 will cause insertion loss to increase.*

Figure 3-3
8LDR*/III component layout (top-left, bottom-right)

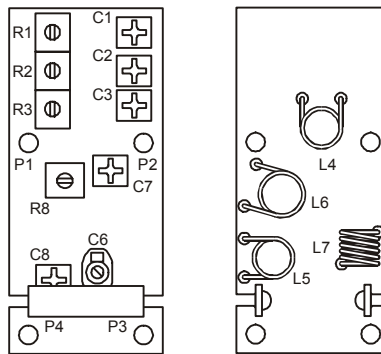
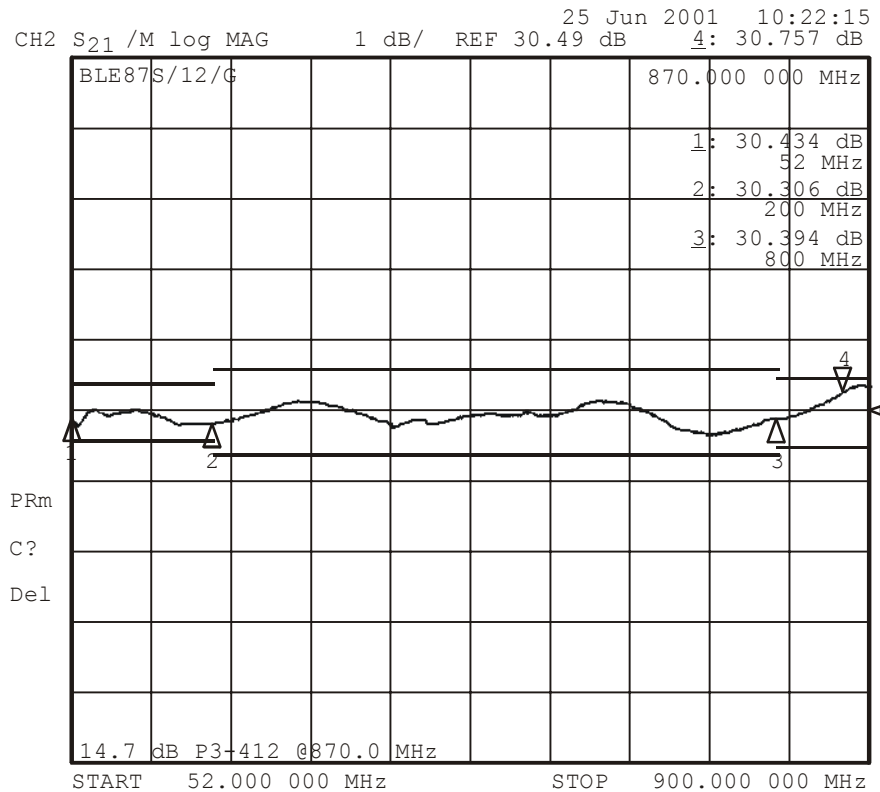

Figure 3-4 illustrates BLE87* flatness and control ranges:

Figure 3-4
Typical flatness and control ranges



Directional Coupler Test Points

Accurate -20 dB directional-coupler test points are available at the input and at the output of the BLE*/*. Because these test points are 75 -ohm source impedance, they do not require special test probes.

After the output hybrid, a second directional coupler provides signal to the optional ADU board. This signal is used only when the ADU board is installed. It is not necessary to terminate this port when the ADU is not installed.

Bode Equalization

The Bode board, which is an electronically controlled equalizer, receives its control input from either the ADU or TDU control boards. The response of the Bode board compensates for cable attenuation changes due to temperature. If necessary, you can control the Bode board manually using the potentiometer labeled Manual Level (MAN) in Figure 2-8.

Amplifier Level Control

Signal levels vary in a cable system primarily because cable attenuation changes with temperature. Other components such as passives and amplifier hybrids are also affected by temperature changes. To automatically compensate for these signal level fluctuations and control output level, you must select the optional ADU or TDU. For improved output level stability, use of the ADU or TDU is recommended.

When necessary and appropriate, you can also use manual gain control. The BLE^{*/*} gain is then determined by the potentiometer marked MAN on the electronics chassis cover.

Manual Gain Control

To use manual gain control:

- 1 Verify that the electronics chassis is installed correctly.
- 2 Ensure that there is continuity in the forward path by installing the design-value input equalizer and design value input JXP-^{*}B attenuator.
- 3 Ensure that the drive control select jumper is in the MAN position.
- 4 Use a signal-level meter to measure the high band-edge carrier input level at the input test point: 750 MHz = channel 116, 870 MHz = channel 136.

This carrier should be at standard analog level, non-scrambled.

- 5 Verify that the input level agrees with the design specification input.

If the level is different from design, adjust accordingly. For example: the design level is 19 dBmV at the highest frequency and the design pad value is JXP-3B. If the actual measured level is 21 dBmV, then you must change the pad to a JXP-5B.

If the actual levels are significantly different from the design levels, it is recommended that you investigate or consult system management before proceeding.

- 6 Connect the signal-level meter to the output test point and tune the meter to the high-end channel.
- 7 Turn the manual gain reserve (MAN) control (illustrated in Figure 2-8) to maximum (fully clockwise) and then reduce the output as noted in Table 3-3 below:

Table 3-3
Gain reserve versus ambient temperature

Temperature	Gain Reserve
Above 110°F (43°C)	3 dB
32°F (0°C) to 110°F (43°C)	4 dB
Below 32°F (0°C)	5 dB

- 8 Check the amplifier output tilt by measuring the high band- and low band-edge carriers.
 - High = channel 116 (745.25 MHz) or channel 136 (865.25 MHz)
 - Low = channel 2 (55.25 MHz) or channel 3 (61.25 MHz)
 - If the tilt is less than required, install a higher value input equalizer.
 - If the tilt is greater than required, install a lower value input equalizer.
 - If the high value equalizer provides too much tilt and the low value equalizer provides too little tilt, use the lower value equalizer. Under-equalization is preferred to over-equalization.

If you use an SCS cable simulator and the design value is changed, you must also adjust the input pad. For each 1 dB increase in SCS value, 1 dB of loss is introduced at 750 MHz or 1.1 dB of loss at 870 MHz. Therefore, to maintain a proper gain level, it is necessary to adjust the input pad value as follows:

- For each increase in SCS value, decrease the input pad by 1 dB.
 - For each decrease in SCS value, increase the input pad by 1 dB.
 - If you replace an SFE with an SCS, reduce the value of the input pad by the value of the SCS.
- 9 Measure the output level at the highest frequency.

It should be within 1 dB of the system design level. If it is not, you must adjust the mid-stage pad (JXP MID) accordingly. Refer to Section 6, "Operating Tips," for mid-stage padding information and recommendations.

Thermal Drive Unit

The TDU senses temperature and controls the Bode board. It is assumed that the cable is subjected to the same or similar temperature; therefore, you should not use the TDU for underground installations.

To set-up the TDU:

- 1 Place the jumper on the TDU (Figure 3-5) to the LOW, MEDIUM, or HIGH position to specify the amount of cable for which the TDU compensates at the highest frequency preceding the BLE*/* station. Low = 0 dB to 15 dB of cable, medium = 15 dB to 30 dB, and high = 30 dB or more of cable.

Figure 3-5
TDU cable selector

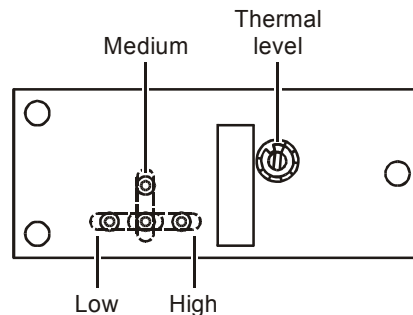

- 2 Position the drive control select jumper (Figure 2-8) temporarily in the MAN position and perform the complete procedure described in Manual Gain Control if not already completed.
- 3 Position the drive control select jumper to AUTO.
- 4 Connect a signal-level meter to the FWD OUT test point and tune the meter to the high band-edge carrier.
- 5 Turn the thermal level potentiometer on the TDU fully clockwise and then reduce to obtain the level obtained in Step 9 under Manual Gain Control.

Automatic Drive Unit

The ADU operates by using surface acoustic wave (SAW) filters to select a pilot frequency and then monitors the amplitude of this frequency. Any change in signal level is fed back to the Bode equalizer. It is assumed that the encountered signal level changes are due to changes in cable attenuation and hybrid output associated with a change in temperature. The Bode equalizer then changes its insertion loss to maintain a constant output level. The ADU (illustrated in Figure 3-6) maintains the most precise output level of the three available methods.

Figure 3-6
ADU

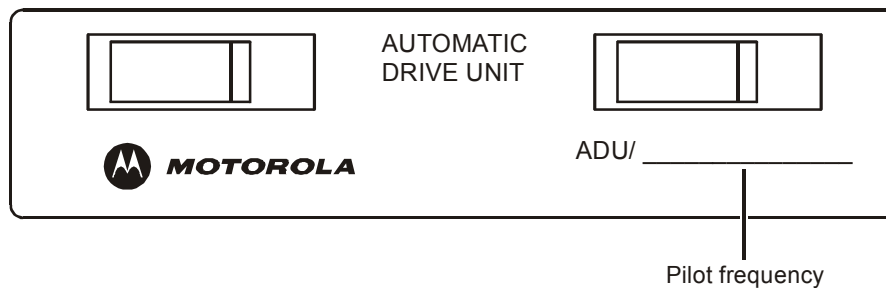

To set-up the ADU:

- 1 Position the drive control select jumper temporarily to the MAN position and perform the complete procedure described in Manual Gain Control if not already completed.
- 2 Verify that the frequency stamped on the ADU control unit is the same as the system pilot frequency. The pilot frequency is a CW or an available NTSC television channel not scrambled using sync suppression and not a digital channel.
- 3 Position the drive control select jumper to AUTO.
- 4 Connect a signal-level meter to the FWD OUT test point and tune the meter to the high band-edge carrier.
- 5 Turn the auto level control potentiometer (ADU) (illustrated in Figure 2-8) fully clockwise and then reduce to obtain the level obtained in Step 9 under Manual Gain Control.

ADU Pads and Levels

This subsection provides information regarding the proper ADU padding requirements for the BLE*/*.

A JXP-*B pad is installed in the input line to the ADU location. This pad adjusts the ADU input level for the standard application of the BLE*/*. You can change this pad depending on the operational output of the BLE*/*.

In general, a JXP-6B pad is recommended in the BLE*/* ADU circuit or a JXP-0B for the QAM ADU. These are the standard ADU pad values as shipped from the factory and are appropriate for an amplifier output level range from +43 dBmV to +49 dBmV at 550 MHz. For the QAM ADU, the 0 dB pad works up to +47 dBmV at 550 MHz.

To determine the correct ADU pad value for other output levels, refer to Table 3-4:

Table 3-4
BLE*/* AGC pad levels

Option	Pad Value (below +43 dBmV)	Pad Value (above +47 dBmV)	Pad Value (above +49 dBmV)
ADU	0 dB	N/A	10 dB
QADU	0 dB	6 dB	N/A

The use of the ADU or TDU is recommended for improved output level stability although you can operate the BLE*/* in the manual mode. Select manual mode by placing the drive control select jumper, illustrated in Figure 2-8, in the MAN position. The gain of the BLE*/* is then determined by the potentiometer marked MAN on the amplifier cover.

Return Path Alignment

The following subsections describe the BLE*/* alignment procedures required for proper performance in the return path.

Before You Begin

Before you begin to set-up the amplifier and perform return-path alignment, please read the following instructions and recommendations.

For proper return alignment obtain:

- RF alignment levels and insertion points for all BLE*/*s
- RF reference output level of the headend optical receivers

Equipment required for return-path alignment includes:

- Full complement of JXP-*B pads and Starline Return Equalizers (SRE-*-*)
- Reverse signal generator — must produce at least one signal within the return bandpass and have variable output
- Return sweep or alignment equipment

It is recommended that you:

- Do not use wire jumpers to bypass the SRE-**-* location
- Perform the return optical link set up before performing amplifier set up
- Specify reverse alignment design levels for a single carrier
- Consider sweep equipment as a single carrier and operate at design levels
- Do not include injection point losses in reverse design levels

If JXP THERM devices (JXP-TH*C) are specified for level control, they should be installed in the JXP THERM pad facility (illustrated in Figure 2-8).

Alignment Procedure

The return amplifier configuration includes one low-gain (25 dB) or one high-gain (30 dB) return amplifier hybrid, and an appropriate SRE-**-* equalizer. All components are plug-in and are easily installed.

To align the return path:

- 1 If the BLE** is powered, remove all fuses before you perform the following steps.
- 2 If necessary, carefully install a reverse hybrid amplifier.
- 3 Ensure that both hybrid screws are tight. Torque the screws to 10 to 12 in-lbs. Over torque can damage the hybrid.
- 4 Install the design value pad in the return output pad location (JXP OUT).
- 5 Install the design value return equalizer, SRE-**-*, in the RTN EQ location.
- 6 Verify that the return input pad location (JXP-IN) has a 0 dB pad (or JXP-ZX jumper) installed.
- 7 If you ordered the optional ICS, verify that the switch is installed in the ICS location. If it was not ordered, the factory-installed jumper should remain in the ICS location.
- 8 Verify that the return output pad socket (JXP THERM), located between the hybrid output and the SRE-**-*, has a 0 dB pad (or JXP-ZX jumper) or a JXP-TH*C installed.
- 9 Set the sweep equipment output level to the amplifier's design input level. Add insertion point loss.
- 10 If required, change the return output pad (JXP OUT) and/or return equalizer to achieve, as close as possible, a match of the reference level as compared to the node.
- 11 Verify the sweep response of all insertion points if applicable.
- 12 Verify that the pad and equalizer values are similar to the map design values.

You can verify proper return alignment by injecting a carrier, at the design level, into any amplifier at random. Proper alignment is achieved if you observe the reference level at the headend optical receiver output.

Return levels used for alignment are not necessarily operational system levels. These levels vary from system to system due to differences in equipment, architectures and design philosophies. For an in-depth analysis and discussion of the return path, refer to Motorola reference guide *Return Path Level Selection, Setup and Alignment Procedure*.

Powering and Surge Protection

In conventional applications, the BLE*/**s are powered through the input port.

CAUTION!



To avoid damage to the hybrids, it is recommended that you remove the input pad (JXP-IN) before you apply power to the BLE*/**.

A 20-ampere, blade-type fuse is furnished in the amplifier module and provides overcurrent protection for ac power applied to the input. You can power the BLE*/** from the output without passing power through to the input port. To block power from the input port, remove the power-block jumper illustrated in Figure 2-8.

WARNING!



To avoid possible injury to personnel or damage to the equipment, remove 60/90 volt ac power from the system before you remove any components from the housing.

The BLE*/** is shipped from the factory configured for 38 through 90 Vac powering as described in Section 2, "Overview". To configure the BLE*/** for 55 Vac through 90 Vac operation:

- 1 Remove the electronics chassis from the housing.
- 2 Remove the power-supply cover.
- 3 Move the LO/HI selector (jumper J1 on the power-supply board) from the LO to HI position. Figure 2-6 illustrates the jumper location.
- 4 Re-install the power-supply cover and torque the screws to 10 to 12 in-lbs.
- 5 Re-install the electronics chassis in the housing and torque the hold-down bolts to 18 to 22 in-lbs.

Standard surge protection is provided in the power supply by a heavy-duty, 230-volt, gas discharge surge protector. As an option, you can replace the gas discharge tube with the FTEC overvoltage protector. The FTEC has a firing potential of approximately 245 volts.

To install the FTEC:

- 1 Remove the electronics chassis from the housing.
- 2 Remove the power-supply cover.
- 3 Remove the gas-tube surge protector, illustrated in Figure 2-6.
- 4 Replace it with the FTEC.
- 5 Re-install the power-supply cover and torque the screws to 10 to 12 in-lbs.
- 6 Re-install the electronics chassis in the housing and torque the hold-down bolts to 18 to 22 in-lbs.

Section 4

Bench Testing

Motorola's recommended procedure for placing a new BLE** into service is to fully test it on the bench before it is field installed. There are specific alignment procedures that ensure proper functioning of all components and simplify final installation. If the BLE** is properly aligned on the bench only minor adjustments may be required in the field.

The following subsections provide instructions to bench align the BLE**.

Before You Begin

The BLE** is shipped with a 20 ampere blade-type fuse in the output port for over current protection.

CAUTION!



To avoid applying 60/90 Vac to the test equipment during testing, remove the fuse illustrated in Figure 2-8.

Open the housing and remove the chassis cover. Refer to your system drawings or records to confirm the presence of the required options as described in Section 2, "Overview," Options and Accessories.

Test Equipment and Connections

The equipment typically used for testing the BLE^{*/*} consists of a network analyzer such as the HP 8712 or 8713 series, a 60/90 Vac bench power supply, a cable simulator, a Motorola model SSP-PIN power combiner, and a variety of jumper cables, adapters, and fittings.

CAUTION!



To protect the network analyzer and sweep comparator, you must configure the SSP-PIN power combiner to block ac power from the input port.

Fabricate a cable simulator that you can configure to provide the desired cable loss in 1 dB increments up to approximately 30 dB. Then, connect the test equipment as shown in Figure 4-1:

Figure 4-1

Test equipment connections for bench sweeping

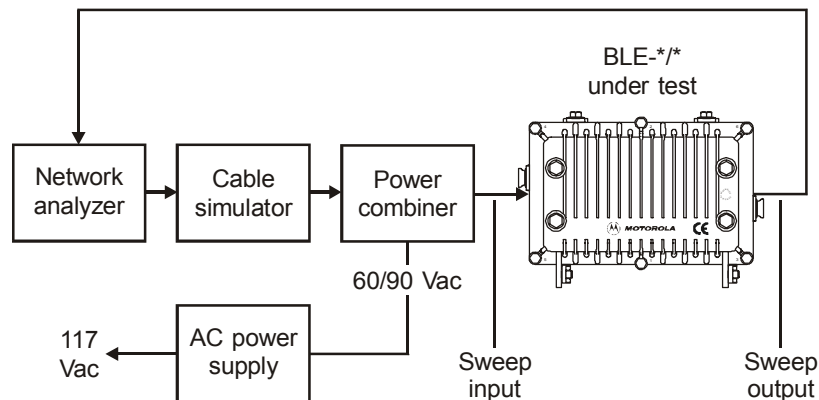

CAUTION!



Before you begin the following subsection, remove the input pad, JXP-IN, to avoid damage to the hybrids before you apply power.

Measuring Forward Gain

This subsection provides instructions for measuring the full gain and the operational gain and flatness of the BLE^{*/*}.

To measure the full gain of the amplifier:

- 1 Determine whether the power-supply jumper (J1) is positioned for LO or HI operation.
- 2 Connect the BLE^{*/*} to the test equipment as illustrated in Figure 4-1 and apply power.
- 3 Verify that the dc voltage is $24\text{ V} \pm 0.4\text{ V}$ and re-install the input pad.
- 4 Apply the sweep signal and adjust test equipment as needed.
- 5 Select manual gain by placing the drive control select jumper in the MAN position and turn the MANUAL LEVEL control (Figure 2-8) fully clockwise.

- 6 Measure the gain at mixed forward frequency using the procedure outlined in the operator manual provided with the test equipment in use.

To correct this number, add the insertion loss of the SSP-PIN power combiner (0.5 dB at 550 MHz, 0.6 dB at 750 MHz, or 0.7 dB at 870 MHz), the loss of the cable simulator at mixed forward frequency, and the loss of the cable equalizer (1.0 dB), if it is installed.

Example:

The test equipment indicates a measured gain of 14.5 dB with a BLE87S/* and the cable simulator is set to 20 dB.

+0.7 dB (power combiner)
 +1.0 dB (cable equalizer)
 +20.0 dB (cable simulator)
 +14.5 dB (measured gain)
 +36.2 dB (unit gain)

The result must meet advertised specifications for the unit.

The operational gain of the BLE*/* provides reduced gain capability. This enables the unit to operate in the proper region of the Bode board when it is controlled by the ADU or TDU drive units.

To measure the operational gain and flatness of the amplifier:

- 1 Perform steps 1 through 6 in Measuring Forward Gain above.
- 2 Estimate the ambient temperature and find the required gain reserve by referring to Table 3-3. Reduce the gain at the highest frequency by the amount given in the table.

Example:

The ambient temperature is 70°F. The table indicates that the required gain reserve is 4 dB. Reduce the gain by 4 dB.

The operational gain is the sum of the measured gain after performing Step 2, plus all losses, such as power combiner, cable loss, equalizer, and cable simulator.

The sweep response is essentially flat at this point. If the response exhibits tilt, the cable equalizer must be changed. Install a higher equalizer value if the gain is greater at the low frequencies; install the next lower equalizer value if the gain is less at the low-end frequencies.

- 3 Measure the gain excursions from an average value within the bandpass.

The result is the peak-to-valley (P-V) flatness. Some improvement is possible by adjusting the flatness controls on the *LDR*/III board as described in Section 3, "Amplifier Setup," Flatness Control. Figure 3-3 illustrates the location of these controls on the *LDR*/III board.

Testing Return Gain and Response

After configuring the return path, you can test the return bandpass to ensure compliance with specifications. When testing the return amplifier, remember that it is a flat amplifier. Therefore, the cable simulator must remain in the test set-up and must remain set to the same cable equivalent as in the forward sweep test. This provides an approximate indication of the frequency response, which you can achieve in the field.

To test for return gain and response:

- 1 Reconnect the test equipment and switch the *sweep input* and *sweep output* leads of the BLE*/* under test to be opposite of the connection shown in Figure 4-1.
- 2 Remove the power block at the input port and replace the 20 A fuse at the output port (both illustrated in Figure 2-8) before you apply power.
- 3 Re-adjust the test equipment to sweep from 4 MHz through the maximum return band frequency plus 10 MHz.

The expected response is flat. Any tilt, which is due to the return equalizer, must average out to a flat response in a cascade of amplifiers. A slope adjustment is not available in the return bandpass.

- 4 Measure the gain at the maximum return band frequency (40 MHz for S-split).

The amplifier gain is the sum of: the measured gain, the insertion loss of the return cable equalizer at the maximum return band frequency, the insertion loss of the power combiner, any pads installed in either the input or output pad locations, plus the cable simulator loss at the maximum return band frequency. The measured gain must meet advertised specifications for the return amplifier.

Example:

14.0 dB (measured gain)
+ 1.0 dB (equalizer insertion loss)
+ 0.7 dB (power combiner)
+ 0.0 dB (pads)
+ 4.6 dB (cable simulator at 40 MHz)
+20.3 dB (unit gain)

Completing the Test Procedures

The amplifier is now approximately tailored for a specific field location. Additional adjustments after installation are minor in nature. Re-install the fuse or power-block removed during testing.

Complete station records by recording pertinent information. Remove test-equipment connections and close the housing following instructions provided in Section 5, "Installation," Closing the Housing.

Section 5

Installation

The field installation procedures presented in the following subsections assume that the amplifier was previously tested and bench aligned. Cable power and RF signal must be available on the system. Although it is desirable to have a full complement of channels available for balancing, you can adjust the BLE**/* adequately with a limited number of channels.

You can install the BLE-HSG/15 on a messenger strand (aerial) or on a pedestal. The following subsections provide details on each application.

Aerial Installation

The housing is normally mounted without the electronics chassis to avoid possible damage during installation. Connections are made using standard pin-type connectors with a nominal center-conductor diameter of 0.067 inches. The minimum length of the center-conductor pin is 1.5 inches and the maximum length is 1.65 inches. Longer pins can extend past the center-conductor seizure mechanism and degrade the match. Extremely long pins can result in a short circuit.

Figure 5-1
Center-conductor pin length

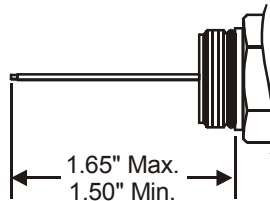

To install the unit:

- 1 Power down the cable before you install the housing. This avoids blown fuses, tripped circuit breakers, and possible personal injury.
- 2 Mount the housing, and torque the two 5/16-inch messenger clamp bolts (illustrated in Figure 2-5) to 10 to 12 ft-lbs.
- 3 Form the customary expansion loops and make all cable connections according to system design.
- 4 Tighten the center-conductor seizure screw using a Phillips-head screwdriver. An alternate method is to use a 3/16-inch socket and a torque wrench. The recommended torque is 12 in-lbs. maximum.
- 5 To avoid water ingress, ensure that aluminum connectors are torqued to the specifications recommended by the connector manufacturer.
- 6 If previously removed, re-install the electronics chassis and fasten it to the housing with the four captive bolts. Torque to 18 to 22 in-lbs.
- 7 *Remove the input pad (JXP-IN) to avoid damage to the hybrids.*
- 8 Apply power to the unit and allocate a few minutes for warm up.

- 9 Check the ac voltage setting (jumper J1, Figure 2-6).

J1 position	Description
LO	The voltage must be greater than 38 Vac as read with a true rms voltmeter or 42 Vac when using a conventional, average reading, ac voltmeter.
HI	The voltage must be greater than 55 Vac when read with a true rms voltmeter or 61 Vac when using a conventional, average reading, ac voltmeter.

- 10 Check the dc voltage. Verify that it is between 23.6 V and 24.4 V and re-install the input pad.
- 11 If necessary, rebalance the amplifier following the instructions in Section 3, "Amplifier Setup."
- 12 Check the tightness of the electronics chassis cover screws (10 to 12 in-lbs.) and electronics chassis hold-down bolts (18 to 22 in-lbs.).
- 13 Check the condition of the RF and weather gaskets and replace them if necessary. If needed, also apply a light coating of silicone grease.
- 14 Close the housing and use a torque wrench to sequentially and progressively tighten the housing bolts to a final torque of 6 ft-lb in the sequence specified on the housing cover and illustrated in Figure 5-2.

Figure 5-2
Torque sequence

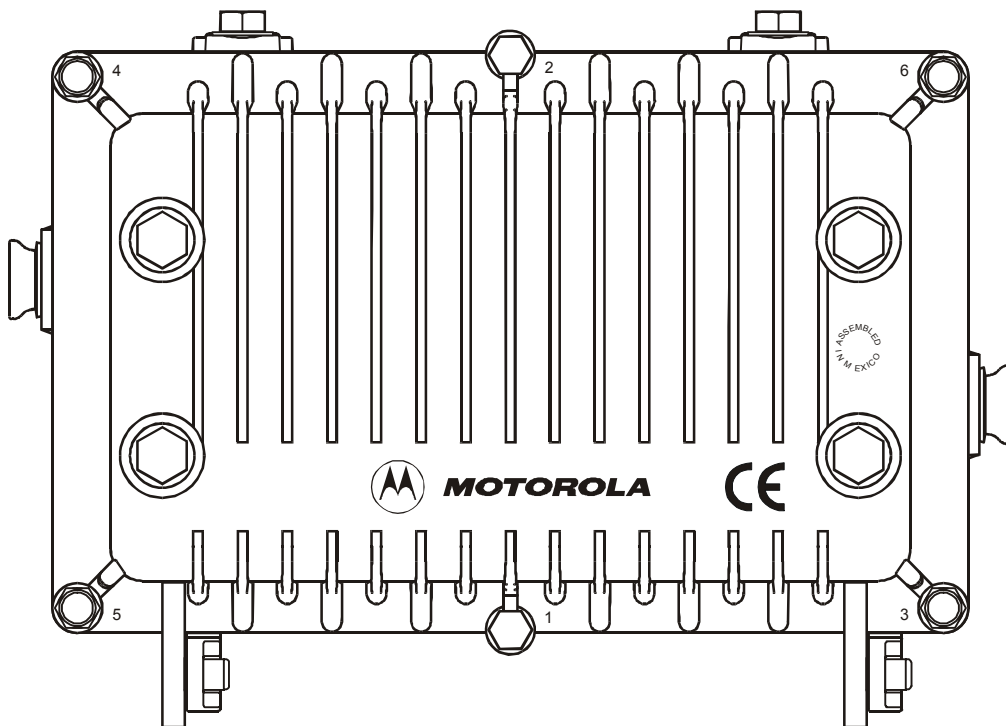

Pedestal Installation

Pedestal installation is similar to aerial installation with the exception of temperature and mounting procedure. In an aerial installation, the cable and amplifier are subject to the same temperature. In contrast, pedestal installation provides a stable temperature environment for the buried cable while subjecting the elevated amplifier to higher temperatures. The ADU, if installed, functions the same as in an aerial installation, and does not require further attention. See Section 3, "Amplifier Setup," Amplifier Level Control for additional information.

Manual thermal compensation provided by the TDU can be inaccurate and result in signal level changes with ambient temperature change. One approach to this problem is to select the least amount of cable setting (low) on the TDU. This results in minimal gain change with temperature. A preferred approach is to install a JXP-TH°C thermal attenuator while operating the BLE*/* in the manual mode.

To mount the BLE*/* on a pedestal:

- 1 Remove the two 5/16-inch messenger clamps and bolts located on the long side of the housing.
- 2 Locate the two 5/16-inch holes 4.0 inches center-to-center cast into the housing base.
- 3 Use the two 5/16-inch bolts to install the BLE*/* to the pre-drilled pedestal mounting plate and torque to 10 to 12 ft-lbs.

Operating Tips

This section describes using amplifiers in lower frequency systems and in lower gain systems.

Using Amplifiers in Lower Frequency Systems

When using the BLE*/* in 750 MHz or 550 MHz systems, you must consider the best method for handling the reduced bandwidth and channel-loading requirement. The following information helps you determine the best approach.

For distribution systems designed and installed as 870 MHz systems, but carrying a reduced channel load, there are no further concerns. You can add or remove channels at your discretion. If the system operates with ADUs, the pilot channel cannot be disturbed. Reduced channel loading improves distortion.

For lower-frequency systems, such as 750 MHz or 550 MHz, you will need to take into account the reduced gain from 870 MHz. Due to the amplifier tilt, there will be some loss in gain from the published operational specification at 870 MHz. For example, a 32 dB 870 MHz BLE with 12 dB of tilt will lose approximately 1.5 dB of gain to 750 MHz, resulting in approximately 30.5 dB of gain at 750 MHz. If tilt needs to be adjusted, you may accommodate by changing the forward equalizer (SFE) value. Also, to avoid any additional loss in gain, it is optimal to use the equalizers that match the system frequency. For a 750 MHz system, the SFE-75-*s are the best choice, even in an 870 MHz amplifier. Note also, that the equalizer cuts off at the frequency value for which it is designed. For example, an SFE-75-* cuts off frequencies above 750 MHz. Therefore, if you have an 870 MHz system and need the equalizer to perform to 870 MHz, you must use an SFE-87-*.

Using Amplifiers in Lower Gain Systems

There are two pad facilities in the forward path: (1) the pad location (JXP-IN) at the input to the amplifier, and (2) the midstage pad (JXP-MID) located between the pre-amplifier and the output hybrid.

The input pad (JXP-IN) is normally changed to accommodate excessive input levels. When operating at the same output levels, a BLE*/* with an input pad has the same carrier-to-noise (c/n) and distortion performance as a BLE*/* without the input pad. Because it only attenuates excess signal, it has no effect on the overall performance of the BLE*/*.

If necessary, to achieve the gain specification, you can use the midstage pad (JXP-MID) to reduce the gain of the BLE*/*. However, this will affect amplifier performance. Midstage padding has minimal impact on the noise figure, therefore, carrier-to-noise performance is maintained. When operating at the same output levels, the midstage pad forces the pre-amplifier to operate at a higher output level, thereby degrading station distortion performance. Due to the superior distortion performance provided by the latest E-GaAs BLEs, this should not be a major concern assuming the pad value is reasonable.

It is recommended that you contact Motorola's TRC or your account representative for specific information regarding use of the midstage pads.

Appendix A

Specifications

Specifications are valid over the given passband and operating temperature range of -40°F to $+140^{\circ}\text{F}$ (-40°C to $+60^{\circ}\text{C}$). Specifications stated are typical unless otherwise noted, and are subject to change. Refer to the Motorola BCS web site or contact your account representative for the latest specifications.

Model BLE87S/H*

Specification	Forward Amplifier
Passband (S-split)	52 through 870 MHz
Gain	
Full	36 dB (with SFE-**-*)
Operational	32 dB (with SFE-**-* and slope reserves)
Flatness	
52 through 870 MHz	± 0.70 dB maximum
Level control, automatic	Bode board using ADU/TDU
Gain control	Fixed pads, JXP-**B
Performance - reference frequency (MHz)	870/550/52
at typical output (dBmV)	43/44/37
Channels	79 analog/320 MHz digital (suppressed by 6 dB)
Crossmod (worst case)	-63 dB
CTB (worst case)	-74 dB
CSO (worst case)	-74 dB
Noise figure	
at 52 MHz	9 dB (with SFE-1) maximum
at 870 MHz	10 dB (with SFE-1) maximum
Interstage equalizer, 8LDR/8/H/III	8 ± 1 dB
Hum modulation	-65 dB
Return loss, input/output	16 dB minimum at operational level
Test points, input/output	20 ± 0.7 dB
Housing dimensions	10.6 L \times 8.0 W \times 4.7 D inches (26.9 \times 20.3 \times 11.9 cm)
Weight	7.2 pounds (3.2 kg)

Model BLE87S/G*

Specification	Forward Amplifier
Passband (S-split)	52 through 870 MHz
Gain	
Full	32 dB (with SFE-*-*)
Operational	28 dB (with SFE-*-* and slope reserves)
Flatness	
52 through 870 MHz	±0.70 dB maximum
Level control, automatic	Bode board using ADU/TDU
Gain control	Fixed pads, JXP-*B
Performance - reference frequency (MHz)	870/550/52
at typical output (dBmV)	43/44/37
Channels	79 analog/320 MHz digital (suppressed by 6 dB)
Crossmod (worst case)	-63 dB
CTB (worst case)	-74 dB
CSO (worst case)	-74 dB
Noise figure	
at 52 MHz	9 dB (with SFE-1) maximum
at 870 MHz	10 dB (with SFE-1) maximum
Interstage equalizer, 8LDR/8/G/II	8 ±1 dB
Hum modulation	-65 dB
Return loss, input/output	16 dB minimum at operational level
Test points, input/output	20 ±0.7 dB
Housing dimensions	10.6 L × 8.0 W × 4.7 D inches (26.9 × 20.3 × 11.9 cm)
Weight	7.2 pounds (3.2 kg)

AC Current

AC Voltage	One-way (typical E-GaAs)	With RA-Kit (typical E-GaAs)
90 Vac	0.48 A	0.56 A
75 Vac	0.50 A	0.59 A
60 Vac	0.56 A	0.65 A
53 Vac	0.60 A	0.70 A
45 Vac	0.67 A	0.78 A
38 Vac	0.75 A	0.88 A

RA-Kit/L Return Amplifier

Parameter	Specification
Passband (S-split)	5 through 40 MHz
Gain, station (minimum)	19 dB
Flatness	±0.50 dB maximum
Level control	Fixed pads, JXP-*B, input and output
Performance	
at typical output	41 dBmV, flat
Channels	4 NTSC
Crossmod (worst case)	-74 dB
Single triple beat (worst case)	-82 dB
Single second order (worst case)	-77 dB
Noise figure	6 dB
Power requirements	24 Vdc, 125 mA

ADU Automatic Drive Unit

Parameter	Specification
Pilot channel	See current catalog
Adjacent channel frequency	±6 MHz
Minimum BLE** output at pilot frequency	+36 dBmV
ALC stiffness	±0.3 output change for ±3.0 dB input change
Power requirement	24 Vdc, 75 mA

Appendix B

Torque Specifications

Torque specifications are valid for all models of the BLE**/.*.

Fastener	Screw Size	Wrench Size	In-lbs	Torque	
				Ft-lbs	N-M
Strand clamp/pedestal mounting	5/16-18	1/2 inch	120-144	10-12	13.6-16.3
Housing/lid closure	1/4-20	7/16 inch	72	6.0	8.1
Test point plugs	5/8-24	1/2 inch	25-40	2.1-3.3	2.8-4.5
Seizure screw	#8-32	3/16 inch or Phillips	12	1.0	1.4
Hybrid	#6-32	Phillips	10-12	0.8-1.0	1.1-1.4
Chassis (E-pack)	#10-32	5/16 inch	18-22	1.5-1.8	2.0-2.4
Chassis cover	#6-32	1/4 inch or Phillips	10-12	0.8-1.0	1.1-1.4
Status monitor	#10-32 triple lead	5/16 inch	24-30	2.0-2.5	2.7-3.4
Power supply cover	#6-32	Phillips	10-12	0.8-1.0	1.1-1.4

Abbreviations and Acronyms

The abbreviations and acronyms list contains the full spelling of the short forms used in this manual.

ADU	Automatic Drive Unit
c/n	carrier-to-noise
CSO	Composite Second Order
CTB	Composite Triple Beat
cw	Continuous wave
dB	Decibel
dBmV	Decibels referenced to one millivolt
E-GaAs	Enhanced Gallium Arsenide
FTEC	Fast Transfer Electronic Crowbar
ICS	Ingress Control Switch
MHz	Megahertz
NTSC	National Television Standards Committee
rms	root-mean-square
RSA	Return for Service Authorization
SAW	Surface Acoustic Wave
SCS-*	Starline Cable Simulator
SFE-*-*	Starline Forward Equalizer
SRE-*-*	Starline Return Equalizer
TDU	Thermal Drive Unit

Visit our website at:
www.motorola.com



506199-001
08/04

MGBI