BAL LINEAR AMPLIFIER SERIES

USER'S MANUAL

P/N: EDA139 (V1.5)



AEROTECH, Inc. • 101 Zeta Drive • Pittsburgh, PA. 15238-2897 • USA

Phone (412) 963-7470 • Fax (412) 963-7459

Product Service: (412) 967-6440; (412) 967-6870 (Fax)

www.aerotech.com

If you should have any questions about the BA Linear Amplifier, comments regarding the documentation, or are looking for manual updates, please refer to Aerotech online at:

<http://www.aerotech.com>.

For your convenience, a product registration form is available at our web site.

Our web site is continually updated with new product information, free downloadable software and special pricing on selected products.

The BAL Linear Amplifier Series User's Manual Revision History:

Rev 1.0	February 27, 1998
Rev 1.1	June 23, 1998
Rev 1.2	May 9, 2000
Rev 1.3	April 6, 2001
Rev 1.3a	July 19, 2001
Rev 1.4	October 11, 2001
Rev 1.5	May 23, 2002

TABLE OF CONTENTS

CHAPTER 1: INTRODUCTION	1-1
1.1. Product Overview	1-1
1.2. Models, Options and Packages	1-2
1.3. BAL Drive Package	1-3
1.4. Hardware Overview and Function	1-5
1.4.1. Motor and AC Power Connections	1-5
1.4.2. DIP Switch	1-6
1.4.3. Potentiometers (POTs)	1-7
1.4.4. Connector J6 and Enable Indicator	1-7
1.4.5. I/O Circuitry	1-10
1.5. Safety Procedures and Warnings	1-12
CHAPTER 2: INSTALLATION AND OPERATION	2-1
2.1. Introduction	2-1
2.2. Jumper Selections	2-1
2.3. Wiring Configurations	2-4
2.3.1. Velocity Command Configuration	2-4
2.3.2. Torque Command Configuration (Current)	2-5
2.3.3. Dual-Phase Command Configuration	2-6
2.4. Three Phase Brushless Motors with Unconnected Phases	2-7
2.5. Power and Control Connections	2-8
2.5.1. Setup – Torque Command Mode (Current)	2-8
2.5.2. Setup – Velocity Command Mode	2-9
2.5.3. Setup – Dual Phase Command Mode	2-11
2.6. DC Brush Motor Operation	2-12
2.6.1. Single Brush Motor	2-12
2.6.2. Multiple Brush Motor	2-13
2.7. Motor Phasing Process	2-14
2.7.1. Determining Phase/Hall Sequence	2-14
2.8. Current Regulator Adjustments	2-16
CHAPTER 3: TECHNICAL DETAILS	3-1
3.1. Part Number and Ordering Information	3-1
3.2. Electrical Specifications	3-2
3.3. BAL Amplifier Dimensions	3-5
CHAPTER 4: TROUBLESHOOTING	4-1
4.1. Amplifier Related Problems	4-1
APPENDIX A: GLOSSARY OF TERMS	A-1
APPENDIX B: WARRANTY AND FIELD SERVICE	B-1
APPENDIX C: CABLE DRAWINGS	C-1
INDEX	
REVISION HISTORY	

▽ ▽ ▽

LIST OF FIGURES

Figure 1-1.	BAL Series Amplifier.....	1-1
Figure 1-2.	Functional Diagram.....	1-4
Figure 1-3.	Amplifier Hardware.....	1-5
Figure 1-4.	Fault Output.....	1-10
Figure 1-5.	Enable/Shutdown Inputs.....	1-10
Figure 1-6.	± Limit Inputs.....	1-11
Figure 1-7.	Hall and Encoder Inputs.....	1-11
Figure 2-1.	BAL Board Assembly with Jumper Locations.....	2-3
Figure 2-2.	Velocity Command Configuration.....	2-4
Figure 2-3.	Torque (Current) Command Configuration.....	2-5
Figure 2-4.	Dual-Phase Command Configuration.....	2-6
Figure 2-5.	Connection of Six Wire Motors to BAL Series Amplifiers.....	2-7
Figure 2-6.	Command Signal Adjustment Portion of the Pre-amplifier Circuit.....	2-10
Figure 2-7.	Single Brush Motor Configuration with Tach.....	2-12
Figure 2-8.	Multiple Brush Motor Configuration.....	2-13
Figure 2-9.	Motor Phasing.....	2-15
Figure 2-10.	Current Command Interface Circuit.....	2-16
Figure 3-1.	BA Linear Amplifier Dimensions.....	3-5
Figure C-1.	BAL Feedback Cable (PFC).....	C-1
Figure C-2.	BAL Light Duty Brushless Motor Cable (PMC).....	C-2



LIST OF TABLES

Table 1-1. BAL Models and Voltage Configurations 1-2
Table 1-2. DIP Switch Functions 1-6
Table 1-3. Potentiometer Functions 1-7
Table 1-4. Connector J6 Pinouts1-8

Table 2-1. Jumper Selections2-2

Table 3-1. Part Number and Ordering Example (BAL20-40-A-AH)..... 3-1
Table 3-2. Part Number and Ordering Options 3-1
Table 3-3. Electrical Specifications3-2

Table 4-1. Amplifier Faults, Causes, and Solutions4-1

Table R-1. RevisionsR-1



CHAPTER 1: INTRODUCTION

In This Section:

- Product Overview..... 1-1
- Models, Options and Packages..... 1-2
- BAL Drive Package..... 1-3
- Hardware Overview and Function..... 1-5
- Safety Procedures and Warnings..... 1-12

1.1. Product Overview

The BAL Series amplifiers are highly reliable brushless servo amplifiers (refer to Figure 1-1) that are easily adaptable to drive brush or brushless servomotors. The BAL amplifier package is a complete modular unit that includes heat sink, metal cover, control and bus power supplies that operate at ± 40 VDC or ± 80 VDC. The BAL drives provide the designer with servo drive flexibility for use in applications such as:

- CMM (Coordinate Measurement Machines)
- x-y stages
- inspection and scanning (w/o Air Bearings)
- medical
- and semiconductor fabrication.



Figure 1-1. BAL Series Amplifier

1.2. Models, Options and Packages

A list of the available models and the voltage configurations is shown in Table 1-1.

Table 1-1. BAL Models and Voltage Configurations

Model	Standard Voltage Configuration	Peak Output Current	Continuous Output Current (peak)
BAL20-40-X	±40 VDC	20A	10A
BAL10-80-X	±80 VDC	10A	5A
BAL10-40-X	±40 VDC	10A	5A

Where:

- X = A for 110 VAC single phase input power.
- X = B for 220 VAC single phase input power.
- X = C for 100 VAC single phase input power.

The BAL drives feature self-commutation with analog or digital Hall effect feedback signals. The BAL drives even include a 5 VDC, 250 mA supply to power encoders and Hall effect devices (HEDs). Each model is jumper selectable, providing the capability to drive both brush and brushless motors. Complete electrical isolation is provided between the control stage and the power stage for all models of the BAL Series. This is accomplished with a transformer isolated control voltage power supply and opto-isolation of the drive signals, current command signals and fault signal between the control and power stages. Each drive is fully protected against the following fault conditions:

- control power supply under voltage
- RMS current limit exceeded
- power stage bias supplies under voltage
- over temperature
- over current
- and excessive power transistor dissipation.

Operating modes include current command, velocity command or dual-phase command (for brushless modes of operation only). For brush modes of operation, the available operating modes are current command and velocity command. Differential inputs are used for better noise immunity. Velocity feedback is from either an encoder or tachometer and logic inputs include directional current limits and shutdown. Fault, current, and velocity outputs simplify monitoring drive status. In addition, there is an option to drive three brush motors in torque mode.

1.3. BAL Drive Package

A block diagram of the BAL Series servo amplifier is shown in Figure 1-2. This is a simplified diagram of the internal modules of the BAL Series amplifier. Contained in the drive is a 115/230 VAC 50/60 Hz step down toroidal isolation transformer that rectifies its output to produce a ± 40 VDC or a ± 80 VDC bus depending on the model.

These buses power three class AB power amplifiers, each containing their own control power supply and isolated current command input connections. These power amplifiers work independently of each other, each only receiving a signal current command from the control section, refer to Figure 1-2. In other words, each power amplifier has a current regulating circuit and voltage regulating circuit, along with an adjustable current limit time-out circuit and a dynamic power limit circuit.

The dynamic power limit circuit monitors the instantaneous power across each output power transistor and clamps the incoming current command signal to a level just below the second breakdown specification of the output transistor.

The current limit time-out circuit monitors the phase current. It sends a signal to the control section to shutdown the entire servo amplifier, if the current in a given phase exceeds a certain level (programmable) after a given time period. This time period is a variable and depends on the amount of current above the programmed current threshold level.

The control section contains its own isolated +5, ± 12 VDC control supply. Depending on the operating mode, the control section is responsible for accepting incoming current or velocity command signals and providing digital or analog commutation processing on these signals. In addition, it generates an internal velocity feedback signal from the encoder, if the velocity mode is specified. Independent of the mode specified, the control section produces three current command signals that are fed through opto-isolation to each of the three amplifiers.

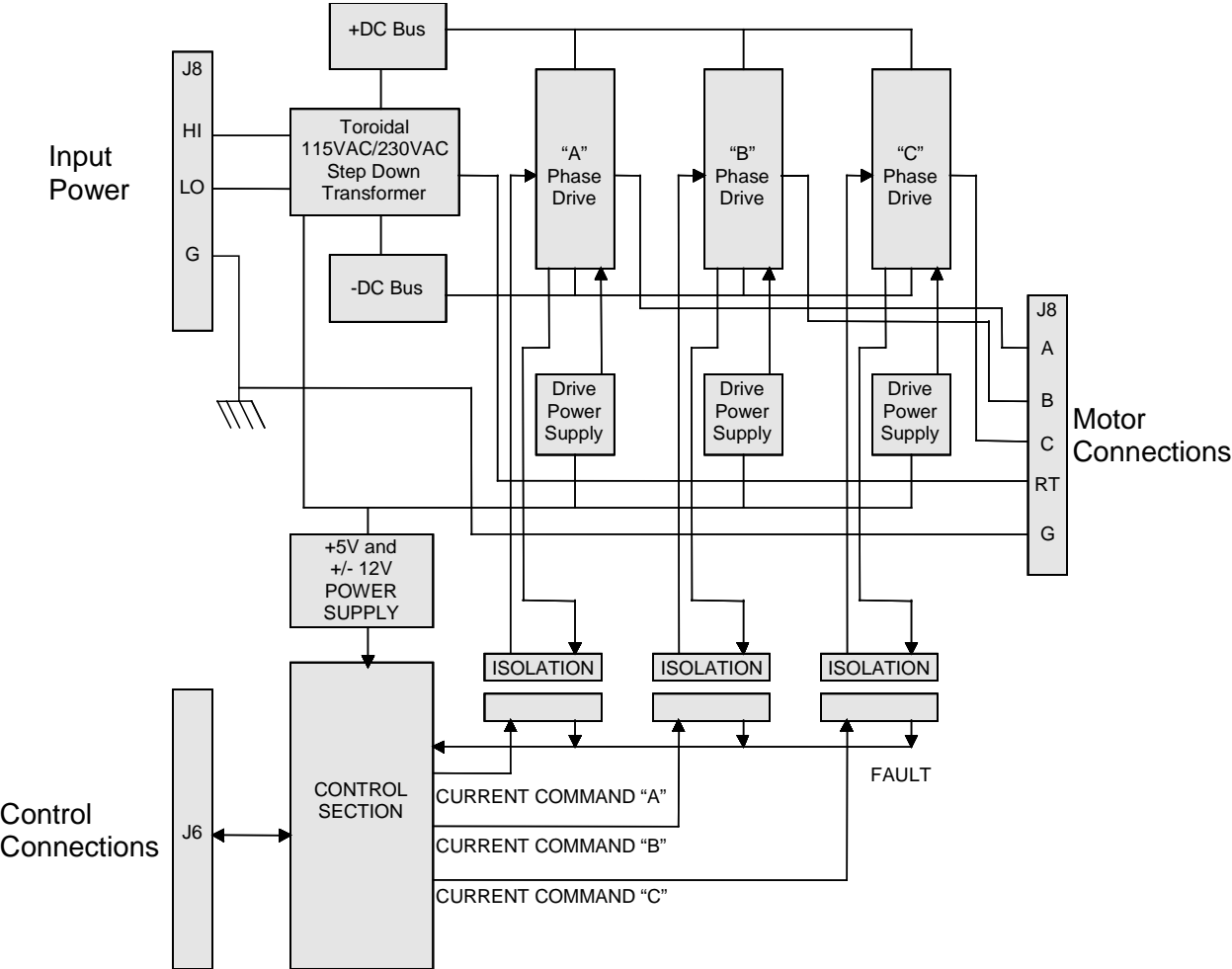

Figure 1-2. Functional Diagram

1.4. Hardware Overview and Function

The BAL Series consist of two power connections (motor power and input power), four potentiometers, a 6-position DIP switch, an enable LED indicator lamp, and a 25-pin "D" style connector. Refer to Figure 1-3 for locations.

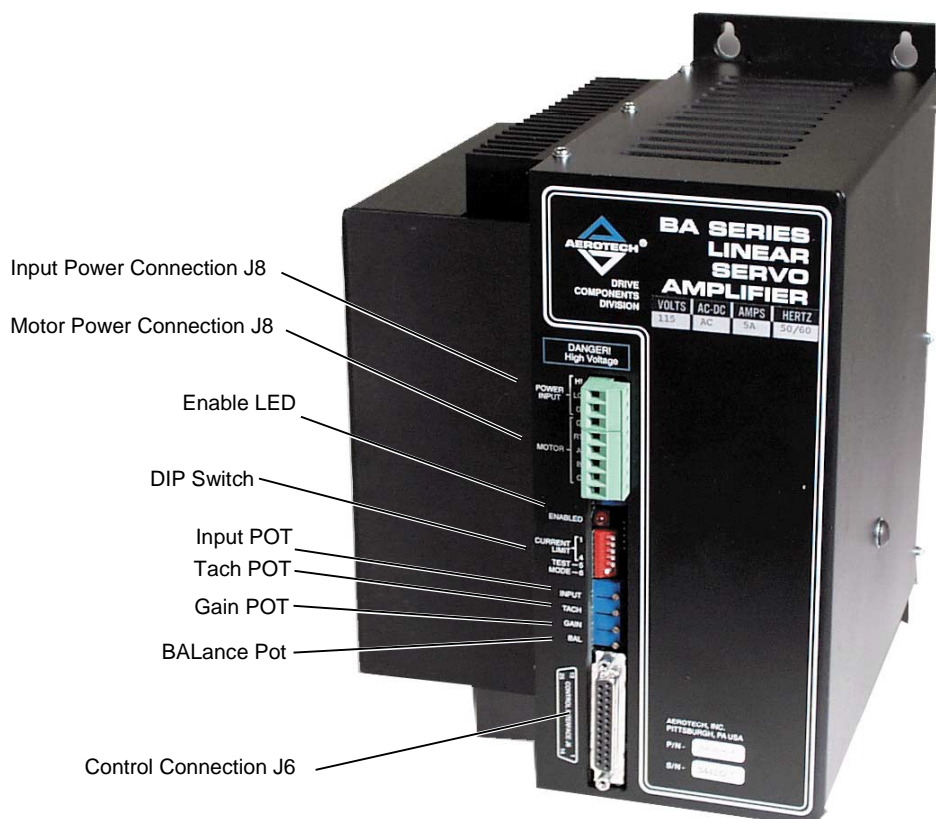
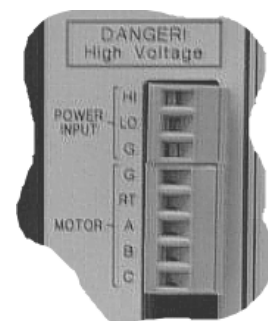

Figure 1-3. Amplifier Hardware

1.4.1. Motor and AC Power Connections

The three phase motor terminal connections are made at connections **A**, **B**, **C**, and **RT** (Return). This area is designated as such on the amplifier.

Input power to the BAL series amplifier is made at the **HI** (line) and **LO** (neutral) terminals with earth ground connected to \perp (or "G" Ground). Motor frame and shield connect to a second Ground (G).



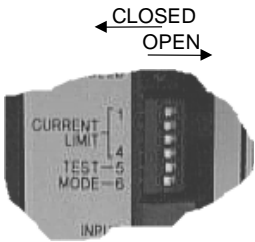

1.4.2. DIP Switch

There is a 6-position DIP switch on the BAL drive that provides three discrete functions. The switch permits the user to control maximum allowable current to the motor (self commutating modes only), velocity or current operational mode, and test mode. Figure 1-3 shows the location of this switch on the BAL drive. Refer to Table 1-2 for the exact switch functions.

Table 1-2. DIP Switch Functions

	Switches	Position	Function
Current Limit Peak (self commutating modes only)	1	closed	Peak is 6% of I _{peak}
	2	closed	Peak is 13% of I _{peak}
	3	closed	Peak is 27% of I _{peak}
	4	closed	Peak is 54% of I _{peak}
Test	5	closed	Closing this position allows the BALance potentiometer to manually control motor velocity or torque without the need of an input signal depending upon the setting of switch 10.
Mode	6		Velocity/Current mode - closing this position enables the current mode.

The following examples should be used as a guideline for setting the DIP switches.

Example for a BAL20 - Setting Continuous Current Limits

To set the continuous current limit to 5.5A:

$5.5\text{A Continuous RMS} \times 1.414 = 7.8\text{A continuous peak}$

$(7.8\text{A continuous peak} / 20\text{A max peak}) \times 100 = 39\%$.

Open switches 1 and 4; close switches 2 and 3.

1.4.3. Potentiometers (POTs)

Potentiometers **INPUT**, **TACH**, **GAIN**, and **BALance** are associated with the pre-amplifier circuit contained in the amplifier. Refer to Figure 1-3 for location of the pots on the BAL drive. These potentiometers are used to adjust the pre-amplifier gain when the **MODE** switch is set for velocity control using an external DC tachometer or incremental encoder for velocity feedback. Refer to Table 1-3 for pot functions.

Table 1-3. Potentiometer Functions

Potentiometer	CW	CCW	Function
GAIN	decrease	increase	This pot adjusts the AC gain of the pre-amplifier.
INPUT	increase	decrease	This pot adjusts the DC gain of the input command present at J6 Pins 8 & 21.
TACH	increase	decrease	This pot adjusts the DC gain of the tach or encoder derived velocity feedback input present at J6-Pin 3.
BALance			Provides the means of canceling small DC offsets that may be present in the pre-amplifier circuit.

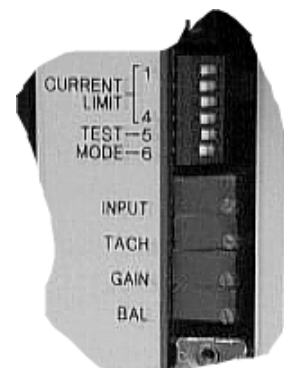

1.4.4. Connector J6 and Enable Indicator

Connector **J6** (25-pin "D" type, female) provides the interface for input and output control connections. Refer to Table 1-4 for connector J6 pinouts. The LED **ENABLE** indicator will illuminate at all times until there is a fault or external shutdown, then the indicator will be off and motor power will be removed. Refer to Figure 1-3 for location of these items.



Table 1-4. Connector J6 Pinouts

Pin #	Input or Output	Signal	Function
Pin 1	shield	ground	Connection point to earth ground. Used for reducing electrical noise in control and feedback signals. Typically connected to the foil shield of a shielded cable.
Pin 2	output	power	On board 5V power supply. Pin 2 is intended for powering an encoder and can supply up to 250mA of current.
Pin 3	input / output	+tach	Tachometer input for velocity feedback, (encoder vs. tach velocity feedback is jumper selectable). A tachometer may be used in the velocity loop configuration to provide negative feedback to the amplifier. This allows the amplifier to close the servo loop and control the stability of the loop. If an encoder is used for velocity feedback, this pin serves as an output for monitoring velocity. (approx. 1V/KRPM)
Pin 4	input ⁽¹⁾	Hall A	Hall effect A. One of three commutation signals used with brushless motors. Used in conjunction with Hall effect B and Hall effect C to provide motor rotor position information to the amplifier. This input is also for connection of analog Hall A, if applicable.
Pin 5	input	cosine	Cosine signal from encoder. Optionally used, in conjunction with sine for deriving an electronic tachometer signal. Line receiver input
Pin 6	input	cosine-N	Compliment of cosine (J6 - 5). Line receiver input.
Pin 7	input	ground	Signal common. Electrical reference for all control circuitry on amplifier.
Pin 8	input	+input	Non-inverting input of differential input circuit. A positive voltage on this input causes CCW motor rotation (torque or velocity mode). For single ended operation, connect command to this input and ground (Pin 21 of J6).
Pin 9	input	icmda	Current command A. Jumper selectable current command input. Bypasses differential input, pre-amplifier, and self commutation circuit.
Pin 10	input ⁽¹⁾	shutdown	Jumper selectable active high or active low input. Used to shut off power stage and therefore remove all power to the motor.
Pin 11	input ⁽¹⁾	+ilmt	Directional current limit input. When pulled to its active state, motion in the positive direction (CW motor shaft rotation) is inhibited (jumper selectable).
Pin 12	input	icmdc	Current command C. Allows control of phase C current when jumper JP8 is set to 2-3. Normally phase C current is derived internally from phase A and B currents.
Pin 13	N.C.		Not used.
Pin 14	signal common	ground	Electrical reference for all control circuitry on amplifier. This pin is intended to be used as the connection point for the signal common of an encoder. (Used in conjunction with Pin 2 as the power supply connections to an encoder.)
Pin 15	input	-tach	Recommended reference input for tachometer. This point is identical to signal common.
Pin 16	input ⁽¹⁾	Hall B	Hall effect B. One of three commutation signals used with brushless motors. Used in conjunction with Hall effect A and Hall effect C. This input is also for connection of analog Hall B, if applicable.

Table 1-4. Connector J6 Pinouts (Continued)

Pin #	Input or Output	Signal	Function
Pin 17	input ⁽¹⁾	Hall C	Hall effect C. One of three commutation signals used with brushless motors. Used in conjunction with Hall effect A and Hall effect B.
Pin 18	input	sine	Sine signal from encoder. Optionally used, in conjunction with cosine for deriving an electronic tachometer signal. Line receiver input.
Pin 19	input	sine-N	Compliment of sine (J6- 18). Line receiver input.
Pin 20	input	power	On board 5V power supply. Same as J6 pin 2.
Pin 21	input	-input	Inverting input of differential input circuit. A positive voltage on this input causes CW motor rotation (torque or velocity mode). For single ended command operation, ground this connection and connect signal to Pin 8 of J6.
Pin 22	input	icmdb	Current command B. Jumper selectable current command input. Bypasses differential input, pre-amplifier, and self-commutation.
Pin 23	output	-fault	Jumper selectable active high or active low (open collector) output. Used to indicate the status of the power stage (amplifier enabled or faulted).
Pin 24	input ⁽¹⁾	-ilmt	Directional current limit input. When pulled to its active state, motion in the negative direction (CCW motor shaft rotation) is inhibited (jumper selectable).
Pin 25	output	-icmd	Current command monitor. Representative of the current command (self commutating modes only).

1. Denotes input pull up to internal +5 V through a 10K resistor.



1.4.5. I/O Circuitry

The following shows the internal circuitry for the BAL amplifier. Note that all of the logic inputs can tolerate +24VDC.

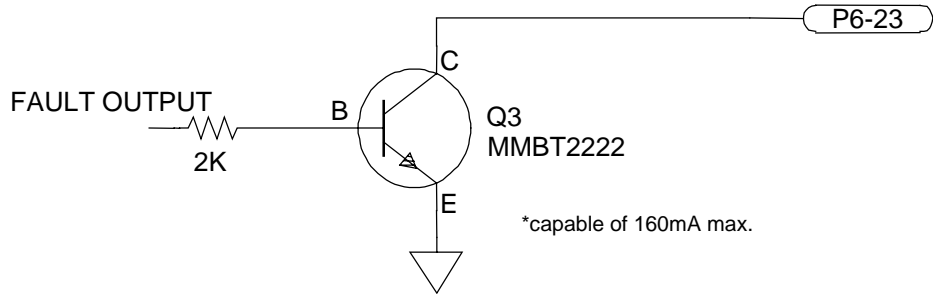

Figure 1-4. Fault Output

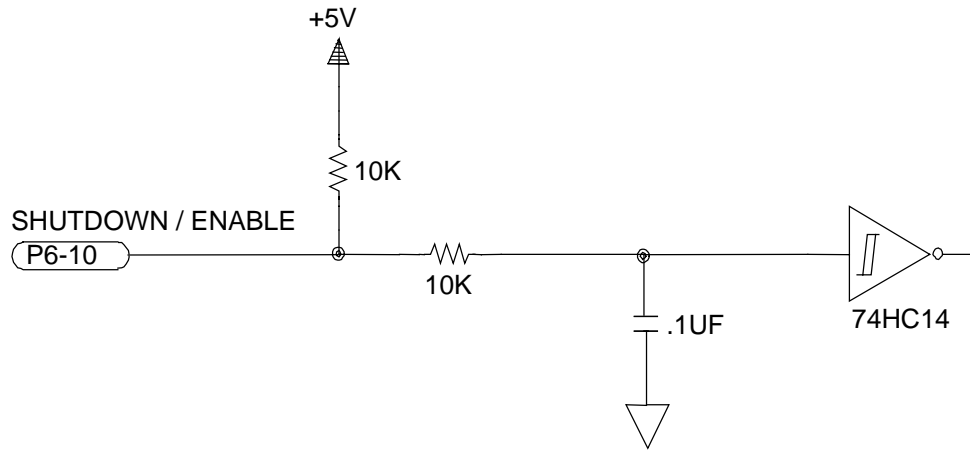

Figure 1-5. Enable/Shutdown Inputs

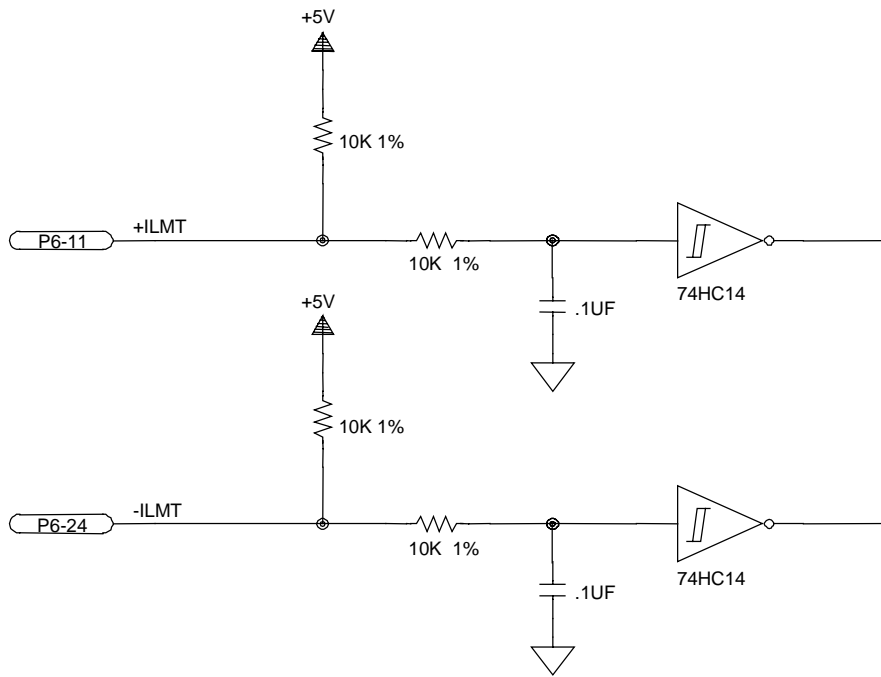

Figure 1-6. ± Limit Inputs

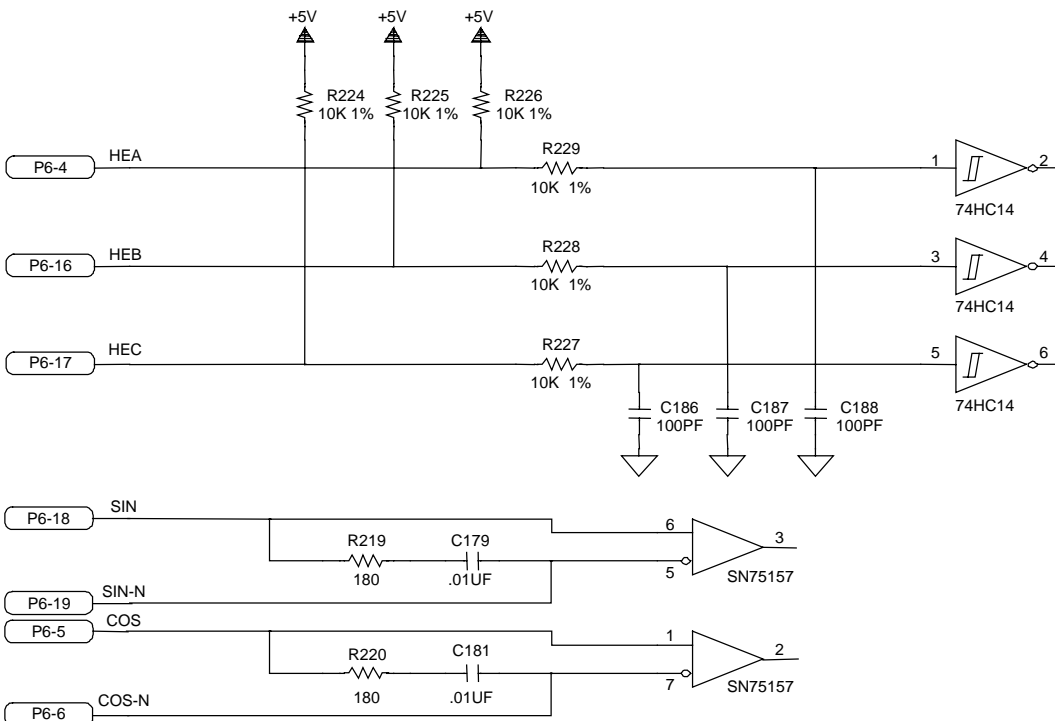

Figure 1-7. Hall and Encoder Inputs

1.5. Safety Procedures and Warnings

The following statements apply wherever the Warning or Danger symbol appears within this manual. Failure to observe these precautions could result in serious injury to those performing the procedures and/or damage to the equipment.



To minimize the possibility of electrical shock and bodily injury, ensure that the motor is decoupled from the mechanical system and no harm to personnel will result if the motor begins to spin.



Before performing the following steps, ensure that the motor is completely disconnected from the amplifier and the associated mechanical system.



To minimize the possibility of electrical shock and bodily injury when any electrical circuit is in use, ensure that no person comes in contact with the circuitry.



To minimize the possibility of bodily injury, make certain that all electrical power switches (all switches external to the amplifier) are in the off position prior to making any mechanical adjustments.

▽ ▽ ▽

CHAPTER 2: INSTALLATION AND OPERATION

In This Section:

- Introduction 2-1
- Jumper Selections..... 2-1
- Wiring Configurations..... 2-4
- Three Phase Brushless Motors with Unconnected Phases..... 2-7
- Power and Control Connections 2-8
- Motor Phasing Process 2-14
- Current Regulator Adjustments 2-16

2.1. Introduction

This section covers the hardware configurations using the switches, jumpers, connectors, and power hook-ups when used with a brush or brushless DC motor. Wiring, grounding, and shielding techniques, an explanation of the current regulator adjustment, and the motor phasing process are also covered in this section.

2.2. Jumper Selections

The BAL Series amplifiers are jumper selectable providing the user with quick reconfiguration capability of operating modes. Table 2-1 lists the jumpers and the default configurations for the amplifiers. Figure 2-1 highlights where the jumpers are located on the board (with the default configurations).

Aerotech brushless motors should be set for 0 degree Hall commutation shift. Motors from other manufacturers may require a 30-degree Hall commutation shift. Consult the motor manufacturer for details.

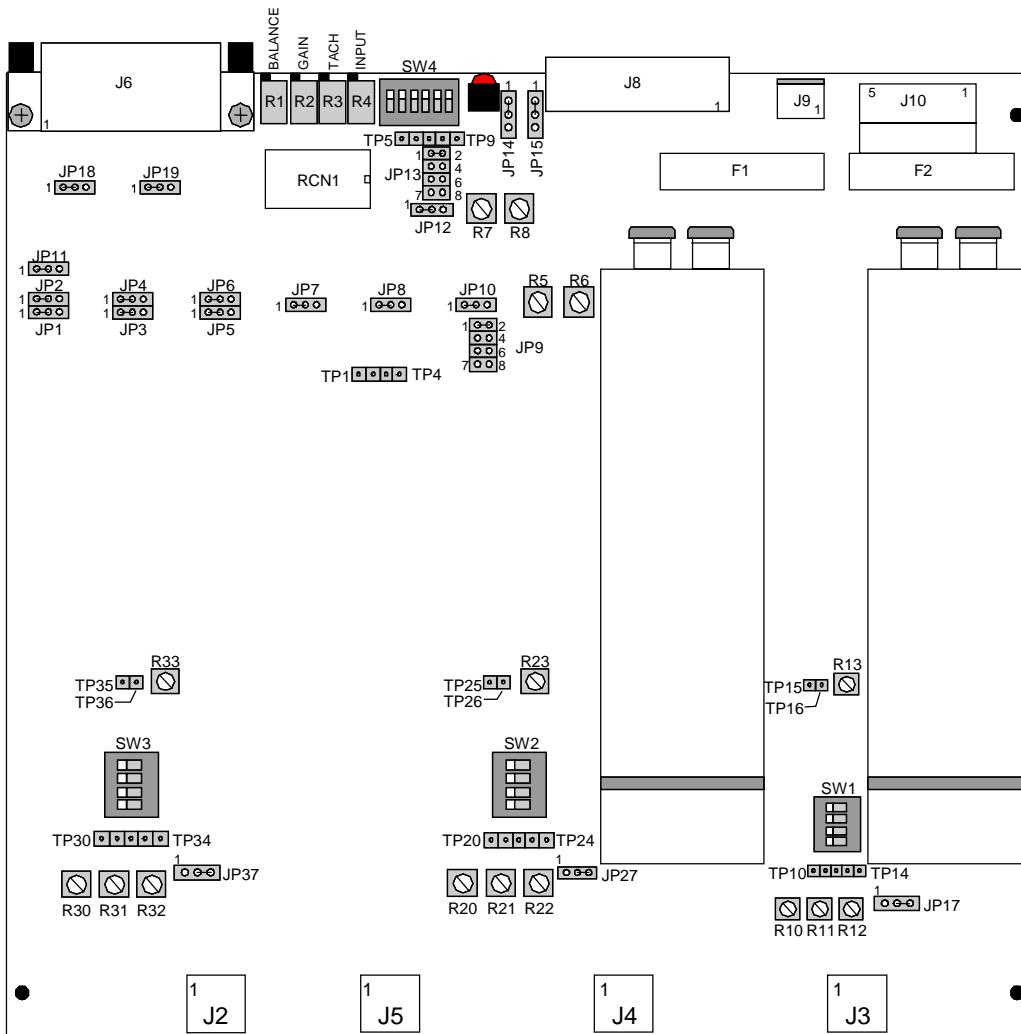

Table 2-1. Jumper Selections

Jumpers	Positions	Function
JP1	1-2	Active low +ILMT. Logic on J6-11 stops CW (+) motor movement (default).
	2-3	Active high +ILMT. Logic on J6-11 stops CW (+) motor movement.
JP2	1-2	Active low -ILMT. logic on J6-24 stops CCW (-) motor movement (default).
	2-3	Active high -ILMT. logic on J6-24 stops CCW (-) motor movement.
JP3	1-2	Selects AC Brushless operation mode (default).
	2-3	Selects DC Brush operation mode.
JP4	1-2	Selects 0 degrees Hall commutation shift for AC Brushless operation(default).
	2-3	Selects 30 degrees Hall commutation shift for AC Brushless operation.
JP5	1-2	Active high fault output. Open collector output on J6-23 goes to high impedance state for drive fault condition (default).
	2-3	Active low fault output. Open collector output on J6-23 is driven to signal common for drive fault condition.
JP6	1-2	Active high shutdown input. Logic high on J6-10 shuts off power stage (default).
	2-3	Active low shutdown input. Logic low on J6-10 shuts of power stage.
JP7	1-2	Internal digital Tach feedback enabled (velocity mode).
	2-3	External Tach feedback through J6-3 (velocity mode) or internal digital Tach feedback disabled (current mode) (default).
JP8	1-2	Phase "C" current command for AC Brushless operation derived internally.(default).
	2-3	Current command for DC Brush operation on phase "C" output (J6-12). Also doubles as phase "C" input for brushless motor operation (J6-12).
JP9	1-2	Phase "A", Phase "B" current command for AC Brushless operation derived internally from digital Hall or analog feedback (default).
	3-4	Phase "A", current command for AC Brushless operation derived externally through pins 9 and 22 of J6 respectively.
	5-6	Phase "A", current command for AC Brushless operation derived internally from analog Hall feedback (factory option).
	7-8	Phase "A", current derived externally through differential inputs (factory option).
JP10	1-2	Phase "A", current commands produced by digital Hall feedback aligned for 30 degree Hall commutation shift.
	2-3	Phase "A", current commands produced by digital Hall feedback aligned for 0 degree Hall commutation shift. (default).
JP11	1-2	Internal velocity circuit disabled. (default)
	2-3	Internal velocity circuit enabled.
JP12	1-2	Phase "B" current commands produced by digital Hall feedback aligned for 30 degree Hall commutation shift.
	2-3	Phase "B" current commands produced by digital Hall feedback aligned for 0 degree Hall commutation shift. (default).
JP13	1-2	Phase "B" current command for AC Brushless operation derived internally from digital Hall or analog feedback (default).
	3-4	Phase "B" current command for AC Brushless operation derived externally through pins 9 and 22 of J6 respectively.
	5-6	Phase "B" current command for AC Brushless operation derived internally from analog Hall feedback (factory option).
	7-8	Phase "B", current derived externally through differential inputs (factory option).
JP14/JP15	1-2	Signal common of control section connected to earth ground (J8 , "G" connections) (default).
	2-3	Signal common not referenced to earth ground.
JP18	1-2	Digital Hall commutation, Phase A Hall.
	3-4	Analog Hall commutation, Phase A Hall. (* Factory Option)
JP19	1-2	Digital Hall commutation, Phase B Hall.
	3-4	Analog Hall commutation, Phase B Hall. (* Factory Option)



JP17, JP27, and JP37 are for factory use only.



Remove cover to gain access to jumpers and test points.

Figure 2-1. BAL Board Assembly with Jumper Locations

Remove AC power from unit before removing cover.

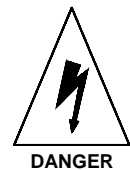

2.3. Wiring Configurations

The BAL amplifiers can be integrated into a system using three basic configurations; velocity command, current command, and dual phase command. Each of these has their advantages and disadvantages depending upon the user's specific needs.

2.3.1. Velocity Command Configuration

In the velocity command configuration, the speed of the motor is controlled by the amplifier. A feedback signal from either a DC tachometer or an incremental encoder is monitored by the amplifier. From this signal, the amplifier adjusts the velocity of the motor accordingly depending upon the velocity command from the external controller. In this configuration, the amplifier closes and controls the velocity loop. The velocity command configuration is shown in Figure 2-2. This configuration can drive both brush and brushless DC motors.

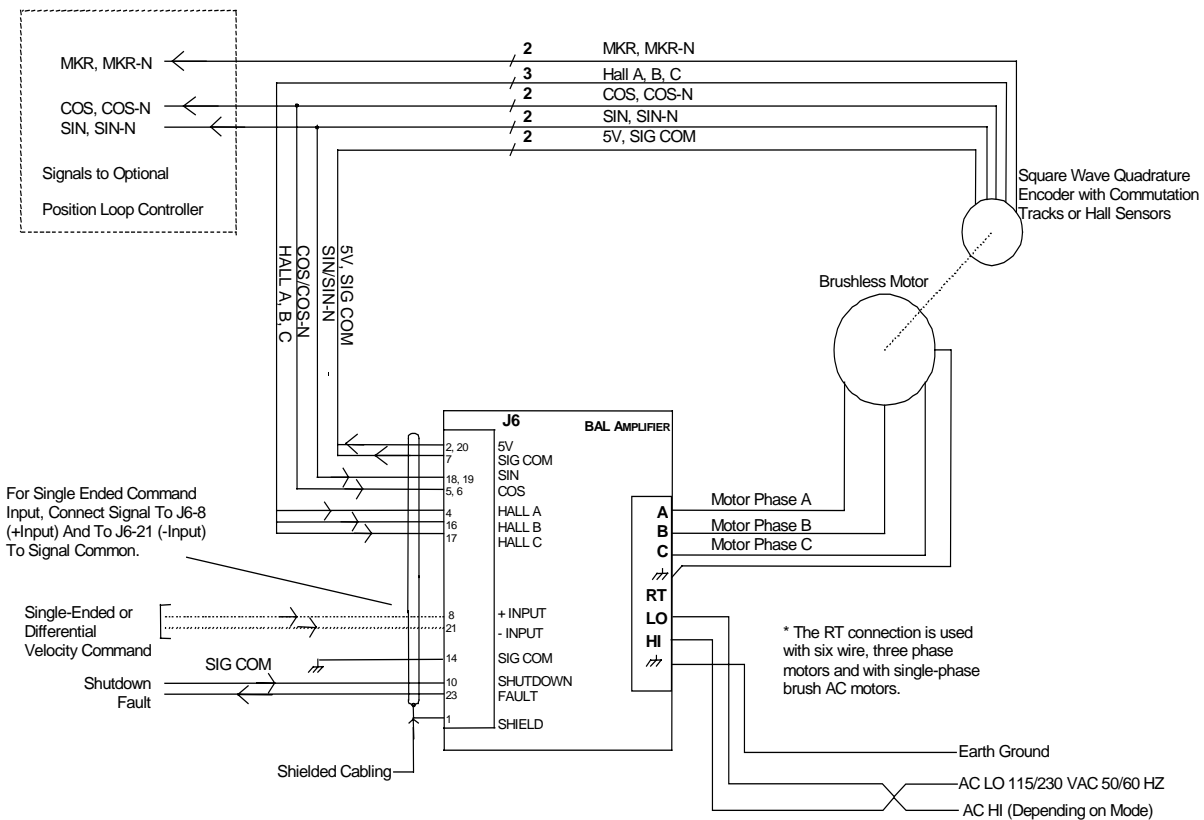

Figure 2-2. Velocity Command Configuration

2.3.2. Torque Command Configuration (Current)

In this configuration, the output current to the motor is proportional to the current command input. The current command configuration is shown in Figure 2-3. The advantage to this configuration is the sine and cosine signals to the amplifier and a tachometer are not required. This configuration will also drive both brush and brushless DC motors.

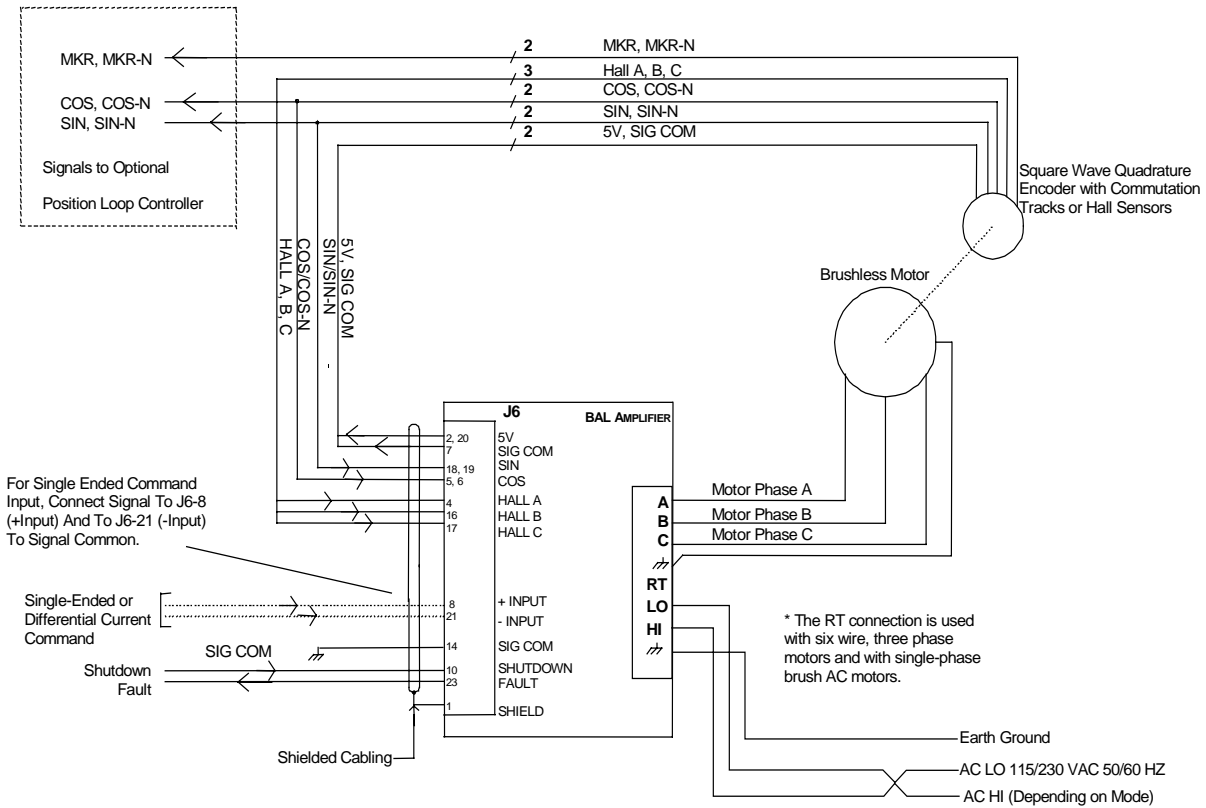

Figure 2-3. Torque (Current) Command Configuration

2.3.3. Dual-Phase Command Configuration

This mode is used with a brushless motor only. In this configuration, the differential input, pre-amplifier, and self-commutation circuits are bypassed. The dual-phase inputs are sinusoidal and are 120° out of phase from each other. The third phase is generated by the amplifier. The dual-phase command configuration is shown in Figure 2-4. The advantage to this configuration is that it provides the smoothest possible motion.

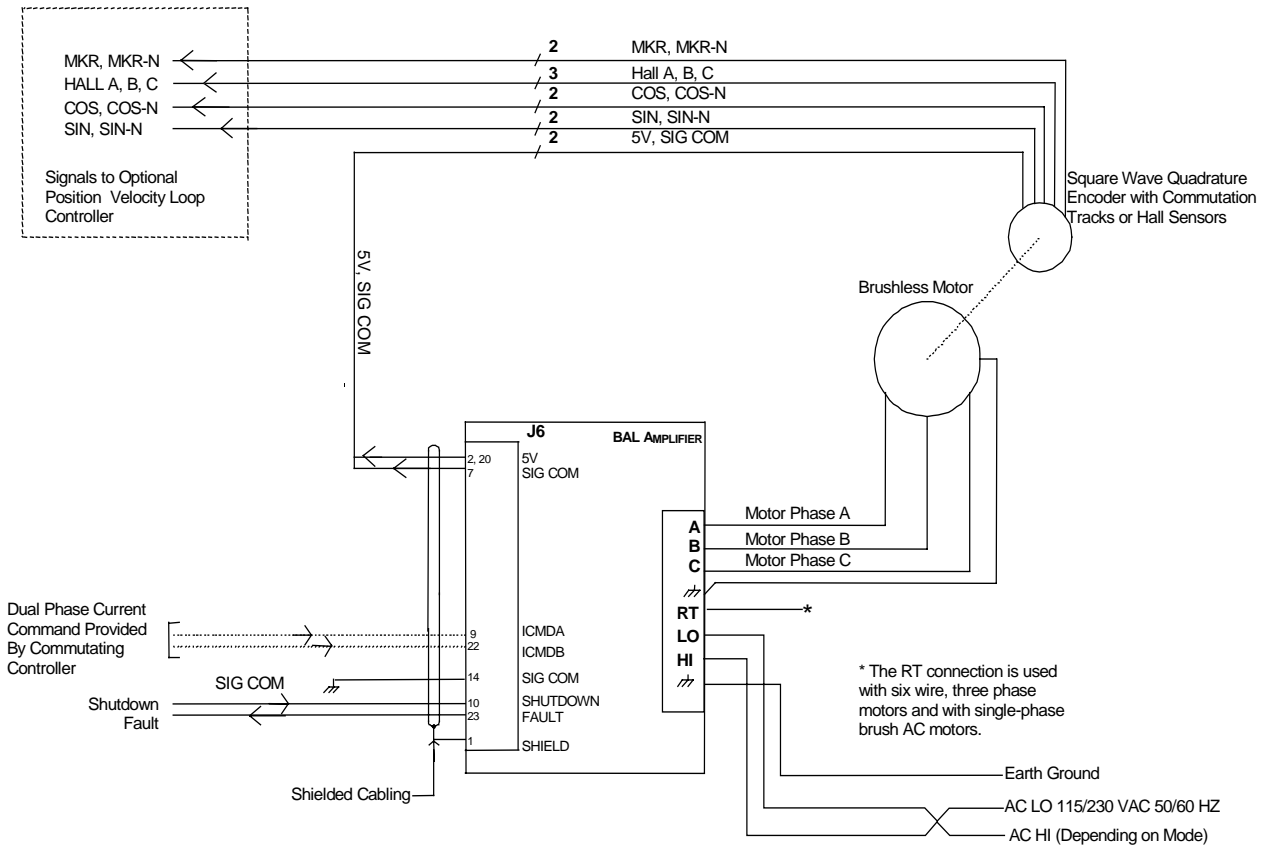

Figure 2-4. Dual-Phase Command Configuration

2.4. Three Phase Brushless Motors with Unconnected Phases

Most three phase brushless motors require only three connections between the servo amplifier and the motor. This is due to the motor phases internally connected in a Wye or Delta style. This form of connection simplifies wiring, ensuring that the servo amplifier only controls and monitors two phase currents, since the third phase current is always the sum of the first two phase currents.

However, this simplicity has one drawback. This drawback is phase winding imbalances that can cause torque ripple and make it difficult to compensate, since the servo amplifier only controls two of the three phase currents. The BAL Series amplifier over comes this problem by providing the "RT" (return) connection for six wire motors, like the Aerotech BLM Series linear motors.

Since the BAL Series amplifier independently controls current in each of its three phases, six wire motors can be connected as shown in Figure 2-5. In this configuration, offset and/or gain adjustments of current made in one phase do not affect those set in the other two phases.

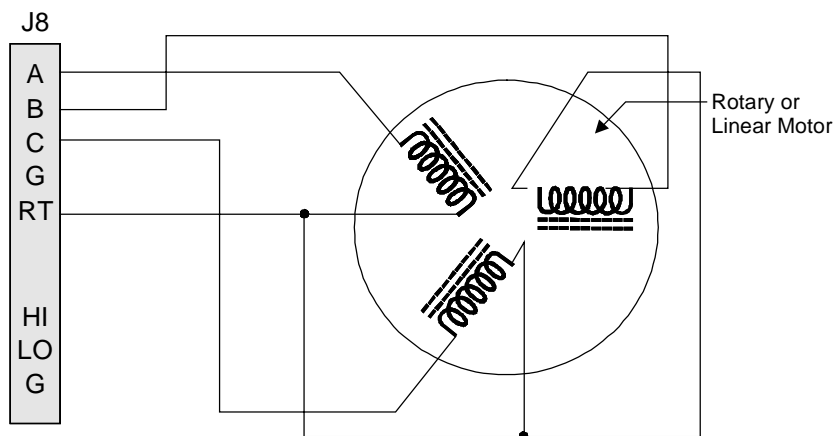

Figure 2-5. Connection of Six Wire Motors to BAL Series Amplifiers

2.5. Power and Control Connections

The BAL drives can be wired into a system in one of two ways depending upon the desired mode of operation. Command signals can be referenced to velocity or torque (current) control signals. The user has access to four potentiometers, three that adjust gain while the fourth (BALance) compensates for input signal offsets. Figure 2-6 illustrates a portion of the pre-amplifier circuit that is accessible to the user for adjusting command signal gains.



For adjustments in gain roll-off, “Personality Module” **RCN1**, pins 1-16, 2-15, 3-14, 5-12, and 7-10 are provided for the selection of the appropriate resistor/capacitor pair. Factory default values are shown in Figure 2-6.

2.5.1. Setup – Torque Command Mode (Current)

To setup the pre-amplifier circuit for use in the torque (current command) mode, configure the BA amplifier as follows:

- Place SW4 position 6 (mode) to closed (**default**)
- Place SW4 position 5 (test) to open (**default**)
- SW4 positions 1 through 4 selects current limit
- Potentiometers “INPUT” set full CW and “GAIN” set full CCW to provide a transconductance gain of ± 10 volts for full current output. “BALance” and “TACH” have no effect.
- JP7 set to 2-3 (**default**)
- JP9 and JP13 set to 1-2 (**default**)
- JP3 set to 1-2 (**default**) for brushless motor operation or 2-3 for brush motor operation
- JP10, JP12, set to 2-3 and JP4 set to 1-2 for zero (0) degrees commutation (**default**) or JP10, JP12 set to 1-2 and JP4 set to 2-3 for thirty (30) degrees commutation (brushless motor operation only).
- Set JP8 to 1-2 (**default**)

With this configuration, an input signal of ± 10 volts to pins **+INPUT** and **-INPUT** will produce the maximum current output signal (viewed at J6 pin 25 **ICMD**) of ± 6 volts. Switch “SW4” 1 through 4 are used to scale this ± 6 volt signal from zero to maximum current. Refer to Figure 2-3 for torque command configuration.

2.5.2. Setup – Velocity Command Mode

For this mode, a velocity feedback signal is required. This feedback signal can be derived from two sources. From an analog DC tachometer that is connected to the +**TACH** pin or from an incremental encoder that is connected to the sine and cosine pins (refer to Figure 2-2). To setup the pre-amplifier circuit for use in the velocity command mode, configure the BAL amplifier as follows:

- Place SW4 position 6 (mode) to open
- Place SW4 position 5 (test) to open (**default**)
- SW4 positions 1 through 4 selects current limit
- Potentiometers “INPUT”, “GAIN”, “BALance”, and “TACH” adjust pre-amplifier gain and offset.

For most applications under the velocity command mode, the preferred starting point for setting the three gain pots is as follows:

INPUT pot - 1/3 CW from full CCW

TACH pot - full CW

GAIN pot - full CW

These initial settings will usually generate a stable system if it is assumed that the tach feedback gain is around 6 volts/Krpm, or if an encoder is used and the line resolution is between 1,000 and 1,500 per revolution.



- JP7 set to 1-2 for encoder or 2-3 (**default**) for tachometer velocity feedback
- JP9 and JP13 set to 1-2 (**default**)
- JP3 set to 1-2 (**default**) for brushless motor operation or 2-3 for brush motor operation
- JP10, JP12 set to 2-3 and JP4 set to 1-2 for zero (0) degrees commutation (**default**) or JP10, JP12 set to 1-2 and JP4 set to 2-3 for thirty (30) degrees commutation (brushless motor operation only).
- Set JP8 to 1-2 (**default**)

NOTE: For single ended command input, connect signal to P1-8 (+input) and the P1-21 (-Input) to signal common.

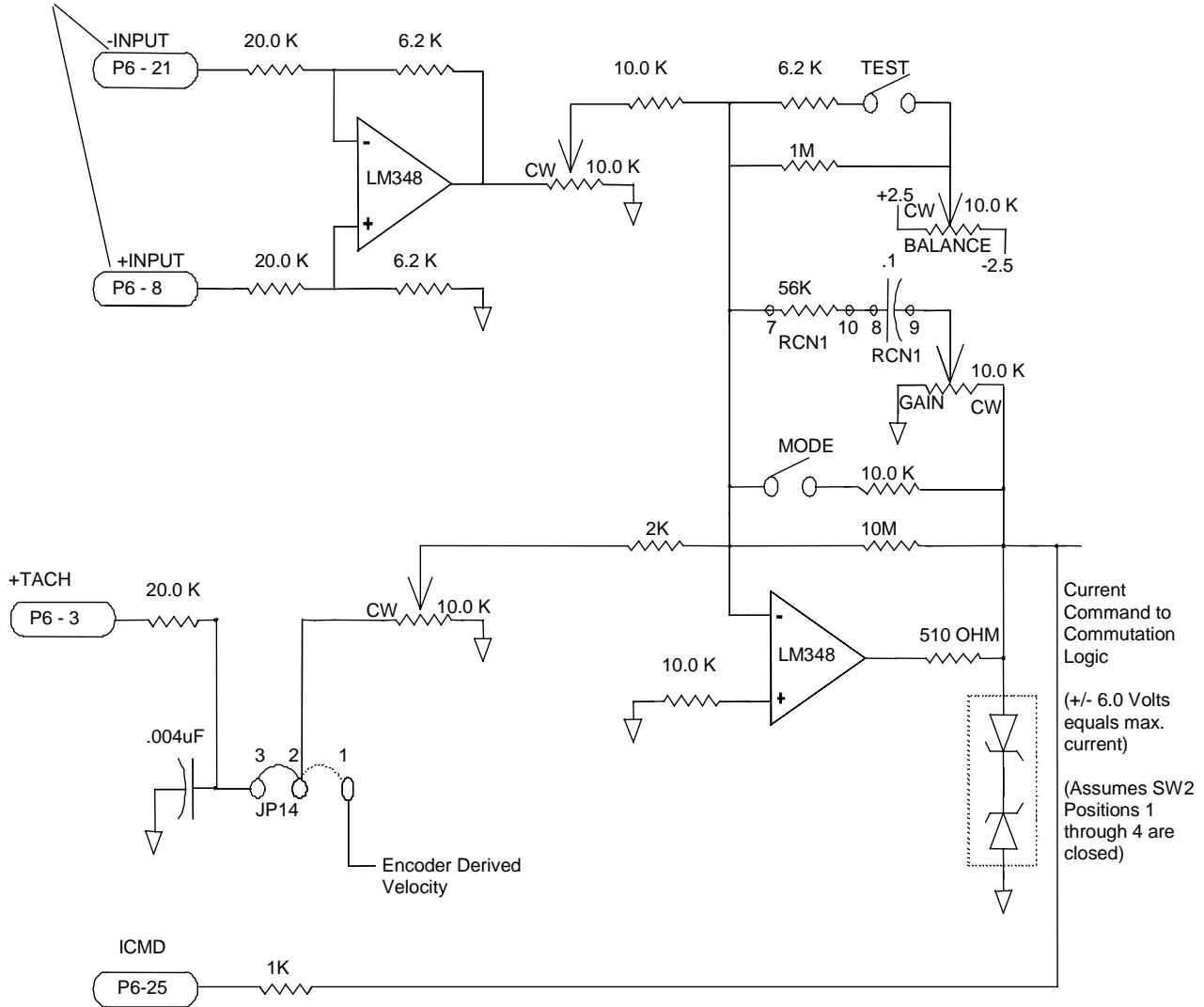

Figure 2-6. Command Signal Adjustment Portion of the Pre-amplifier Circuit



To minimize the possibility of electrical shock and bodily injury, ensure that the motor is decoupled from the mechanical system to avoid personal injury if the motor begins to spin.

Starting with a zero input command signal, apply power to the amplifier. If the motor spins uncontrollably, remove power and switch the polarity of the tach input signal. If an encoder is being used, switch the sine and cosine input signals. Verify compliment signals (sin & sin-N, cos & cos-N) are of correct phasing.

Again, apply power to the amplifier. If the motor begins to oscillate, turn the **TACH** pot CCW until the oscillation stops. The **GAIN** and **TACH** potentiometers can be adjusted to provide maximum stiffness on the motor shaft.

If the desired stiffness is unattainable, the components connected to personality module **RCN1** pins 5-12 and 7-10 may need to be changed.



The **BALance** pot is used to cancel any bias in the internal or external control circuit that would cause the motor to rotate when the input command signal is zero.

If the **TEST** switch is closed the effects of the **BALance** pot are greatly magnified. This is useful when a test bias signal is desired (for velocity or torque modes) to be applied to the amplifier without introducing an external command signal.

2.5.3. Setup – Dual Phase Command Mode

To setup the pre-amplifier circuit for use in the dual phase mode, configure the BA amplifier as follows:

- JP9 and JP13 are set to 3-4
- JP8 is set to 1-2 (**default**).

This mode is used with brushless motors only. Refer to Figure 2-4 for dual phase command configuration.

2.6. DC Brush Motor Operation

The BAL can control up to three brush motors. There are two different configurations for brush mode operation.

2.6.1. Single Brush Motor

In this mode, a brush motor can be controlled in either velocity mode or current mode, refer to Figure 2-7. The connection of the motor phase to the amplifier is done through phase A and phase C. This configuration allows the motor to see the entire bus. Meaning, if a BAL10-40 is the amplifier, then the brush motor will have 80 volts across its terminals and a BAL10-80 will put 160 volts across the motor terminals (Differential at full speed). Connecting the "+" side of the motor to A and "-" to the RT (Return) allows the motor to operate in a single-ended mode. This means that the A terminal will swing plus and minus with respect to RT. For a BA10-40, the motor will only see +40V or -40V maximum; not 80V. This permits lower voltage DC motors to be used safely with BAL. The jumper settings for velocity or torque mode can be found in Section 2.5.1. and Section 2.5.2.

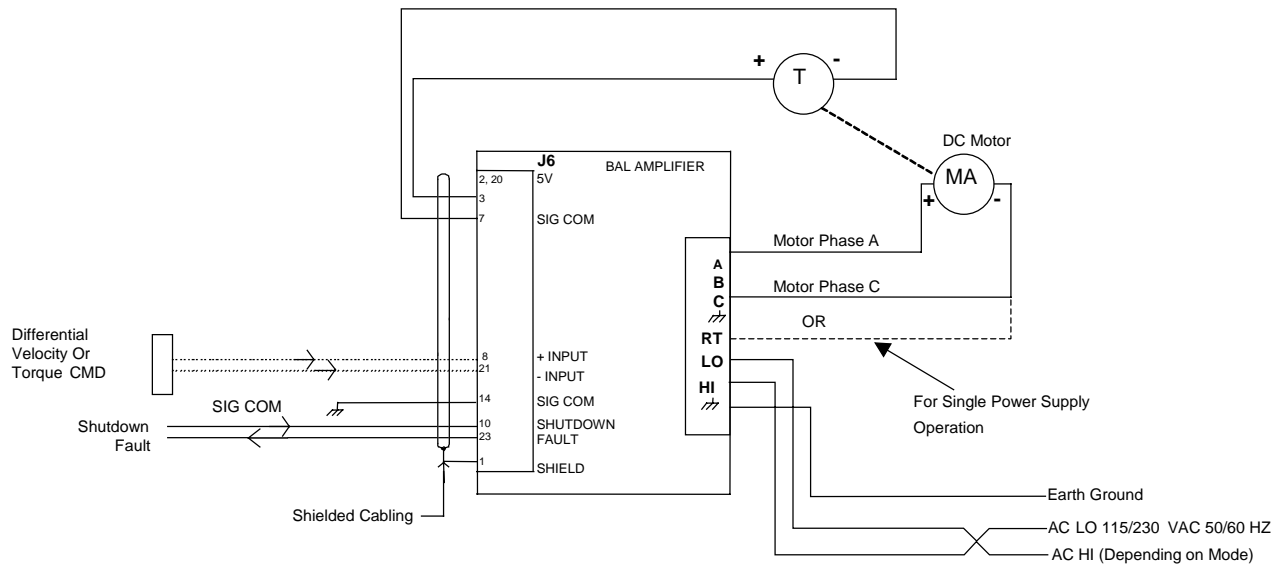

Figure 2-7. Single Brush Motor Configuration with Tach

2.6.2. Multiple Brush Motor

The BAL can control up to three brush motors in torque mode, refer to Figure 2-8. In this mode, "motor +" of each motor connects to the appropriate phase on the amplifier and the "motor -" connects to the return (RT). While operating in this mode, each motor can only see half of the bus. Meaning, BAL10-40 drops 40 volts across the motor and a BAL10-80 drops 80 volts across the motor. The jumper configurations for this mode are:

- JP9 and JP13 set to 3-4
- JP8 set to 2-3.
- JP3 set to 2-3.

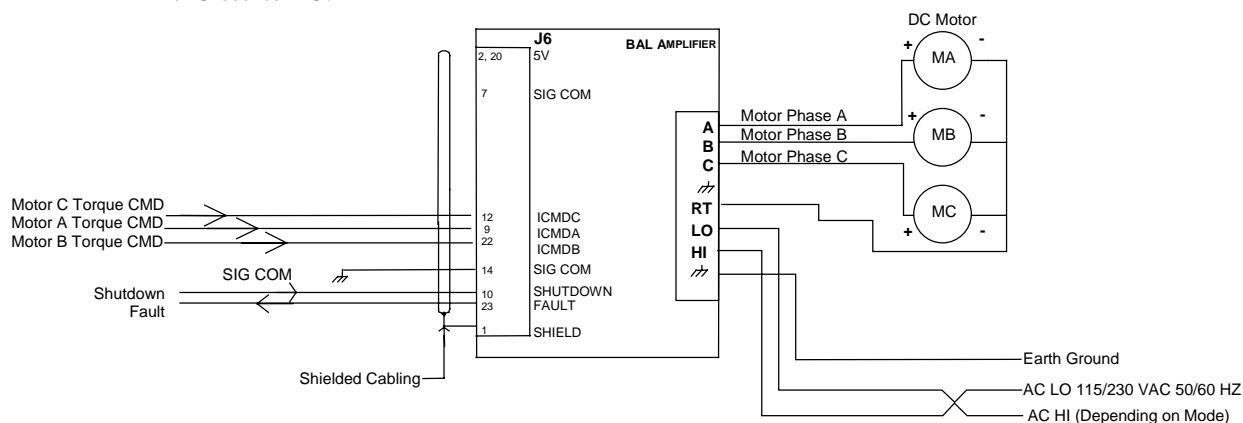

Figure 2-8. Multiple Brush Motor Configuration

2.7. Motor Phasing Process

When configuring the BAL amplifier to run a brushless motor, the commutation signal input connections (labeled HALL A, B, C on connector J6 in velocity or torque command mode pins 4, 16, and 17) are necessary. Two sequences of 30° or 0° (**default**) signal shift can be used, depending on the setting of jumpers JP4, JP10, and JP12. These sequences and the generated output motor phase voltages (motor output connections A, B, and C with respect to a real or pseudo neutral connection) are shown in Figure 2-9. The voltages generated are made under the conditions of a positive signal placed at **+INPUT** with respect to **-INPUT** at control signal input/output connector J6. A “0” for the given HALL input indicates zero voltage or logic low, where a “1” indicates five volts or logic high.



If an Aerotech brushless motor is used with the BAL amplifier, motor phase and HALL connections can be easily determined by referring to the system interconnection drawings in Figure 2-2, Figure 2-3, and Figure 2-4.

2.7.1. Determining Phase/Hall Sequence

For a motor with an unknown phase/hall sequence, a simple test can be performed on the motor to determine the proper connections to the BAL amplifier.

Before performing the following steps, ensure that the motor power leads are completely disconnected from the amplifier.

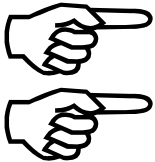

The tests outlined below do not require that the amplifier be turned on since Figure 2-7 illustrates the generated output voltage of the amplifier relative to the input Hall sequences.

The equipment needed for this test is a two-channel oscilloscope and three resistors (typically 10 Kohm, 1/2 watt) wired in a “Wye” configuration.

Connect the ends of the three resistors to motor terminals A, B, C. Use one channel of the oscilloscope to monitor motor terminal A with respect to the “Wye” neutral (i.e., the point where all three resistors are connected together). Turn the shaft of the motor CCW and note the generated voltage. This voltage represents the “phase A to neutral” CEMF. With the second oscilloscope probe, determine the Hall switch that is “in phase” with this voltage. Similarly, phase B and C should be aligned with the other two Hall switches.

Refer to Figure 2-9 and note the generated output voltages of the amplifier relative to the Hall sequences applied to **HALL A**, **HALL B**, and **HALL C** connections at connector **J6**. For proper operation, the CEMF generated motor phase voltages should be aligned to the amplifier's output generated voltage with the given Hall effect sequence shown in.

If the sequence of Hall signals relative to the generated motor voltage (e.g. motor CEMF) is adhered to as illustrated in Figure 2-9; a positive (+) voltage signal applied to pin 8 (+INPUT) of connector J6 relative to pin 21 (-INPUT) of J6 or pin 14 (signal common) of J6 produces a CCW (e.g., a negative rotation) rotation of the motor shaft as viewed from the front of the motor.

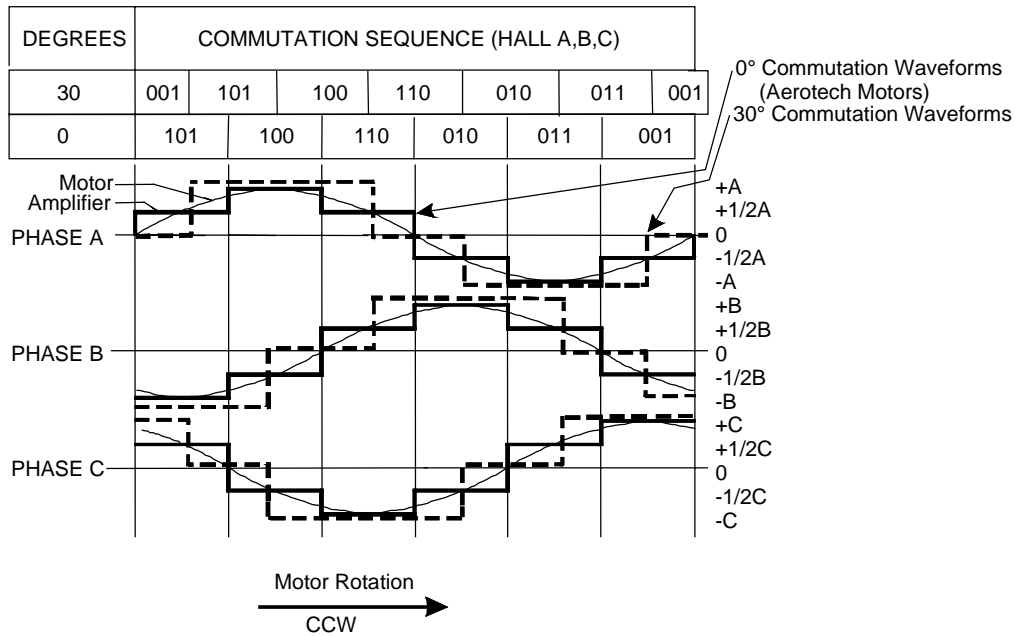

Figure 2-9. Motor Phasing

2.8. Current Regulator Adjustments

The nature of a linear amplifier, especially a high voltage amplifier like the BAL Series amplifier, requires current regulator adjustments be made at the factory. Consequently, there is no information provided here for adjustment of current regulator gains.

However, input gain adjustments can be made if necessary. Figure 2-10 shows the jumper connections JP9 and JP13 used to select the source of the current command signals (Sections 2.5.1., 2.5.2., and 2.5.3. describe jumper settings). In addition, Figure 2-10 shows selectable resistors (RCN1 4-13, 6-11, 8-9) for adjustment of the current command gain.

The default values of 6.8 K ohm provided a scale factor of +/- 10 volts equal to maximum current, where **maximum current** is 10 amps for the BAL10 and 20 amps for the BAL20.

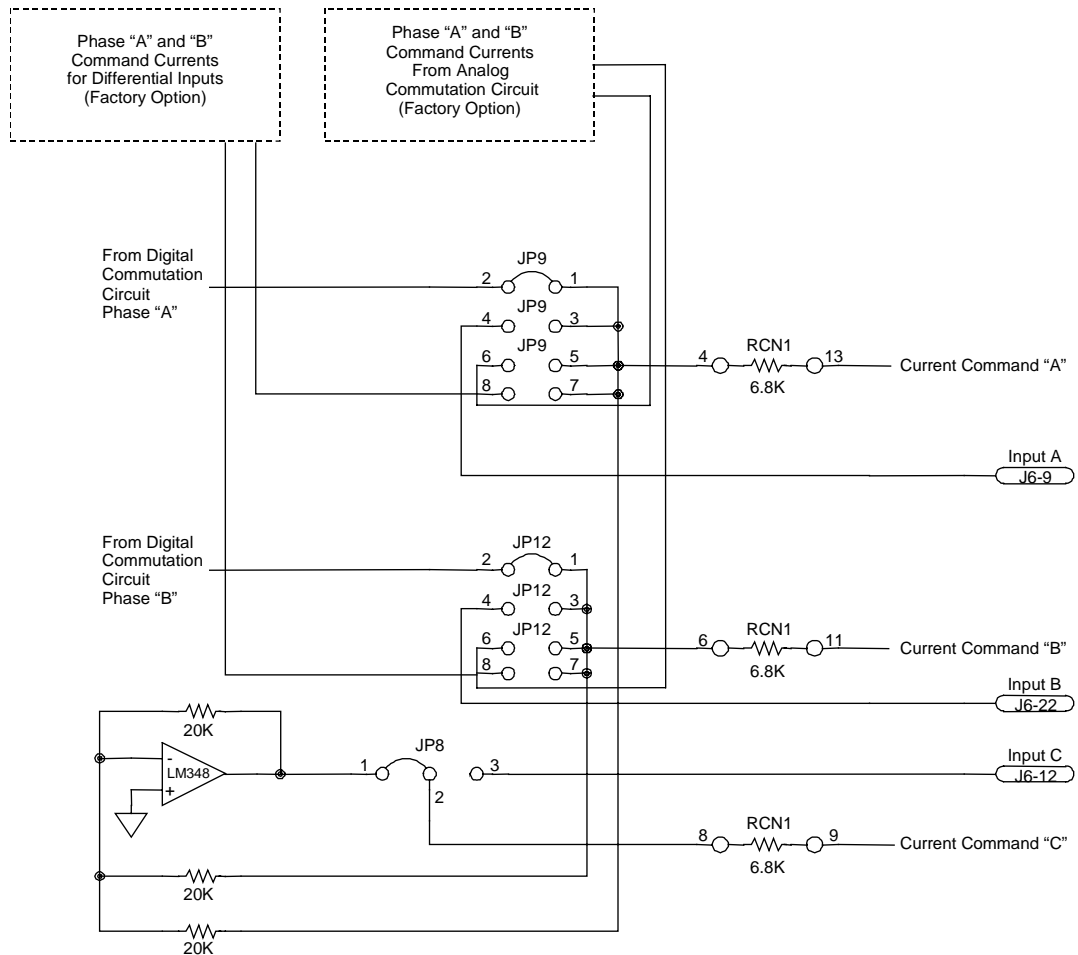

Figure 2-10. Current Command Interface Circuit



CHAPTER 3: TECHNICAL DETAILS

In This Section:

- Part Number and Ordering Information3-1
- Electrical Specifications3-2
- BAL Amplifier Dimensions3-5

3.1. Part Number and Ordering Information

Order information regarding part numbers, models and packages is shown below in Table 3-1 and Table 3-2.

Table 3-1. Part Number and Ordering Example (BAL20-40-A-AH)

BAL	20	-40	-A	-AH
Amplifier Series	Output Current	Operating Bus Voltage	Input Voltage	
	10 = 10 A Peak, 5 A Cont. 20 = 20 A Peak, 5 A Cont. (± 40 VDC Bus only)	40 = ±40 VDC Output 80 = ±80 VDC Output	A = 115 VAC B = 220 VAC	AH = Analog Halls (optional)

Table 3-2. Part Number and Ordering Options

BAL Series Linear Amplifiers	
BAL10-40-x	Brushless linear amplifier with ±40 V output (80 V bus) and 10 A peak current, with cooling fan and isolation transformer.
BAL10-80-x	Brushless linear amplifier with ±80 V output (160 V bus) and 10 A peak current, with cooling fan and autotransformer.
BAL20-40-x	Brushless linear amplifier with ±40 V output (80 V bus) and 20 A peak current, with cooling fan and autotransformer.
	x = A for 110 VAC single phase input power (standard) x = B for 220 VAC single phase input power x = C for 100 VAC single phase input power
BAL Series Amplifier Options	
-AH	Replace digital HED input with analog HED input
Feedback Cables	
BFC-15	Feedback cable, BM series brushless motor to controller, 15 ft., MS, DB25
PFC-15	Feedback cable, BM series brushless motor to controller, 15 ft., MS, FL
BFCD-15	Feedback cable, BMS series slotless motor to controller, 15 ft., DB25, DB25
Motor Power (Brushless) Cables	
PMC-15	Motor power cable, BAL amplifier to : BM75, BM130, BM200, BM250, 15 ft.
PMC1-15	Motor power cable, BAL amplifier to : BM500, BM800, BM1400, 15 ft.
PMC2-15	Motor power cable, BAL amplifier to : BM2000, BM3400, BM4500, 15 ft.
PMCHPD-15	Motor power cable, BAL amplifier to BMS series motors, 15 ft.
Control Cables	
BAC2-3	Amplifier cable, BAL amplifier to control for brushless series motors, 3 ft.
BAC6-3	Amplifier cable, BAL amplifier to control for DC brush series motors, 3 ft.

3.2. Electrical Specifications

The electrical specifications and connector J6 pinouts for all BAL drive models are listed in Table 3-3.

Table 3-3. Electrical Specifications

Model	Units	BAL20-40	BAL10-40	BAL10-80
Output Voltage (brushless) ¹	VDC	80	80	160
Input Voltage	VAC	115 to 240		
Output Voltage (brush)	VDC	40	40	80
Peak Output Current	A _{pk}	20	10	10
Continuous Output Current	A _{pk}	10	5	5
Pk Power Dissipation (per phase) ²	Watts	300		
Peak Output Power ³	Watts	1,350		
Continuous Output Power ³	Watts	675		
Pre-amplifier Gain	dB	100		
Power Amplifier Gain (each phase) ²	A/V	2	1	1
Power Amplifier Bandwidth	kHz	2	2	2
Minimum Load Inductance	mH	0.5	1	1
Minimum Load Resistance (line-to- neutral)	Ohms	0.5		
Operating Temperature	°C	0 to 50		
Storage Temperature	°C	-30 to 85		
Weight	lb (kg)	17.3 (7.9)		
<p>1. The BAL Series can drive each of its phases “rail to rail” since the drive supply for each phase is not derived from the +/- bus voltages. 2. Each phase of the BAL Series contains an instantaneous power limit circuit that allows a maximum amount of power dissipation to exist on each of the output power transistors under any operating condition. 3. This specification based on the output power transistors in the saturated (e.g., full on) condition.</p>				
Modes of Operation (jumper selectable)	<p>Brushless:</p> <ul style="list-style-type: none"> - single current command with on-board 6 step (or sine wave [optional]) commutation from HED inputs. - dual phase commands with sinusoidal commutation provided by an external motion controller, third phase command is derived from the amplifier. - velocity command with 6-step (or sine wave [optional]) commutation from HED inputs and velocity feedback from the tach or encoder. <p>Brush:</p> <ul style="list-style-type: none"> - single current command. - velocity command with velocity feedback from the tach or encoder. 			
	<p>- +input-Pin 8, -input-Pin 21: Differential inputs for current or velocity commands, 0 to ± 10 VDC input. “+input” (non-Inverting input) can be used in single ended fashion. A positive voltage on this input causes CCW motor rotation. “-input” (inverting input) can be used in single ended fashion. A positive voltage on this input causes CW motor rotation.</p> <p>- icmda-Pin 9, icmdb-Pin 22: icmdc-Pin 12 phase, ±10V input. ICMDA (current command A) and ICMDB (current command B) are jumper selectable current command inputs. They bypass the differential input, pre-amplifier, and self commutation circuit. They are to be used with controllers that provide external velocity loop and commutation control. (icmdc optional)</p>			

Table 3-3. Electrical Specifications (Continued)

Feedback Inputs	<ul style="list-style-type: none"> - Hall A-Pin 4, Hall B-Pin 16, Hall C-Pin 17: HED inputs for commutation, 0 to 5 VDC, internal pull-up, 10K input. Commutation signals used with brushless motors to provide motor rotation position information to the amplifier. This allows the amplifier to steer the three phases of the motor currents in such a fashion so as to provide rotation of the motor in the desired direction at the desired speed. TTL level input for digital; analog for sine wave (optional). - sine/sine-N-Pin 18, Pin 19, cosine/cosine-N-Pin 5, Pin 6: Encoder inputs for velocity feedback, single ended 0 to 5VDC TTL, internal pull-up, 10K input. Sine and cosine are optionally used in conjunction with one another for deriving an electronic tachometer signal. - +tachometer-Pin 3: Tachometer input for velocity feedback, (encoder vs. tach velocity feedback is jumper selectable). A tachometer may be used in the velocity loop configuration to provide negative feedback to the amplifier. This allows the amplifier to close the servo loop and control the stability of the loop. - tachometer- Pin 15: Reference input for tachometer. This point is identical to signal common.
Logic Inputs	<ul style="list-style-type: none"> - ilmt-Pin 24, +ilmt-Pin 11: Directional current limit inputs (jumper selectable polarity). When "+ILMT" is pulled to its active state, motion in the positive direction (CW motor shaft rotation) is inhibited. When "-ILMT" is pulled to its active state, motion in the negative direction (CCW motor shaft rotation) is inhibited. TTL level input 0 to 5 VDC, internal pull-up, 10K input. - shutdown-Pin 10: Jumper selectable active high or active low input. Used to shut off power stage and therefore remove all power to the motor. TTL level input 0 to 5 VDC, internal pull-up, 10K input. - signal ground-Pins 7 and 14: Electrical reference for all control circuitry on amplifier. - signal shield-Pin 1: Connected internally to earth ground. Used for reducing electrical noise in control and feedback signals.
Logic Outputs	<ul style="list-style-type: none"> - fault-Pin 23: Jumper selectable active high or active low output. Used to indicate the status of the power stage (amplifier enabled or disabled). The fault output will go to its active state upon a power stage fault, thermal overload, RMS current limit, power supply under voltage condition. Open collector output. Requires pull-up resistor to external power supply ranging from +5V to +30V.
Monitor Outputs	<ul style="list-style-type: none"> - icmd-Pin 25: Current command monitor. Representative of the current command. $\pm 3V$ output.
Power Inputs	<ul style="list-style-type: none"> - AC input: AC HI , AC LO, earth ground (G [depending on model]), 115-230 VAC, 50-60 Hz, single phase.
Motor Outputs	<ul style="list-style-type: none"> - Motor - phase A, phase B, phase C.
Auxiliary Power Outputs	<ul style="list-style-type: none"> - 5V-Pin 20: On board 5V power supply. 250 mA maximum output. - 5V-Pin 2: On board 5V power supply. Pin 2 is intended for powering an encoder. Can supply up to 250mA of current.
Connectors	<ul style="list-style-type: none"> - control: 25 pin "D" style female. - power: 6 pin unpluggable screw terminal for AC input and motor output; mate provided.
Potentiometers	<ul style="list-style-type: none"> - Gain: adjusts preamp AC gain. - BALance: nulls command input DC offsets. - Tach: adjusts gain of tach or encoder derived velocity feedback input. - Input: adjusts gain of command input.

Table 3-3. Electrical Specifications (Continued)

DIP Switches	<ul style="list-style-type: none"> - Peak current limit: 4 switches allow the user to set the peak current from 6-100% of max value. - Mode switch: This switch selects current or velocity mode. - Test: This switch selects test mode to allow the BAL pot to be used as velocity or current command.
Protective Features	<ul style="list-style-type: none"> - Peak over current - RMS over current - Dynamic power dissipation limit - Over temperature - Control power supply under voltage - Power stage bias supply under voltage.
Isolation	<ul style="list-style-type: none"> - Opto and transformer isolation between control and power stages.
Indicator	<ul style="list-style-type: none"> - LED indicates drive enabled.

3.3. BAL Amplifier Dimensions

The outline dimensions for the BA amplifiers are shown in Figure 3-1.

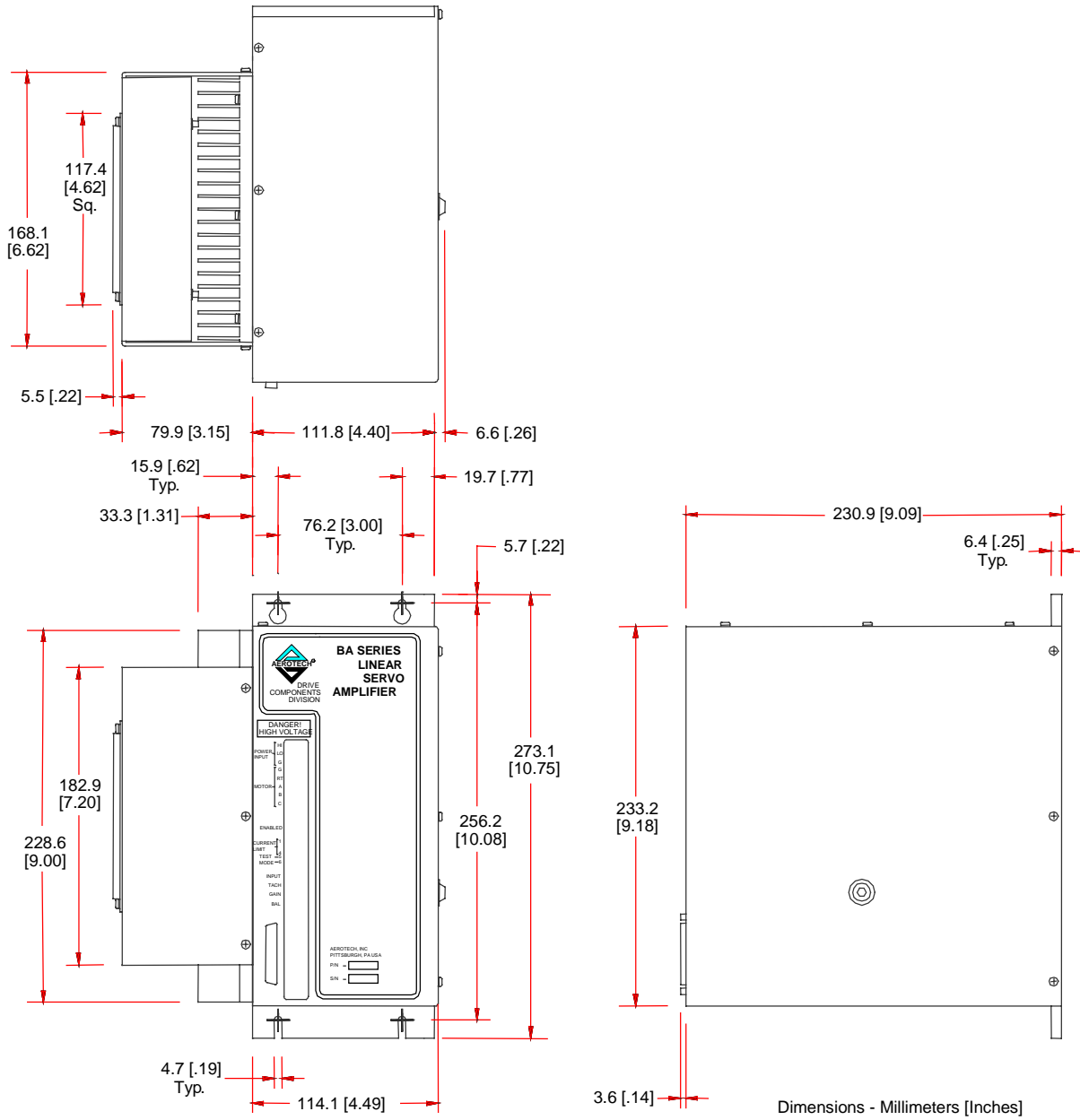

Figure 3-1. BA Linear Amplifier Dimensions



CHAPTER 4: TROUBLESHOOTING

In This Section:	
• Amplifier Related Problems	4-1

4.1. Amplifier Related Problems

This section covers symptoms, probable causes and solutions related to the BAL amplifier operation. Table 4-1 list the most common symptoms of irregular operation and the possible causes and solutions for these faults.

Before performing the tests described in Table 4-1, be aware that lethal voltages exist on the amplifier's PC board and at the input and output power connections. A qualified service technician or electrician should perform these tests.

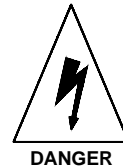

Table 4-1. Amplifier Faults, Causes, and Solutions

Symptom	Possible Cause and Solution
“ENABLE” LED fails to energize when AC input power is applied.	<ol style="list-style-type: none"> 1. Insufficient input voltage. Use volt meter to check voltages at “HI” and “LO” AC input terminals. 2. Shutdown, J6-10 is not at active state for running amplifier.
Brushless motor will not spin in open loop current mode.	<ol style="list-style-type: none"> 1. Motor phases A, B, and C connected incorrectly relative to HA, HB, and HC hall inputs. See section 2.3 for motor phasing information.
Motor spins uncontrollably in velocity mode configuration.	<ol style="list-style-type: none"> 1. Encoder (sine and cosine) signals or tach (+/-) signals are improperly connected. Swap connections to change polarity of feedback.
Motor runs erratic in velocity mode using encoder for velocity feedback.	<ol style="list-style-type: none"> 1. The phase of the sine and cosine signal of the encoder is not separated by 90°. The encoder must be adjusted on the motor. 2. Noise on the sine and cosine signals of the encoder. Use a shield or twisted pair (signal common wrapped around sine and cosine wires) cable between the motor and the BA amplifier.
Amplifier Faults (Enable LED deenergizes).	<ol style="list-style-type: none"> 1. RMS current exceeded - turn off and then back on, run at lower current. 2. Over temperature condition - Turn off and let amplifier cool down. Provide better ventilation. 3. Defective on board power supply - Return for repair. 4. Over loaded logic power supply - Remove device(s) being powered from the BAL 5 V supply.



APPENDIX A: GLOSSARY OF TERMS

In This Section:

- Description A-1

Description

The following section provides a quick reference of terms used in this manual.

CEMF - Counterelectromotive Force. Voltage generated by a motor.

DIP switch - Dual In-line Package switch. A set of tiny toggle switches built into a housing commonly used on printed circuit boards

Hall effect devices - A set of three electro-optical or magnetic switches mounted on the motor that produce a sequential pattern to provide proper motor commutation.

HED - Hall Effect Device.

RMS - Root Mean Square - The effective DC value of AC voltage or current.

TTL - Transistor - Transistor Logic.

APPENDIX B: WARRANTY AND FIELD SERVICE

In This Section:	
• Laser Products.....	B-1
• Return Procedure.....	B-1
• Returned Product Non-warranty Determination.....	B-2
• Rush Service.....	B-2
• On-site Warranty Repair	B-2
• On-site Non-warranty Repair	B-2

Aerotech, Inc. warrants its products to be free from defects caused by faulty materials or poor workmanship for a minimum period of one year from date of shipment from Aerotech. Aerotech's liability is limited to replacing, repairing or issuing credit, at its option, for any products which are returned by the original purchaser during the warranty period. Aerotech makes no warranty that its products are fit for the use or purpose to which they may be put by the buyer, whether or not such use or purpose has been disclosed to Aerotech in specifications or drawings previously or subsequently provided, or whether or not Aerotech's products are specifically designed and/or manufactured for buyer's use or purpose. Aerotech's liability or any claim for loss or damage arising out of the sale, resale or use of any of its products shall in no event exceed the selling price of the unit.

Aerotech, Inc. warrants its laser products to the original purchaser for a minimum period of one year from date of shipment. This warranty covers defects in workmanship and material and is voided for all laser power supplies, plasma tubes and laser systems subject to electrical or physical abuse, tampering (such as opening the housing or removal of the serial tag) or improper operation as determined by Aerotech. This warranty is also voided for failure to comply with Aerotech's return procedures.

Laser Products

Claims for shipment damage (evident or concealed) must be filed with the carrier by the buyer. Aerotech must be notified within (30) days of shipment of incorrect materials. No product may be returned, whether in warranty or out of warranty, without first obtaining approval from Aerotech. No credit will be given nor repairs made for products returned without such approval. Any returned product(s) must be accompanied by a return authorization number. The return authorization number may be obtained by calling an Aerotech service center. Products must be returned, prepaid, to an Aerotech service center (no C.O.D. or Collect Freight accepted). The status of any product returned later than (30) days after the issuance of a return authorization number will be subject to review.

Return Procedure

After Aerotech's examination, warranty or out-of-warranty status will be determined. If upon Aerotech's examination a warranted defect exists, then the product(s) will be repaired at no charge and shipped, prepaid, back to the buyer. If the buyer desires an air freight return, the product(s) will be shipped collect. Warranty repairs do not extend the original warranty period.

***Returned Product
Warranty Determination***

Returned Product Non-warranty Determination

After Aerotech's examination, the buyer shall be notified of the repair cost. At such time the buyer must issue a valid purchase order to cover the cost of the repair and freight, or authorize the product(s) to be shipped back as is, at the buyer's expense. Failure to obtain a purchase order number or approval within (30) days of notification will result in the product(s) being returned as is, at the buyer's expense. Repair work is warranted for (90) days from date of shipment. Replacement components are warranted for one year from date of shipment.

Rush Service

At times, the buyer may desire to expedite a repair. Regardless of warranty or out-of-warranty status, the buyer must issue a valid purchase order to cover the added rush service cost. Rush service is subject to Aerotech's approval.

On-site Warranty Repair

If an Aerotech product cannot be made functional by telephone assistance or by sending and having the customer install replacement parts, and cannot be returned to the Aerotech service center for repair, and if Aerotech determines the problem could be warranty-related, then the following policy applies:

Aerotech will provide an on-site field service representative in a reasonable amount of time, provided that the customer issues a valid purchase order to Aerotech covering all transportation and subsistence costs. For warranty field repairs, the customer will not be charged for the cost of labor and material. If service is rendered at times other than normal work periods, then special service rates apply.

If during the on-site repair it is determined the problem is not warranty related, then the terms and conditions stated in the following "On-Site Non-Warranty Repair" section apply.

On-site Non-warranty Repair

If any Aerotech product cannot be made functional by telephone assistance or purchased replacement parts, and cannot be returned to the Aerotech service center for repair, then the following field service policy applies:

Aerotech will provide an on-site field service representative in a reasonable amount of time, provided that the customer issues a valid purchase order to Aerotech covering all transportation and subsistence costs and the prevailing labor cost, including travel time, necessary to complete the repair.

Company Address

Aerotech, Inc.
101 Zeta Drive
Pittsburgh, PA 15238-2897
USA

Phone: (412) 963-7470
Fax: (412) 963-7459



APPENDIX C: CABLE DRAWINGS

In This Section:

- Description C-1

Description

The following section provides the user with 2 reference drawings for connecting Aerotech cables to the BAL amplifiers.

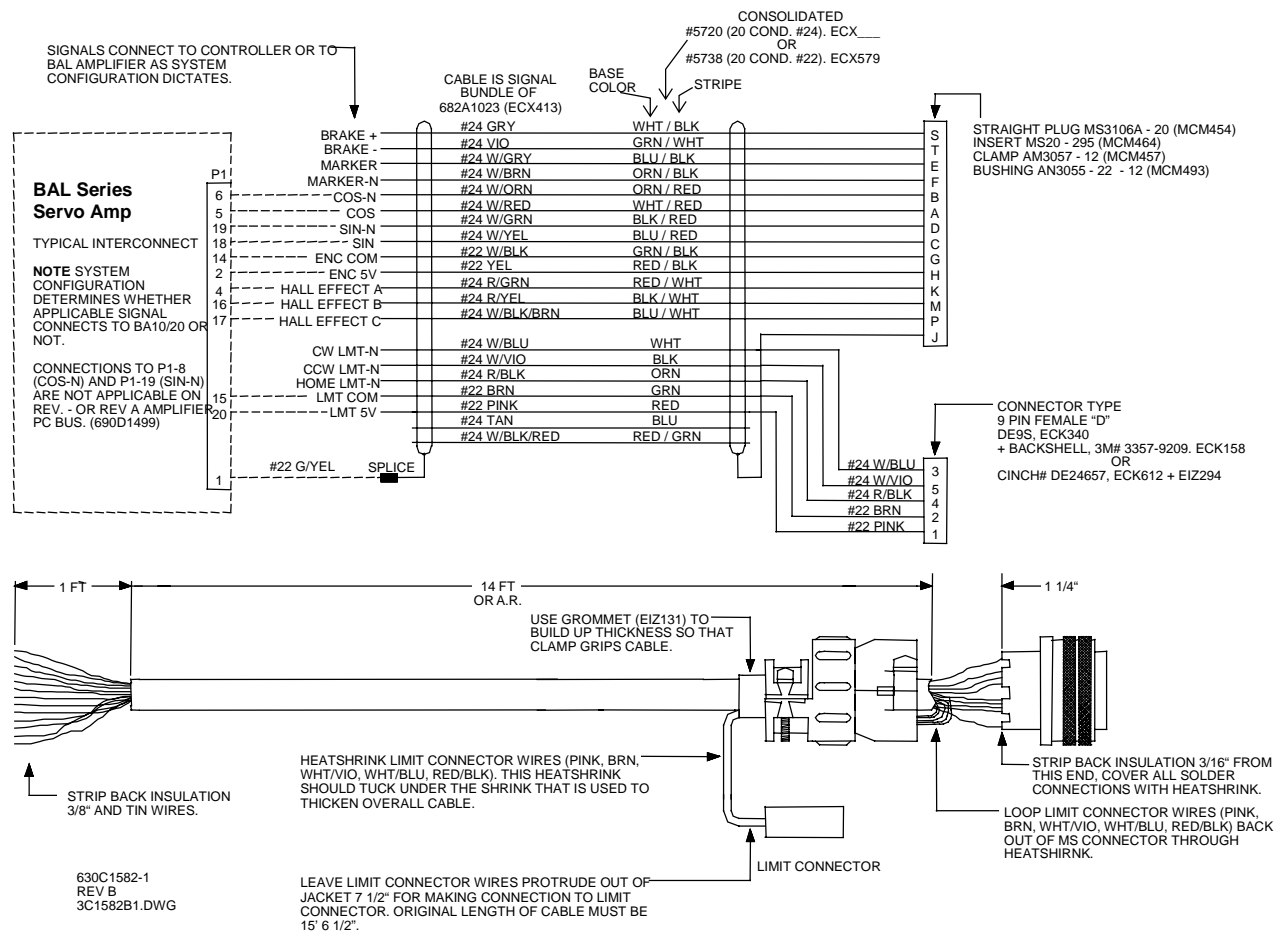

Figure C-1. BAL Feedback Cable (PFC)

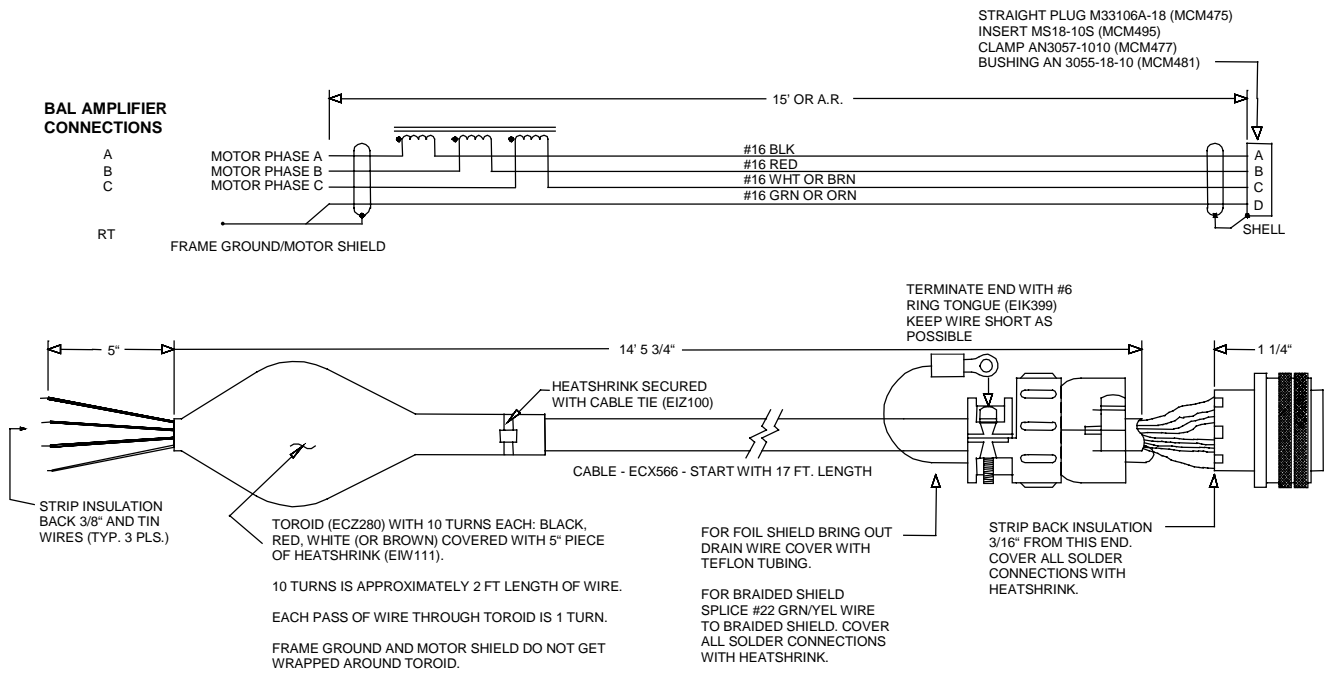

Figure C-2. BAL Light Duty Brushless Motor Cable (PMC)



-
- A**
- Amplifier faults, 4-1
 - Amplifier hardware, 1-5
 - Amplifier related problems, 4-1 applications, 1-1
- B**
- BALance pot, 1-7
 - Brush motor, 2-12
- C**
- CEMF, A-1
 - Connector, 1-5
 - Connector P1, 1-7
 - Connector pinouts, 1-8
 - Current, 1-6
 - Current Command, 2-4, 2-5
 - Current limit time-out circuit, 1-3
 - Current mode, 2-12
 - Current regulator adjustment, 2-16
- D**
- DC brush motor operation, 2-12
 - Differential Input, 2-6
 - DIP switch, 1-5, 1-6, A-1
 - DIP switch functions, 1-6
 - Drive package, 1-3
 - Dual Phase Command, 2-4, 2-6
 - Dual phase command mode, 2-11
- E**
- Electrical specifications, 3-2
 - ENABLE LED, 1-7
 - Encoder, 2-4
 - Encoders, 1-2
 - External Controller, 2-4
- F**
- Fault conditions, 1-2
 - feedback signals, 1-2
 - Field Service Policy, B-1
 - Functional diagram, 1-4
- G**
- GAIN pot, 1-7
- H**
- Hall effect device, 1-2, A-1
 - Hardware function, 1-5
 - Hardware overview, 1-5
- I**
- INPUT pot, 1-7
 - Installation, 2-1
 - Integrated, 2-4
 - Integrated Configurations, 2-4
- J**
- Jumper selections, 2-1
- L**
- LED indicator, 1-5
- M**
- Mechanical drawings, 3-5
 - Mode, 1-7
 - Models, 1-2
 - Motor, 2-15
 - Motor phasing, 2-14
 - Multiple brush motor, 2-13
- O**
- Operating modes, 1-2
 - Options, 1-2
 - Order information, 3-1
- P**
- Part number information, 3-1
 - Phase Hall sequence, 2-14
 - Position, 2-5
 - Potentiometer functions, 1-7
 - Potentiometers, 1-5, 1-7
 - Power amplifiers, 1-3
 - Power and control connections, 2-8
 - Power connections, 1-5
 - Power limit circuit, 1-3
 - Pre-Amplifier Circuit, 2-6
 - Precautions, 1-12
 - Product Overview, 1-1
- R**
- Revision History, R-1

RMS, A-1

S

Safety Procedures, 1-12
Self-Commutation, 2-6
Single brush motor, 2-12
Six wire connections, 2-7

T

TACH pot, 1-7
Tachometer, 2-4
Test, 1-6
Torque command mode, 2-8
Troubleshooting, 4-1
TTL, A-1

U

Unconnected phases, 2-7

V

Velocity, 1-6, 2-4
Velocity Command, 2-4
Velocity command mode, 2-9
Velocity mode, 2-12
Voltage configurations, 1-2

W

Warnings, 1-12
Warranty Policy, B-1

▽ ▽ ▽

REVISION HISTORY

<p>In This Section:</p> <ul style="list-style-type: none"> Revisions R-1
--

Revisions

The following section provides the user with general information regarding the latest changes to this manual. Extensive changes, if made, may not be itemized – instead, the section or chapter will be listed with “extensive changes” in the corresponding General Information cell.

Table R-1. Revisions

Revision	Section(s) Affected	General Information
1.5	1.4.5.	Figures 1-4 through 1-7: text changes (P1-n should have been P6-n)
	2.2.	Table 2-1.: jumper 11 setting changed from 3-4 to 2-3
		Figure 2-1: J8 mislabeled as J6.
	2.5.2.	Figure 2-6. updated: text changed P1-n should have been P6-n.
	2.6.2.	Text changed: JP3 set to 2-3.
3.2.	Table 3-3. text added: Minimum Load Resistance (line-to-neutral)	
1.4	1.4.2.	Page 1-6: DIP Switch setting reversed (Open setting was noted as Closed and vice versa in graphic next to Table 1-2).
1.3a	2.5.1., 2.5.2	SW1 changed to SW4





READER'S COMMENTS

BA Linear Series User's Manual P/N EDA 139, May 2002

Please answer the questions below and add any suggestions for improving this document. Is the information:

	Yes	No
Adequate to the subject?	___	___
Well organized?	___	___
Clearly presented?	___	___
Well illustrated?	___	___
Would you like to see more illustrations?	___	___
Would you like to see more text?	___	___

How do you use this document in your job? Does it meet your needs?
What improvements, if any, would you like to see? Please be specific or cite examples.

Your name _____
Your title _____
Company name _____
Address _____

Remove this page from the document and fax or mail your comments to the technical writing department of Aerotech.

AEROTECH, INC.
Technical Writing Department
101 Zeta Drive
Pittsburgh, PA. 15238-2897 U.S.A.
Fax number (412) 967-6870

