

Bell System (Telephones) Ltd.

bell*free*

1 Way

Video Door Entry System

With

Hands-free Colour Apartment Stations

Installation & Operation Manual

This manual applies to the following: -

BFD1 Way Door controller – Version 1 Builds 1

BF Colour Apartment Station – Version 1 Build 1

BS Colour Videophone – Version 2 Builds 1 to 3

BSA Audio Phone – Version 1 Build 1

BF Apartment Station 1 Way System



bell*free* Apartment Station



BFD1 controller



BSA audiophone



BS videophone



BS Deskphone

TABLE OF CONTENTS

TABLE OF CONTENTS	3
INTRODUCTION	4
DESCRIPTION	4
MAIN FEATURES	4
BASIC SYSTEM OPERATION	6
DESIGN CONSIDERATIONS	9
EQUIPMENT LIST.....	9
OPTIONS.....	9
POWER SUPPLY REQUIREMENTS	10
CABLE SPECIFICATION.	11
CABLE DISTANCES.....	12
INSTALLATION & COMMISSIONING	13
CHECKLIST.....	13
WIRING.....	13
COMMISSIONING	17
BFD1 DOOR CONTROLLER SWITCH SETTINGS.....	18
BFD1 DOOR CONTROLLER JUMPER SETTINGS	21
DOOR SPEECH VOLUME ADJUSTMENT.....	22
BF APARTMENT STATION SWITCH SETTINGS	23
BS VIDEOPHONE SWITCH SETTINGS	24
TROUBLESHOOTING	25
COMMON FAULTS	25
QUICK FAULT REFERENCE.....	25
SPECIFICATIONS	28
DIAGRAM A – 1 WAY BASIC SYSTEM WIRING OVERVIEW	30
DIAGRAM B – 1 WAY PCB DETAIL	31
DIAGRAM C – 1 WAY BASIC SYSTEM WIRING DETAIL	32
DIAGRAM D – 1 WAY MULTIPLE ENTRANCE WIRING OVERVIEW	33
DIAGRAM E – 1 WAY MULTIPLE ENTRANCE WIRING DETAIL	34
DIAGRAM F – EXTENSION APARTMENT STATION WIRING	35
DIAGRAM G – APARTMENT STATION LOCAL POWER WIRING	36
DIAGRAM H – CAMERA SHARING & TIME CLOCK SHARING	37
DIAGRAM I – 1 WAY DDA PANEL WIRING	38
DIAGRAM J – COMBINED CONNECTIONS BELL <i>FREE</i> WITH LOCK	39
DIAGRAM K – COMBINED CONNECTIONS THIRD PARTY LOCK	41
SAFETY INFORMATION AND DECLARATIONS	43

Introduction

Description

A *bellfree* video door entry system consists of a door panel, positioned at the entrance of a building, video apartment station(s), placed inside of the building for the convenience of the occupants and a power supply and controller which are usually located inside an electrical cupboard. The door panel comprises of a two-way speech unit, a camera and a push button – which must be depressed by a visitor to initiate a call. The apartment station, which rings in response, allows a two-way hands free conversation (a touch is required to initiate the conversation and end the conversation) whilst the caller can be observed through the integral display. The operator can selectively allow visitors access to the building by touching a pad on the apartment station and so electrically releasing the door.

The *bellfree* 1-way Video Door Entry System is suitable for any building requiring a single push button at the entrance, such as houses, individual flats and offices. For multi-way systems please refer to either the “*bellfree* 2-72-way Video Entry System” or “*bellfree* Digital Video Entry System” manuals.

The *bellfree* “1-way” system is supplied with a dedicated door controller, which has been specifically optimised for “1-way” systems, ensuring simple installation. This basic system can support up to 3 extension apartment stations (more with additional power supplies). Multiple entrances can be supported with the addition of one panel and one door controller for each entrance.

Main Features

- Enhanced audio for hands free operation
- Cat5 cable throughout; no co-ax required!
- 3.5” Flat screen high resolution TFT colour display.
- High resolution CCD colour day/night camera with infrared lamps.
- 12V d.c. operation
- High quality full-duplex speech amplifier.
- Automatic picture display while ringing.
- Operator activated picture (CCTV mode)
- Ringer mute function.
- Ringer volume control.
- Fail safe or fail secure lock releases and magnetic locks (maglock).
- Lock release timer.
- Tradesman facility (optional).
- Facility for exit button and/or fire switch.
- Door open indication.
- Second camera option.
- Up to 3 extension Apartment stations per flat.
- DDA panel options.
- Multiple entrances supported.

BF Apartment Station 1 Way System

bell free Colour Apartment Station

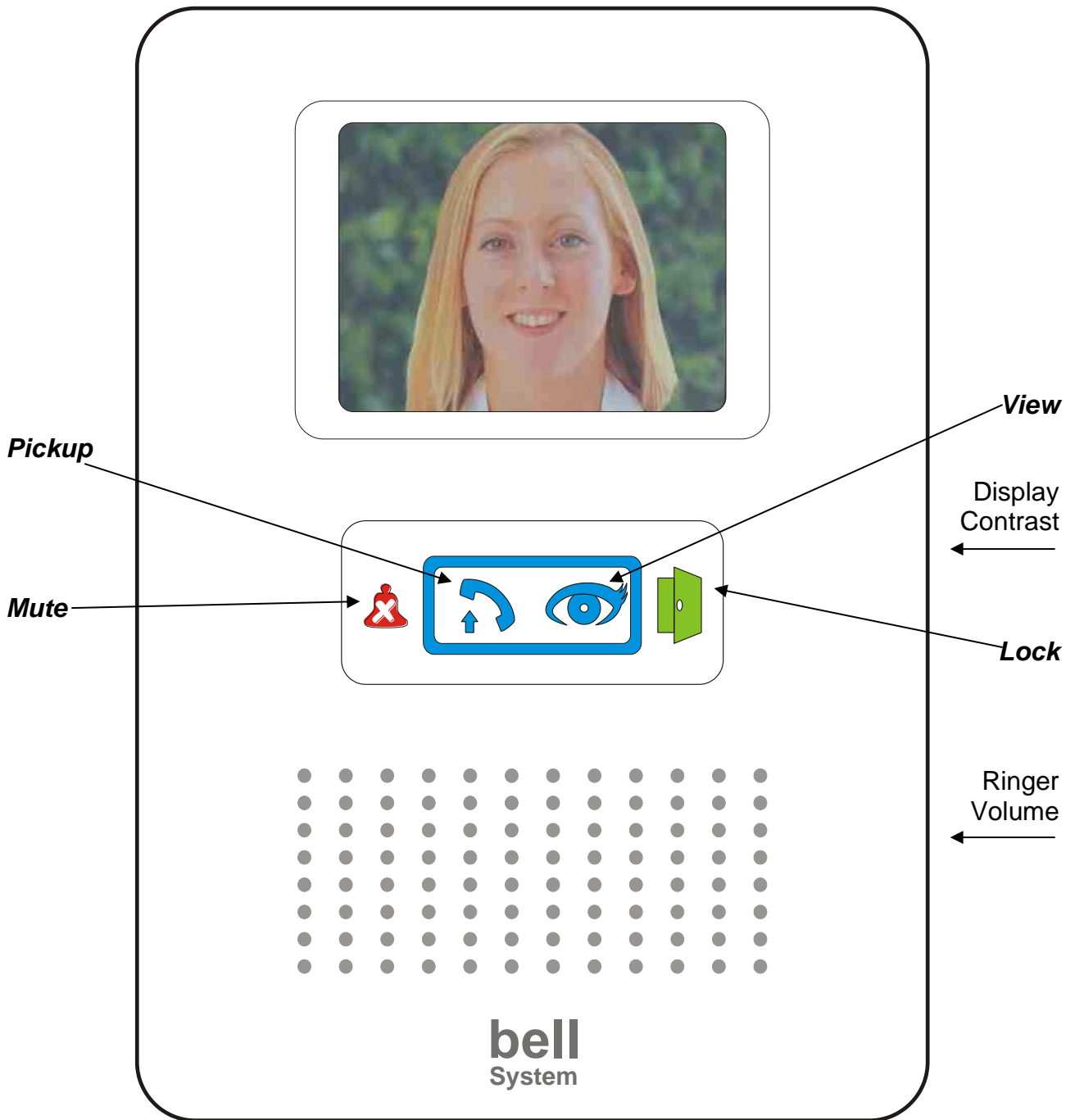

Symbol	Lamp	Steady	Flashing
Mute on/off	Red	Apartment station is muted	
Pickup / end	Blue	Call in progress	Ringing
View / camera select			
Lock	Green	Door is open	Touch to release lock
All symbols	All		Doorbell

Basic System Operation

Call sequence

When the **call** button is pressed at the entrance panel the apartment station will ring and its blue **pickup / view** lamp will flash, highlighting the **pickup** and **view** symbols. The apartment station will continue to ring for up to 30 seconds or until the resident responds by touching the **view** symbol (see silent viewing below) or the **pickup** symbol. After using the **pickup** symbol the resident can freely converse with the visitor whose image is now displayed on the apartment station; at the same time the green **lock** symbol will flash to highlight the **lock** function.

The call may be terminated by touching the **pickup** symbol again or more usually by touching the **lock** symbol first to allow the visitor access through the entrance; the speech and picture will persist for a further 3 seconds while the door is being released.

Silent viewing

When the apartment station is ringing the resident can touch the **view** symbol to answer the call instead of the **pickup** symbol; this will stop the apartment station ringing and enable them to view the visitor for up to 60 seconds or until the **lock** symbol is touched to release the door. Silent viewing can be 'normalised' at any time by touching the **pickup** symbol and conversing with the visitor as described above.

Apartment Station Controls

The diagram in the introduction shows the apartment station and its controls. The controls are adjusted by touching the end of the slider and sliding the finger up and down. The default setting is ringer volume halfway and contrast slider fully down.

Auto Display

When 'Auto Display' mode is selected the picture will come on while the apartment station is ringing, otherwise the picture will only come on when the call is answered. Auto Display mode is usually pre-selected at installation and generally only one apartment station should be set in this mode (see 'Extension Apartment Stations' below).

Ringer Mute

The resident can mute the ringing sound in the apartment station when they do not wish to be disturbed. Ringer mute is activated by touching the **mute** symbol on the apartment station, which then illuminates in red as a reminder. Touching the **mute** symbol a second time will disengage the mute function. Ringer Mute only stops the audible ring, but the blue ring lamp will still flash and all other functions work normally. Ringer mute will continue for the pre-set time even if a call is answered.

During installation it is possible to set a time limit for the mute function in various values from 2 minutes up to 10 hours or indefinitely. When this time period has elapsed the mute function will automatically disengage. Default timeout is never (See 'mute timer', page 2324).

Door Status Indication

The green **lock** lamp on the apartment station will illuminate to warn the resident that a door has been left open following a call. This feature requires a door monitor contact to be fitted.

BF Apartment Station 1 Way System

Call Privacy

Once a call has been made from an entrance panel only the apartment station(s) which is / are ringing may answer the call. Once the call is answered another apartment station will not activate (including extensions of the active apartment station).

User Activation (CCTV Mode)

While the system is idle, touching the **view** symbol will activate the system and display the picture at the primary entrance panel. Once activated, touching the **pickup** symbol will enable speech at the entrance and the lock symbol may now be used to release the door or the user can hang-up. The picture will switch off after the pre-set talk-time.

Cameras

The door controller has the capability of using one or two cameras, for instance a second panel camera for DDA or a 'third party' 'CCTV' camera located to offer a different entrance viewpoint. Touching the **view** symbol will alternate the view between camera 1 and camera 2 (if enabled).

Note. The camera to controller wiring has termination options which allow for connections to other video equipment. See the Camera sharing diagram on page 37 for details.

Extension Apartment Stations

Additional apartment stations may be added to the basic system. The number of extensions is limited only by power supply considerations. All apartment stations will ring when called however typically only the master unit will display a picture while ringing. Once the master or extension apartment station is 'picked-up' the picture will display on that unit alone. An extra power supply may be used to allow extension apartment stations to display a picture while ringing.

Lock Type

The door controller supports both fail-secure and fail-safe locks including magnetic locks of up to 1A rating. The lock time may be programmed between 1 and 99 seconds. (See 'Lock Operating time' and 'Lock Type' on page 19.

Exit Button and Fire Switch

An input is provided for an exit button, which can be installed on the inside of the door and allow residents to exit freely. Momentary operation of this button will operate the lock release for the programmed lock time. A Fire switch or other override device may use the same input to hold the door open indefinitely. Note. Fail secure locks must be continuously rated.

Trades Facility

Use of a time clock in conjunction with a trades button will allow free access during the programmed time(s).

DDA Functionality

The bellfree video system has a range of options for entrance panels to help meet the requirements of the Disability Discrimination Act (DDA), including Illuminated Tactile buttons, reassurance tones and LED indicators for "Speak Now" and "Door Open". Contact your sales representative for further details.

Reassurance tone setting is on page 21.

BF Apartment Station 1 Way System

Multiple Entrances

The bellfree system allows multiple entrances to be catered for by the addition of a door controller and entrance panel for each entrance and additional power supplies.

In a multiple entrance system an optional feature allows the resident to view the cameras at all the entrances with successive touches of the **view** symbol.

For details of this camera feature and user activation see the setting for 'Camera Numbering' on page 20.

Design Considerations

Equipment List

A BF1 one-way bellfree Video Kit comprises the following: -

Model No	Description
1 x BF	Colour apartment station
1 x BFP1	Vandal resistant panel with a BF-AMP speech unit, VR buttons and camera.
1 x BFD1	Door controller.
1 x PS4	4A 12V power supply.
1 x 203	Fail-secure lock release, alternate types available

Options

The following options are available: -

- Extensions using model **BF** apartment station(s).
- Extensions using Videophone model **BS**.
- Extensions using Audio only phones model **BSA**.
- Additional entrances, each comprising a **BFD1** controller and **BFP1** panel. (See also power supply requirements).
- Alternative lock releases, fail-safe and fail-secure.
- Timed Trades facility; specify **TRBS** to add another button and a **TS2000-BST** time-clock. The extra button will be engraved "TRADES"
- Exit button. Model **5077** surface and model **5078** flush versions are available.
- Battery back-up power supply, **Model 840** (12V 4A).
- DDA panels (Contact sales for further information).

Entrance Panel – Important Note

Careful consideration should be given to the location of the entrance panel to ensure the best possible lighting conditions for the camera. In general strong back lighting of the subject (by the sun and sky) should be avoided, as the contrast between foreground and background may be too great for the camera. The field of view should contain as little of the sky as possible, particularly if south facing. If a backlit situation is unavoidable, additional lighting may be necessary to illuminate the caller and avoid a dark outline image (silhouette). A light coloured or reflective surface around the panel will redirect backlight to illuminate the caller.

Door Controller

The door controller and power supply should be wall-mounted in a convenient cupboard or other protected environment with available mains power. Cable length to the entrance should be less than 50m. The door controller for the second and subsequent entrances may be situated in the same location, or to meet the 50m requirement may be situated in another location. Power supplies may be shared between door controllers placed in the same location, but controllers in separate locations must be separately powered.

Separately Powered Apartment Stations

The limitation of up to 4 apartment stations ringing but only one displaying, as indicated in the power supply and cable distance tables on page12, can be overcome by the use of supplementary power from a 340C.

BF Apartment Station 1 Way System

Power Supply Requirements

The system is powered by 12V power supplies only: -

Model PS4 12V, 4A.

Model 840 12V, 4A battery backup supply.

Model 340C 12V, 1.5A optional for extensions.

Note 1. The 28V referred to on the apartment station, video controller and wiring diagrams is internally generated in the controller. DO NOT use any power supply other than 12V or damage may occur.

Note 2. The PS4 power supply has been specifically designed to operate with the high-surge requirements of the system. Bell System is unable to guarantee functionality or provide support for systems which use third party power supplies.

Exact power supply requirements depend upon many factors. The number of power supplies included within a standard 'kit' or quotation assumes that all controllers are installed in one location and that there are no extensions.

The following table gives examples of the controllers and power supplies for a given number of entrance doors and extensions.

System	Controllers and Power Supplies
1 door and 1 apartment station (standard kit)	1 x BFD1 door controller 1 x PS4 12V 4A power supply
2 doors and 1 apartment station	2 x BFD1 door controller 1 x PS4 12V 4A power supply
3 doors and 1 apartment station	3 x BFD1 door controller 2 x PS4 12V 4A power supply
Up to 3 extension apartment stations not displaying picture during ring	No extra power supplies required
Any number of extension apartment stations displaying picture during ring	1 x 340C 12V 1.5A power supply per extension apartment station
2 doors and 6 apartment stations all to display picture during ring	2 x BFD1 door controller 1 x PS4 12V 4A power supply 5 x 340C 12V 1.5A power supply

Cable Specification.

All system wiring must be carried out using **Cat5** signal cable and where necessary 1mm² (or greater) power cable as tabulated below. Cat5 cable has a known performance for the transmission of video signals, whilst telephone or alarm cables are not suitable.

Bell System will be unable to offer any warranty or support for systems installed using incorrect cables.

Cat5 Cable Specification

Cat5 is our short reference for EIA standard UTP Category 5 Unshielded Twisted Pair data cable. This is a standard solid core twisted pair cable having 4 pairs (8-cores) and no shield. The cores are in pairs where Blue and 'Blue with a White stripe' are twisted together as the first pair. The other three pairs are similar with main colours Orange, Green and Brown.

- Also available and acceptable are:

UTP Category 5e (Cat5e)

UTP Category 6 (CAT6)

UTP Category 6e (CAT6e)

The exact cable can be chosen from the above on cost and availability grounds.

- STP (Shielded Twisted Pair) cables are **not** recommended.
- UTP "patch cables" are **not** recommended.

NOTE: Cat5 cable is easily identifiable as the specification is printed on the sheath

BF Apartment Station 1 Way System

Cable Distances

Door Controller to BF Apartment Station			
System	Distance	Cable	Comments
Single apartment station per output or first apartment station	< 150m	1 x Cat5	
	< 300m	1 x Cat5 2 x 1mm ²	
Single apartment station + 3 extensions on each output, all cable powered	< 50m	1 x Cat5	Only Master apartment station has 'Auto display'; extensions are daisy-chained
	< 200m	1 x Cat5 2 x 1mm ²	
Single apartment station per output with separately powered extensions	< 150m	1 x Cat5	150m maximum to the cable powered apartment station; daisy-chain up to 300m total.
	< 300m	1 x Cat5 2 x 1mm ²	
All apartment stations locally powered with a 340C power supply	< 300m	1 x Cat5	Locally powered apartment stations have 'Auto display'; extensions are daisy-chained
	<25m to 340C	1 x pair of Cat5	
	<100m to 340C	2 x 1mm ²	

Entrance to Door Controller			
Connection	Distance	Cable	Comments
Entrance Panel	<50m	7 x pair of Cat5	See page 30 for details.
Lock Release up to 1A	<10m	1 x pair of Cat5	
	<50m	2 x 1mm ²	
Option: Exit button	<50m	1 x pair of Cat5	
Option: Trades button	<50m	1 x pair of Cat5	Requires a Time-clock
Option: Door Monitor Switch	<50m	1 x pair of Cat5	
Option: Second Camera / Dual Height	<50m	3 x pair of Cat5	Extra camera and button.

Power Supply to Controller			
System	Distance	Cable	Comments
All Systems, each PS4 to BFD1	<3m	2 x 1mm ²	
	<5m	2 x 1.5mm ²	

NB. A Cat5 cable has 4-pairs (8 cores)

For larger cable distances please contact manufacturer.

Installation & Commissioning

Checklist

The following checklist is a summary of what is required. Refer to the relevant pages for further details.

- Review the section headed 'Safety Information' on page 43.
- Ensure that 'Design Considerations' on page 9 have been understood.
- Confirm that Cat5 cable has been specified.
- Install the system according to instructions in this section.
- Check/set the door controller jumper and switch settings.
- Check/set each apartment station dip-switch settings.

Wiring

Refer to the diagrams from page 30 onwards as appropriate for the equipment you have.

All wiring is carried out using a mixture of Cat5 for the signal wiring and 1mm² (or greater) cores for the power wiring; refer to Page 11 for further details. It is strongly recommended that a consistent colour code be used throughout such as that indicated on the connection diagram. Certain signals must be interconnected using a twisted pair from the Cat5 cable. These are clearly marked on the connection diagram and should be strictly observed.

Entrance Panel

The panel should be mounted at an optimum height of 1.6 m, measured between the ground and the centre of the camera window. DDA considerations may reduce this height to 1.4m. With flush mounting panels it is advisable to apply mastic to the top and side edges of the panel to prevent water ingress behind the panel, but not to the bottom edge. On construction sites the panel must be protected from corrosive substances such as 'brick acid'. The panel should be cleaned only with a damp cloth containing dilute detergent.

BF Apartment Station 1 Way System

Apartment Station

The apartment station is designed to be surface or flush wall mounted onto plasterboard or other masonry at an optimum screen height of 1.6m. DDA considerations may reduce this height to 1.4m. Dimensions are shown in the diagrams below.

Surface Mounting

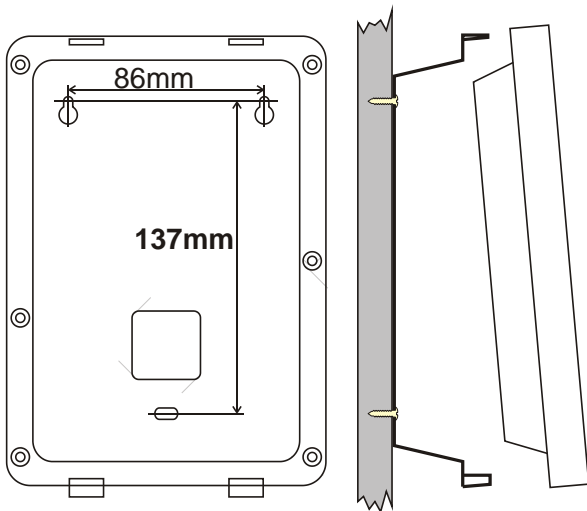

Mounting requires three No 8 screws (not supplied) and wall plugs may also be needed for a secure fixing.

Flush Mounting

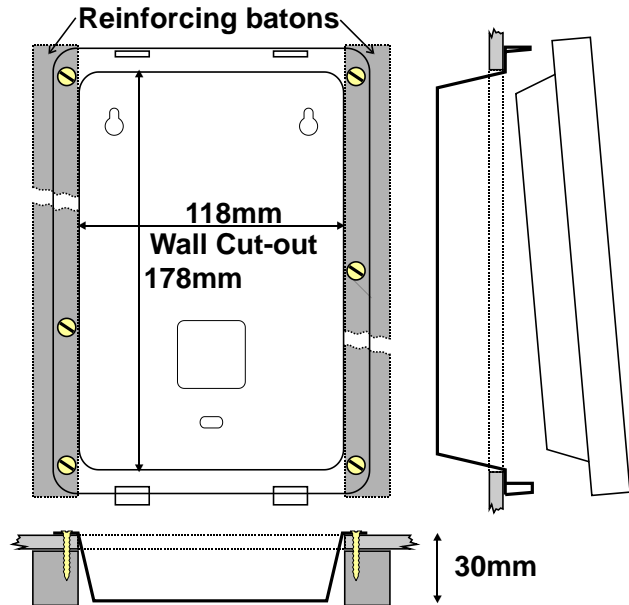

Flush fixing requires a hole in the plasterboard reinforced with batons to give a solid fixing for the four or six No 8 screws.

The reinforcing batons are longer than the cut-out, so they may need to be split to allow insertion.

The apartment station unit is removed from the wall mounting box by pushing in the two circular buttons at the bottom and pulling apart, once open far enough the two hanging clips will release/lift off.

Replace the apartment station unit by hanging it on to the two hooks at the top of the wall mounting box and then push the bottom of the unit onto the two sprung clips.

Top, bottom and rear cable entry alternatives are available in the wall mounting box.

The Video terminator and dip-switch options are available from the back of the removable unit.

The video terminator jumper is next to the removable 10 way connector block. Dip-switch settings are summarised on the adjacent label (see also Page 23).

Doorbell

The apartment station has a doorbell function which is activated by the closure of a normally open contact. This would typically be from a non-illuminated door push.

BF Apartment Station 1 Way System

BSA Audio Phone

The BSA audio phone can be used as a lower cost alternative to an extension apartment station. It is styled like the *bellissimo* videophone. The phone is manufactured in high-impact ABS plastic that imparts high durability and compliments most wall furnishings. It incorporates both ***mute*** and ***lock*** illuminated buttons and it has an Electronic Ringing Tone with an internal rotary pre-set volume control.

Remove the top cover of the BSA phone, which is secured by clips at both sides, by using both hands and placing fingers under the edges and using thumb pressure to release the clips.

The BSA audio phone should be fixed with two No 8 screws (not supplied).

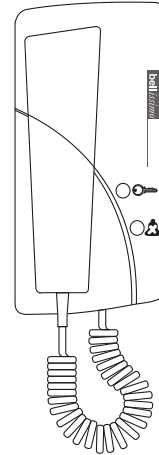

Videophone (Alternative to Apartment Station)

The videophone is designed to be wall mounted onto plasterboard or other masonry at an optimum height of 1.6m. It should be fixed with three No 8 pan head screws (not supplied). Use the dimensions shown on the adjacent diagram. If the cable is to be fed from the wall cavity then make a hole for this at the same time, the surface cable exit is to the left of the cut-out. The top two screws are hidden fixings, so screw in but do not fully tighten. Test hang the videophone and adjust the screws as required.

Now remove the top cover of the videophone, which is secured by a clip at the bottom. Hang the videophone on the two screws already fitted allowing the cable (if present) to feed through and the third screw to be inserted at the bottom. Tighten the third screw.

If the silicone rubber buttons fall out, clip them back into the PCB. Before replacing the Front Cover remove the protective film from the display lens and also check that the DipSwitch settings are correct or change as necessary (see Page **Error! Bookmark not defined.**).

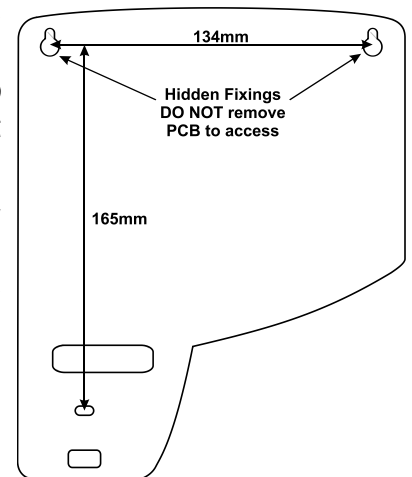

BF Apartment Station 1 Way System

Electric Door Release

Both fail-secure and fail-safe lock releases (including magnetic locks) use the same terminals. To set the lock type, refer to the “Door Controller Settings”. When installing lock releases please allow a little movement on the door, as operation will be impaired if fitted too tight.

NB. Magnetic locks (maglocks) must be fitted with a suppressor at the lock terminals. Some manufacturers fit an acceptable internal suppressor.

Fail Safe Exit: Notes

Fail safe exits using maglocks require an exit button and this should be normally open so that the controller can be used to give a timed exit. If the exit button has both normally open and normally closed contacts, then the normally closed contact can be wired in series with the release or maglock along with the break glass in case of equipment failure.

A not uncommon problem with maglocks, because they cannot be mechanically overridden, is being locked out of the building due to lost codes, fobs or equipment failure. So consider an alternate building entrance, or an externally accessible secure keyswitch, or a reliable method of disabling the system during overnight secure lockup.

Fail Secure Exit: Notes

Commonly fail secure exit doors incorporate a thumb-turn, door handle or mini push bar rather than use of an exit button. Fire officers usually require a minimum of door handle or push bar to open a door on a fire exit route – not a thumb-turn.

Most fail secure locks are not continuously rated and if an electrical hold open system is used for say busy times, then a continuously rated release must be used.

Powered bolt, shoot-bolt or other more secure door locking systems may require the use of separate power supplies or a suppressor to be fitted. Shoot-bolt systems for instance tend to require at least 1.5A peak current and this will require the use of an isolation relay and a separate power supply for the lock.

Exit Button Input

The exit button is used to unlock the door for the pre-set lock operating time. The input is designed only for use with a normally open push button. ‘Exit +’ is the input and ‘Exit -’ is internally connected to 0V.

The ‘Exit +’ input can also be used for connection to other equipment to open the door as shown in Diagram J – Combined Connections *bellfree* With Lock.

Door Open Switch

The door open switch is used to provide an indication at the apartment station that the door has been left open. This switch can have closed contacts when the door is closed or open contacts when the door is closed, the choice being made in Panel Programming. The default of ‘contacts open when door closed’ must be selected when this feature is not required.

Time Clock Sharing

In a large system a single time clock can be shared between distributed equipment areas by borrowing one of the ‘comm -’ wires in the interconnecting Cat5 to use as the shared “Time clock common”. See the detailed diagram on page 37.

BF Apartment Station 1 Way System

Commissioning

The major components of the bellfree Video system are fitted with high quality pluggable screw terminal blocks. This enables all the connections to the system to be fully completed, whilst easily isolating individual pieces of equipment during testing and commissioning.

When powering up for the first time, it is highly recommended that only the most basic system be connected. i.e. 1 BF apartment station, 1 door controller and panel, and 1 video controller; the remaining equipment can be isolated by unplugging terminal blocks.

Proceed to test the system by calling the apartment station from the door panel in the usual way. Any problems can be resolved by rechecking wiring and connections, assisted by the various suggestions and tests in the section "Troubleshooting". Once the basic system is fully functioning, continue to reconnect and test the remaining equipment item by item until completed.

BFD1 Door Controller Switch Settings

Talking Time/Apartment station Active DIP SW1 (1-4)

4	3	2	1	Talk Time
On	On	On	On	15s
On	On	On	Off	20s
On	On	Off	On	30s
On	On	Off	Off	45s
On	Off	On	On	60s
On	Off	On	Off	75s
On	Off	Off	On	90s
On	Off	Off	Off	120s
Off	On	On	On	150s
Off	On	On	Off	180s
Other settings				60s
Off	Off	Off	Off	60s*

*Default setting

SW1 SW2 SW3

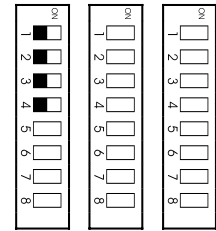

OFF ↔ ON

Ring Time/Call Time and Ring Effect DIP SW1 (5-8)

8	7	6	5	Call Time	Ring Cadence or Sound Effect
On	On	On	On	5s	1 in 3 – 1 ring every 3 seconds
On	On	On	Off	8s	1 in 3 – 1 ring every 3 seconds
On	On	Off	On	10s	1 in 3 – 1 ring every 3 seconds
On	On	Off	Off	15s	1 in 3 – 1 ring every 3 seconds
On	Off	On	On	20s	1 in 3 – 1 ring every 3 seconds
On	Off	On	Off	30s	1 in 3 – 1 ring every 3 seconds
On	Off	Off	On	40s	1 in 3 – 1 ring every 3 seconds
On	Off	Off	Off	45s	1 in 3 – 1 ring every 3 seconds
Off	On	On	On	50s	1 in 3 – 1 ring every 3 seconds
Off	On	On	Off	60s	1 in 3 – 1 ring every 3 seconds
Off	On	Off	On	30s	1 in 3 (Reserved For future use)
Off	On	Off	Off	30s	1 in 3 (Reserved For future use)
Off	Off	On	On	30s	2 in 15 – 2 rings, 15S silence, repeat
Off	Off	On	Off	30s	1 in 15 – 1 ring, 15S silence, repeat
Off	Off	Off	On	30s	1 in 5 – 1 ring every 5 seconds
Off	Off	Off	Off	30s*	1 in 3* – 1 ring every 3 seconds

*Default setting

SW1 SW2 SW3

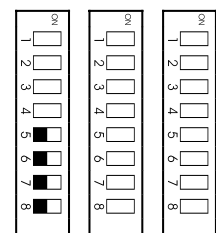

OFF ↔ ON

BF Apartment Station 1 Way System

Lock Operate Time Dip SW2 (1-3)

3	2	1	Lock Time
On	On	On	3s*
On	On	Off	4s
On	Off	On	5s
On	Off	Off	6s
Off	On	On	8s
Off	On	Off	10s
Off	Off	On	15s
Off	Off	Off	20s

*Default setting

SW1 SW2 SW3

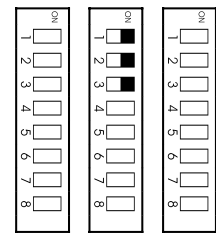

OFF ↔ ON

Individual Functions DIP SW2 (4-8)

SW1 SW2 SW3

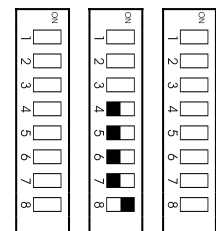

OFF ↔ ON

SW2-4	Lock Type	Lock behaviour during power failure
*Off	Fail secure lock	Requires alternate mechanical means, key or thumb-turn to open on power failure
On	Fail safe lock	Lock opens on power failure
SW2-5	Door Status Switch	Monitors doors left open
*Off	Contacts Open when Door is Closed	The default allows for no switch fitted
On	Contacts Closed when Door is Closed	Standard normally closed switch
SW2-6	Camera 2	How many cameras at this door
*Off	Camera 1 only	Default – single camera per door
On	Enable Camera 2	Second camera at the door
SW2-7	View Function	Camera action when view symbol touched
*Off	Local View	View symbol only selects the camera(s) at this door
On	Global View (See DIP SW3 below)	View symbol sequentially selects all cameras at doors with this switch set
SW2-8	CCTV Mode	View symbol touched when system is idle
Off	Disabled	View symbol only works when called from the panel
*On	Enabled See notes below	User can activate the system and look to see anyone near the door(s)

*Default setting

BF Apartment Station 1 Way System

Camera Numbering DIP SW3 (1-8)

Camera 1 at this door				
4	3	2	1	Number
On	On	On	On	*1
On	On	On	Off	2
On	On	Off	On	3
On	On	Off	Off	4
On	Off	On	On	5
On	Off	On	Off	6
On	Off	Off	On	7
On	Off	Off	Off	8
Off	On	On	On	9
Off	On	On	Off	10
Off	On	Off	On	11
Off	On	Off	Off	12
Off	Off	On	On	13
Off	Off	On	Off	14
Off	Off	Off	On	15
Off	Off	Off	Off	16

Last Camera				
8	7	6	5	Number
On	On	On	On	*1
On	On	On	Off	2
On	On	Off	On	3
On	On	Off	Off	4
On	Off	On	On	5
On	Off	On	Off	6
On	Off	Off	On	7
On	Off	Off	Off	8
Off	On	On	On	9
Off	On	On	Off	10
Off	On	Off	On	11
Off	On	Off	Off	12
Off	Off	On	On	13
Off	Off	On	Off	14
Off	Off	Off	On	15
Off	Off	Off	Off	16

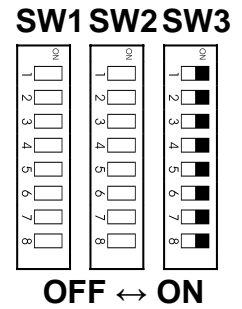

*Default setting

View Activated by User (CCTV mode)

The 'CCTV Mode' (SW2-8) setting must only be enabled at one door. Camera 1 at this entrance will then be the first camera to be viewed.

'Global View' at Multiple Entrances

If 'Global View' is enabled, successive touches of the view symbol will enable all entrance to be viewed in turn, including any second cameras, if enabled.

Setting up the door controllers to enable 'Global View' requires careful setting of the switches. Not all entrances have to participate in 'Global View', and these entrances should remain set to 'Local View'.

For the participating entrances number the cameras 1, 2, 3, ...etc. It is recommended that the entrance selected for CCTV is also numbered as camera 1

NB. The sequence must start with 1; the maximum is 16. If an entrance has 2 cameras then it will have 2 consecutive addresses.

Each controller must also record the last camera number in the sequence – this will be the same setting for all participating entrances.

BF Apartment Station 1 Way System

Below are a couple of examples and a blank table for your use.

Example 1: -

Entrance number	# Cameras at this entrance	First Camera DIP SW3 (1-4)	Last Camera DIP SW3 (5-8)
A	2	1	5
B	1	3	5
C	2	4	5

Example 2: -

Entrance	# Cameras at this entrance	First Camera DIP SW3 (1-4)	Last Camera DIP SW3 (5-8)
A	1	1	3
B	2	2	3

Customer's setup: -

Entrance	# Cameras at this entrance	First Camera DIP SW3 (1-4)	Last Camera DIP SW3 (5-8)
A			
B			
C			
D			
E			
F			
G			
H			
I			
J			
K			
L			

BFD1 Door Controller Jumper Settings

Camera Terminator

There is a separate jumper for both video Camera inputs. This has three settings, 75R for terminating coaxial cable, 100R for terminating twisted pair Cat5 cable and None for use when passing the cable on to another device or controller.

Video Gain Control

The "Video Gain" jumper on door controllers should always be set to "0" unless directed by 'Bell System Technical Support'. This jumper is only required on some systems with very long cable runs, camera to apartment station well in excess of 150m. Inappropriate use of this jumper with short runs will cause picture problems.

Reassurance tones

DDA reassurance tones for "ringing" and "door open" are available at the door panel. The volume is adjustable from 0 using the volume control on the BFD1 controller PCB (see the diagram on page 31).

The lock tone is always active and the ring tone is activated by placing a jumper between pins 5 & 6 of the "Prog-6" pin header on the BFD1 controller PCB, the jumper is stored between pins 1 & 2.

Door Speech Volume Adjustment

Introduction

The speech level heard by a caller at the door is adjustable by use of three pushbuttons on the BFD1 door controller. This is useful if the door is on a noisy street, or alternatively in a quiet location. Speech gain in the other direction is fixed.

Method

To perform volume adjustment, first borrow the jumper from Prog-6 and place it on the two pin header ZLK. The Yellow Speech LED should light.

WARNING. A power fail during a Save may require the unit to be returned to Bell System for reprogramming. Do not perform volume adjustment without the jumper in place.

8 presses of Vol+ doubles the volume level and 8 presses of Vol- halves it. Pressing Save stores the new value. Increasing the volume too far will make speech less stable and there will be a tendency for feedback – intermittent screeching and howling. If this happens press Vol- four times and Save and test again.

The new level is tested by ringing one or more apartment stations and talking to them.

Finally return the jumper to its original location on Prog-6.

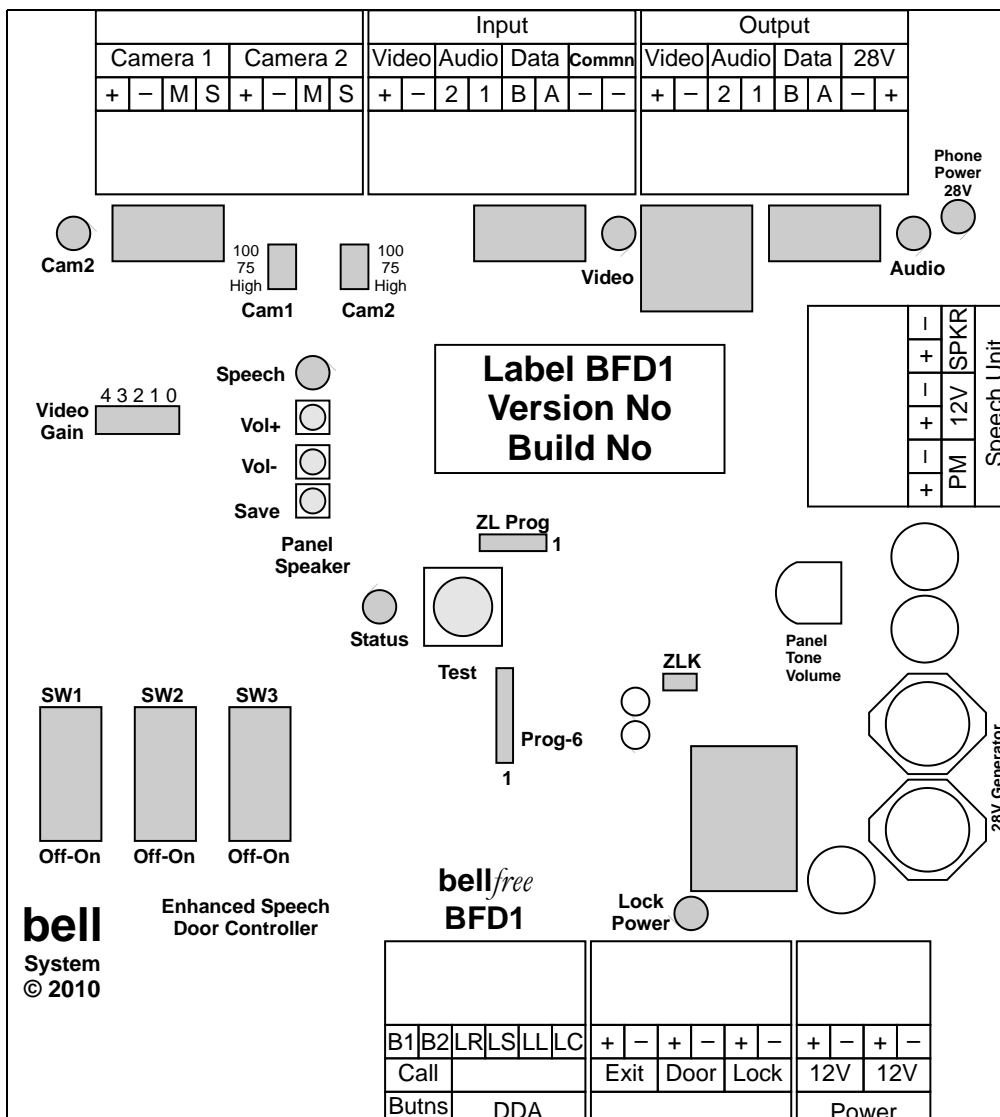

BF Apartment Station Switch Settings

Mute Time Setting SW (1-4)

1	2	3	4	Mute Time
On	On	On	On	Disabled ¹
Off	On	On	On	2 minutes
On	Off	On	On	5 minutes
Off	Off	On	On	10 minutes
On	On	Off	On	15 minutes
Off	On	Off	On	20 minutes
On	Off	Off	On	30 minutes
Off	Off	Off	On	45 minutes
On	On	On	Off	1 hour
Off	On	On	Off	2 hours
On	Off	On	Off	4 hours
Off	Off	On	Off	5 hours
On	On	Off	Off	6 hours
Off	On	Off	Off	8 hours
On	Off	Off	Off	10 hours
Off	Off	Off	Off	*Indefinite²

SW

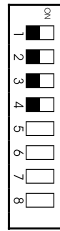

OFF ↔ ON

*Default setting

¹Disabled means touching the *mute* symbol has no effect.

²Indefinite; the *mute* is cancelled by touching the symbol again.

SW



OFF ↔ ON

Individual Functions DIP-SW (5-8)

SW-5	Master / Extension	Which Apartment Station to set
*Off	Master	Only or first apartment station per BSC4 output.
On	Extension / Slave	Second and subsequent apartment stations per BSC4 output.
SW-6	Auto Display on Ring	Apartment Station display behaviour
*Off	Display during ring	Picture is on while ringing, stays on when answered.
On	No display during ring	Picture is off while ringing, comes on when answered.
SW-7	Spare	Spare
*Off		
On		
SW-8	Spare	Spare
*Off		
On		

*Default setting

Video Terminator Jumper Setting

The jumper is situated next to the input connector. It is 3 pin and labelled On and Off.

The jumper should be on when there is only one apartment station. Otherwise only the last apartment station should have a jumper set to On the rest being set to Off.

BS Videophone Switch Settings

Mute Time Settings (1-4)

4	3	2	1	Mute Time
On	On	On	On	Disabled ¹
On	On	On	Off	2 minutes
On	On	Off	On	5 minutes
On	On	Off	Off	10 minutes
On	Off	On	On	15 minutes
On	Off	On	Off	20 minutes
On	Off	Off	On	30 minutes
On	Off	Off	Off	45 minutes
Off	On	On	On	1 hour
Off	On	On	Off	2 hours
Off	On	Off	On	4 hours
Off	On	Off	Off	5 hours
Off	Off	On	On	6 hours
Off	Off	On	Off	8 hours
Off	Off	Off	On	10 hours
Off	Off	Off	Off	*Indefinite²

*Default setting

¹Disabled means pressing the **mute** button has no effect.

²Indefinite; the **mute** is cancelled by pressing the button again.

Settings

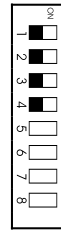

OFF ↔ ON

Settings

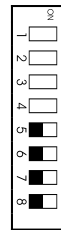

OFF ↔ ON

Individual Functions Settings (5-8)

5	Master / Extension	Which videophone to set
*Off	Master	Only or first videophone per BSC4 output.
On	Extension / Slave	Second and subsequent videophones per BSC4 output.
6	Auto Display on Ring	Videophone display behaviour
*Off	Display during ring	Picture is on while ringing, stays on when answered.
On	No display during ring	Picture is off while ringing, comes on when answered.
7	Spare	
*Off		
On		
8	Spare	
*Off		
On		

*Default setting

Video Terminator Jumper Setting

The jumper is situated above the input connector. It is 3 pin and labelled On and Off.

The jumper should be on when there is only one videophone. Otherwise only the last videophone should have a jumper set to On the rest being set to Off.

Troubleshooting

Common Faults

A very high percentage of calls to our technical support number, regarding new installations, are resolved to faulty wiring. The reasons for these are various: -

Broken cores, especially short links, sometimes broken inside the insulation!

Connectors clamped onto the insulation instead of copper.

Wire in the wrong side of a rising clamp connection, the clamps need to be unscrewed far enough to stop the wire going “underneath”.

Shorts or opens due to cables having been stapled or nailed through.

A common fault is wiring a connector left to right instead of right to left, or one or more twisted pairs the wrong way round.

Tip. The heads of screws on connectors are not a reliable means of making a connection with a meter, try pushing the probe into the wire entry point.

Quick Fault Reference

These tables provide a quick indication of the possible fault.

Power Problems	
Apartment station resetting (The three indicators lights show the power on sequence).	<ul style="list-style-type: none"> • Power supply intermittent short or overload. • More than 1 extension enabled for auto display. • Lock output short-circuit; see 'Lock Problems'.
28V LED does not light on controller.	<ul style="list-style-type: none"> • Temporarily remove connection to 28V+ output. If it now comes on there is a short on the apartment station wiring. • 12V input connections are reversed.
PS4 output voltage fluctuating, meter reading unstable.	<ul style="list-style-type: none"> • Output overload is causing current limit to operate. • See Lock Problems below.

Call Problems	
Apartment station does not ring or flash when called.	<ul style="list-style-type: none"> • No power to apartment station; check that red lamp illuminates when mute is touched. • Data wiring has a fault, Data A or Data B connection broken. • 0V to controller missing on separately powered apartment station. • Pushbutton wiring error, try short length at controller.
No extension apartment station rings or flashes when called.	<ul style="list-style-type: none"> • Data wiring has a fault, Data A or Data B connection broken.
Green Lock light on apartment station flashes once when called.	<ul style="list-style-type: none"> • Apartment station set to extension with no master present or responding.

BF Apartment Station 1 Way System

Lock Release Problems	
Lock release does not operate or clicks but does not open.	<ul style="list-style-type: none"> • Connections to Lock Release are open or shorted. • Voltage drop due to cable too thin. • Lock current is too high; Power supply is resetting. • Lock release jammed due to over tight fitting.
Maglock does not hold strongly.	<ul style="list-style-type: none"> • Voltage drop due to cable too thin.
TEST: Press 'Test' Button on Door Controller (when system idle):	<ul style="list-style-type: none"> • Confirm 'LOCK' LED illuminates for 3 seconds. • Check Output Voltage at LOCK terminals.
Lock release operates all the time or in reverse.	<ul style="list-style-type: none"> • Check fail safe/fail secure SW2-4 selection matches the lock type. • Normally closed switch has been used for exit button.
Lock operates from the exit button but not the test button or apartment station.	<ul style="list-style-type: none"> • Normally closed switch has been used for exit button.

Video Problems	
Blank picture when: - Calling apartment station or touching view .	<ul style="list-style-type: none"> • Broken or missing Video + or Video - connection. • Cameras incorrectly configured refer to SW2-6 settings on page 19 • Call is from an audio only panel.
No picture when calling apartment station.	<ul style="list-style-type: none"> • Check Auto display switch is on. See page 23.
No picture when touching view for CCTV mode.	<ul style="list-style-type: none"> • Another apartment station in use. • No entrance has SW2-8 set to 'Enable'.
Repeated touching of view does not select cameras in sequence as expected.	<ul style="list-style-type: none"> • Check SW2-6 at all entrances is set for correct number of cameras at that entrance. • Check settings for SW3 if SW2-7 is enabled. • See section 'Global View' on page 20.
Unstable picture.	<ul style="list-style-type: none"> • Power supply voltage low. • Terminator switch not set on last apartment station. • Too many terminator switches set on. • Video gain jumper set to high on a short run. • Very bright area in background upsetting camera.
Unstable picture possibly with areas looking like a photographic negative.	<ul style="list-style-type: none"> • Video + and Video - reversed, or M and S reversed.
Entrance cannot be seen at night.	<ul style="list-style-type: none"> • Power not connected to camera IR night illumination. Connect 1 to + on camera.

BF Apartment Station 1 Way System

Speech Problems	
Loud tone at the entrance speaker. (Acoustic feedback).	<ul style="list-style-type: none">• Broken Audio 1 or Audio 2 connection.• Intermittent or broken Data A or Data B connection.• Apartment station has reset; see the power faults table.• More than one entrance has SW2-8 set to 'Enable' causing 2 entrances to become active on CCTV request.
No speech from apartment station to entrance.	<ul style="list-style-type: none">• Missing or Broken Spkr+ or Spkr - connection.
No speech from entrance to apartment station.	<ul style="list-style-type: none">• Missing or Broken PM + or PM - connection.

BF Apartment Station 1 Way System

Specifications

BFD1 Door controller	
Size	185mm x 230mm x 42mm
Supply Voltage	10.8V min, 13.8V typical, 15V max
Current Consumption	80mA idle @ 13.8V, 250mA active includes speech not cameras

Model CAMBS-C Colour Camera	
Size	60mm x 57mm x 31mm
Supply Voltage	10V d.c. minimum, 15V d.c. maximum
Current consumption	175mA maximum without IR 215mA maximum with IR (Link 1 to +)
Image Device	1/3" CCD
Sensitivity	0.01 lux, auto switching to B/W in low light levels
Minimum Focus	100mm
Viewing Angle	92° (typical)
Video Output	PAL composite video 1Vpk-pk (75 Ohm)
Resolution	More than 330 lines
Back light compensation	Yes

BF Colour Apartment Station	
Size	144mm x 202mm x 50mm (20mm When flush)
Fixing	Wall Mounted
Supply Voltage	11V minimum – local power supply only. 20V to 28V typical
Current Consumption	25mA @28V idle, 375mA @ 11V active
Buzzer Mute Time	Disabled, 1minute through 10 hours, indefinite

BS Colour Videophone	
Size	180mm x 225mm x 60mm
Fixing	Wall Mounted
Supply Voltage	11V minimum – local power supply only. 20V to 28V typical
Current Consumption	25mA @28V idle, 375mA @ 11V active
Buzzer Mute Time	Disabled, 1minute through 10 hours, indefinite

Model BSA Phone	
Size	235mm x 105mm x 25mm
Supply Voltage	10V d.c. minimum, 30V d.c. maximum
Current consumption	20mA idle, 67mA ringing @ 13.8V

BF Apartment Station 1 Way System

Model BF-AMP Speech Unit	
Size	98mm x 60mm x 24mm
Supply Voltage	10.5V d.c. minimum, 15V d.c. maximum
Current consumption	250mA d.c. maximum

PS4 Power Supply	
Size	236mm x 105mm x 81mm
Output Voltage (regulated)	13.5V d.c. min, 13.8V d.c. nom, 14.1V d.c. max
Output Current	3A continuous, 4A peak (5 minutes max)
Mains Supply Internal Fuse	Not user replaceable
Supply Voltage	230V 50Hz nominal
Temperature Range	0 °C to 50 °C

340C Power Supply	
Size	140mm x 60mm x 53mm
Output Voltage (regulated)	13.5V Min, 13.8V Nom, 14.1V Max
Output Current	1A continuous, 1.5A peak (5 minutes max)
Mains Supply Internal Fuse	Not user replaceable
Supply Voltage	230V 50Hz nominal
Temperature Range	0 °C to 50 °C

840 Power Supply – Battery Backed	
Size	350mm x 330mm x 80mm
Output Voltage (regulated)	13.5V Min, 13.8V Nom, 14.1V Max
Output Current	3A continuous, 4A peak (5 minutes max)
Mains Supply Internal Fuse	T2A 20mm HBC (HRC) Ceramic
Battery Fuse	F4A 20mm Glass
Supply Voltage	230V 50Hz nominal
Temperature Range	0 °C to 50 °C

Diagram A – 1 Way Basic System Wiring Overview

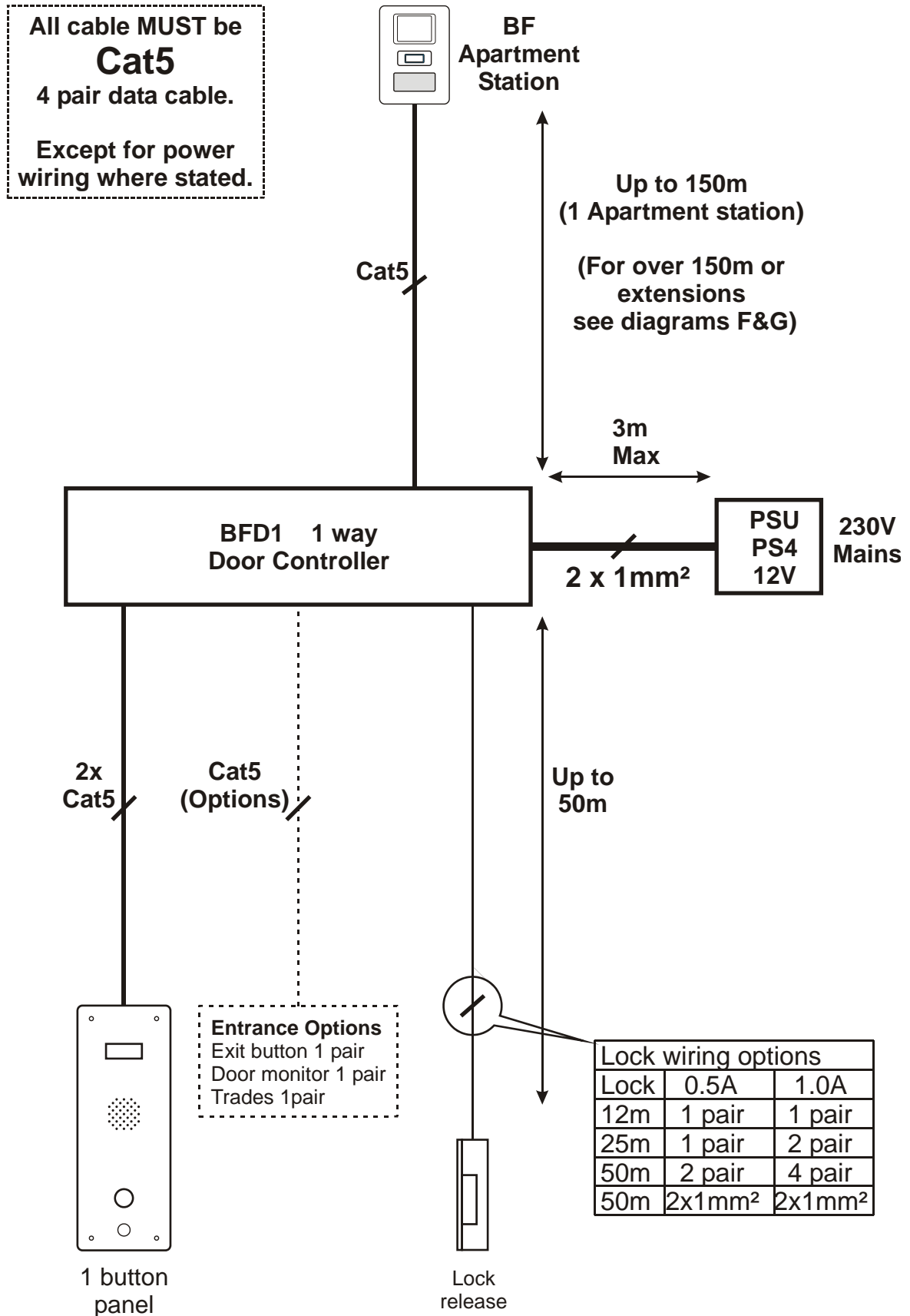

Diagram B – 1 Way PCB Detail

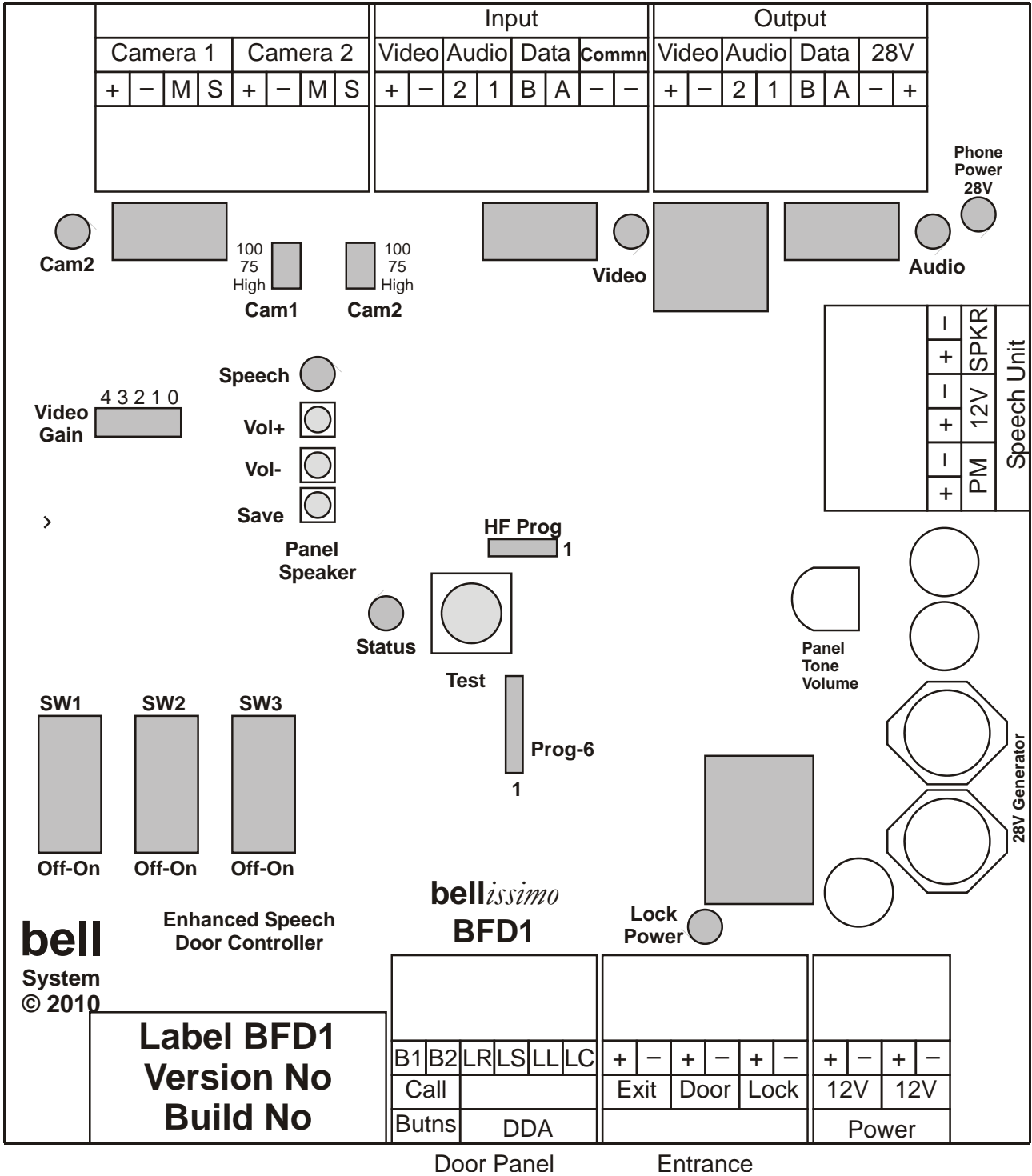

Diagram C – 1 Way Basic System Wiring Detail

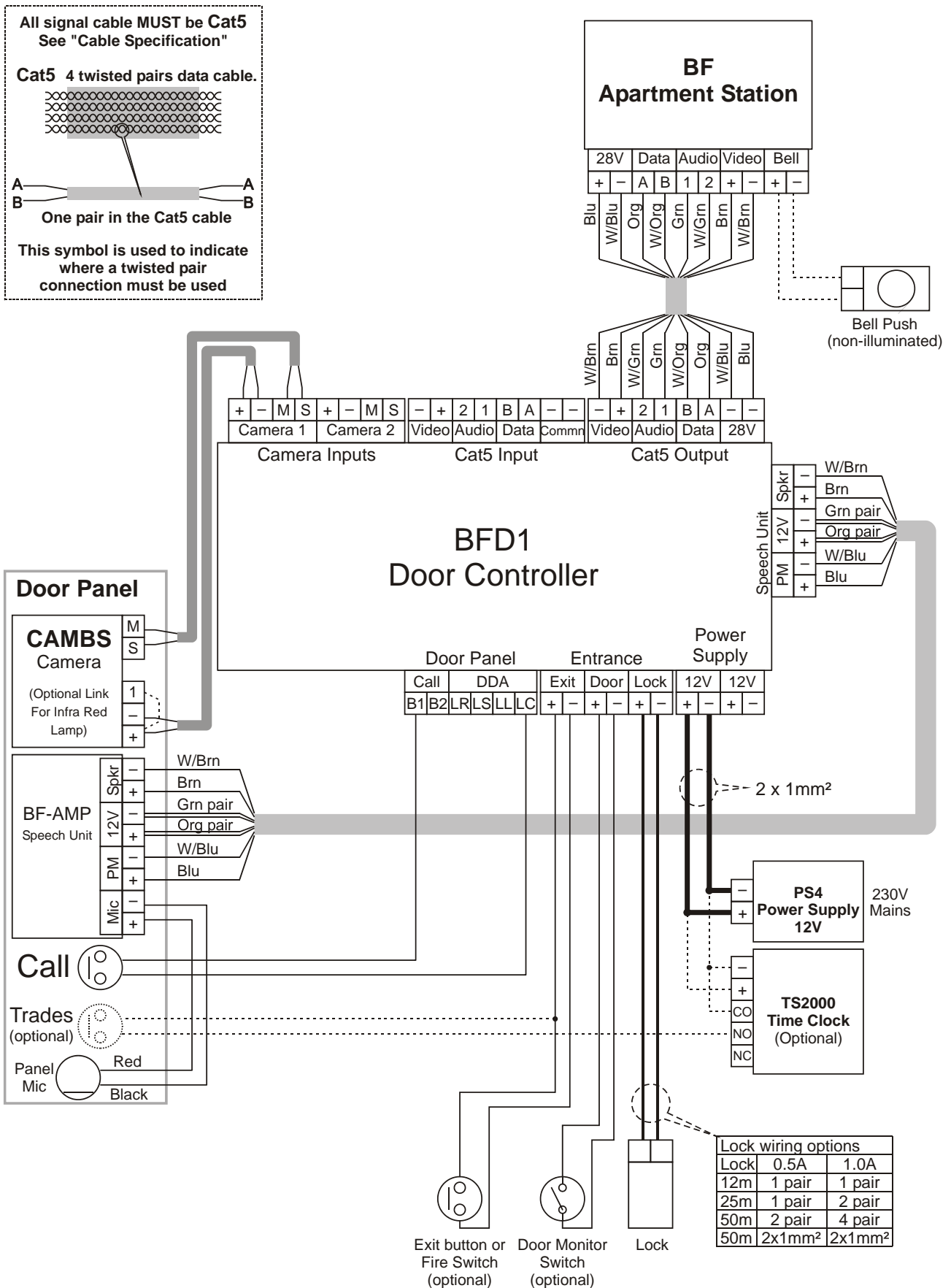

Diagram D – 1 Way Multiple Entrance Wiring Overview

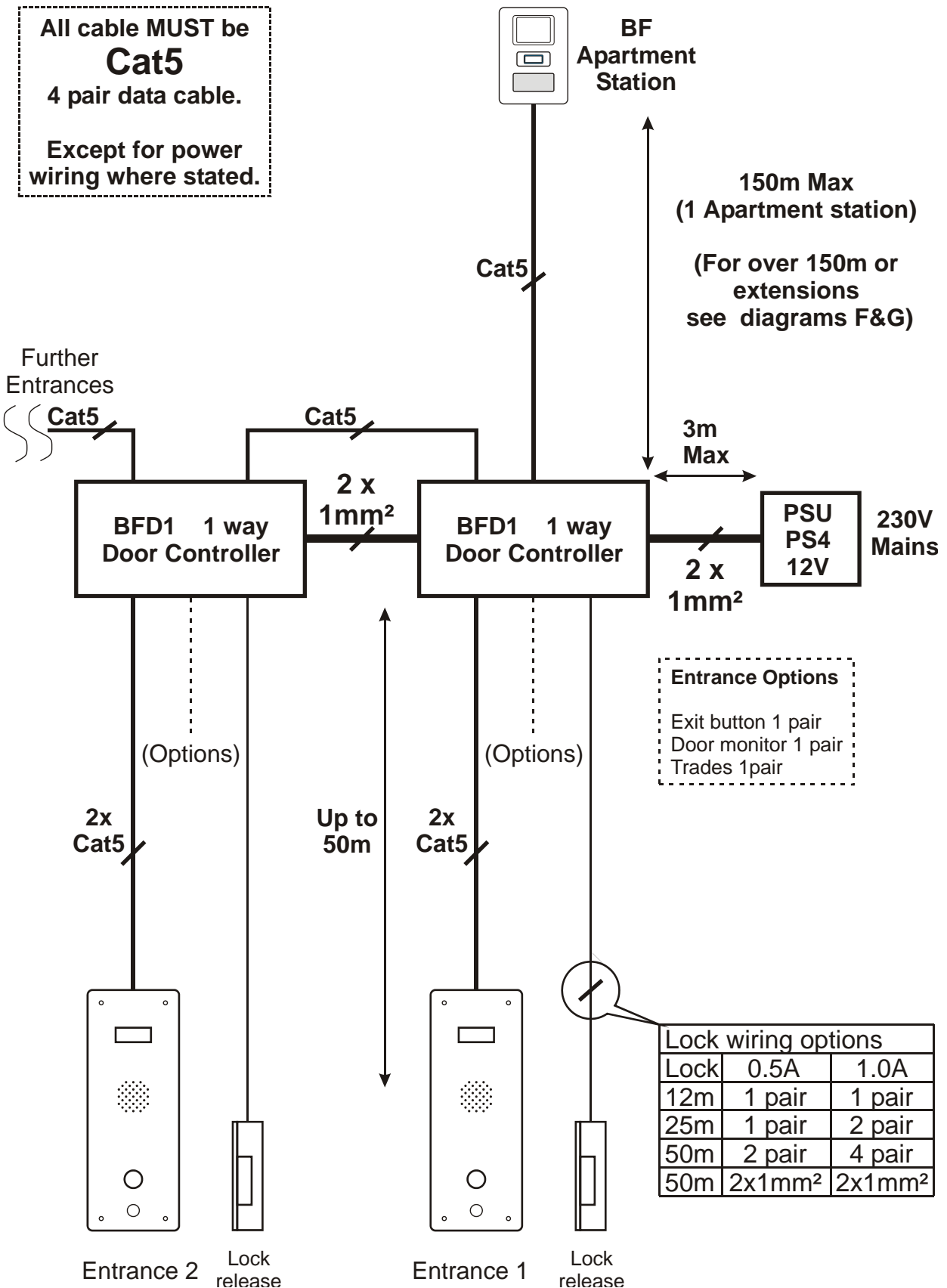
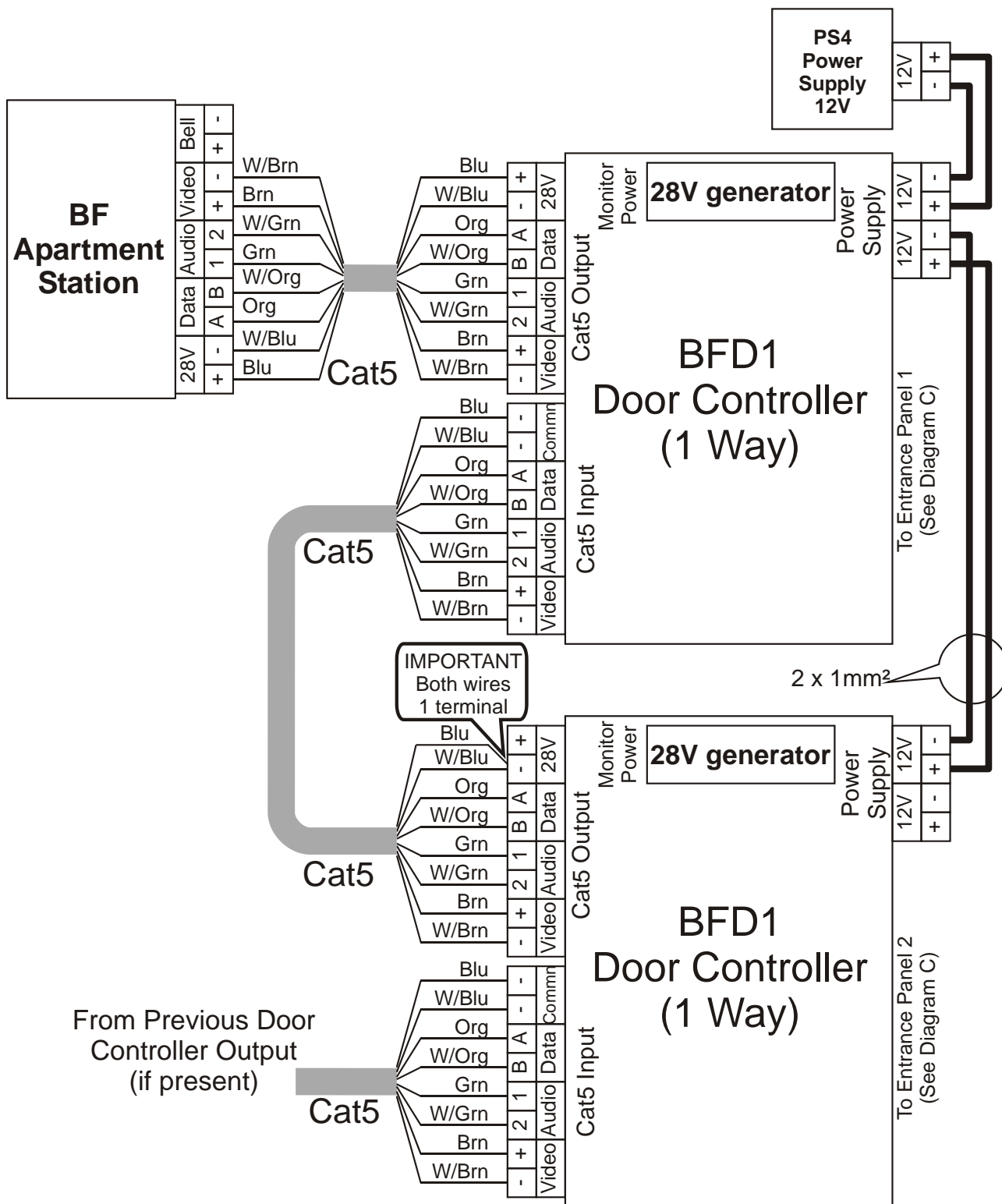
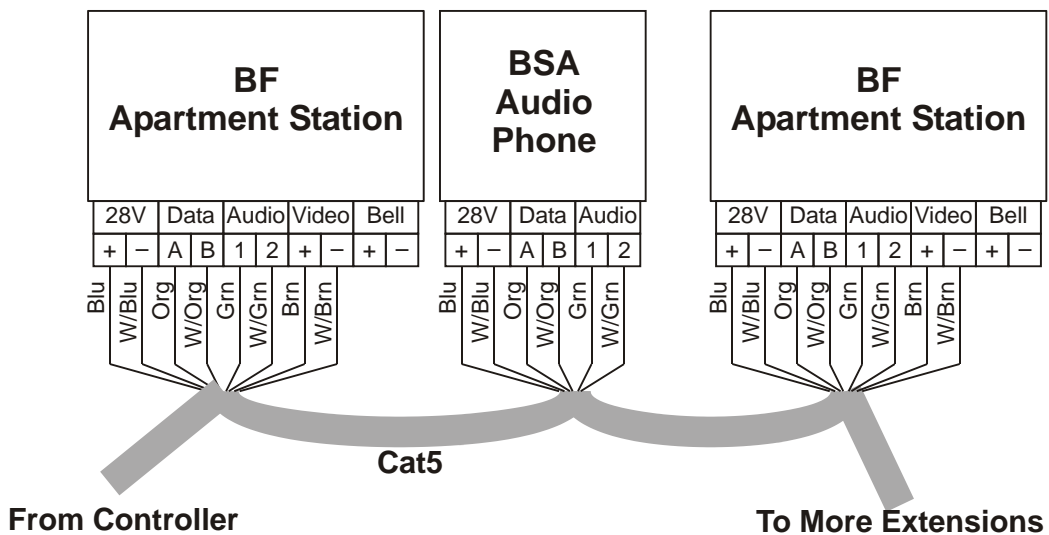
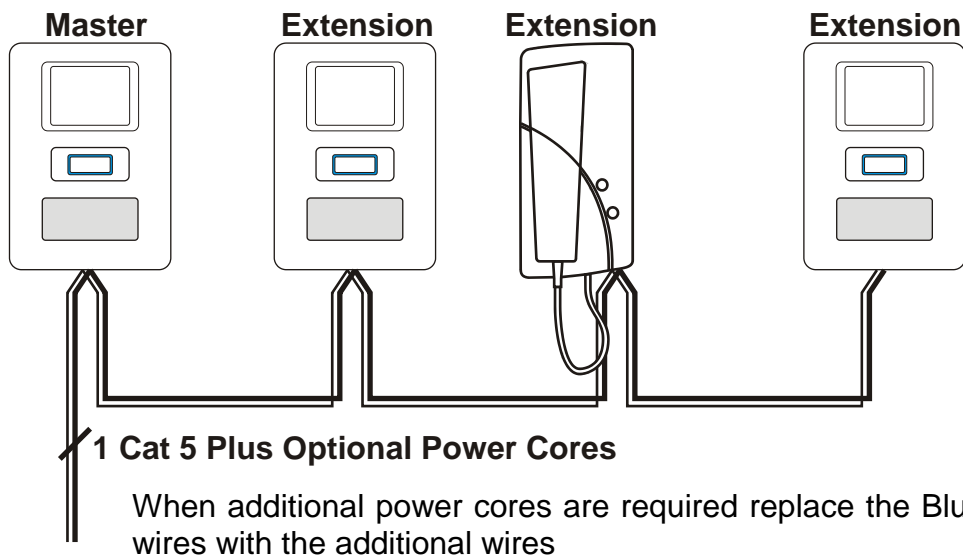

Diagram E – 1 Way Multiple Entrance Wiring Detail



For detailed entrance wiring see Diagram C

Diagram F – Extension Apartment station Wiring



Note. For each cable run :-

- Only one unit must be Master (Recommend the first unit)
- Auto display on one video unit only (For auto display on multiple video units see next Diagram)
- Extension video units must be "daisy chain" wired to preserve video quality
- The last (or only) video unit on the cable requires the Video Terminator "ON" all other video units must have the Video Terminator "OFF"

Diagram G – Apartment station Local Power Wiring

Where more than one extension video unit is required to provide "auto display" then additional power supplies will be required

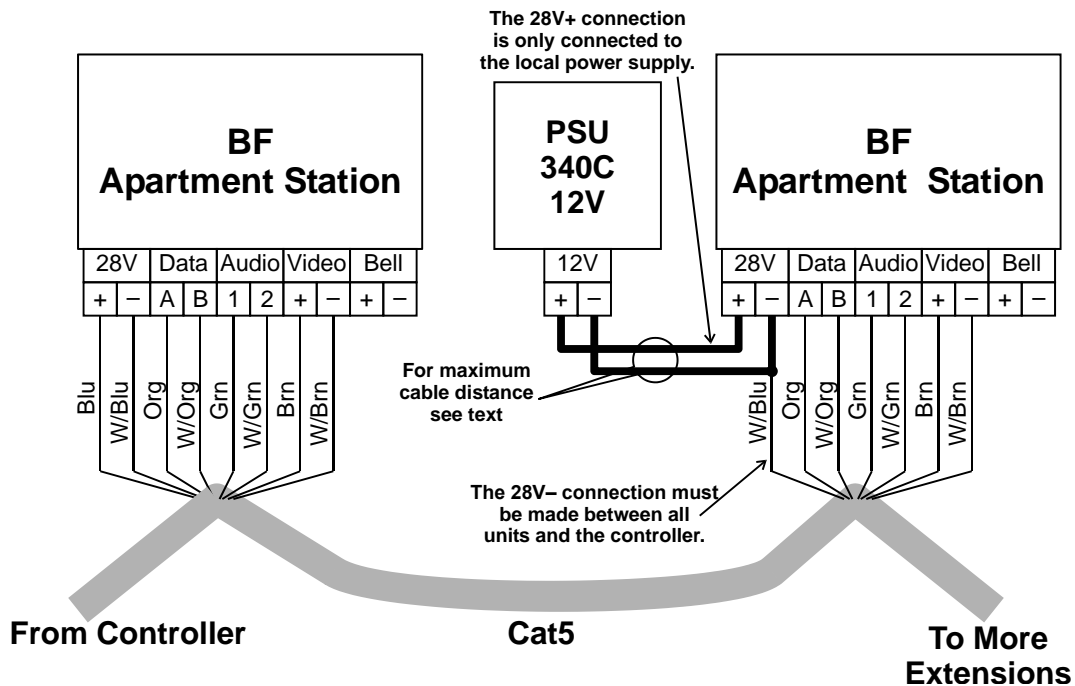
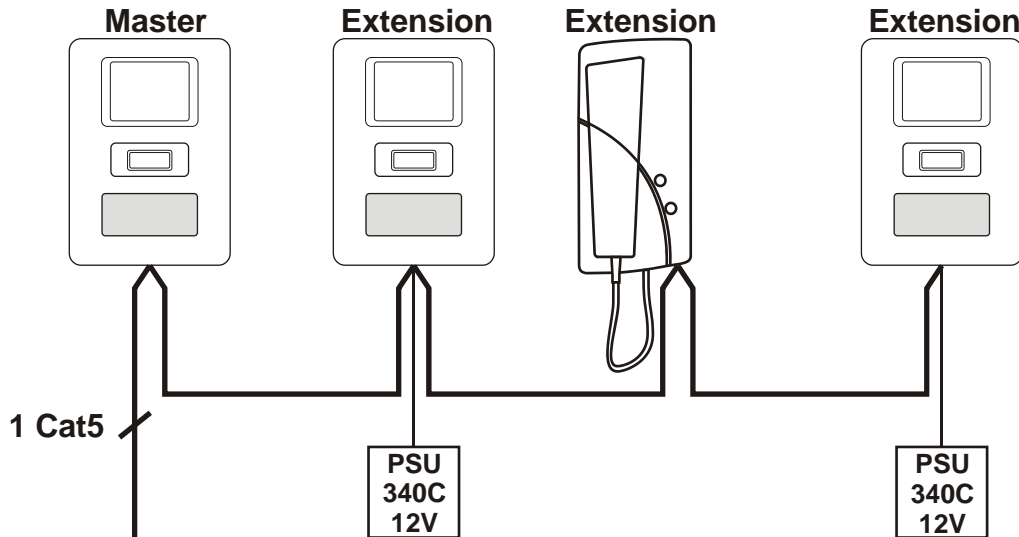

Note. For each cable run :-

- Only one unit must be Master (Recommend the first unit)
- Extension video units must be "daisy chain" wired to preserve video quality
- The last (or only) video unit on the cable requires the Video Terminator "ON" all other video units must have the Video Terminator "OFF"

Diagram H – Camera Sharing & Time Clock Sharing

Camera Termination Options

Cameras may be wired in either twisted pair or coax and shared with other equipment.

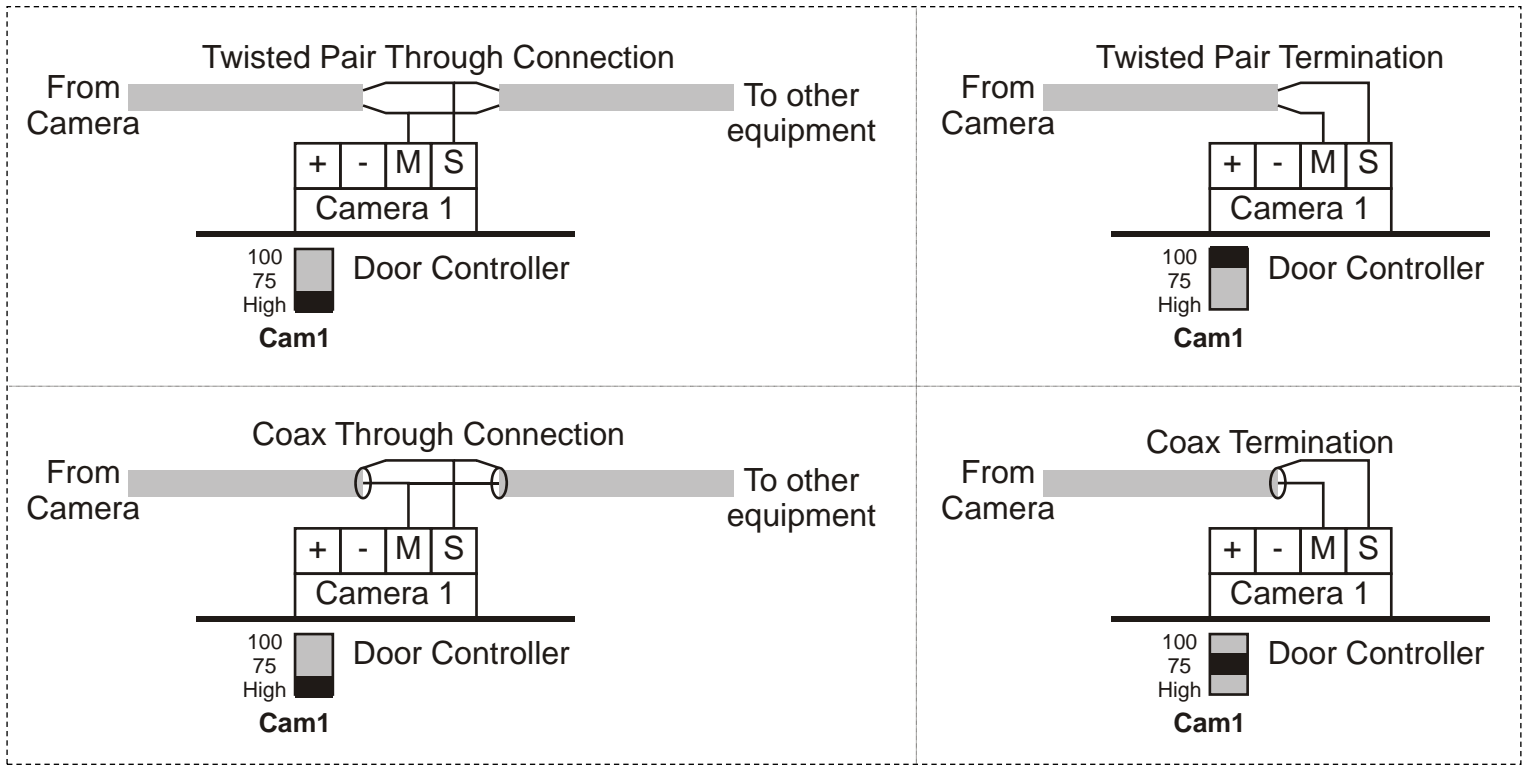

Time Clock Sharing

A time clock can be shared between distributed equipment areas by borrowing one of the 'comm -' wires in the interconnecting Cat5 to use as the shared "Time clock common".

The "Time clock common" signal is sharable across all Bell controller types.

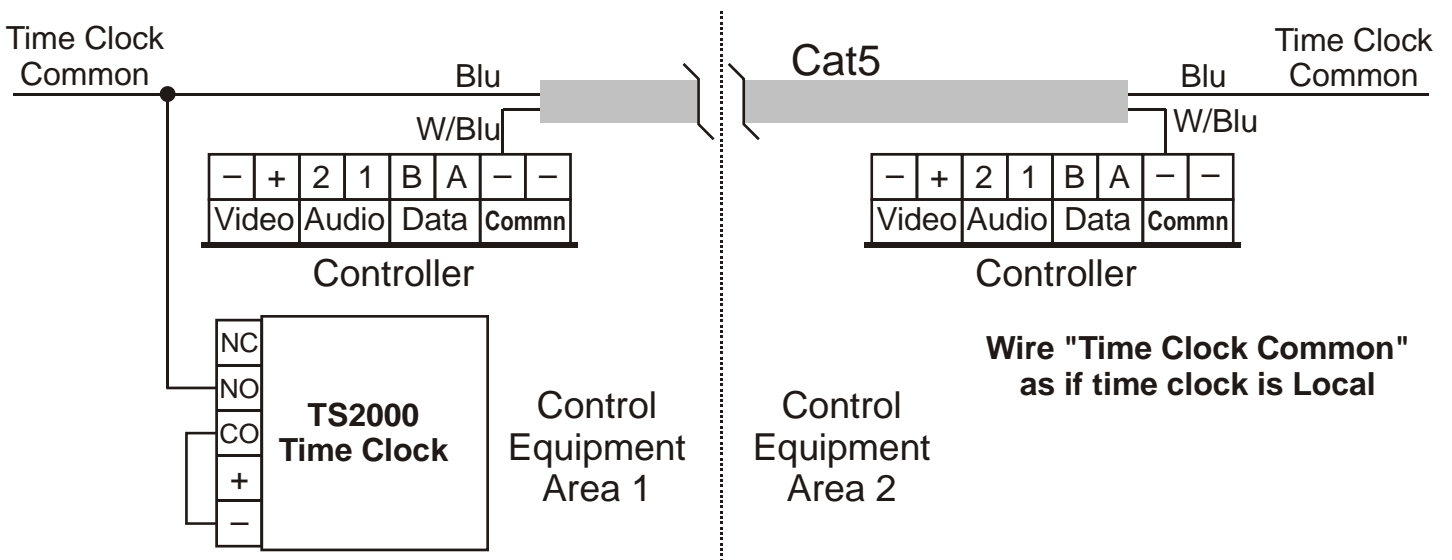

Diagram I – 1 Way DDA Panel Wiring

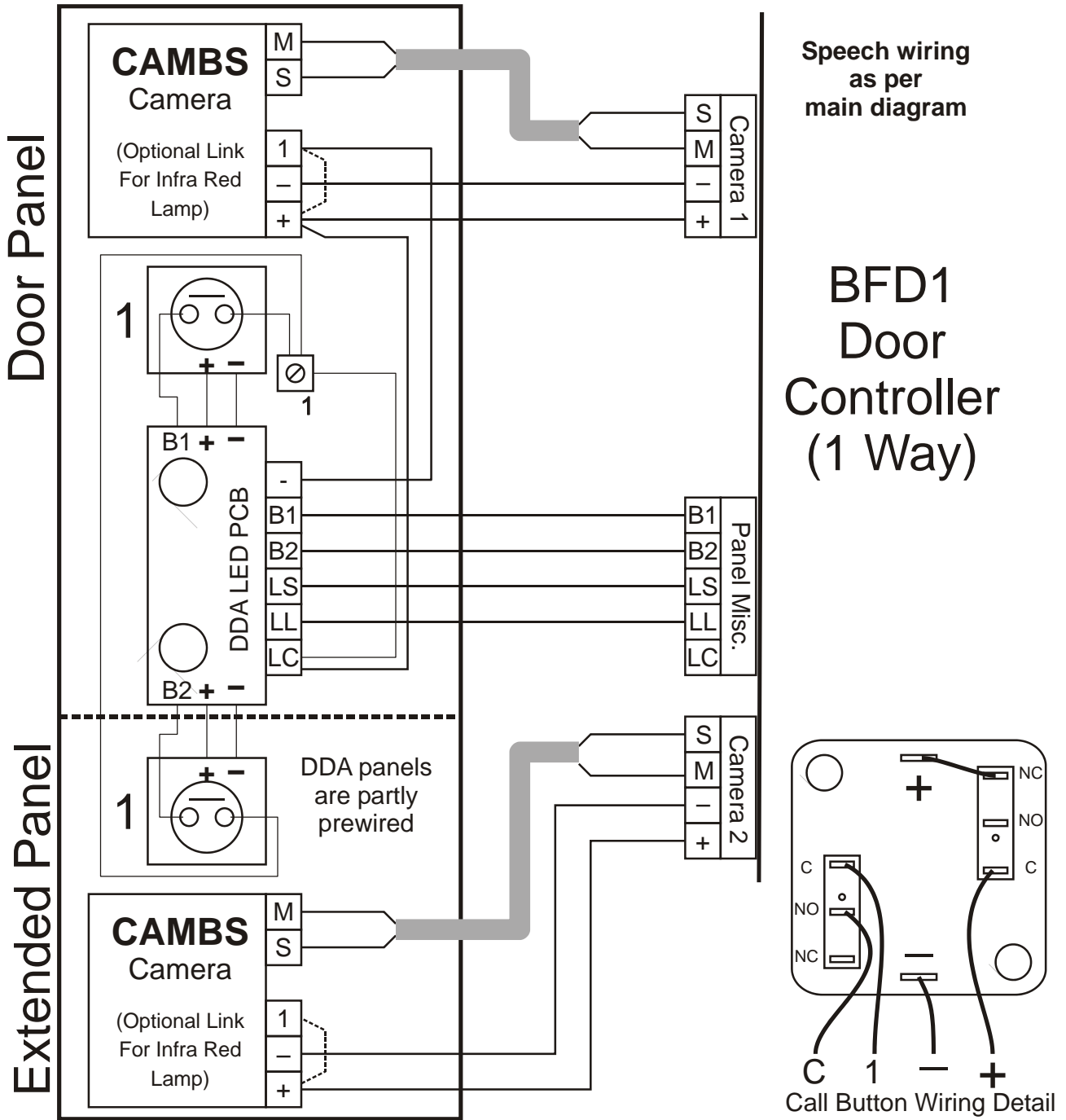
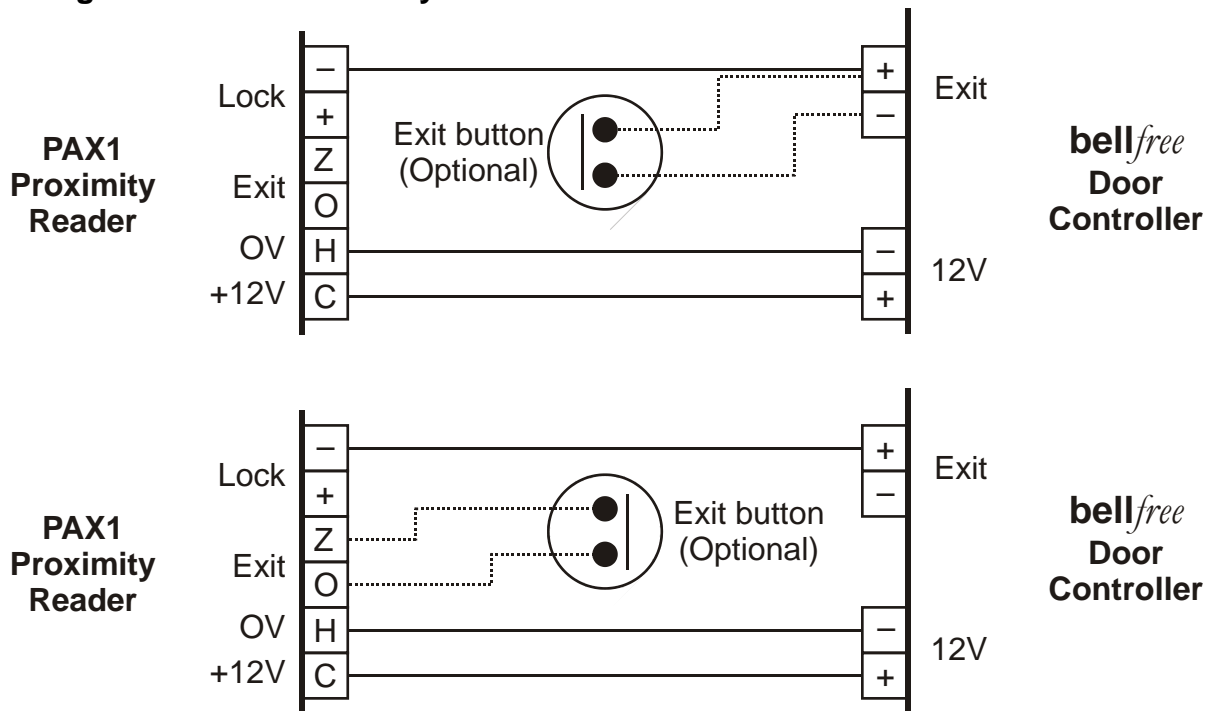

Diagram J – Combined Connections bell*free* With Lock

Connecting a Bell PAX1 Proximity Reader



Connect the lock release as per this manual. Leave the Proximity Reader set to fail secure, the BFD controller sets the lock type.

Use a lock time card to reduce the lock time to 1 or 2 seconds, otherwise the PAX1 will extend the bell*free* lock time to 7 seconds. Lock time cards are in all Fob packs except the starter pack.

Note 1. A normally open exit button can still be wired to the BFD controller in addition to the proximity wiring. Alternatively the exit button can be wired to the proximity reader

ACT 1000/2000/3000 Proximity Controller or 100e/200e Extender

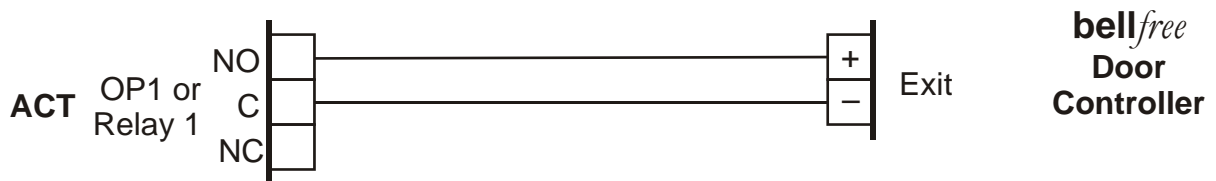

The lock output on an ACT controller is a volt free relay contact, so as long as it is not used for another purpose it can be directly connected to the exit input of a bell*free* door controller.

A 2 wire interface is shown, but if a common 12V supply is in use then the Exit-input may be left unconnected and the corresponding ACT relay connection can be connected to a local 0V terminal.

Diagram J – Continued

Connecting a Bellcode Coded Access Controller

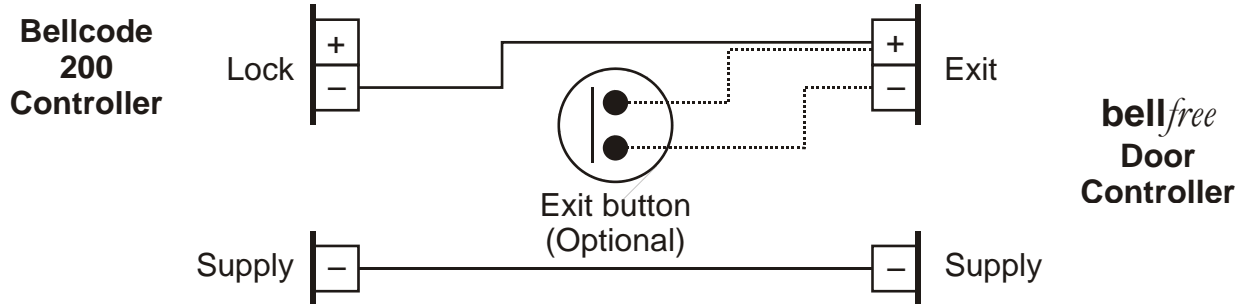

Connect the lock release as per this manual. Leave the Bellcode controller set to fail secure, the BFD controller sets the lock type.

See "Bellcode Manual inc CK200 CS109 (PD-078)" for the other installation and setting instructions.

- Note 1. A normally open exit button can still be wired to the Bellcode unit in addition to the bellfree wiring.
- Note 2. A "12V-" connection will be required if the 2 units are not sharing a power supply.

Taking an Output From a Third Party System

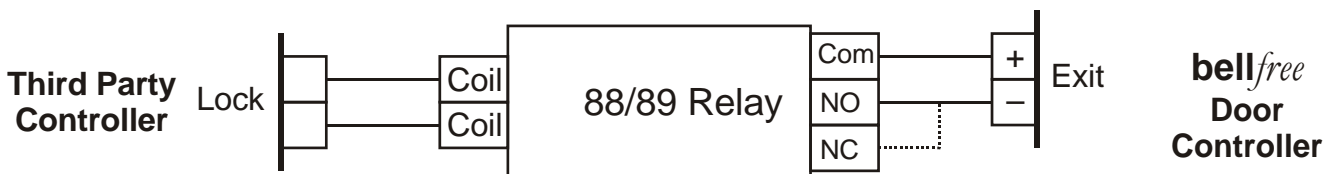

For 12V a.c. systems use an 88 relay and for 12 d.c. systems use an 89 relay. For systems with other lock voltages, a relay with a suitably rated coil will be required.

For systems with a fail safe output the common and normally closed contacts will be required.

Diagram K – Combined Connections Third Party Lock

Connecting a Bell PAX1 Proximity Reader

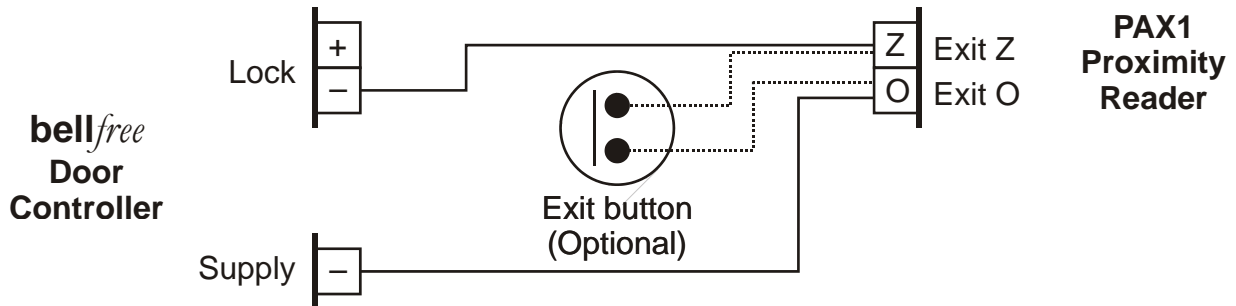

The bellfree door controller is set to fail secure. The diagram assumes a common power supply, if not an extra wire will be required to connect the PAX1 Exit O to the bellfree 12V-.

N.B. The power wiring to the PAX1 must be able to carry the lock current with less than 2V voltage drop.

ACT 1000/2000/3000 Proximity Controller or 100e/200e Extender

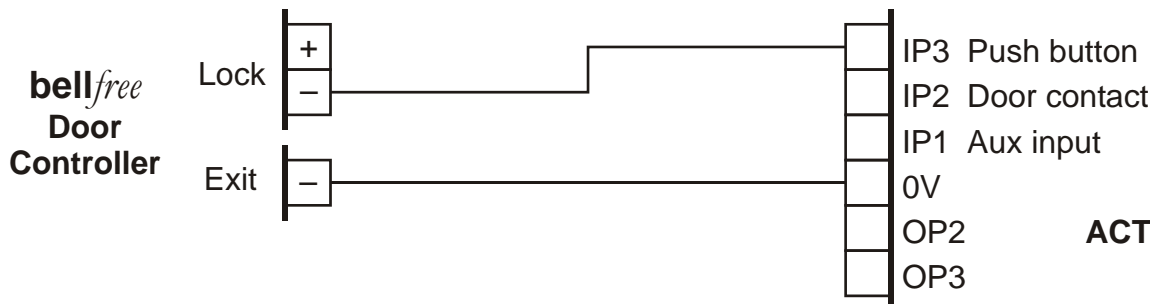

Notes

1. Connect the lock release or Maglock using the ACT Manuals.
2. Leave the bellfree controller set to Fail Secure regardless of the type of release used.
3. A normally open exit button can still be fitted to the ACT controller in addition to the bellfree wiring.
4. If the 2 units are not sharing a power supply, then a connection from bellfree controller Exit- to ACT 0V will be required.
5. Look for the notes on the ACT installation diagram concerning the use of links when the door contact is not used and when a power supply without power fail is not used.

Diagram K – Continued

Connecting a Bellcode Coded Access Controller

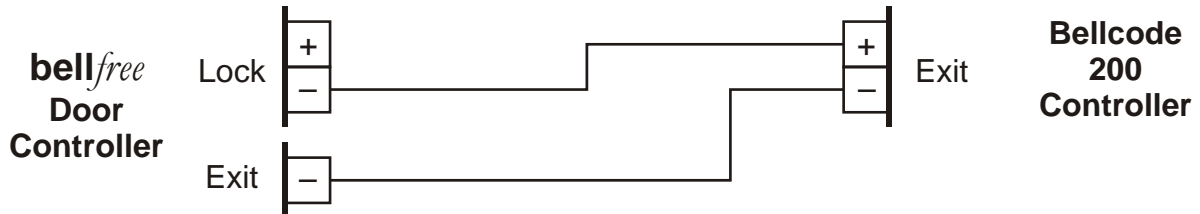

The bellfree door controller is set to fail secure.

The Exit- to Exit- wire is only needed if the two units do not share a common power supply.

Opening a Gate or Locks on Third Party Systems

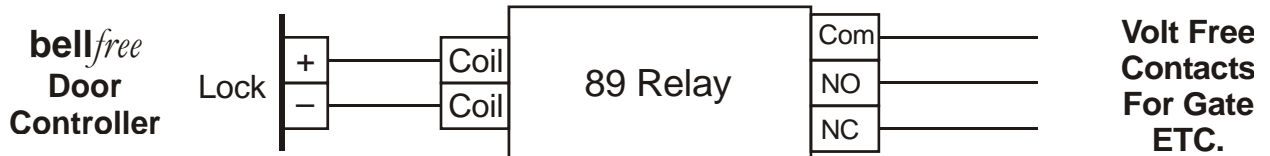

The bellfree door controller is set to fail secure.

Use COM and NO or COM and NC as required for the gate controller or third party access system.

Safety Information and Declarations

Connections to the 240VAC mains supply must be carried out by a qualified electrician or similar competent person, and made in accordance with current legislative requirements. A two-pole switch (as provided by a Consumer Unit or Switch-Fuse) must be included to isolate both Live and Neutral during Installation or Maintenance. The circuit must be protected by a fuse or other current-limiting device, rated according to the capacity of the cable used, up to a maximum of 10A. Use only mains cable to BS6004 or equivalent, within the following specified limits:

	Min	Max
Conductor Diameter	1.0mm (0.8mm ²)	2.25mm (4mm ²)
Cable Diameter	4.0mm	8.0mm

Model 840 Power Supply (with battery standby)

The Model 840 power supply must be placed in a protected indoor environment such as an electrical cupboard. It must be secured to the wall with adequate fixings so that there is no possibility of it falling. The Lead-Acid Battery for the Standby Power Supply is shipped in separate packaging. It should only be connected once the system has been fully tested. Connection is made by 2 leads with spade terminals; observe the correct polarity – red to positive, black to negative. Care must be taken to ensure that the terminals of the battery are not shorted together by metal objects, as this may constitute a Fire Hazard. The Control Cabinet is IP55 rated (to exclude dust) and is vented to avoid the build-up of gases. Do not block any vents that may be apparent.

A good mains safety earth must be connected to the cabinet housing the power supply

Where the power supply is fitted with a replaceable internal mains fuse and or battery fuse, always replace with the same type as indicated on the power supply. The fuse must be approved to BS EN 60127 or equivalent.

Power Supply Model	Mains Fuse (Time Delay)	Battery Fuse (Quick Blow)
840	T2A 20mm HBC (HRC) Ceramic	F4A 20mm Glass

Model PS4 and 340C Power Supplies

These power supplies must be wall-mounted onto plasterboard, or a similar non-conductive material, in a protected indoor environment such as an electrical cupboard.

When fitting the power supply cable (both mains and low voltage) ensure the cable entry cut-outs in the enclosure lid are no larger than necessary for the cable diameter used and under no circumstances must they be taken beyond the outer cut-out zones.

BF Apartment Station 1 Way System

Bell System (Telephones) Ltd.

Presley Way,
Crown Hill,
Milton Keynes
MK8 0ET.

Tel: 01908 261106 (Sales and Technical Support)

FAX: 01908 261116

OR

Local rate numbers

Tel: 0845 121 4008 (Sales and Technical Support)

FAX: 0845 121 4009

E-mail: sales@bellsystem.co.uk

technical@bellsystem.co.uk

Website: www.bellsystem.co.uk

Standards

This product complies with European directive 89/336/EEC on Electromagnetic Compatibility and Low Voltage Directive 72/23/EEC.

Emissions: Generic BSEN 61000-6-3

Immunity: Generic BSEN 61000-6-1

Low Voltage: Generic BSEN 60950



bell
system
(Telephones) Ltd



BS EN ISO 9001:2008 Certificate number GB2000389