

Group: Mini Chiller

Part Number: A08019024588

Date: February 2005

AIR COOLED CHILLER (R410A SINGLE COMPRESSOR SERIES)

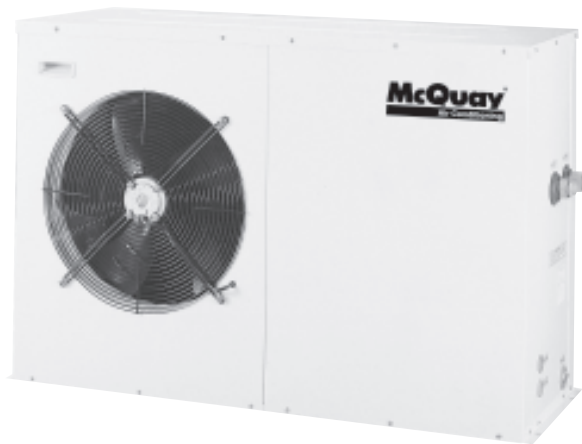

OUTLINE AND DIMENSIONS

5AC 020/025 CR

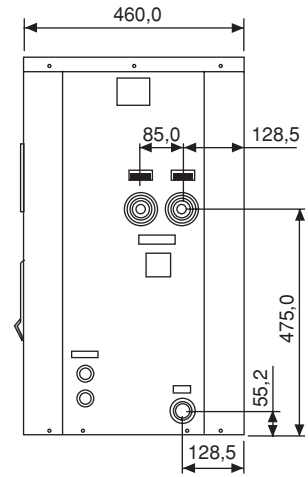
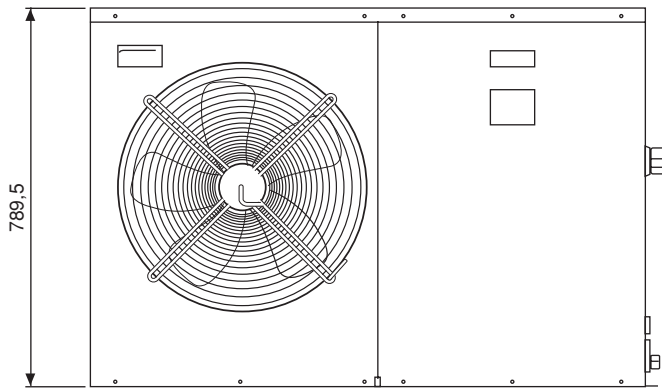
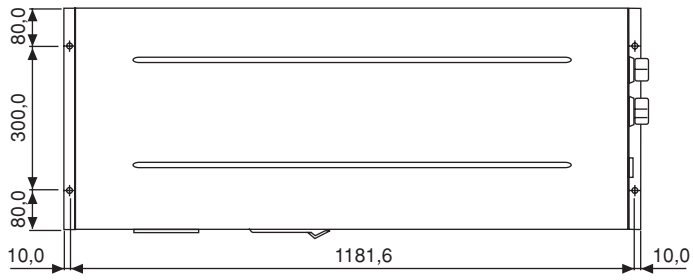



Caution

Sharp edges and coil surfaces are potential locations which may cause injury hazards. Avoid from being in contact with these places.



Avertissement

Les bords coupants et les surfaces du refroidisseur tuulaire présentent un risque de blessure. Mieux vaut éviter le contact avec ces endroits.



Vorsicht

Scharfe Kanten und Wärmetauscherflächen stellen eine Gefahrenquelle dar. Jeglicher Kontakt mit diesen Stellen ist zu vermeiden.



Cautela

Per preservarsi da eventuali ferite, evitare di toccare gli spigoli affilati e la superficie della serpentina.



Cuidado

Los Bordes afilados y la superficie del serpentín pueden producir lesiones. Evite tocarlos.



Осторожно

Острые края и поверхности змеевиков являются потенциальными местами нанесения травм. Остерегайтесь контакта с этими местами.

NOTICE

This product is subjected to Waste of Electrical and Electronic Equipment Regulations (WEEE Regulations). The waste product shall be separately collected by specific collection and treatment centre. Please refer to local authority for these centres. This is only applicable to European Union countries.



Ce produit est soumis à la réglementation concernant les déchets des équipements électriques et électroniques (réglementation DEEE). Le déchet doit être collecté séparément par un centre de collecte et de traitement spécifique. Veuillez vous référer aux autorités locales pour connaître ces centres. Ceci est uniquement applicable aux pays de l'Union Européenne.



Dieses Produkt unterliegt den Bestimmungen zur Entsorgung von elektrischen und elektronischen Geräten (WEEE Bestimmungen). Die Entsorgung sollte am Ende des Lebenszyklus des Gerätes getrennt vom Hausmüll bei Ihrer örtlichen Mülldeponie bzw. Ihrem örtlichen Wiederaufbereitungszentrum erfolgen. Bitte wenden Sie sich an Ihr zuständiges Abfall-Amt. Dieser Hinweis gilt nur für Länder der Europäischen Union.



Questo prodotto è soggetto alle disposizioni RAEE (Rifiuti di apparecchiature elettriche ed elettroniche). Il prodotto da smaltire verrà ritirato da un centro incaricato del ritiro e smaltimento. Per conoscere il nome del centro pertinente, contattare le autorità locali. Questa disposizione è valida solamente i paesi dell'U.E.



Este producto esta sujeto a las Regulaciones del Equipamiento Eléctrico y Electrónico en materia de desechos (Regulaciones WEEE). El producto dañado será retirado por separado por el centro específico de colección y tratamiento. Por favor remitirse a las autoridades locales de estos centros. Esto es solamente aplicable a los países de la Unión Europea.



Процесс утилизации данного продукта регулируется правилами по утилизации отходов электротехнического и электронного оборудования (WEEE Regulations). Такими отходами должен заниматься специальный центр по сборке и обработке отходов. За информацией о таких центрах, обращайтесь к местным властям. Эти правила применяются только в странах Европейского Союза.



ELECTRICAL WIRING DIAGRAM

MODEL : 5AC 020/025 CR

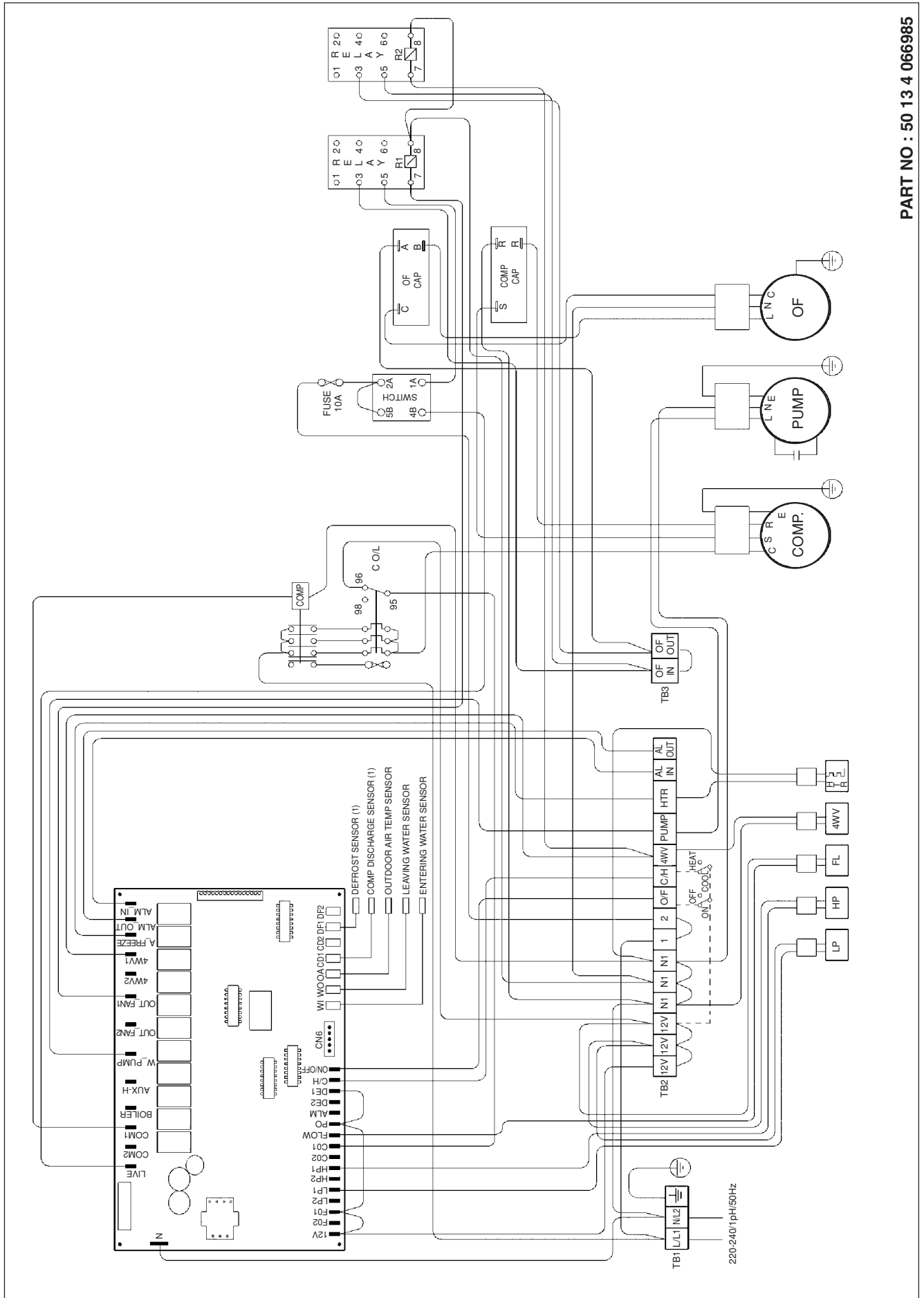

PART NO : 50 13 4 066985

ISOLATOR DIAGRAM

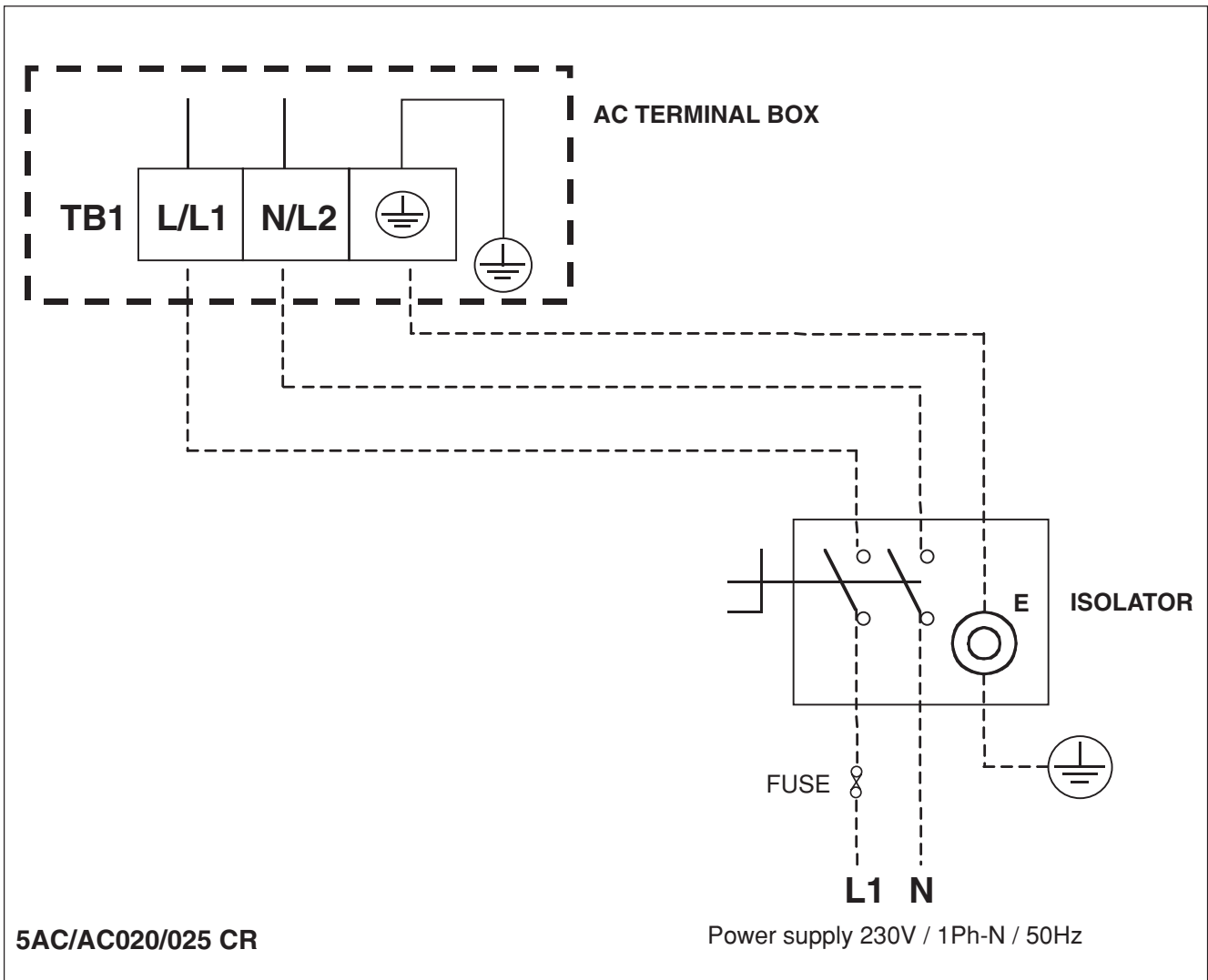

INSTALLATION MANUAL

This manual provides the procedures of installation to ensure a safe and good standard of operation for the chiller.

Special adjustments may be necessary to suit local requirements.

Before using the chiller, please read this instruction manual carefully and keep it for future reference.

AIR COOLED CHILLER

MODEL

HEAT PUMP

R410A

5AC 020 CR / M5AC 020 CR

5AC 025 CR / M5AC 025 CR

WARNING

- Installation and maintenance should be performed by qualified person who are familiar with local code and regulation, and experienced with this type of appliance.

INDEX

- Outline And Dimensions	page i-ii	- Recommended Fuse And Cable Sizes	page 6
- Electrical Wiring Diagram	page iii	- Water Piping System Setup	page 7
- Isolator Diagram	page iv	- Refrigerant Circuit	page 7
- Transportation	page 1	- Special Precautions When Dealing With R410A Unit	page 7
- Installation Location	page 2	- Control Operation Guide	page 8
- Unit Installation	page 3	- Servicing And Maintenance	page 9
- Physical Data	page 4	- Troubleshooting	page 10
- Water Piping and Fitting	page 5	- Fan Speed Controller (Optional)	page 11
- Electrical And Wiring	page 5	- Isolator Switch Field Installation	page 11
- Electrical Data	page 5		

⚠ CAUTION

Please take note of the following important points when installing.

- **Do not install the unit where leakage of flammable gas may occur.**



If gas leaks and accumulates around the unit, it may cause fire ignition.

- **Do not overcharge the unit.**



This unit is factory pre-charged. Overcharge will cause over-current or damage to the compressor.

- **Sharp edges and aluminium fin coil surface are potential which may cause injury hazards. Avoid from being in contact with these locations.**



TRANSPORTATION

- Use spreader bars or forklift to lift the unit to avoid damage to the panels. Figure 1 provides the dimensions of the crate for lifting. Avoid violent movements. Do not remove crate until it is at its final location.

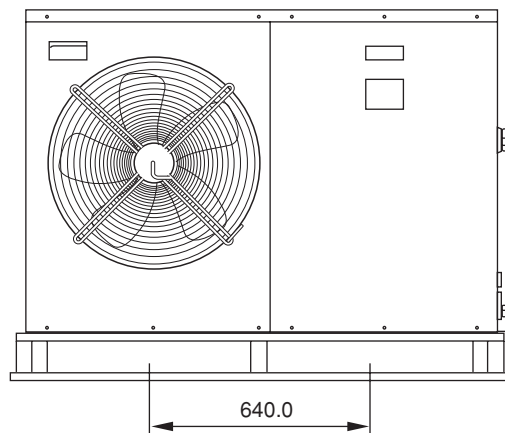

Figure 1

INSTALLATION LOCATION

- Installation work should be done by the authorized dealer or qualified contractor. Never install the unit yourself.
- Make sure there is sufficient space for airflow around the unit. The discharged air should be directed outside using a duct should the unit be installed in a plant room.
- Vibration isolator should be provided to prevent vibration and noise from the unit.
- When installing the unit on the ground, make sure the selected site is not subject to flooding.
- There should be sufficient space allocated for ventilation, servicing and maintenance when installing the unit. Refer to the following figures for proper location.

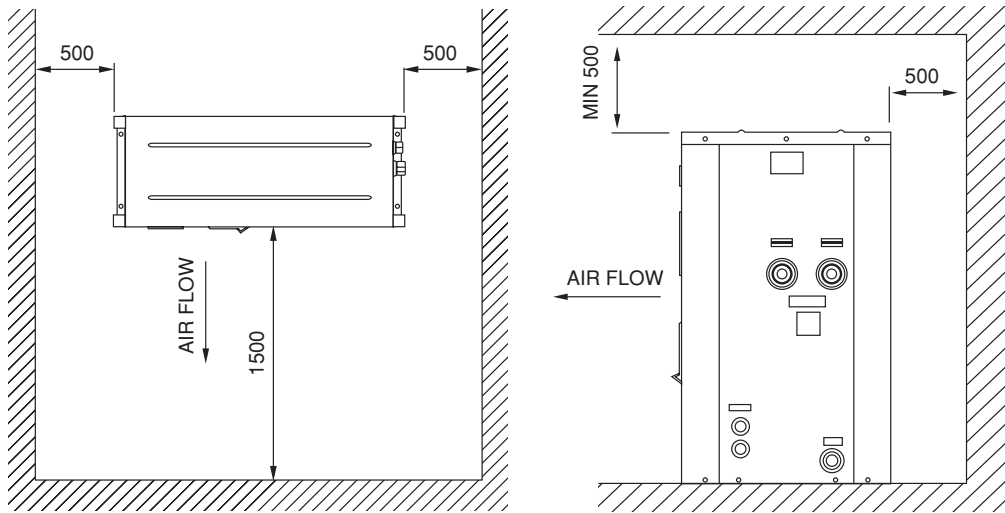

Figure 2: For single unit installation

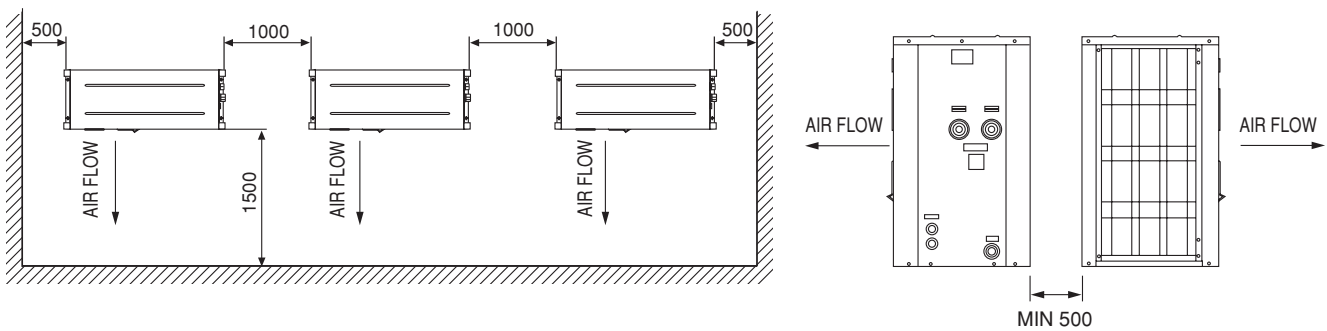

Figure 3: For multiple unit installation

- Unit subjects to floor installation must be placed on a concrete slab. The slab must have thickness of 100mm and 50mm wider and longer than the footprint of the unit (Figure 4). Place the concrete slab a distant from building to prevent vibration and noise.
- In the case of heatpump operation with an outdoor temperature below 0°C, the unit must be installed at least 300mm above ground level. This is necessary to prevent ice from accumulating on the frame and to permit proper operation in the event of heavy snowfalls.
- The unit must be leveled on both axes. (Tolerance is less than 2mm per meter.)

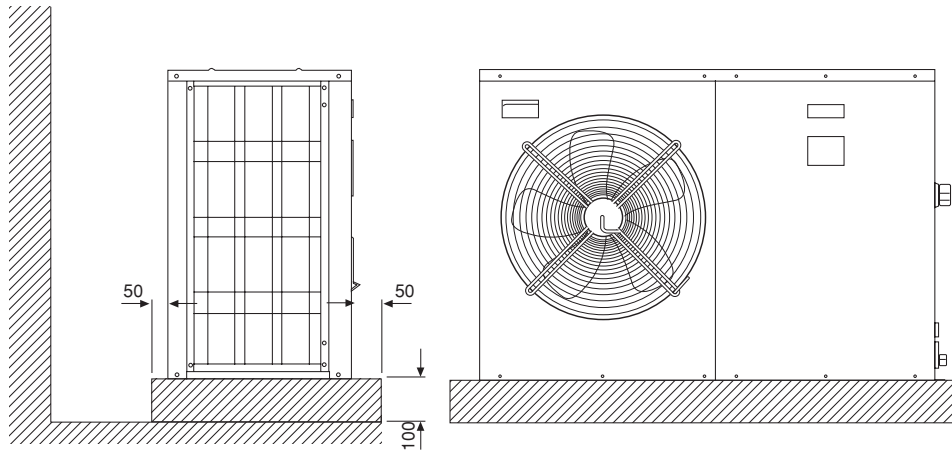
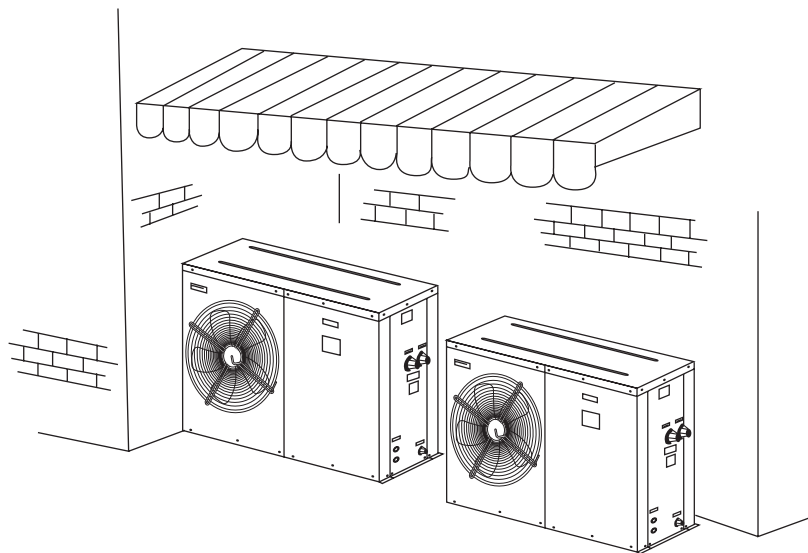

Figure 4: For floor installation

Note: All units are in mm unless specified.

UNIT INSTALLATION

5AC 020/025 CR



⚠ CAUTION

- Improper handling of unit during installation could result in leaks, electrical shock or unit malfunction.
- Contact your dealer for reinstallation or dismantling of unit.
- Do not introduce foreign objects such as fingers, sticks etc. into the air inlet and air outlet.
- Do not climb or place objects on top of mini chiller.

PHYSICAL DATA

Table A-1 : R410A - Heatpump

Model		5AC020CR	5AC025CR
Nominal cooling capacity	kW	4.98	6.15
Nominal heating capacity	kW	6.30	7.320
Operating Weight	kg	115.50	122.50
Refrigerant charge R410A	kg	1.20	1.725
Compressor		1 Rotary comp	
Control system		LCD Electronic Control	
Refrigerant - water heat exchanger		Braze Plate Heat Exchanger	
Water connections (BSP)	inches	1	1
Maximum water pressure	kPa	1000	1000
Hydronic circuit		High Head Circulator	
Pump		High Head Circulator	
Available pressure (Cooling / Heating)	kPa	87/68	163/93
Water inlet connection (BSPT)	inches	1	1
Water outlet connection (BSPT)	inches	1	1
Drain tap coupling (BSPT)	inches	1/2	1/2
Closed expansion tank water volume	litre	2	2
Refrigerant - air heat exchanger			
Tube diameter	mm	9.52	9.52
No. of rows		1	2
Tubes/row		30	30
Fin spacing	mm	1.27	1.59
O/D Fan			
Diameter	inches	18	18
No. of blades		5	5
Air flow (high speed)	m ³ /min	62.3	62.3
Fan speed (high speed)	r/min	910	920

Note: For cooling nominal values are based on 12°C / 7°C entering / leaving evaporator water temperature, 35°C air ambient temperature.
 For heating nominal values are based on 40°C / 45°C entering / leaving evaporator water temperature, 7°C/6°C (DB/WB) air ambient temperature.

WATER PIPING AND FITTING

- All water pipe must be adequately insulated to prevent capacity losses and condensation.
- Install a 40 to 60-mesh strainer to ensure good water quality.
- Water pipes recommended are black steel pipe and copper pipe.
- During installation, the piping of the unit should be clamped before rotating the installation pipe to reduce the moment induce on the piping.
- Users are recommended to install the pipes and accessories as shown in Figure 5.
- An air vent must be installed at the highest position, while a drainage plug at the lowest position of the water circuit. After the leak test (0.6MPa), open the air vent to release any air trapped in the water circuit.
- Run the clean water through the water inlet and operate the pump to drain out the dirty water. Clean the strainer after running the pump for 30 minutes.
- Fill up the water circuit after connecting the pipes and equipment. Check water leakage at all connections and joints. Do not start the unit when the system is leaking.
- To optimize the capacity of the system, ensure that the system is free of air bubbles. The air trapped in the system would make the system unbalanced.

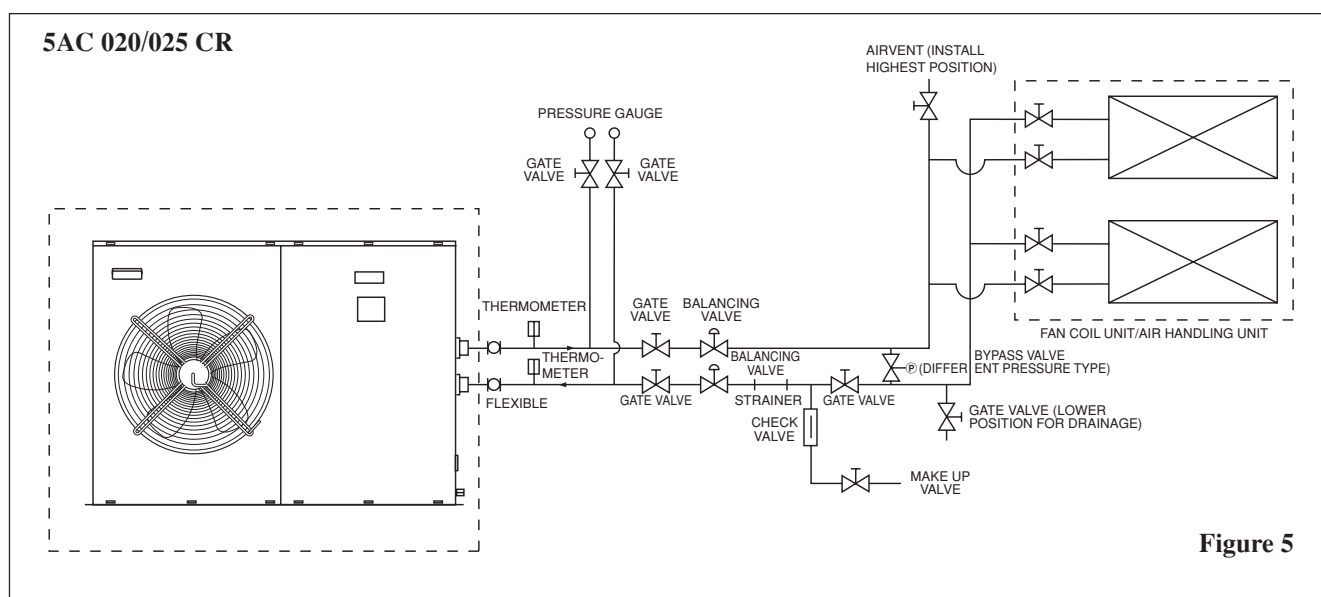

⚠ CAUTION

- Do not allow water to remain in the water pipes if the unit is not operating for a long period. Water must be drained out if the unit is not running during winter. Failing to do so would cause the pipe to crack.
- Do not drink the chilled water in the unit.

ELECTRICAL AND WIRING

- Refer to the wiring diagram provided on the unit when making electrical wiring.
- Do not ground any electrical equipment to the water piping.
- Install an external isolator switch (if it is not provided) to prevent electrical shock.

ELECTRICAL DATA

Table B-1 : (R410A - Heatpump)

Model		5AC020CR	5AC025CR
Power supply	V-ph-Hz	230 / 1 / 50	
Voltage range	V	220 - 240	
Nominal Power Input (Cooling/Heating)	kW	2.55/2.59	2.76/2.79
Nominal Current Input (Cooling/Heating)	A	11.9/12.1	12.7/12.9
Maximum Starting Current	A	67	68
Pump Power Input (Cooling/Heating)	W	185/193	195/209
Full Load Current (FLA)	A	14	15

RECOMMENDED FUSE AND CABLE SIZES

Cooling / Heat Pump

Model		5AC020CR	5AC025CR
Voltage Range **		220 ~ 240V /1Ph /50Hz + N + ⊕	
Recommended Fuse *	A	27	38
Power Supply Cable Size *	mm ²	10	10
Number of Conductor		3	3
Interconnection Cable Size *	mm ²	1.5	1.5

IMPORTANT : * The figures shown in the table are for information purpose only. They should be checked and selected to comply with the local/national codes of regulations. This is also subjected to the type of installation and conductors used.

** The appropriate voltage range should be checked with label data on the unit.

⚠ CAUTION

- All field wiring must be installed in accordance with the national wiring regulation.
- All the terminals and connections must be tightened. Improper connection and fastenings could cause electric shock, short circuit and fire.
- Ensure that the rated voltage of the unit corresponds to that of the name plate before commencing wiring work according to the wiring diagram.
- The unit must be GROUNDING to prevent possible hazards due to insulation failure.
- All electrical wiring must not touch the refrigerant piping, compressor, pump, fan motor or any moving parts of the fan motors.
- Do not operate the chiller with wet hands. It would result in electric shock.
- Do not use fuse of different amperage than stated. Using wire etc. to replace a fuse could cause equipment damage or fire.

5AC 020/025 CR Water / Refrigerant Circuit Diagram

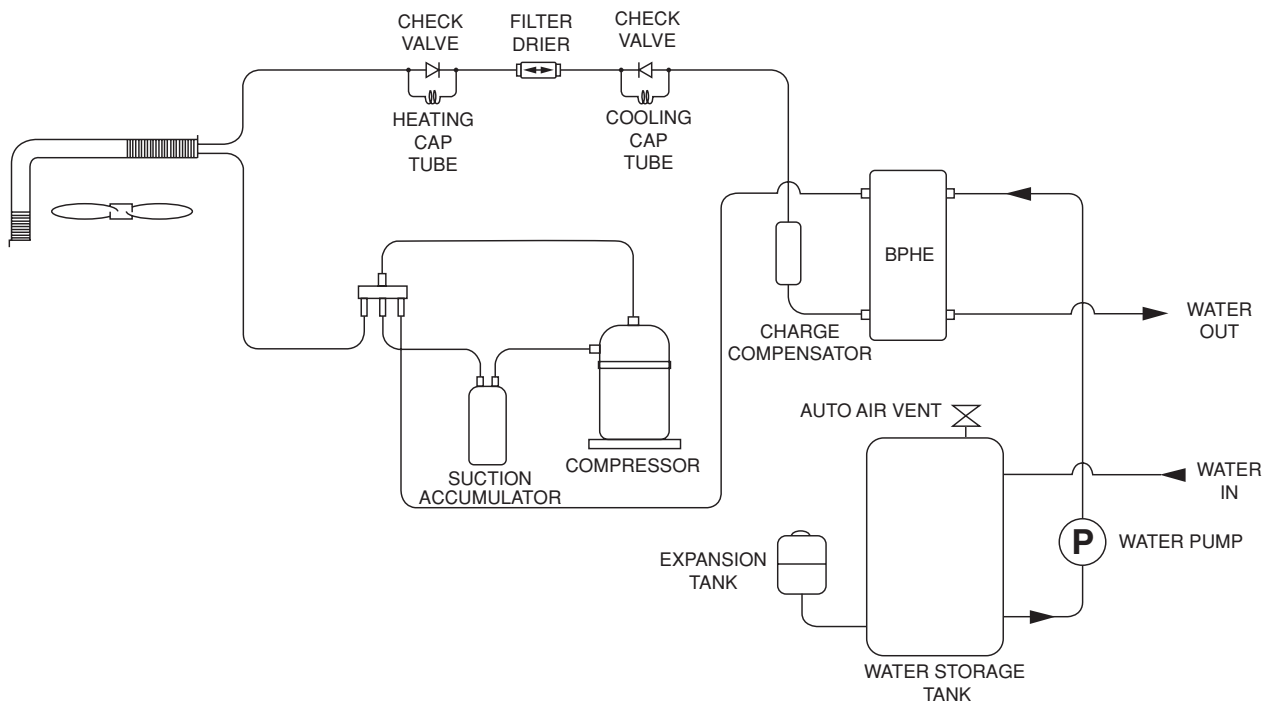

Figure 6

PART NO : 70-03-4-080547

WATER PIPING SYSTEM SETUP

- Fill up the water circuit after connecting all the pipes and equipment. Perform leak checks for all connections and joints. Do not start the unit when the system is leaking.
- To optimize the capacity of the system, ensure that the system is free of air bubbles. The air trapped in the system would make the system unbalanced.
- Ensure that the water tank is not full. This is to ensure optimal performance of the mini chiller. If the pressure is too high, release the pressure from the auto pressure relief valve on the tank.

REFRIGERANT CIRCUIT

- All chiller units are pre-charged with R410A refrigerant.

SPECIAL PRECAUTIONS WHEN DEALING WITH R410A UNIT

- R410A is a near azeotrope refrigerant blend of hydro fluorocarbon (HFC) which is environmental friendly. It has Zero Ozone Depletion Potential (ODP=0) and this conforms to Montreal Protocol regulations. It has no flame propagation and a low toxic refrigerant (rated as A1 by ARI). R410A is a mixture of R32 (50%) and R125 (50%).
- POE oil is used as lubricant for R410A compressor, which is different from the mineral oil used for R22 compressor. During installation or servicing, extra precaution must be taken not to expose the R410A system too long to moist air. Residual POE oil in the piping and components can absorb moisture from the air.
- Refrigerant R410A is more easily affected by dust or moisture compared with R22, make sure to temporarily cover the ends of the tubing prior to installation.
- No additional charge of compressor oil only is permitted.
- No refrigerant other than R410A is permitted.
- Tools designed specifically for R410A only.
 - i) Manifold gauge and charging hose
 - ii) Gas leak detector
 - iii) Refrigerant cylinder/charging cylinder
 - iv) Vacuum pump c/w adaptor
 - v) Flare tools
 - vi) Refrigerant recovery machine

CAUTION

- R410A must be charged as liquid. Usually R410A cylinder is equipped with a dip-pipe for liquid withdrawal. If there is no dip-pipe, the cylinder should be inverted so as to withdraw liquid R410A from the valve.
- Do not top-up when servicing leak, as this will reduce the unit performance. Vacuum the unit thoroughly and then charge the unit with fresh R410A according to the amount recommended in the specification.
- Do not touch the compressor or refrigerant piping when the chiller is running. If necessary wear protective gloves.

CONTROL OPERATION GUIDE

The unit is equipped with a microprocessor controller board. The microprocessor controller is provided to give temperature control for the system by accurately measuring and controlling the water entering and water leaving temperature. The temperature setting in the unit is preset in the factory. It is not recommended to change the setting unless necessary. A wired controller handset is connected to the microprocessor board. Every parameter setting and reading can be observed from the LCD of the handset.

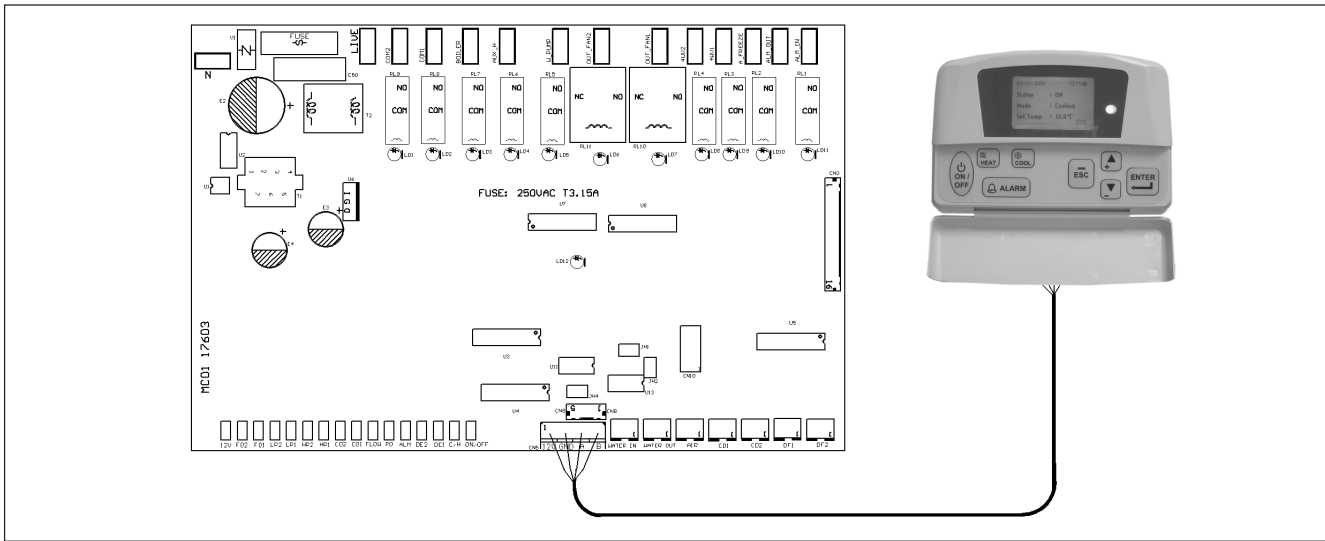

1. Handset location
The handset is located in the terminal box behind the service panel.
2. LED Display (microprocessor board)
The keypad LED will light up when the unit is powered up.
The LCD will light up when the unit is turned on.
3. LCD display (controller handset)
During normal operations, the LCD can display the entering water temperature, the leaving water temperature, the entering water setpoint temperature, compressor on or off status and outdoor air temperature. When malfunctioning occurred, the LCD would blink. The display would show the faulty parameter and the date and time of the occurrence.
4. Controller functioning specification
There is a 3 minute delay for the compressor and fan motor to restart (default setting).

⚠ CAUTION

- Use the controller handset to switch on / off the unit. Do not plug off the main power supply directly, it would cause the unit to breakdown.
- Do not change the settings of the safety devices.

SERVICING AND MAINTENANCE

- Servicing

Servicing or maintenance of these units must be carried out by experienced personnel with specific training in refrigeration. Repeatedly check the safety devices and continuous cycling of control components. These items must be analyzed and corrected before being reset.

The simple design of the refrigeration circuit totally eliminates potential problems during normal unit operation. No maintenance work is needed on the refrigeration circuit as long as the unit is operating normally.

Ease of maintenance has been taken into consideration during the design stage such that the unit is easily accessible from the service panels. The electrical components are especially easy to access since it is located in the terminal box in the front service panel (Figure 7).

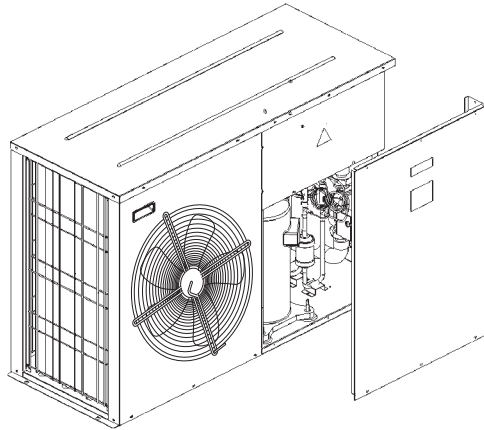

Figure 7

Under normal circumstances, these chillers required only a check and cleaning of air intake through the coil surface. These can be done monthly or quarterly depending on the surrounding where the units are installed.

When the surrounding is very oily or dusty, then the coils must be regularly cleaned by a qualified air condition service technician to ensure sufficient cooling capacity and efficient unit operation. The normal life span might be shortened if no proper service is provided.

- Maintenance

For consistent performance and durability, always conduct proper and regular maintenance to the unit.

For prolong period of operation time, the heat exchanger will become dirty impairing its effectiveness and reducing the performance of the units. Consult your local dealer about the cleaning of the heat exchanger.

No major maintenance or servicing is needed for the internal water circuit in the unit except the water pump failure. It is advisable to conduct regular check on the filter and change the water filter if it is dirty or choked.

Always check the water level in the system in order to protect the moving components in the hydraulic kit from over heating and excessive wear.

⚠ CAUTION

- Do not attempt to do any service or maintenance when the unit is operating.
- Do not spray any chemical agents or flammable agents to the unit. It could cause fire or explosion.

TROUBLESHOOTING

When any malfunction is occurred, immediately switch off the power supply to the unit, and contact the local dealer, if necessary. Some simple troubleshooting tips are given below :

SYMPTOMS	POSSIBLE CAUSES	REMEDIAL ACTION
1. Compressor does not start.	<ul style="list-style-type: none"> • No power supply. • Fuses blown or automatic circuit break-down open. • Defective contactor or coil. • Unit is stopped because safety device has tripped. • Loose wires. • Compressor faulty. 	<ul style="list-style-type: none"> • Check power supply. • Look for short circuit or grounded wires in motor windings. Replace fuses and reset circuit breakers when the fault has been corrected. Check tightness and soundness of all electrical connections. • Repair or replace. • Determine the type of safety shut down and correct the default before the unit is restarted. • Check wire connections and tighten terminal screws. • Contact local dealer.
2. Fan does not work.	<ul style="list-style-type: none"> • No power supply. • Fan motor faulty. 	<ul style="list-style-type: none"> • Check power supply. • Contact local dealer.
3. Unit does work, but insufficient cooling.	<ul style="list-style-type: none"> • Thermostat setting too high. • Condenser coil dirty. • Obstacle blocking air inlet or outlet of the unit. • Insufficient refrigerant in the system. • Improper water flow rate. • Water in the system is contaminated. 	<ul style="list-style-type: none"> • Reset thermostat. • Contact local dealer. • Remove the obstacle. • Contact local dealer. • Contact local dealer. • Contact local dealer.
4. Flow Switch Error	<ul style="list-style-type: none"> • No water in the system. • Low water level in the system. 	<ul style="list-style-type: none"> • Check water supply. • Check water supply.

CAUTION

- Troubleshooting must be performed by qualified personnel.

FAN SPEED CONTROLLER (OPTIONAL)

Operation of the mini chillers without any fan speed control is limited to an ambient temperature of 17°C. With the fan speed control, the units are able to operate down to -5°C. The fan speed controller **does not** come as a standard item in the mini chiller units. It is field-installed.

All mini chillers will have a 1/4" access valve provided for along the liquid line of the refrigerant circuit. This valve is for direct pressure connection to the fan speed controller.

To install the fan speed controller, screw in the female adaptor to the 1/4" access valve. Use a pair of spanners to tighten properly (max. torque 15 Nm). See Fig. 8. Ensure there is no leakage at the joint.

Wire the fan speed controller to the terminal blocks. See Fig. 9.

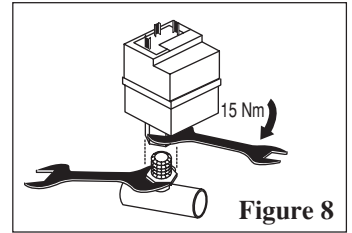

Figure 8

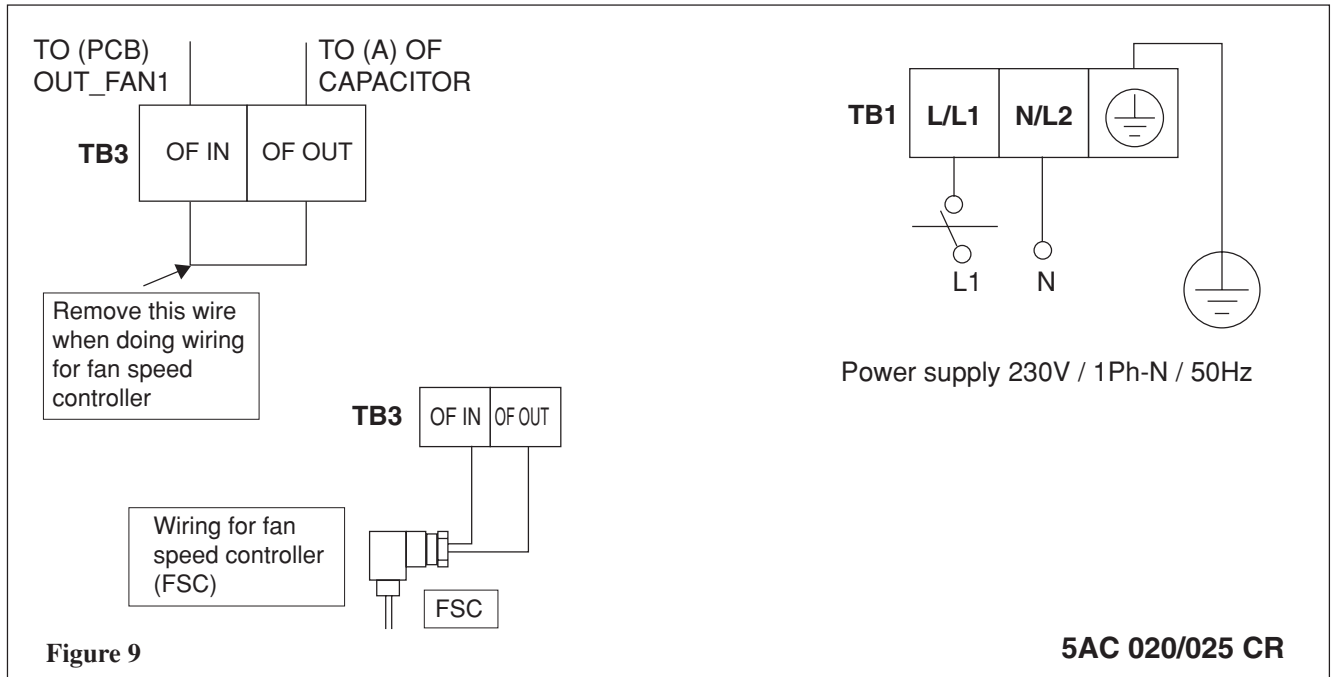

Figure 9

5AC 020/025 CR

ISOLATOR SWITCH FIELD INSTALLATION

The isolator switch does not come as standard item with the units. It is advisable to have it field installed. The isolator switch must be capable of making, carrying and breaking currents under normal circuit condition. It must be of AC23A duty and fully compliant to IEC: 947-3.

For isolator switch selection, check the starting and running consumption specified in Table B. Be sure to connect a ground wire from incoming power supply, either direct to the terminal box panel or use an auxiliary ground terminal in the isolator switch. To install an isolator switch, wire it to the terminal block as shown in the two figures in page iv.

- In the event that there is any conflict in the interpretation of this manual and any translation of the same in any language, the English version of this manual shall prevail.
- The manufacturer reserves the right to revise any of the specification and design contain herein at any time without prior notification.
- En cas de désaccord sur l'interprétation de ce manuel ou une de ses traductions, la version anglaise fera autorité.
- Le fabricant se réserve le droit de modifier à tout moment et sans préavis la conception et les caractéristiques techniques des appareils présentés dans ce manuel.
- Im Falle einer widersprüchlichen Auslegung der vorliegenden Anleitung bzw. einer ihrer Übersetzungen gilt die Ausführung in Englisch.
- Änderungen von Design und technischen Merkmalen der in dieser Anleitung beschriebenen Geräte bleiben dem Hersteller jederzeit vorbehalten.
- Nel caso ci fossero conflitti nell'interpretazione di questo manuale o delle sue stesse traduzioni in altre lingue, la versione in lingua inglese prevale.
- Il fabbricante mantiene il diritto di cambiare qualsiasi specificazione e disegno contenuti qui senza precedente notifica.
- En caso de conflicto en la interpretación de este manual, y en su traducción a cualquier idioma, prevalecerá la versión inglesa.
- El fabricante se reserva el derecho a modificar cualquiera de las especificaciones y diseños contenidos en el presente manual en cualquier momento y sin notificación previa.
- В случае противоречия перевода данного руководства с другими переводами одного и того же текста, английский вариант рассматривается как приоритетный.
- Завод-изготовитель оставляет за собой право изменять характеристики и конструкцию в любое время без предварительного уведомления.