

APX Series

Non-standby Power Supply

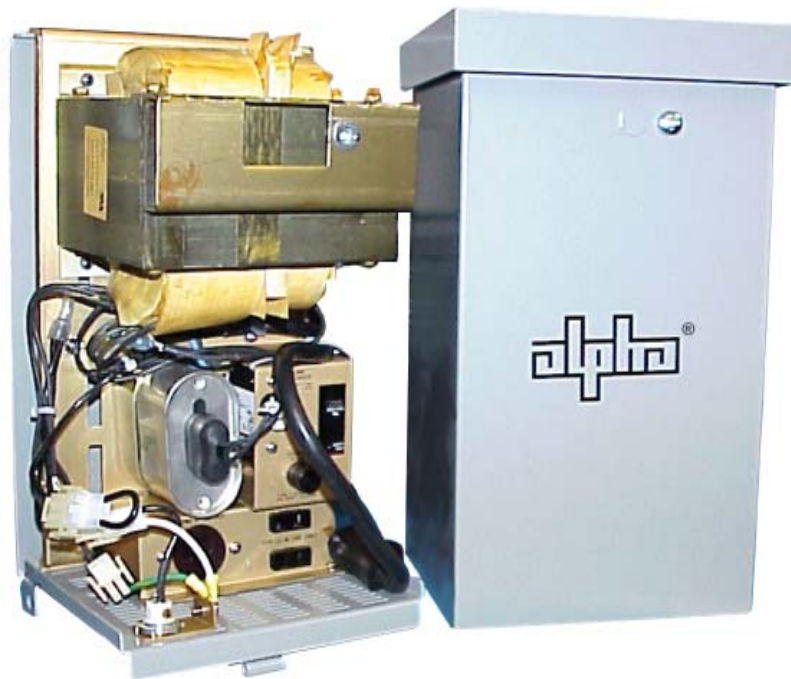

Power



APX Series Installation and Operation Manual

Effective: April 2006
Alpha Technologies

Power

Alpha Technologies 



APX Series

Non-standby Power Supply

016-030-B0-005, Rev C

Effective Date: April 2006
Copyright© 2006
Alpha Technologies, Inc.
A Member of the Alpha Group



NOTE:

Photographs contained in this manual are for illustrative purposes only. These photographs may not match your installation.



NOTE:

Operator is cautioned to review the drawings and illustrations contained in this manual before proceeding. If there are questions regarding the safe operation of this powering system, please contact Alpha Technologies or your nearest Alpha representative.



NOTE:

Alpha shall not be held liable for any damage or injury involving its enclosures, power supplies, generators, batteries, or other hardware if used or operated in any manner or subject to any condition not consistent with its intended purpose, or is installed or operated in an unapproved manner, or improperly maintained.

Contacting Alpha Technologies: *www.alpha.com*

or

For general product information and customer service (7 AM to 5 PM, Pacific Time), call

1-800-863-3930,

For complete technical support, call

1-800-863-3364

7 AM to 5 PM, Pacific Time or 24/7 emergency support

Table of Contents

Safety Notes.....	7
1.0 Introduction.....	8
1.1 Operating Principle	8
1.2 Standard Configurations	10
1.3 Optional Features	12
2.0 Installation.....	14
2.1 Pole Mount Installations.....	14
2.1.1 Wooden Poles.....	14
2.1.2 Concrete and Steel Poles	15
2.2 Wall Mount Installations	16
2.3 Pedestal Mount Installations.....	17
2.4 Rack Mount Installations.....	20
2.5 Shelf Mount Installations.....	23
2.6 Connecting Utility Power.....	24
2.6.1 Wiring the Enclosure Utility Service	24
2.7 External Service Disconnect.....	27
2.8 Modular Transformer Assembly (MTA)	29
2.9 AC Output Connection.....	31
2.10 Options.....	32
2.11 APX Output Voltage Reconfiguration.....	39
3.0 Operation.....	40
3.1 Start-up and Test.....	40
3.2 Shutdown and MTA Removal.....	41
4.0 Troubleshooting and Repair	42
4.1 Return Procedure.....	42
4.2 Replacement Parts	43
5.0 Specifications.....	44
5.1 APX Schematics	44
5.2 Specifications for APX.....	46

List of Figures

Fig. 1-1, Ferroresonant “Tank” Circuit and Resulting Output Waveform	9
Fig. 1-2, Pole Mount Enclosure	11
Fig. 1-3, APX Main Transformer Assembly.....	11
Fig. 1-4, The Alpha APX (PM) and Installable Options1	13
Fig. 2-1, APX Enclosure Pole Mounting	15
Fig. 2-2, Wall Mount Installation	16
Fig. 2-3, Stake Mounting Installed in PED.....	17
Fig. 2-4, PED Enclosure	18
Fig. 2-5, Soil-mount PED Enclosure Installed in Poured Concrete	18
Fig. 2-6, Concrete Pad Mounting.....	19
Fig. 2-7, APX Rack Mount (120VAC Version).....	20
Fig. 2-8, Option Placement and Power Connections.....	21
Fig. 2-9, APX-E Rack Mount (230VAC Version)	21
Fig. 2-10, Shelf Mount (SM)	22
Fig. 2-11, PED-M, PWE or UPE Enclosure Mounting	23
Fig. 2-12, PED-M, PWE or UPE Enclosure Mounting	23
Fig. 2-13, APX Bottom View	24
Fig. 2-14, 120VAC/60Hz Wiring.....	25
Fig. 2-15, APX 230VAC/50Hz Wiring.....	26
Fig. 2-16, Service Entrance/Meter Connections, 120VAC.....	28
Fig. 2-17, Service Entrance/Meter Connections, 240VAC.....	28
Fig. 2-18, MTA Mounted on Baseplate Assembly of PM Enclosure	30
Fig. 2-19, Universal Bracket for PED-mount	30
Fig. 2-20, Cable Connector/Output Port Assembly.....	31
Fig. 2-21, SIL-C Installed in Baseplate.....	32
Fig. 2-22, LA-M Inserted into Receptacle Box	33
Fig. 2-23, LA-P Inserted into Receptacle.....	33
Fig. 2-24, LA-E Option (230VAC models) Mount Under Receptacle Box.....	34
Fig. 2-25, LA-E Installation	35

List of Figures, continued

Fig. 2-26, AMM-C Ammeter Kit	36
Fig. 2-27, AMM-C Install Steps.....	36
Fig. 2-28, AMM-C Installation	37
Fig. 2-29, TDR-M Potentiometer	37
Fig. 2-30, TDR-M and ACAT-3P Options Installed in the APX.....	38
Fig. 2-31, ACAT-3P and TDR-M Installed in the APX Rack Mount.....	38
Fig. 3-1, APX Circuit Breaker and Fuse Location.....	40
Fig. 3-2, Shutdown and MTA Removal.....	41
Fig. 4-1, APX Schematic.....	44
Fig. 4-2, APX 90V Schematic	45

List of Tables

Table 1-1, Standard Features	10
Table 1-2, Optional Features	12
Table 2-1, High-Magnetic Breakers for Square D Service Entrances.....	27
Table 2-2, APX Output Voltage Reconfiguration.....	39
Table 4-1, Troubleshooting Guide.....	42
Table 4-2, Replacement Parts	43
Table 5-1, APX Series Specifications	46

Safety Notes

Review the drawings and illustrations contained in this manual before proceeding. If there are any questions regarding the safe installation or operation of the system, contact Alpha Technologies or the nearest Alpha representative. Save this document for future reference.

To reduce the risk of injury or death, and to ensure the continued safe operation of this product, the following symbols have been placed throughout this manual. Where these symbols appear, use extra care and attention.

ATTENTION:

The use of ATTENTION indicates specific regulatory/code requirements that may affect the placement of equipment and installation procedures.



NOTE:

A NOTE provides additional information to help complete a specific task or procedure.



CAUTION!

The use of CAUTION indicates safety information intended to PREVENT DAMAGE to material or equipment.



WARNING!

A WARNING presents safety information to PREVENT INJURY OR DEATH to the technician or user.

1.0 Introduction

The Alpha APX Series Non-standby Power Supply provides conditioned power to signal amplifiers in cable television and broadband distribution systems. The modular design, consisting of a baseplate, transformer assembly and enclosure cover, supplies the load with current-limited, regulated AC power, that is free from spikes, surges and other forms of power line transients. The design supports easy upgrades simply by replacing the transformer assembly, saving time and money.

Alpha's non-standby power supplies are extremely efficient, with a typical efficiency rating of 90% or better.

The versatile APX Series includes an AC input circuit breaker, output fuse, *output receptacle, VSF fitting, and external grounding clamp and can be mounted on poles, walls, racks, shelves, or pedestals. Operator controls are inside the enclosure on the main transformer assembly.

You can equip the APX with various options, including a *Time Delay Relay (TDR-M), Plug-in Lightning Arrestor (LA-M), Status Indicator LED (SIL-C), plug-in *Amp-Clamp (ACAT-3P), *Ammeter (AMM-C), and Enclosure Security Lock (GLK). See Section 1.3 for a complete description of all available options

1.1 Operating Principle

The Alpha Modular Transformer Assembly (MTA) contains the ferroresonant transformer, resonant circuit capacitor, and control panel with line input circuit breaker and output fuse assembly.

The Ferroresonant Transformer

Alpha APX Series uses ferroresonant transformer technology to provide line conditioning and voltage regulation. The primary and secondary windings of the transformer are physically isolated from each other by a large steel core which significantly reduces the capacitive coupling of spikes and noise to the secondary winding. This provides a regulated, current-limited output with excellent isolation and noise attenuation, (120dB common mode and 60dB transverse mode).

Another unique feature of the ferroresonant transformer is its ability to provide current limiting in the event of a short circuit. This effect is called foldback. The transformer's output current can typically reach 150% of the nameplate output current rating for a short period of time without damage to the transformer. When the transformer reaches the saturation point, the output current will decrease (foldback on itself) to a minimum value, and thereby provide current limiting. Designs based on ferroresonant transformer are extremely rugged and reliable offering many years of trouble-free operation.

The Resonant Circuit Capacitor

An oil-filled resonant AC capacitor is connected to the resonant (secondary) winding of the transformer forming a tank circuit. This provides the resonant circuit function which contributes to the voltage regulation of the supply. The advantage of this type of transformer/capacitor design is the ability of the ferroresonant transformer to regulate its output voltage over a wide range of input voltages and output loading. Typical output voltages may vary +/- 3% to 5%, with input voltages variations of +/- 15% of nominal line voltage, and output loading of 20% to 100%. This tight regulation is advantageous in cable television applications as the active devices are protected from dangerous voltages fluctuations.

1.0 Introduction, continued

1.1 Operating Principle, continued

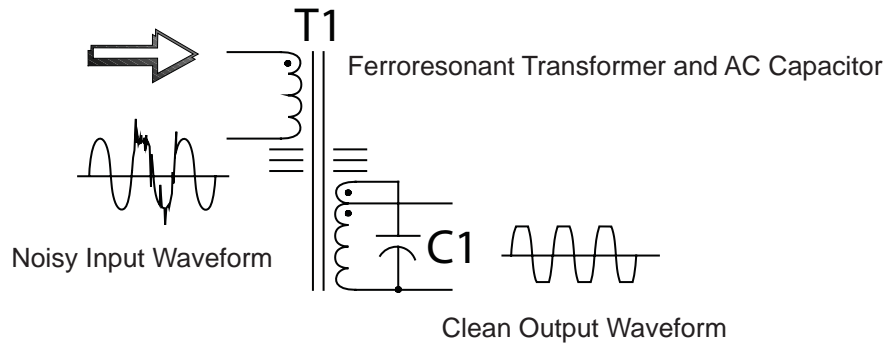

Fig. 1-1, Ferroresonant 'Tank' circuit and resulting output waveform

AC power enters the module where it is converted to a "quasi" square wave and regulated (at the required output voltage). It is then passed on to the load via the VSF fitting located on the baseplate assembly.

 **NOTE:**

A true RMS voltmeter must be used to correctly measure the output voltages.

1.0 Introduction, continued

1.2 Standard Configurations

The APX Series non-standby power supplies are available in the following configurations:

Available Configurations	Description
APX 6008	120VAC, 60Hz Input; 8A, 480VA, 60V Output; available in Pole, Rack, Wall, Shelf, or Pedestal Mount configurations. Includes: 8A thermal input circuit breaker, 120VAC output receptacle and 10A output fuse.
APX 6014	120VAC, 60Hz Input; 14A, 840VA, 60V Output; available in Pole, Rack, Wall, Shelf, or Pedestal Mount configurations. Includes: 12A thermal input circuit breaker, 120VAC output receptacle and 15A output fuse.
APX 6008 E	230VAC, 50Hz Input; 8A, 480VA, 60 or 48V Output; available in Pole, Rack, Wall, Shelf, or Pedestal Mount configurations. Includes: 8A thermal input circuit breaker, 230VAC output receptacle and 10A output fuse
APX 6014 E	230VAC, 50Hz Input; 14A, 840VA, 60 or 48V Output; available in Pole, Rack, Wall, Shelf, or Pedestal Mount configurations. Includes: 12A thermal input circuit breaker, 230VAC output receptacle and 15A output fuse.
APX 4808 E	230VAC, 50Hz Input; 8A, 384 VA, 48V Output; available in Pole, Rack, Wall, Shelf, or Pedestal Mount configurations. Includes: 8A thermal input circuit breaker, 230VAC output receptacle and 10A output fuse.
APX 6008 P	220VAC, 60Hz Input; 8A, 480VA, 60V Output; available in Pole, Rack, Wall, Shelf, or Pedestal Mount configurations. Includes: 8A thermal input circuit breaker, 120VAC output receptacle and 10A output fuse.
APX 6014 P	220VAC, 60Hz Input; 14A, 840VA, 60V Output; available in Pole, Rack, Wall, Shelf, or Pedestal Mount configurations. Includes: 12A thermal input circuit breaker, 120VAC output receptacle and 15A output fuse
APX 9015	120VAC, 60Hz Input; 15A, 60, 75 or 90V Output; available in Pole, Rack, Wall, Shelf, or Pedestal Mount configurations. Includes: 20A thermal input circuit breaker, 120VAC output receptacle and 20A output fuse
APX 9015	240VAC, 60Hz Input; 15A, 60, 75 or 90V Output; available in available in Pole, Rack, Wall, Shelf, or Pedestal Mount configurations. Includes: 10A thermal input circuit breaker, 240VAC output receptacle and 20A output fuse.

Table 1-1, Standard Configurations

1.0 Introduction, continued

1.2 Standard Configurations, continued

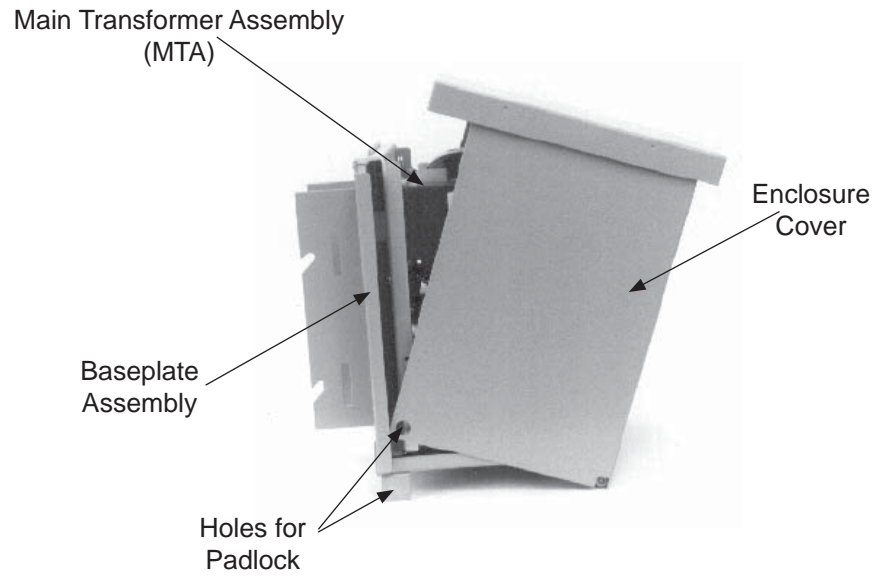

Fig. 1-2, Pole Mount Enclosure

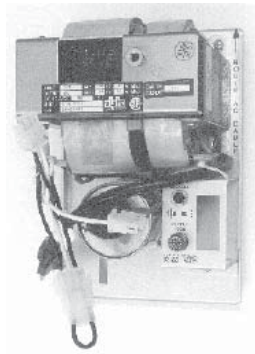

Fig. 1-3, APX Main Transformer Assembly

1.0 Introduction, continued

1.3 Optional Features

You can equip the APX Series with the following options. See Section 2.10, for installation instructions.

Option	Description	Part Number
GLK Enclosure Locks	Security lock for pole mount enclosures. PM models are equipped with a security hole to accommodate a standard padlock.	GLK-PED: 740-263-22; GLK-PM: 744-229-21
LA-M Plug-in Lightning Arrestor LA-E (230VAC)	The LA-M is a 350 joule, Metal Oxide Varistor (MOV) for primary site protection. It provides protection from voltage spikes caused by lightning and other disturbances. The LA-M is enclosed in plastic housing and plugs directly into a dedicated receptacle, eliminating the need for additional wiring. LA-E housed in an aluminum enclosure and must be hard wired into the APX.	LA-L120V: 744-173-20; LA-E240V: 744-174-20 LA-P+120V:020-098-24 LA-M120V: 020-116-21 (x2 for 240V)
SIL-C Status Indicator LED	Indicates that the APX is supplying AC output to the load and can be viewed from outside the enclosure. The light (red) remains ON as long as power is present at the modules output.	740-239-21
The following options are available for the APX Series power supplies <i>only</i>		
AMM-C Ammeter	Displays the output current to the load. It is also useful as a status indicator: a zero reading indicates no output current is being drawn by the load, a pegged meter indicates a short circuit condition in the plant.	10A : 740-238-21 15A : 740-238-22 15A: (9015 only) 744-594-20
TDR-M Plug-in Time Delay Relay	In the event of a AC utility line outage and subsequent voltage return, the TDR-M delays power to the output for 10 to 60 seconds, thereby providing time for the line voltage to stabilize and reducing possible noise spikes and other transients.	60V: 020-114-21 90V: 020-114-23
ACAT-3P Plug-in Amp Clamp	Protects active and passive equipment from voltage surges and transients. Provides "Crowbar" clamping protection from voltage spikes in excess of 104V. Consists of two rugged SCR's (silicon controlled rectifiers) connected in an inverse parallel configuration with a steady state current of 35A and a one cycle (8 ms) pulse rating of 500A. The SCR's are triggered into conduction whenever the Amp Clamp's bidirectional trigger diodes senses the presence of voltage transients exceeding 104-115V peak threshold. The fast response trigger circuit gates the appropriate SCR ON (in nanoseconds) to shunt the surge current to ground, effectively protecting sensitive equipment from transient overvoltage conditions.	60V: 020-115-21 90V: 020-115-23

Table 1-2, Optional Features

1.0 Introduction, continued

1.3 Optional Features, continued

See Table 1-1 for a complete description of these features.

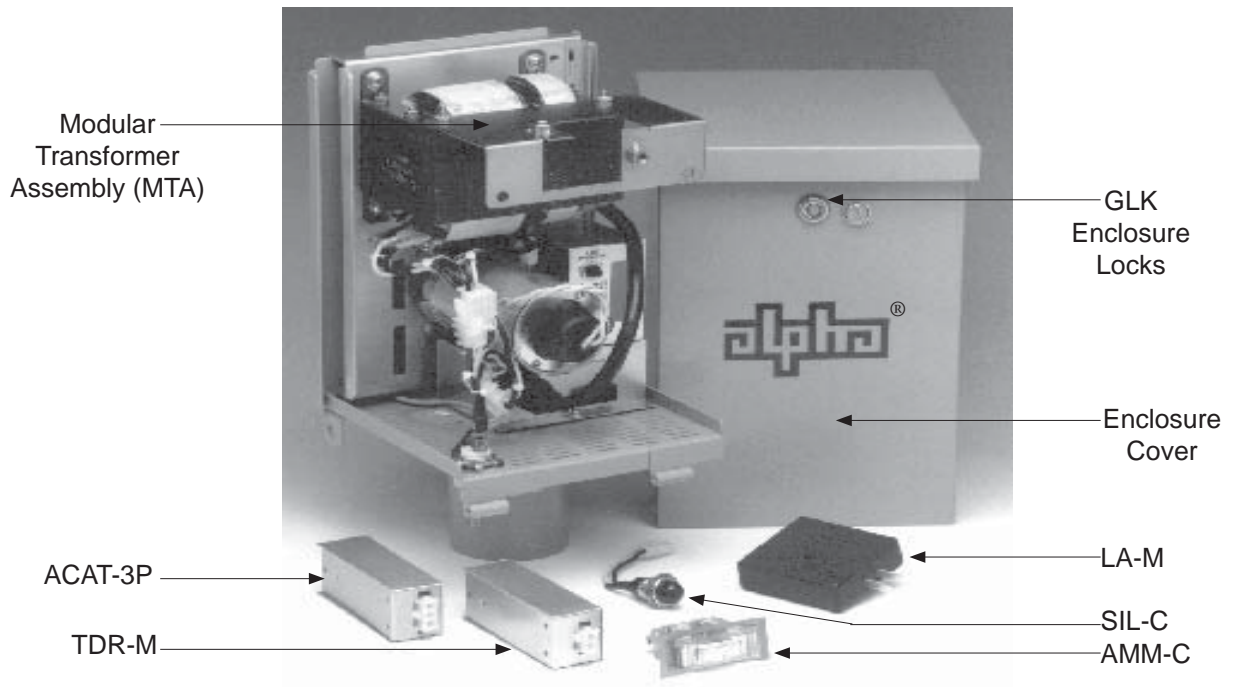

Fig. 1-4, The Alpha APX (PM) and Installable Options

2.0 Installation

2.1 Pole Mount Installations

The APX-PM can be mounted on wooden, steel, or concrete poles. Most local codes require that the base of the enclosure be at a minimum height from the ground. Always verify height restrictions before proceeding.



NOTE:

Poles are typically the property of the local utility. The utility must approve both the location and the method used to mount the APX before installation.



NOTE:

Before installing the MTA, verify that all options have been installed and properly connected.

2.1.1 Wooden Poles

For wooden poles, use mounting bolts that completely penetrate the pole.

Materials Required:

- Two (2) 5/8" diameter machine bolts (UNC thread) SAE Grade 5 or better, length to suit pole
- Four (4) 5/8" diameter zinc-plated flat washers
- Two (2) 5/8" diameter hex nuts (UNC thread)

Tools Required:

- Auger or drill for boring 3/4" diameter holes through the wooden pole
- Associated sockets or wrenches

Procedure:

1. Remove the APX from the shipping container and set the unit on its back (mounting bracket down).
2. Loosen the enclosure front panel hold-down screw and tilt the cover forward. Remove the cover by sliding it (at the hinges) to the right.
3. Loosen the captive screw at the bottom of the baseplate. Lift the Modular Transformer assembly up and off of the baseplate. Set the MTA aside.
4. Mark the position for the upper mounting bolt on the utility pole. Drill a 3/4" hole completely through the pole.
5. Using the baseplate as a template, align the upper hole in the baseplate with the upper hole in the utility pole. Verify that the spacing between the marks is 4 1/2" center to center. Drill the lower mounting hole.
6. Place a flat washer on each bolt and insert the mounting bolts through the baseplate assembly and pole.
7. Secure both bolts using a 5/8" washer and nut. Tighten nuts until the flanges on the baseplate mounting bracket dig into the wood approximately 1/4".
8. Install the Modular Transformer Assembly (MTA) onto the baseplate (see Section 2.8).

2.0 Installation, continued

2.1 Pole Mount Installations, continued

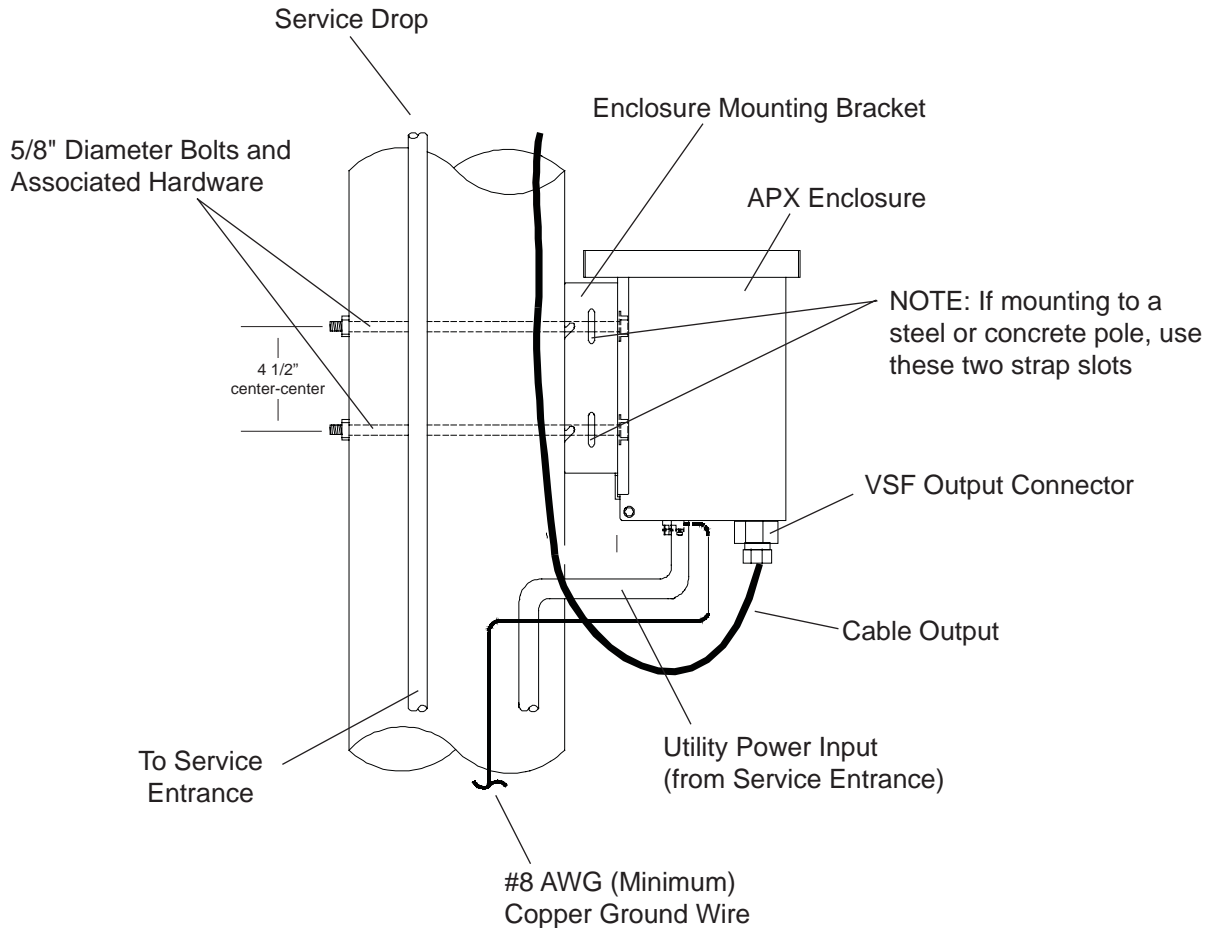

Fig. 2-1, APX Enclosure Pole Mounting

2.1.2 Concrete and Steel Poles

Materials Required:

Two (2) 1-1/2" approved mounting straps, length to suit pole.

Tools Required:

Assorted sockets or wrenches

Procedure:

1. Mark the position for the upper mounting strap on the utility pole.
2. Run two approved 1-1/2" mounting straps through the mounting bracket located on the back of the baseplate assembly.
3. Center the baseplate assembly on the pole and tighten the mounting straps.
4. Install the Modular Transformer Assembly (MTA) onto the baseplate (see Section 2.8 for details).

2.0 Installation, continued

2.2 Wall Mount Installations

The wall mount version is equipped with an adaptor bracket to ensure that the APX pole mount enclosure can be mounted on a flat, vertical surface. If the wall mount bracket cannot be installed on a flat, vertical surface and positioned over a wall stud (2x4; 2x6; etc), use appropriate anchors and lag bolts.



NOTE:

Install and connect all optional features before you install the MTA.

Procedure:

1. Mark the location of the wall mounting holes, using the bracket as a template. The distance between the holes is 4 1/2 inches center-to-center.
2. Drill the holes using a 1/4" drill bit. Mount the bracket to the wall using two 3/8" x 1 1/2" long steel lag bolts and washers. The 1/4-20 (Phillips) screw must be located in the upper right-hand side of the bracket before you secure it to the wall.
3. To mount the enclosure to the wall bracket, fit the slots (in the APX enclosure bracket) over the rivets in the wall bracket. The enclosure bracket fits over the outside of the wall bracket.
4. Tighten the screw located on the upper-right corner of the wall bracket using a #2 Phillips head screwdriver.
5. Install the Modular Transformer Assembly (MTA) onto the baseplate. See Section 2.8 for details.

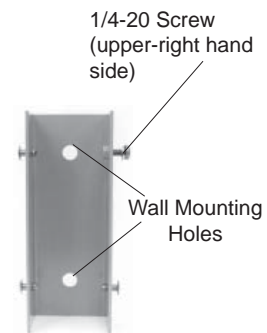

Step 1, Wall Bracket

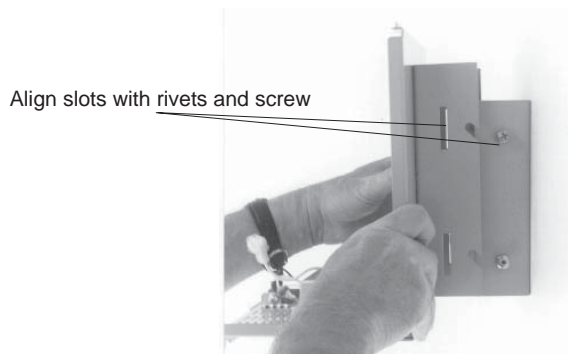

Step 2, Aligning slots

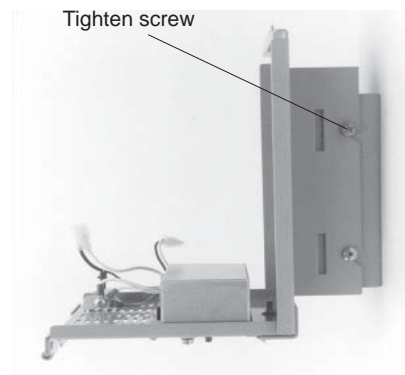

Step 3, Tighten screw

Fig. 2-2, Wall Mount Installation

2.0 Installation, continued

2.3 Pedestal Mount Installations

The pedestal mount (PED) is constructed of weather-resistant steel and is ideal for ground mount applications. The PED model is supplied with a stake for soil-mounting applications. An optional concrete mounting kit may be ordered for mounting to a concrete pad.



NOTE:

Before you install the MTA, first install and connect optional features.



NOTE:

Install the pedestal enclosure above the flood plane and locate it in an area safe from damage caused by traffic accidents, lawn equipment, or other hazards.



CAUTION!

When you sink the stake into the soil be extremely careful not to damage any underground cabling, utility wires, water or gas pipes. Your local utility company can tell you the location of these items.

Procedure: (Soil Mount)

Before proceeding, loosen the hex screw located on the right side of the enclosure. Lift off the hood and remove the MTA (if installed), and Universal Bracket (UB1) from the PED. The UB1 is secured by a wing-nut located near the top of the PED.

1. Locate the area to install the PED. Create a slight depression in the soil, 6" deep x 14" wide. This provides room to work while you are installing the PED, and additional security and stability.
2. Drive the mounting stake into the soil at the chosen location, leaving about 6" of the stake above the soil depression. The stake must be completely vertical.
3. Place the PED over the utility and cable feeds. Align two of the holes in the back of the enclosure with two holes in the stake. Secure the enclosure to the stake using the two bolts, washers and nuts provided.
4. Move soil around the outside of the enclosure to level the area. For additional stability, soil can be added inside of the enclosure to bring it level with the outside soil line.
5. Reinstall the UB1 Bracket and place the MTA on the bracket. Tighten the captive screw on the bottom of the UB1 to secure the MTA, (See Section 2.6 Connecting Utility Power, and 2.8 Modular Transformer Assembly).

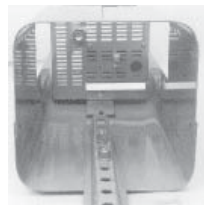

Fig. 2-3, Stake Mount
Installed in PED

2.0 Installation, continued

2.3 Pedestal Mount Installations, continued

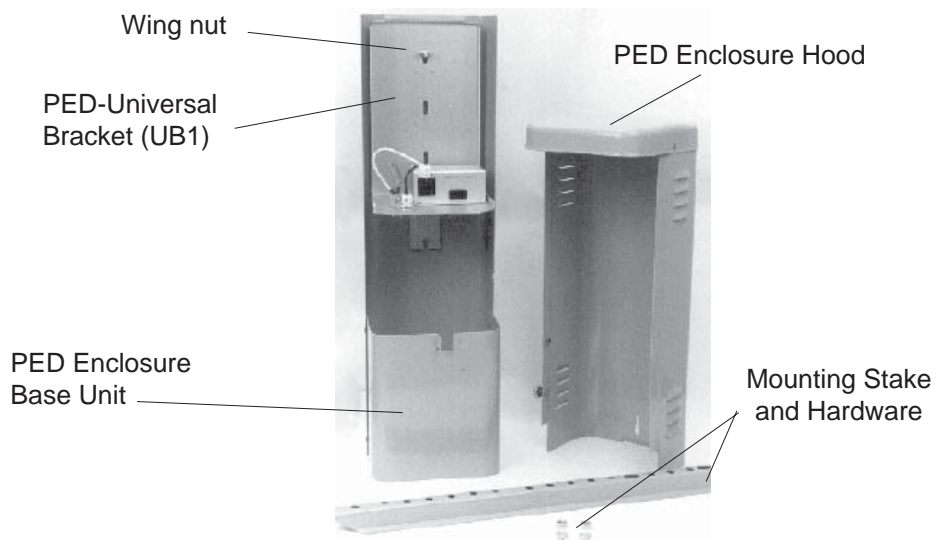

Fig. 2-4, PED Enclosure



NOTE:

If a more secure configuration is required, mount the enclosure level with the surrounding soil (with no depression), place a wooden form around the outside of the enclosure, and pour concrete to a depth of 3 or 4 inches.

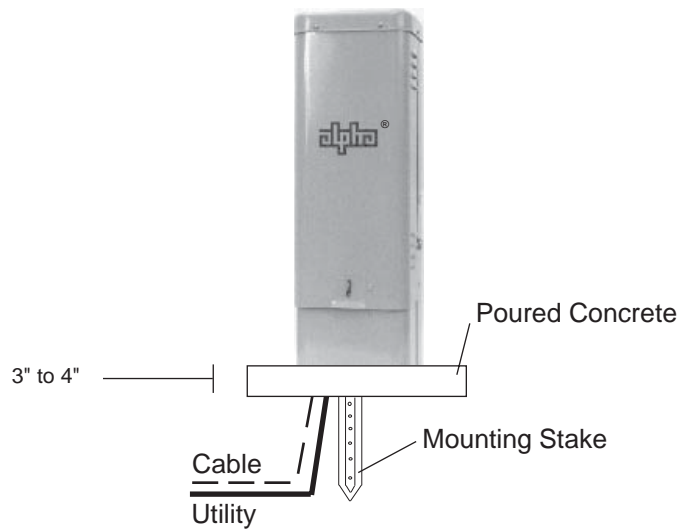

Fig. 2-5, Soil Mount PED Enclosure Installed in Poured Concrete

2.0 Installation, continued

2.3 Pedestal Mount Installations, continued

You can mount the PED enclosure to a concrete pad using the optional mounting bracket. The bracket mounts inside the rear of the enclosure using two hex bolts and washers. There are two 0.5" oblong mounting holes in the bracket to mount the enclosure to the concrete pad.

Place two (2) 3/8" J-bolts in the pad as specified and center two conduits (utility and cable output) in front of these bolts. If required, place an 8' dedicated ground rod near the utility conduit. To mount the enclosure to the pad, use a 3/8" lock washer and nut on each mounting bolt.



NOTE:

To prevent damage, you must mount the enclosure on a flush smooth surface. Do not over-torque. Alpha Technologies is not responsible for damages incurred to the enclosure by improper mounting on uneven surfaces.

Procedure: (Concrete Mount)

Before proceeding, remove both the MTA (if installed) and universal bracket (UB1) from the PED.

1. Install the concrete mounting bracket on the enclosure using the included bolts, washers and nuts. Insert the bolts from the outside of the enclosure.
2. Center the enclosure over the utility and cable conduits. Align the oblong holes in the mounting bracket with the 3/8" J-bolts. Secure the enclosure with a lock washer and nut.
3. Reinstall the UB1 bracket and place the MTA on the bracket. Tighten the captive screw on the bottom of the UB1 to secure the MTA (see Section 2.6 Connecting Utility Power, and 2.8 Modular Transformer Assembly).

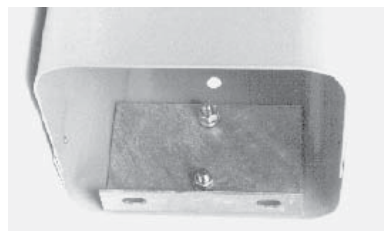
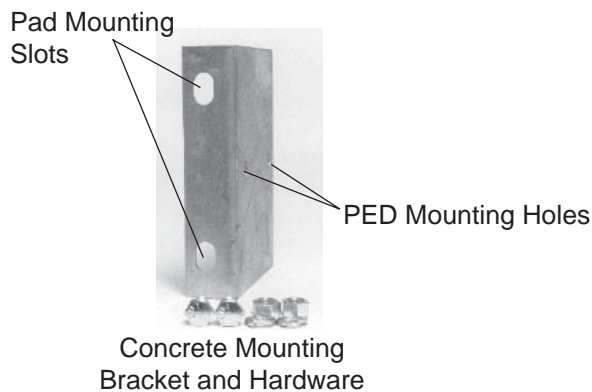

Concrete Mounting Bracket Installed in Unit

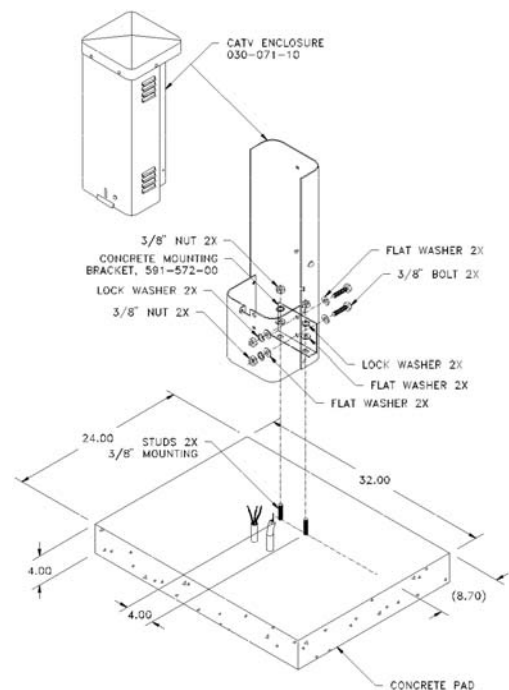

Fig. 2-6, Concrete Pad Mounting

2.0 Installation, continued

2.4 Rack Mount Installations

The APX is also available in a rack mount version that can be installed into a standard 19" rack.



NOTE:

Install and connect all optional features, before installing the MTA.

Procedure:

1. To mount the APX into a standard 19" rack, secure the APX to the rack rails, using 10-32 screws and cup washers (not supplied). To provide clearance when other equipment is installed in the rack, leave an inch above and below the 7" panel height.
2. The APX is supplied with an additional 3 three-foot (1.0m) power cord to connect the short cord on the rack mount APX to the standard receptacle box.
3. The APX is now ready for operation (see Section 3.1, Start-up and Test).

You can stack other APX power supplies in the same rack without additional clearance between the power supplies, as long as you leave sufficient clearance between the top and bottom supplies in the stack, adjacent equipment, and walls.

If you are using an enclosed rack or cabinet, leave at least 2" clearance between the transformer and surrounding wall panels, and provide ventilation through the use of louvered rear panels (or leave open if possible).

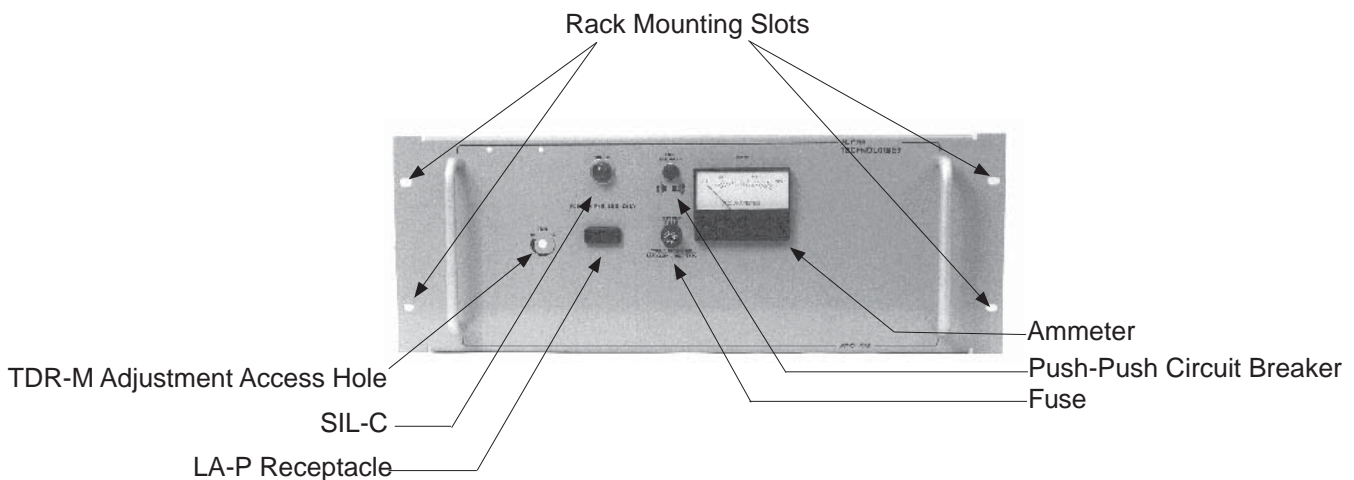

Fig. 2-7, APX Rack Mount (120VAC Version)

2.0 Installation, continued

2.4 Rack Mount Installations, continued

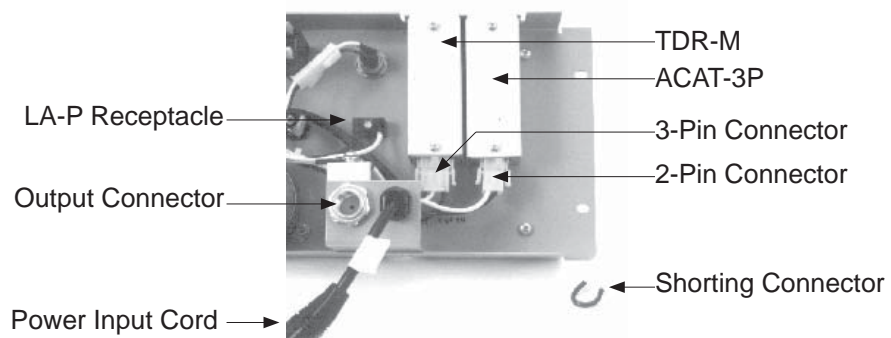

Fig. 2-8, Option Placement and Power Connections



Fig. 2-9, APX-E Rack Mount (230VAC Version)

2.0 Installation, continued

2.5 Shelf Mount Installations

The shelf mount version of the APX consists of the standard MTA (Modular Transformer Assembly) which rests on a mounting plate (SM). You can install the mounting plate and MTA into a number of Alpha enclosures, including the PED-M, PWE or UPE. The shelf mount option also includes an input AC power extension cable (APX model only) and an APX-SPI adaptor.

**NOTE:**

Before you install the MTA, first install and connect all optional features..

Procedure:

1. To place the modular transformer assembly (MTA) on the shelf mount (SM), fit the slot on the top of the MTA over the tab on the SM bracket.
2. Locate the captive screw on the opposite side of the shelf mount adaptor (next to the terminal block). Fit the captive screw into the threaded portion of the MTA and tighten.
3. Place the assembled shelf mount bracket and modular transformer assembly into the shelf of the enclosure (PED-M, PWE or UPE). Place one of the key-slot holes over the threaded screw hole in the enclosure shelf. Install a 8-32 x 1/2" long screw and tighten.
4. Connect the AC input power extension cable to the AC power cable on the unit. Connect the plug of the extension cable into the AC receptacle.
5. Output connection to the plant is accomplished via the terminal block or by using the APX- SPI adaptor cable.
6. The APX is now ready to connect to utility power via the terminal block on the MTA (see Section 3.1 Start-up and Test).

**NOTE:**

Only one screw hole is used to mount the SM to the enclosure shelf. To install additional APX-SM units in the enclosure, drill and tap another mounting hole.

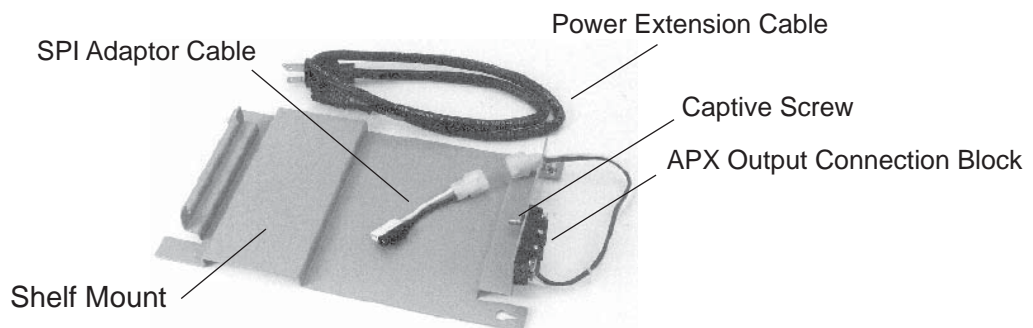

Fig. 2-10, Shelf Mount (SM)

2.0 Installation, continued

2.5 Shelf Mount Installations, continued

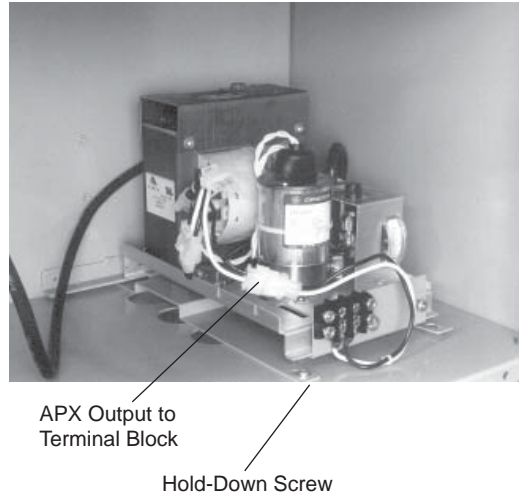

Fig. 2-11, PED-M, PWE or UPE Enclosure Mounting (using terminal block output)

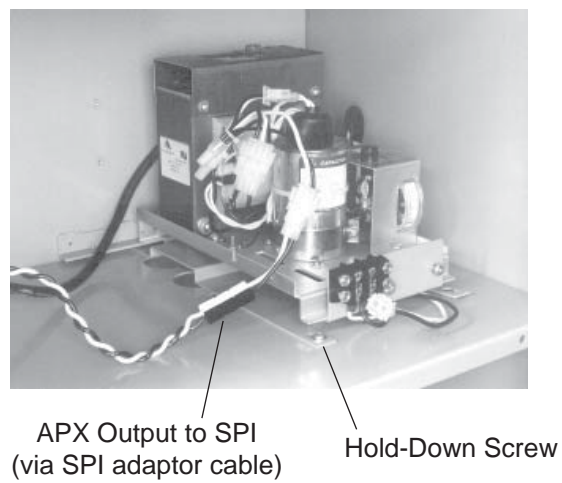

Fig. 2-12, PED-M, PWE or UPE Enclosure Mounting (using SPI output)

2.0 Installation, continued

2.6 Connecting Utility Power



CAUTION!

Contact your local utility for approval before you install the power supply and connect to utility power. All work should be performed by qualified service personnel in compliance with local electrical codes.



NOTE:

UL and NEC require the installer to connect a service disconnect switch (UL listed) between the power source and the Alpha power supply.

2.6.1 Wiring the Enclosure Utility Service

The following procedure does not apply to either the rack mount (RM) or shelf mount models (SM) which plug into a receptacle in the rack or enclosure.

Utility power enters the enclosure through a 7/8" diameter opening at the bottom of the APX enclosure. The enclosure accepts a standard conduit fitting. When used in conjunction with the PED-M metered, ground-mount enclosure, utility power enters through a dedicated raceway.

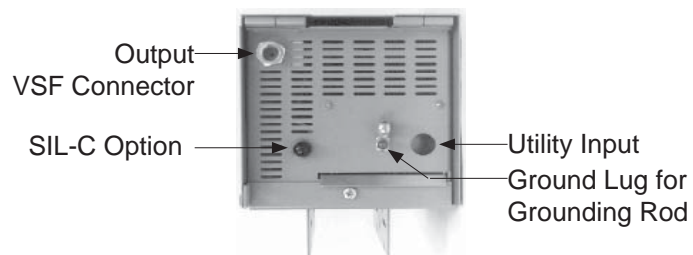

Fig. 2-13, APX Bottom View

2.0 Installation, continued

2.6 Connecting Utility Power, continued

2.6.1 Wiring the Enclosure Utility Service, continued



CAUTION!

Before you begin, turn off all utility power. Do not plug APX into AC receptacle at this time.

Procedure (120VAC, 60HZ):

1. If the Modular Transformer Assembly (MTA) is installed it must be completely removed during utility wiring. To remove the transformer assembly, loosen the captive screw on the bottom of the baseplate and lift.
2. Loosen the two captive screws securing the receptacle box. Turn the receptacle box over to expose the internal wiring.
3. Route the utility conduit through the 7/8" diameter opening located at the bottom of the APX. Secure the fitting with a locknut.
4. Connect the utility black (hot) wire (120VAC; 60Hz) to the black wire inside the receptacle box using the existing wire nut.
5. Connect the white (neutral) wire to the white wire inside the receptacle box using the existing wire nut.
6. Connect the utility green with yellow tracer ground wire to the grounding-wire-clamp on the baseplate and tighten the clamping screw. An external grounding clamp is also provided on the outside of the enclosure for connection to a ground-rod.
7. Reposition the rear tab on the receptacle box into the slot in the baseplate. Tighten the two captive screws.
8. Reinstall the MTA and tighten the screw.

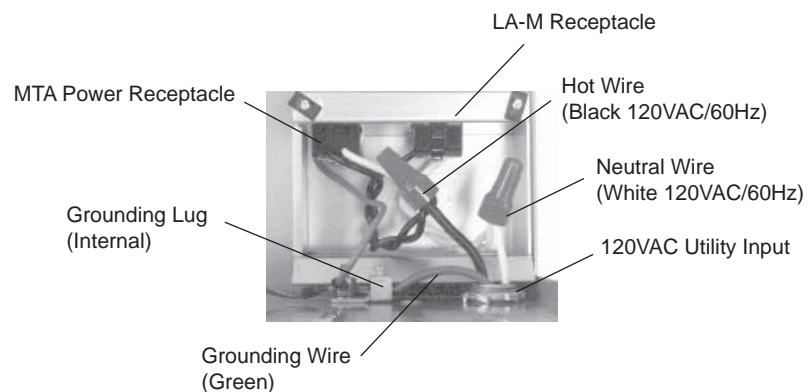

Fig. 2-14, 120VAC/60Hz Wiring

2.0 Installation, continued

2.6 Connecting Utility Power, continued

2.6.1 Wiring the Enclosure Utility Service, continued

Procedure (230VAC, 50 HZ):

1. If the MTA is installed, completely remove it prior to utility wiring. To remove the transformer assembly, loosen the captive screw on the bottom of the baseplate and lift.
2. Loosen the two captive screws securing the receptacle box. Turn receptacle box over to expose the internal wiring.
3. Route utility conduit through the 7/8" diameter opening at the bottom of the APX PM Enclosure. Secure the fitting with a lock nut.
4. Connect the utility brown-hot wire (230VAC; 50Hz) to the brown wire inside receptacle box using existing wire nut.
5. Connect blue-neutral wire to the blue wire inside the receptacle box using the existing wire nut.
6. Connect utility green/yellow tracer -ground wire to the grounding wire clamp on the baseplate. Tighten clamping screw. An external grounding clamp is also provided on the outside of the enclosure for connection to a ground-rod.
7. Reposition the rear tab on the receptacle box into the slot in the baseplate. Tighten the two captive screws.
8. Reinstall the MTA and tighten screw.

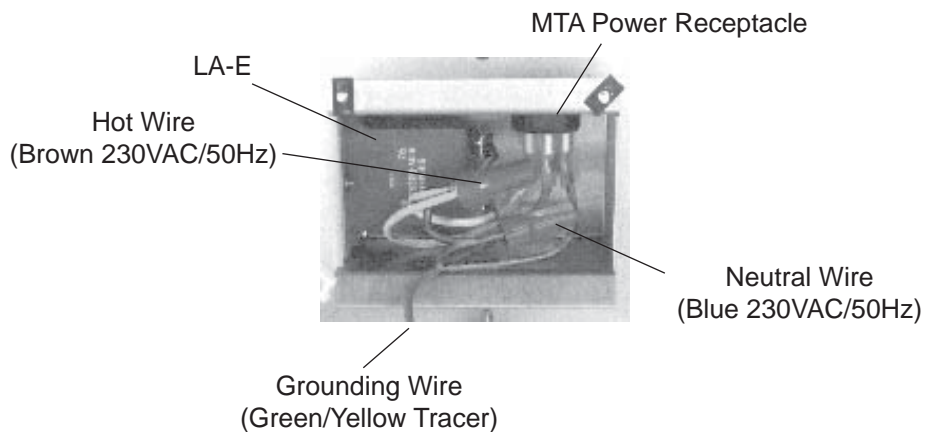

Fig. 2-15, APX 230VAC/50Hz Wiring

2.0 Installation, continued

2.7 External Service Disconnect

Position the external service disconnect between the utility power connection and the APX. For pole mount enclosures, attach it directly to the utility pole using 1/4" x 2-1/4" steel wood screws. If a utility power meter is being used, secure its mounting base in the same manner. Use a suitable conduit to interconnect the meter base, service disconnect, and power supply enclosure.

**NOTE:**

Use a high-magnetic 15A circuit breaker to accommodate the high inrush currents normally associated with the start-up of ferroresonant transformers (400A, no-trip, half cycle). Conventional service entrance breakers are not recommended.

High-magnetic breakers for Square D service entrances enclosures are available from Alpha Technologies:

Description	Alpha Part Number	Square D Part Number
Circuit Breaker	470-013-10	Q0115HM
Alpha BBX Option	020-085-10	Q02-4L70RB

Table 2-1, High-Magnetic Breaker for Square D Service Entrances

APX

- Connect the load side of the circuit breaker to the black wire from the APX receptacle box for 120VAC/60Hz operation (or brown wire for 230VAC/50Hz operation).
- Connect the neutral bus to the white wire from the APX receptacle box for 120VAC/60Hz operation (or blue wire for 230VAC/50Hz operation).
- Connect the utility ground to the enclosure ground terminal. See Figures 2-15 and 2-16.

2.0 Installation, continued

2.7 External Service Disconnect, continued



NOTE:

Service electric ground must be unbroken to service disconnect. All local utility and building codes apply.

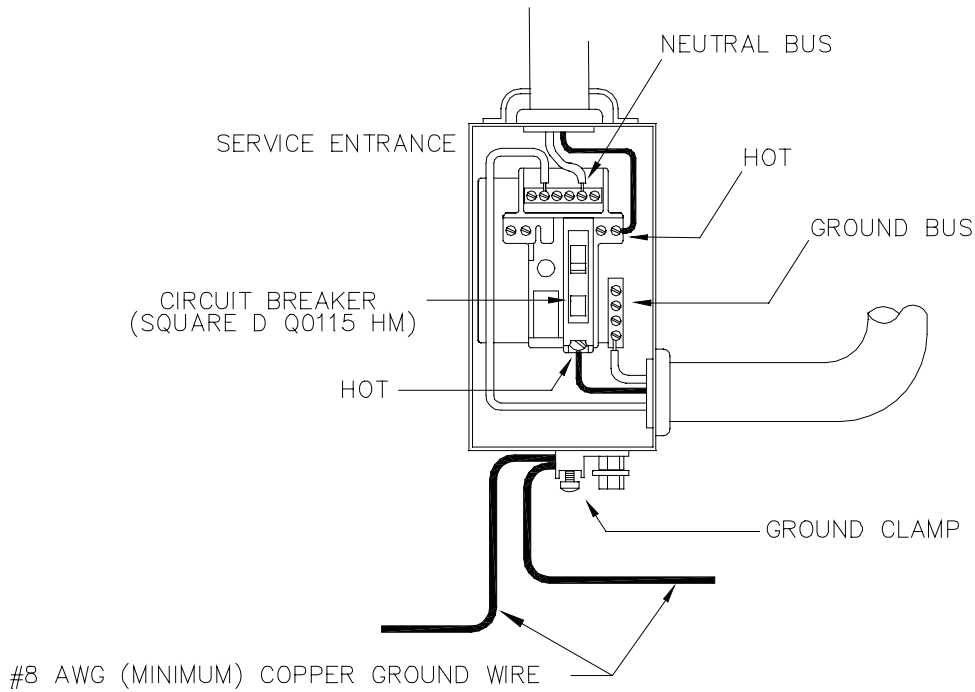

Fig. 2-16, Service Entrance / Meter Connections, 120VAC

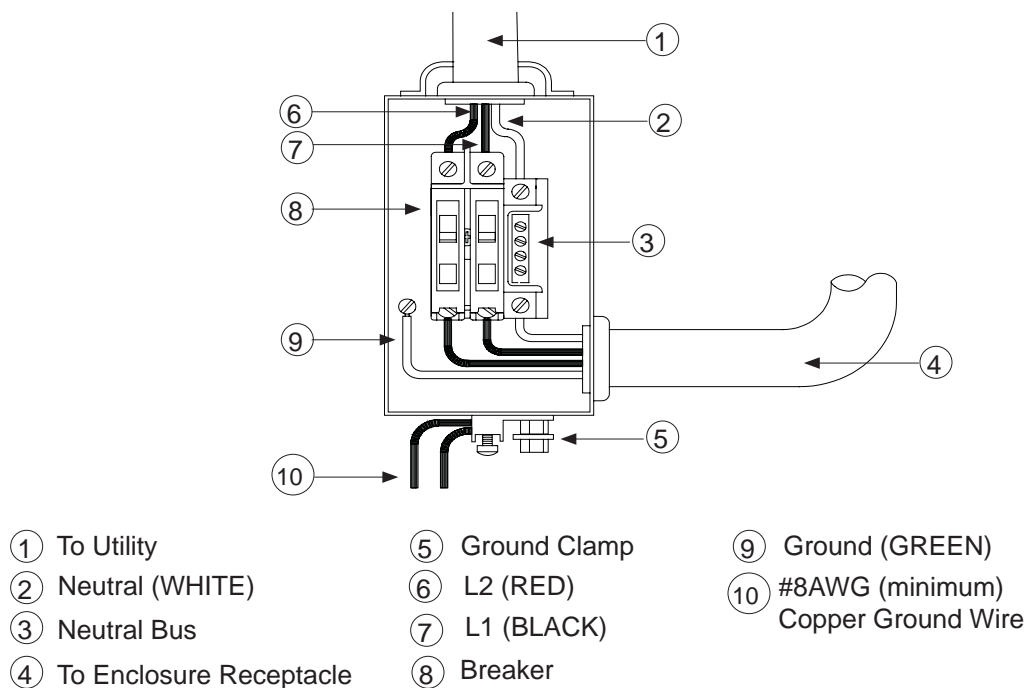

Fig. 2-17, Service Entrance / Meter Connections, 240VAC

2.0 Installation, continued

2.8 Modular Transformer Assembly (MTA)

The modular transformer assembly in the APX is designed for quick installation and removal. A captive screw in the baseplate secures the MTA into the enclosure.



NOTE:

Prior to installing the MTA, the enclosure must be mounted and utility and cable lines must be wired as previously described in this manual.

Pole and Wall Mount Procedure:

1. Place the MTA on the baseplate. Fit the tab on the top of the baseplate through the slot in the the MTA.
2. Secure the MTA by tightening the captive screw on the lower portion of the baseplate.
3. On the left side of the MTA, locate the white connectors attached to a black and white harness. The APX has two 2-pin and one 3-pin connectors.
4. Connect a free 2-pin connector to the output connector attached to the baseplate. The 3-pin connector contains a shorting plug for the TDR/M option. Do not remove the shorting plug.

Pedestal Mount (PED) Procedure:

The pedestal mount enclosure uses the same MTA as the pole mount units. The PED model uses the Universal Bracket 1 (UB1) instead of the baseplate. The UB1 has an additional mounting bracket.

1. Position the slot on the extended portion of the universal bracket over the stud located on the lower inside rear portion of the pedestal unit. Secure the top of the UB1 using the wing nut placed on the carriage bolt installed on the PED near the top of the enclosure.
2. Carefully slide the MTA downward on the Universal Bracket. The slot in the top of the MTA fits over the tab on the UB1.
3. Tighten the captive screw to secure the MTA to the lower portion of the universal bracket assembly.
4. Follow steps 3 and 4 in the pole mount and wall mount procedure (above).

2.0 Installation, continued

2.8 Modular Transformer Assembly (MTA), continued

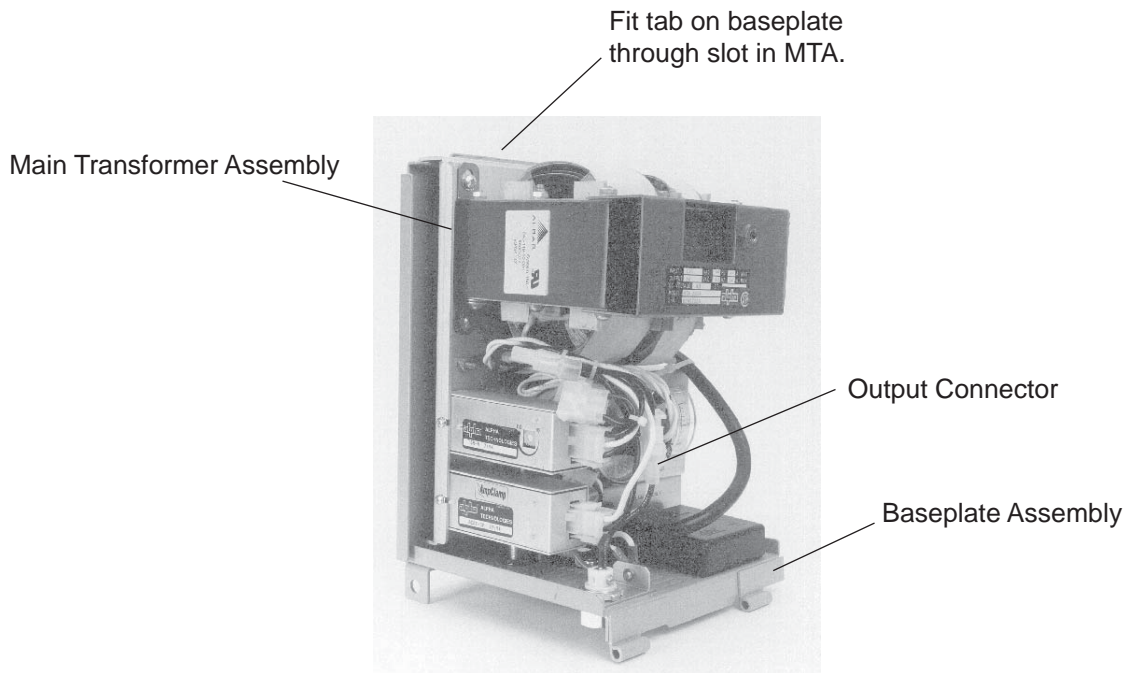

Fig. 2-18, MTA Mounted on Baseplate Assembly of PM Enclosure

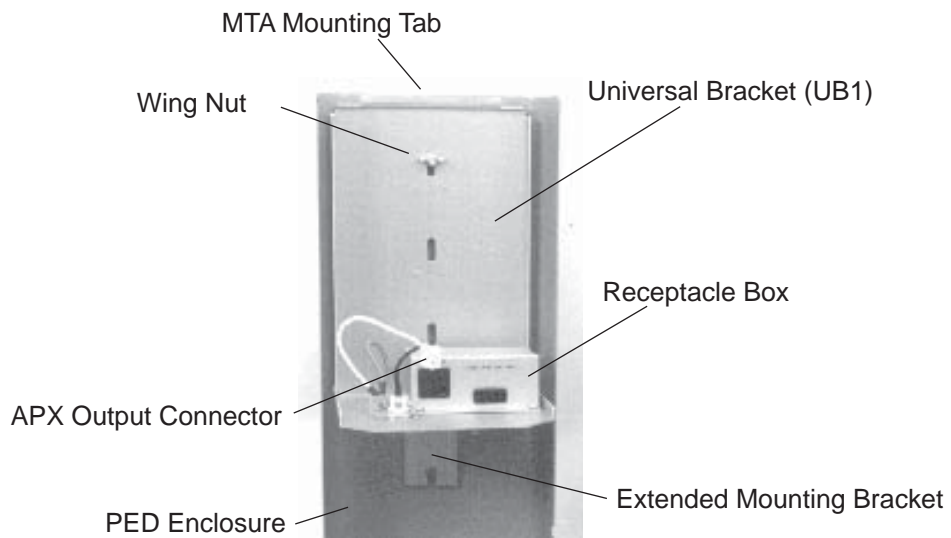

Fig. 2-19, Universal Bracket for PED Mount

2.0 Installation, continued

2.9 AC Output Connection

Procedure:

1. Prepare the incoming coaxial cable used for the distribution of power (including external fittings not supplied by Alpha).
2. Loosen the APX brass seizure screw output fitting to accommodate the center pin of the cable connector.
3. Screw the cable connector into the output port (large hex nut fitting) located on the baseplate of the APX. Place the center pin far enough into the fitting to secure the seizure assembly.
4. Tighten the brass seizure screw on the center pin. Loose connections can cause arcing and possible damage to the center conductor. During routine maintenance, always check the seizure screw assembly to ensure that it is tight.



NOTE:

For a flush fit, trim the center conductor. The length of the center conductor must be 1 1/4" from the end to the center of the O-Ring.

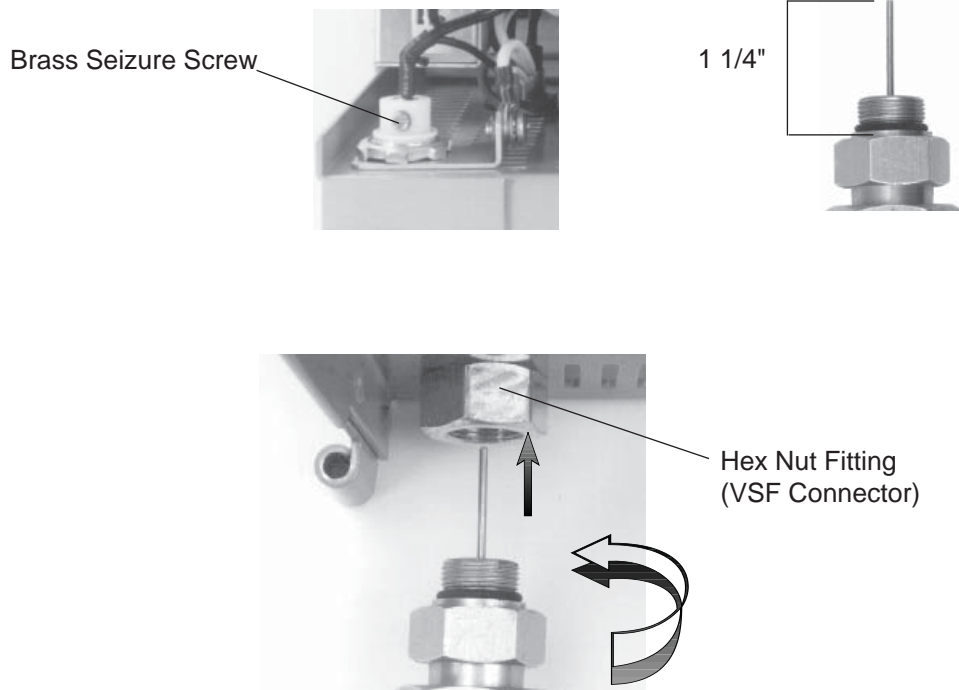

Fig. 2-20, Cable Connector/Output Port Assembly

2.0 Installation, continued

2.10 Options

Options for the APX can be installed easily in the field in a minimum amount of time.

See Section 1.3, Optional Features, for a complete list of available options.



CAUTION!

Always disconnect the power supply from the unit by unplugging the power cord before you install options.



NOTE:

All options ordered with the unit are installed by the factory. Use qualified service personnel to install additional options.

Status Indicator LED (SIL-C)

The Status Indicator LED (SIL-C) indicates AC output from the power supply during LINE operation.

Procedure:

1. Before installing the SIL-C, remove the knockout plug from the base of the enclosure, using a large flat-blade screwdriver.
2. Route the connector end of the SIL-C option up through the knockout hole and into the base of the enclosure.
3. Route the large star washer and nut over the SIL-C connector and wires. Screw the nut onto the threaded portion of the lamp base and tighten.
4. Connect the small 2-pin connector to its mating connector located in the enclosure base.
5. Apply power and test the lamp for proper operation.

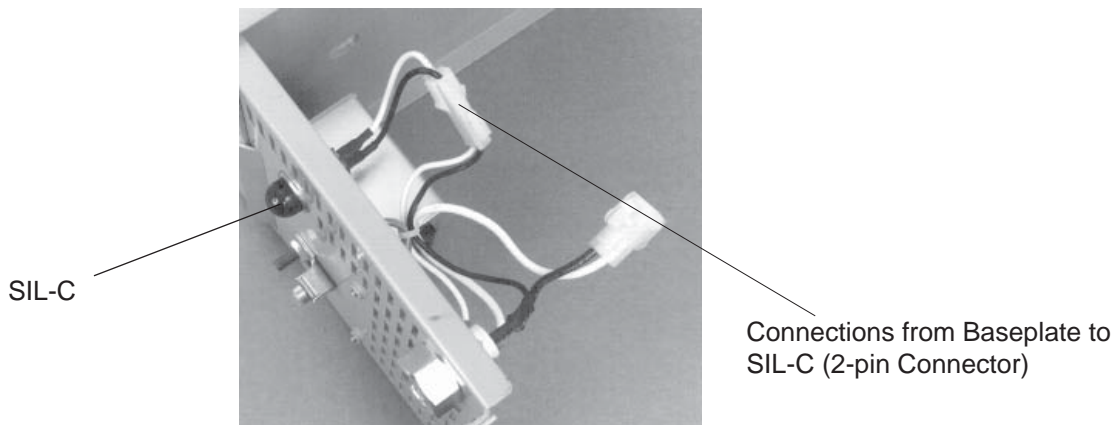

Fig. 2-21, SIL-C Installed in Baseplate

2.0 Installation, continued

2.10 Options, continued.

Lightning Arrestors

Lightning arrestors provide additional protection to sensitive electronic equipment from line disturbances caused by lightning strikes, surges, and spikes.

LA-M (Lightning Arrestor for the APX Series)

The LA-M requires no hard-wiring and plugs directly into the 2-pin receptacle to the right to the APX's power receptacle. Install the LA-M with the imprinted label up.



Fig. 2-22, LA-M Inserted into Receptacle
(PM and PED Models)

LA-P (Lightning Arrestor for 120VAC Rack Mount Models)

The LA-P version is electrically identical to the LA-M, but contains contact pins mounted in an "L" configuration. The LA-P is used in the APX Rack Mount model and simply plugs into the front panel of the APX Rack Mount. The LA-P can also be used in PED-M, and PWE enclosures using an available receptacle outlet.

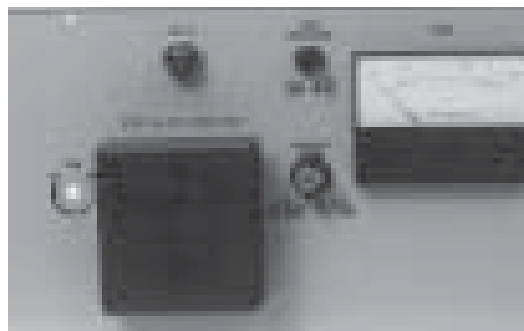

Fig. 2-23, LA-P Inserted into Receptacle
(Rack Mount Model)

2.0 Installation, continued

2.10 Options, continued.

LA-E (Lightning Arrestor for APX-E Version)

The LA-E lightning arrestor is hard-wired into the receptacle housing of the APX base unit. Install the device when initially wiring the APX to the 230VAC mains.



NOTE:

The APX-E receptacle box does not contain a separate receptacle for the LA-E.

Procedure, Wiring the LA-E lightning arrestor:

1. If the MTA is installed, remove it from the baseplate.
2. Remove the two screws from the front flange of the receptacle housing and lift it up to expose the wires underneath.
3. Remove the center screw from metal base of the LA-E option (if installed) and fit the LA-E into the left side of the receptacle housing. Replace the screw (removed in Step 2) from the outside of the receptacle housing and tighten.
4. Connect the brown wire from the LA-E to the brown (hot) wire in the receptacle box. This wire also connects to the brown (hot) wire from the utility. Use the existing wire nut to connect and secure the wires.
5. Connect the BLUE wire from the LA-E to the blue (neutral) wire in the receptacle box. This wire also connects to the blue (neutral) wire from the utility. Use the existing wire nut to connect and secure the wires.
6. If wiring to the utility at this time, follow steps 4 and 5 above. Reposition the receptacle box back onto the baseplate and replace the two screws.

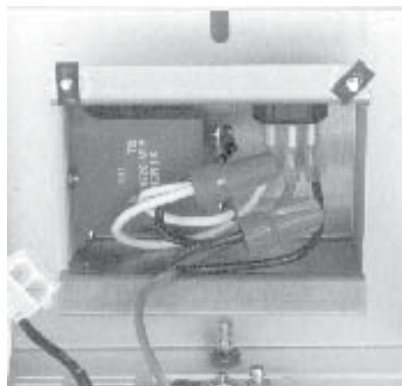

Fig. 2-24, LA-E Option (230VAC models)
Mounted Under Receptacle Box

2.0 Installation, continued

2.10 Options, continued.

LA-E (Lightning Arrester for 230VAC Rack Mount Models)

The LA-E lightning arrester mounts to the back of the front panel and is secured by the existing screw. This option must be hard-wired into the Rack Mount unit using quick-connect connectors.

1. Remove the wing nut from the screw on the LA-E mounting bracket. Position the LA-E and secure using the same screw.
2. Trim the wires supplied with the LA-E flush, leaving no copper wire exposed. Insert the trimmed end into the quick-splice connector until the end is flush with the internal wire stop. Fold this end of the connector shut and crimp tight using pliers. Repeat for additional wire.
3. Locate the blue wire from the AC power cord. Place into the open end of the quick-splice connector (connected to the blue wire on the LA-E), fold, and crimp.
4. Locate the brown wire from the AC power cord. Place it into the open end of the quick-splice connector (connected to the brown wire on the LA-E), fold, and crimp.

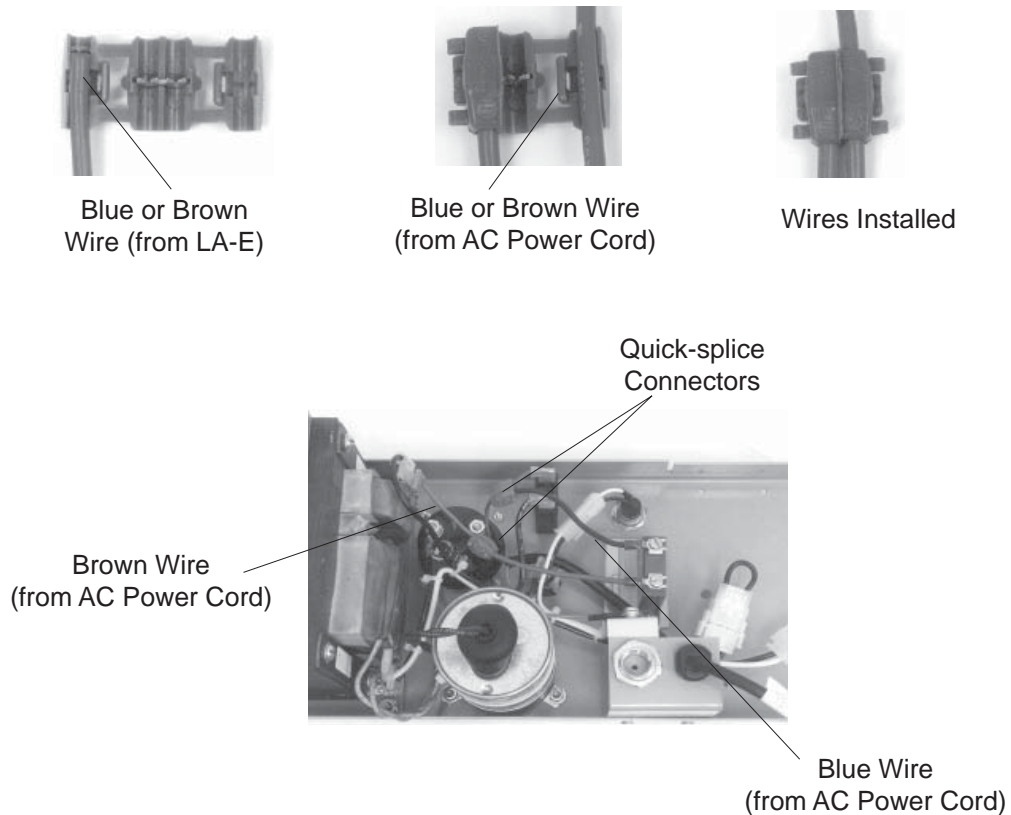

Fig. 2-25, LA-E installation

2.0 Installation, continued

2.10 Options, continued.

AMM-C (Ammeter)

The AMM-C Ammeter displays output current to the load and provides a visual indication of the load applied to the APX. You can also use the AMM-C to determine if an open or short circuit condition exists.

The AMM-C options consists of an ammeter, pressure mounting bracket, and an 8" connecting cable with spade-lug connectors.

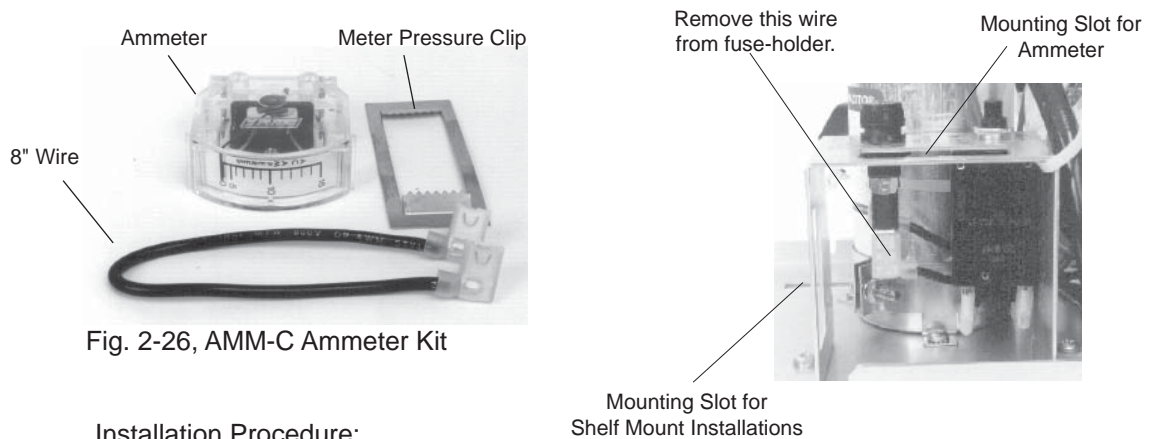

Fig. 2-26, AMM-C Ammeter Kit

Installation Procedure:

The AMM-C Ammeter is placed in series with the transformer (Tab #4) and output fuse. Before installing the ammeter, disconnect the black wire connected to the rear-most section of the fuse holder (the other end of this wire is connected to Tab #4 on the transformer).

1. Insert the AMM-C partially into the slot on the fuse / meter bracket, making sure that the 0-Amp reading is at the bottom. *For shelf mount installations, use slot shown.*
2. Partially place the meter pressure clip so it just catches the meter. Keep the AMM-C free to easily reach the wire connections. The teeth on the pressure clip should face the rear of the ammeter.
3. Connect the wire removed in step 1 to the upper terminal of the AMM-C.
4. Connect the 8" wire to the rear-most terminal on the fuse holder. Connect the other end to the lower terminal on the AMM-C.
5. Fully insert the AMM-C into the slot and slide the pressure clip completely forward until it contacts the underside of the fuse/meter bracket.
6. Reconnect the APX to line power and test the AMM-C for proper operation.

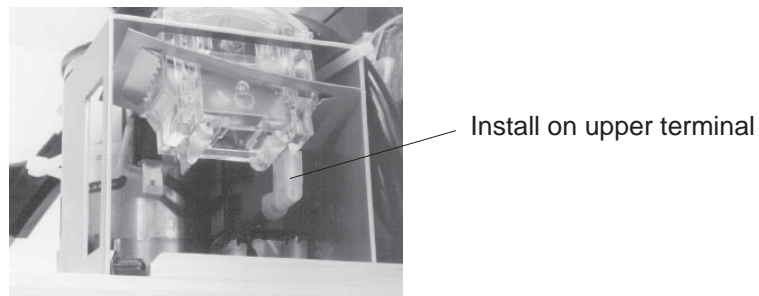

Fig. 2-27, AMM-C Install Steps

2.0 Installation, continued

2.10 Options, continued.

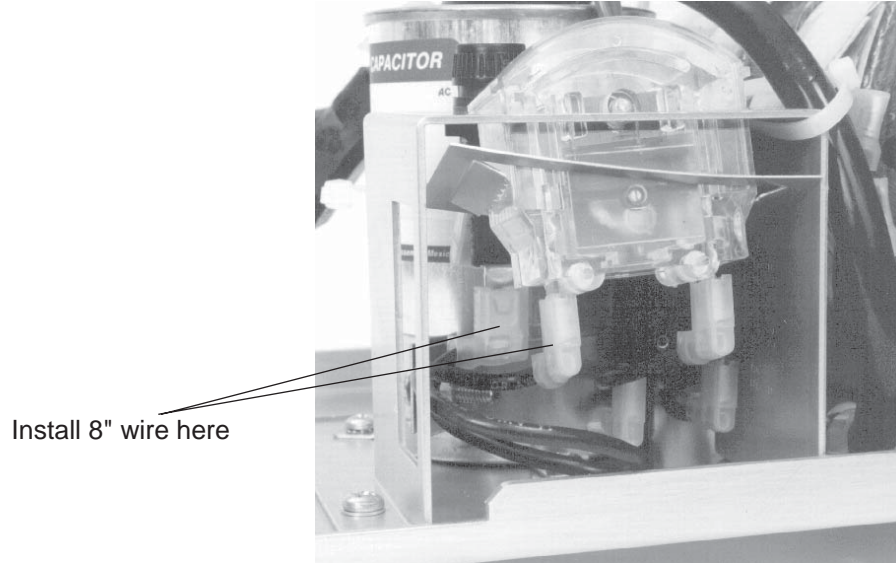

Fig. 2-28, AMM-C Installation

TDR-M (Plug-in Time Delay Relay)

The TDR-M briefly delays power to the output during utility start-ups (after an outage has occurred). With the easily accessible potentiometer, you can vary the delay time between 10 and 60 seconds.

TDR-M Installation Procedure:

1. Remove the single SEMS screw from the text side of the TDR-M (if installed).
2. Place the tab on the TDR-M into the upper slot (adjacent to the capacitor).
3. Slide the TDR-M toward the left side until flush with the left flange on the APX. Align the slot in the flange with the screw hole in the TDR-M.
4. Replace and tighten the screw.
5. Disconnect the shorting plug from the 3-pin connector. Save the shorting plug; if the TDR-M is removed, it must be reinstalled. Plug the 3-pin connector into its mating connector on the TDR-M.
6. Connect a true reading RMS digital multimeter to the output of the APX. Apply power to the APX and adjust the potentiometer for the desired output delay time using the digital multimeter.

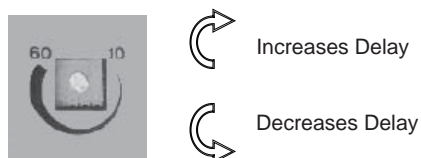

Fig. 2-29, TDR-M Potentiometer

2.0 Installation, continued

2.10 Options, continued.

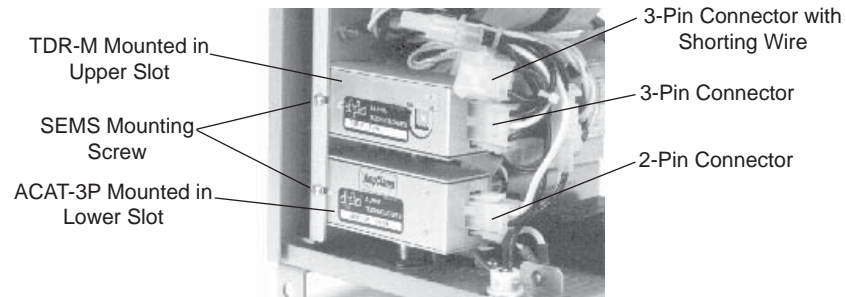

Fig. 2-30, TDR-M and ACAT-3P Options Installed in the APX

ACAT-3P (AMP Clamp)

The ACAT-3P clamps dangerous spikes and surges to ground protecting sensitive electronic equipment.

ACAT-3P Installation Procedure:

The procedure for mounting the ACAT-3P is the same as that for the TDR-M. However, the ACAT-3P mounts in the lower slot and connects to the 2-pin connector. See Fig. 2-30.

ACAT-3P and TDR-M Options for Rack Mount Models

Both of these options are available for the APX.

Installation Procedure:

1. Mount these options on the rear of the unit and secure with one SEMS screw. The screw is inserted from the front panel of the APX.
2. Connect the proper connector into the option. If you are installing a TDR-M, first remove the 3-pin shorting connector.

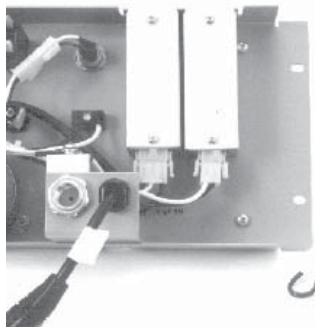

Fig. 2-31, ACAT-3P and TDR-M Installed in the APX Rack Mount

2.0 Installation, continued

2.11 APX Output Voltage Reconfiguration

The APX 90V series has a user-selectable output voltage between 60VAC, 75VAC, and 90VAC. Verify appropriate output voltage selection for each application. The default setting is 90VAC.

To reconfigure the output voltage, move the 12-gauge black wire to the appropriate output tap on the transformer. See Table 2-2.



NOTE:

If the SIL-C option is installed, the 20-gauge black wire connected to the SIL-C must remain connected to the 60VAC (tap 6A) output tap.

Black Wire	White Wire
90VAC / 6C	5
75VAC / 6B	5
60VAC / 6A	5

Table 2-2, APX Output Voltage Reconfiguration

3.0 Operation

3.1 Start-up and Test

After all utility and cable connections are complete, test the APX before placing it into service.

Test Procedure:

1. Before you apply power, verify that the AC LINE circuit breaker is in the OUT (off) position. The white portion of the stem will be visible. If it is not, press the breaker button.
2. Plug the APX power plug into the receptacle provided in the internal AC receptacle box.
3. If the APX is equipped with a LA-M (or LA-P) Plug-in MOV, plug it into the designated receptacle.
4. Switch the external service entrance breaker (located outside of the enclosure) to ON.
5. To reset the APX internal AC LINE circuit breaker, press the button (the white portion on the stem will not be visible).
6. Measure the output voltage at the APX output connector, using a true reading RMS digital multimeter. An acceptable voltage range is between 57 and 63 VAC for 60VAC output models (45.6 to 50.4 for 48V models).
7. If the AMM-C Ammeter option is installed (APX models only), ensure that the current draw is in the correct range, (for example, below 8A for 8A units, and below 14A for 14A units).
8. Place the cover on the APX, aligning the tabs on the cover with the base plate assembly. Secure the hold-down screw and lock the enclosure.



NOTE:

In Step 6, if a non-RMS type voltmeter is used, the reading may be off by as much as 10% due to the “quasi” square wave output of the ferroresonant transformer.

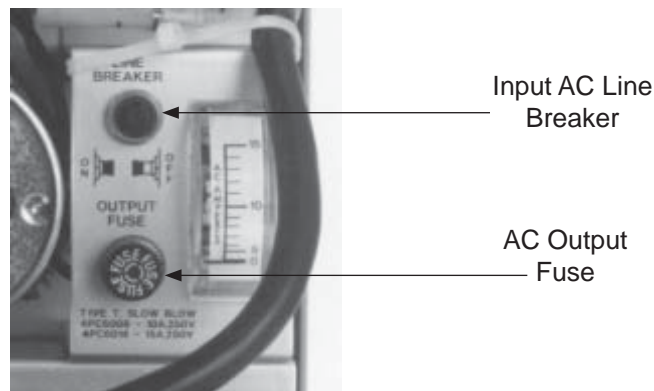

Fig. 3-1, APX Circuit Breaker and Fuse Location

3.0 Operation, continued

3.2 Shutdown and MTA Removal



WARNING!

Use heavy gloves when handling a power module that has just been taken out of service. The ferroresonant transformer generates heat and may cause burns if handled with bare hands.

Shutdown Procedure:

1. Switch the external service disconnect circuit breaker to OFF.
2. Unplug the power cord.
3. Disconnect the APX output connector.
4. Loosen the captive screw located on the bottom of the APX enclosure that secures the MTA to the baseplate assembly and remove the MTA from the baseplate.
5. If reinstalling a transformer assembly or upgrading, reverse the above procedure.

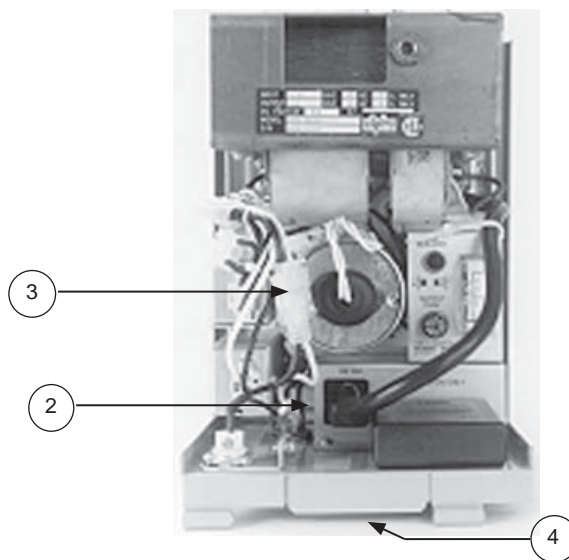
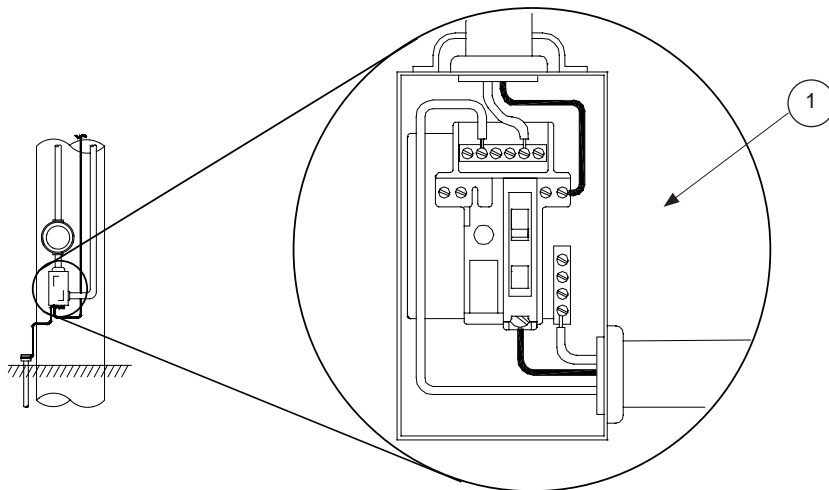

Fig. 3-2, Shutdown and MTA removal

4.0 Troubleshooting and Repair

Symptom	Probable cause	Remedy
No output to cable (no AC line power)	<ul style="list-style-type: none"> Utility power outage AC power cord unplugged AC input circuit breaker tripped. 	<ul style="list-style-type: none"> Use voltmeter to verify 120VAC (or 230VAC at receptacle) Plug in AC power cord Reset AC circuit breaker.
No output to cable (AC line power is available).	<ul style="list-style-type: none"> AC output fuse open Local seizure screw Poor connection at cable output connector Loose connection at transformer lug 	<ul style="list-style-type: none"> Replace fuse Tighten seizure screw Check connector Check connection
Incorrect output voltage.	<ul style="list-style-type: none"> Incorrect type of voltmeter used. Under-loaded output (<1A) Over-loaded output Faulty tank circuit capacitor (may appear swollen or distorted; may leak oil). 	<ul style="list-style-type: none"> Use a TRUE RMS meter Correct or increase load Reduce load Replace capacitor, C1

Table 4.1, Troubleshooting Guide

4.1 Return Procedure

When returning a unit for service please include the power supply maintenance log. The log helps the technician troubleshoot the problem.

Please use the original shipping container. If the original container is not available, use at least three inches of shock absorbing material to prevent damage during shipping.



NOTE:

Do not use popcorn-type material. Alpha Technologies is not responsible for damage caused by improper packing on returned units.

Alpha products may be returned by either method listed below:

- On the Internet follow these steps:
 - Go to www.alpha.com.
 - Select your region from the drop-down menu.
 - Select the link for "Support."
 - From the drop-down menu, choose "RMA Request Form (PDF)."
- Or call (800) 322-5742 for assistance.

4.0 Troubleshooting and Repair, continued

4.2 Replacement Parts

The following parts, available from Alpha Technologies, can be replaced in the field. When you order parts, please specify both the model number from the nameplate and the part number listed below

Type	Description	Part Number	Used in Models
Capacitor, oil-filled	60 μ F; 370VAC	210-017-10	(APX) 6014, 6014E, 6014P
Capacitor, oil-filled	100 μ F; 240VAC	210-018-10	(APX) 6008, 6014E, 6008E, 6008P
Circuit Breakers Thermal	12A; 250VAC, 28VDC	470-007-10	(APX) 6014
Circuit Breakers Thermal	5 Amp; 250VAC; 28VDC	470-001-10	(APX) 6008E, 4808E, 6008P
Circuit Breakers Thermal	8A; 250VAC; 28VDC	470-004-10	(APX) 6008, 6014E, 6014P
Fuses, Slow Blow	1/4" x 1-1/4"; 15A	460-043-10	(APX) 6014, 6014E, 6014P
Fuses, Slow Blow	1/4" x 1-1/4", 10A	460-102-10	(APX) 60008, 6008E, 4808E, 6008P

Table 4-2, Replacement Parts

5.0 Specifications

5.1 APX Schematics

The schematic diagram displays the main components of the APX Series, as well as where the options are electrically installed in the circuit. See Section 2.10 for details on installing available options..

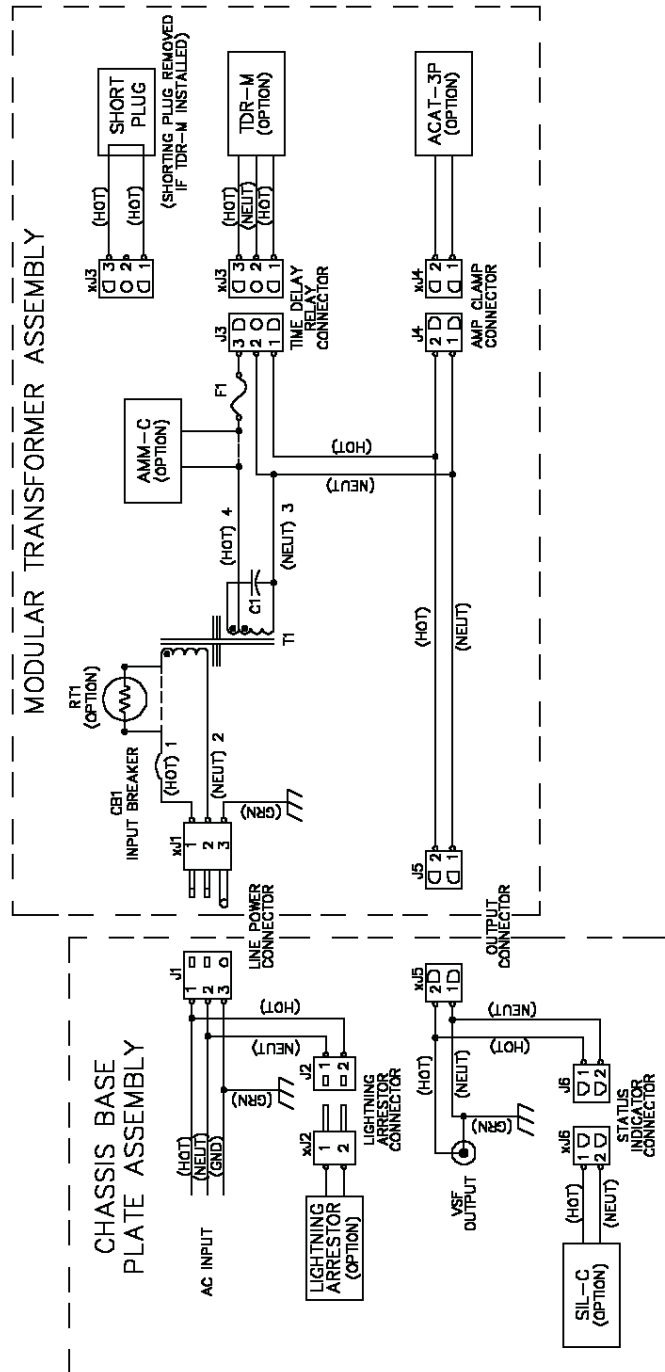

Fig. 4-1, APX Schematic

5.0 Specifications, continued

5.1 APX Schematics, continued

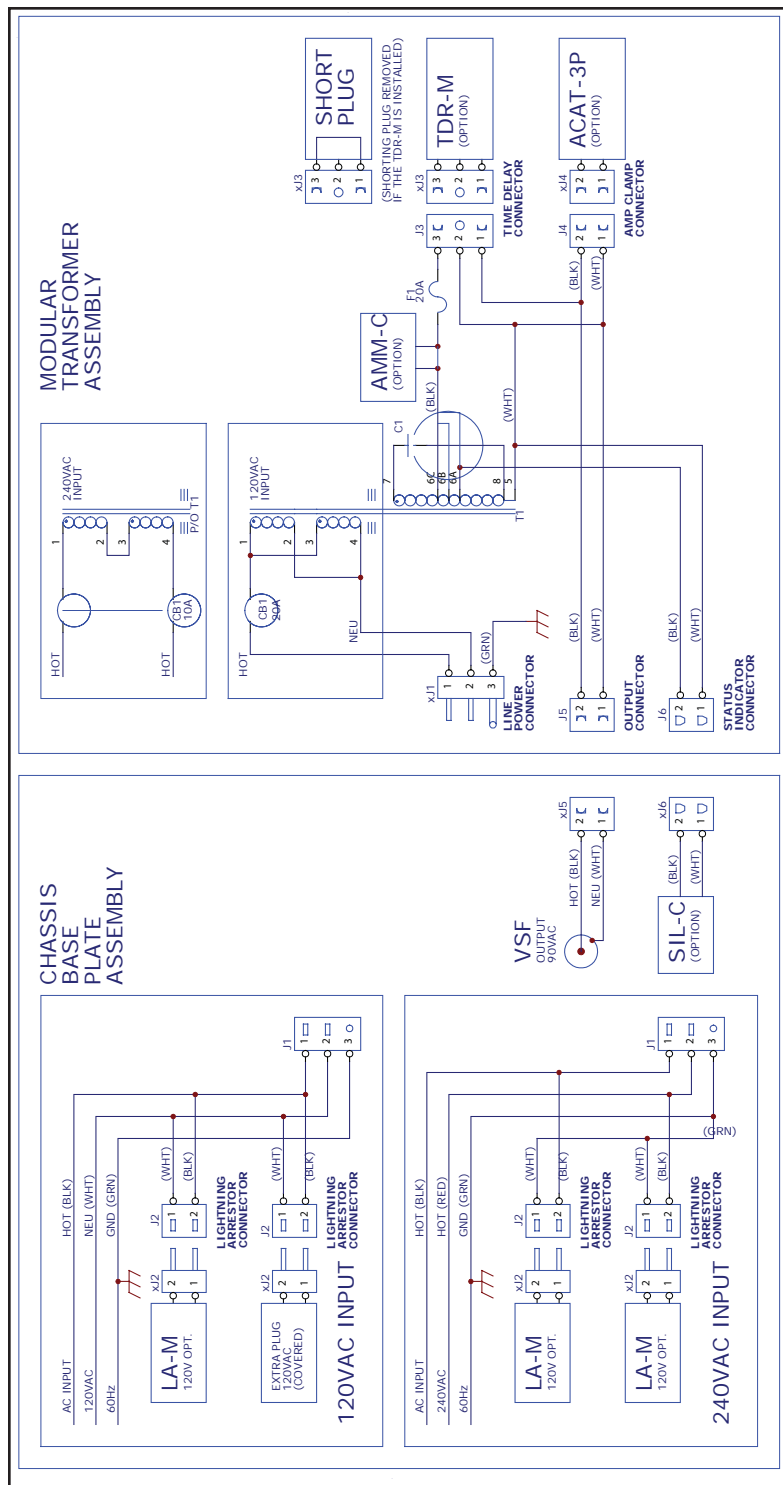

Fig. 4-2, APX 90V Schematic

5.0 Specifications, continued

5.2 APX Specifications

Model	APX 6008 E	APX 6014 E	APX 6008 P	APX 6014 P	APX 4808 E	APX 9015
Input Voltage (Nom)	120 230	120 230	220	220	230	240
Input Freq (Hz)	60 50	60 50	60	60	50	60
Input Current (A) (Max)	3.5 1.9	6.2 3.2	2.3	3.4	2	11.2
Output Voltage (VAC) (Nom)	60 60	60 60	60	60	40	90/75/60
Output Current (A) (Max)	8 8	14 14	8	14	8	15
Output Power (VA)	480 480	840 840	480	840	384	1350
Output Current Limit	150% of Max Output Rating					
Regulation	+/- 5%					
Input Protection (Circuit Breaker)	8 Amp	12 Amp	8 Amp	12 Amp	8 Amp	20 Amp
Output Protection (Fuse)	10 Amp	15 Amp	10 Amp	15 Amp	10 Amp	20 Amp
Efficiency	90% or better with nominal input voltage, frequency, full load 25c ambient					
Finish	Gray, ASA Polyester Powder Coat					
Operating Temp Range	-40° F to +130° F (-40° C to +55° C)					
Dimensions HxWxD						15" x 10.5" x 7.5" (381mm x 267mm x 190mm)
Pole mount	11.75" x 7.5" x 10.5" (298mm x 190mm x 267mm)					
Shelf mount	2.3" x 6.7" x 11.6" (60mm x 170mm x 295mm)					
w/MTA	7.9" x 6.7" x 11.6" (200mm x 170mm x 295mm)					
Pedestal mount (PM)	27.3" x 8.5" x 8.5" (693mm x 216mm x 216mm)					
Universal Bracket	14.0" x 7.1" x 7.35" (356mm x 180mm x 187mm)					
Rack mount	7.0" x 19" x 6.5" (178mm x 483mm x 165mm)					
Wall mount Bracket w/PM unit installed	7.1" x 2.7" x 2.0" (180mm x 69mm x 51mm)					
Weight (lbs/kg)	21/14.5	30/13.6	24/10.9	34/15.4	22/10	48/21.7

Table 5-1, APX Series Specifications

Power

Alpha Technologies 

Alpha Technologies
3767 Alpha Way
Bellingham, WA 98226
USA
Tel: +1 360 647 2360
Fax: +1 360 671 4936
Web: www.alpha.com

Alpha Technologies Ltd.
4084 McConnell Court
Burnaby, BC, V5A 3N7
CANADA
Tel: +1 604 430 1476
Fax: +1 604 430 8908

Alpha Technologies
Europe Ltd.
Twyford House
Thorley
Bishop's Stortford
Hertfordshire
CM22 7PA
UNITED KINGDOM
Tel: +44 0 1279 501110
Fax: +44 0 1279 659870

Alpha Technologies GmbH
Hansastraße 8
D-91126 Schwabach
GERMANY
Tel: +49 9122 79889 0
Fax: +49 9122 79889 21

Alphatec, Ltd
P.O. Box 56468
Limassol, Cyprus
CYPRUS
Tel: +357 25 375675
Fax: +357 25 359595

AlphaTEK ooo
Khokhlovskiy Pereulok 16
Stroenie 1
109028 Moscow
RUSSIA
Tel: +7 495 916 1854
Fax: +7 495 916 1349

Alphatec Baltics
S. Konarskio G. 49
Vilnius 2009
LITHUANIA
Tel: +350 5 210 5291
Fax: +350 5 210 5292

Alpha Technologies
5 Avenue Victor Hugo
F-92140 Calmart France
FRANCE
Tel: +33 3 41 90 07 07
Fax: +33 1 41 90 93 12