

Clarke®

PUMP



1HP SWIMMING POOL PUMP

Model SPP10

Part No: 7175030

OPERATING & MAINTENANCE INSTRUCTIONS



INTRODUCTION

Thank you for purchasing this CLARKE swimming pool pump.

Before attempting to operate the pump, it is essential that you read this manual thoroughly and carefully follow all instructions given. In doing so you will ensure the safety of yourself and that of others around you, and you can also look forward to the pump giving you long and satisfactory service.

DESCRIPTION

This self-priming, centrifugal swimming pool pump is designed for the filtration of small to medium size swimming pools and for pumping clean water only. Operating with contaminated or salt water should be avoided.

When used with permanently installed pools, the pump should be fixed in a horizontal position and the use of a non-return valve will facilitate immediate priming. The pump inlet is higher than the impeller inlet so that it can start operating when only the pump body is filled with water.

Upon receipt, any damage or deficiency should be reported to your CLARKE dealer immediately.

CONTENTS

1 x Swimming Pool Pump (c/w integral Pre-filter Basket)

2 x Inlet /Outlet Connectors

2 x Inlet /Outlet Connector Fixing Nuts

2 x Inlet /Outlet Connector O-Ring Seals

1 x Non-return Valve

1 x Filter Cover Removal Wrench

GUARANTEE

This CLARKE product is guaranteed against faulty manufacture for a period of 12 months from the date of purchase. Please keep your receipt as proof of purchase.

This guarantee is invalid if the product is found to have been abused or tampered with in any way, or not used for its intended purpose.

Faulty goods should be returned to their place of purchase, no product can be returned to us without prior permission.

This guarantee does not effect your statutory rights.

GENERAL SAFETY PRECAUTIONS



WARNING: The SPP10 pump is not a submersible pump. On no account should it ever be immersed in water.



Always connect the pump to an earthed power supply via a RCD.

1. **ALWAYS** keep the pump room clean and well lit. Floors should always be kept clear. Cluttered or dark areas invite accidents.
2. **NEVER** over-reach. Keep your proper footing and balance at all times when installing or maintaining the pump.
3. **NEVER** direct any water discharge towards electrical wiring or equipment.
4. **ALWAYS** thoroughly familiarise yourself with this pump & its operation, and follow all instructions in this manual. Never allow persons unfamiliar with these instructions to operate the pump.
5. **ALWAYS** ensure that the pump is properly installed to prevent it from moving during operation, and that the immediate area surrounding the pump is kept clear.
6. **ALWAYS** maintain the pump with care and keep it clean for best / safest performance.
7. **NEVER** use this product if any part is damaged. Have it inspected and repaired by your local Clarke dealer. Always turn the pump off before carrying out any maintenance.
8. **NEVER** modify this pump in any way. Use it ONLY for the purpose for which it is designed.
9. **NEVER** use for pumping flammable liquids or corrosive chemicals. This pump is designed to pump clean water only.
10. **NEVER switch the pump ON when the pool is in use. ALWAYS disconnect the pump from the electrical supply when the pool is in use.**
11. This pump must be connected to an earthed power supply via a RCD.
12. **ALWAYS** have the pump serviced by your local CLARKE dealer, using only identical replacement parts. This will ensure the safety of the pump is maintained. The use of non standard parts could be hazardous.

Your CLARKE water pump has been designed to give long and trouble free service. If, however, having followed the instructions in this booklet carefully, you encounter problems, take the unit to your local CLARKE dealer.

Please keep these instructions in a safe place for future reference.

ELECTRICAL CONNECTIONS



WARNING! Read these electrical safety instructions thoroughly before connecting the product to the mains supply.

Before switching the product on, make sure that the voltage of your electricity supply is the same as that indicated on the rating plate. This product is designed to operate on 230VAC 50Hz. Connecting it to any other power source may cause damage.

This product may be fitted with a non-rewireable plug. If it is necessary to change the fuse in the plug, the fuse cover must be refitted. If the fuse cover becomes lost or damaged, the plug must not be used until a suitable replacement is obtained.

If the plug has to be changed because it is not suitable for your socket, or due to damage, it should be cut off and a replacement fitted, following the wiring instructions shown below. The old plug must be disposed of safely, as insertion into a mains socket could cause an electrical hazard.



WARNING! The wires in the power cable of this product are coloured in accordance with the following code:

Blue = Neutral

Brown = Live

Yellow & Green = Earth

If the colours of the wires in the power cable of this product do not correspond with the terminal markings of your plug, proceed as follows:

- The wire which is coloured Blue must be connected to the terminal which is marked N or coloured Black.
- The wire which is coloured Brown must be connected to the terminal which is marked L or coloured Red.
- The wire which is coloured Yellow & Green must be connected to the terminal which is marked E or  or coloured Green.

Plug must be BS1363/A approved

Earth
(Green and Yellow)

Neutral
(Blue)

Always fit a 13 Amp fuse.

Live
(Brown)

Ensure that the outer sheath of the cable is firmly held by the clamp

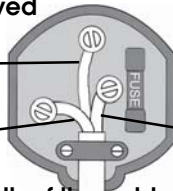

Always connect this product to the mains supply via a Residual Current Device (RCD)

If in any doubt, consult a qualified electrician. DO NOT attempt any repairs yourself.

INSTALLATION

Because of the variety of possible installations, no plumbing accessories are supplied with your pump, however accessories are available from your nearest CLARKE dealer. Contact your CLARKE dealer for further information, or CLARKE International Sales Department on 01992 565333.

Note: It is recommended that the end user should consult a qualified installer if there are any doubts as to the suitability of this product for a particular installation.

IMPORTANT: The pump MUST NOT be connected to the mains power supply until all hose/pipe installation is completed.

INSTALLATION OF THE PUMP

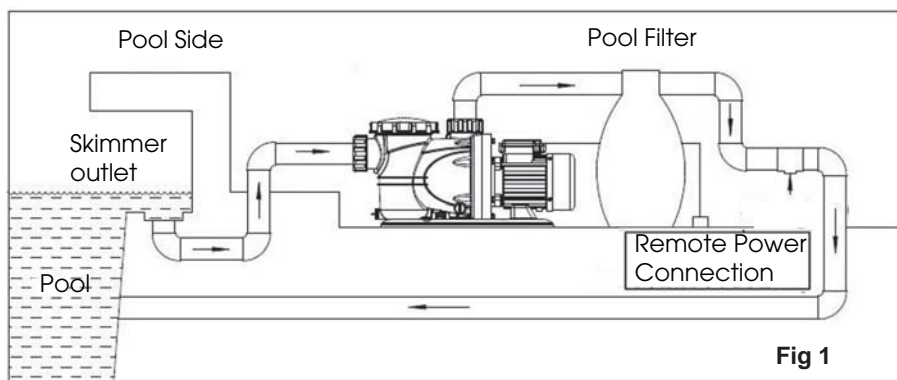

A typical installation of the pump is shown in Fig 1. The pump must always be installed and operated in a horizontal position i.e. with the outlet port facing vertically upwards. The fixing holes in the base should be used to secure the pump firmly in its operating position. Mount the pump on raised blocks or a purpose built platform to protect it from flooding.

Always ensure there is adequate air circulation around the motor and that the transparent filter cover is accessible so that the filter basket can be removed for cleaning. The pump should be installed in a dry, well ventilated enclosure, sheltered from rain, such as a purpose built pump room.

The pump is usually installed between the pool skimmer and the pool filter and should be positioned as near to the pool water level as possible.

ELECTRICAL CONNECTION

The pump should be located at a safe distance, (usually 2 metres), away from the pool, and the power supply should be at least 3.5 metres from the pool. If in doubt, please contact your electrical specialist and refer to the International Electrical Commission (IEC) standard, (Electrical Installations for Buildings-part 7), referring to 'swimming pools and other basins'.

Avoid situations where the pump could become drenched with water as neither the motor or terminal box are designed to be waterproof. Ensure the pump & its cable do not create a safety hazard for people walking past it.

PIPE/HOSE CONNECTIONS

The pump inlet will be connected to the pool skimmer and/or pool drain connection, depending upon the installation layout, and the discharge outlet should be connected to your water filter.

The inlet and outlet adaptors supplied with the pump are designed to fit to rigid pipe-work. The inner bore diameter of the adaptors is 50 mm. Therefore pipes with the same nominal diameter should be used. These should be fixed in place using a proprietary adhesive/sealant suitable for pressurised pipe-work applications.

These can be extended with the use of suitable 50 mm I/D hose secured with a worm drive clip. Ensure all connections are air tight. Tighten them enough to secure the hose during pressurised operation, but not so tight as to crack the plastic inlet/outlet connectors.

Where the pump is to be a permanent fixture, vibration and strain on adjacent parts can be reduced by the insertion of a short flexible section of hose between any rigid pipework and the immediate area of the pump.

Any air leaks in the suction line will inhibit priming and reduce the capacity of the pump. Ensure there are no kinks in any flexible hose used.

The performance of your pump will be affected by the diameter of the inlet pipe - any restriction will greatly reduce the flow. We recommend that you always use a pipe diameter at least equal to, or greater than the diameter of the pump connections i.e. 50 mm diameter.

To prevent unnecessary strain or possible distortion to the pump, ensure that adequate support is provided to the hoses and or pipes. They will be considerably heavier when filled with water.

It is suggested that suction and delivery isolation valves are fitted in order to isolate the pump. A gate valve may be installed in-line on the delivery side (outlet port) of the pump which can be adjusted as required to regulate the flow of water and can assist in priming the pump.

Protect the pump and pipework from freezing with the addition of suitable lagging. The formation of ice may cause serious damage.

OPERATION

1. Open any valves in the pipeline.
2. If operating the pump for the first time, unscrew the filter cover on top of the pump using the wrench supplied and prime the pump by filling completely with water.

Note: The pump is only self-priming when filled with water. Refilling is only necessary if the pump has been drained, or if all the water has been lost.



3. Connect to the power supply and switch on. Water should start to flow through the system. Check for any leaks and repair as necessary.
4. If the motor fails to start, or the pump does not deliver water, refer to TROUBLESHOOTING on page 9. Never operate the pump when not filled with water or if the inlet is blocked.
 - The level of water in the pump can be seen through the transparent filter cover.

Note: Filling the suction pipe with water will speed up the priming process, and it is suggested that a non-return valve be fitted to the end of the suction pipe.

5. Stop the pump by switching off the power supply.

CARE DURING USE

1. Do not allow the pump to run dry, otherwise the seal between the pump and motor may be damaged. If a leak is noticed at this point, it may indicate that the seal is worn and therefore in need of replacement. Contact your CLARKE dealer, or the Clarke International Service Department for advice.
2. In the event of a blockage, where debris has entered the suction chamber, the sieve and chamber can be cleaned out as described under MAINTENANCE.
3. Should contaminants come into contact with the pump, flush through with cold water as soon as possible to prevent damage to the pump. DO NOT USE for pumping chemicals or other corrosive liquids (other than pool purification chemicals in their correct mix ratio).
4. If the pump is being used to drain the pool, ensure there is adequate drainage and there is no risk of damage to property as a result of water being discharged. If a flexible hose must be laid across a roadway, protect it with wooden planking.

MAINTENANCE

The only maintenance required is a regular inspection to ensure that debris is not blocking the passage of water through the pump.

Clean the filter basket periodically after closing any inlet and delivery valves and removing the filter cover, using the wrench provided. Lift out the filter basket and clean it in water, check the cover O-ring is in good condition before reassembly.

If you suspect the pump is blocked by silt, leaf debris etc, disconnect it from the mains supply and backflush to clear any blockage through the drain plug. You will need to disconnect the outlet hose and lift out the non-return valve to do this.

Always keep the pump in a clean condition, checking regularly for loose bolts or a damaged power cable etc.



AFTER USE

After use, and if the pump will not be used over the winter period, or whenever there is danger of freezing, always drain the pump body. If the pump has been used with contaminated or salty water, it should be thoroughly flushed with clean water following use, both inside and out. It should then be drained before replacing the drain plug, and covered over, if not already installed in a clean, dry environment sheltered from the weather. Remember to re-prime the pump when returning to service.

In the event that dismantling and overhaul of the pump is necessary, contact your CLARKE International Service Department on 020-8988-7400.

ACCESSORIES

A wide range of accessories is available, including Filters, Hoses and clips, Couplings and 90° Hose Adaptors, etc. Contact your Clarke dealer for further information. The use of parts other than genuine Clarke replacement parts may result in possible safety hazards or decreased machine performance, and will invalidate your warranty.

ENVIRONMENTAL PROTECTION



Do not dispose of this product with general household waste. It must be disposed of according to the laws governing Waste Electrical and Electronic Equipment at a recognised disposal facility. Any redundant accessories and packaging should be sorted and taken to a recycling centre to be disposed of appropriately.

Clarke

TROUBLESHOOTING

PROBLEM	CAUSE	SOLUTION
Pump does not run.	No mains supply	Check fused power supply and replace fuse if necessary (check fuse rating). Check circuit breaker.
	Impeller seized/blocked.	Disconnect pump from mains supply. Investigate cause and clear blockage.
Pump fails to prime.	Air leaks through suction hose joints (damaged hose, broken clamp, damaged/ill-fitting gasket)	Repair connections/replace hose as necessary.
	Blocked inlet hose.	Check pipeline and pool skimmer for blockage. Check any inlet valve fitted is fully open.
Pump runs but gives poor output.	Pump inlet filter basket is blocked.	Check and clean filter basket.
	Congested material inside pump.	Clean out filter basket & backflush pump.
	Suction or delivery line obstructed.	Remove obstruction and ensure there are no kinks in delivery line.
	Inlet pipe leakage.	Check inlet pipe and connector for leaks. Tighten as required.
	Air leaks through damaged seal.	Renew seal.
	Impeller damaged and making poor seal.	Return to your CLARKE dealer for repair.
	Impeller / mechanical seal is badly worn.	Return to your CLARKE dealer for repair.
	High friction losses in the suction line.	Avoid unnecessary curves, restrictions or valves.
	Pump badly sited resulting in suction lift too high.	Set pump as close as possible to the level of the water to be pumped.
Sudden loss of flow.	Blockage of inlet pipe.	Check pipeline and pool skimmer for blockage.

TROUBLESHOOTING

PROBLEM	CAUSE	SOLUTION
Undue vibration or noise.	Excessive flow of water.	Decrease flow of water, by adjusting inlet/outlet valves in system.
	Resistance in inlet pipe caused by obstruction.	Check pipe and clean out as necessary.
	Loose rotating component	Return to your dealer for repairs.
	Installation of pump is unstable.	Stop pump and re-position.
	Air pocket in pump or pipeline.	Release drain plug in impeller housing to release air.
	Damaged impeller	Return to your CLARKE dealer for repair.

SPP10 PERFORMANCE

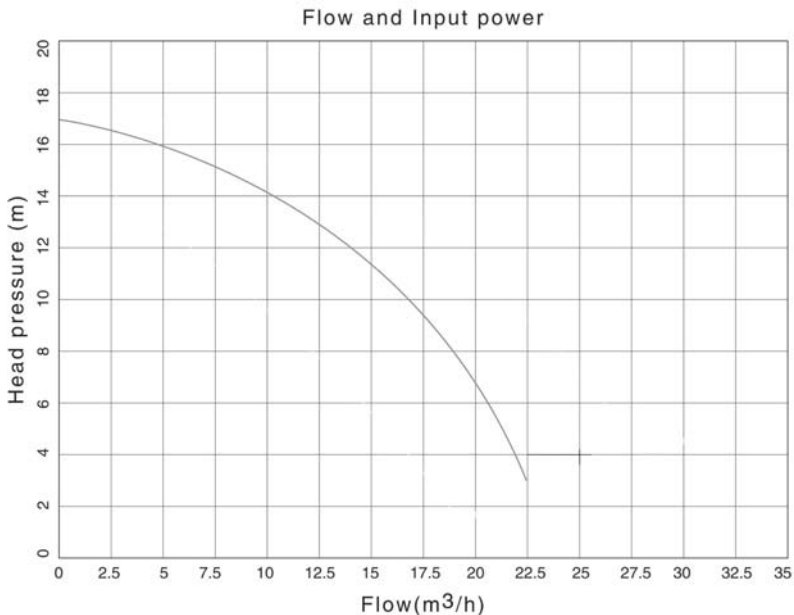

TECHNICAL SPECIFICATION

SPP10	
Weight	9.95 kg
Dimensions (L x W x H)	610 x 190 x 316 mm
Max Flow	366 L/min
Max Head	15 m
Operating Temperature	35°C
Water Classification	Swimming Pools/Clean Water
Return Valve Type	Flap type at outlet
Inlet & Outlet Size	50 i/d / 56 o/d (mm)
Power Supply	220-240V @ 50Hz
Output Power	1HP (750 W)
Sound Pressure Level	68.8 dB LpA
Sound Power Level	75.3 dB LwA
Guaranteed Sound Power	78 dB LwA
Pump type	Centrifugal

Please note that the details and specifications contained herein, are correct at the time of going to print. However, CLARKE International reserve the right to change specifications at any time without prior notice.

PARTS LIST

No	Description	Part No	qty
1	Drain Plug	ZGSPP1001	2
2	Sealing O-Ring	ZGSPP1002	2
3	Pump Casing	ZGSPP1003	1
4	Bolt	ZGSPP1004	2
5	Washer	ZGSPP1005	2
6	Sealing Ring	ZGSPP1006	1
7	Diffuser	ZGSPP1007	1
8	Impeller	ZGSPP1008	1
9	Mechanical Seal	ZGSPP1009	1
10	Gasket	ZGSPP1010	1
11	Base Plate	ZGSPP1011	1
12	Mounting Rubber	ZGSPP1012	1
13	Mounting Flange	ZGSPP1013	1
14	Washer	ZGSPP1014	8
15	Wave Washer	ZGSPP1015	12
16	Hex Bolt	ZGSPP1016	8
17	Waterproof Gland	ZGSPP1017	1
18	Pump Support	ZGSPP1018	1
19	Socket Head Bolt	ZGSPP1019	4
20	Washer	ZGSPP1020	4
21	X-Hd Machine Screw	ZGSPP1021	4
22	Washer	ZGSPP1022	4
23	Tie Bolt	ZGSPP1023	4
24	Fan Cover	ZGSPP1024	1
25	Fan	ZGSPP1025	1
26	End Plate	ZGSPP1026	1
27	Spring Washer	ZGSPP1027	1
28	Circlip	ZGSPP1028	1
29	Power Cable	ZGSPP1029	1
30	Washer	ZGSPP1030	1
31	Gasket	ZGSPP1031	1

No	Description	Part No	qty
32	Sealed Sheath	ZGSPP1032	1
33	Cable Clip	ZGSPP1033	1
34	X-Hd Machine Screw	ZGSPP1034	2
35	Wave Washer	ZGSPP1035	1
36	Gasket	ZGSPP1036	1
37	Tamper-proof Screw	ZGSPP1037	4
38	Cover Panel	ZGSPP1038	1
39	Gasket	ZGSPP1039	1
40	Capacitor	ZGSPP1040	1
41	Terminal Board	ZGSPP1041	1
42	Nut	ZGSPP1042	6
43	Washer	ZGSPP1043	6
44	Connecting Block	ZGSPP1044	6
45	X-Hd Machine Screw	ZGSPP1045	6
46	Capacitor Box	ZGSPP1046	1
47	Gasket	ZGSPP1047	1
48	Motor Stator	ZGSPP1048	1
49	Bearing	ZGSPP1049	2
50	Circlip	ZGSPP1050	1
51	Motor Rotor	ZGSPP1051	1
52	X-Hd Machine Screw	ZGSPP1052	1
53	Flap Valve	ZGSPP1053	1
54	Valve Body	ZGSPP1054	1
55	Wrench	ZGSPP1055	1
56	Retaining Ring	ZGSPP1056	1
57	Sealing Ring	ZGSPP1057	1
58	Sieve Filter	ZGSPP1058	1
59	O-Ring	ZGSPP1059	1
60	O-Ring	ZGSPP1060	2
61	Connector	ZGSPP1061	2
62	Securing Ring	ZGSPP1062	2

PARTS DIAGRAM



DECLARATION OF CONFORMITY



Clarke[®]
INTERNATIONAL

Hemnall Street, Epping, Essex CM16 4LG

DECLARATION OF CONFORMITY

This is an important document and should be retained.

Product Description: 1hp Swimming Pool Pump
Model number(s): SPP10
Serial / batch Number: N/A
Date of Issue: 14/09/2011
(Noise Conformity)
Notified Body: TUV SUD Industrie Service GmbH
Westendstrabe 199
80686 Munchen
Germany

Technical Documentation Holder: A.R. Pond
Clarke International
2a Shrubland Road
London E10,7RB
UK

Conformity Assessment Procedure: to 2000/14/EC Annex VI
Manufacturer: Clarke International
Noise Related Value: 1.1kW
Measured Sound Power Level: 75.8dB
Guaranteed Sound Power Level: 78 dB

DECLARATION OF CONFORMITY



Clarke[®]
INTERNATIONAL

Hemnal Street, Epping, Essex CM16 4LG

DECLARATION OF CONFORMITY

This is an important document and should be retained.

We hereby declare that this product(s) complies with the following directive(s):

2004/108/EC *Electromagnetic Compatibility Directive.*

2006/95/EC *Low Voltage Equipment Directive.*

2002/95/EC *Restriction of Hazardous substances.*

2000/14/EC *Noise Emissions Directive, (amended by 2005/88/EC).*

The following standards have been applied to the product(s):

EN 60335-1/A2:2002+A1+A11+A12+A2+A13, EN 60335-2-41:2003+A1, EN 62233:2008

EN 55014-1:2006, EN 55014-2:1997+A1:2001, EN 61000-3-2:2006, EN 61000-3-3/A1:2001+A2:2005.

The technical documentation required to demonstrate that the product(s) meet(s) the requirement(s) of the aforementioned directive(s) has been compiled and is available for inspection by the relevant enforcement authorities.

The CE mark was first applied in: 2010

Signed:



J.A. Clarke
Director

A SELECTION FROM THE VAST RANGE OF

Clarke®

QUALITY PRODUCTS

AIR COMPRESSORS

From DIY to industrial, Plus air tools, spray guns and accessories.

GENERATORS

Prime duty or emergency standby for business, home and leisure.

POWER WASHERS

Hot and cold, electric and engine driven - we have what you need

WELDERS

Mig, Arc, Tig and Spot. From DIY to auto/industrial.

METALWORKING

Drills, grinders and saws for DIY and professional use.

WOODWORKING

Saws, sanders, lathes, mortisers and dust extraction.

HYDRAULICS

Cranes, body repair kits, transmission jacks for all types of workshop use.

WATER PUMPS

Submersible, electric and engine driven for DIY, agriculture and industry.

POWER TOOLS

Angle grinders, cordless drill sets, saws and sanders.

STARTERS/CHARGERS

All sizes for car and commercial use.



PARTS & SERVICE: 020 8988 7400

E-mail: Parts@clarkeinternational.com or Service@clarkeinternational.com

SALES: UK 01992 565333 or Export 00 44 (0)1992 565335

Clarke INTERNATIONAL Hemnall Street, Epping, Essex CM16 4LG
www.clarkeinternational.com