



**DS160 Strobe**

Instruction Manual

Please read all instructions before using this product.

# TABLE OF CONTENTS

<b>IKELITE DS160 STROBE</b> .....	3	Confidence Signal .....	18
Specifications .....	3	Firing Mode Switch .....	18
Introduction .....	4	<b>STROBE READY LIGHT</b> .....	19
Starting Out .....	4	Strobe Ready Light and TTL Housing ..	19
Strobe Compatibility .....	4	<b>Camera Ready Light</b> .....	19
Strobe Power .....	4	Triggered via Sync Cord .....	19
DS160 Strobe .....	5	<b>RECOMMENDATIONS</b> .....	20
Overview of DS160 Features .....	5	Visual Inspections .....	20
<b>OPENING AND CLOSING</b> .....	6	Insurance .....	20
Opening the Strobe .....	6	Tips .....	20
O-ring .....	6	Lubricant .....	20
Closing the Strobe .....	6	<b>MAINTENANCE</b> .....	21
Opening and Closing (Illustration).....	7	Cleaning and Storage .....	21
<b>LI-ION BATTERY PACK 4067</b> .....	8	<b>TROUBLESHOOTING</b> .....	22
Charging the Battery Pack .....	9	Strobe Will Not Fire .....	22
Storage .....	9	<b>AIRLINE TRAVEL</b> .....	23
Warnings .....	9	<b>TECHNICAL SUPPORT</b> .....	23
Using NiMH or Ni-Cad Battery Packs ..	9	<b>LIMITED WARRANTY</b> .....	23
<b>SMART CHARGER 4067.1</b> .....	10	<b>PRODUCT REGISTRATION</b> .....	24
Specifications .....	10		
Includes .....	10		
Usage .....	10		
Warnings .....	10		
<b>FLASH DIFFUSER 0591.3</b> .....	11		
Using the Diffuser .....	11		
Diffuser Installation and Removal .....	11		
<b>ARM SYSTEMS/STROBE MOUNTS</b> ..	12		
Ikelite Arm Systems .....	12		
Ikelite Mounts .....	12		
<b>STROBE CONNECTION</b> .....	13		
Strobe Connection (Illustration) .....	14		
<b>USING AS HARD-WIRED STROBE</b> ..	15		
<b>USING AS HARD-WIRED STROBE</b> <b>WITHOUT TTL</b> .....	15		
<b>AIMING THE STROBE</b> .....	16		
<b>SWITCHES / FUEL GAUGE</b> .....	17		
On/Off Switch .....	17		
Fuel Gauge .....	18		

# IKELITE DS160 STROBE

## DS160 SPECIFICATIONS

**CE - Compliant with applicable EU directives**

**Complies with FCC part 15, subpart B, Section 15.109 for Class "B" Products**

### Specifications

Battery Pack .....	Li-ion module, 7.4v, 3900mAh
Weight .....	2.5 lb (1130g)
Size .....	9.6 cm dia. x 17.9 cm (3.75 in dia. x 7 in)
Depth Rating .....	90m - 300 feet

### Strobe

Energy Rating .....	160 watt-sec
Recycle Time .....	1.4 sec
Angle of Coverage .....	90 degrees..... 100 degrees with diffuser
Guide # (ISO 100) feet .....	76 surface - 38 underwater
Guide # meters .....	24 surface - 12 underwater
Color Temperature .....	4800 degrees Kelvin
Full Power Flashes .....	450 flashes per full charge
Firing Modes .....	TTL, Full, 9 fractional powers

### Modeling Light

Modeling Light .....	5-watt LED
----------------------	------------

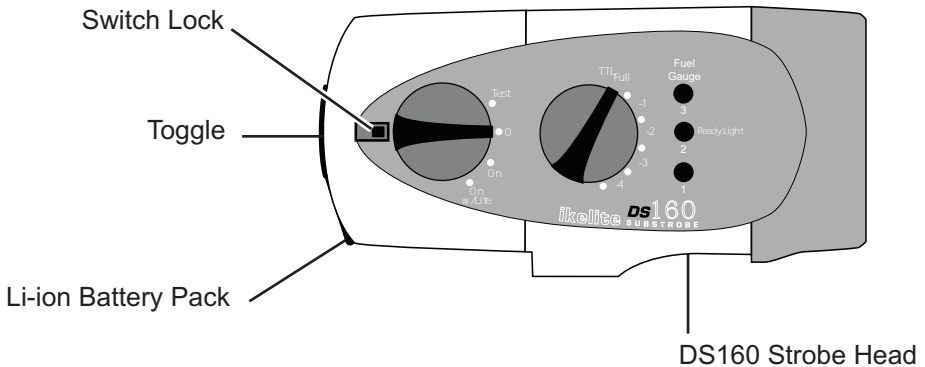

# **IKELITE DS160 STROBE (continued)**

## **INTRODUCTION**

Thank you for purchasing an Ikelite Strobe. Ikelite brings over 50 years of underwater photographic and lighting experience to the strobe market. Ikelite Strobes are designed and built in the USA by Ikelite to suit both the professional and the amateur photographer.

The purpose of a strobe is to illuminate the subject and assist the camera in taking vivid pictures. The Ikelite DS160 Strobe is equally suited for general and wide-angle photography, covering up to a full 100° angle with a diffuser.

The contents of this instruction manual are subject to change at any time without prior notice.

## **STARTING OUT**

Before using the Ikelite DS160 Strobe, please read this owner's manual thoroughly and retain it for future reference. Fully charge your strobe's battery pack prior to your first use.

Ikelite recommends becoming familiar with the features and functions of the Ikelite DS160 Strobe above water before trying the camera and strobe in the water. And, if you have not yet done so, it is suggested that you read your camera owner's manual as well.

## **STROBE COMPATIBILITY**

The DS160 Strobe is compatible with all Ikelite TTL systems and current digital cameras, as well as all older TTL film cameras including the Nikonos system. A variety of sync cords, sensors, and TTL adapters are available to connect to almost any camera system currently on the market.

## **STROBE POWER**

The DS160 recycles in a quick 1.4 sec from full discharge. When fired at a fractional power — whether in TTL or manual mode — the strobe recycles virtually instantaneously. Number of flashes per full charge will increase dramatically in most cases when using in TTL mode with a compatible camera system. The powerful DS160 is adjustable in 10 half-stop increments for precise control over your exposure when used in manual mode.

# **IKELITE DS160 STROBE (continued)**

## **DS160 STROBE**

The Ikelite DS160 Strobe combines high intensity output and wide coverage angle in a compact, versatile design. This strobe features 160 watt-sec. intensity and covers a full 100° using the diffuser. Special soft-lite reflector provides rich reds, oranges, and warmer flesh tones.

The DS160 is pre-flash compatible and operates with both traditional film cameras and digital still cameras. Multiple firing modes are featured, including TTL/Auto exposure.

The DS160 electronics are safely sealed separately from the battery pack. The industrial grade Li-ion batteries recycle in an incredible 1.4 seconds and the Li-ion battery pack is easily interchangeable with a spare unit. When in the "Batt w/Lite" position, the fuel gauge references the remaining battery capacity. Aim the DS160 and illuminate your subject's colors with the built-in modeling light / night diving light.

## **OVERVIEW OF DS160 FEATURES**

- Separate power and firing mode switches.
- Interchangeable battery pack features industrial grade Li-ion batteries.
- LED fuel gauge approximates the remaining battery capacity.
- Visual ready light indicates when strobe has recycled.
- Female Ikelite bulkhead connector accepts different camera sync cords and the EV-Controller 4100.6.
- Exposure guide label references recommended exposure settings.
- Separate diffuser provides softer lighting and wider coverage angle.

# OPENING AND CLOSING

## OPENING THE STROBE

Turn the strobe OFF, and place the strobe face down on a flat surface.

Slide the locking lever out by either grasping the sides of the lever and pulling it out OR use your thumb to apply slight pressure to the top of the lever and slide it out.

Flip the lever up and then rotate the lever counter-clockwise 90°. The internal spring automatically pushes open the strobe. Lift the rear section off of the strobe front (See illustrations on page 7). The rear section is the battery pack for the strobe.

The battery pack does NOT remain waterproof when removed from the strobe. Therefore, we suggest keeping the open portion of the battery pack pointed down while removing to eliminate the possibility of water droplets falling inside. The Li-ion batteries remain permanently secured inside the Li-ion battery pack.

The front section of the DS160, which houses the main electronics, is safely sealed separately from the battery pack. The front section will remain waterproof when the battery pack is removed. However, avoid salt-water contact with the battery pins. Damage/corrosion can cause a short circuit.

## O-RING

The o-ring is located on the inside rim of the battery pack. Keep the o-ring and the sealing surfaces clean. **DO NOT** stretch the o-ring when cleaning. It is not necessary to lubricate the o-ring. Never use spray lubricant because it may crack the plastic.

## CLOSING THE STROBE

Make sure the power switch has been rotated to the OFF position.

Place the front of the strobe face down on a flat surface. Check that the o-ring and sealing surfaces are clean; make sure the o-ring is positioned properly inside the rim of the battery pack. Place the locking lever in the open position (slide the lever out, flip the lever up, and rotate the lever counterclockwise 90 degrees until it stops).

Align the front and rear sections of the strobe. Lower the battery pack onto the front section of the strobe. Proper alignment of the two sections is extremely important to avoid possible damage to the internal components.

To seal the strobe, simply press down slightly on the rear of the battery pack and rotate the lever clockwise 90 degrees until it stops. Flip the lever down and then slide the lever into the locked position to properly seal the strobe.

# OPENING AND CLOSING (illustration)

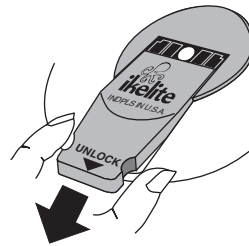

**Pull Out**

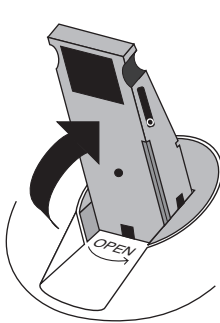

**Flip Up**

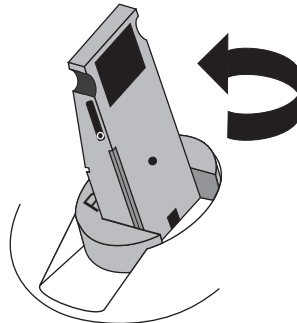

**Rotate**

# LI-ION BATTERY PACK 4067

The 4060.1 DS160 Strobe includes a Lithium Ion (Li-ion) battery pack and smart charger. The battery pack requires Smart Charger 4067.1 (page 10).

Li-ion Battery Pack 4067 is compatible with Ikelite's DS125, DS160 and DS161 Strobe. The battery pack must be attached to the strobe head for use in or underwater. Additional battery packs are available through an Ikelite dealer.

The battery pack does NOT remain waterproof when removed from the strobe. Therefore, we suggest keeping the open portion of the battery pack pointed down while removing to eliminate the possibility of water droplets falling inside.

The battery pack is factory sealed and contains no user-serviceable parts other than the O-ring. Do not disassemble the battery pack.

## Li-ion Battery Pack 4067

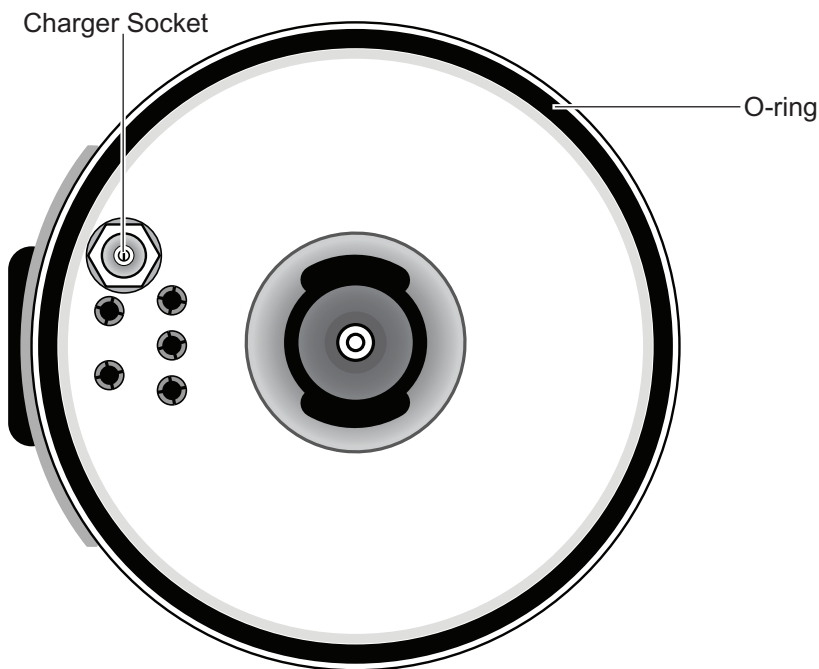



# LI-ION BATTERY PACK 4067 (continued)

## CHARGING THE BATTERY PACK

Requires Ikelite 4067.1 Smart Charger Li-ion. **Do not** attempt to charge the battery pack with other chargers. Use of an incompatible charger is a safety risk and may cause irreparable damage to the battery pack.

Typical recharge time is approximately 5 hours.

## STORAGE

Do not store a depleted battery pack for extended periods of time. Charge the battery pack to at least half full prior to storing. Always place the power switch in the locked OFF position. Store in a cool, dry place. We suggest storage of your strobe with the locking lever OPEN to allow any hydrogen/air mixture to escape.

## WARNINGS

- Always turn off and lock the battery power switch or disconnect the battery and store in a cool, dry place when not in use.
- The battery pack is not waterproof when removed from the strobe.
- Do not disassemble the battery pack.
- Do not expose the pack to heat.
- Do not use lubricant, cleaners, or any chemical on the o-ring or battery pack.
- NEVER use or charge a water damaged battery pack. Flooding may cause a short circuit and lead to overheating.
- Do not discard, crush or incinerate. Check local rules and regulations on electronic waste disposal and use an approved recycling facility.
- Do not ship or travel with a flooded or known defective battery pack.

## USING NIMH OR NI-CAD BATTERY PACKS

The DS160 Strobe head also accepts both 4066.5 NiMH battery packs and 4066 Ni-Cad battery packs in good working condition. Do not use a battery pack with dead or water damaged cells. If you intend to use an older battery pack on your new Strobe, please reference the notice dated 6/22/09 on the following web page:

[http://www.ikelite.com/web\\_pages/important.html](http://www.ikelite.com/web_pages/important.html).

# SMART CHARGER 4067.1

## SPECIFICATIONS

Compatibility .....	Ikelite 4067 Lithium-Ion Battery Pack
Input .....	100-240 Volts AC, 50-60 Hertz, 0.6 Amps
Output .....	8.4 Volts
Operating Temperature .....	32°F - 104°F (0°C - 40°C)
Storage Temperature.....	-4°F - 185°F (-20°C - 85°C)

## INCLUDES

- Smart Charger Li-ion with US plug flip out blades
- European plug adapter
- Australian plug adapter
- United Kingdom plug adapter

## USAGE

Use only with compatible Ikelite lithium-ion battery packs. Charge a battery pack to at least half full prior to storing for extended periods of time. This charger features flip out blades for use with US plugs.

Additional plug adapters are provided. Close the flip out blades and slide a compatible plug adapter on until it snaps into position.

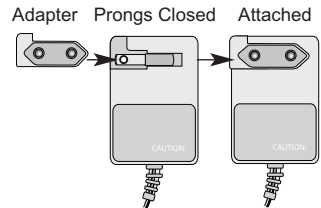

- Charging indicator LED:**   **OFF** .....Disconnected from pack  
  **FLASHING** .....Charging Mode  
  **SOLID** .....Full Charge

DO NOT attempt to charge or connect a battery pack that has flooded or leaked. Electrical shock, injury or fire could occur. Make sure the battery pack is turned off and are completely dry before charging.

## WARNINGS

- It is safe to leave the charger connected to the battery pack when charging is complete or when charger power is off. To conserve energy, unplug the unit when not in use.
- Operation of the charger with battery packs other than those intended is dangerous and could result in damage to the battery or charger.
- Model numbers and ratings are shown on the rear label of the charger. This charger is intended to be correctly oriented in a vertical or floor plug socket.
- This charger is for indoor use only.
- Use only in dry locations.
- Charger contains no user-serviceable parts. Do not attempt to open this product; replace if damaged.
- Keep the charger away from fire and other sources of heat.

# FLASH DIFFUSER 0591.3

## USING THE DIFFUSER

The white diffuser can be secured to the front of the DS160 Strobe when softer lighting or a coverage angle of 100° is desired.

The diffuser reduces the DS160's light intensity by one full f-stop.

## DIFFUSER INSTALLATION AND REMOVAL

1. Position the Diffuser Cut-outs over the DS160's Diffuser Retention Tabs.
2. Press down lightly until the diffuser is flush against the strobe face.
3. Rotate the Diffuser Installation Posts either direction until the Posts stop against the strobe's Diffuser Retention Tabs.
4. Reverse process to remove the Diffuser.

A lanyard or string can be attached to the diffuser by threading it through the two Lanyard Holes near its edge. Attach the other end to the strobe to prevent accidental loss.

**Flash Diffuser**

**DS160 Strobe**

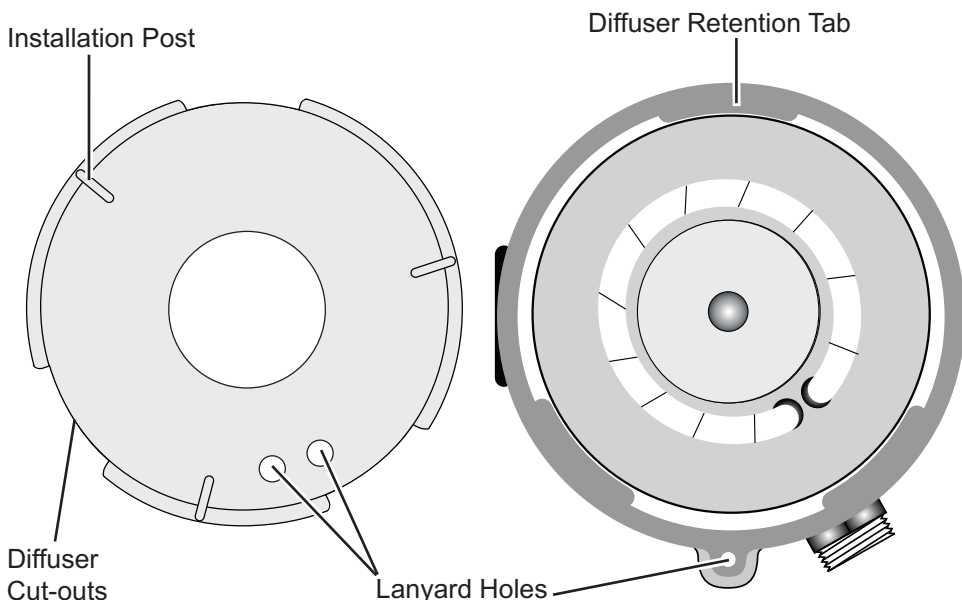

# ARM SYSTEMS / STROBE MOUNTS

## IKELITE ARM SYSTEMS

Ikelite offers several arm choices compatible with the DS160. The arm and strobe mount are NOT supplied with the strobe. For additional information go to [www.ikelite.com](http://www.ikelite.com)

**Caution:** Ikelite arm systems are designed for underwater use. Be careful when transporting the system above water since some camera trays and arm adjustments may be unable to support the weight of the strobe(s) above water.

## IKELITE MOUNTS

An optional paddle-type or ball-type mount can be mounted to the underneath side of the strobe. The mount slides into the strobe base and is secured with a screw (supplied with optional mount). Make sure to slide the mount into the strobe base until it stops. Be careful to not cross-thread the screw when tightening the mount. The DS160 Black Shroud can be rotated slightly to gain better access to the strobe base with a screwdriver.

Although not necessary, you can apply a small amount of Ikelite lube around the screw threads before attaching the strobe mount. Use Ikelite lube only (supplied with the DS160 Strobe). This will reduce the possibility of seizing and allow removal of the screw should the mount need to be removed. Removing the mount for long storage periods will also reduce the possibility of seizing.

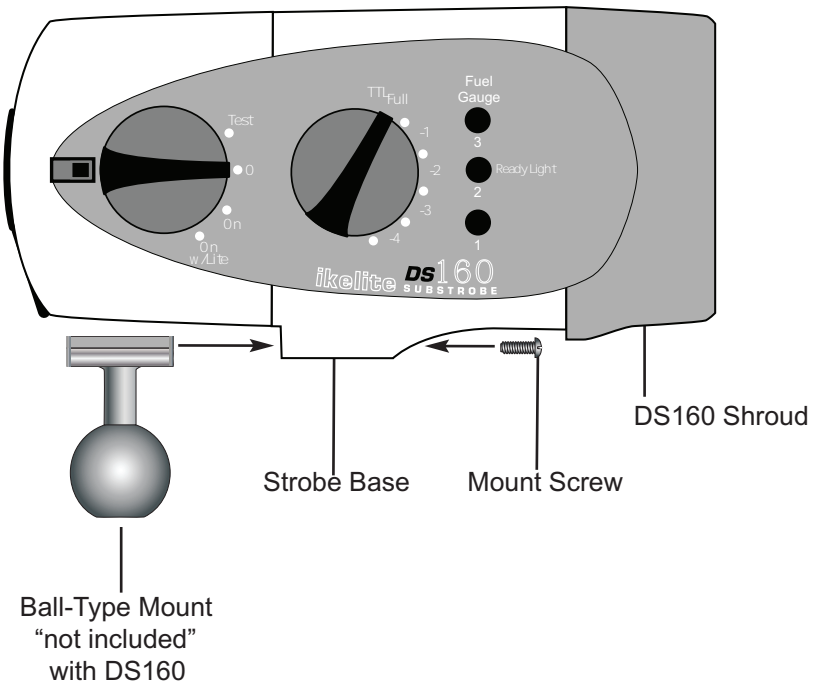

# STROBE CONNECTION

The female bulkhead connector permits different Ikelite sync cords, EV Manual Controller or a Fiber Optic Adapter to be connected to the strobe. These connectors relay signals from the camera to the strobe to trigger the flash.

The removable waterproof bulkhead cap seals the bulkhead connector when nothing is connected to the DS160. The strobe's bulkhead connection must be sealed to remain waterproof (page 14).

## Caution:

- **Do not** leave the sync cord or sensor connected to the camera or strobe for prolonged periods as electrolysis could occur and make removal of the equipment impossible.
- **Do not** disconnect the sync cord or sensor from the housing or strobe when underwater or when wet. These items are not waterproof when disconnected.
- Make sure there is no debris on the sync cord o-ring and the sync cord connector is aligned properly when attaching to the strobe bulkhead (page 14).

## CONNECTION TO STROBE

To connect either a sync cord or sensor to the DS160 Strobe, follow these instructions:

1. Turn the strobe to OFF and make sure all components are dry. Clean and lightly lubricate the stem o-ring and the bulkhead connector threads. Check the o-ring for nicks or cuts.
2. Note the positioning of the receptacles and pins on the end of the cord. Properly align the end of the cord and insert it into the strobe bulkhead connector. When using the 4103.51 cord, which connects an Ikelite housing to an Ikelite Strobe, both cord ends are identical; either end can be connected to the strobe.
3. The connector threads are very fine; do not cross thread. If it is difficult to turn the knurled retaining ring on the cord or sensor, you are likely cross-threading. This can make removal of the strobe or sensor impossible.

Hand-tighten the knurled retaining ring on the cord or sensor. Push the end of the cord further into the bulkhead connector and continue to tighten the knurled retaining ring. **Do not** use pliers or a tool when tightening. It could damage the cord or strobe.

# STROBE CONNECTION (illustration)

## DS160 Strobe

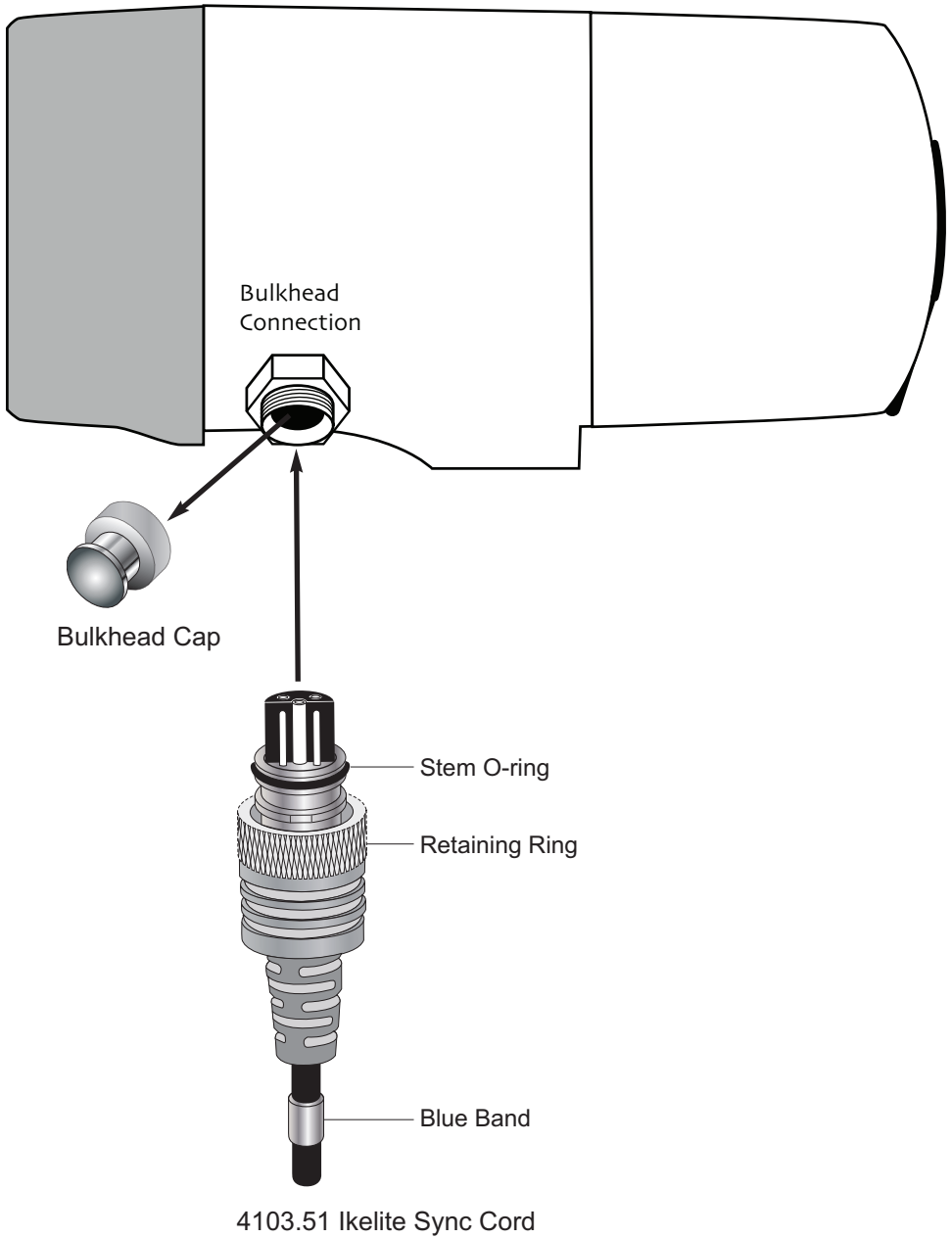

## USING AS A TTL HARD-WIRED STROBE

For use with the following types of systems:

- Ikelite housings for digital cameras with TTL conversion circuitry
- Ikelite housings for film cameras
- Nikonos V, RS cameras
- Non-Ikelite housings for digital cameras and compatible TTL adapter

Connect the strobe using an appropriate Ikelite TTL sync cord. Digital DSLR cameras require the use of a Digital TTL sync cord. These cords are designated by a blue band at one end. The DS160 may be used in TTL(Auto) or manual exposure modes.

TTL (thru-the-lens) exposure automatically compensates for aperture, distance and filters. Because there's such a wide range of apertures and subject distances, photographers wanting to easily balance lighting and control close-up photographer should select the TTL(Auto) exposure mode. When the strobe fires, the camera reads the light and signals the strobe to turn off when the exposure is correct.

Strobe output can be adjusted in TTL(Auto) mode using either exposure compensation built into the camera or an exposure compensation module in the back of the housing (if applicable).

If an exposure compensation module is featured in the back of the housing, strobe output may be controlled manually while the strobe itself is left in TTL(Auto) mode. In order to use the manual exposure modes on the strobe itself, the housing module must be set in a manual position.

When using a non-Ikelite TTL adapter or third party conversion circuitry, please refer to the product's instructions for help in using the DS160 with this setup.

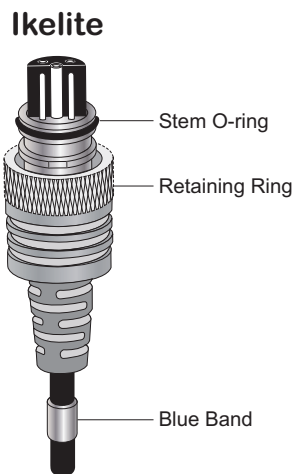

## USING AS A HARD-WIRED STROBE WITHOUT TTL

For use with the following types of systems:

- Ikelite housings for digital cameras with external strobe connector but without TTL conversion circuitry
- Non-Ikelite housings for digital cameras with Nikonos-style strobe connector

Connect the strobe using an appropriate Ikelite sync cord. The DS160 must be used in manual exposure modes. Strobe output is not automatically adjusted for proper exposure when set to TTL(Auto) mode.

# AIMING THE STROBE

## AIMING THE STROBE

Use the modeling light to aim the strobe. Look thru the camera's viewfinder, and aim the strobe so that the modeling light shines in the center of your picture area. If your subject distance greatly changes, you should recheck the positioning of the strobe.

When using auto-focus cameras, the modeling light may be required in low light levels to illuminate your subject to allow the camera to auto focus.

Always hold onto the center of the strobe when repositioning. Do not reposition the strobe by holding the back of the battery pack.

## DS160 Strobe

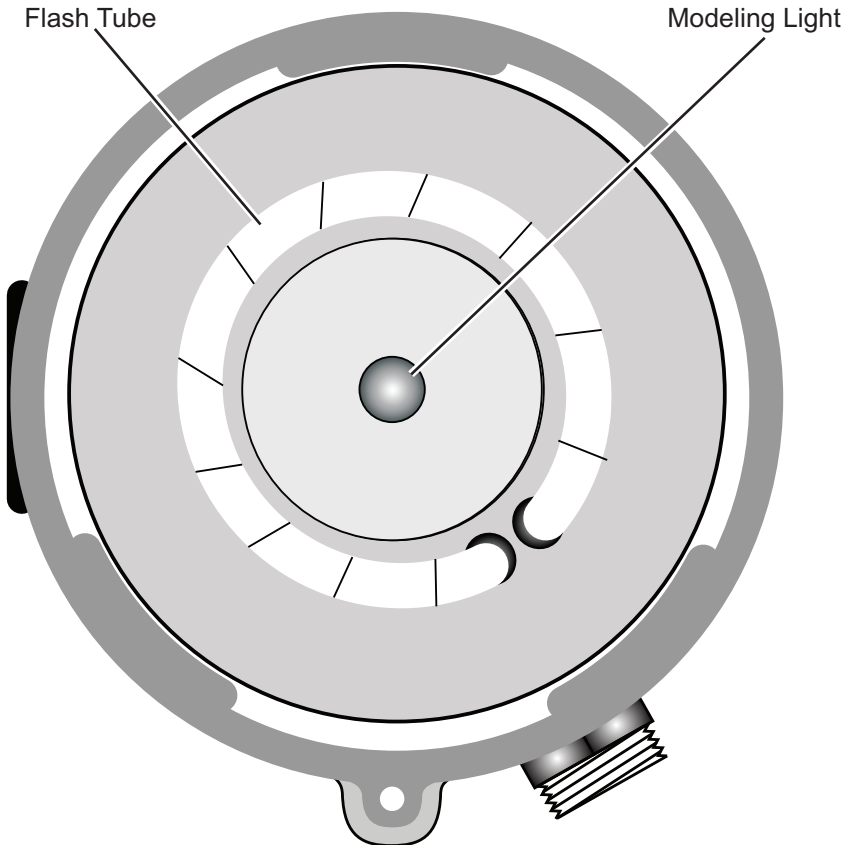



# SWITCHES / FUEL GAUGE

The DS160 features separate switches for power on/off and firing modes. The arrow on the switch points to the selected position.

## ON/OFF SWITCH

**OFF:** The horizontal switch position is OFF. The adjacent tab locks the switch in the OFF position. To unlock, slide the tab away from the switch. Always turn the Strobe OFF before opening the strobe.

**ON:** There are two ON positions. Rotating the switch clockwise to the first ON position turns on the power to the Strobe. Further rotation of the switch clockwise to the second ON position turns on both the power to the Strobe and the modeling light.

**TEST:** Occasionally check the battery capacity by rotating the switch counter-clockwise to the “Batt w/Lite” battery position and referencing the fuel gauge on the side of the strobe. The “Batt w/Lite” battery position also turns ON the modeling light.

## DS160 Strobe

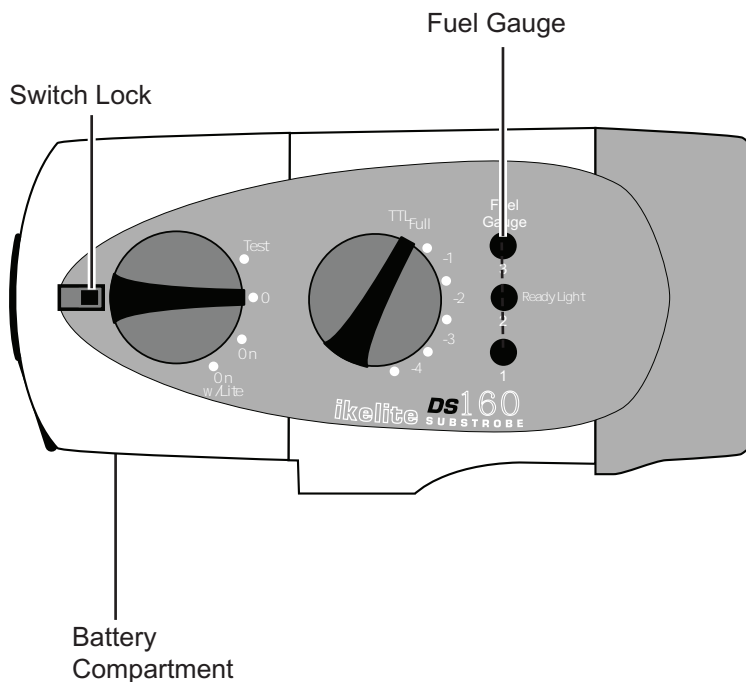

# SWITCHES/FUEL GAUGE (continued)

## FUEL GAUGE

When the switch is rotated to the “Batt w/Lite” position, the fuel gauge on the side of the strobe will display 0, 1, 2, or 3 red LED lights indicating the remaining charge in the battery pack (see below). When no LED's are illuminated, then the battery capacity is low and you may have less than 75 full power flashes remaining. For general guidelines, refer to the following list:

- 3 LED's - above 75%
- 2 LED's - above 50%
- 1 LED - above 25%
- No LED - less than 25%

## CONFIDENCE SIGNAL

The DS160 strobe features a confidence signal indicator light that will glow if the strobe receives a TTL quench signal. The #3 LED on the fuel gauge will glow GREEN for three seconds if the DS160 strobe quenches. This green confidence light illuminates only in the TTL exposure mode when used with compatible TTL systems.

## FIRING MODE SWITCH

Multiple firing modes are featured: TTL/Auto and 9 fractional power settings from the Full power setting: Full, -1/2, -1, -1 1/2, -2, -2 1/2, -3, -3 1/2, -4, -4 1/2.

**TTL(Auto) - Thru-The-Lens/Auto Exposure:** The camera automatically signals the strobe to turn off when the exposure is correct. The camera must feature compatible TTL(Auto) exposure to utilize this mode on the DS160 when connected directly to the camera. (See “Using as a Hard-Wired TTL Strobe” section). The TTL(Auto) firing mode **MUST** be selected when connecting the optional EV-Controller 4100.6.

**Full - Full Power Manual Exposure:** The strobe fires at full power each time. You must select the correct exposure manually. Set the camera aperture based on the subject distance (see “Exposure Guide” section).

**Fractional Power Settings:** Select the appropriate power setting to manually balance the strobe output for available light. Select a fractional power setting when the strobe-to-subject distance is fixed and the manual full power setting would over-expose with the camera's selected aperture. The difference between **each power setting** is one-half an f-stop; moving from Full power to -1/2 decreases the light output by one-half an f-stop. Changing the power setting does not alter the coverage angle.

# STROBE READY LIGHT

## STROBE READY LIGHT AND TTL HOUSING

The Ikelite DS160 Strobe features a ready light that glows red when the DS160 has recycled and is ready to fire its flash again.

The middle #2 LED on the fuel gauge functions as the visual ready light.

The #3 LED on the fuel gauge will glow GREEN for three seconds if the DS160 strobe quenches, indicating that the strobe has provided proper exposure. If no green light appears, check the image for possible under-exposure. When the strobe has recycled again, the ready light will again glow red indicating that the strobe is fully powered and ready to fire. If the strobe ready light does not glow red, the batteries may be expended.

Your camera's ready light "lightning bolt" in the camera viewfinder may blink while the DS160 is recycling and then glow solid when the DS160 is fully charged. Nikon DSLRs and older Canon DSLR models such as the 20D and Rebel XT will always display a solid glow "lightning bolt" regardless of the strobe cycle.

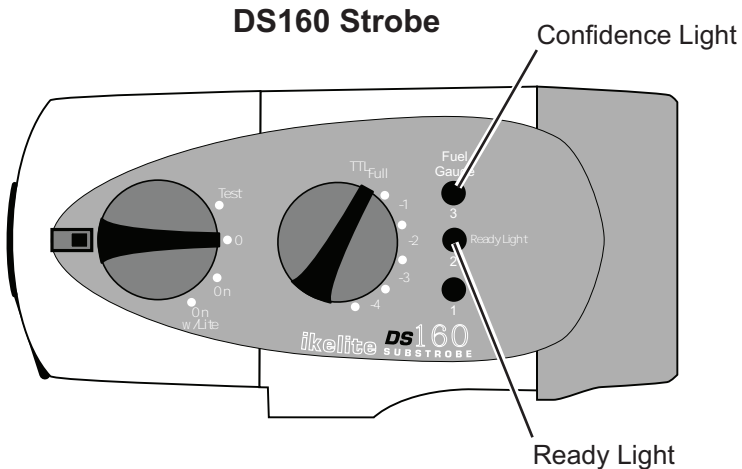

## CAMERA READY LIGHT - Triggered via Sync Cord

When using a TTL/Auto exposure camera (film or digital) in an Ikelite TTL compatible housing connected to the DS160 strobe by sync cord, the flash ready light in the camera viewfinder and the DS160 ready light will both glow when the Strobe has recycled and is ready to fire.

If the Ikelite housing does not feature TTL compatible circuitry, then the ready light in the camera viewfinder would not be triggered when the strobe has recycled.

# RECOMMENDATIONS

## VISUAL INSPECTIONS

Visual inspections are important. Take the time to examine the entire assembled setup (strobe, camera housing, arms, etc.) above water. An improper seal or loose connection can cause a lot of damage. Always check for leaks once you place the equipment in the water.

## INSURANCE

It is recommended that you add an **all-risk floater** to your homeowner's and/or renter's insurance policy to cover your equipment against loss or damage. While the Ikelite DS160 Strobe has a limited warranty against manufacturing defects, it does not cover customer neglect.

## TIPS

- Photograph through as little water as possible; move in close. Maximum recommended shooting distance underwater is 1.8m (6').
- Use the diffuser for softer lighting or a coverage angle of approximately 100°.
- If possible, measure the light with a meter and set the camera aperture accordingly. A narrower aperture darkens the background; a wider aperture lightens it.
- Add a second DS160 Strobe for more natural looking photos and wider angle of coverage when shooting both still and video images. Add a second DS Strobe using either the EV Manual Controller 4100.6 or an appropriate dual sync cord.
- Purchasing a spare Li-ion Battery Pack 4067 is recommended if you dive often. Weak batteries are the cause of many strobe and camera problems.
- **Do not** fire the strobe more than 15 times above water in rapid succession. If this does happen, allow the DS160 to cool off for at least 10 minutes before resuming photography.

## LUBRICANT

- Use **only** Ikelite brand silicone lubricant with Ikelite brand o-rings; other brand lubricants can cause the Ikelite o-rings to swell in size.
- **Do not** use spray lubricant; it can crack the plastic parts of the strobe.
- Ikelite brand silicone lubricant is provided for the sync cord stem o-ring and the bulkhead connector threads. Use only enough lubricant to lightly cover the area being applied; wipe off any excess with a clean cloth.
- Lubricant only reduces friction; it is not a sealant.

# MAINTENANCE

Your Ikelite DS160 Strobe should be given the same care and attention as your other photographic equipment. After using your strobe in water, please follow these instructions to ensure the DS160's longevity and good working order.

## CLEANING AND STORAGE

1. Always rinse the exterior of the DS160 with fresh water after use, especially after exposure to salt water. While rinsing, turn the mode and power switches to free salt or debris that might have accumulated in the DS160 recesses during the dive. The strobe should **NOT** be left unattended in a rinse tank, as it could be damaged by other equipment in the tank. The strobe can be cleaned by soaking it in a mild soapy solution. Use liquid soap; RINSE and DRY the strobe before storage.
2. Check the battery pack o-ring sealing surface for any debris and gently wipe it away with a soft, lint free cloth.
3. Check the DS160 bulkhead connector threads for debris. Gently wipe away with a soft, lint free cloth or a cotton swab to clean the threads. Afterwards, lightly lubricate them.
4. The o-ring 0132.36 is located on the inside rim of the DS160 battery pack. Keep the o-ring and the sealing surfaces clean. **DO NOT** stretch the o-ring when cleaning. It is not necessary to lubricate the o-ring. Never use spray lubricant because it may crack the plastic.
5. Keep the strobe bulkhead connector threads clean and lightly lubricated. Also keep the sync cord o-ring and threads clean and lightly lubricated.
6. Recharge the battery pack after each use; **DO NOT** fully discharge the battery pack because you will shorten the battery life. Store the battery pack fully charged, and recharge the pack for a few hours each month. **DO NOT** disassemble the battery pack.
7. The strobe is factory sealed; **DO NOT** disassemble.

In addition to these procedures, it is strongly recommended that this strobe be returned to Ikelite periodically for inspection and water pressure testing. Ideally your DS160 should undergo this process every two years or 100 dives, whichever comes first.

### Caution:

- The DS160 bulkhead connector is not waterproof and must be capped when not connected to a cord or sensor. Using a DS160 underwater with the bulkhead connector uncapped or unconnected will cause the strobe to flood. **DO NOT** continue to use a flooded strobe; return to Ikelite for repair.
- Disassembly will void your Ikelite DS160 limited warranty.
- **DO NOT** continuously fire the strobe more than 15 times above water in rapid succession. If this does happen, allow the strobe to cool down for at least 10 minutes.

# TROUBLESHOOTING

## STROBE WILL NOT FIRE

1. Make sure the battery pack is fully charged.
2. Check the DS160 ready light. Turn the strobe's mode switch to OFF and then back to ON. Make sure that the switch has actually clicked into position.
3. Check the mode switches on the camera and strobe.
4. Check the cord connections at the camera and strobe.
5. When using a sync cord between the camera and strobe, disconnect the cord from the camera but leave the cord connected to the strobe. Then, use the two ends of a bent paper clip to connect different receptacles on the flash cord contacts, as detailed in the diagram below. This process is commonly known as "shorting," which creates a temporary circuit that can test-fire the strobe.



**Caution:** When creating a circuit via paper clip, or "shorting," pay close attention to which two receptacles you connect. If you short across the wrong receptacles on a TTL sync cord, you may damage the DS160's electronics.

The specific receptacles to connect with the paper clip vary based on the type of cord you own. Please refer to the diagram of two types of flash cord contacts.

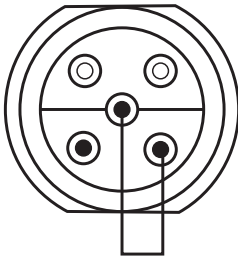

Ikelite

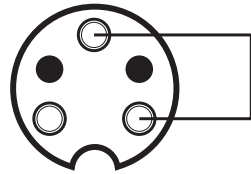

Nikonos

**Ikelite TTL Cord:** Point the raised half-circle at the end of the cord encompassing the receptacles towards you, per the above diagram. Place one end of the paper clip on the center receptacle and one end on the lower right hand receptacle. The DS160 should flash.

**Nikonos TTL Cord:** Point the indexing groove at the end of the cord towards you, per the above diagram. Place one end of the paper clip on the top most, center receptacle and one end on the lower, right hand receptacle. The DS160 should flash.

If the DS160 flashes, the source of the problem lies somewhere in the camera.

If the DS160 does not flash, please send both the strobe and cord used in the test to an authorized Ikelite dealer, or to Ikelite; see "Technical Support" on page 23.

**Do not** attempt to repair the strobe or cord yourself. This may cause further damage and void your Ikelite limited warranty.

## **AIRLINE TRAVEL**

The Li-ion Battery Pack 4067 complies with packing instructions 967 for UN 3481 (rechargeable Li-ion packaged with equipment) as required by the ICAO Transport of Lithium Batteries Guidance Document and IATA Dangerous Goods Regulations. The Li-ion battery used in this strobe contains an ELC of less than 2 grams and is less than 100Whr. The enclosed lithium ion batteries are tested and comply with the UN Model Regulations, Manual of Test and Criteria, Part III, subsection 38.3. ADR Class 9.

## **CUSTOMER SUPPORT**

Customer support is available through an Authorized Ikelite Dealer or directly through Ikelite Customer Service. For a listing of dealers and distributors worldwide, please visit the Ikelite website at [www.ikelite.com](http://www.ikelite.com).

Ikelite Customer Service  
50 W. 33rd Street  
Indianapolis, IN 46208 USA

Email: [ikelite@ikelite.com](mailto:ikelite@ikelite.com)  
Phone: +1 317 923 4523

When contacting customer service, please have your product serial number and date of purchase available to ensure the fastest possible resolution.

## **LIMITED WARRANTY**

The Ikelite DS160 Strobe Head is warranted against any manufacturing defects for a period of two (2) years from the original date of purchase. The DS160 Li-ion Battery Pack is warranted against any manufacturing defects for a period of one (1) year from the original date of purchase. All other claims of any nature are not covered. Except as mentioned above, no other warranty expressed or implied applies to this Ikelite product.

To obtain warranty service, contact your Authorized Ikelite Dealer or Ikelite Customer Service.

# PRODUCT REGISTRATION

Please visit [www.ikelite.com](http://www.ikelite.com) to register your Ikelite Digital Strobe within 15 days of purchase.

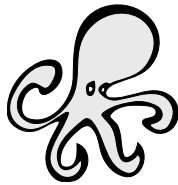

**Ikelite Underwater Systems**  
50 West 33rd Street  
Indianapolis, IN 46208 USA

[www.ikelite.com](http://www.ikelite.com)