

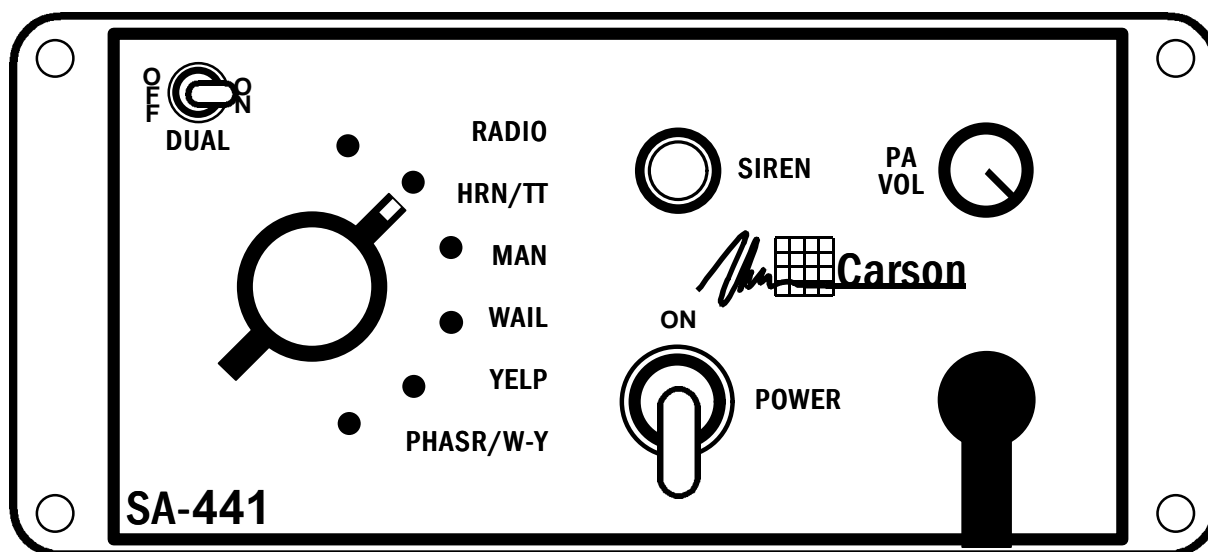

Carson

MANUFACTURING COMPANY, INC.

SA-441 DUAL REMOTE SIREN AMPLIFIER



INSTALLATION AND OPERATING INSTRUCTIONS

5451 N. Rural Street
Indianapolis, IN 46220
Phone: (888) 577-6877
Fax: (317) 254-2667
Website: www.carsonsirens.com

TABLE OF CONTENTS

TABLE OF CONTENTS	2
SPECIFICATIONS	3
NOTICE.....	3
GENERAL DESCRIPTION.....	4
INSTALLATION.....	5
SAFETY PRECAUTIONS	5
UNPACKING	5
OPTION SWITCHES.....	6
MOUNTING – Control Head.....	6
ELECTRICAL CONNECTIONS – Control Head.....	6
MOUNTING – Amplifier	8
ELECTRICAL CONNECTIONS - Amplifier	8
SIREN TESTING.....	9
OPERATION	10
GENERAL.....	10
SELECTOR SWITCH	10
SIREN SWITCH	10
MICROPHONE (PA Override)	11
PA VOL.....	11
AUXILIARY INPUT	11
RADIO VOLUME	11
OVERRIDE FUNCTIONS	11
HORN RING CYCLER (Optional).....	11
SERVICE.....	12
PROBLEMS.....	12
PARTS.....	13
RETURN.....	13
LIMITED WARRANTY.....	14
CONTROL HEAD INSTALLATION TEMPLATE.....	15

SPECIFICATIONS

Input Voltage	11 - 16 VDC (negative ground)				
Input Current	17 AMPS (@14.0 VDC - dual 100W speakers)				
Standby Current	Less than 250 mA				
Audio Frequency	200Hz - 10 kHz + 3db				
Audio Distortion	Less than 3% (@1 kHz - dual 100W speaker)				
Audio Output	80 watts (@14.0 VDC - dual 100W speaker)				
Audio Input	400 ohms \pm 10%				
Output Power	210 WATTS RMS MAX. (15.0 VDC - dual 100W speakers)				
Siren Frequency	700Hz - 1500Hz (Two-Tone and Horn = 435 & 585Hz)				
Tones / Cycle Rates	Horn	Wail	Yelp	Phaser	Two-Tone
	109 CPS	13 CPM	190 CPM	15 CPS	60 CPM
High Voltage Protection	16 - 18 VDC will cause siren output to cease, resume at normal				
Short Circuit Current	50 AMPS (supply circuit must be capable of supplying this)				
Operating Temperature	-15° F to +140°F				
Controls	6-position rotary mode switch (Phaser/Wail-Yelp, Yelp, Wail, Manual, Horn/Two-Tone and Radio). Dual siren control toggle switch. Momentary push-button Siren switch. Front panel mounted PA volume control, Radio adjust on amplifier Auxiliary input for positive or negative connection. 8-position DIP switch option selector.				
Connections (10-Pin Conn)	(2) Positive, (2) Negative, (3) Speaker, (2) Radio, Control				
Size	Control Head: 6-1/4" W x 2-7/8" H x 1" D Amplifier: 8" L x 6-3/4" W x 2-1/8" H				
Weight	6 LBS.				

NOTICE

Due to continuous product improvements, we must reserve the right to change any specifications and information, contained in this manual at any time without notice.

Carson Manufacturing Co., Inc. makes no warranty of any kind with regard to this manual, including, but not limited to, the implied warranties of merchantability and fitness for a particular purpose.

Carson Manufacturing Co., Inc. shall not be liable for errors contained herein or for incidental or consequential damages in connection with the furnishing, performance, or use of this manual.

GENERAL DESCRIPTION

The SA-441 Dual Siren Amplifier is a premium unit designed for dual 100W speaker use from a 12 volt DC power source (negative ground). The control head is only 1 inch deep and can be installed in minimum clearance areas. Connection between the control head and amplifier is via a single lead wire with common ground.

A 6-position rotary switch controls the primary operating modes of Phaser, Yelp, Wail, Manual, Horn and Radio. A Dual siren control switch provides additional modes, including dual Wail, dual Yelp, Wail and Yelp, dual Phaser, dual Horn, and Two-Tone. A Siren control button is provided for control of the output tone when in the Manual mode, and control of Horn and Yelp Overrides, depending on the function switch setting. An independent toggle switch controls power. A hole is provided in the amplifier to adjust Radio volume.

Depending upon the version, the microphone may or may not be directly mounted to the control head. Units with an "F" suffix have the microphone permanently mounted to the faceplate. Units with an "FX" suffix are provided with an extension harness and connectors for remote mounting of the microphone.

An auxiliary input is provided for connection to a positive or negative horn ring circuit or switch, performing the same function as the Siren button.

An 8-position DIP switch on the amplifier allows selection of various options: Two-Tone to replace Phaser, Phaser disable, Horn disable, dual mode disables and Horn Ring Cyclers (HRC), which allows cycling through Wail, Yelp, Phaser and Standby by tapping the horn ring when the function switch is in the Horn position. The front panel is backlit with LED's for night visibility.

This durable unit utilizes short circuit, high voltage, and reverse polarity protection systems for maximum service life over a wide temperature range. Two separately fused amplifiers provide redundancy, and the unit will operate with only one amplifier functioning.

INSTALLATION

Proper installation of the unit is essential for years of safe, reliable operation. Please read all instruction **before** installing the unit. Failure to follow these instructions can cause serious damage to the unit or vehicle and may void warranties.

SAFETY PRECAUTIONS

For the safety of the installer, vehicle operator, passengers and the community please observe the following safety precautions. **Failure to follow all safety precautions and instructions may result in property damage, injury or death.**

Qualifications - The installer must have a firm knowledge of basic electricity, vehicle electrical systems and emergency equipment.

Sound Hazards - Sound levels produced by attached speakers can cause permanent hearing loss. Never operate this unit without adequate hearing protection for you and others in the area. (OSHA 1910.95)

Mounting - Mount the control head for easy access by the vehicle operator. DO NOT mount in air bag deployment area. Assure clearances before drilling in vehicle.

Wiring - Use wiring capable of handling the current required. Make sure all connections are tight. Route wiring to prevent wear, overheating and interference with air bag deployment. Install and check all wiring before connection to vehicle battery.

Testing - Test all siren functions after installation to assure proper operation. Test vehicle operation to assure no damage to vehicle.

Keep These Instructions - Keep these instructions in the vehicle or other safe place for future reference. Advise the vehicle operator of the location.

UNPACKING

Inspect contents for shipping damage. If found **alert carrier immediately.** Contents should include control head with attached microphone, amplifier, control head wiring harness, removable pressure connector, microphone bracket with 2 screws and these instructions. Contact supplier immediately if any components are missing.

Note: On "FX" units the microphone is detached and a microphone extension cable with connectors is additionally supplied.

AMPLIFIER ELEMENTS

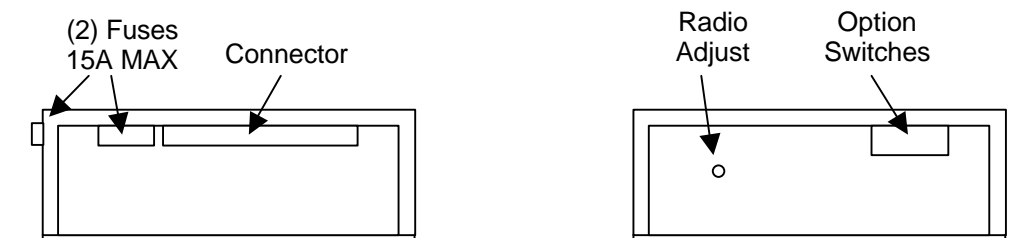

OPTION SWITCHES

Various options can be controlled by turning on or off any of 8 DIP switches exposed in the amplifier.

- Switch 1 On:** **Two-Tone** - Two-Tone replaces Phaser function.
- Switch 2 On:** **Dual Phaser Disable** – Provides single Phaser signal only.
- Switches 1 & 2 On:** **Phaser Disable** - The Phaser function is disabled.
- Switch 3 On:** **Horn Disable** - The Horn function is disabled.
- Switch 4 On:** **Horn Ring Cycler option (HRC)** - This option allows selection of Wail, Yelp, Phaser and Standby by repeatedly tapping the Siren button, horn ring or other switch connected to the AUX input. It also provides Horn operation by pressing and holding the switch or ring. Select this option by turning on the switch labeled “HRC”.
- Switch 5 On:** **Dual Horn Disable** – Provides single Horn signal only.
- Switch 6:** **Not Used.**
- Switch 7:** **Not Used.**
- Switch 8:** **Not Used.**

MOUNTING – Control Head

Select a mounting location in an area such as the dash or overhead console. Choose a mounting location convenient to the operator and away from any air bag deployment areas. Inspect behind mounting area for clearance. Allow 1 $\frac{3}{4}$ " of depth to accommodate the control head and cable(s). Consider wire routing and access to connections, as well as microphone bracket placement.

Use template (back page) for marking hole and cutout locations. Connect control head cable to back of unit and route leads through cutout. Make all electrical connections (See ELECTRICAL CONNECTIONS – Control Head), and then use #6 screws for mounting the control head (not supplied).

MOUNTING - Microphone Extension Harness (“FX” model only)

Select a mounting location for the microphone connector, verifying adequate cable length. Allow 1-3/4" clearance behind connector to prevent sharp bends in the harness. Drill or punch a 5/8" diameter hole for mounting. Remove mounting nut and washer from connector. Insert the connector into the hole and secure it using a 3/4" socket to tighten the nut. Connect harness to the control head as shown prior to final installation of head.

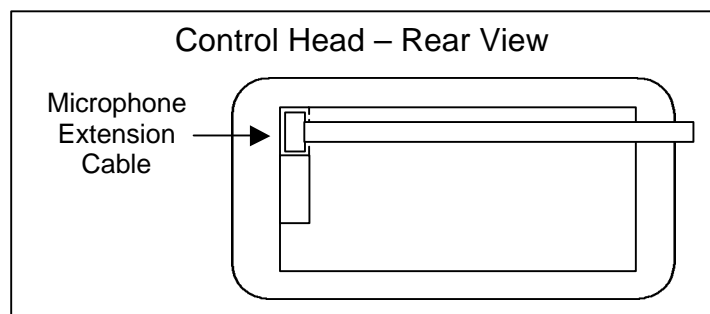

ELECTRICAL CONNECTIONS – Control Head

All control head leads can be extended with #22 AWG or larger lead wire.

Black: Negative - Connect to same ground or negative supply as amplifier.

Red: Positive - May be connected to 12 volt D.C. supply. It is recommended that the lead be connected to the accessory output of the fuse block. This provides additional protection of a fused input to the control head.

Yellow: Lights - This lead may be connected to the dash lights or to the red power lead. Connecting to the dash lights will turn on the panel lights whenever the dash lights are on. When connected to the red lead, make sure that the ignition switch controls the power to that connection. This prevents the panel lights from being continuously on.

White: Control - Connect white leads from amplifier and control head. The connection may be extended with any size wire. Route this lead away from the transmitter antenna lead to prevent R.F. interference being fed to the siren amplifier.

Green: Auxiliary Input - Used for Siren control. Performs same function as Siren button. Connect to a normally open switch or to horn ring circuit. Circuit may connect to either positive or negative. When connected to horn ring circuit, use a SPDT switch to connect horn ring to either vehicle horn or to manual control circuit.

NOTE: Permanent disconnection of the vehicle horn is NOT recommended.

NOTE: be sure to cut lead short if not used and insulate with electrical tape.

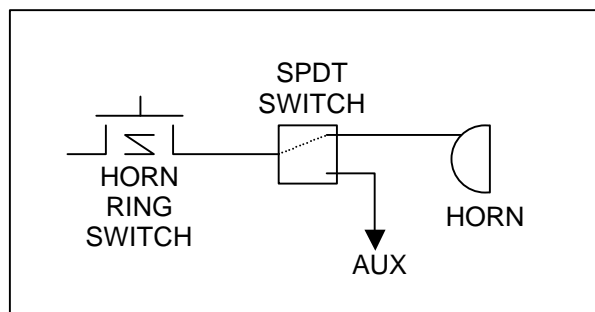

MOUNTING – Amplifier

Select a location for the amplifier in an area such as the driver compartment firewall, under a seat, etc. Mounting the amplifier in the engine compartment or in an area directly exposed to weather is not recommended. Assure adequate ventilation to prevent overheating. Allow clearance for wiring and radio adjustment. Inspect behind mounting area for clearance. Mark the location of the mounting holes to be drilled.

Drill 4 holes (up to 1/4" diameter) to mount the amplifier to the vehicle. Install the removable pressure connector and make all electrical connections before final mounting (See ELECTRICAL CONNECTIONS – Amplifier). The connector can be secured with the two locking screws. Then mount the amplifier to the vehicle using appropriate hardware (not supplied).

ELECTRICAL CONNECTIONS - Amplifier

Electrical connections to the amplifier are made using a removable pressure connector located on the amplifier. A label on the unit identifies the terminal function. You should install the connector on the unit before wiring. If the unit needs service the connector can be easily removed without unwiring the connector. The power supply of the unit must be capable of delivering peak currents up to 50 amps for adequate short circuit protection and reliable operation. The preferred source is directly at the vehicle battery. The unit is internally fused.

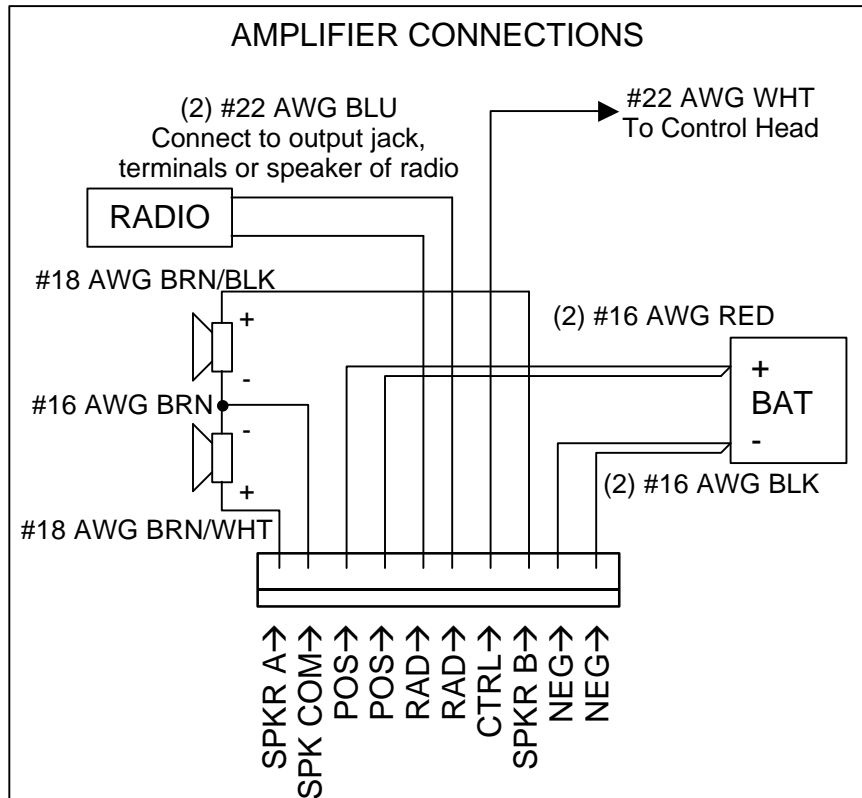

Attach leads by stripping 3/8", inserting into connector and clamp by tightening screw. Make sure the screw is tight and the wire can't be pulled out. **Failure to adequately tighten the screw can result in improper operation or burning the connector and wire.**

Wire Size and Termination - The diagram shows the minimum wire size used for each connection, along with recommended lead color. If the wire is longer than 10 ft. use the next larger wire size. The power lead pairs can be extended with single #12 AWG lead wire. Use only high quality crimp connectors for installation on the vehicle.

Please note that three leads are connected to the speakers – one common lead to the negative of both speakers and one lead to each positive speaker terminal. This is necessary for dual mode operation.

SIREN TESTING

Before re-connecting the battery in the vehicle make sure that the siren is turned off. Observe polarity when re-connecting.

Caution: Hearing protection should always be used when testing any siren, especially indoors. The sound levels produced by the speakers may cause hearing loss.

The following procedure should be used to test the siren:

1. With the function selector set to the HRN/T-T position and Dual switch off turn on the power switch. Nothing should be heard from the speakers.
2. Press the Siren button. The speakers should emit a simulated Air-Horn sound while the button is pressed. (If the auxiliary lead is used check the appropriate switch and/or horn-ring operation. The result should be the same.)
3. Set function selector to PHASR/W-Y and turn on the Dual switch. You should hear Wail out of one speaker and Yelp out of the other.
4. Test the microphone operation by pressing the microphone button and speaking. The noise-canceling microphone should be held close to the lips for proper operation. Use the volume control to adjust the sound level.
5. If the Radio input leads are connected test this function by setting the function switch to this setting. Adjusting a control through a hole in the amplifier sets the sound level.

OPERATION

GENERAL

This unit is designed for easy operation under the stress associated with high-speed pursuit. Most siren functions are accessible with one simple motion without repetitive activation of switches or automatic timed switching that can interfere with desired operation.

SELECTOR SWITCH

The 6-position rotary selector switch controls the primary operating function of the siren.

DUAL SWITCH

The Dual switch controls the signal to the two amplifiers. With the switch off the amplifiers produce a common signal to the speakers. With the switch on independent siren signals are produced by each amplifier. Selector switch labeling reflects these differences.

Dual switch off:

Phaser - A very rapidly changing tone used at intersections or in highly congested areas. Can be optionally disabled or replaced with Two-Tone.

Yelp - A rapidly changing tone used in congested areas.

Wail - A slower changing tone used on highways.

Man - Or Manual, the siren tone is controlled manually by the Siren button or auxiliary input.

Horn - A standby mode that allows Horn Override.

Radio - Also known as Radio Repeat, this function amplifies a radio speaker input for re-broadcast outside the vehicle. No siren tones are available in this position.

Dual switch on:

Wail and Yelp – One speaker produces Wail and the other produces Yelp.

Dual Yelp – Two independent Yelp signals.

Dual Wail – Two independent Wail signals.

Dual Manual – Two independent Manual signals controlled by the Siren button.

Two-Tone – Or Hi-Lo, a common European tone.

Radio – Same operation as with Dual switch off.

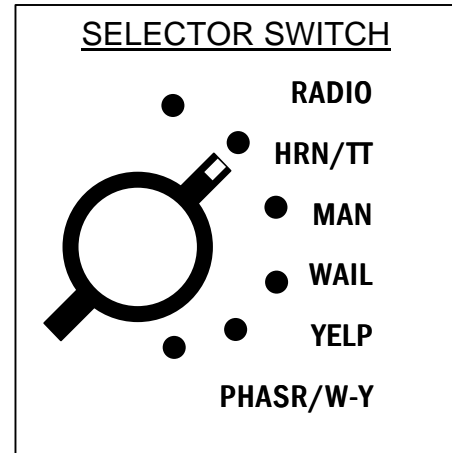

SIREN SWITCH

This momentary push-button switch provides various control functions in conjunction with the Selector Switch. These functions are manual tone control in the Manual position, Horn Override in the Phaser, Yelp and Horn positions, and Yelp Override in the Wail position. It can optionally control Horn Ring Cyler operation in the Horn position if the HRC option is selected.



MICROPHONE (PA Override)

The attached noise-canceling microphone is used for public address operation and overrides any function when the button on the side is pressed.

PA VOL

This control adjusts the PA volume. With the vehicle parked, set the PA volume to the maximum level with no feedback (squeal).

**AUXILIARY INPUT**

During installation an auxiliary input may be connected to the horn ring or other switching device. It provides the same operation as pressing the Siren button.

RADIO VOLUME

The radio repeat volume level is set using an adjustment on the side of the amplifier. Set the Selector Switch to the Radio position and turn on the power. With the radio volume set to normal level, adjust the siren radio repeat control to the desired level.

OVERRIDE FUNCTIONS

In addition to PA Override, two other override functions are available and controlled by the Siren button or auxiliary input.

Horn Override - With the Selector Switch in the Phaser, Yelp or Horn positions the Siren button or auxiliary input activates a simulated air-horn tone. This can optionally be disabled.

Yelp Override - With the Selector Switch in the Wail position, pressing the Siren button or activating the auxiliary input toggles between the Wail and Yelp function.

Phaser Override – With the Dual control switch on Phaser override is available instead of Horn override in the Wail-Yelp and Wail selector switch positions. Horn override replaces Phaser override if Phaser is disabled.

HORN RING CYCLER (Optional)

During installation, the auxiliary input may be connected to the horn ring or other switching device, and the HRC option selected. With the Selector Switch set to the Horn position, the horn ring or Siren button can be tapped repeatedly to select the Wail, Yelp, Phaser and Standby tones or modes in succession. Pressing and holding the horn ring or Siren button operates the Horn tone without changing the basic tone selection.

In Dual mode HRC additionally includes Wail-Yelp output as one of the modes.

SERVICE

This unit is designed to provide years of reliable service under even the worst conditions. Many times there may appear to be a problem with the unit when the true problem is in the speaker(s) or improper installation. The following chart shows typical symptoms and possible causes.

A blown rear panel fuse doesn't necessarily mean that the unit is bad. If a speaker or speaker lead is shorted this fuse will blow before the unit is damaged. Disconnect the SPKR leads and replace the fuse. If the siren emits a sound when in the Yelp position it is OK. Check the speaker(s) or leads for possible shorting.

PROBLEMS

Symptom	Possible Cause	Check
No power	Power switch not turned on Connector loose Fuse blown Loose connection at power source	Does backlighting come on? Do you hear a "pop" when turned on? Is an external fuse or circuit breaker used? Are the negative leads connected to a good ground?
No siren tone - PA works	High Voltage Protection Mic button stuck	The input voltage must be less than 16 volts. Does mic button release properly?
No PA	PA volume not set properly	Have you tried turning the PA volume control?
Distorted siren sound	Speaker assembly loose Intermittent Aux Input connection Low vehicle voltage	Is the speaker bell or tip loose? Is the Aux Input used and wired properly? The input voltage must be greater than 9 volts.
Intermittent siren tone	High Voltage Protection Connector loose Bad power connection Mic button activation Circuit breaker in supply connection	Is the vehicle voltage regulator working properly? Is the connector tight on the back of the unit? Is there a loose connection on a power lead? Is something lying on the microphone? Is a circuit breaker used with at least a 50A rating?
Horn function Or Manual stuck on	Siren switch stuck Aux Input improperly connected	Does the Siren switch return fully when released? Is the Aux Input used and wired properly?
No Radio	Unit not connected to radio Radio volume too low	Is the radio connected properly to the unit? Can you here the radio in the vehicle? Have you tried turning the RAD volume control?
Wrong siren tone	Two-Tone option installed Ground system noise	Is the Two-Tone option switch turned on? Are Control head and amplifier connected to good ground?
Phaser not working	Phaser disabled	Is the Phaser Disable option switch turned on?
Horn not working	Horn disabled	Is the Horn Disable option switch turned on?
Dual switch doesn't work	Only one amplifier working One speaker damaged	Is one fuse on the amplifier blown? Have you tried replacing the speaker?
Constantly blows fuses	Amplifiers wired incorrectly	Are SPKR A and SPKR B wired together?

PARTS

The following parts are available from Carson Manufacturing Company, Inc.:

Part	Description
CP3633	Bracket, Microphone with Screws
CP4732	Control, 1K Vertical Trimmer
CP4834	Control, 1K Ohm Vertical Mini-Pot
CP4833-10	Connector, 10-pin Removable Pressure W/Locking Screws
ATO/ATC 15A	Fuse, 15 Amp Automotive
PS70BL-D	Knob, Selector Switch Knob
G-100-2L	Knob, Volume Control
CP4838	Label, SA-441 Front Panel
CP3040	Lead Asmb, Control Head Cable
CP4816	Manual, SA-410-10F Instruction
CP4750	Microphone, Noise Canceling W/Connector
8025 DRS/CAP	Nut, 1/4-40 Dress W/Cap, Red
SR-15-1	Strain Relief, Microphone
8121D2V40	Switch, Momentary Push Button, Vertical
7101-T-C-Q	Switch, Power Toggle
SS2846	Switch, Mini Toggle
CP3599	Switch, Rotary 6-Pos. Selector, Vertical
CP4119	Transistor, TIP36C Power

RETURN

If you have any questions concerning this or any other Carson product, please contact our **Technical Service Department** at (888) 577-6877. Many issues can be handled over the phone. We can also be reached via e-mail at **service@carsonsirens.com**

If a product must be returned for any reason, please contact our Technical Service Department to obtain a Returned Merchandise Authorization number (RMA#) before you ship the product to Carson. Please write the RMA# clearly on the package near the mailing label. Be sure to provide a return address, contact and phone number, along with a brief description of the problem.

LIMITED WARRANTY

Carson Manufacturing Company, Inc. warrants this new product to be free from defects in material and workmanship, under normal use and service, for a period of five (5) years from the date of delivery to the first user-purchaser.

During this warranty period the obligation of Carson Manufacturing is limited to repairing or replacing, as Carson Manufacturing may elect, any part or parts of such product which after examination by Carson Manufacturing is determined to be defective in material and/or workmanship.

This warranty does not cover labor charges for removal or re-installation of the product. Fuses and lamps are not covered under this warranty.

This warranty does not extend to any unit that has been subjected to abuse, misuse, improper installation or which has not been adequately maintained, nor to units which have problems related to service or modification at any facility other than the manufacturer.

THERE ARE NO OTHER WARRANTIES, EXPRESSED OR IMPLIED, INCLUDING BUT NOT LIMITED TO, ANY IMPLIED WARRANTIES OF MERCHANTABILITY OR FITNESS FOR A PARTICULAR PURPOSE. IN NO EVENT SHALL CARSON MANUFACTURING COMPANY, INC. BE LIABLE FOR ANY LOSS OF PROFITS OR ANY INDIRECT OR CONSEQUENTIAL DAMAGES ARISING OUT OF ANY SUCH DEFECT IN MATERIALS OR WORKMANSHIP.

CONTROL HEAD INSTALLATION TEMPLATE

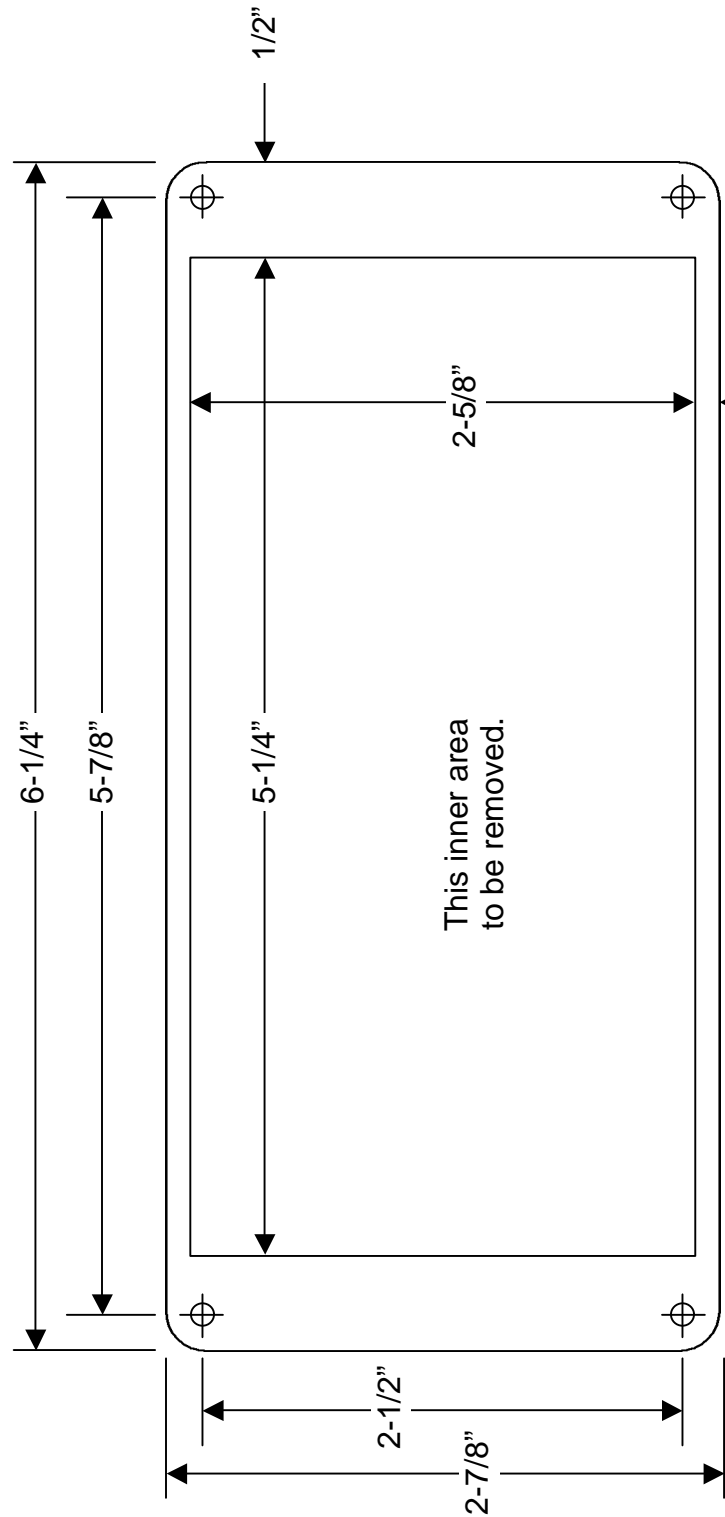

CAUTION: Please note that top and bottom edges only provide 1/8" overlap. Cut carefully.