

Important

Your motorhome makes use of many complex systems and services. Please ensure that you have read all instruction manuals carefully, and fully understand all aspects of your vehicle, before driving it on the open road.

If you have any queries on the operation of any part of your motorhome please contact your supplying dealer.



Useful Information

Model _____

Date Purchased _____

Supplying Dealer _____

Sales Person _____

Telephone Number _____

Tyre Pressure _____

Radio Code _____

Exterior Door Key Number _____

Water Filter Key Number _____

Vehicle Build Number _____



Contents

Section		Pages	
1.	Introduction	5	■
2.	Preparing For The Road	6 - 7	■
3.	External Features	8 - 9	■
4.	Driving Your Motor Home	10 -11	■
5.	On Site	12	■
6.	Gas: Services	13 -15	■
7.	Gas: Appliances	16 - 25	■
8.	Diesel Heating System	26 - 27	■
9.	Electricity: Services	28 - 38	■
10.	Integrated Entertainment System	39	■
11.	Water: Services	40	■
12.	Water: System	41 - 43	■
13.	Water: Appliances	44 - 46	■
14.	General Care	47 - 48	■
15.	Fire And Safety	49	■
16.	Security/Points Of Law	50	■
17.	Winter Laying Up	51	■
18.	Guarantee/Extended Warranty	52	■
19.	Annual Check List	53 - 56	■
20.	Good Neighbour Guide	49 - 51	■
21.	Wiring Diagram	60 - 65	■
22.	Vehicle Specifications	66	■
23.	Weights Chart	67	■



1. Introduction

Auto-Trail welcomes you to the ranks of Auto-Trail owners.

This handbook has been designed to enable you to derive the maximum benefit and enjoyment from your motor home; its information will be beneficial to experienced and new caravanners alike.

Note:

It is important that this handbook accompanies the motor home so that any future owner has the benefit of all the relevant information.

This handbook is intended to give a brief overview of your motor home and its services. You are advised to read all individual appliance instructions which will be found in the grey information wallet supplied with your vehicle.

ALL enquiries regarding your motor home should be addressed, initially, to the dealer from whom the vehicle was purchased.

Your motor home is designed to give many years of use. Regular maintenance is, however, necessary to ensure trouble free service. Your Auto-Trail dealer is equipped to offer service facilities, repair work and any parts you may require.

Always consult your Auto-Trail dealer before additional equipment is fitted to ensure the appropriate fixing support is available.

That when additional equipment is fitted the weight of that equipment and any accessories it is designed to carry will reduce the payload accordingly. Never exceed the manufacturers Gross Vehicle Weight which can be found on the plate in the engine compartment. In any correspondence, the motor home serial number should be

quoted. This can be found on the nearside plate by the entrance door.

Please note:

Every effort is made within this handbook to accurately reflect and describe our motor homes (purchased and stored on the mainland). However, our policy of continued improvements, and change in the market supply conditions means that we reserve the right to alter specifications without prior notice. Some materials used in the production of our motor homes can result in variations in the figures quoted relating to weights and measurements.

When exterior storage lockers are fitted please be aware that in certain climates moisture may enter these compartments.

As the interior of your vehicle is predominantly wood, there may be some expansion under certain climatic conditions.

Your supplying dealer is responsible for all aspects of customer care. As all vehicles are supplied with a comprehensive warranty, please ensure the dealer has fully explained all aspects of your motor home's operational systems and the necessary servicing requirements. Should you require assistance your supplying dealer is fully conversant with the correct procedures.

Modifications to your vehicle

Please check with your supplying dealer before carrying out any modifications to your vehicle. Any unauthorised modifications carried out by a third party could effect the terms of your warranty agreement. **If in doubt ask.**

So not to invalidate your warranty, always have your vehicle serviced by your selling dealer.



2. Preparing For The Road

Pre-Load Checklist

- Ensure all articles are stowed securely. Do not store tins, bottles or heavy items in overhead lockers.
- Close and secure all lockers and cupboard doors.
- Secure all bunks.
- Close and secure all roof lights.
- Store main table in transit position.
- Ensure fridge is on 12V operation and set door lock.
- Close and latch all windows.
- Never drive with windows on night setting.
- Leave all curtains and blinds open to aid visibility.
- Ensure gas bottles are correctly positioned, secured and turned off.
- Secure battery.

Loading and Distribution of Weight in the Motor Home

- Load heavy items down near the floor mainly over or between axles.
- Load evenly right to left.
- It is recommended that the table is stored on the floor between the beds or in the transit position whilst the vehicle is in motion.
- The maximum loading payload is stated in 'Your Vehicle' at the back of this manual. To ensure this is distributed evenly the maximum capacity of each axle is indicated on the chassis plate which is located either in the engine bay or under the drivers seat.

Roof Rack (If fitted)

Please be advised that the maximum recommended weight that should be carried on a roof rack is 40kg. Please be advised that in certain climatic conditions the fibreglass roof may become slippery. Please take extreme care when walking on your vehicle roof.

Apache Roof Bars

Please note that the standard roof bars fitted to the Apache model range should not be used for load carrying. Auto-Trail recommends that an additional standard roof rack be fitted for the carrying of any loads.

Frontier Rear Under Floor Storage Compartment

Please be advised that the maximum weight that should be carried in this compartment is 30kg.

Bicycle Carrier (If Fitted)

Auto-Trail recommend that if a bicycle carrier is fitted to your vehicle it should be capable of carrying no more than two cycles.

The Frontier model is designed to use a specially designed cycle carrier. Details of this are available through your Supplying Dealer.

Never Exceed The Maximum Authorised Weight Specified On The Carrier.

Auto-Trail



Apache 700 shown with roof bars

2. Preparing For The Road

Tow Bars

Various suppliers manufacture tow bars that can be fitted to your Auto-Trail vehicle. Please check with your tow bar supplier that the carrier that you fit to your vehicle meets your requirements, and does not contravene any road traffic regulations.

Final Checklist

- Secure all loose items.
- Close all interior doors.
- Place tip up sink in open position.
- Ensure that seat swivels (if fitted) are locked in the forward facing position.
- Turn off all gas appliances, except those heating appliances designed to function while the vehicle is in motion.

Stability

All models manufactured by Auto-Trail are of well-balanced design the most common causes of poor stability include:

- Incorrect tyre pressure.
- Poor weight distribution.

Tyre Pressures

Always adhere to the tyre pressures as stated in the chassis manufacturer's handbook. Always inflate to a fully laden condition.

Base Vehicle

Please make reference to the base vehicle handbook for matters relevant to the motor caravan as a road vehicle.

3. External Features

- A Exterior door retaining catch when open
- B Folding step
- C Fridge vents
- D Awning light (where fitted)
- E Status T.V. aerial (omni directional, where fitted)
- F Front marker lights

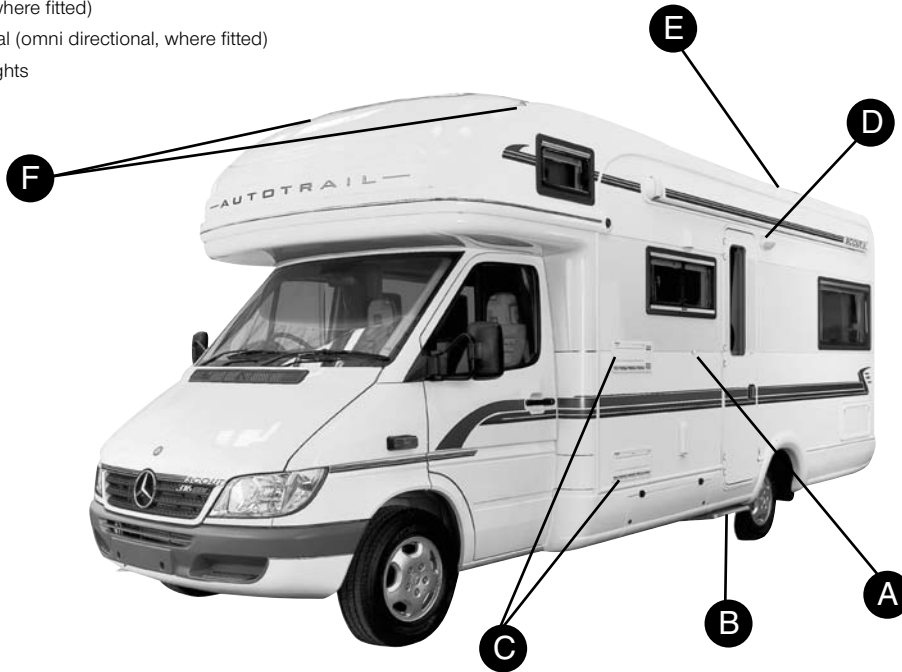

3. External Features

- A Spare wheel and battery access panel
- B External ladder
- C Lockable external access door to toilet waste tank
- D Lockable gas cylinder compartment (operated via an internal remote lever on Cheyenne and Frontier models)
- E High level brake light (where fitted)
- F Lockable fresh water filler

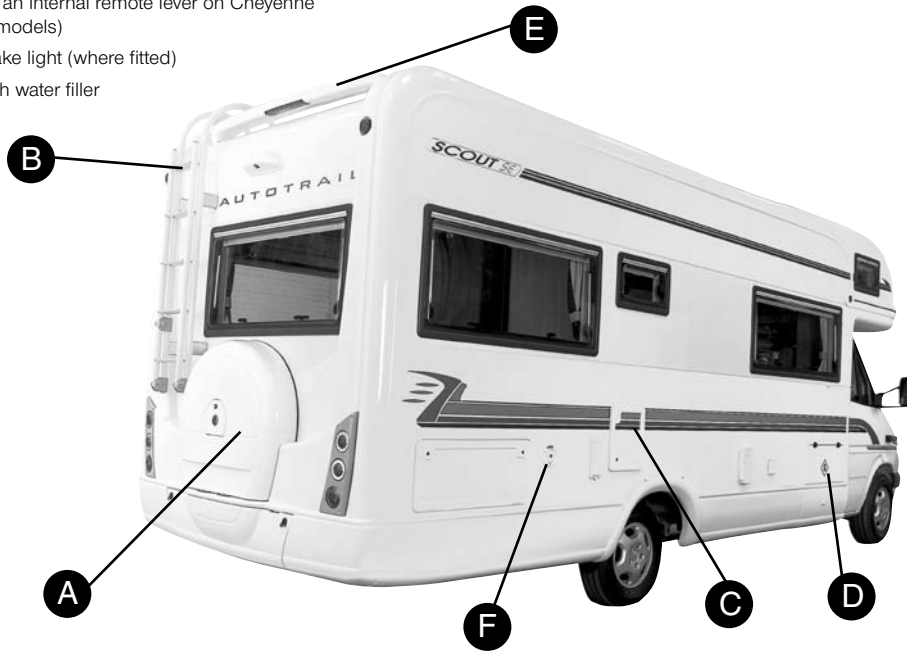

4. Driving Your Motorhome

Speed Limits

Always adhere to the speed limits.

Driving Abroad

Please ensure that you are familiar with the relevant laws and regulations that apply in the countries in which you choose to travel. Different Mainland European countries have different laws and regulations and it is your responsibility to ensure that your vehicle complies with these regulations and that you drive within the law.

Pulling Off

- Operate the clutch smoothly.
- Change gears smoothly.
- Try not to jerk the clutch.

Motor Home Handling

- Allow for motor home being wider than a car.
- Do not bump the kerb with motor home wheels.
- When passing other vehicles allow more clearance than in normal driving.
- Allow longer to speed up when overtaking.
- Allow for vehicle being longer than a car.
- Do not swing out suddenly.
- Carry out all manoeuvres as smoothly as possible.
- Use nearside wing mirror to check motor home has cleared when overtaking.

Reversing

Proficiency at reversing can only be achieved with practice and should first be attempted in a large open area. Courses are run by many organisations.

Reversing Sensor

Your vehicle may be fitted with either a visual or audible reversing aid. These aids are designed to assist drivers attention only during reversing of the vehicle, they are not intended to replace a drivers self judgement.

Auto-Trail will not accept any responsibility for any accident caused by a drivers negligence.

Please note

If a bicycle carrier or tow ball is fitted to your vehicle it could effect the operation of the reversing sensor.

Driving

Reduce speed when:

1. In high or cross winds.
2. Going downhill.
3. In poor visibility.

High-speed vehicles cause air buffeting, extra care must be taken when passing or being passed. As much space as possible should be given.



Auto-trail fitted Reversing Camera

4. Driving Your Motorhome

Changing a Wheel

- Remove wheel trims. Use the wheel brace to slacken off wheel nuts on the wheel to be changed.
- Position the jack under the axle or at the appropriate jacking point.
- Jack up motor home until the wheel for removal is just off the ground.
- Remove wheel nuts and wheel.
- Fit the spare wheel (located in the carrier) and reverse the above procedure.
- Tighten all nuts equally.

Note:

Never, under any circumstances, use the corner steadies to jack up the motor home. Instead, use a bottle jack, scissor or air jack under the axle tube as near as possible to the main chassis member.

Alloy Wheels

It is vitally important that when you get replacement tyres fitted to your vehicle the valves that are used are capable of withstanding the high pressures associated with motorhome tyres. Usually only 'bolt through' steel type valves can withstand the pressures associated with motorhome tyres.

Your vehicle may be fitted with alloy road wheels but a steel spare wheel. Please note that the steel spare wheel will require different wheel nuts (supplied with vehicle) to the ones used to fit the alloy wheels, these cannot be interchanged.

Note: Check and observe site regulations.



Alloy Wheel with New tyre

5. On Site

Selecting a Pitch

Do not pitch in a position in which your vehicle will obstruct others coming in.

Try to choose an area that is dry, reasonably level and, preferably, with a hard base.

If you have no alternative but to pitch on a slope, ensure that when you leave, you are driving down the slope.

It is always good practice to check the wheels of the motor home when parked on a slope or a slippery surface although the brakes are applied.

In poor site conditions:

1. Keep engine revs low; start in second gear if possible to prevent the wheels digging in.
2. Steer as straight as possible.

Levelling The Motor Home

Levelling must be carried out in both directions in order for the refrigerator and other equipment to function correctly.

Lower the corner steadies, using the special Auto-Trail brace, until they are in firm contact with the ground.

DO NOT use the corner steadies as a jack; they are only a means of stabilising the motor home.

Levelling pads or boards should be used under steadies and wheels where the ground is soft or uneven.

Check whether the motor home is level both front and rear.

In extreme cases where it is necessary to raise a wheel off the ground for levelling purposes, further support should be applied so that the corner steadies do not take any undue strain.

6. Gas: Services

GENERAL INFORMATION

There are four gas appliances in the motor home: refrigerator, water heater, hob and oven. Gas flows to a set of safety shut-off valves controlling each appliance. The valves allow isolation of a single appliance without affecting the operation of the other equipment.

Each appliance is fitted with a FLAME FAILURE DEVICE it is necessary to keep the gas control knob (appliances other than the water heater) depressed for 15 to 30 seconds after ignition to activate the device.

If the gas stops flowing to the appliance or the flame is extinguished, the flame failure device automatically closes the valve to shut off gas supply to the appliance.

Each appliance has a gas isolation valve fitted into the gas system to enable each appliance to be turned off from the gas supply for routine servicing or if a fault should develop. Please familiarise yourself with the location of these isolation valves which are clearly marked with their open and closed position, and which appliance each individual valve operates.

Please make sure all gas appliances are working efficiently to the recommendations of the appliance manufacturer.

TYPES OF GAS

Butane

Butane is supplied in the UK in green or blue bottles. Continental bottles usually have a male left hand thread similar but not identical to UK butane.

Butane has a recommended service temperature of down to 2°C but will work below that.

Propane

Propane is supplied in red or partly red bottles that have a female left hand thread connector. Germany and Austria supply propane with a male connection.

Propane is suitable for use at temperatures as low as -30°C and is therefore ideal for all winter caravanning.

Cylinder Compartment

Your vehicle is designed to take either a 13kg or 7kg gas bottles, this is dependant on the model you have chosen. The compartment has low level ventilation to ensure the safe operation of the cylinders and should not be blocked or obstructed in any way.

Please ensure that any additional items stored in this compartment are secure and cannot damage any of the pipe work or fittings.

Changing a Gas Cylinder

Ensure the cylinder valve is fully closed before disconnecting the high pressure hose from the bottle.

Release the gas bottle retaining straps that restrain the gas bottles into the compartment.

Carefully remove the gas bottles from the compartment taking care not to damage any pipe work or fittings in the process.

Refitting a gas bottle is a reversal of the above procedure, but please ensure that the high pressure hose is connected correctly before opening the cylinder valve.



Gas Cylinder

6. Gas: Services

Pressure Regulating Device

Your vehicle is fitted with a bulkhead mounted pressure regulating device that will provide a working gas pressure of 30 mbar (1.5 kg of gas per hour). All appliances installed by Auto-Trail are designed to work within this pressure range. Please ensure that any additional appliances not fitted by Auto-Trail are capable of working within this pressure.

Gas Hoses

Your supplying dealer will advise on the correct type of high pressure hose to connect your gas cylinder to the pressure regulator. This will depend on the type of gas cylinders you choose to carry in your vehicle.

The tightness of flexible gas hose, joints and connections must be checked regularly.

Hoses should be routinely replaced at intervals not exceeding 5 years or as recommended in the manufacturers instructions. Any hose that shows signs of splitting, wear or damage should be replaced irrespective of age.

The gas hose supplied by your dealer should not be extended in any way. Gas bottles should not be stored outside your vehicle

GAS SAFETY ADVICE

Facts About LPG

There is a danger if all air and oxygen is excluded.

LPG has been given a smell by the manufacturers to aid in the identification of leaks.

Awning Space LPG Appliance Exhaust

No danger is caused if the LPG exhaust from the refrigerator vents into an enclosed awning. If totally enclosed, space heaters may produce enough exhaust to pollute an enclosed awning to discomfort levels. In extreme cases, carbon dioxide build up could reach a dangerous level.

Motor home owners are advised to allow some ventilation when such appliances are in use.

Precautions

If a leak is suspected:

- Turn off the gas supply from the cylinder using the isolation valve situated on the top of the gas bottle.
- Never search using a match.
- Always use soap solution, or its equivalent, when testing connections.
- Do not operate any electrical apparatus, especially light switches.
- If leak is not obvious, the caravan should be evacuated and qualified personnel consulted.
- Remember that gas is heavier than air therefore sinks to the lowest point.
- Avoid naked lights when connecting or changing a cylinder.
- Check the flexible hose frequently.
- Keep bottled gas containers outside and protect against frost. If storage inside is the only option then keep away from heat sources.



6. Gas: Services

Ventilation

Low-level ventilations is provided from either the passenger and drivers door, or behind the drivers seat. High-level ventilation is provided by sky lights located in the roof of the vehicle.

All ventilation complies with European Standards and vents should not be obstructed in any way as this could lead to insufficient fresh air. If this occurs, the confined atmosphere becomes deficient in oxygen which leads to the formation of the highly poisonous gas carbon monoxide (CO). CO is odourless, colourless and tasteless and will rapidly cause unconsciousness followed by death.

If this happens there is little or no warning prior to collapse.

Note: There is no danger providing the ventilation is not blocked and any meshes are cleaned regularly.

Roof Mounted Flue Installations

All flue installations should be inspected for corrosion once a year throughout their length. If any sign of perforation is detected, the flue should be replaced. Ensure that the replacement flue is of an correct type and that it is installed by an approved engineer.

Combustible Materials

Care should be taken when storing any combustible materials near any heat source (eg space heater).

Warning

Please note that internal outlet sockets should only be used with dedicated appliances.

Please note that no appliance should be used outside the motorhome if connected to an internal socket.

Portable Heaters

Never use portable cooking or heating equipment, other than radiant heaters that are not of the direct radiant type, as it is a fire and asphyxiation hazard.

Under no circumstances should a cooking appliance be used for heating the vehicle.

7. Gas: Appliances

COOKING APPLIANCES

Your vehicle is fitted with either a Spinflo four gas burner and oven, or three gas burners and one 230V mains hot plate and oven.

The gas burners are adjustable between simmer and full flame, and the oven temperature ranges from 130°C to 240°C. The electric hot plate has six temperature settings.

Both appliances are suitable for LPG gas only and no other types of gas should be used:

User Instructions

Ensure the gas cylinder is turned on. In event of a gas smell, turn off at the cylinder and contact supplier.

Operation: Gas

Select required burner; depress the control knob and light with either a match or the ignition system if provided. When the burner has lit keep the knob depressed for a minimum of 15 seconds to ensure that the flame is established and the flame failure device is activated.

If the flame goes out when the knob is released, the procedure should be repeated holding the knob in for slightly longer. To turn off the burner turn the knob clockwise until the dot on the knob lines up with the dot on the control panel.

Warning when attempting to light the oven, the ignition device must not be operated for more than 15 seconds. If after this time the burner has not lit, stop operating the device, open the oven door and wait at least a minute before attempting further ignition of the burner.

If a burner accidentally extinguished, turn off control and do not attempt to re-light for at least one minute.

Hotplate

Pans with a diameter of up to 22cm are suitable for use on this appliance. The pans must not overhang the pan support.

Grill

When using the grill, the grill pan must always be positioned directly beneath the gas burner and the door must be open. The glass lid must be in the raised position while grilling. During preheat, if required, the grill pan should be left in position to protect the base lining.

Caution: Accessible parts may become hot while grill is in use. Young children should be kept away.

Oven: Cooking Hints

- Remove all accessories and packing from the oven and clean the interior using soap and water prior to first use.
- Place the oven shelf in the required position and close the door. Set control knob to gas mark 5 and heat the oven for approximately 20 minutes to eliminate any residual factory lubricants that may cause unpleasant smells during cooking.
- Meat must be fully thawed before cooking.
- Chilled and frozen pre-cooked foods should be thoroughly heated and attention should be paid to the manufacturer's instructions.
- To achieve best results preheat the oven at the correct temperature for 10 minutes (Belling) or 20 minutes (Spinflo) prior to use.
- When roasting with aluminium foil care must be taken that the foil does not impair circulation or block the oven flue outlet.

Auto  **Trail**



Multi-Fuel cooker with Grill and Oven

7. Gas: Appliances

- The oven shelf is designed to allow good circulation at the rear of the oven and are fitted with a raised bar to prevent trays or dishes making contact with the back of the oven. To remove the shelf, pull forward until it stops, raise the front and remove.
- The baking tray and roasting dish provided are the largest that should be used in the oven as larger items may affect the circulation and heat distribution.

The cookers are fitted with a thermostat that gives controlled temperatures throughout the cooking range. The gas mark relates to the temperature at the centre of the oven, with higher temperatures towards the top and lower temperatures towards the bottom.

This variation is approximately equivalent to one gas mark.

These zones can be used to cook, simultaneously, foods that require different heat settings.

Cleaning

DO NOT USE ABRASIVE

CLEANERS OR POLISHES.

Your new oven will keep its good looks and work efficiently if the following cleaning instructions are followed.

Painted parts: Use only a soft cloth with warm soapy water.

Vitreous metal: Inside the oven, grill compartment and hotplate only. Use a cleaner recommended for vitreous enamel or a soap filled pad, i.e. 'Brillo'.

Note: the oven and grill doors and the cooker trims are painted and must only be cleaned with warm soapy water.

Chrome parts: Use warm soapy water or a brillo pad.

Glass: Use warm soapy water or a mild cream cleaner.

Extractor Hood (If fitted)

This is located above the hob, operation is as follows: Switch 1 works the light and switch 2 the fan.

Leaks

If a smell of gas becomes apparent, turn off supply at cylinder immediately.

Extinguish all naked lights including cigarettes and pipes. Do not operate electrical switches. All doors and windows should be opened to disperse any gas build up.

As butane and propane are heavier than air, the gas will collect at low level. The strong unpleasant smell will allow the general area of the leak to be ascertained, check it does not originate from an unlit appliance. Never check for leaks with a naked flame; investigation should be carried out using a leak detector soapy solution.

Maintenance

Little maintenance is necessary for this appliance other than cleaning. This appliance must not be modified or adjusted unless authorised and carried out by the manufacturer or their representative. No parts other than those supplied by the manufacturer should be used on this appliance.

7. Gas: Appliances

Refrigerator

DOMESTIC RM7361 see side panel for description

Note:The refrigerator is equipped to operate on mains power, DC or liquid gas (propane / butane).The desired power option is selected by means of energy selector switch (A). Energy selector switch (A) has four settings:AC mains power, DC (12V), Gas (liquid gas), OFF.

Electrical Operation (12V)

The refrigerator should only be used whilst the engine is running, otherwise the on-board-battery would be discharged within a few hours.

- 1 Set the energy selector switch (A) to 12V.
- 2 Operating display "C", 12V lights "green", the appliance is now operating.
- 3 Use rotary switch (B) to regulate the temperature in the main refrigerator compartment. If the operating display fails to light up the device is not operating.

Mains Operation (230V)

This option should only be selected where the supply voltage is 230V, any different values may result in damage to the appliance.

- 1 Set energy selector switch (A) to 230V.
- 2 Operating display "C", 230V lights green, the appliance is now operating.
- 3 Use rotary switch (B) to regulate the temperature in the main refrigerator compartment. If the operating display fails to light up the device is not operating.

Gas Operation

- 1 Open the valve of the gas cylinder.
- 2 Open the shut-off valve on the gas supply.
- 3 Set energy selector switch (A) to gas.
- 4 Set the rotary switch (B) to "MAX" position.
- 5 Use rotary switch (B) to regulate the temperature in the main refrigerator compartment.

The ignition process is activated automatically, accompanied by a ticking sound for approximately 30 seconds. On successful ignition, the display LED (C) "GAS" lights yellow.The refrigerator is now functioning.

In the event of a gas fault (eg gas cylinder empty), the operating display (C) flashes yellow.

Switching the refrigerator off

Turn energy selector (A) to "OFF" position.The refrigerator is now switched off.

Important: If you are leaving your vehicle for an extended length of time (eg greater than two weeks) the energy selector (A) should be turned to the "OFF" position. Failure to do this could result in a fully discharged leisure battery which could cause long term damage to the vehicle.



Refrigerator
DOMESTIC RM7361
Energy Selection

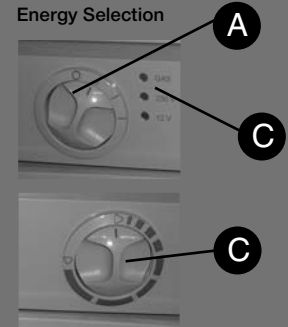

- A = Energy selection switch
- B = Gas / electric thermostat AC / DC
- C = Operating displays

7. Gas: Appliances

Theftord N150 Fridge Freezer Instructions

Switching on the refrigerator

1. Open the valve of the gas bottle
2. Open the taps of the gas supply
3. Press main switch (A). The function LED will turn blue and all symbols on the LCD display will light up.
4. Use the mode selector switch to select the "Auto" function, or one of the power sources that you want. The LCD display will show you the option you have selected.
5. Set the desired refrigerator cooling level by means of the cooling level selection switch (C). The LCD display will show you the cooling level setting that you have selected.

POWERING WITH ELECTRICITY

Auto Mode

Mains voltage (230V)

This energy source will be selected if the mains voltage is greater than 200V. This power supply requires a continuous current of 12V to operate the electronic control system.

Direct Current (12V)

The SES system will select 12V powering only if a mains voltage (230V) is unavailable, the vehicle engine is running and a voltage higher than 11V is available. If a fault occurs during electrical powering (230V or 12V), an error message will not be shown on the display as long as another energy source is available. The system will automatically switch to the available energy source that has the highest priority.

Selecting Manually

Mains voltage (230V)

The LED on the main switch warns you whenever insufficient voltage is available or if a fault occurs. If this happens, the LED will change from green to red and flash once per second and an error code is shown on the LCD display. When sufficient current is available again, or the fault has been resolved, the main switch LED will emit a steady green light.

Direct current (12V)

The main switch LED warns you whenever your vehicle's engine is not running, or if a fault occurs, or in insufficient voltage is available. If this happens, the LED will change from green to red and flash once per second and an error code is shown on the LCD display. Once the engine is running, or the fault has been resolved, or sufficient voltage is available again, the main switch will again emit a steady green light.

NB if the refrigerator has been manually set to operate at 12V, it will not automatically switch to another energy source when your vehicle's engine is not running. In this case the refrigerator will stop cooling.



THEFTORD N150
Refrigerator Controls

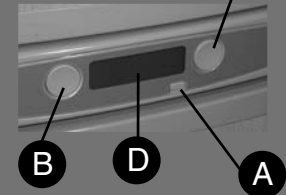

- A. Main switch ON/OFF
- B. Mode selection switch
- C. Temperature selection switch
- D. Function LED
- E. LCD Display

7. Gas: Appliances

POWERING WITH GAS

Selecting gas in auto mode

The system will operate if;

- Mains voltage is unavailable;
- The vehicles engine is not running.

Once mains voltage (230V) is available again or the vehicle's engine is running, the system will switch to the available energy source that has the highest priority of the fridge is in auto mode.

If the refrigerator switches from 12V DC to gas operation when in auto mode, the system will wait for about 15 minutes before igniting the gas. During this time however, the gas indicator light will come on. This delay is built in to avoid it switching to gas operation whenever you stop to refuel your vehicle. You can cancel the delay by immediately switching the refrigerator off and on again.

If the system selects gas operation, the ignition will be activated automatically. The gas will flow to the burner and be lit by the electric ignition. If the flame goes out, the gas will immediately be lit again.

Selecting gas operation manually

If the flame cannot be lit within 30 seconds, the gas supply will stop and gas mode will be switched off. The LED will start flashing every second and an error code is shown in the LCD display.

Gas mode can be reset only if the refrigerator is switched off. If you switch the refrigerator on again and the gas mode is still not working, the LED of the manual gas mode will flash to indicate that gas is unavailable and an error code is shown in the LCD display.

Important! It is prohibited to use gas to power the refrigerator while you are driving. If a road accident results in fire, there is a danger of explosion. It is prohibited to use gas to power the refrigerator in the vicinity of petrol stations. If it takes longer than 15 minutes to refuel your vehicle, you should switch the refrigerator off using the main switch (A).

Switching off the refrigerator

- Push the main switch (A).
- The blue LED will go out.
- The refrigerator is now completely switched off.

Travel Catch

Ensure that this is engaged whilst the vehicle is in motion.

The travel catch at the top of the door can be set in two positions. In one position, the door is held tightly shut and in the other, it is held slightly ajar so the fridge can be aired when not in use.



Thetford fridge freezer

7. Gas: Appliances

Food Storage

Always store food in closed containers. Never put hot food in the fridge, always allow at least 1.5 hours cooling first.

Never store items in the fridge that might give off flammable gases. The two star (**) frozen food compartment is designed for the storage of frozen food or for making ice. It is not suitable for freezing items.

Most kinds of frozen foods can be stored in this compartment for about 1 month. It is, however, important to read the instructions on the packet as this time may vary.

Defrosting

Frost will gradually accumulate on the refrigeration surface. This must not be allowed to grow too thick as it acts as an insulator and will adversely affect the performance. The fridge must be defrosted when the build up reaches about 3mm.

To defrost: remove ice tray and all food items from the fridge and turn off.

Warning

Normally the temperature of frozen items will rise during defrosting so should be consumed in 24 hours or discarded.

Do not try to accelerate defrosting by using a heater as this could damage the plastic surface of the fridge.

Do not attempt to scrape the ice off the surface using a sharp object. When ice has melted, wipe the fridge dry and restart it. Place food items back inside but do not attempt to make ice cubes until fridge is completely cold.

Cleaning the Refrigerator

Clean the inside of the fridge regularly to keep it fresh and hygienic. A cleaning solution of 0.5 litre of warm water and 1 teaspoon of bicarbonate of soda should be used. Cloths should be wrung out after soaking and used to clean the interior of the fridge and the fittings.

Never use detergents, scouring powder, strongly scented products or wax products to clean the interior of the fridge as they may damage the surface and leave a strong smell.

The exterior of the fridge should be wiped clean periodically with a damp cloth and a small quantity of detergent. The door gasket should only be cleaned with soap and water and thoroughly dried.

Turning off the Refrigerator

If the fridge is not to be used for some time:

- Set any switches to 0.
- Set gas valve (D) to •
- Shut off any on board valve in the gas line to the refrigerator.
- Empty the refrigerator, defrost and clean as described earlier.
- Leave the door to the fridge and the freezer compartment ajar, use the travel catch to hold in position.
- When the vehicle is to be out of use for long periods, especially during the winter, we suggest fitting the winter covers on to the vent grills.

7. Gas: Appliances

Troubleshooting

If the fridge fails to work, check the following points before calling a technician.

- Ensure that the correct procedure has been followed for starting the refrigerator.
- Check that the fridge is level.
- Ascertain whether it is possible to run the fridge on any of the energy sources.
- If the fridge fails to work using gas:
 - Make sure the gas bottle is not empty.
 - Make sure all LP gas valves are open.
- If the fridge does not work on 12V:
 - Check the 12 V supply is connected to the refrigerator.
 - Ensure that the fuse on the 12 V supply is intact.
 - Check the 12 V switch is on.
- If the fridge fails to work on 230V:
 - Check the 230V supply is connected to the fridge.
 - Make sure the fuse is intact.

If the fridge is not cold enough, it could be due to one of the following reasons:

- The ventilation is inadequate due to reduced area of the ventilation passages (partial blockages of the grilles from wire mesh etc.)
- The evaporator is frosted up.
- The temperature control setting is incorrect.
- The gas pressure is incorrect, check the pressure regulator at the gas container.
- The ambient temperature is too high.

VEHICLE HEATER

The auto heater is based on an extremely efficient heat exchanger consisting of a pair of internally and externally finned aluminium diecastings.

The gas burner is at the bottom of the vertical passage that permits complete combustion of the gas before meeting with the heat exchanger surfaces. The combustion products travel along the top horizontal section then downwards to further galleries while transferring their heat to the motorhome.

The flue outlet is at the bottom of the heat exchanger thus ensuring that the majority of the heat extracted from the combustion path is completely sealed from the living space. All the air for combustion is drawn from beneath the motorhome through the air intake and the products of combustion are discharged through a flue pipe to a roof-mounted terminal.

The heater is controlled by a knob mounted on the top of the heater case which operates a thermostatic gas valve. Ignition is by an electric re-ignition system powered by two AA size batteries and operated by a micro-switch mounted on the thermostatic gas control.

Operating Instructions

Before lighting the heater, ensure that the gas supply is turned on and that the batteries have been fitted to the ignition unit.

- Turn control knob to thermostat setting 1-10 and press it down as far as the stop. Ignition takes place automatically (Ignition sparking audible) until the flame ignites.



- a Control knob (Thermostat).
- b Integrated control switch for the TrumaVent fan TEB.
- c Pressure igniter (S3003P only).
- d Automatic ignition device with battery compartment.
- e Remote ignition display (optional).
- f Window to check flame.
- g Thermostat sensor.
- h Name plate (remove cover).

7. Gas: Appliances

- Keep the control knob pressed down for a further 10 seconds to allow the safety pilot to operate.

Attention: In the event of a fault always wait 2 minutes before attempting to re-ignite!

If the flame goes out again reignition occurs immediately during the closing time of the safety pilot (approx 30 seconds). If there is no flame the automatic igniter continues to operate until the control knob is switched to 0.

If there is air in the gas supply line, it can take up to 2 minutes until there is gas available for combustion. During this time hold the control knob down until the flame lights.

- To ensure even and rapid warm air distribution and lower surface temperatures on the heating unit, we recommend operating the heater with a Trumavent warm air system.

Room Thermostat

To maintain an average room temperature of about 22°C we recommend a thermostat setting of 3-5 with the fan off, or 4-8 with the fan on. The exact thermostat setting must be determined in each case, depending on how much heat is needed and the design of your vehicle.

Note: The thermostat probe is underneath the heater. Please note that the thermostat will be adversely affected by cold draughts from the refrigerator vents, gaps below doors etc., or by a deep pile carpet. Always be sure to avoid problems of this kind, otherwise satisfactory temperature control cannot be guaranteed.

Switching Off

Turn the control switch to 0 (the automatic ignition will switch off at the same time). If the unit is not used for a relatively long period of time, close off at the quick action gate valve on the gas pipe and the gas bottle.

Changing the batteries on the automatic ignitor

If no ignition sparking can be heard, or only at intervals of more than one second, the battery needs to be replaced. Replace the battery only if the heater is switched off. It is recommended that a new battery be inserted at the start of the heating season. Remove the heater cover, push the battery compartment cover up and change the battery. Ensure that the polarity is correct. Close the battery compartment.

Cautions

- At least one side of the under floor space of the motor home must remain open at all times so there is continual free entry of air to the under floor intake. Any build up of snow etc must be cleared from around the vehicle.
- The heater must not be used if the flue has been damaged. The products of combustion pass through the flue in the wardrobe to the flue cowl. Any damage to the flue may result in danger to the occupants.
- Avoid hanging wet clothes etc against the flue inside the wardrobe.
- Curtains must not hang within 150mm of the sides of the heater or within 300mm above the top of the outlet grille.
- Always wait two minutes before attempting to re-light the heater after switching off or after a fail-safe shut down.

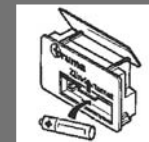

How to change the batteries on the automatic ignitor

7. Gas: Appliances

- Do not obstruct the gap at the bottom of the heater or the outlet grille slots.
- Heaters should be switched off while the vehicle is in motion.
- A guard fitted around the heater is recommended where children are present.

Note: Inspect the exhaust duct and all connections at regular intervals, and always in the event of blow back (misfire).

It is essential for the exhaust duct to be installed so that it slopes upwards over its whole length and is secured with several clamps. Never place any object on the exhaust duct, since this could result in damage. The exhaust duct connection to both the heater and the cowl must be firm and well sealed. It is no longer permissible to operate heaters with incorrectly fitted or damaged exhaust ducts!

Never allow the warm air outlet on the heater to be obstructed in any way.

For instance never hang washing on or in front of the heater to dry. Misusing your heater in this way could cause serious damage from overheating. Do not place flammable objects near the heater. Please follow these guidelines in the interest of your own safety.

TRUMATIC C 3402 / C 6002 VEHICLE HEATER

Operating Instructions

Check that any exterior flue covers are removed.

Turn on the gas cylinder and the isolation valve in the gas supply line.

Summer Operation (Hotwater Only)

Set the rotary switch (c) to summer operation 40°C or 60°C. Once the water temperature has been reached (40°C or 60°C) the burner will switch off and the yellow monitor lamp (g) will go out.

Winter Operation

Heating with hot water requirement:

Set the rotary switch (a) to the desired thermostat setting (1-9). When the system is switched on, the green monitor light (b) will light up.

Set the rotary switch to the 'operation' setting (e).

Depending on the room temperature the heater will automatically select the output of the heater required. Once the room temperature has been reached, the burner switches back to the lowest stage and heats the water content to 60°C. The yellow monitor lamp (g) indicated the heating up phase is in progress, and goes out when the appropriate water temperature has been reached.

Heating without hot water requirement:

Set the rotary switch (a) to the desired thermostat setting (1-9). When the system is switched on, the green monitor light (b) will light up.

Set the rotary switch to the 'operation' setting (d)

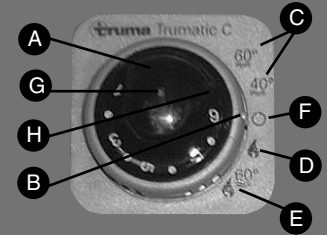

TRUMATIC C 3402 / C 6002 VEHICLE HEATER

- A - Rotary switch for room temperature
- B - Green 'operation' monitor lamp
- C - Summer operation (water temperature 40°C or 60°C)
- D - Winter operation (heating without hot water requirement)
- E - Winter operation (heating with hot water requirement)
- F - Rotary 'off' switch
- G - Yellow 'boiler heating phase' monitor lamp
- H - Red 'fault' monitor lamp

7. Gas: Appliances

Depending on the room temperature the heater will automatically select the output of the heater required. Once the room temperature has been reached, the heating will switch off (regardless of the water temperature).

If the boiler is full of water then it will be heated automatically at the same time. The water temperature is however dependent on the set output of the heater and will switch off when the room reaches the desired temperature.

In this condition the yellow monitor lamp (g) will only light up if the water temperature is below 5 °C.

Switching Off

(Gas Operation)

Switch the heating system off at the rotary switch (f).

If the appliance is not to be used for long periods, close the isolation valve in the gas supply line and turn off the gas cylinder.

Red Indicator 'Failure'

In event of a fault the red monitor lamp (h) will light up. Reset the system by switching the heater.

230V Electrical Operation (Hot water only)

When the rocker switch is in the 'on' position (j) the switch will illuminate to show that the water heater is operating. The water temperature is automatically regulated to 60°C.

Truma Ultraheat

When your vehicle is fitted with Ultraheat, you will find a separate wall switch with 500W, 1000W and 2000W settings.

Switching on

- Check that you have a mains supply, and that the fuse spur is switched on.
- Turn control ring (b) to required power setting.
- Set rotary control knob (c) to desired room temperature.

The Ultraheat can either be used as an independent heater or can be used in conjunction with the gas system to give a maximum 5.2kW output.

For night time use it is recommended that the Ultraheat system is switched to the 500W setting.



230V Electrical Operation (Hotwater Only)



j Rocker switch 'on'
k Rocker switch 'off'

Truma Ultraheat



- A - Slide switch: OFF
- B - Rotary switch: ON
Power settings:
500-1000 - 2000W
- C - Rotary control knob for room temperature (illuminated by green indicator lamp "operation")

8. Diesel Heating System

Eberspacher Cobitronic Heater

This is a diesel fuelled combination heating system incorporating the latest technology to provide hot water and air heating from the unit located under the vehicle. Diesel is drawn from the vehicles own fuel tank, with the option to combine and utilise mains voltage when available.



On / Off Button

This button is used to turn the unit on and off. The button must be pressed for approximately 2 seconds to operate. This is to stop accidental operation whilst using the heating system.



Up / Down Buttons

These buttons are used to mainly for adjusting the temperature up and down, but in some instances they are used to select certain menu options.



Enter Button

This button is used to enter a selection. This button is generally used in the setup menus and is not needed for the day to day operation of the unit. Momentarily pressing the key will display the temperature level selected (in degrees C). Press and hold this button, whilst in a menu, to return to a previous screen.



Heating and Hot Water Button

This button is used to turn the heating on or off. An LED next to the button will indicate that the heating is on.

Note: when using the timer functions, the LED shows that the heating will come on at the programmed time. Hot water is also selected with the heating.



Water Heating Button

Pressing this button means that the heater will operate the water heating only, not the air heating system.



Economy Button

This button overrides the normal heating function and is for use when energy needs to be saved. In this mode the fan speed is reduced and the water is electrically heated at a reduced power rate to minimise (mains) current consumption.

Note: this mode only works on mains hook up. The LED next to the button illuminates when this mode is in operation.



Cobitronic Heater Control Panel

8. Diesel Heating System



Frost Setting

When activated this setting overrides the normal heater operation. A LED next to the button illuminates to show that the frost mode is activated. This setting operates the heating system at approximately 5°C, and periodically operates the water heating to prevent freezing. If the vehicle is on mains hook up then the mains heating is used. If not then the diesel system operates. The heating switches off when the cabin temperature has reached approximately 15°C.



Time Set Button

Pressing this button means that the heating will (or water heater, whichever has been selected) will operate in the timer mode. Once the timer mode has been set the LED will illuminate as confirmation.



Alarm Set Button

This button is used to set the alarm on the clock



Settings Button

Note: this button is used for the system setup and diagnostics by engineers only and should not be required in normal use.



User Menu

When this button is pressed, there are five initial options that can be selected. Display the option you wish to change on the screen using the up and down buttons and then press the enter button to change that option. Press and hold the enter button to go back one step.

9. Electricity: Services

GENERAL INFORMATION

The electric system in Auto-Trail vehicles makes good use of modern technology. It is centred on the hightech Switchmode power supply system. This 12 V DC charger has been specifically designed for use in a motor home. It is capable of charging the battery safely for long periods without overcharging. As a power supply, the charger will supply all reasonable demands placed on the system. The working of each electrical circuit must be fully understood. All electrical cable terminal connections must be regularly checked to ensure that they are secure. All electricity must be turned off before disconnecting the battery. Always use the terminals provided never crocodile connectors.

Plug sockets must be regularly checked and cleaned. Wire connections must be checked for undue tension. Check cables for wear and damage, always carry spare fuses. If in doubt, see your Auto-Trail dealer.

The wiring diagram for the vehicle is included in appendix 1. There are two electrical circuits in the vehicle. One operates on 12 V and one on mains electricity. These are outlined in the wiring diagram.

12 V System

This is fed from an 85 amp-hour leisure battery that is located in a dedicated compartment in the vehicle. This is connected to the main control panel via the fuse box. The control panel inside the vehicle indicates the condition of the battery. When the engine is running, or the vehicle is connected to a mains supply, the leisure battery is charged through the onboard charging unit.

Connecting and Disconnecting the Battery

Warning - Please ensure that all cigarettes are extinguished before working in the auxiliary battery compartment. Switch off all appliances and lamps before disconnecting the auxiliary battery.

Release the battery from its restraints in the battery compartment. Disconnect the battery from its terminals. Fitting a new battery is a reversal of the above procedure.

1. EC 200 Electronic Control System

With the use of new technology and an innovative approach to user interfacing, the EC200 Power Control System provides a complete control solution for a wide range of leisure vehicles. The microprocessor controlled digital system allows the user to control equipment and view / edit system information from a userfriendly control panel that incorporates a liquid crystal 'ALPHANUMERIC' display (not Apache range).

2. System Overview

The following diagram shows the components that make-up the EC200 system. The system basically comprises a Power Supply and control Unit (PSU2007) that houses the Mains 240v protection equipment, a 200 watt 12v charger / power supply, and power control / protection for the 12v equipment. The PSU2007 is connected to a Digital Control Panel via a data cable.

9. Electricity: Services

EC200 Electronic Control System

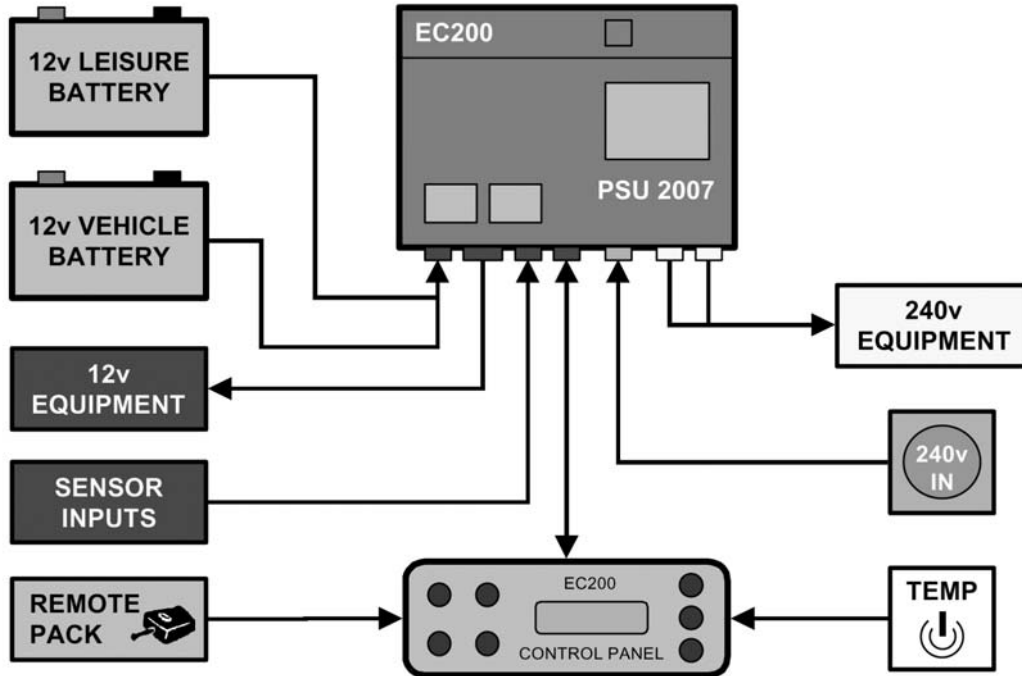

9. Electricity: Services

3. Power Supply Unit - System Operation

3.1 Introduction

For the safe operation of all electrical equipment within your Leisure Vehicle it is important that you read and fully understand these instructions. If you are unsure of any point please contact your dealer / distributor for advice before use.

Warning: Under heavy loads the PSU case will become hot. ALWAYS ensure the ventilation slots have a clear flow of air. Do not place combustible materials against / adjacent to the PSU.

3.2 Mains Connection

For your safety it is IMPORTANT that you follow these connections instructions each time your Leisure Vehicle is connected to a mains supply.

- **Ensure suitability of the Mains Supply.**

Your Leisure Vehicle should only be connected to an approved supply that meets the requirements of BS7671. In most cases the site warden will hold information regarding suitability of supply. If using a generator you also need to comply with the requirements / instructions supplied with the generator.

- **Switch the PSU internal Charger unit OFF.**

Locate the red 'Charger' power switch on the PSU and ensure the switch is in the OFF (0) position before connection to the mains supply.

- **Connect the Hook-up Lead.**

Firstly connect the supplied hook-up lead (orange cable with blue connectors) to the Leisure Vehicle and then connect to the mains supply.

- **Check Residual Current Device operation.**

Locate the RCD within the PSU and ensure the RCD is switched on (lever in up position). Press the TEST button and confirm that the RCD is turned off (lever in down position). Switch the RCD back to the on position (lever in up position). If the test button failed to operate the RCD see section 3.4.

- **Check correct Polarity.**

Locate the 'Reverse Polarity' indicator on the PSU2007 and ensure that the indicator is NOT illuminated. If the indicator is illuminated see section 3.4.

- **Check Miniature Circuit Breakers.**

Locate the MCB's within the PSU (adjacent to the RCD) and ensure they are all in the ON (up) position. If any MCB's fail to latch in the on position see section 3.4.

- **Turn the PSU ON.**

Locate the red power switch on the PSU and turn to the ON (I) position. The switch will illuminate when turned on.

- **Check operation of equipment.**

It is now safe to check the operation of the 12v and 240v equipment.

3.3 Battery Type / Selection

For optimum performance and safety it is essential that only a proprietary brand LEISURE battery is used with a typical capacity of 75 to 120 Ah (Ampere / hours). A normal car battery is NOT suitable. It is recommended that the leisure battery is always 'in circuit' when the system is in use. The battery feed is fitted with an inline fuse between the battery and the electrical harness, and is usually located immediately outside the battery compartment or within 500mm of the battery. The maximum rating of this fuse is 20A.



The following diagram shows the PSU2007 layout (the PSU2005 is the same layout).

9. Electricity: Services

Installation & Removal

Always disconnect the 240v mains supply and turn the PSU charger switch to the OFF (0) position before removing or installing the battery. When connecting the battery, ensure that the correct polarity is observed (black is negative [-] and red is positive [+]) and that the terminals are securely fastened. Crocodile clips must not be used.

Warning: Explosive gases may be present at the battery. Take care to prevent flames and sparks in the vicinity of the battery and do not smoke.

Servicing

Under normal circumstances it should not be necessary to remove the battery other than for routine inspection of the terminals and “topping up” of the battery fluid where applicable. Please see instructions supplied with the battery.

Note: Do not over-discharge the battery. One of the most common causes of battery failure is when the battery is discharged below the recommended level of approximately 10.5v. Discharging a battery below this figure can cause permanent damage to one or more of the cells within the battery. Certain electrical appliances (eg L.C.D. television monitors) are more susceptible to voltage variations than others, and may not function correctly if the battery is low or in poor condition.

Even when plugged into the mains supply, should you choose to use all 12V lighting and services simultaneously, there is the potential on certain models, in certain conditions, of consuming more 12V energy than the on board charger can replace. Whilst this is not a problem in the short term, over a longer period of time the leisure battery could become discharged.

In normal operating conditions however, the battery will be charged either overnight (when all lights are turned off), or when the vehicle is being driven (via the alternator).

9. Electricity: Services

GENERATORS

If a generator is fitted the vehicle must be regularly serviced to achieve the optimum performance. Engine speed is used to govern the output and frequency of the unit in KW and Hz, and if this is allowed to vary beyond a safe level, permanent damage could be caused to certain electronic equipment such as 12 V chargers etc.

IMPORTANT

Periodically, preferably not less than once a year, the motor home electrical installation should be inspected and tested. A report on the condition should be obtained as described in the Regulations for Electrical Installations, published by the Institute of Electrical Engineers. It is important that the main switch at the site point should be switched off, the supply flexible cable disconnected and any cover replaced on the socket outlet at the site supply point. It is dangerous to leave the supply flexible cable connected.

If a fault should develop with your electrical system that is not described in the 'fault table' and your supplying dealer cannot resolve the problem, Sargent Electrical systems operate a telephone help line that is available during normal office hours.

Tel: 01482 678981

Wiring of connecting cable and motor home mains inlet:

Pitch outlet supply



Cable plug

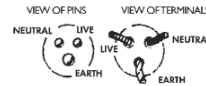

Flexible Wiring

Fixed Wiring

Brown	Live	Red
Blue	Neutral	Black
Green/ Yellow	Earth	Green/ Yellow

Cable coupler

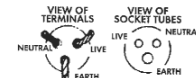

Motorhome mains inlet



The cable plug is connected to the cable coupler by a 2.5mm² flexible 3-core cable.

9. Electricity: Services

Warning:

It is essential that connections are made exactly as shown. If the terminal markings are not in accordance with the diagram, they must be ignored. If in doubt, consult a qualified electrician.

Overseas Connections

Connection to mains voltage overseas requires particular attention. Electricity supplies abroad may be of reverse polarity. The significance of this is that when an appliance is switched off, it may not be electrically isolated.

It is useful to check the polarity of the supply so that the connection can be made neutral to neutral and live to live as recommended. Your Auto-Trail, however, is fitted with a double pole circuit breaker. Check that all motor home equipment is set to accept the site supply prior to switching it on.

Note: If too many appliances are in operation at one time, the MCB may trip. This is a safety measure. On some sites, the power is not sufficient to power all items. If in doubt, consult the site manager or warden.

PSU Courtesy Light

The cupboard in which the PSU is situated is equipped with a courtesy light that is activated when the cupboard door is opened. This light is supplied by the on board leisure battery of the vehicle when stationary. Should a fault occur on this circuit and the light fail, starting the engine will reconnect the light to the vehicle battery circuit to allow fuses and Circuit Breakers to be checked etc.

10. Integrated Entertainment System



Operating Guide (built in FM modulator)

Safety Notice

It is not only illegal, but also highly dangerous for the TV / DVD monitor to be positioned where it can be viewed by the Driver when the vehicle is in motion. Please ensure you operate within the law, and more importantly, do not risk or harm the safety of yourself, your passengers and / or other road users.

General Notes

Please familiarise yourself with the individual component operating instructions (monitor, Freeview, DVD) before using this guide.

For viewing both DVD and Freeview ensure that the LCD monitor is turned ON and not in standby mode (in standby mode the LED is illuminated) by pressing the button at the bottom right hand corner.

Ensure that the vehicle is not in reverse gear as this will override all entertainment settings.

Position 3 on the selector dial (C) is not used.

On / Off switch (D) is used to isolate the entire system to eliminate battery drain when the entertainment system or reversing camera is not in use (0 = OFF, 1 = ON).

Please note this should be in the ON (1) position whilst driving.

Remote Controls

There are three remote controls required to operate the entertainment system, there are:

Small: Monitor only

Medium: Radio / DVD player

Large (silver):Freeview (must be pointed at box, not monitor)

DVD Operation

Rotate selector dial (C) to position 1 on the control tower.

Switch on DVD player using power button or remote control (see individual operating instructions).

Insert disk and press play.

Adjust volume and other settings to suit your requirements.

Freeview Operation

Note: Freeview sound requires the MD/TA button on the DVD player (bottom right hand side of fascia) to be pressed repeatedly to scroll through the various options on the player (RADIO - DVD - AUX). 'AUX' must be selected to obtain Freeview sound. If using remote control press 'MODE'.

Rotate selector dial (C) to position 2 on the control panel.

Switch on the Freeview box using switch (B) on the control tower (red light appears on freeview box).

Check that the TV booster is in the ON position.

Switch on the DVD / Radio (see individual component instructions).

Select the Auxiliary channel on the DVD player (see note above).

Turn on Freeview box using remote control (green light appears on Freeview box).

Use remote controls to change channel and adjust other settings to suit your requirements.

Note: Every time the vehicle moves into a new transmission area the Freeview box will require re-tuning to the new signal (see page 47 in Freeview operating instructions for re-tuning advice). You can also check Freeview coverage in any area by visiting www.freeview.co.uk.

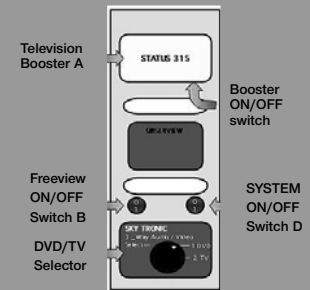

11. Water: Services

The motor home is equipped with an under-floor fresh tank, which is insulated on the Frontier range. This is filled through the filler cap sown opposite.

To fill:

- Remove the cap and insert a suitable length of pipe.
- Connect the other end to a clean water supply.
- Fill until the water level rises up the filler pipe.
- Replace the cap, lock and remove the key.
- Use only food and drug quality pipe.

The water system fitted in the motor home is kept supplied with fresh tank by a self priming and cancelling automatic pump.

This pump is fitted with a filter to ensure trouble free running. This must be cleaned periodically so there is no reduction of flow. It is unlikely that the pump will need attention between services.

However, if it does, you should contact your Auto Trail dealer who will carry out any repairs. They will also handle any regular servicing.

The pump is controlled from the electrical systems distribution panel, which is located inside the vehicle.

This pump automatically pressurises the system. When a tap is turned on, water flows from it and at the same time the pump maintains a predetermined pressure prior to shutting off.

Caution: Damage may occur if the pump is allowed to freeze or run dry.

If the water pump runs for more than 5 - 10 seconds after you have closed all the taps, it is possible that there is a leak in the system. This should be checked.

If you are experiencing problems contact your Auto-Trail dealer who will be glad to assist.

Note: Always switch the pump off at the control panel when leaving the vehicle.



Example of fresh Water top up access

13. Water: Appliances

TRUMA-ULTRASTORE

This is a 10 l capacity liquid gas storage heater.

Always read the manufacturers operating instructions prior to starting this appliance for the first time and observe the 'important operating notes'.

Filling the Truma-Ultrastore with water

- Check that the safety/drain valve in the cold water intake is closed: lever should be in the horizontal, position (e). see drawing opposite
- Open hot tap in bathroom or kitchen, with pre-selecting mixing taps or single-lever fittings set to 'hot'.
- Switch on power to water pump (main switch or pump switch).
- Leave tap open to let air escape while the water heater is filling. The heater is full when water flows out of the tap.
- Residues of frozen water can prevent filling if there is a frost. The water heater can be defrosted by switching on the heater for a short period of time (max. two minutes). Frozen pipes can be defrosted by heating the room.
- Remove cowl cover.
- Open gas cylinder and quick acting valve in gas supply line.
- Select required water temperature at rotary knob (c) infinitely variable from approx 30°C to 70°C.
- Switch on water heater at the rotary switch (a) on the control panel. Green 'operation' light will illuminate.
- If there is air in the gas supply line, it may take up to a minute before the gas is available for combustion. If the appliance switches to 'Failure' during this period, switch off

the appliance wait 5 minutes - then switch on again.

THETFORD CASSETTE TOILET

There are two varieties of cassette toilets fitted into the Auto-Trail range of motor homes, one is swivel based the other is fixed and comes with an integral toilet roll holder. They are both constructed from high quality plastics with a high gloss finish for durability and easy cleaning. The toilet unit consists of two parts, a permanently installed toilet system and a slide out waste tank or cassette.

The toilet section of the fixed toilet includes; a seat and cover, flush and valve blade opener knob, toilet tissue compartment and holder, waste level indicator, built in fluid storage compartment, a drip tray, a drain tube assembly and a fresh water tank.

The toilet section of the swivel toilet includes; a removable seat, a rotatable bowl, a control unit with flush button and a waste level warning device. The valve blade handle is located under the toilet bowl. The cassette section is the same in both varieties of toilet and is located underneath. It is removed for emptying through an access panel in the outer wall of the vehicle. A rotating pour-out spout, automatic holding tank vent, air release valve, valve blade, carrying handles and hand grips are incorporated into the cassette. For both of these models, it is essential to read the manufacturers instructions prior to use.

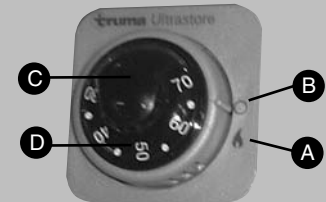

Gas Operation

- A - Rotary switch: ON - Gas Operation
- B - Rotary switch: OFF
- C - Rotary knob for temperature selection (illuminated by green light 'operation').
- D - Red indicator lamp 'FAILURE'

13. Water: Appliances

Preparing for Use

- Open access door on the side of the vehicle and swing out fresh water fill funnel (if applicable).
- Fill fresh water tank (if applicable) using a hose or a watering can until the water level reaches the neck. The tank capacity is 15 litres. Aqua rinse may be added to the water to improve bowl cleaning.
- Replace cap and swing water fill funnel back until it touches the water tank. Note: 150ml of water will remain in the fill bottle when tank is empty.
- Add Aqua Kem to the cassette to control odours. Depress retaining clip.
- Remove cassette by pulling straight out, when the cassette hits the stop tilt downward slightly and remove. This stop is for safety when the cassette is full.
- Position the tank vertically and swivel the pour-out spout upwards.
- Remove the cap Add 100 ml of the Aqua Kem Bio through the spout. Add a small amount of water to cover the tank bottom.
- Replace the cap and return the pour out spout to its original position.
- Slide the cassette, spout outwards, through the access door. Never force insertion or removal of the cassette tank as this may cause damage.
- Make sure the cassette is secured by the retaining clip. Close and lock the access door.

Note: As an alternative, deodorant may be added through the valve blade opening. Hotter weather may require additional Aqua Kem.

Caution:

- Do not add Aqua Kem concentrate or Aqua Kem Bio directly into the toilet bowl while the cassette tank valve blade is closed.
- Pressure due to heat or altitude change can build up in the cassette tank causing the contents to splash upward on opening of the valve blade if opened too fast. Open and close the valve prior to use to vent the tank.

Flushing (Electric)

- To avoid staining, before using the toilet it is advisable to add some water to the bowl by pressing down the flush knob. The water will stop flowing when the knob is released.
- To flush after use, push the flush knob down while turning in an anticlockwise direction. The turning motion opens the valve blade.
- This procedure results in the best flush and the most efficient use of water.
- After flushing turn the knob in a clockwise direction to close the valve. The toilet can also be used with the valve blade open. This allows the waste to go directly into the tank.

Toilet Tissue (Fixed Toilet Only)

- Toilet tissue is stored in a specially designed storage compartment that keeps it clean and dry.
- To replace the roll, remove the holder from the compartment by pulling up on the tissue cover.
- Hold the bottom of the holder in one hand and the cover in the other and turn in opposite directions until a click is heard.



Typical Auto-Trail bathroom

13. Water: Appliances

- Pull apart and change roll.
- Insert the prongs of the cover into the holder and, whilst holding the bottom and the cover, twist in the opposite direction until locked.
- Aqua soft toilet tissue is recommended for best results

Emptying the Cassette

The cassette capacity of the tank is 20 litres and should be emptied when the indicator goes from green to full red. The gauge does not move from green to red until the tank is over half full.

Caution: Do not allow the tank to become over filled.

- Make sure the valve blade is in the closed position.
- Open the access door on the side of the vehicle, depress the retainer clip and remove the cassette.
- Carry the cassette, spout up, using the lower carrying handle, to a household toilet or a disposal point. Set cassette in a vertical position on the ground and rotate the spout upward.
- Remove spout cap. Grasp the unit by the handle nearest the spout. Place other hand on the rear grip so that the air relief valve can be depressed with thumb while emptying.
- When empty, rinse tank and valve blade with water.
- Repeat the preparing for use procedure.

Note: Only press the air release valve when the pour-out spout is pointing downwards.

Cleaning and Maintenance

No routine maintenance is required for the toilet. The use of Aqua rinse helps to clean and protect the toilet bowl, valve blade and seals during flushing. Do not use strong household cleaners or detergents with chlorine, solvents or acid contents as they will damage the seals.

Use mild soap to clean the toilet bowl, seat and cover as well as the exterior of the toilet unit and cassette. Pour out spout and vent plug can be removed. Seals should be greased with acid free Vaseline.

Wintering / Storage

To prevent freezing in cold weather, add anti freeze to the fresh water tank. Use a non-toxic (propyleneglycol) type of anti-freeze. Refer to chart on container to obtain level of protection.

Waste Water System

All waste water flows into a waste tank which is situated under the floor of the motor home. The waste tank has a sensor fitted which indicates via the control panel, when the tank is full and in need of emptying.

14. General Care

MOTOR HOME EXTERIOR

Paintwork

The exteriors of Auto-Trail Motor homes are finished with stoved enamelled aluminium. This is a very durable surface and is easy to clean due to its high gloss finish. To maintain a showroom finish, wash the caravan regularly with mild detergent, rinse off with cold water and leather off. A good quality car wax may be applied which will make washing even easier. Abrasive cleaning agents must never be used to clean the exterior of Auto-Trail motor homes. Within the first twelve months cracks and blisters may appear on the surface of the GRP components. These are cosmetic only and have no effect on the vehicles structure. These components can be repaired using the correct procedure.

Mouldings

All mouldings are anodised or powder coated aluminium and will retain their lustre for a long time if no abrasive materials are used to clean them.

Acrylic Windows

The windows in the vehicles are fully double-glazed and with care will remain sparkling and scratch free.

Care of windows:

Small scratches:

It is possible to remove small scratches using a metal polish such as 'Brasso' or a propriety acrylic polish of a suitable grade dependent on the severity of the scratches.

Cleaning:

Wash down as you would your car. Do not use a sponge on dirty windows. When all dirt has been removed, dry with a

leather or 'vyleda' type cloth. The catches and stays do not need lubricating.

Removing tar:

Use 'Jove Tar Remover' on double glazed windows. It is available from most leading car accessory or do it yourself shops such as 'Halfords'. Do not use petrol or other chemicals without approval.

Motor Home Interior

Side Walls, Roof Lining and Furniture

A simple wipe with a damp cloth and a very mild detergent is all that is necessary.

Soft Furnishings

Carpets should be vacuumed occasionally to remove grit and sand. This helps maintain good appearance and ensure long life. The upholstery can be cleaned with a mild, reputable upholstery cleaner. It is recommended that the curtains be dry cleaned.

NOTE: It may be necessary to cut the fitted carpet in some circumstances to facilitate certain repairs to your vehicle.

Upper Bunks

Care shall be taken against the risk of falling out when this bunk is used by children, especially under three years of age.

Cupboard Catches

It is advisable to lightly oil cupboard catches, sliding bolts and hinges from time to time.



Typical Auto-Trail soft furnishings

14. General Care

Vanity Unit

Your vehicle is fitted with a vanity bowl. Do not pour very hot water into it as it is made from a moulded polymer material that may deform. Always put cold water in first.

Care of Plastic Components

The cleaning of any plastic components in the vehicle, e.g. Shower tray, should only be undertaken with mild soapy water.

General household cleaning products should not be used as they may cause embrittlement and cracking of the mouldings. Auto-Trail V.R. Ltd will not be held responsible for any replacement if it suspected that this is the case.

Gold Plated Fittings

These should never be cleaned using abrasive cleaners. Clean with a damp cloth and polish with a dry cloth only.

Natural Wood Worktop Edges

Should your vehicle worktop edges show signs of the lacquer breaking down, they should be re-sealed using a proprietary yacht varnish (or equivalent).

Maintainance of Appliances

In the interest of safety, replacement parts for an appliance shall conform to the appliance manufacturers specifications and should be fitted by him or his supplying agent.

Modifications

Never allow modifications of electrical or LPG system appliances except by a qualified person.

15. Fire And Safety

FIRE AND SAFETY PRECAUTIONS

In Case of Fire:

- Get every one out of the motor home.
- Call the fire brigade.
- Turn off outside gas valve, remove cylinders from vehicle and place some distance away if possible.
- If it is an electrical fire, always turn off the supply as quickly as possible.
- Tackle the fire only if it is safe to do so.

If Tackling the Fire:

- Tackle from the outside not the inside.
- Stand back about two metres from the motor home while aiming the extinguisher at the base of the fire not the flames.
- Once the extinguisher is empty, close the vehicle door and await the fire brigade. Do not re-enter the vehicle even if the fire appears to be out, there is always a danger of re-ignition.

Cooker Fires:

- Never use an extinguisher on a flaming pan as there is a danger of explosion. Always use a fire blanket.
- If possible, try to turn off the gas flame.
- Never throw a flaming pan outside.
- Keep hands away from the flames and smother the flames.
- Pull the blanket tightly over the pan to eliminate oxygen.
- Do not throw the blanket over the fire, calmly place it over the pan paying particular attention to the handle.
- Do not remove the blanket from the pan until sure the flames are extinguished and the pan has cooled completely.

Engine Fires

Switch off the engine and get everyone away from the vehicle. Use extinguishers from outside the vehicle at a safe distance and call the fire brigade. If the fire begins to develop, leave the area at once as there is danger of explosion if the fuel tank catches fire.

Smoke Detectors

It is a legal requirement for a smoke detector to be fitted in a motorhome. Read the instructions carefully and test the detector prior to every trip.

The smoke alarm has a manual override switch to prevent unwanted operation due to fumes or steam during cooking. Use of this switch does not prevent operation if a fire occurs.

The smoke alarm is an ionisation point-type smoke detector, designed to give early warning of a developing fire and so give extra time for escape.

The alarm will be set off by even small traces of smoke and, when fitted in an appropriate way, gives a warning sound loud enough to wake people from normal sleep.

Remember that a smoke alarm cannot prevent fires or reduce the risk of a fire starting. It does not warn of dangers which may lead to fire such as gas escapes. Take sensible precautions to reduce fire risks.

Fire Extinguisher

Your vehicle should be equipped with a dry powder fire extinguisher. This will either be located near to the entrance door or behind the drivers seat. You are advised to familiarise yourself of the location and operation of the extinguisher before using your vehicle.



Fitted Fire Extinguisher in situ

16. Security/Points Of Law

SECURITY

At Auto-Trail, we have tried to go further than any other motor home manufacturer to protect your investment.

Make it difficult for the thief by protecting your motor home and its contents. Always lock all doors and windows when leaving, even for a short time. Security locks, hitch locks and wheel locks are essential.

Keep a spare key in a safe place. If a replacement is needed, as the keys are not easily cut, the dealer where the vehicle was purchased keeps a spare. Should you lose that key then Auto-Trail can supply you directly for a small fee.

Motor Home Theft

The theft of a motor home can occur in the most unlikely circumstances; from a motorway service area, even from the owners drive.

Make sure all windows and doors are secured even if only leaving the vehicle for a short time. Do not leave valuables in easily visible positions inside the vehicle.

POINTS OF LAW

The essential law for motor home owners is the Road Traffic Act (1972) and the regulations that followed.

Gas

It is strongly recommended that the fridge is run off car electric's whilst the vehicle is in motion. This is because of the potential risk of explosion and fire risk of naked flames near refuelling points. It is also recommended that all other gas appliances are turned off whilst the vehicle is in motion.

Highway

Open land up to 14 m from the highway is technically part of the highway. It is an offence to drive more than this distance onto a common and overnight parking on many commons is expressly forbidden. With the exception of motorways, parking on a roadside verge within 14 m of the road is not an offence. However, if an obstruction is caused, the police may bring prosecution.

A lay-by is part of the highway and a motor home owner stopping over night may be prosecuted for obstruction.

The above is for guidance only and is correct at the time of printing.

Always make sure you park your vehicle only where permitted.

17. Winter Laying Up

Whether you use your motor home all year round or lay it up for the winter, care should always be taken to ensure your investment is receiving the very best attention. The normal regular maintenance has been covered in the preceding pages.

The following tips will be helpful for the periods when your motor home is not regularly used. It applies if you store in a compound away from home or in your own drive.

One of the dangers is storing in one position with slightly deflated tyres. The walls are bound to suffer and present you with a risk of blowouts. This is especially true if you go to the continent and travel at faster speeds than permitted in the UK. You should turn the wheels every couple of weeks or remove them altogether. Do not jack the vehicle on its corner steadies, use a conventional car jack then lower it onto wooden blocks or axle stands.

All moving parts should be checked for free operation and lubricated accordingly. This includes corner steadies, handbrake, linkages, brakes etc. Prevention is better than cure therefore it is recommended that the complete coupling and brake drums are covered with a plastic bag and tied at the end to prevent moisture accumulating.

It is important that the water system is drained off during freezing weather when the motor home is not in use or after the last trip out of the season. Failure to do this could result in serious damage to components.

Frost damage is not covered by warranty, it is the owner's responsibility to take reasonable precautions.

To drain off:

- Open drain cock on main tank.
- Drain the heater.
- Open any drain cocks in pipe.
- Open all taps and leave open.
- Wait five minutes.
- Run pump
- Drain cassette toilet (see instructions)

Consult all water component manufacturer's handbooks.

Before starting to use your motor home after a long lay off, check all gas appliances, points and electric's.

Mains warning: Once a year (recommended) the electrical installation should be inspected and tested by a qualified electrician.

It is recommended that the upholstery is removed from the vehicle before placing your vehicle into winter storage. The curtains should also be drawn to prevent discolouration of the furniture etc.

The water system should be flushed through with sterilising fluid prior to laying up and again before the next use. It is recommended that the cupboard doors are left open to allow air to fully circulate.

If you are unfortunate enough to suffer a major accident, your dealer has the equipment and training to undertake most types of repair



18. Guarantee



1. Guarantee for First 12 Months

Auto-Trail VR Ltd hereby guarantees, subject to the following limitations and conditions, that for a period of 12 months from the date of delivery of an Auto-Trail VR Ltd Motorhome to the first purchaser, Auto-Trail VR Ltd will, through its supplying dealer network, at its option repair or exchange free of charge (including labour charges) any part of the second or third stage conversion of the vehicle (with exception of those parts listed in paragraph 2 C. which need(s) repair or replacement due to defective parts or workmanship.

In addition, the base vehicle of your Auto-Trail VR Ltd Motorhome is covered by the individual manufacturer's warranty terms and conditions, details of which are included with your information folder.

2. Limitations and Conditions

A. This guarantee is limited to the first purchaser and applies only where the vehicle is used for private use by the purchaser and excludes any use for hiring out purposes.

B. This guarantee shall not apply to any parts damaged through accident, fair wear and tear, improper use of the vehicle, if the vehicle has been altered in any way or if repairs have been attempted other than by service staff of Auto-Trail VR Ltd or its supplying dealers or other agents approved by Auto-Trail VR Ltd. Improper use includes but is not limited to overloading, neglect, use for time trials or use on unsuitable roads or surfaces.

C. This guarantee does not apply to light bulbs, tubes or globes, adjustment to door catches and locks other than routine maintenance and lubrication or paintwork generally. Without prejudice to the terms of this guarantee, complaints concerning paintwork during the first twelve months will be dealt with on their merits if notified to Auto-Trail VR Ltd immediately.

D. Subject to paragraph 3 below and except for liability for death or personal injury resulting from negligence, Auto-Trail

VR Ltd will not be liable in any manner whatsoever whether in contract, tort, misrepresentation or otherwise, for any consequential loss, damage or injury in connection with the supply of any Motorhome to or execution of work for the purchaser.

E. For work under this guarantee you should return your Motorhome to the supplying dealer from which it was purchased

F. Auto-Trail VR Ltd's agents, representatives or supplying dealers have no authority to vary the terms of this guarantee.

G. Full particulars of the serial number, date of purchase and supplying dealer from whom the vehicle was purchased must accompany any part or parts returned directly to Auto-Trail VR Ltd.

3. Statutory Rights

Nothing in this guarantee shall affect or derogate from the statutory rights of the consumer.

Note: If your vehicle is offered with extended warranty, ensure your dealer registers it at the time of collection and supplies you with a copy of the warranty policy.

Note: Auto-Trail VR Ltd will not be liable for any costs incurred by the customer as a result of taking the vehicle back to the selling dealer or manufacturer for warranty work.

AA Cover

Your new Auto-Trail VR Ltd Motorhome is covered by the AA for the first 12 months. A membership card will show a freephone breakdown assistance telephone number. In the event of a breakdown simply telephone the AA operations centre and their staff will provide assistance and explain the service provided in more detail.

19. Annual Check list

Auto-Trail Motor Home Annual Checklist.

Introduction

It makes good sense to check over your motor home at least every year. If you tend not to use it much during the winter months, check it over before storing it. Any defect, repairs or adjustments can then be made without rushing. At the start of the new season, check and clean the motor home inside and out, lubricate and top up any systems that may have been missed in the autumn and get ready to enjoy another year of fantastic holidays and weekends away.

1. Body Mounting

Body to chassis: Examine all fixings holding the body to the chassis. These may be direct connections or via sub frame. Check that all fixings are present and tight.

Body to cab: Examine the joint between the body and the cab for any signs of movement. Check that the sealing media are sound.

Body retention (de-mountables): Check that the body retaining gear is serviceable and tight. Check that the body support struts are serviceable and tight.

2. Windows

Window fitments and operation:

Check that the window glazing rubber or seal is in good condition and that there is no sign of deterioration or cracking. Check that the windows open and close easily and smoothly. On top hung windows ensure that the fixing of the top hinge rail is satisfactory. Check that there is a good weather seal when the window is closed and latched. Ensure all catches and stays operate satisfactorily. Repair or replace any defective parts.

3. External Doors

Security: Check hinges and catches for satisfactory operation and ensure that the doors are held securely shut when latched. Check that keys and internal latches lock the doors properly. Check that any device designed to hold the door in an open position is fitted correctly and operates positively.

Seals: Ensure that the door seals are in good general condition and are free from cracking and other signs of deterioration. Check that when the door is closed it provides a weather tight seal.

4. Internal Doors

Security: Check that the hinges and catches are in good condition and operate properly. Ensure that the doors are securely shut when latched.

Safety: Check that any device to hold door closed can be operated from both sides of the door to enable it to be opened in an emergency.

5. Chassis or Under-body Attachments

Corner steadies: Check that the attachments to the chassis are reliable. Make sure that the steadies work smoothly and do not wobble when in extended position. Lubricate the screws.

Folding step: Check the step pivots for satisfactory operation or signs of wear. Check that the retaining mechanisms holds the step securely when closed. If a warning light is fitted, check that the switch is working.

19. Annual Check List

Under-floor water tank mountings: Check that the mounting frames are fixed securely to the body. Check that any tank release fastenings are free from rust and corrosion and they operate smoothly. If necessary, remove rust with a wire brush, treat with a rust inhibiting solution and lubricate joints.

Spare wheel: Remove spare wheel and check for damage. Check tyre pressure. Check that the mounting is securely attached to the body. Check for satisfactory spare wheel retention.

Wheelboxes: Check for damage, corrosion, water seepage, or signs of tyre rubbing.

6. Attachments to Body Exterior

Roof lights: Check the general condition, security and that the sealing has not deteriorated.

Roofracks and ladders: Check general condition and that they are securely attached to the body. Check roof for signs of damage around the rack.

Mouldings and trims: Check the security of fixings. Check the seals have not deteriorated.

Flue terminals and air vents: Make sure that these are not blocked. Check the security of the fixings. Check the seals have not deteriorated.

7. Internal

Body seepage: Examine for signs of moisture staining in areas under windows, sides of roof and in corners which might indicate water seepage. Use a moisture meter if unsure.

Furniture: Check that all furniture is securely fixed. Make sure that the door hinges, catches and stays operate smoothly.

Dinette seat and beds: Check seat bases for signs of damage and ensure fixings are secure. Make up the beds according to the manufacturer's instructions and check for rigidity and safety.

Curtains, blinds and nets: Check that the tracks are secure and without movement. Check that the curtains draw freely without snagging. Check the operation of the blinds and/or nets. Check the fly screens in the roof lights and air vents.

Cab seats: Where cab seats form part of the living area and/or bed layout, check that they are attached securely. Make sure that the seat slides, swivels and seat backs operate smoothly and easily.

Fire extinguisher: Check the condition and the expiry date. If the date has expired or the extinguisher is partly exhausted, replace.

Warning notice: check legibility and condition.

Portable or open flame heating equipment should not be used. If you have such equipment on board, consider very carefully whether the risks are worth it.

8. Gas Systems

Cylinders and regulators: Check the compatibility of cylinders and regulators. Regulators for butane (blue) cylinders should be stamped with the pressure '11" WG (28m bar)'. Regulators for propane (red) cylinders should be stamped with '14" WG (37m bar)'. Ensure that your regulator controls the gas to the correct pressure for the type of cylinder in use. Check that the air vents and gas drain hole in the floor of the cylinder compartment are free from obstruction. Check that the seals on all the internal doors are in good condition and fit properly.

19. Annual Check List

Hosing and piping: Check flexible hoses for cracking and condition. Check the date stamped on them has not passed. If the expiry date is close or passed, have the hoses replaced. Check all rigid piping for adequate support and any damage.

Appliances: As a guide checking the gas appliances can be summarised as follows:

- **Cleaning:** where appropriate, remove cover(s) to gain access to exchanger. Remove any build up of fluff or other foreign matter. Re-assemble and test operation. Clean flame-viewing window.

Operation of controls: Check all knobs etc are secure on their spindles and that they work smoothly. Check that the appliance works properly by using normal controls without forcing. If the gas taps are stiff to operate, ease them open with an approved LPG grease.

Flame structure:

- **Pilot flames** should burn quietly and cleanly.
- **Refrigerator:**When the fridge gas control is turned to maximum the flame colour should be predominantly blue.
- **Water heater:**The main burner should burn blue and of even height.
- **Ovens:** Flames should be of even height and burn quietly.The colour should be mainly blue/green but there will be yellow tips to the flames as the burner heats up.
- **Grill burners:** Flames may develop yellow tips as they heat up, especially when using butane.
- **General comments:**A flame lifting away from the burner indicates that the pressure is too high. A yellow flame

causes sooting and indicates the pressure is too low. If these faults occur, recheck the regulator, cylinders and pipes, adjust as necessary.

- **Flues:** Check security of fixings, attachments to appliances and flue terminals. Check for damage and corrosion. Check for gas leakage into the vehicle.
- **Flame failure device (FFD):** Check for satisfactory operation by the following method: after the appliance has been checked, allow time for the thermocouple to cool. Try to relight the appliance by turning it on without pushing the gas control knob in. If the appliance does not light the FFD is working.
- **Security:** Check that all appliances are securely fixed to the vehicle/furniture and that no 'play' is present. Where applicable check that the water pipes are properly attached and there are no signs of leaks.

9. Water System

Before operating the water system, check the following items visually for signs of leakage.

Fresh water tank/container: Check condition. Fill tank and check for leaks. Check external filler and filler pipe to tank. Check venting. Check presence and condition of filler cap.

Waste water tank:

Check that the drain tap is clear and working properly. Make sure that the drain hose is present and in good condition.

19. Annual Check

Filter Pump: When applicable, remove filter, clean and replace. Check the in-line pump for security of fixing and condition. Check that the pump inlets and outlets are clear and not obstructed. Check security of fixing and condition of delivery hose and electric cable.

System check: Operate the pump and check all piping for leaks. Operate all taps and shower. If a hot water system is fitted, it can be checked for leaks using cold water. (Note: aerated water from a tap could be caused by a leak on the suction side of the pump.)

Waste water system: Allow water to run through drain pipes: check for leaks and satisfactory draining from sinks etc. Couplings and fluids: Avoid confusion by making sure proper markings are used: Blue for fresh water and red for waste water. Check that the filler positions are correctly designated: 'Petrol', 'Diesel' and 'Water' as appropriate.

10. Electrical System

Extra Low Voltage 12 V (Excluding vehicle electric's).

Batteries: Check the condition of any battery including connections, wire, fuses and relays connected with domestic electric's.

Wiring: Examine all visible wiring for damage or wear. Check that all connections are safe.

Fuses and holders: Check that all fuses and fuse holders protecting the domestic electric's are satisfactory. Check that fuse ratings are compatible with the appliances being protected.

Appliances: Inspect all appliances for signs of damage, overheating or wear. Check the security of the fixings. Test the operation of each appliance.

Mains system 240V: Inspection and certification of the 240 V system should only be carried out by a qualified electrician who is an approved Contractor of the NICEIC.

20. Good Neighbour Guide

Motor Caravaners Good Neighbour Code

At a Camp Site

On Arrival

Park as close to the reception area as possible and report your arrival. Do not drive to a pitch and park unless directed by reception staff.

Vehicle Movement Around the Site

Always keep to the site roads unless directed otherwise. Obey the speed limits, these are generally 10 mph. Note: Stopping distances on grass are greater than on a normal road. You must have a current valid driving license to drive a vehicle on site roads. Park where directed on your pitch. Where possible you should leave approximately 6m of free space around your vehicle.

Using Site Appliances

Connect all mains hook-ups correctly and carefully. Turn off all fresh water taps completely. Use facilities such as toilets and showers with care and consideration, leaving them in a tidy condition. Young children should be escorted and supervised.

Disposing of Waste

If your vehicle is not fitted with a waste water tank, place a suitable container under all waste water outlets. Do not allow these to overflow. Make sure you empty the containers at appropriate waste water points.

Empty chemical toilets only where directed. Avoid damage to sewerage treatment works by using only approved chemicals. Phenols, coal tar or caustic based fluids must never be used under any circumstances.

Solid bulky items such as disposable nappies etc must not be put into the chemical closet emptying point or site rubbish bins. Wrap them in a polythene bag and place in designated containers. Household rubbish should be put into the private rubbish collection bins.

Noise Pollution

Please show consideration by thinking how the noise you create will affect those around you. Open and close doors quietly. Control noise made by your children: do not allow them to play with kites, model aircraft, catapults or airguns close to motor caravans. Do not allow them to play loud, boisterous ballgames. Keep volume turned down on CD players, personal stereos, radios and TVs. Do not play musical instruments so loudly that they will upset your neighbours. If you have a power generator, make sure it is adequately silenced and use it with consideration especially after dark.

Pets

Most site operators do not object to well behaved pets but they should be kept well under control. No animal should be allowed to run loose on the site. Leads must be no longer than 3m. Animals are not allowed in the shower or toilet blocks. Dogs must not be allowed to foul sites, roads or green areas. Carry a small spade and a supply of plastic bags in your motor caravans in order to clean up any mess made by your dog. It is then possible to dispose of it in an appropriate manner.

20. Good Neighbour Guide

Fire Precautions

Read all fire precaution notices and make sure that you and your family are familiar with the locations of hoses, extinguishers and assembly points.

Although not compulsory, it is a good idea to carry a 2-kg dry powder fire extinguisher in your motor home. It must comply with BS5423 and be marked 'BSI' or 'FOC approved'. To comply with BS5423 it must be checked regularly. Think carefully where you will site the extinguisher and, it should be near the door but not too close to the cooking area.

A sudden flare up may prevent you from reaching it. A fire blanket is a good idea for the kitchen.

Barbecues should not be used unless permission has been given. If you are allowed to use a barbecue, use it with care and consideration for those around you. Open fires are not allowed on campsites.

Tents and Awnings

It is polite to ask permission before erecting a tent or awning. Permission will normally be granted if the tent is of a recognised standard make and in good condition.

If the stay is longer than a day or two the groundsheet and/or side flaps of the awning should be lifted to avoid unsightly patches or damage to the grass.

Leaving the Site

Always tidy your pitch and make sure you do not leave bags of rubbish lying about. Check out at reception, pay your site fees and thank them for an enjoyable stay.

Wild Camping

Camping on a non-licensed site without the permission of the landowner is illegal in the UK.

If you do have permission to camp on an unlicensed site, always follow the advice in the code.

Pay particular attention to the following points:

- Dispose of litter only in receptacles provided for the purpose. If there are none, put litter in plastic bags and take it away with you to dispose of in an appropriate manner.
- Control the water waste from your motor home, do not let it run onto the ground.
- Chemical toilets must only be emptied in an appropriate waste point.
- Do not hang washing or similar items outside your vehicle.
- Do not allow children to climb on fences or walls. Damage to these may allow farm animals to stray into the wrong field.

Parking

You should only park your vehicle in an approved place and during the permitted times. Do not use any of your facilities such as cooking or washing in a way that may cause annoyance or inconvenience to those around you.

Driving

When driving your motor home on a public highway or private, you must give consideration to all other road users and comply with the highway code.



Typical awning fully extended

20. Good Neighbour Guide

All the time your motor home is moving:

- Passengers must be wearing seatbelts.
- Elevating roofs must be lowered and correctly secured.
- Top hinged windows must be closed and secured.
- All doors and access lockers for gas containers and chemical toilets must be properly closed.
- Exterior steps must be retracted and secured.
- Gas appliances must not be used unless the manufacturer states that it is safe to do so. (Such as a Gas operated refrigerator). While refuelling or on a ferry, ALL gas systems must be turned OFF.

If you have to drive slowly for any reason and there is a build up of traffic behind you, pull over and allow other traffic to pass as soon as it is safe to do so.

User Manuals

Before using your motor home for the first time, and at the beginning of each season, read and follow the advice given by the manufacturer and appliance manufacturers in their user handbooks.

Protecting the Environment

Always behave and, encourage children to behave, in a manner that protects the environment and other people's property. Please read and follow the advice contained in the country code and the coastal code.