

ORDERING REPLACEMENT PARTS

If you encounter any difficulties or problems with this product, contact the ICON Fitness Lifestyle Ltd. office, or write:

ICON Fitness Lifestyle Ltd.
Greenwich House
223 North Street
Sheepscar
West Yorkshire
Leeds LS7 2AA

Tel: Country Code: 0345-089009
Fax: 113-241-1120

To help us assist you, please be prepared to give the following information:

1. The MODEL NUMBER of the product (WESY96450).
2. The NAME of the product (WEIDER® PRO 9645 Home Gym System).
3. The SERIAL NUMBER of the product (see the front cover of this manual).
4. The KEY NUMBER and DESCRIPTION of the part(s) (see the PART LIST and EXPLODED DRAWING attached at the centre of this manual).

PRO 9645™

USER'S MANUAL

Model No. WESY96450

Serial No. _____

Write the serial number in the space above for reference.

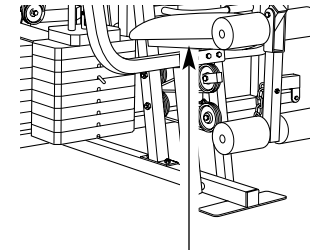

Serial Number Decal (Under Seat)

QUESTIONS?

As a manufacturer, we are committed to providing complete customer satisfaction. If you have questions, or find that there are missing or damaged parts, we will guarantee you complete satisfaction through our Customer Service Department.

Please CALL:
0345-089009

Or WRITE:
ICON Fitness Lifestyle Ltd.
Greenwich House
223 North Street
Sheepscar
West Yorkshire
Leeds LS7 2AA

CAUTION

Read all precautions and instructions in this manual before using this equipment. Save this manual for future reference.



WEIDER®

TABLE OF CONTENTS

IMPORTANT PRECAUTIONS2
 BEFORE YOU BEGIN3
 ASSEMBLY4
 HOW TO USE THE HOME GYM SYSTEM22
 WEIGHT RESISTANCE CHART24
 TROUBLE-SHOOTING AND MAINTENANCE25
 CABLE DIAGRAMS26
 ORDERING REPLACEMENT PARTSBack Cover

Note: A PART IDENTIFICATION CHART and a PART LIST/EXPLODED DRAWING are attached to the centre of this manual. Remove the PART IDENTIFICATION CHART and the PART LIST/EXPLODED DRAWING before beginning assembly.

IMPORTANT PRECAUTIONS

WARNING: To reduce the risk of serious injury, read the following important precautions before using the home gym system.

- | | |
|--|--|
| <ol style="list-style-type: none"> 1. It is the responsibility of the owner to ensure that all users of the home gym system are adequately informed of all precautions. 2. Read all instructions in this manual before using the home gym system. 3. Use the home gym system only on a level surface. Cover the floor beneath the home gym system for protection. 4. Inspect and tighten all parts often. Replace any worn parts immediately. 5. Keep small children and pets away from the home gym system at all times. 6. Never release the press arm, butterfly arms, military press arm, leg lever, leg press plate, lat bar or nylon strap when weights are raised. The weights will fall with great force. 7. Keep hands and feet away from moving parts. Always wear athletic shoes for foot protection. 8. Always stand on a foot plate when performing an exercise that could cause the home gym system to tip. 9. Keep your hands away from the leg press upright when the military press arm is being | <ol style="list-style-type: none"> 10. Keep your hands away from the assist upright when the assist arm is being used. Your hand could become pinched between the assist upright and the assist arm. 11. Always be sure that your body weight is fully supported by the dip arms or the pull-up arms before kneeling on the assist arm. The assist arm can drop quickly when your body weight is placed on it. 12. Inspect all cables before each use. Make sure that the cables remain on the pulleys at all times. If the cables bind while you are exercising, stop immediately and make sure that the cables are on all of the pulleys. Replace all cables every two years. 13. <u>Always disconnect the lat bar from the home gym system when performing an exercise that does not use the lat bar.</u> 14. If you feel pain or dizziness at any time while exercising, stop immediately and begin cooling down. |
|--|--|

WARNING: Before beginning this or any exercise program, consult your physician. This is especially important for persons over the age of 35 or persons with pre-existing health problems. Read all instructions before using. ICON assumes no responsibility for personal injury or property damage sustained by or through the use of this product.

Military Press Cable (72) and Leg Press Cable (99)

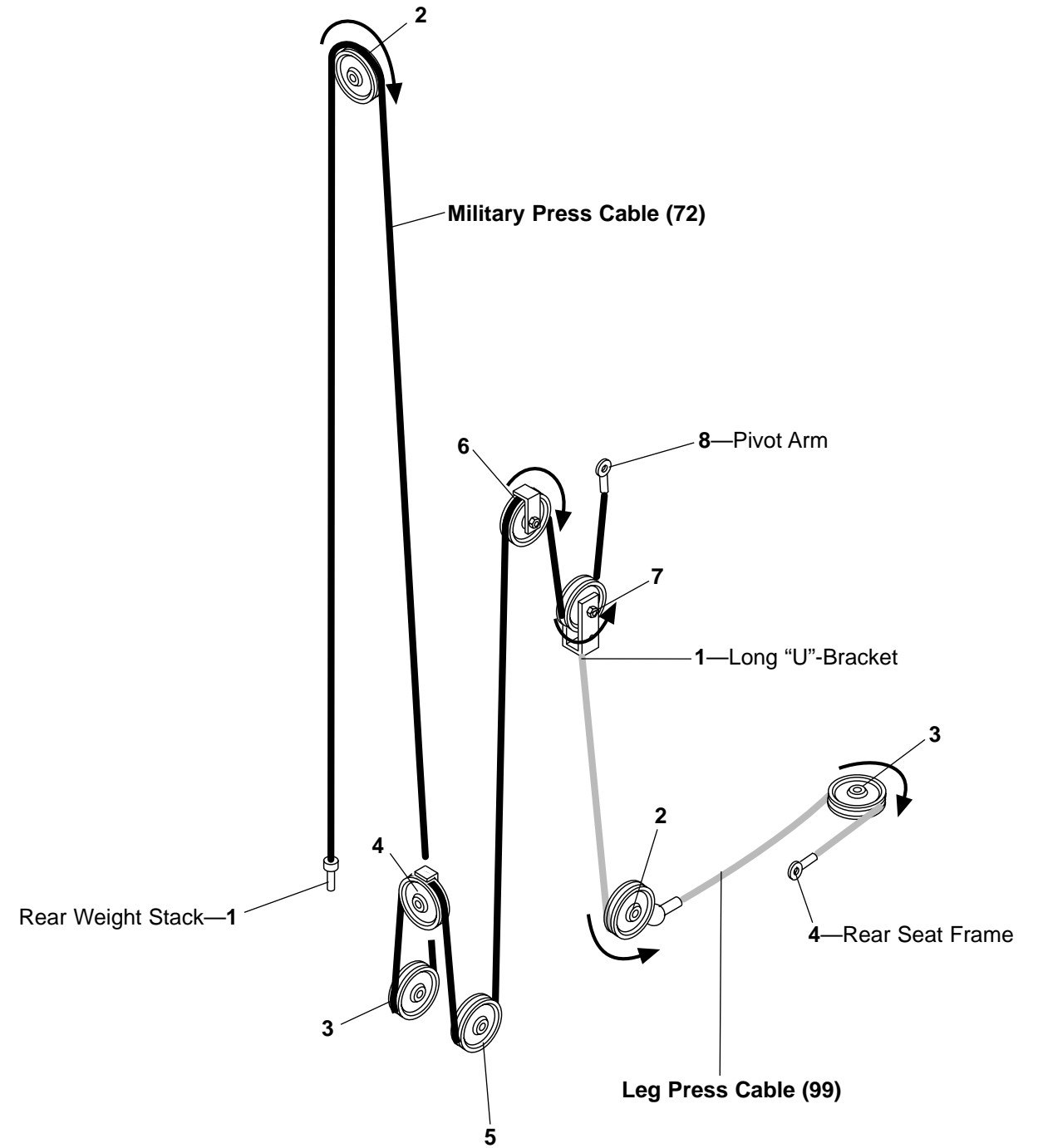

CABLE DIAGRAMS

The cable diagrams on these pages show the proper routing of the High Cable (58), the Low Cable (23), the Military Press Cable (72), and the Leg Press Cable (99). Use the diagrams to be sure that the four cables and the cable traps have been assembled correctly. If the cables have not been correctly routed, the home gym system will not function properly and damage may occur. The insets show the proper positioning of the cable traps. The cable traps should be positioned so that the cables will not come off the pulleys. **Be sure that the cable traps do not touch or bind the cables.**

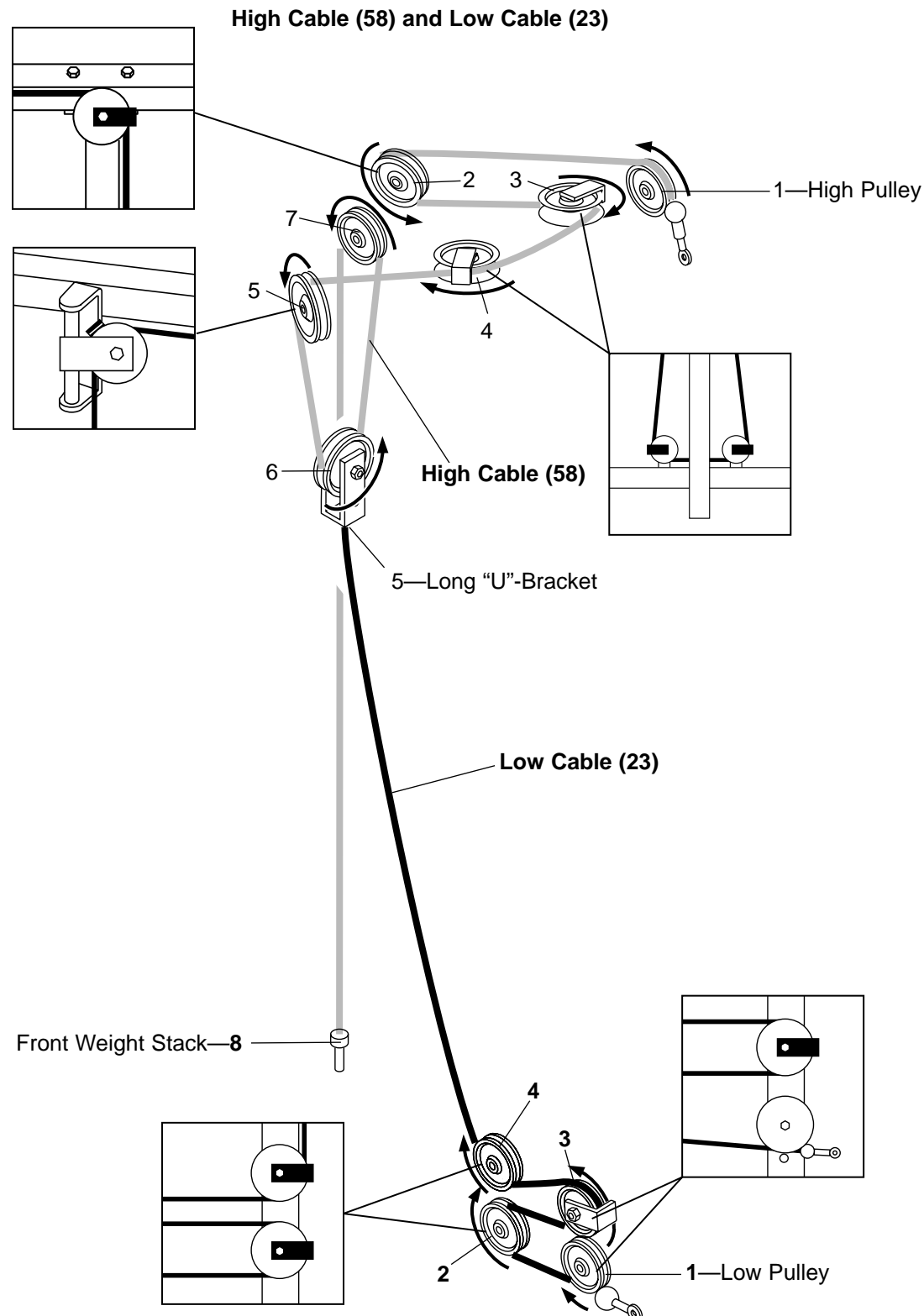

BEFORE YOU BEGIN

Thank you for selecting the versatile WEIDER® PRO 9645 Home Gym System. The PRO 9645 offers a selection of weight stations designed to develop every major muscle group of the body. Whether your goal is to tone your body, build dramatic muscle size and strength, or improve your cardiovascular system, the PRO 9645 will help you to achieve the specific results you want.

If you have additional questions, please call our Customer Service Department. To help us assist you, please note the product model number and serial number before calling. The model number is WESY96450. The serial number can be found on a decal attached to the WEIDER® PRO 9645 (see the front cover of this manual).

For your benefit, read this manual carefully before using the WEIDER® PRO 9645 Home Gym System.

Before reading further, please review the drawing below and familiarise yourself with the parts that are labelled.

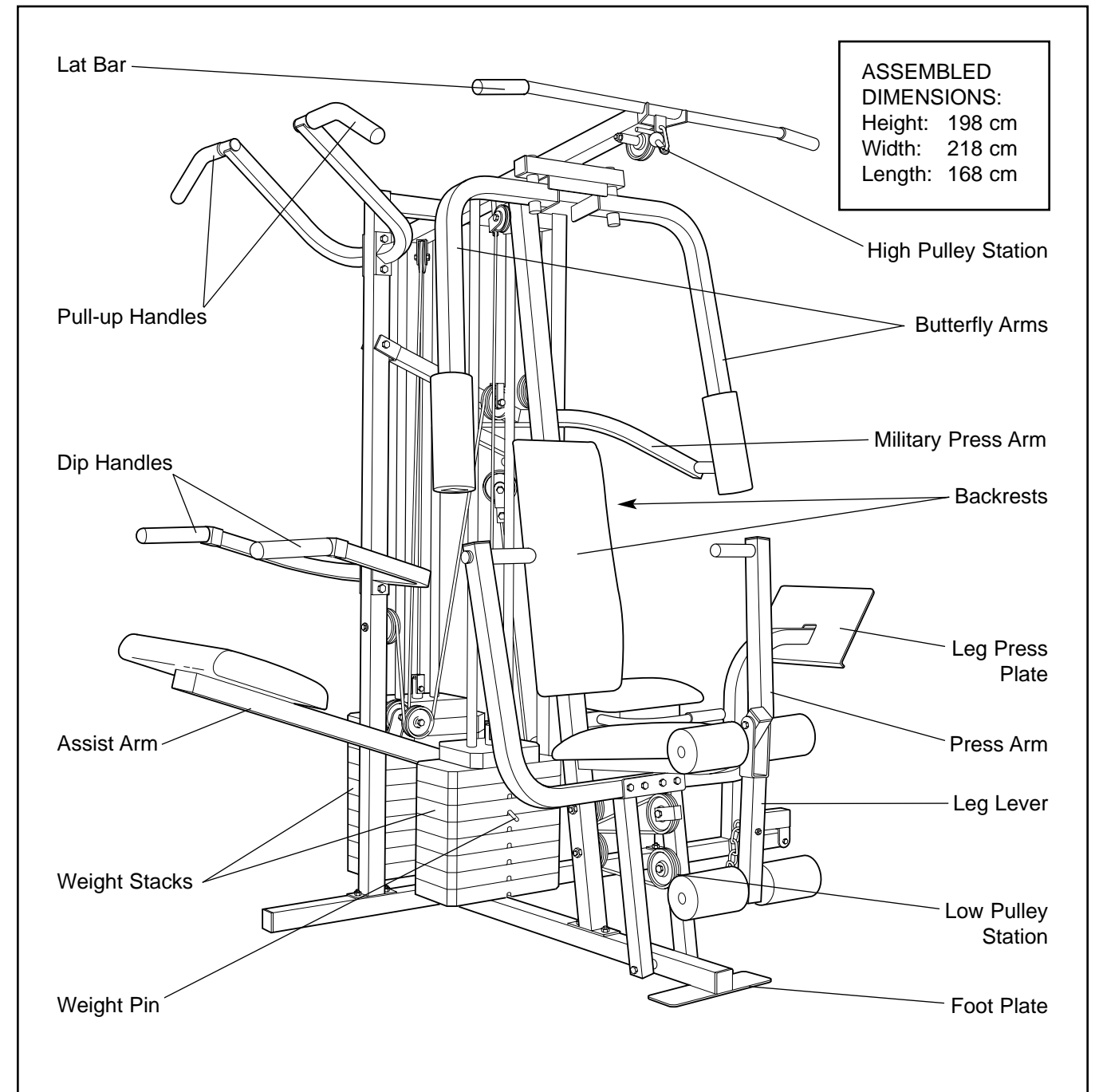

ASSEMBLY



Before beginning assembly, carefully read the following information and instructions:

- Place all parts of the PRO 9645 in a cleared area and remove the packing materials; do not dispose of the packing materials until assembly is completed.
- The assembly is broken into four stages: 1) frame assembly, 2) arm assembly, 3) cable and pulley assembly, and 4) seat and backrest assembly. The hardware for each stage is packaged separately.
- Wait until you begin each assembly stage to open the parts bag labelled for that assembly stage.
- For help identifying the small parts used in assembly, use the **PART IDENTIFICATION CHART** located in the centre of this manual. Note: Some small parts may have been pre-attached for shipping. If a part is not in the parts bag, check to see if it has been pre-attached.

- As you assemble the PRO 9645 be sure that all parts are oriented as shown in the drawings.

- Tighten all parts as you assemble them, unless instructed to do otherwise.

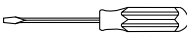
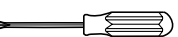
THE FOLLOWING TOOLS (NOT INCLUDED) ARE REQUIRED FOR ASSEMBLY:

- Two (2) adjustable spanners 
- One (1) standard screwdriver 
- One (1) phillips screwdriver 
- One (1) rubber mallet 
- Lubricant, such as grease or petroleum jelly, and soapy water will also be needed.

Assembly will be more convenient if you have the following tools: A socket set, a set of open-end or closed-end wrenches, or a set of ratchet wrenches.

- Before beginning assembly, be sure that you have read and understand the information in the box above.

Locate and open the parts bag labelled "FRAME ASSEMBLY."

Press two 2" Square Outer Caps (51) onto the Stabiliser (5). Press a 2" Square Inner Cap (27) into the Base (4).

Insert six 5/16" x 2 1/2" Carriage Bolts (1) up through the Stabiliser (5). Insert two 5/16" x 2 1/2" Carriage Bolts up through the Base (4).

Attach the Base (4) to the Stabiliser (5) with two 5/16" x 2 3/4" Bolts (11), two 5/16" Flat Washers (8), and two 5/16" Nylon Locknuts (3). **Do not tighten the Nylon Locknuts yet.**

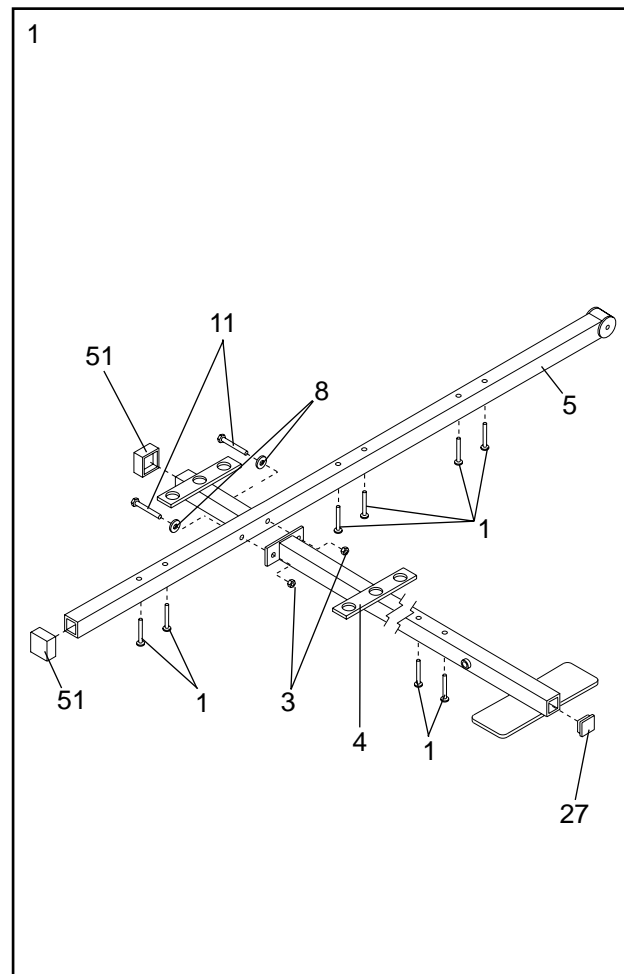

FRAME ASSEMBLY

TROUBLE-SHOOTING AND MAINTENANCE

Inspect and tighten all parts each time you use the home gym system. Replace any worn parts immediately. The home gym system can be cleaned using a damp cloth and mild non-abrasive detergent. Do not use solvents.

TIGHTENING THE CABLES

Woven cable, the type of cable used on the home gym system, can stretch slightly when it is first used. If there is slack in the cables before resistance is felt, the cables should be tightened. If any slack is felt when using the front weight stack, both the High Cable (58) and the Low Cable (23) will need to be tightened. If any slack is felt when using the rear weight stack, both the Military Press Cable (72) and the Leg Press Cable (99) will need to be tightened.

To tighten the cables, insert the weight pin into the middle of the weight stack. Slack can be removed from these cables several ways:

- See drawing 1. Tighten the 1/4" Nylon Locknut (2) that connects the end of the Low Cable (23) to the Long "U"-Bracket (57).

The Leg Press Cable (99) can be tightened in the same manner.

- See drawing 1. Move the 3 1/2" Pulley (15) to the other hole in one of the Long "U"-Brackets (57). Remove the 3/8" Nylon Locknut (21) and the 3/8" x 2" Bolt (12) from the Cable Trap (66), Pulley, and Long "U"-Bracket. Re-attach the Pulley and Cable Trap. Be sure that the Cable Trap is in the proper position and that the Cable and Pulley move smoothly.

The other Long "U"-Bracket (57) can be adjusted in the same manner.

- See drawing 2. Tighten the 1/4" Nylon Locknut (2) that connects the end of the High Cable (58) to the Small "U"-Bracket (71).

The Military Press Cable (72) can be tightened in the same manner.

- See Drawing 3. If additional slack is felt while using the Leg Press Arm (96), then the end of the Leg Press Cable (99) must be moved to the next hole in the Rear Seat Frame (100). Remove the 5/16" x 2 3/4" Bolt (11), the 5/16" Washer (8), the end of the Cable, and both 5/16" Nylon Jam Nuts (93) from the Rear Seat Frame. Re-attach the Bolt, the Washer, the end of the Cable, and both Nylon Jam Nuts to the next hole in the Rear Seat Frame.

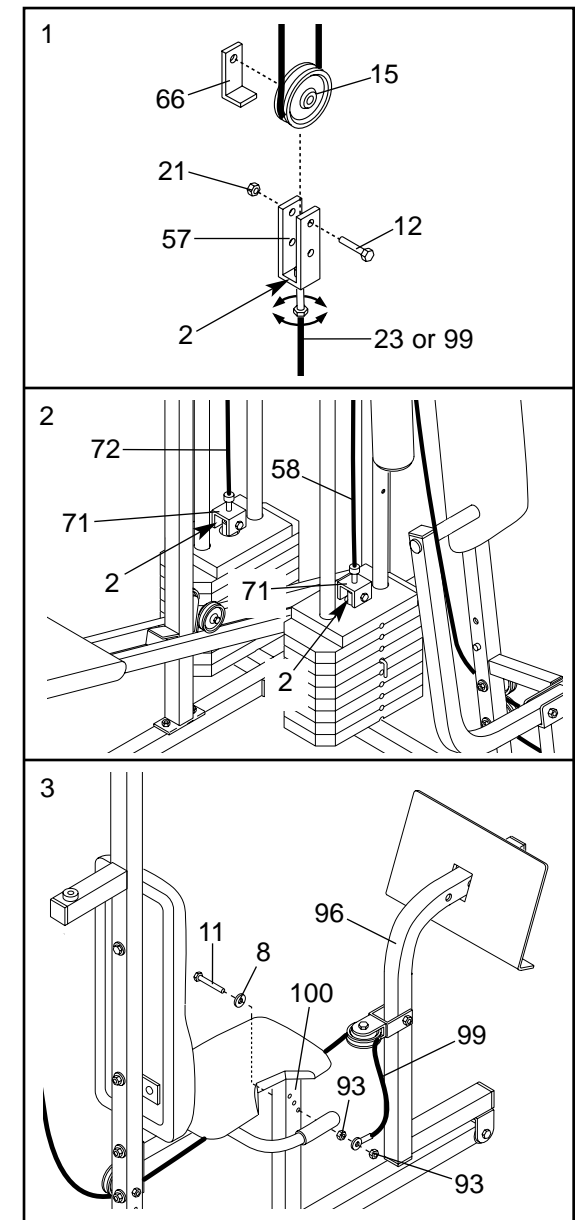

Do not overtighten the cables; the top weight will be lifted off the weight stack. If a cable tends to slip off the pulleys often, it may have become twisted. Remove the cable and re-install it.

The cables need to be replaced every two years. If the cables need to be replaced, see ORDERING REPLACEMENT PARTS on the back cover of this manual.

WEIGHT RESISTANCE CHART

This chart shows the approximate weight resistance at each weight station. "Top" refers to the 6,5 lb. top weight. The other numbers refer to the 12,5 lb. weight plates. The butterfly arm resistance listed is the resistance for each butterfly arm.

WEIGHT PLATES	PRESS ARM (lbs.)	BUTTERFLY ARM (lbs.)	LEG LEVER (lbs.)	HIGH PULLEY (lbs.)	LOW PULLEY (lbs.)	MILITARY PRESS ARM (lbs.)	LEG PRESS (lbs.)	ASSIST ARM (lbs.)
Top	31	17	25	23	36	30	36	11
1	59	35	50	36	67	51	78	38
2	81	40	71	54	95	74	123	66
3	104	70	97	70	123	97	171	95
4	132	80	111	88	155	115	219	117
5	154	110	131	98	191	135	265	142
6	196	115	156	120	220	164	299	186
7	206	130	172	135	252	183	333	213
8	227	140	184	144	273	194	387	232
9	-	-	-	-	-	218	440	256
10	-	-	-	-	-	246	455	293

The actual resistance at each weight station may vary due to differences in individual weight plates, as well as friction between the cables, pulleys, and weight guides.

FRAME ASSEMBLY

- Slide the Assist Upright (74) and the Leg Press Upright (56) onto the indicated 5/16" x 2 1/2" Carriage Bolts (1) in the Stabiliser (5). **The high side of the brackets on the Assist Upright and Leg Press Upright should be on the side shown. Hand-tighten four 5/16" Nylon Locknuts (3) onto the Carriage Bolts. Do not tighten the Nylon Locknuts yet.**

Press two 2" Square Inner Caps (27) into the Leg Press Upright (56). Press a 2" Square Inner Cap into the Assist Upright (74).

Attach the Rubber Bumper (91) to the Leg Press Upright (56) with the #8 x 1/2" Self-tapping Screw (87).

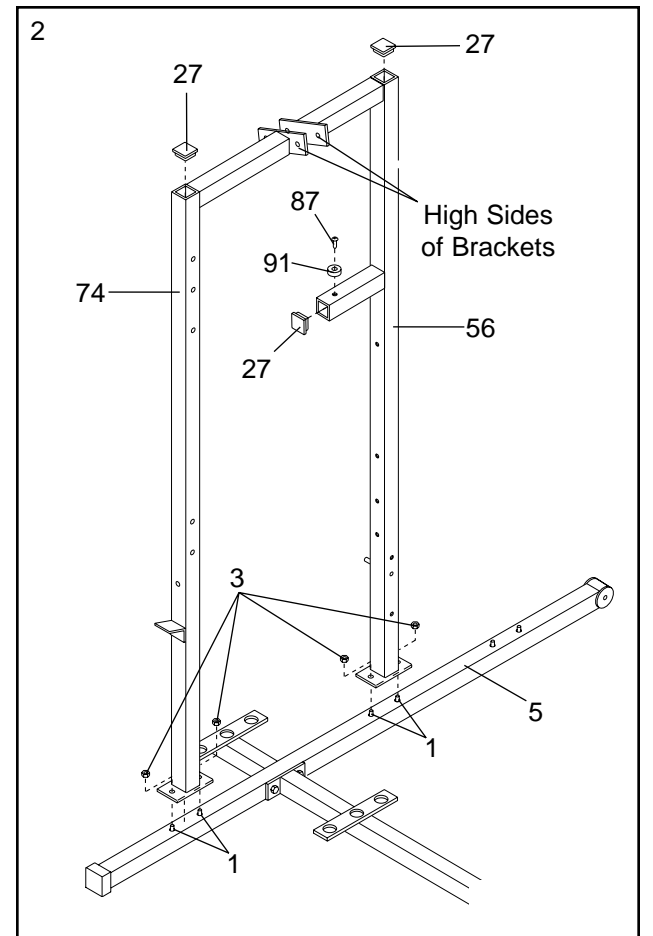

- Slide the Front Upright (42) onto the 5/16" x 2 1/2" Carriage Bolts (1) in the Base (4). Hand-tighten a 5/16" Nylon Locknut (3) onto each Carriage Bolt. **Do not tighten the Nylon Locknuts yet.**

Press a 1" Square Inner Cap (6) into the Front Upright (42).

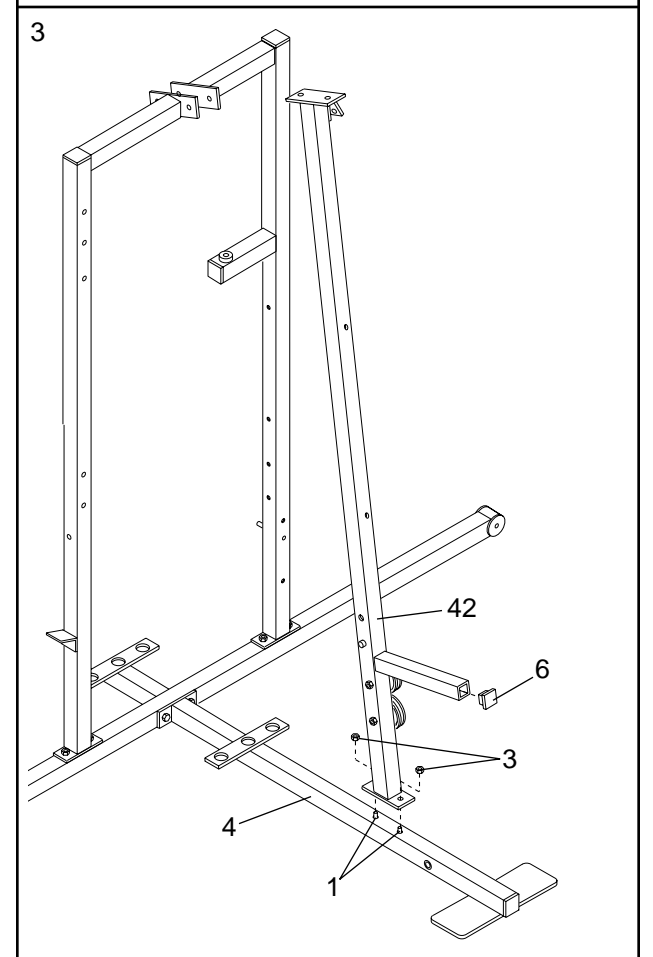

- Press a 2" Square Inner Cap (27) into the end of the Top Frame (55). Press a 1 3/4" Square Inner Cap (44) into each end of the crossbar on the Top Frame. Press two 1" Round Inner Caps (49) into the top of the crossbar.

Attach the Top Frame (55) to the Assist Upright (74) and the Leg Press Upright (56) with two 5/16" x 2 3/4" Bolts (11) and two 5/16" Nylon Locknuts (3).

Attach the Top Frame (55) to the Front Upright (42) with two 5/16" x 2 3/4" Bolts (11), two 5/16" Flat Washers (8), and two 5/16" Nylon Locknuts (3).

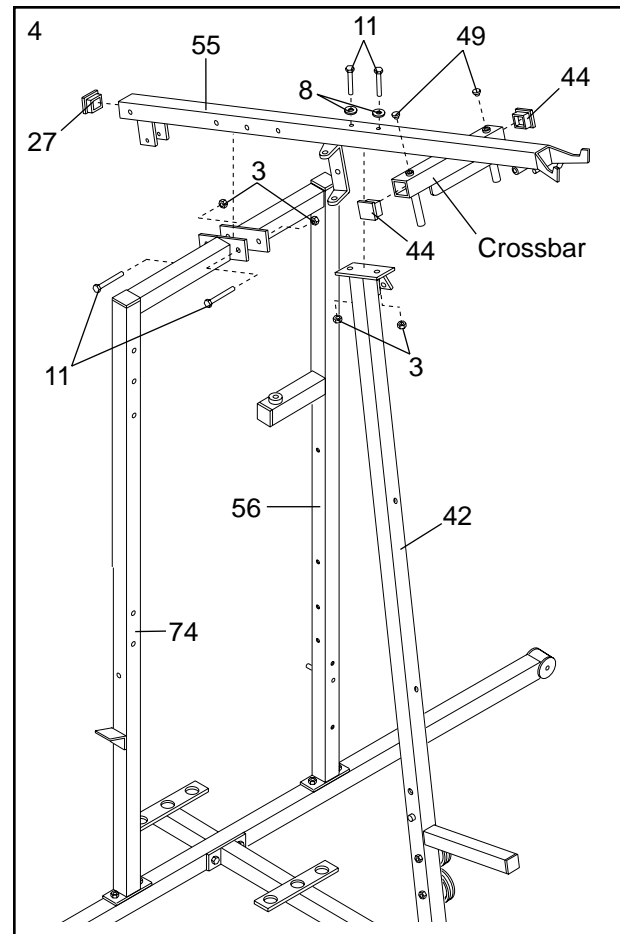

- Slide the Rear Seat Frame (100) onto the indicated 5/16" x 2 1/2" Carriage Bolts (1) in the Stabiliser (5). Hand-tighten two 5/16" Nylon Locknuts (3) onto the Carriage Bolts. **Do not tighten the Nylon Locknuts yet.**

Attach the other end of the Rear Seat Frame (100) to the Leg Press Upright (56) with two 5/16" x 2 3/4" Bolts (11), two 5/16" Flat Washers (8), and two 5/16" Nylon Locknuts (3).

Attach the Handle (82) to the Rear Seat Frame (100) with two 5/16" x 2 1/2" Carriage Bolts (1) and two 5/16" Nylon Locknuts (3).

Tighten all Nylon Locknuts used in steps 1-5.

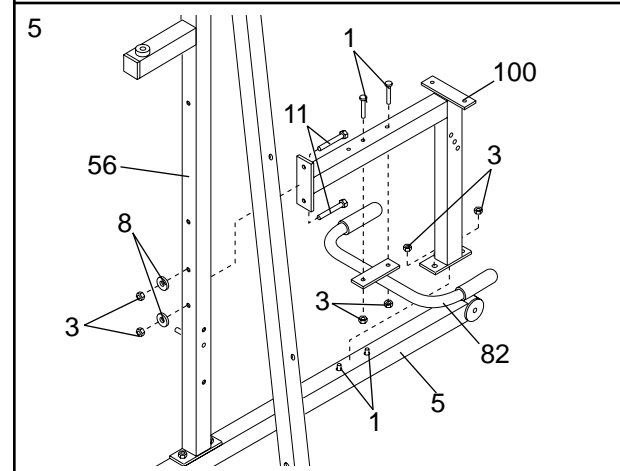

- Set two Weight Bumpers (19) on the bracket on the Base (4) as shown. Set two Weight Bumpers (19) on the bracket on the Stabiliser (5).

Stack ten Weights (25) onto the bracket on the Stabiliser (5). Stack eight Weights onto the bracket on the Base (4). **Be sure that the pin grooves are all on the same side of each stack of Weights.**

Be careful not to tip either stack of Weights (25) until step 8 is complete.

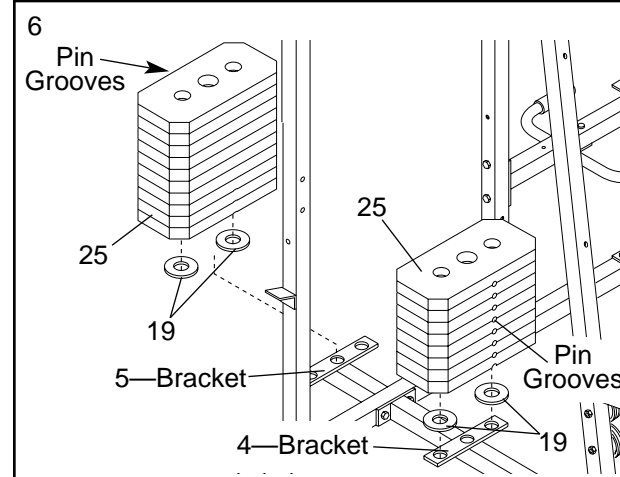

ATTACHING AND REMOVING THE SEAT

To attach the Seat (13), set the bracket on the Front Seat Frame (36) onto the indicated pins on the Front Upright (42). Attach the Front Seat Frame to the Front Upright with the 5/16" x 2 3/4" Carriage Bolt (14) and the Seat Knob (40).

For some exercises, the Seat (13) must be removed. First, be sure that the chain is not attached to the leg lever. Next, remove the Seat Knob (40) and the 5/16" x 2 3/4" Carriage Bolt (14) from the Seat Frame (36). Lift the Front Seat Frame off the Front Upright (42).

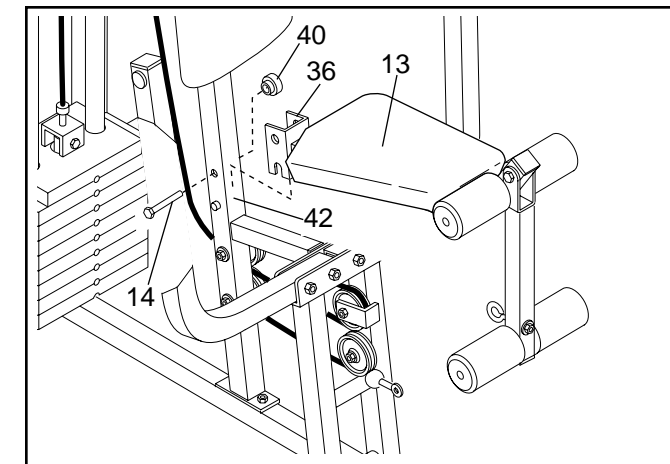

ATTACHING THE LEG LEVER TO THE LOW PULLEY STATION

To use the Leg Lever (29), the seat must be attached to the front upright (see ATTACHING AND REMOVING THE SEAT above).

Attach one end of the Chain (52) to the Short Cable (23) with a Cable Clip (53). Attach the other end of the Chain to the Eyebolt (35) with a Cable Clip.

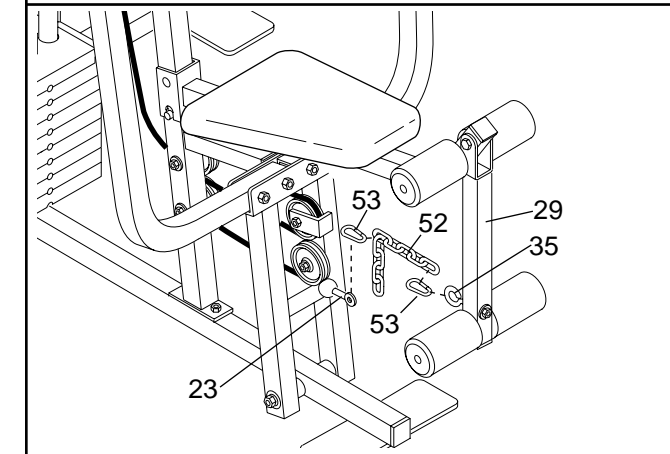

ADJUSTING THE LEG PRESS PLATE

Remove the Press Pin (97) from the Leg Press Plate (95) and the Leg Press Arm (96).

Align the welded tubes on the Leg Press Plate (95) with the desired set of holes in the Leg Press Arm (96). Re-insert the Press Pin (97) through the welded tubes on Leg Press Plate and the holes in the Leg Press Arm.

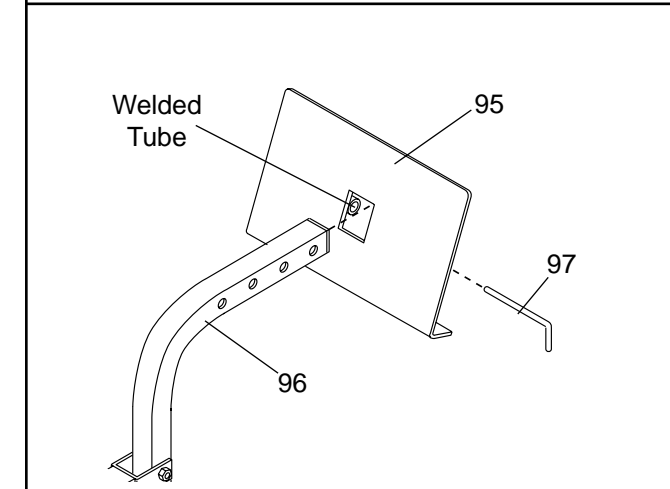

HOW TO USE THE HOME GYM SYSTEM

The instructions below describe how each part of the home gym system can be adjusted.

IMPORTANT: When attaching the lat bar or nylon strap, make sure that the attachments are in the correct starting position for the exercise to be performed. If there is any slack in the cables or chain as an exercise is performed, the effectiveness of the exercise will be reduced.

CHANGING THE WEIGHT SETTING

The PRO 9645 features two weight stacks. The front weight stack is connected to the upper and lower pulleys, the press arm, and the butterfly arms. The rear weight stack is connected to the military press arm, assist arm, and leg press.

To change the weight setting of either weight stack, insert a Weight Pin (26) under the desired Weight (25). Insert the Weight Pin until the bent end of the Weight Pin is touching the Weights, and turn the bent end downward. The weight setting of either weight stack can be changed from 6.5 pounds to 106.5 pounds, in increments of 12.5 pounds. **Note: Due to the cables and pulleys, the amount of resistance at each exercise station may vary from the weight setting. Use the WEIGHT RESISTANCE CHART on page 24 to find the approximate amount of resistance at each weight station.**

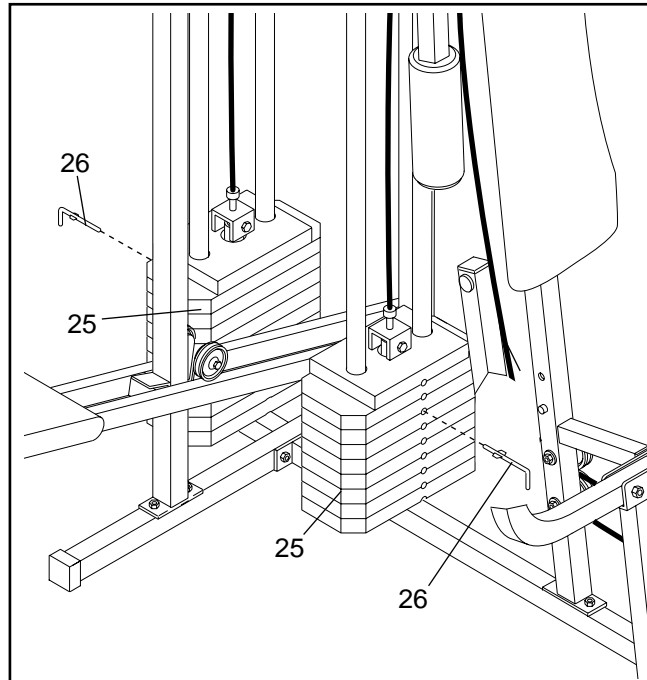

ATTACHING THE LAT BAR OR NYLON STRAP TO THE HIGH PULLEY STATION

Attach the Lat Bar (54) to the High Cable (58) with a Cable Clip (53). For some exercises, the Chain (52) should be attached between the Lat Bar and the High Cable with two Cable Clips. **Adjust the length of the Chain between the Lat Bar and the High Cable so the Lat Bar is in the correct starting position for the exercise to be performed.**

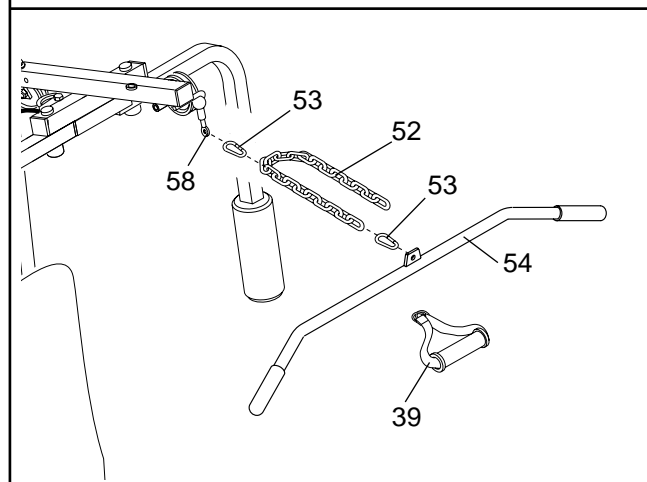

The Nylon Strap (39) can be attached in the same manner.

ATTACHING THE LAT BAR OR NYLON STRAP TO THE LOW PULLEY STATION

Attach the Lat Bar (54) to the Low Cable (23) with a Cable Clip (53). For some exercises, the Chain (52) should be attached between the Lat Bar and the Low Cable with two Cable Clips. **Adjust the length of the Chain between the Lat Bar and the Low Cable so the Lat Bar is in the correct starting position for the exercise to be performed.**

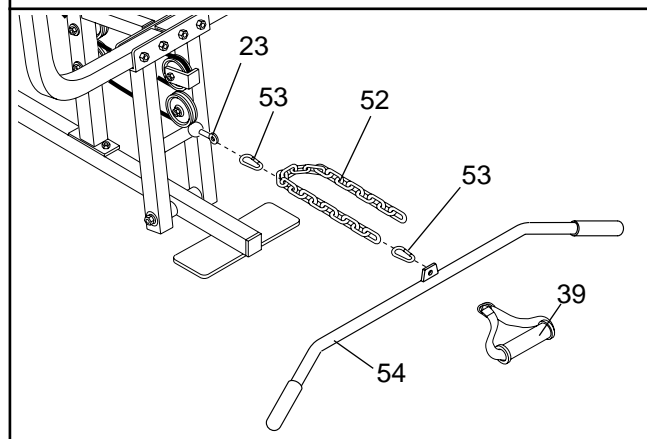

The Nylon Strap (39) can be attached in the same manner.

FRAME ASSEMBLY

- Press a Weight Tube Bumper (64) into the end of the Short Weight Tube (108). Insert the Weight Tube into the front stack of Weights (25). **Be sure that the pin on the Weight Tube is sitting in the pin grooves in the top Weight.**

Lubricate the inside of the holes in a Top Weight (65). Set the Top Weight onto the front stack of Weights (25). Insert both Long Weight Guides (62) into the stack of Weights. **Be sure that the holes in the Weight Guides are at the top, as shown.**

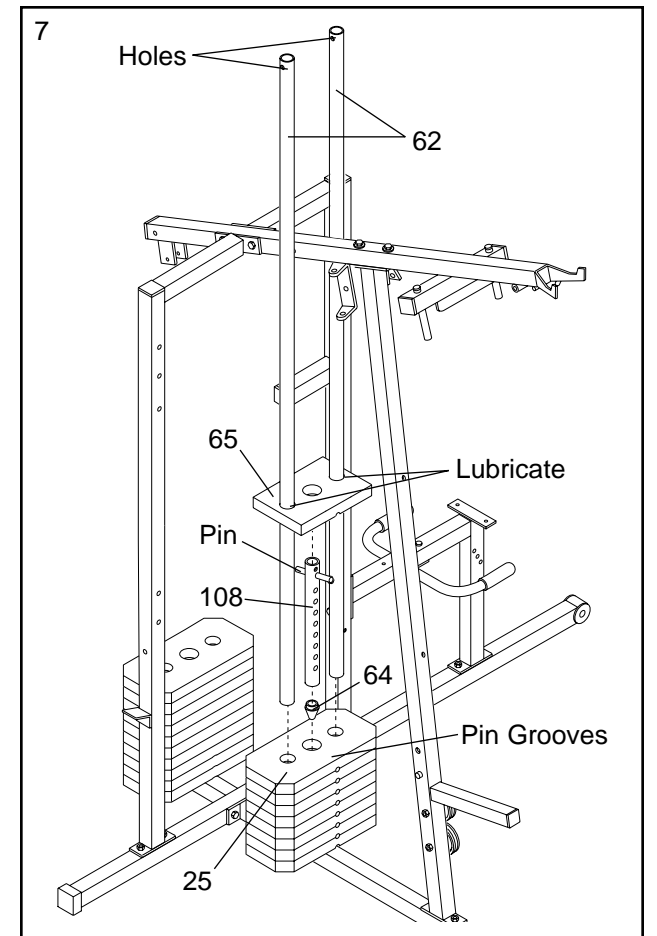

- Press a Weight Tube Bumper (64) into the end of the Long Weight Tube (63). Insert the Weight Tube into the rear stack of Weights (25). **Be sure that the pin on the Weight Tube is sitting in the pin grooves in the top Weight.**

Lubricate the inside of the holes in the other Top Weight (65). Set the Top Weight onto the rear stack of Weights (25). Insert both Short Weight Guides (73) into the stack of Weights. **Be sure that the holes in the Weight Guides are at the top, as shown.**

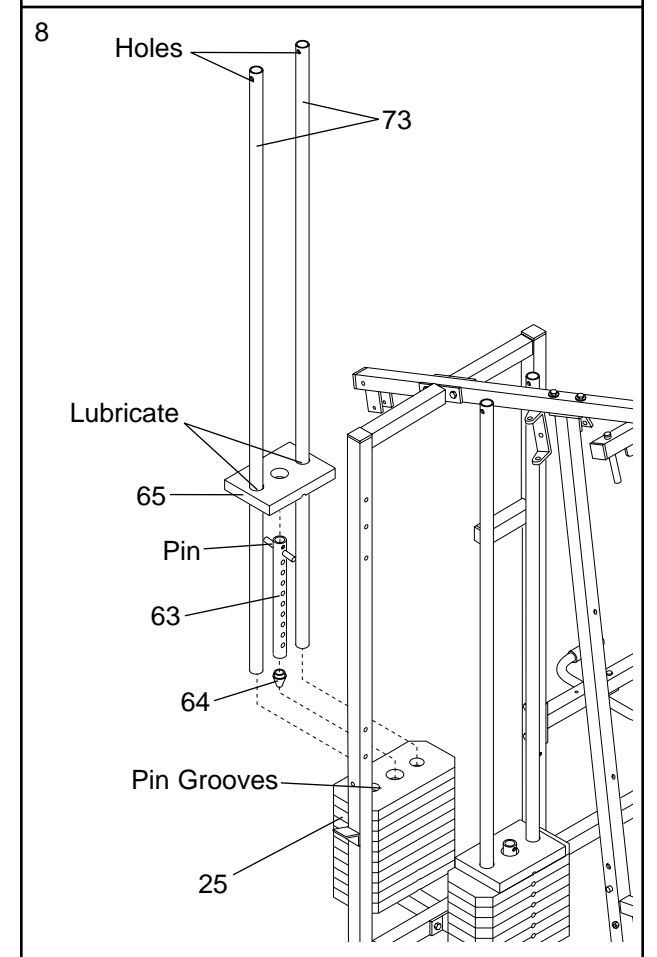

9. Attach the upper ends of the Short Weight Guides (73) to the Top Frame (55) with a 5/16" x 6" Bolt (60), two 1/2" x 3/4" Spacers (61), and a 5/16" Nylon Locknut (3).

Attach the upper ends of the Long Weight Guides (62) to the Top Frame (55) in the same manner.

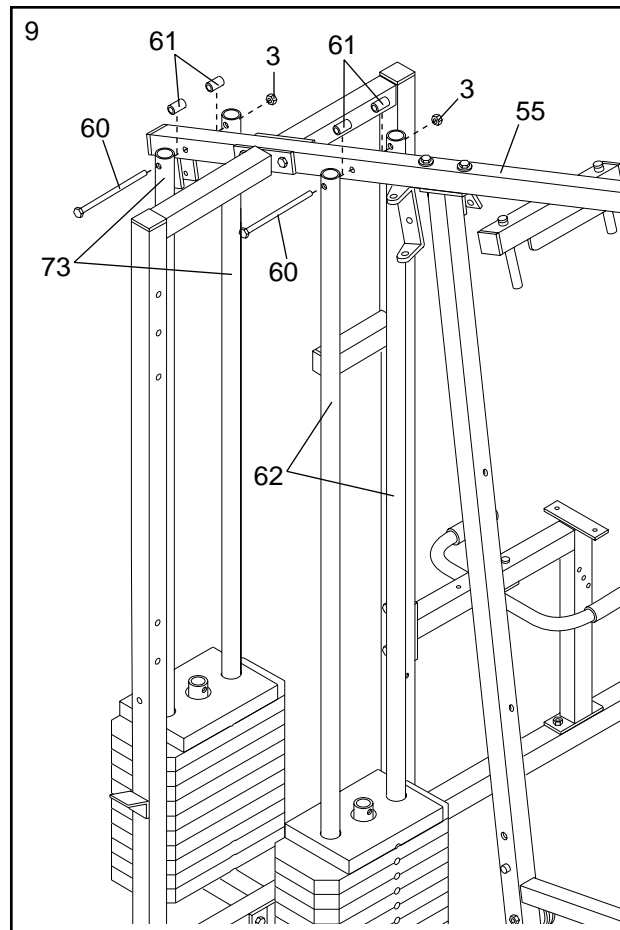

10. Locate and open the parts bag labelled "ARM ASSEMBLY."

Be sure there is a Bushing (98) in each side of the Stabiliser (5). Press a 2" Square Inner Cap (27) into each end of the Leg Press Arm (96).

Lubricate a 3/8" x 3 1/4" Bolt (67). Attach the Leg Press Arm (96) to the Stabiliser (5) with the Bolt and a 3/8" Nylon Locknut (21). **Do not over-tighten the Nylon Locknut. The Leg Press Arm must be able to pivot freely.**

Align the welded tubes on the Leg Press Plate (95) with one set of holes in the Leg Press Arm (96). Attach the Leg Press Plate to the Leg Press Arm with the Press Pin (97).

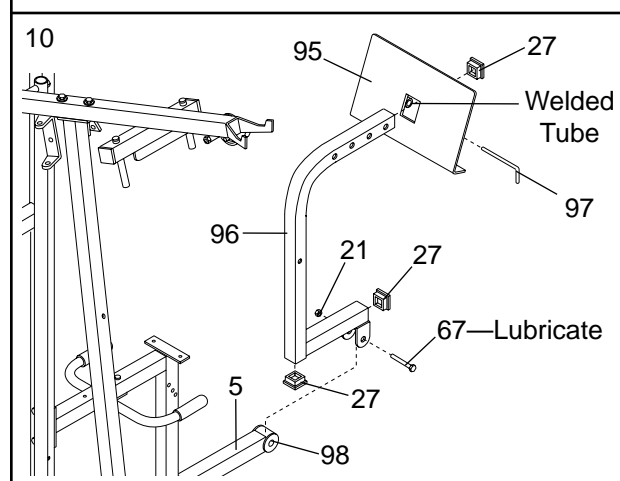

11. Press a 1" x 7/8" Plastic Bushing (90) onto each welded spacer on the Press Frame (17). Slide the Press Frame into place onto the Base (4). **Note: This will be a tight fit. The Plastic Bushings should fit on each end of the indicated tube in the Base. Make sure that the pulleys are on the side shown.**

Lubricate the 3/8" x 8" Bolt (59). Attach the Press Frame (17) to the Base (4) with the Bolt and a 3/8" Nylon Locknut (21).

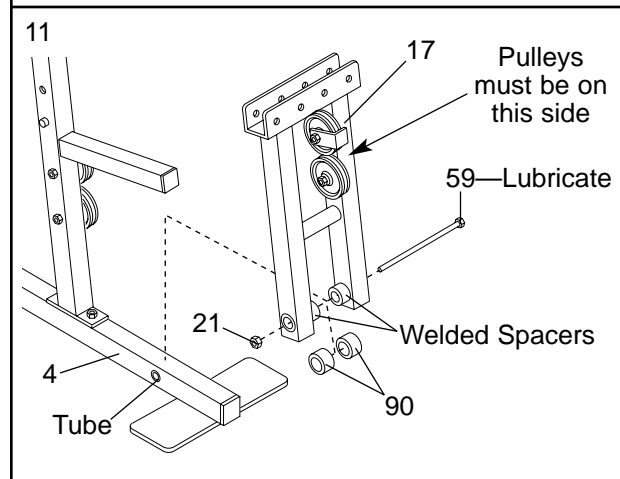

47. Press two 3/4" Round Inner Caps (34) into each Pad Tube (28).

Insert a Pad Tube (28) into the Front Seat Frame (36). Slide a Foam Pad (30) onto each end of the Pad Tube.

Insert the other Pad Tube (28) into the Leg Lever (29). Slide a Foam Pad (30) onto each end of the Pad Tube.

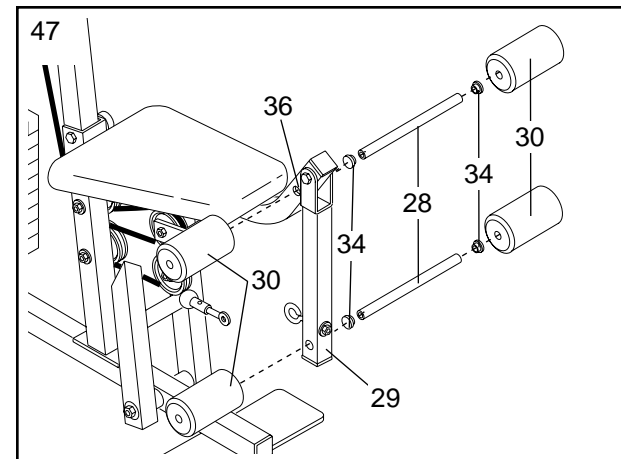

48. Remove the backing from the PRO 9645 decal and apply it to the home gym system as shown.

Make sure that all parts have been properly tightened. The use of the remaining parts will be explained in HOW TO USE THE HOME GYM SYSTEM, beginning on page 22 of this manual.

Before using the home gym system, pull each cable a few times to be sure that the cables move smoothly over the pulleys. If one of the cables does not move smoothly, find and correct the problem. **IMPORTANT: If the cables are not properly installed, they may be damaged when heavy weight is used. See the CABLE DIAGRAMS on pages 26 and 27 of this manual for proper cable routing. If there is any slack in the cables, you will need to remove it by tightening the cables. See TROUBLE-SHOOTING AND MAINTENANCE on page 25.**

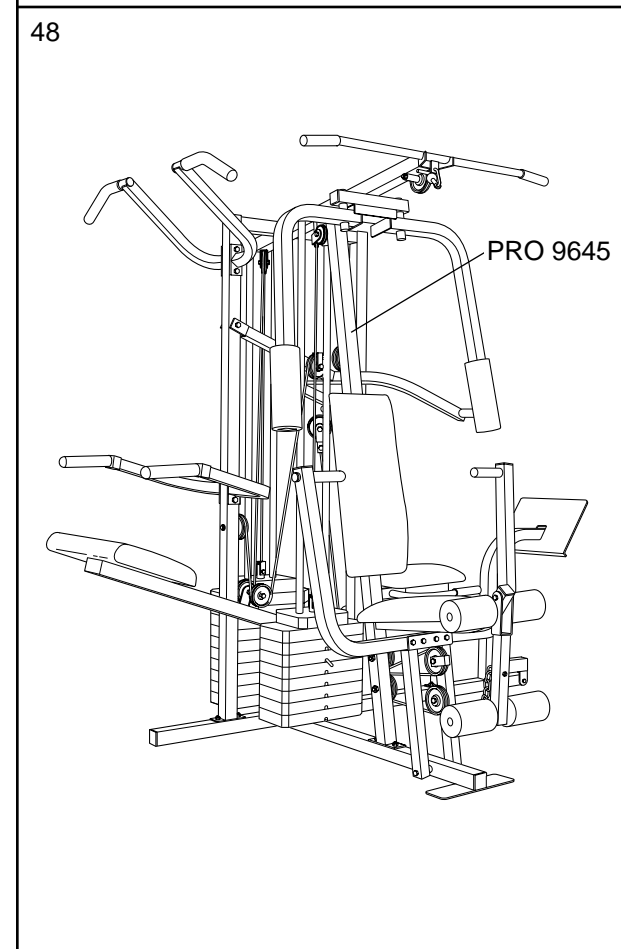

43. Attach the Front Backrest (41) to the Front Upright (42) with two 1/4" x 2 1/2" Screws (43) and two 1/4" Flat Washers (10). The Backrest must be oriented as shown.

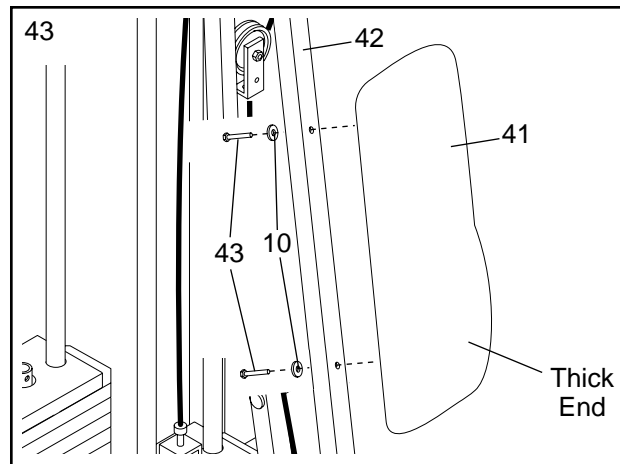

44. Press a 1 1/2" Square Inner Cap (32) into the Front Seat Frame (36).

Insert a 1/4" x 2" Carriage Bolt (38) through the centre hole in the Seat Plate (37). Attach the Seat Plate to the Seat (13) with two 1/4" x 1/2" Screws (18).

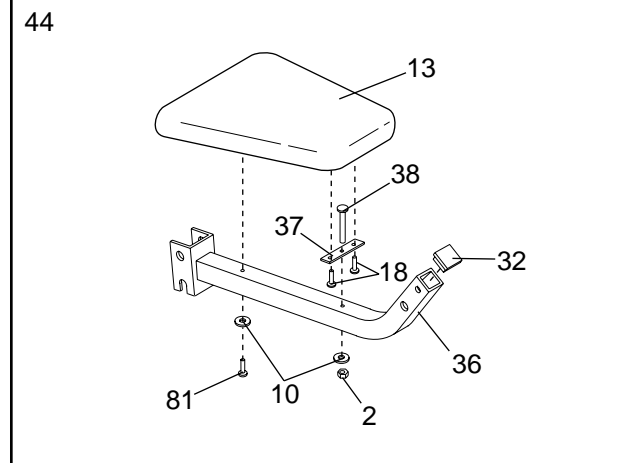

Insert the 1/4" x 2" Carriage Bolt (38) through the indicated hole in the Front Seat Frame (36). Tighten a 1/4" Nylon Locknut (2) with a 1/4" Flat Washer (10) onto the Carriage Bolt.

Attach the other end of the Seat (13) to the Front Seat Frame (36) with a 1/4" Flat Washer (10) and a 1/4" x 2" Machine Screw (81).

45. Press a 1 1/2" Square Inner Cap (32) into the Leg Lever (29).

Lubricate the 5/16" x 2 1/4" Bolt (33). Attach the Leg Lever (29) to the Front Seat Frame (36) with the Bolt and a 5/16" Nylon Locknut (3).

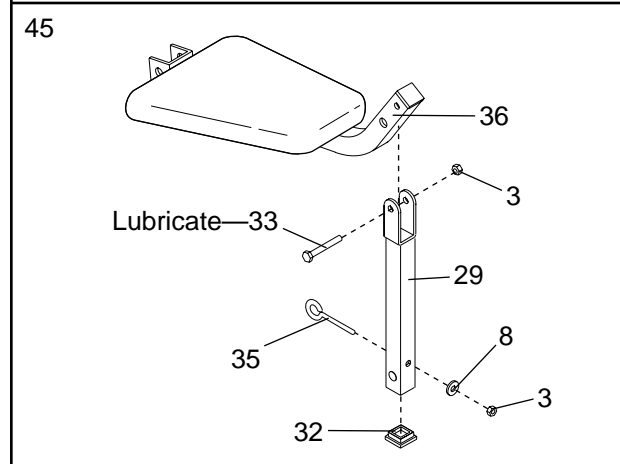

Insert the 5/16" x 2" Eyebolt (35) into the Leg Lever (29) from the direction shown. Tighten a 5/16" Nylon Locknut (3) with a 5/16" Flat Washer (8) onto the Eyebolt.

46. Rest the Front Seat Frame (36) on the indicated pin in the Front Upright (42). Attach the Front Seat Frame to the Front Upright with a 5/16" x 2 3/4" Carriage Bolt (14) and the Seat Knob (40).

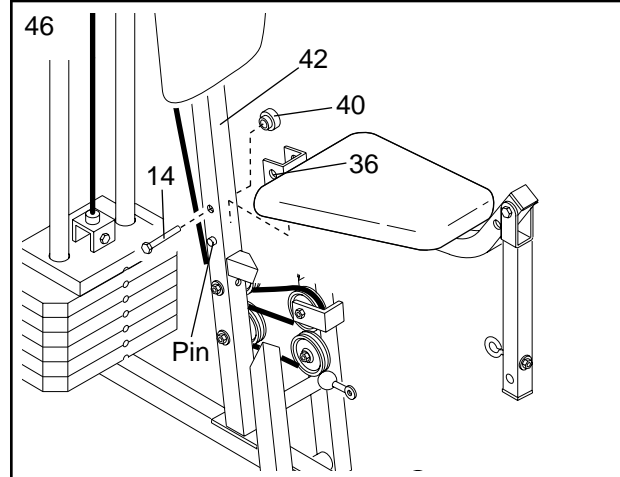

12. Press a 1" Round Inner Cap (49) into one of the Press Arms (46). Press a 1 3/4" Square Inner Cap (44) into the Press Arm.

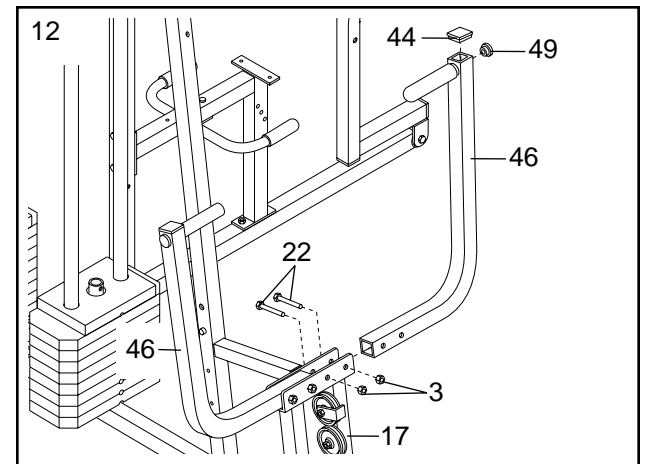

Attach the Press Arm (46) to one side of the Press Frame (17) with two 5/16" x 2 1/2" Bolts (22) and two 5/16" Nylon Locknuts (3).

Assemble the other Press Arm (46) in the same manner.

13. Identify the Right Arm (48) and the Left Arm (47). Note the position of the welded bracket on each Arm. **Arm identification is very important for step 14.**

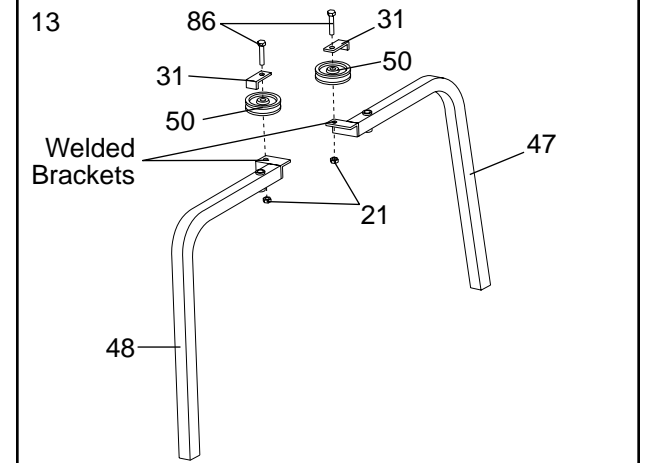

Attach a "V"-Pulley (50) and a Long Cable Trap (31) to the Right Arm (48) with a 3/8" x 2 1/2" Bolt (86) and a 3/8" Nylon Locknut (21). **Do not tighten the Nylon Locknut yet.**

Attach a "V"-Pulley (50) and a Long Cable Trap (31) to the Left Arm (47) in the same manner.

14. Lubricate both axles on the Top Frame (55).

Slide the Right Arm (48) onto the right axle. **Note: Be careful not to confuse the Right Arm with the Left Arm (47); refer to step 13 to identify the Right Arm. Be sure that the upper end of the Right Arm is behind the indicated bracket on the Top Frame (55).**

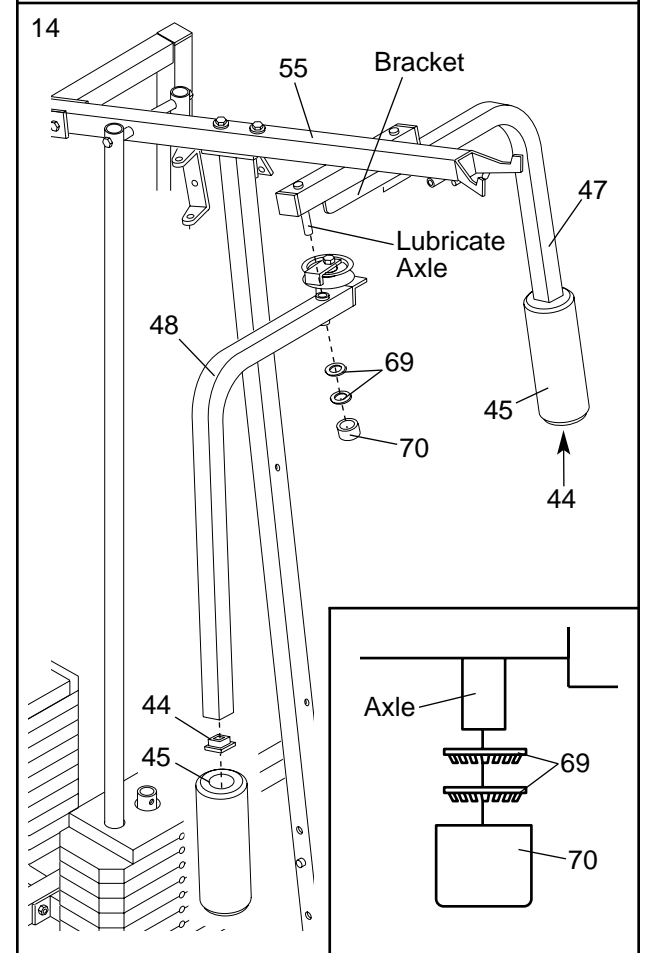

Tap two 1" Retainers (69) and a 1" Round Cover Cap (70) onto the axle. **Be sure that the teeth on the Retainers bend toward the Round Cover Cap, as shown in the inset drawing.**

Attach the Left Arm (47) in the same manner.

Press 1 3/4" Square Inner Caps (44) into the lower ends of the Right and Left Arms (47, 48). Wet the lower end of each Arm with soapy water. Slide a 10" Pad (45) onto the lower end of each Arm.

15. See the inset drawing. Attach the Military Press Arm (84) to the Pivot Arm (101) with two 5/16" x 2 1/4" Bolts (33) and two 5/16" Nylon Locknuts (3).

Press two 1 1/2" Square Inner Caps (32) into the Military Press Arm (84). Press two 1" Round Inner Caps (49) into the Military Press Arm. Slide two 5" Plastic Handgrips (83) onto the Military Press Arm.

Attach the Pivot Arm (101) to the Assist Upright (74) with a 3/8" x 3 1/4" Bolt (67) and a 3/8" Nylon Locknut (21).

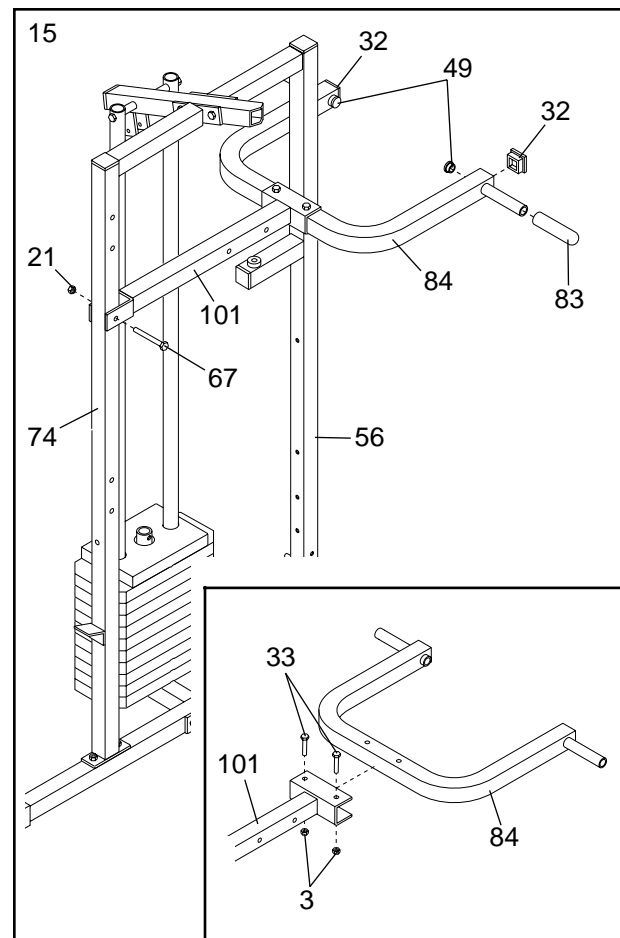

16. Press two 1" x 2" Inner Caps (107) into the Assist Arm (105).

Attach the Assist Arm (105) to the Leg Press Upright (56) with a 3/8" x 6" Bolt (106), two 3/8" Flat Washers (9), and a 3/8" Nylon Locknut (21). **See the inset drawing. The Assist Arm must be attached to the lowest hole in the Leg Press Upright (56). The Assist Arm must also be below the welded bracket on the Assist Upright (74).**

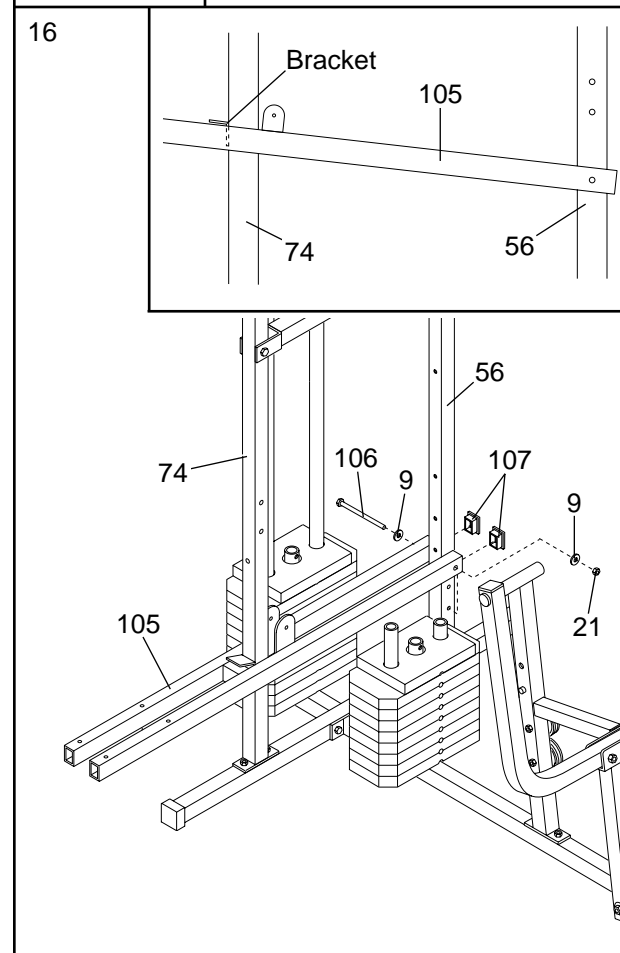

40. **Locate and open the parts bag labelled "SEAT ASSEMBLY."**

Insert a 1/4" x 2 1/2" Carriage Bolt (92) through the centre hole in a Seat Plate (37). Attach the Seat Plate to the Rear Backrest (85) with two 1/4" x 1/2" Screws (18).

Insert the 1/4" x 2 1/2" Carriage Bolt (92) through the indicated hole in the Leg Press Upright (56). Tighten a 1/4" Nylon Locknut (2) with a 1/4" Flat Washer (10) onto the Carriage Bolt. Attach the top of the Rear Backrest (85) to the Leg Press Upright with a 1/4" x 2 1/2" Screw (43) and a 1/4" Flat Washer (10).

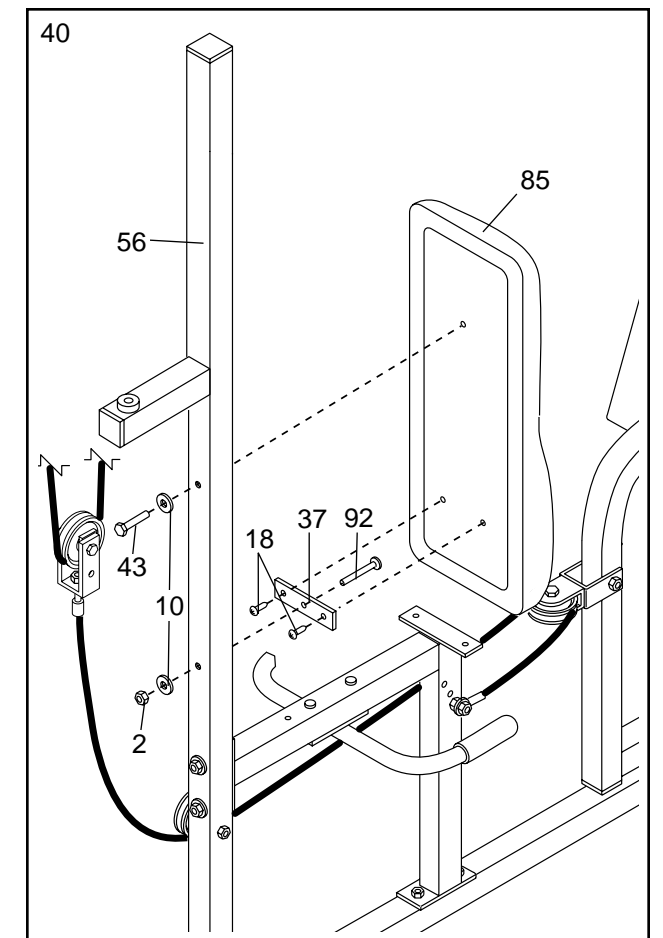

41. Attach one end of a Seat (13) to the Rear Seat Frame (100) with two 1/4" x 1/2" Screws (18). Attach the other end of the Seat to the Rear Seat Frame with a 1/4" Flat Washer (10) and a 1/4" x 2 1/2" Screw (43).

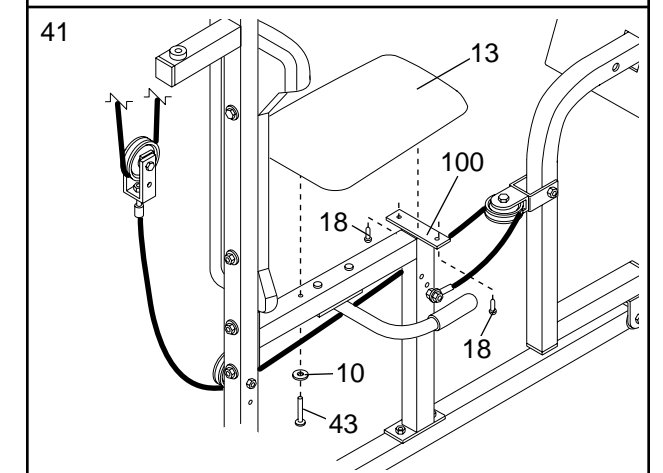

42. Attach the Assist Seat (104) and the Angle Bracket (110) to the Assist Arm (105) with four 1/4" Flat Washers (10) and four 1/4" x 2 1/2" Screws (43).

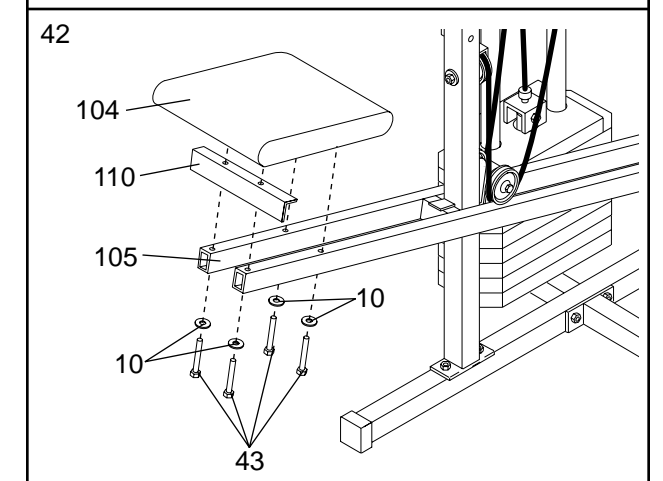

38. **Locate the Leg Press Cable (99).** Attach the end of the Leg Press Cable to the Long “U”-Bracket (57) with a 1/4” Nylon Locknut (2) and a 1/4” Flat Washer (10). **Do not completely tighten the Nylon Locknut. It should be threaded onto the end of the Cable only a couple of turns, as shown in the inset drawing.**

Wrap the Leg Press Cable (99) around a 3 1/2” Pulley (15). Attach the Pulley to the Leg Press Upright (56) with the 3/8” x 3 3/4” Bolt (88), a 3/8” Flat Washer (9), and a 3/8” Nylon Locknut (21). **The ball on the Cable must be on the indicated side of the Pulley. Be sure that the Cable and Pulley move smoothly and that the Cable is between the Pulley and the welded rod.**

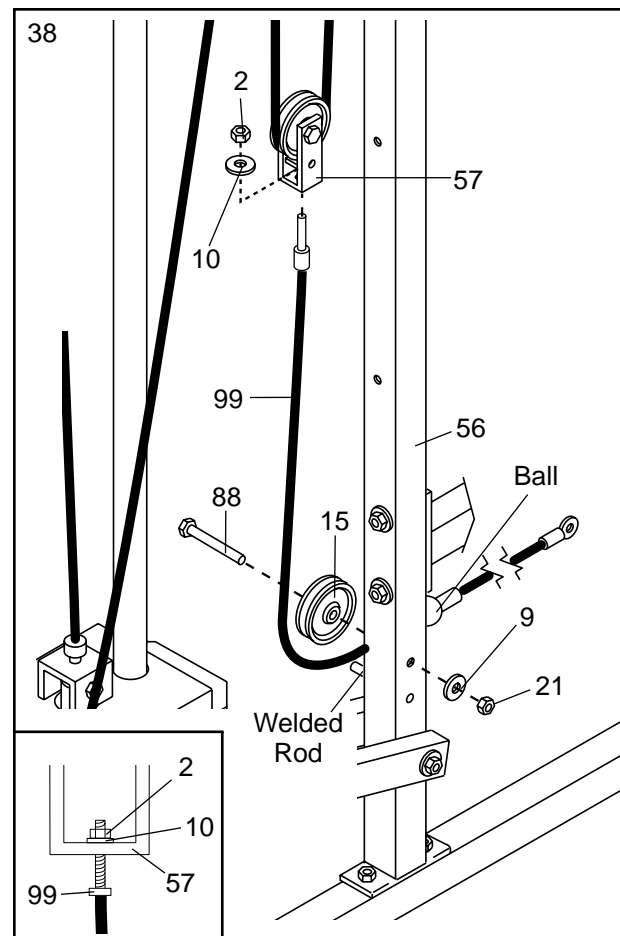

39. Attach the Press Bracket (94) to the Leg Press Arm (96) with a 5/16” x 3” Bolt (111) and a 5/16” Nylon Locknut (3).

Wrap the Leg Press Cable (99) around a 3 1/2” Pulley (15). Attach the Pulley to the Press Bracket (94) with the 3/8” x 2” Bolt (12) and a 3/8” Nylon Locknut (21).

Slide a 5/16” Flat Washer (8) onto a 5/16” x 2 3/4” Bolt (11). Insert the Bolt through the lowest hole in the Rear Seat Frame (100) from the indicated side. (Note: The three holes are for cable adjustment.) Tighten a 5/16” Nylon Jam Nut (93) onto the Bolt. Slide the end of the Leg Press Cable (99) onto the end of the Bolt. Thread another 5/16” Nylon Jam Nut onto the Bolt. **Do not fully tighten the second Jam Nut. There must be room between the two Jam Nuts for the end of the Cable to pivot.**

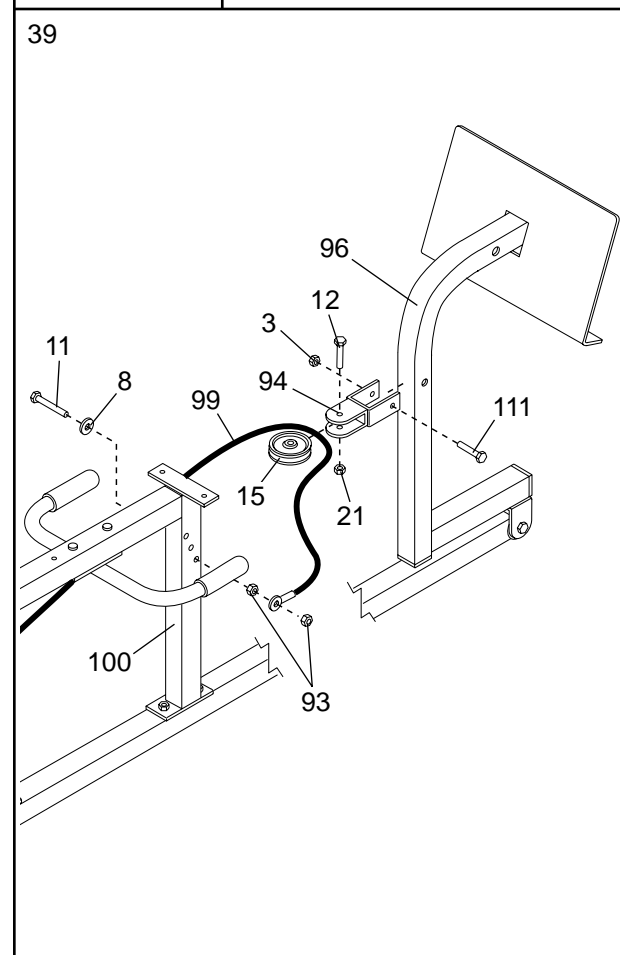

17. Attach the Left Pull-up Arm (75) and the Right Pull-up Arm (77) to the Assist Upright (74) with two 5/16” x 2 3/4” Bolts (11) and two 5/16” Nylon Locknuts (3).

Attach the Left Dip Arm (78) and the Right Dip Arm (79) to the Assist Upright (74) with two 5/16” x 2 3/4” Bolts (11) and two 5/16” Nylon Locknuts (3).

Wet the end of the Left Pull-up Arm (75) with soapy water. Slide a Long Handgrip (80) onto the Left Pull-up Arm.

Slide a Long Handgrip (80) onto the Right Pull-up Arm (77), onto the Left Dip Arm (78), and onto the Right Dip Arm (79) in the same manner.

Press two 1 1/4” Round Inner Caps (109) into the Left Pull-up Arm (75) and into the Right Pull-up Arm (77).

Press a 1 1/4” Round Inner Cap (109) into the Left Dip Arm (78), and into the Right Dip Arm (79).

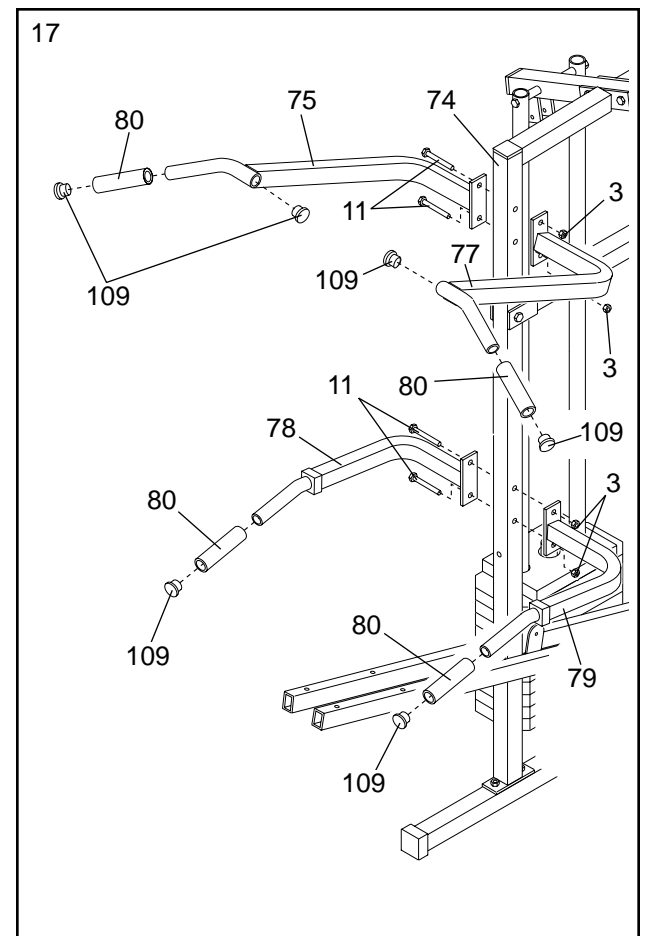

18. **Locate and open the parts bags labelled “CABLE ASSEMBLY” and “PULLEYS.”**

During steps 19 through 39, refer to the CABLE DIAGRAMS on pages 26–27 of this manual to verify proper cable routing. Before beginning this section, fully unwind the four Cables. Identify the four Cables by comparing the lengths and ends of the Cables. The approximate length of each Cable is listed (in inches) after the key number in the drawing.

IMPORTANT: While assembling the cables, do not overtighten the bolts and nuts attaching the pulleys. The pulleys must be able to turn freely.

19. **Locate the High Cable (58).** Wrap the High Cable around a 3 1/2” Pulley (15). Attach the Pulley to the Top Frame (55) with a 3/8” x 3 3/4” Bolt (88) and a 3/8” Nylon Locknut (21). **Be sure that the end of the Cable with the ball is on the indicated side of the Pulley and that the Cable is between the Pulley and the hook.**

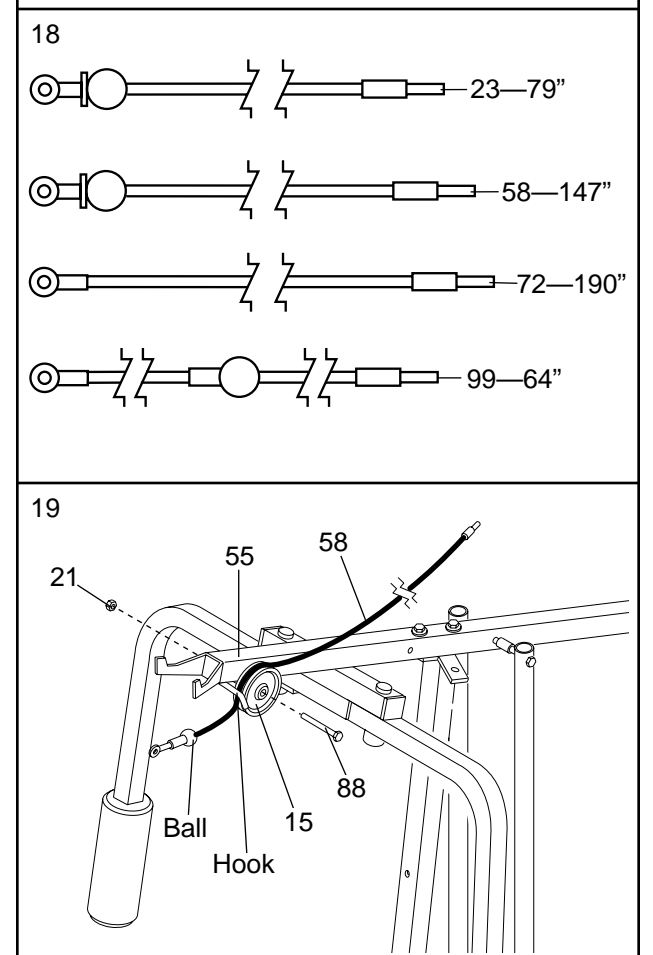

20. Wrap the High Cable (58) around a "V"-Pulley (50). Attach the "V"-Pulley and a Long Cable Trap (31) to the indicated bracket on the Front Upright (42) with a 3/8" x 2 1/2" Bolt (86) and a 3/8" Nylon Locknut (21). **Be sure that the Long Cable Trap is positioned to hold the Cable in place.**

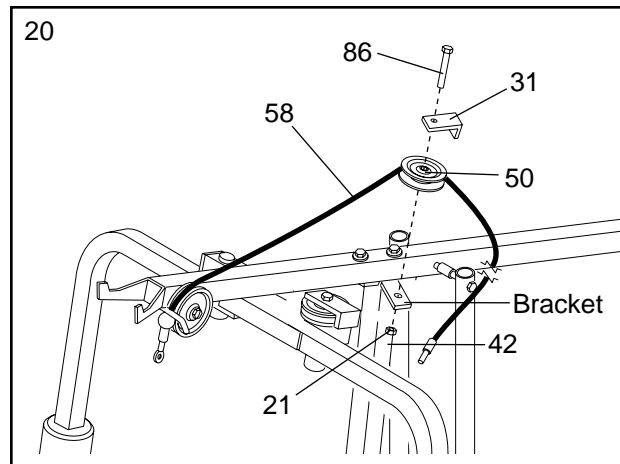

21. Route the High Cable (58) around the "V"-Pulley (50) on the Left Arm (47). **Be sure that the Cable is in the groove of the Pulley and that the Long Cable Trap (31) is positioned to hold the Cable in place.** Tighten the 3/8" x 2 1/2" Bolt (86) and the 3/8" Nylon Locknut (not shown).

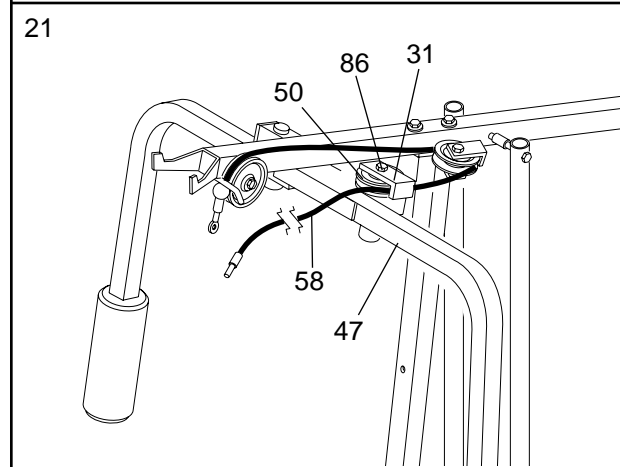

22. Route the High Cable (58) around the "V"-Pulley (50) on the Right Arm (48). **Be sure that the Cable is in the groove of the "V"-Pulley and that the Long Cable Trap (31) is turned to hold the Cable in place.** Tighten the 3/8" x 2 1/2" Bolt (86) and the 3/8" Nylon Locknut (not shown).

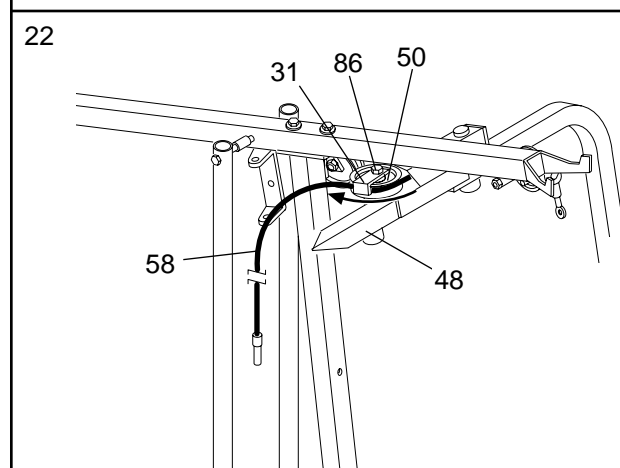

23. Attach the Pulley Bracket (20) to the Top Frame (55) with the 5/16" x 5" Bolt (68) and a 5/16" Nylon Locknut (3). **Do not overtighten the Nylon Locknut; the Pulley Bracket must be able to move freely.**

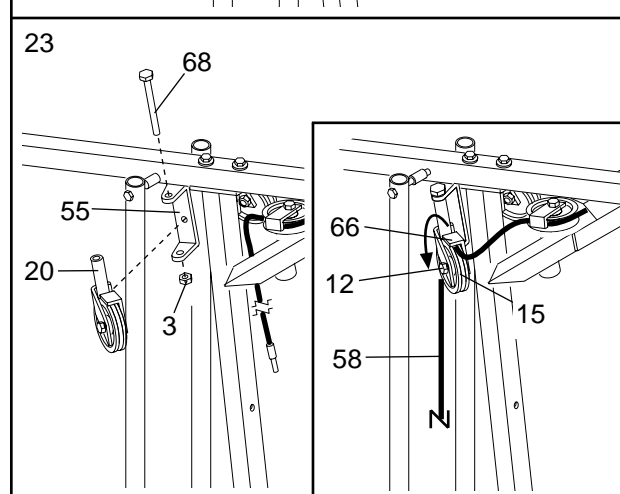

See the inset drawing. Route the High Cable (58) around the 3 1/2" Pulley (15) attached to the Pulley Bracket (20). Tighten the 3/8" x 2" Bolt (12) and a 3/8" Nylon Locknut (not shown). **Be sure that the Cable is in the groove of the Pulley and that the Cable Trap (66) is turned to hold the Cable in place.**

36. Slide a 5/16" Flat Washer (8) onto a 5/16" x 2 3/4" Bolt (11). Insert the Bolt through the indicated hole in the Pivot Arm (101). **The Bolt must be inserted from the side shown.** Fully tighten a 5/16" Nylon Jam Nut (93) onto the Bolt.

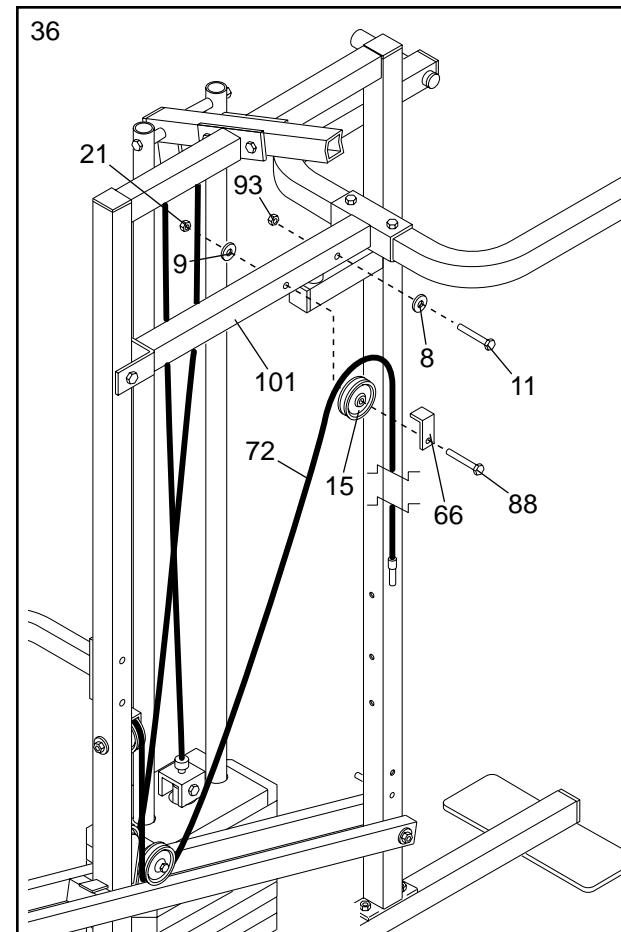

Wrap the Military Press Cable (72) around a 3 1/2" Pulley (15). Attach the Pulley and a Cable Trap (66) to the Pivot Arm (101) with the 3/8" x 3 3/4" Bolt (88), a 3/8" Flat Washer (9), and a 3/8" Nylon Locknut (21). **Be sure that the Pulley is on the side shown and that the Cable Trap is positioned to hold the Cable in place.**

37. See inset drawing A. Attach a 3 1/2" Pulley (15) and a Cable Trap (66) to the upper hole in a Long "U"-Bracket (57) with a 3/8" x 2" Bolt (12) and a 3/8" Nylon Locknut (21). **Be sure that the Cable Trap is inside the Long "U"-Bracket. (Note: This may come pre-assembled.)**

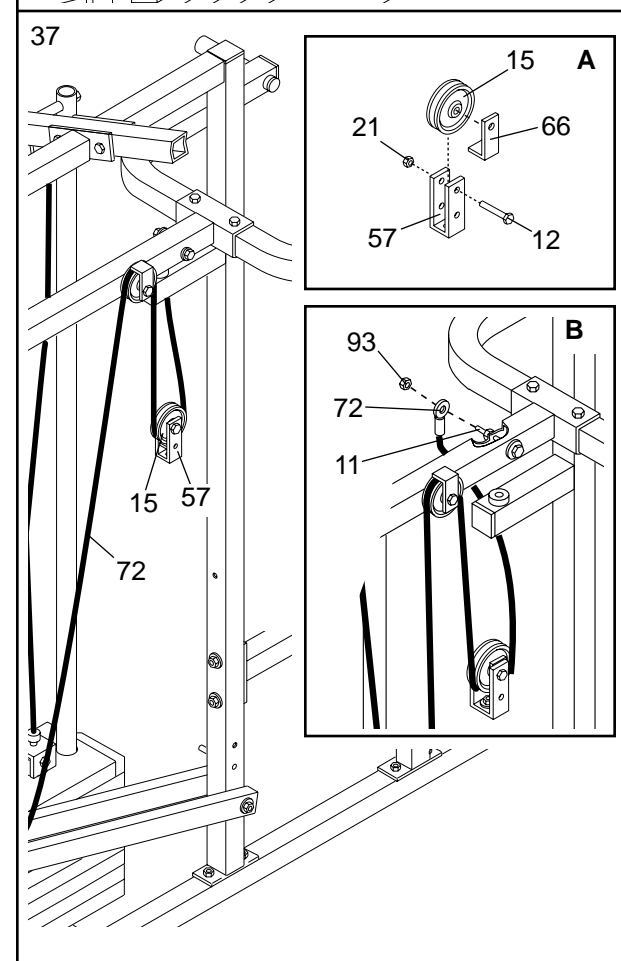

Route the Military Press Cable (72) through the Long "U"-Bracket (57) and the 3 1/2" Pulley (15). **Be sure that the Cable is in the groove of the Pulley and that the Cable and Pulley move smoothly.**

See inset drawing B. Slide the end of the Military Press Cable (72) onto the end of the 5/16" x 2 3/4" Bolt (11). Thread another 5/16" Nylon Jam Nut (93) onto the Bolt. **Do not fully tighten the second Jam Nut. There must be room between the two Jam Nuts for the end of the Cable to pivot.**

34. Wrap the Military Press Cable (72) around a "V"-Pulley (50). Attach the "V"-Pulley to the Top Frame (55) with a 3/8" x 2 1/2" Bolt (86) and a 3/8" Nylon Locknut (21).

Wrap the Military Press Cable (72) around a 3 1/2" Pulley (15). Attach the Pulley to the indicated bracket on the Assist Arm (105) with a 3/8" x 1 3/4" Bolt (76) and a 3/8" Nylon Locknut (21). **Be sure that the Cable is between the Pulley and the Assist Arm and that the Cable and Pulley move smoothly.**

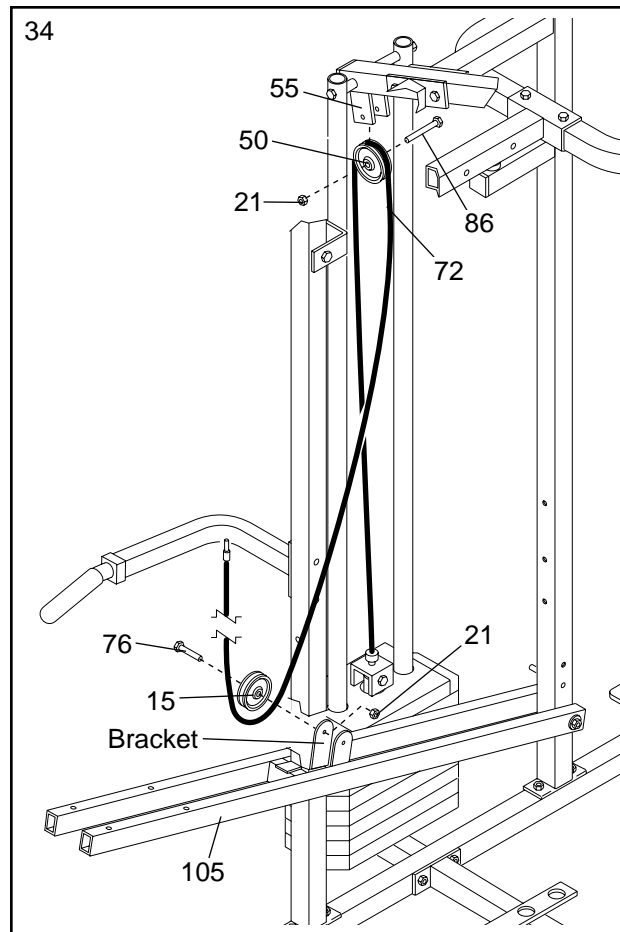

35. Wrap the Military Press Cable (72) around a "V"-Pulley (50). Attach the "V"-Pulley and a Long Cable Trap (31) to the Assist Upright (74) with a 3/8" x 4 1/2" Bolt (112), a 3/8" Flat Washer (9), and a 3/8" Nylon Locknut (21). **Be sure that the Long Cable Trap is turned to hold the Cable in place and that the Cable is routed around the Pulley as shown.**

Wrap the Military Press Cable (72) around a 3 1/2" Pulley (15). Attach the Pulley to the other bracket on the Assist Arm (105) with a 3/8" x 1 3/4" Bolt (76) and a 3/8" Nylon Locknut (21). **Be sure that the Cable is between the Pulley and the Assist Arm and that the Cable and Pulley move smoothly.**

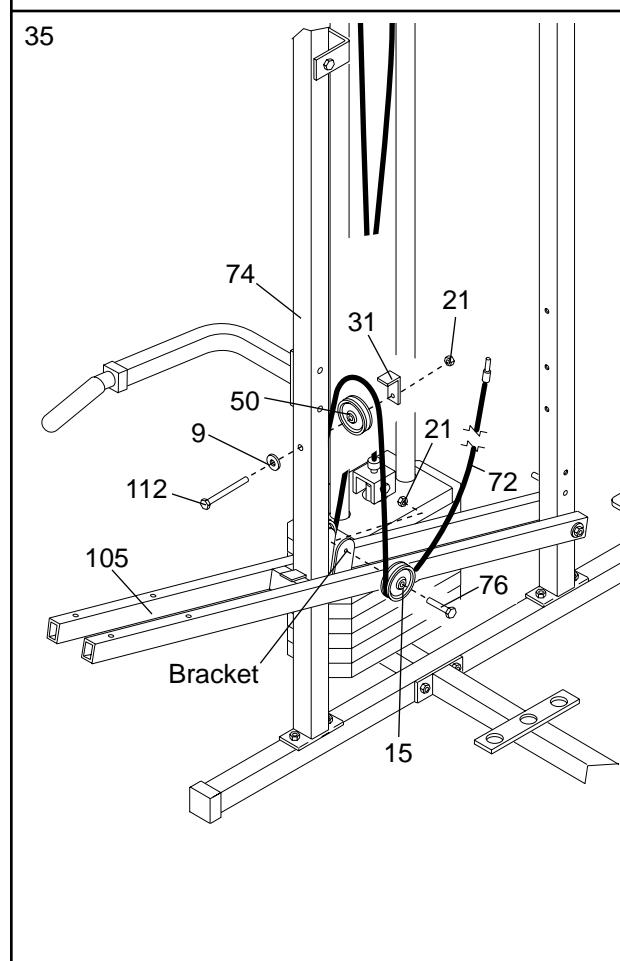

24. See the inset drawing. Attach a 3 1/2" Pulley (15) and a Cable Trap (66) to the upper hole in a Long "U"-Bracket (57) with a 3/8" x 2" Bolt (12) and a 3/8" Nylon Locknut (21). **Be sure that the Cable Trap is inside the Long "U"-Bracket. Note: This may come pre-assembled.**

Route the High Cable (58) through the Long "U"-Bracket (57) and the 3 1/2" Pulley (15) shown in the inset drawing. **Be sure that the Cable is in the groove of the Pulley and that the Cable and Pulley move smoothly.**

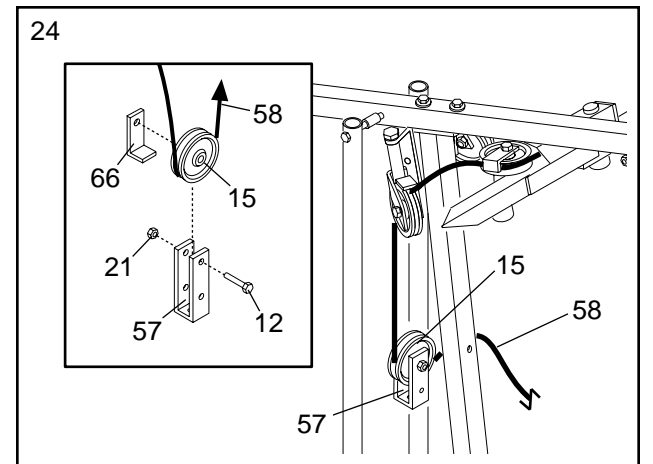

25. Wrap the High Cable (58) around a 3 1/2" Pulley (15). Attach the Pulley to the bracket on the Top Frame (55) with a 3/8" x 2" Bolt (12) and a 3/8" Nylon Locknut (21). **Be sure that the Cable is in the groove of the Pulley and that the Cable and Pulley move smoothly.**

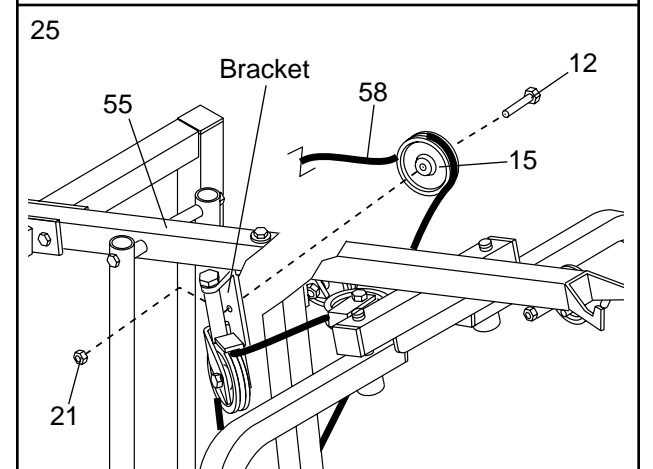

26. **Note: This assembly step shows how to complete the assembly of several pre-attached parts.**

The 5/8" x 9/16" Spacer (7) has been pre-attached on the outside of the 3 1/2" Low Pulley (102) for shipping purposes. Remove the 3/8" Nylon Locknut (21), the Spacer, and the Pulley from the 3/8" x 3 3/4" Bolt (88). **Do not remove the Bolt. The Bolt has been shown removed for part identification.**

Reattach the 3 1/2" Low Pulley (102), with the 5/8" x 9/16" Spacer (7) between the Pulley and the Press Frame (17). **Do not tighten the 3/8" Nylon Locknut (21) yet. Be sure that the 3/8" x 3 3/4" Bolt (88), the 3/8" Flat Washer (9), the 5/8" x 9/16" Spacer (7), the 3 1/2" Low Pulley (102), and the 3/8" Nylon Locknut (21) are oriented as shown.**

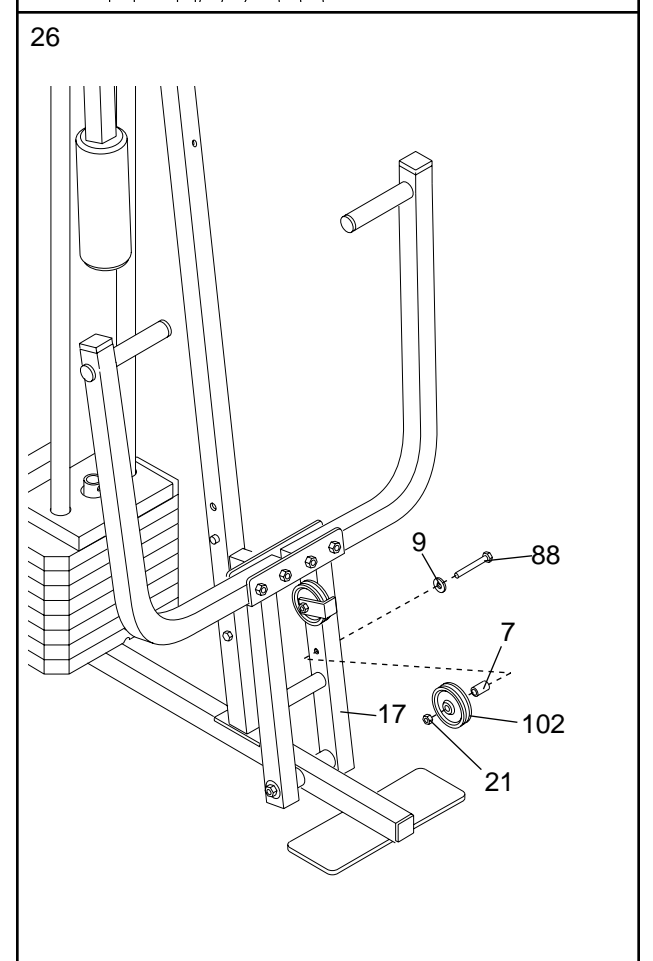

27. **Locate the Low Cable (23).** Route the Low Cable under the 3 1/2" Low Pulley (102). **Be sure that the end of the Cable with the ball is on the indicated side of the Press Frame (17) and that the Cable is between the Pulley and the crossbar on the Press Frame.** Tighten the 3/8" Nylon Locknut (21) and the 3/8" x 3 3/4" Bolt (not shown).

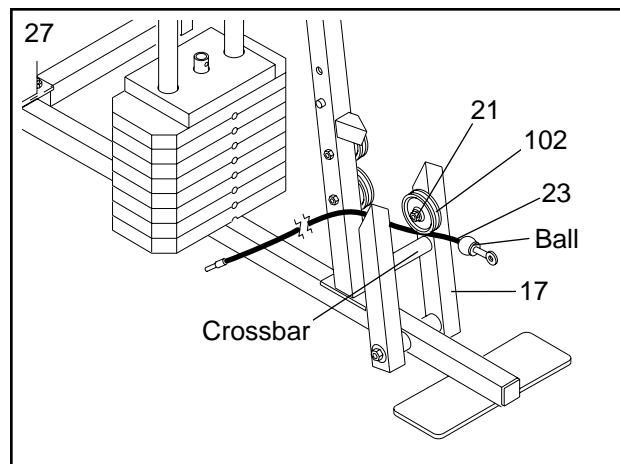

28. Route the Low Cable (23) around the 3 1/2" Pulley (15) attached to the lower hole in the Front Upright (42). **See the inset drawing. Be sure that the Cable Trap (66) is turned to hold the Cable in place and that the Cable is routed around the Pulley as shown.** Tighten the 3/8" Nylon Locknut (21) and the 3/8" x 3 3/4" Bolt (88).

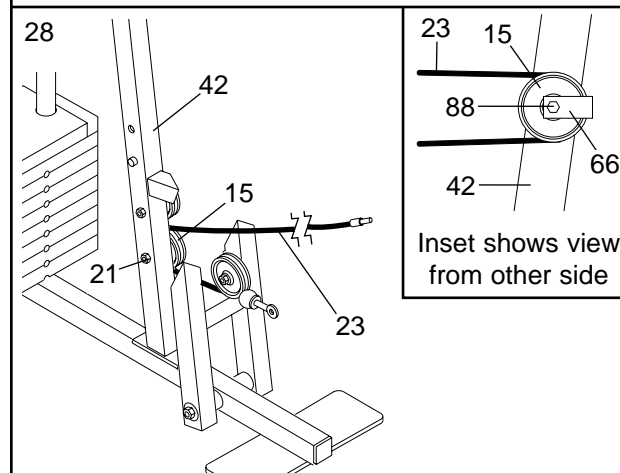

29. Route the Low Cable (23) around the 3 1/2" Pulley (15) attached to the upper hole in the Press Frame (17). **Be sure that the Cable Trap (66) is turned to hold the Cable in place and that the Cable is routed around the Pulley as shown.** Tighten the 3/8" Nylon Locknut (21) and the 3/8" x 3 1/2" Bolt (not shown).

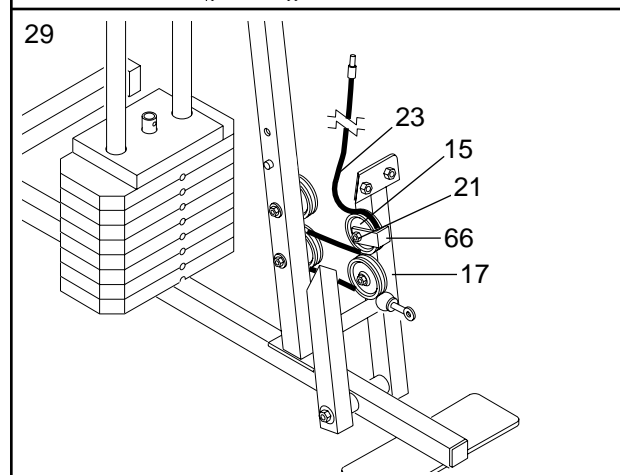

30. Route the Low Cable (23) around the 3 1/2" Pulley (15) attached to the upper hole in the Front Upright (42). **See the inset drawing. Be sure that the Cable Trap (66) is turned to hold the Cable in place and that the Cable is routed around the Pulley as shown.** Tighten the 3/8" Nylon Locknut (21) and the 3/8" x 3 3/4" Bolt (88).

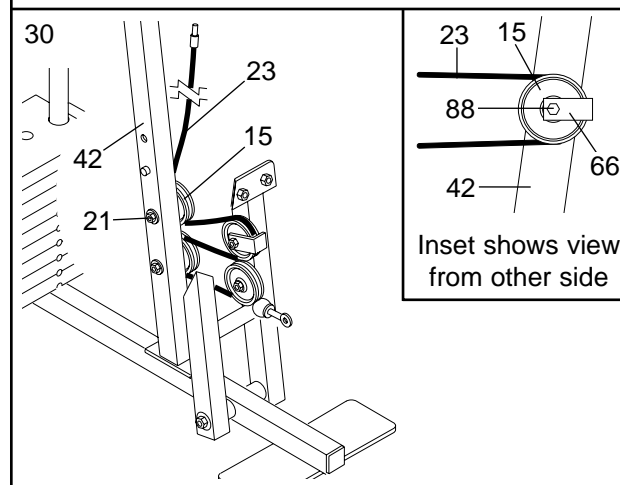

31. Attach the end of the Low Cable (23) to the Long "U"-Bracket (57) with a 1/4" Nylon Locknut (2) and a 1/4" Flat Washer (10). **Do not completely tighten the Nylon Locknut. It should be threaded onto the end of the Cable so only a couple of threads are showing above the Nylon Locknut, as shown in the inset drawing.**

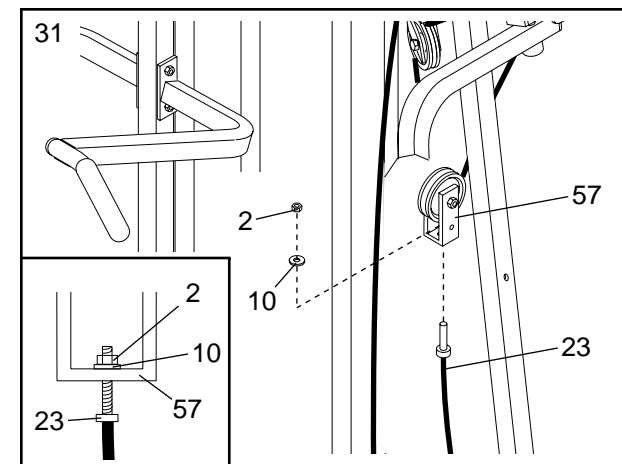

32. Attach the High Cable (58) to a Small "U"-Bracket (71) with a 1/4" Nylon Locknut (2) and a 1/4" Flat Washer (10). **Do not completely tighten the Nylon Locknut. It should be threaded onto the end of the Cable only a couple of turns, as shown in the inset drawing.**

Attach the Small "U"-Bracket (71) to the Short Weight Tube (108) with a 5/16" x 1 3/4" Bolt (24) and a 5/16" Nylon Locknut (3).

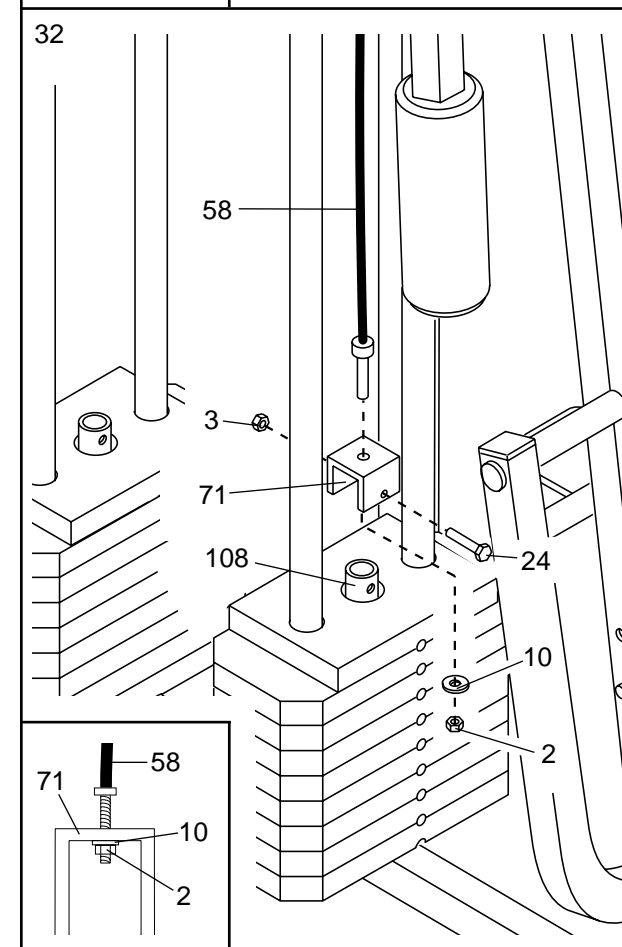

33. **Locate the Military Press Cable (72).** Attach the Military Press Cable to the other Small "U"-Bracket (71) with a 1/4" Nylon Locknut (2) and a 1/4" Flat Washer (10). **Do not completely tighten the Nylon Locknut. It should be threaded onto the end of the Cable only a couple of turns, as shown in the inset drawing.**

Attach the Small "U"-Bracket (71) to the Long Weight Tube (63) with a 5/16" x 1 3/4" Bolt (24) and a 5/16" Nylon Locknut (3).

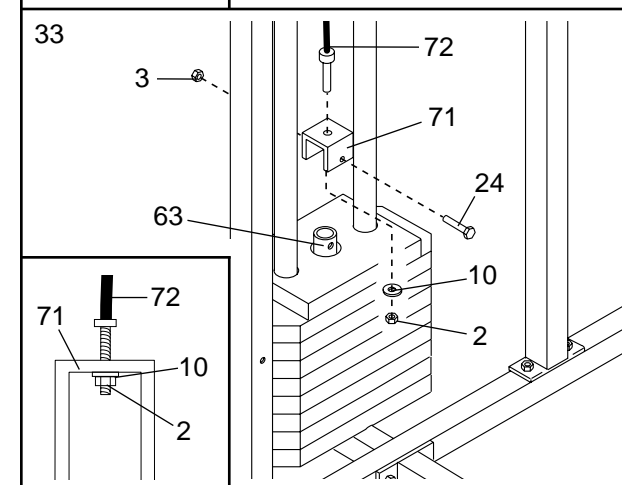

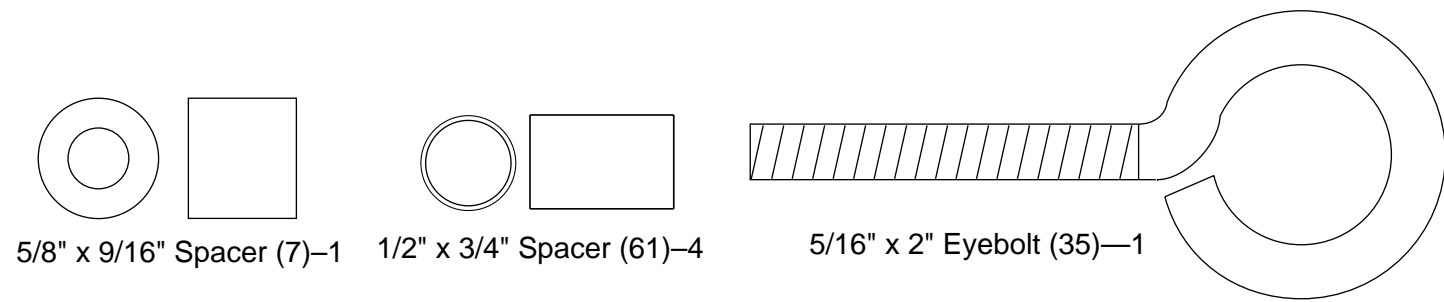

5/8" x 9/16" Spacer (7)–1

1/2" x 3/4" Spacer (61)–4

5/16" x 2" Eyebolt (35)–1

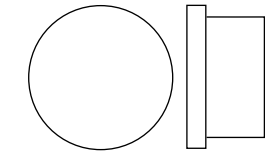

3/4" Round Inner Cap (34)–4

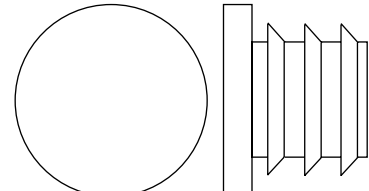

1" Round Inner Cap (49)–6

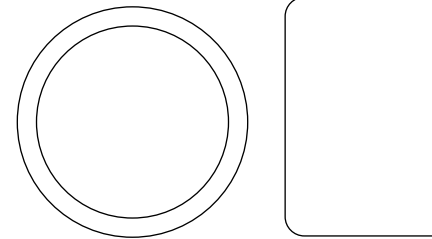

1" Round Cover Cap (70)–2

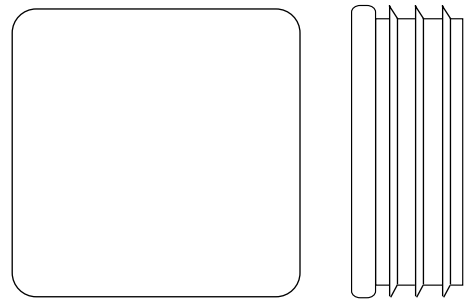

1 1/2" Square Inner Cap (32)–4

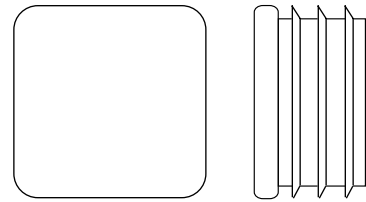

1" Square Inner Cap (6)–1

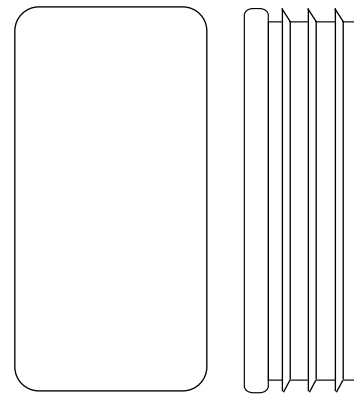

1" x 2" Inner Cap (107)–2

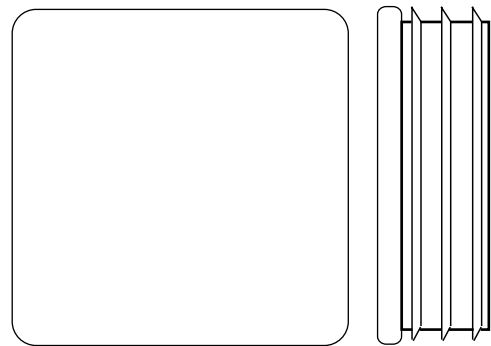

1 3/4" Square Inner Cap (44)–6

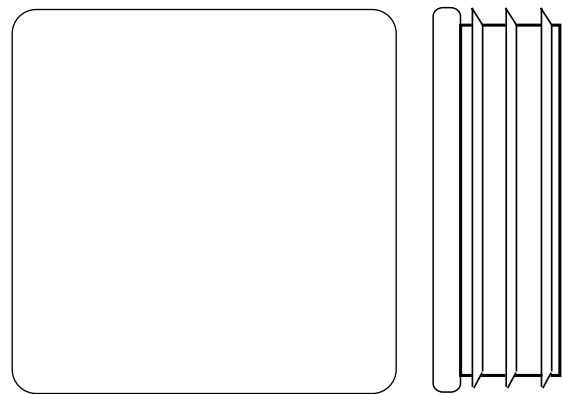

2" Square Inner Cap (27)–8



2" Square Outer Cap (51)–2

REMOVE THIS PART IDENTIFICATION CHART FROM THE MANUAL

This chart is provided to help you identify the small parts used in assembly. **Important: Some parts may have been pre-assembled for shipping purposes. If you cannot find a part in the parts bags, check to see if it has been pre-assembled.** The number in parenthesis below each part refers to the key number of the part. The second number refers to the quantity needed for assembly.

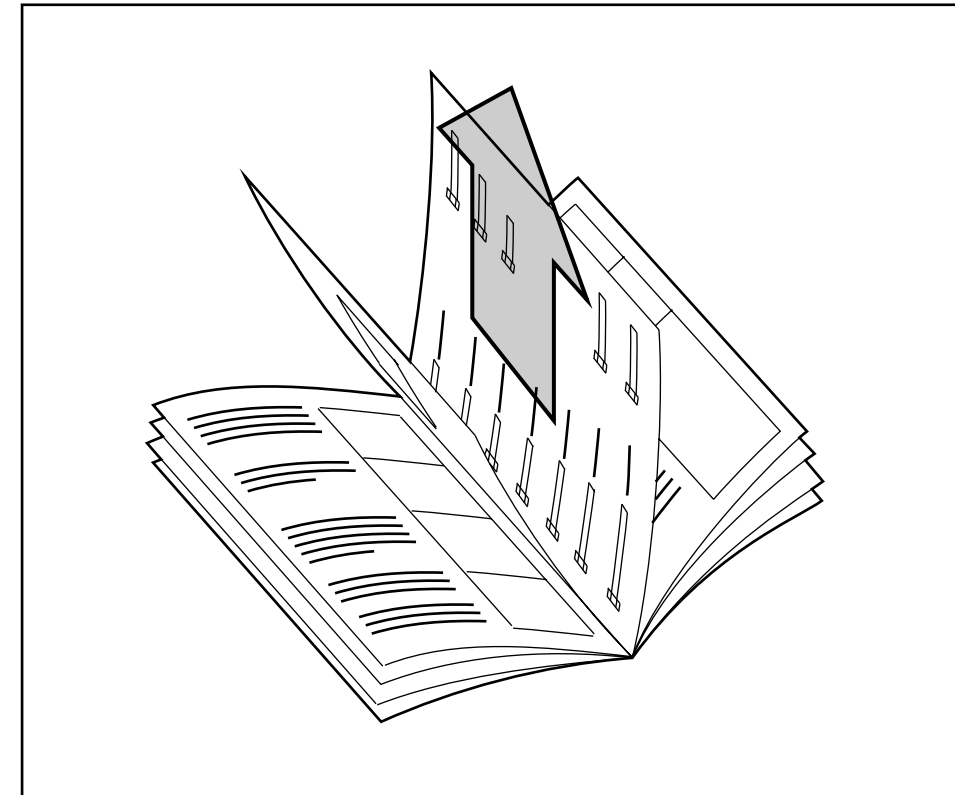

Please Note: The assembly is divided into four stages: 1) frame assembly, 2) arm assembly, 3) cable and pulley assembly, and 4) seat and backrest assembly. The hardware for each stage is packaged separately. WAIT UNTIL YOU BEGIN EACH ASSEMBLY STAGE TO OPEN THE PARTS BAG LABELLED FOR THAT ASSEMBLY STAGE.

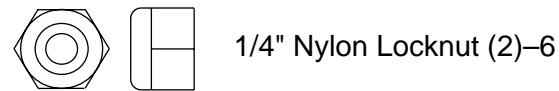

1/4" Nylon Locknut (2)-6

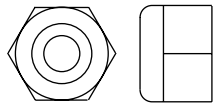

5/16" Nylon Locknut (3)-36

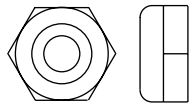

5/16" Nylon Jam Nut (93)-4

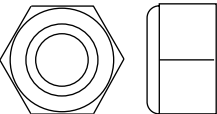

3/8" Nylon Locknut (21)-23

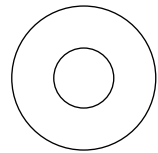

1/4" Flat Washer (10)-15

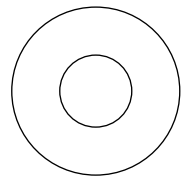

5/16" Flat Washer (8)-9

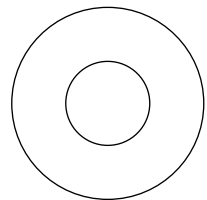

3/8" Flat Washer (9)-9

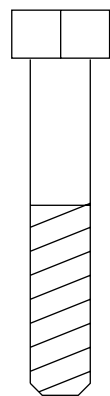

5/16" x 1 3/4" Bolt (24)-2

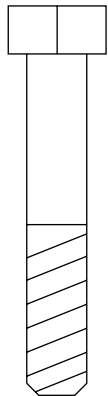

3/8" x 1 3/4" Bolt (76)-2

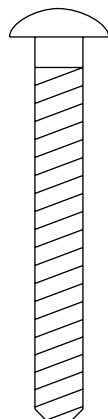

1/4" x 2" Carriage Bolt (38)-1

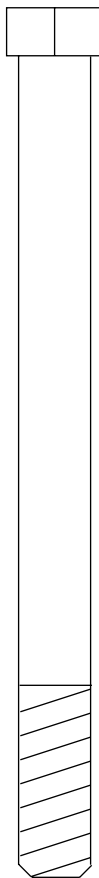

3/8" x 4 1/2" Bolt (112)-1

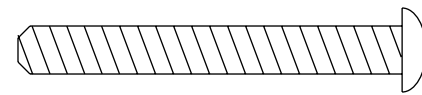

1/4" x 2" Machine Screw (81)-1

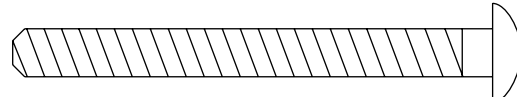

1/4" x 2 1/2" Carriage Bolt (92)-1

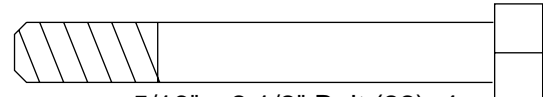

5/16" x 2 1/2" Bolt (22)-4

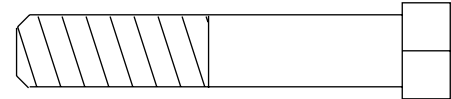

3/8" x 2" Bolt (12)-5



5/16" x 2 1/4" Bolt (33)-3

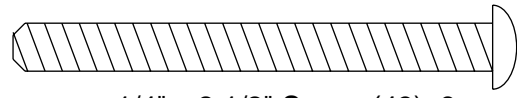

1/4" x 2 1/2" Screw (43)-8



5/16" x 2 1/2" Carriage Bolt (1)-10

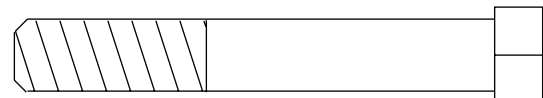

3/8" x 2 1/2" Bolt (86)-4

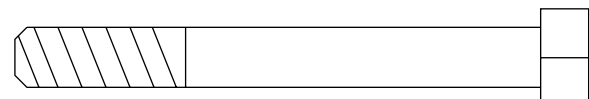

5/16" x 2 3/4" Bolt (11)-14

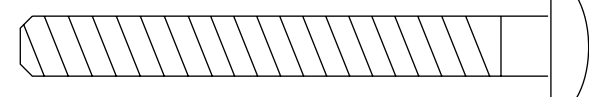

5/16" x 2 3/4" Carriage Bolt (14)-1



3/8" x 3 1/4" Bolt (67)-2

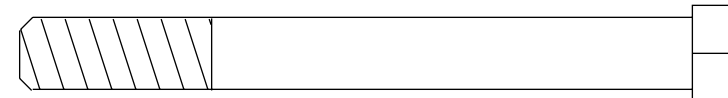

3/8" x 3 1/2" Bolt (16)-1

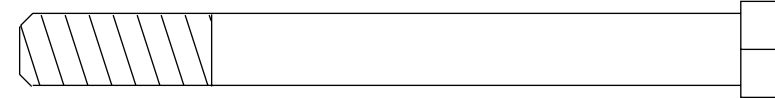

3/8" x 3 3/4" Bolt (88)-6

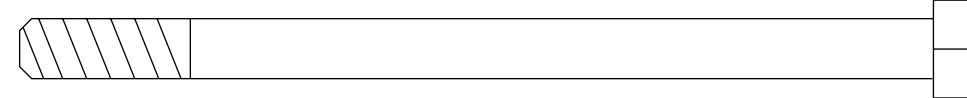

5/16" x 5" Bolt (68)-1



5/16" x 3" Bolt (111)-1

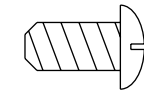

1/4" x 1/2" Screw (18)-6

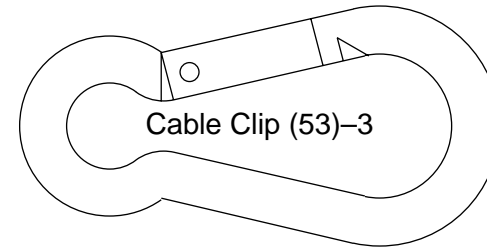

Cable Clip (53)-3

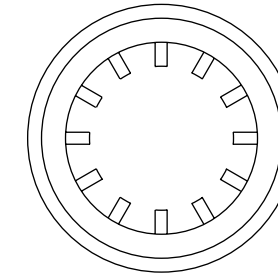

1" Retainer (69)-4

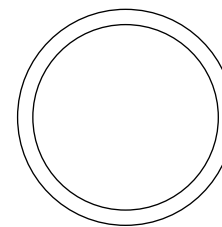

1 1/8" x 2 1/2" Plastic Bushing (89)-2

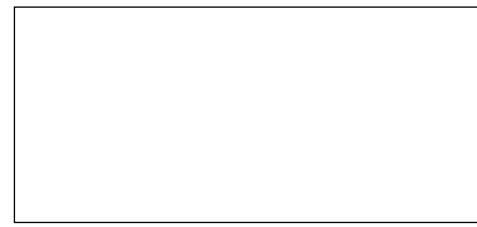

1" x 7/8" Plastic Bushing (90)-2

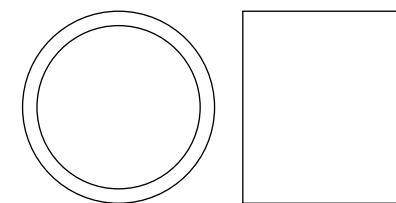

3 1/2" Pulley (15)-13
(Not shown to scale)

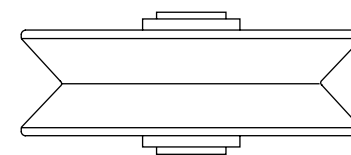

"V"-Pulley (50)-5
(Not shown to scale)

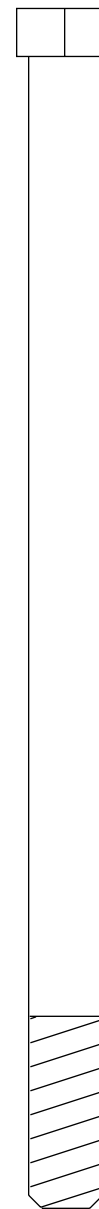

3/8" x 6" Bolt (106)-1

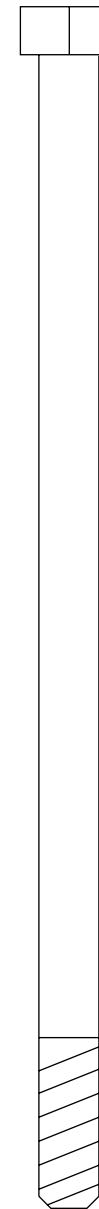

5/16" x 6" Bolt (60)-2

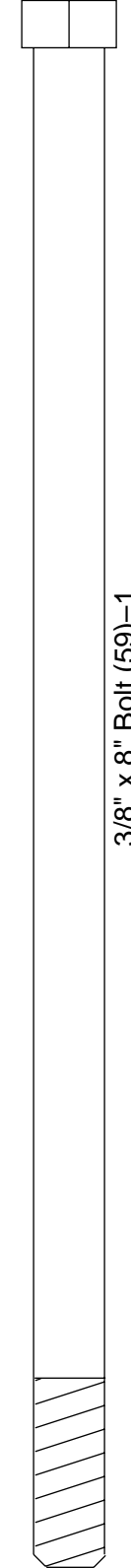

3/8" x 8" Bolt (59)-1

PART LIST—Model No. WESY96450

R0996A

Key No.	Qty.	Description	Key No.	Qty.	Description
1	10	5/16" x 2 1/2" Carriage Bolt	58	1	High Cable
2	6	1/4" Nylon Locknut	59	1	3/8" x 8" Bolt
3	36	5/16" Nylon Locknut	60	2	5/16" x 6" Bolt
4	1	Base	61	4	1/2" x 3/4" Spacer
5	1	Stabiliser	62	2	Long Weight Guide
6	1	1" Square Inner Cap	63	1	Long Weight Tube
7	1	5/8" x 9/16" Spacer	64	2	Weight Tube Bumper
8	9	5/16" Flat Washer	65	2	Top Weight
9	9	3/8" Flat Washer	66	7	Cable Trap
10	15	1/4" Flat Washer	67	2	3/8" x 3 1/4" Bolt
11	14	5/16" x 2 3/4" Bolt	68	1	5/16" x 5" Bolt
12	5	3/8" x 2" Bolt	69	4	1" Retainer
13	2	Seat	70	2	1" Round Cover Cap
14	1	5/16" x 2 3/4" Carriage Bolt	71	2	Small "U"-Bracket
15	13	3 1/2" Pulley	72	1	Military Press Cable
16	1	3/8" x 3 1/2" Bolt	73	2	Short Weight Guide
17	1	Press Frame	74	1	Assist Upright
18	6	1/4" x 1/2" Screw	75	1	Left Pull-up Arm
19	4	Weight Bumper	76	2	3/8" x 1 3/4" Bolt
20	1	Pulley Bracket	77	1	Right Pull-up Arm
21	23	3/8" Nylon Locknut	78	1	Left Dip Arm
22	4	5/16" x 2 1/2" Bolt	79	1	Right Dip Arm
23	1	Low Cable	80	2	Long Handgrip
24	2	5/16" x 1 3/4" Bolt	81	1	1/4" x 2" Machine Screw
25	18	Weight	82	1	Handle
26	2	Weight Pin	83	8	5" Plastic Handgrip
27	8	2" Square Inner Cap	84	1	Military Press Arm
28	2	Pad Tube	85	1	Rear Backrest
29	1	Leg Lever	86	4	3/8" x 2 1/2" Bolt
30	4	Foam Pad	87	1	#8 x 1/2" Self-tapping Screw
31	4	Long Cable Trap	88	6	3/8" x 3 3/4" Bolt
32	4	1 1/2" Square Inner Cap	89	2	1 1/8" x 2 1/2" Plastic Bushing
33	3	5/16" x 2 1/4" Bolt	90	2	1" x 7/8" Plastic Bushing
34	4	3/4" Round Inner Cap	91	1	Rubber Bumper
35	1	5/16" x 2" Eyebolt	92	1	1/4" x 2 1/2" Carriage Bolt
36	1	Front Seat Frame	93	4	5/16" Nylon Jam Nut
37	2	Seat Plate	94	1	Press Bracket
38	1	1/4" x 2" Carriage Bolt	95	1	Leg Press Plate
39	1	Nylon Strap	96	1	Leg Press Arm
40	1	Seat Knob	97	1	Press Pin
41	1	Front Backrest	98	2	Bushing
42	1	Front Upright	99	1	Leg Press Cable
43	8	1/4" x 2 1/2" Screw	100	1	Rear Seat Frame
44	6	1 3/4" Square Inner Cap	101	1	Pivot Arm
45	2	10" Pad	102	1	3 1/2" Low Pulley
46	2	Press Arm	103	2	Handle Cap
47	1	Left Arm	104	1	Assist Seat
48	1	Right Arm	105	1	Assist Arm
49	6	1" Round Inner Cap	106	1	3/8" x 6" Bolt
50	5	"V"-Pulley	107	2	1" x 2" Inner Cap
51	2	2" Square Outer Cap	108	1	Short Weight Tube
52	1	Chain	109	6	1 1/4" Round Inner Cap
53	3	Cable Clip	110	1	Angle Bracket
54	1	Lat Bar	111	1	5/16" x 3" Bolt
55	1	Top Frame	112	1	3/8" x 4 1/2" Bolt
56	1	Leg Press Upright	113	2	Short Handgrip
57	2	Long "U"-Bracket	#	1	User's Manual

REMOVE THIS PART LIST/EXPLODED DRAWING CHART FROM THE MANUAL

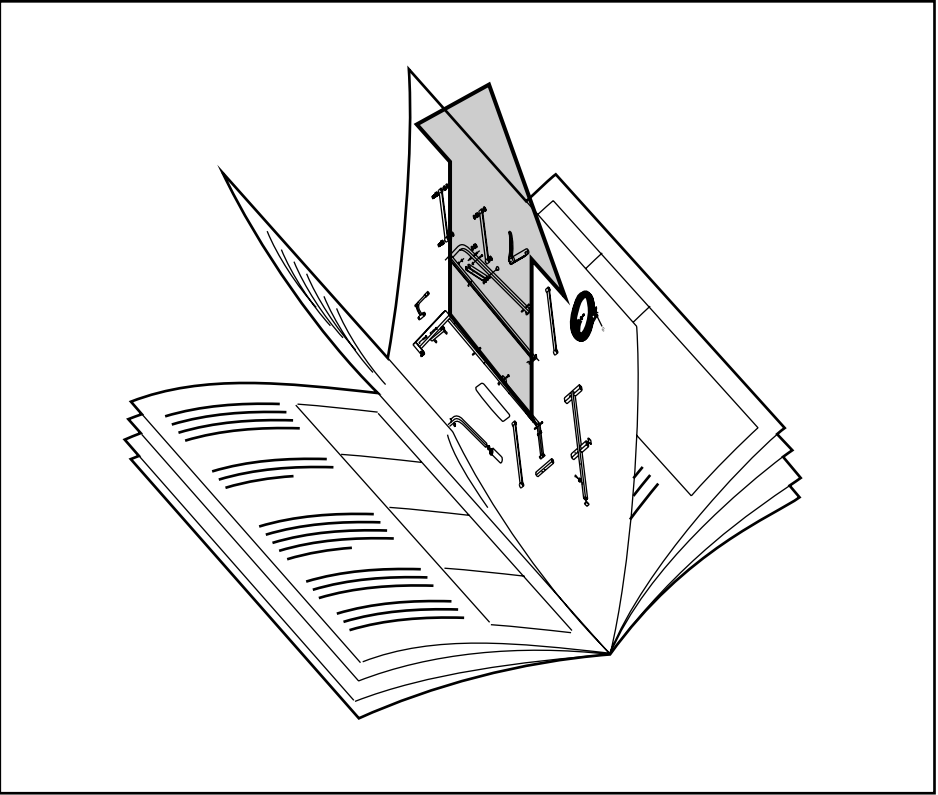

Note: "#" indicates a non-illustrated part. Specifications are subject to change without notice.

EXPLODED DRAWING—Model No. WESY96450

R0996A

