



**NETWORK
TECHNOLOGIES
INCORPORATED**

1275 Danner Dr Tel:330-562-7070
Aurora, OH 44202 Fax:330-562-1999
www.networktechinc.com

VEEMUX[®] Series

SM-nXm-DVI(A)-LCD

DVI Video Matrix Switch

Installation and Operation Manual



TRADEMARK

VEEMUX is a registered trademark of Network Technologies Inc in the U.S. and other countries.

COPYRIGHT

Copyright © 2010, 2013 by Network Technologies Inc. All rights reserved. No part of this publication may be reproduced, stored in a retrieval system, or transmitted, in any form or by any means, electronic, mechanical, photocopying, recording, or otherwise, without the prior written consent of Network Technologies Inc, 1275 Danner Drive, Aurora, Ohio 44202.

CHANGES

The material in this guide is for information only and is subject to change without notice. Network Technologies Inc reserves the right to make changes in the product design without reservation and without notification to its users.

FIRMWARE VERSION

Current Firmware version 2.4 (4x4,16x16 and 32x32 models)
version 1.7 (8x8 models)

TABLE OF CONTENTS

Introduction	1
Supported Web Browsers.....	1
Materials	2
Features and Functions	3
Installation	4
To Mount to a Rack.....	4
Make All Connections.....	5
Audio Connections.....	8
Operating the VEEMUX	9
Front Panel LCD with Keypad Control.....	9
LCD Menus.....	10
Save and Load (Recall) Config.....	12
USB Console Port.....	13
Installing Drivers.....	13
Windows XP-32 bit Installation.....	13
Windows 7-64 bit Installation.....	15
Using the USB Console Port.....	17
RS232 Control	18
Remote Connection.....	18
Baud Rate.....	18
Unit Address and Loop Back.....	18
Command Protocol.....	20
Autostatus.....	21
Matrix Switcher's Control Program For Windows 9X, NT, 2000, XP, Vista and 7.....	21
SerTest- RS232 Interface Test Program.....	22
Main Options.....	22
Matrix Operations.....	22
Ethernet Operations.....	22
Setup Options.....	23
Ethernet Control	24
Telnet Interface-Port 2000.....	24
Telnet Interface-Port 2005.....	26
Command Summary.....	26
Command Detail.....	27
RU-Read Unit Size.....	27
RO-Read Connection for Output Port.....	27
CS- Connect Output Port to Input Port.....	27
CA- Connect All Output Ports to Input Port.....	27
SS_01- Enable Auto Status Mode.....	28
SS_00- Disable Auto Status Mode.....	28
SX- Examine connections.....	28
AO-Read Audio Connection for Output Port.....	29
AS-Connect Audio Output Port to Input Port.....	29
AA-Connect All Audio Outputs to Input Port.....	29
AV- Set Audio Volume for Output Port.....	30
AM- Mute/Unmute Audio Output Port.....	30
Terminate telnet session.....	30
Web Interface.....	31
Enter the Password.....	31
Main Menu.....	32
Video Switch Page.....	33
Administration.....	34
System Configuration.....	34
Network Configuration.....	35
Video Input Names.....	36
Video Output Names.....	37
Scanning Sequences.....	38
User Config.....	40

DDC Options.....	41
Hot Plug Options	42
DDC Mix	42
Video Optimization	43
Update Firmware	44
Standby Mode	45
Logout.....	45
Support	46
Reboot	46
Web Interface With Audio Support	47
Device Discovery Tool.....	48
Infrared Remote Control.....	49
Materials	49
Buttons.....	50
Operation	51
Changing Ports	51
Channel Surfing.....	51
Jump To Input.....	52
Jump To Output.....	52
Connect All	52
Save and Recall.....	53
Multiple Switch Control	53
Canceling a Command	53
Independent Video and Audio Control.....	53
Technical Specifications For IRT-UNV	54
Troubleshooting the IRT-UNV	54
Troubleshooting the VEEMUX.....	54
General Technical Specifications	55
Index	56
Warranty Information.....	56

TABLE OF FIGURES

Figure 1- Secure rack mount ears to switch.....	4
Figure 2- Secure switch to a rack	4
Figure 3- Connect video sources to VEEMUX	5
Figure 4- Connect display devices to VEEMUX.....	5
Figure 5- Connect RS232 control terminal to VEEMUX.....	6
Figure 6- Connect RS232 using USB cable	6
Figure 7- Connect VEEMUX to local area network	7
Figure 8- Attach AC power cord to VEEMUX.....	7
Figure 9- Connect Audio Source and Speakers.....	8
Figure 10- COM port assigned to VEEMUX.....	17
Figure 11- Configure COM port in Matrix Switcher's Control Program.....	17
Figure 12- RS232 connection with Matrix-Y-1 cable.....	19
Figure 13- Pinout of Matrix-Y-1 cable	19
Figure 14- Web interface Login page.....	31
Figure 15- Administrator Menu	32
Figure 16- Main menu and Video Switch page	32
Figure 17- System Configuration page	34
Figure 18- Network Configuration page	35
Figure 19- Video Input Names page	36
Figure 20- Video Output Names page	37
Figure 21- Scanning Sequence page	38
Figure 22- Users page	40
Figure 23- User configuration page	40
Figure 24- DDC Options page	41
Figure 25- DDC Mix page	42
Figure 26- Video Optimization page	43
Figure 27- Update Firmware page	44
Figure 28- VEEMUX in Standby Mode.....	45
Figure 29- Logout of the VEEMUX web interface	45
Figure 30- Support Tab.....	46
Figure 31- System Reboot.....	46
Figure 32- Audio Switch page.....	47
Figure 33- Device Discovery Tool page.....	48

INTRODUCTION

The VEEMUX DVI Video Matrix switch (VEEMUX) provides non-blocking access to 4, 8, 16, or 32 single link digital DVI video sources from 4, 8, 16, or 32 displays. Locate computers up to 19 feet away from displays, enabling easy access to multiple servers in various locations. The “*n*” in the part number SM-*nXm*-DVI-LCD represents the number of displays. The “*m*” in the part number represents the number of video sources.

Option:

Audio Support- For a switch with support for self-powered stereo audio, add an “A” to the model number (i.e. SM-8X8-DVIA-LCD).

Models available:

SM-4X4-DVI-LCD	SM-4X4-DVIA-LCD
SM-8X8-DVI-LCD	SM-8X8-DVIA-LCD
SM-16X16-DVI-LCD	SM-16X16-DVIA-LCD
SM-32X32-DVI-LCD	SM-32X32-DVIA-LCD

Features:

- Configure and control the switch through serial port, front panel buttons, web interface, or optional infrared control.
- Supports DVI-D interface for crisp and clear video quality on flat panel displays.
- Supports DVI operation at the maximum TMDS rate of 1.65 Gb/second
- Silent fanless operation.
- Provides high digital resolution up to 1920x1200 for monitors and 1080p for HDTV displays.
- EDID learning for the support of any DVI display device.
- Built in default EDID configuration tables for both PC and Mac.
 - Dual default EDID configuration tables: high resolution without audio and TV resolution with audio.
- Each output provides one video signal.
- Each input can be independently connected to any or all outputs.
- Video quality can be optimized between each input and output.
- Up to 16 users (including “root”) can be configured to control the VEEMUX from the Web Interface

Supported Web Browsers

Most modern web browsers should be supported. The following browsers have been tested:

- Microsoft Internet Explorer 6.0 or higher
- Netscape 7.0 or higher
- Mozilla FireFox 3.5.8 or higher
- Google Chrome 9.0.5 or higher
- Apple Safari 5.0.3 or higher
- Opera 11.0 or higher

Set your browser to always check if there is a newer version of the page than the version stored in cache. This action will ensure that it will display the most up-to-date information.

MATERIALS

Materials supplied with this kit:

- NTI SM-nXm-DVI-LCD DVI Video Matrix Switch
- Power Cord- country specific
- IRT-UNV Remote Control
- CT6182 DB9 Female-to-RJ45 Female adapter
- CB4352- 5 foot CAT5 patch cable
- Rack mount kit (2 Mounting ears (MP3180-4X4; MP4041-8X8), 6 screws-HW6137) (4X4 and 8X8 only)
- 4pcs #10-32 x 3/4" pan head screws and #10-32 cage nuts (server cabinet mounting hardware)
- CD containing pdf of this manual and control software
- zip ties (10 pcs-4X4; 20 pcs- 8X8; 36 pcs- 16X16; 66 pcs- 32X32)
- 4 pcs rubber feet (CS4028) (4X4 and 8X8 only)

Materials Not supplied but *REQUIRED*:

- DVI-IS-xx-MM cable for each monitor and CPU being connected to the switch- available in 3, 6,10, and 15 foot lengths
- DVI-HDMI-xx-MM for HDMI monitor or CPU being connected to the switch- available in 3,6,10, and 15 foot lengths
- SA-xx-MM male-to-male stereo audio cables (for models with audio support)- available in 3,6,10, and 15 foot lengths

where:

xx is the length of the cable in feet

MM indicates male-to-male connector

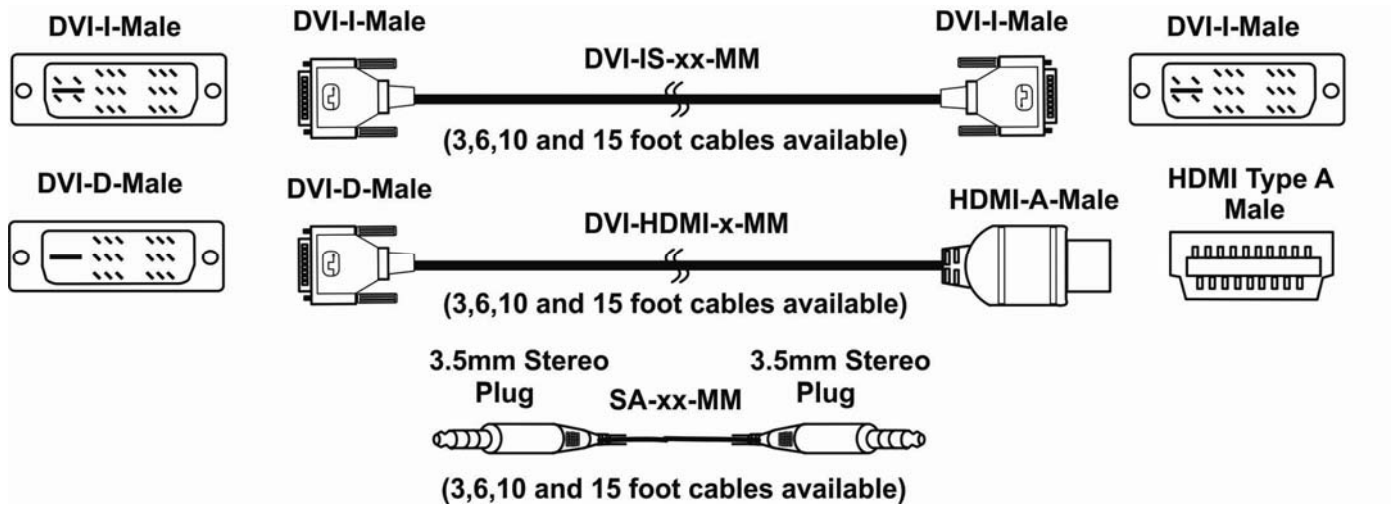

Note: DVI cables longer than 15 feet may provide poor video performance on this product.

FEATURES AND FUNCTIONS

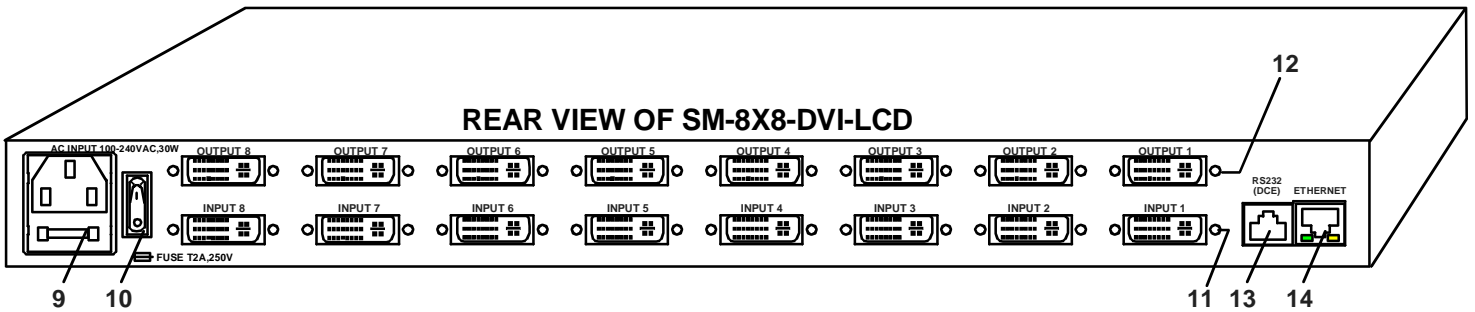
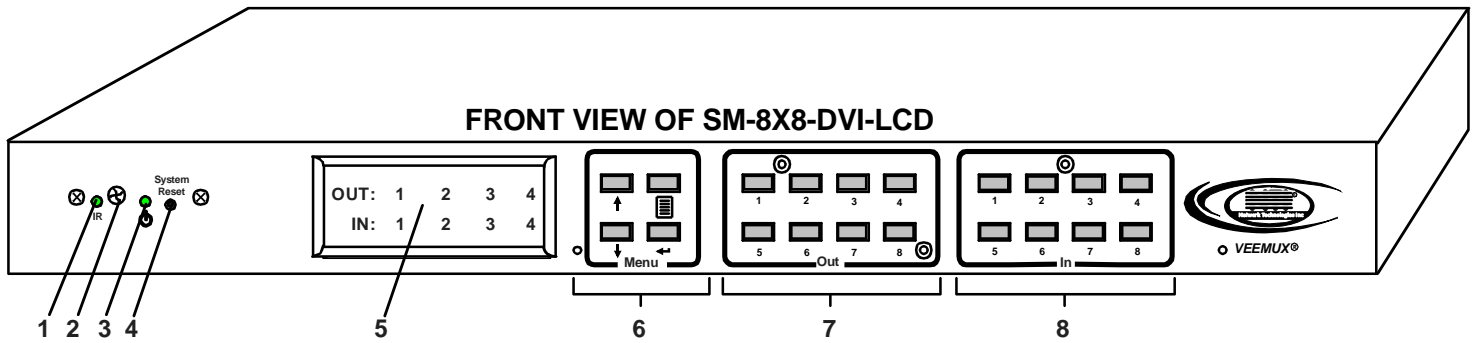

1. **IR LED-** for indicating when an infrared signal is being received from the IR remote control
2. **IR Receiver-** this receives the IR signal from the infrared remote control (optional)
3. **Power/Standby-** this LED indicates when the VEEMUX is either ready for user interface (green) or in standby mode (red)
4. **System Reset-** press this button to cycle the VEEMUX processor and reboot the system
5. **LCD Display-** for indicating what inputs (video sources) are connected to the labeled output (display device)
6. **Menu buttons-** used to control LCD menu navigation
7. **Out buttons-** used to select which outputs (display devices) to connect to which inputs (video sources) when pressed
8. **In buttons-** used to select which inputs (video sources) to connect to which outputs (display devices) when pressed
9. **IEC Connector-** for connection of AC power cord
10. **Power Switch-** for turning the VEEMUX ON or OFF
11. **Input-** DVI-I Female connector- for connecting to DVI/HDMI video sources
12. **Output-** DVI-I Female connector- for connecting to DVI/HDMI display devices
13. **RS232 connector-** RJ45 female- for connecting the user's RS232 control cable
14. **ETHERNET-** RJ45 female connector- for connection of CAT5 cable to Local Area Network (LAN) for WEB interface

INSTALLATION

This NTI switch was designed to be mounted to a rack or to set on a desktop. It includes rack mount ears to make attachment to a rack easy, and rubber feet to be applied to the bottom of the case if it will instead sit on a flat surface. If this will sit on a flat surface, simply apply the rubber feet to the bottom of the case in each of the 4 corners.

To Mount to a Rack

1. (For SM-8X8-DVI-LCD, otherwise skip to step 2) Attach the ears to the switch using the #6-32x3/16" flat Phillips-head screws (6) provided as shown in the illustration below. The holes in the ears should line up with pre-threaded holes in the sides of the NTI switch. Tighten the screws securely.

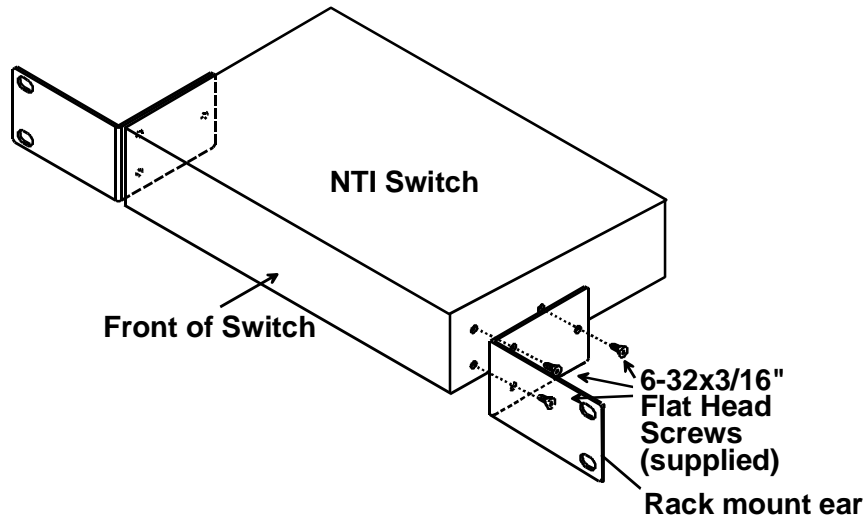

Figure 1- Secure rack mount ears to switch

2. Install 4 cage nuts (supplied) to the rack in locations that line up with the holes in the mounting ear on the NTI switch.
3. Secure the NTI switch to the rack using four #10-32X3/4" screws (supplied). Each screw should be of sufficient length to go completely through the NTI mounting ear, rack frame and fully engage all threads in the cage nut. Be sure to tighten all mounting screws securely.
4. Attach all cables securely to the switch and where necessary supply adequate means of strain relief for cables.

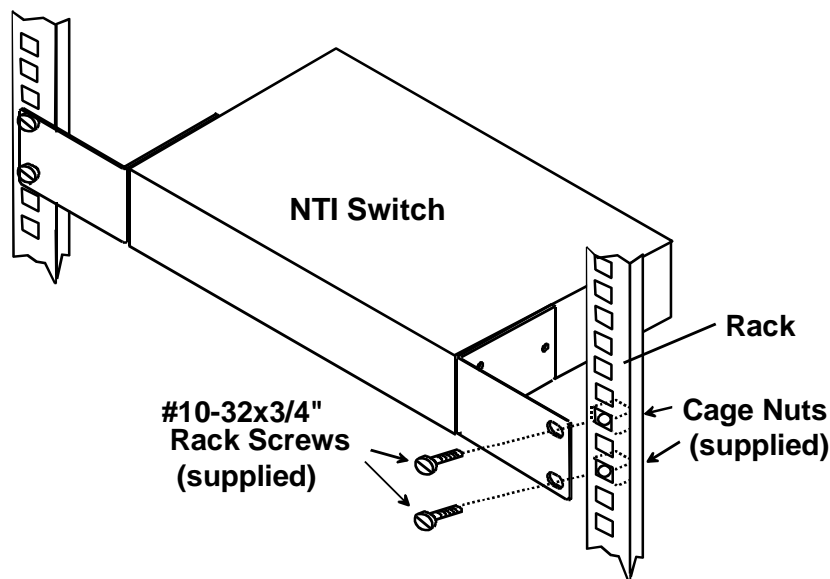

Figure 2- Secure switch to a rack

Make All Connections

1. Connect a DVI male cable (15 feet maximum) between each video source and an "Input" connector on the rear of the VEEMUX.

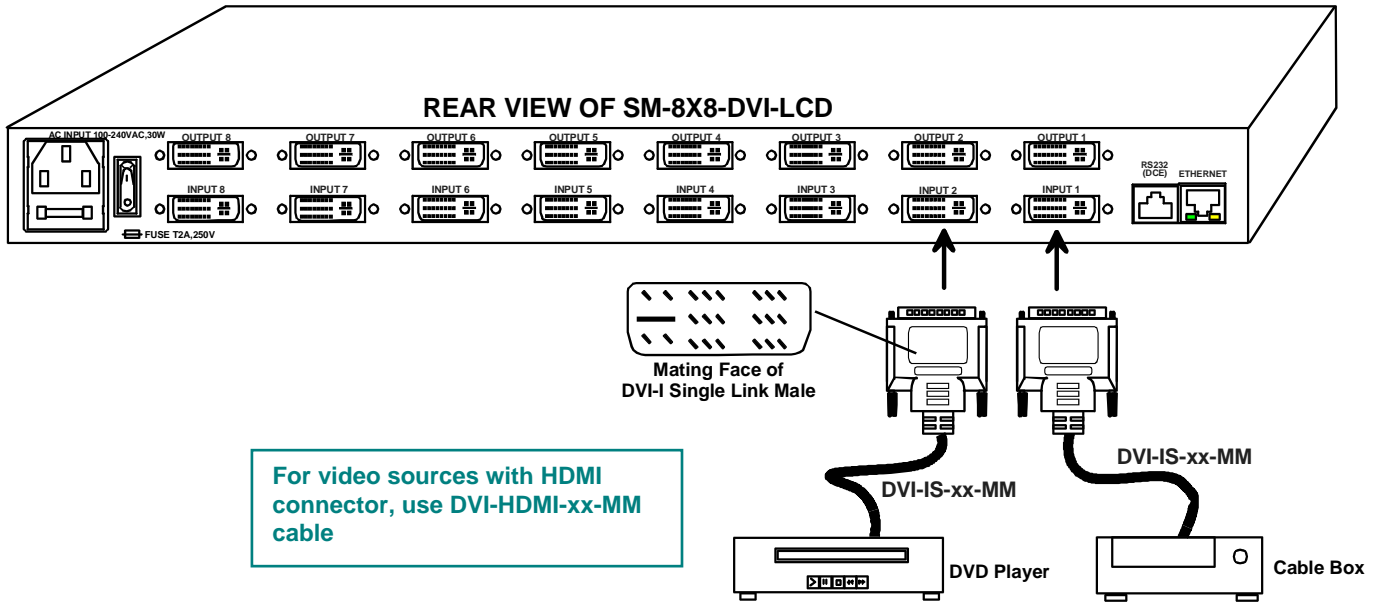

Figure 3- Connect video sources to VEEMUX

2. Connect a DVI male cable (15 feet maximum) between each display device and an "Output" connector on the rear of the VEEMUX.

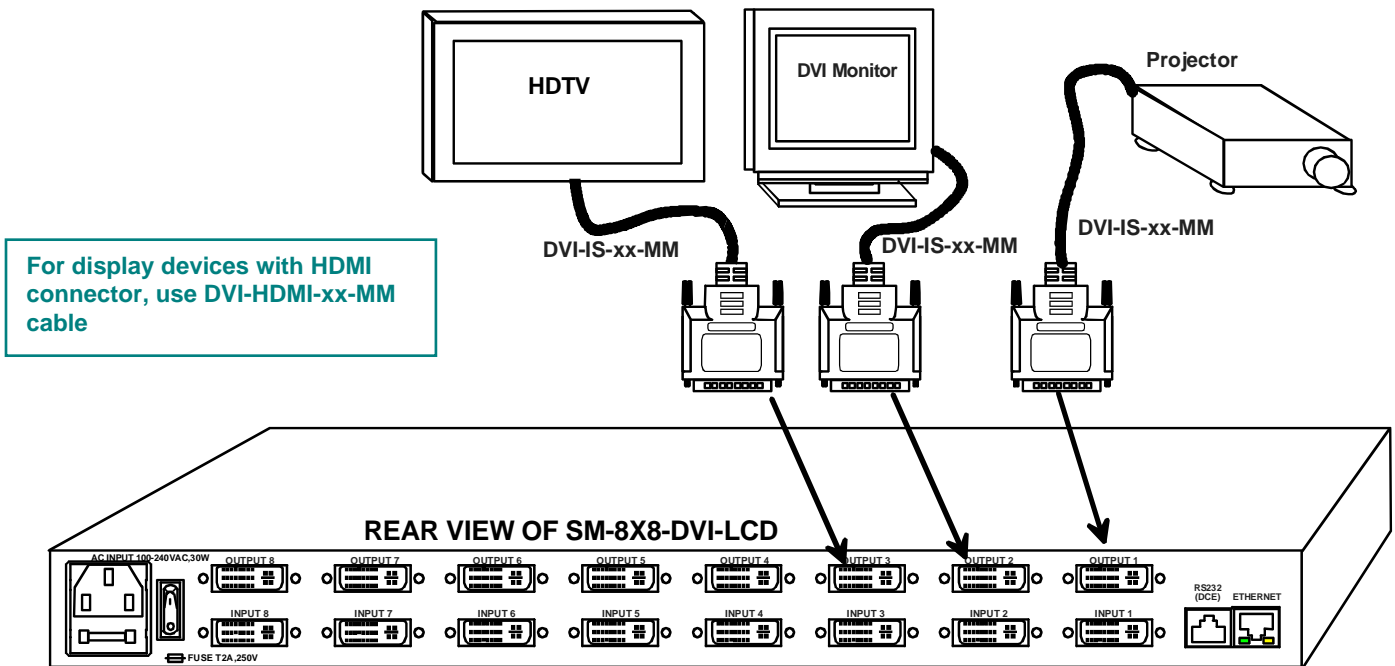

Figure 4- Connect display devices to VEEMUX

Note: DVI cables longer than 15 feet may provide poor video performance on this product.

3. If the VEEMUX will be controlled using RS232, then make a connection between the “RS232” port on the VEEMUX and a serial port on a PC. A DB9M-to-RJ45F adapter and 5 foot CAT5 patch cable have been provided to help with this connection if needed.

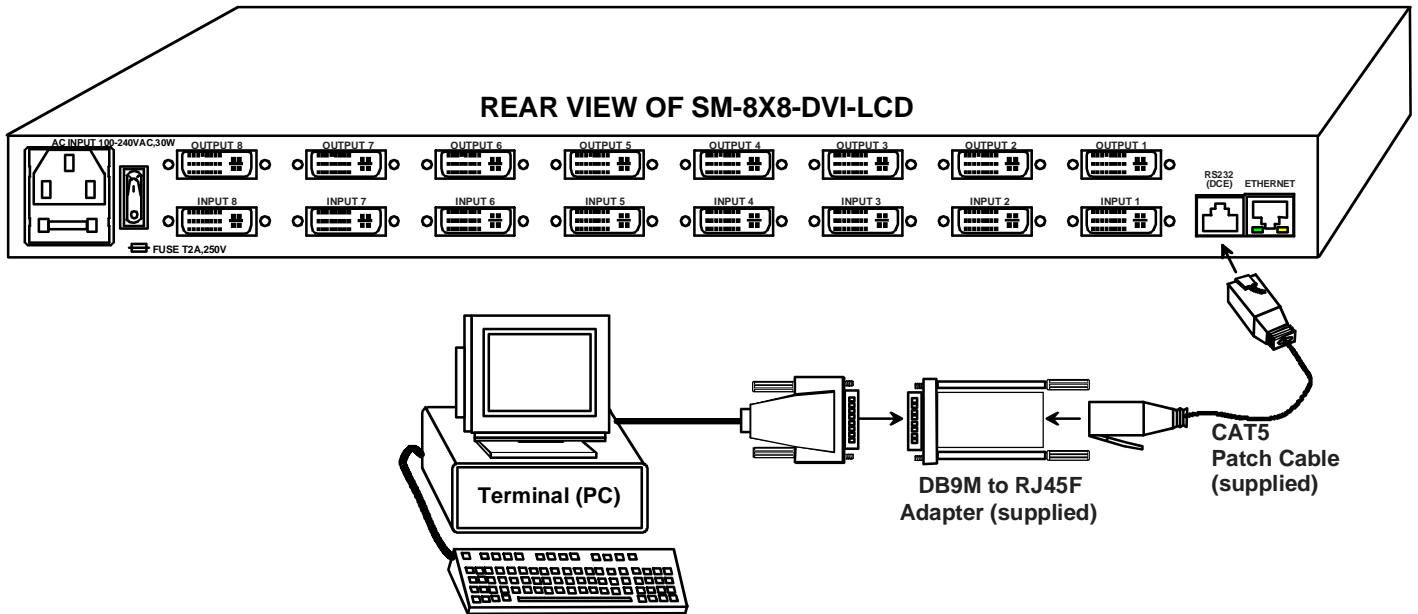

Figure 5- Connect RS232 control terminal to VEEMUX

3a. If the VEEMUX model is SM-4X4-DVI(A)-LCD, the switch has a USB Type B female port that can be used for RS232 connection to a PC. Connect a USB A-B cable (i.e. NTI P/N USB2-AB-xM-5T -available in 0.5,1,2,3 and 5 meter lengths) between the “USB CONSOLE” port on the VEEMUX and any available USB Type A port on a PC. For more on using the USB port on the SM-4X4-DVI(A)-LCD, see page 13.

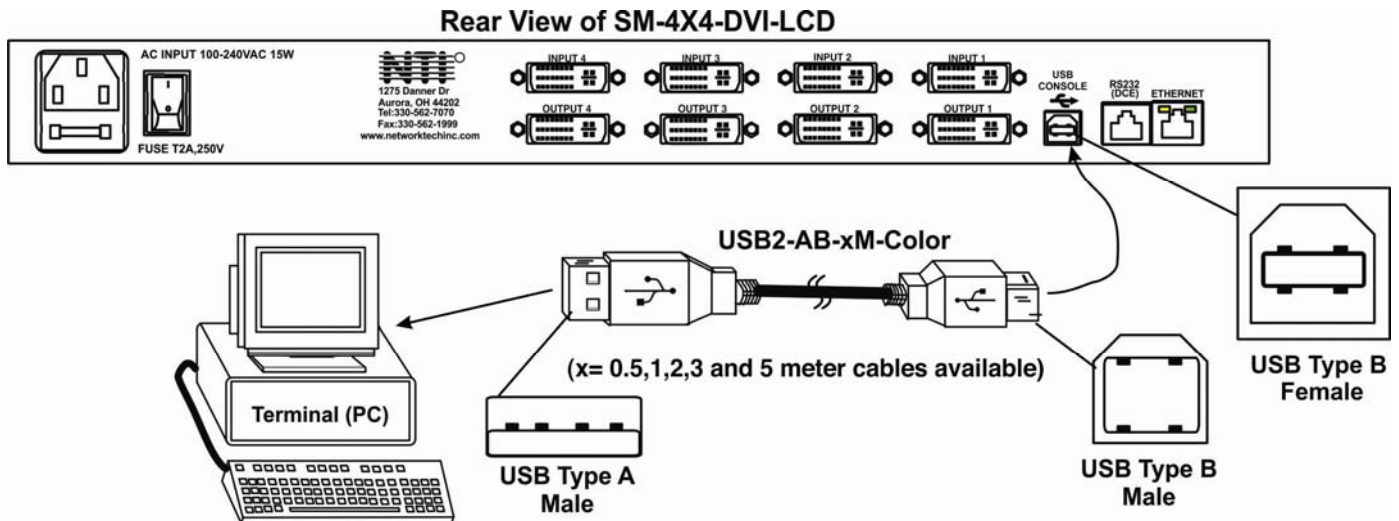

Figure 6- Connect RS232 using USB cable

4. To make a remote connection, over the Ethernet, from anywhere on the local area network, connect a CAT5/5e/6 Ethernet cable with RJ45 male connectors on the ends, wired straight through (pin 1 to pin 1, pin 2 to pin 2, etc.).

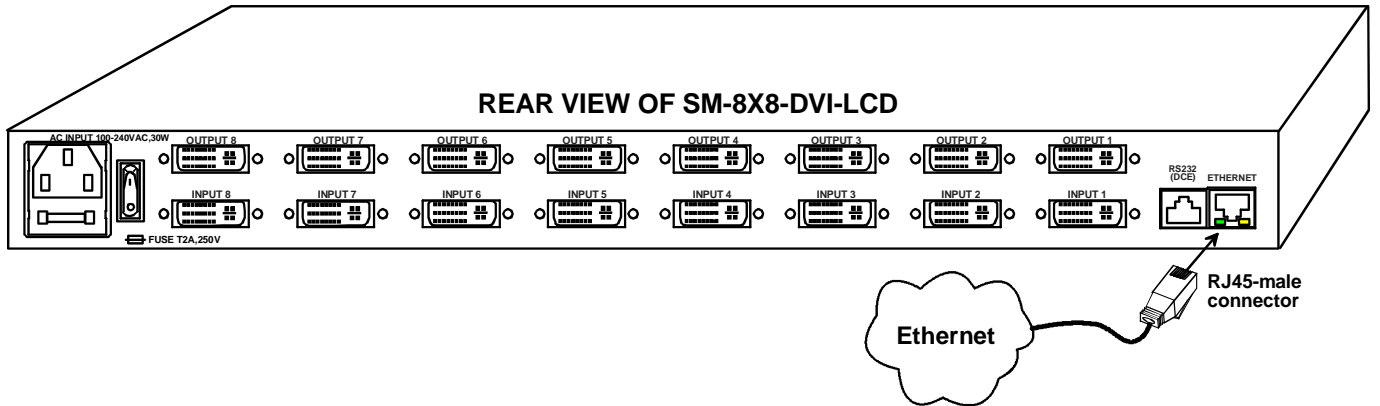

Figure 7- Connect VEEMUX to local area network

5. Connect the powercord to the VEEMUX and plug it in.

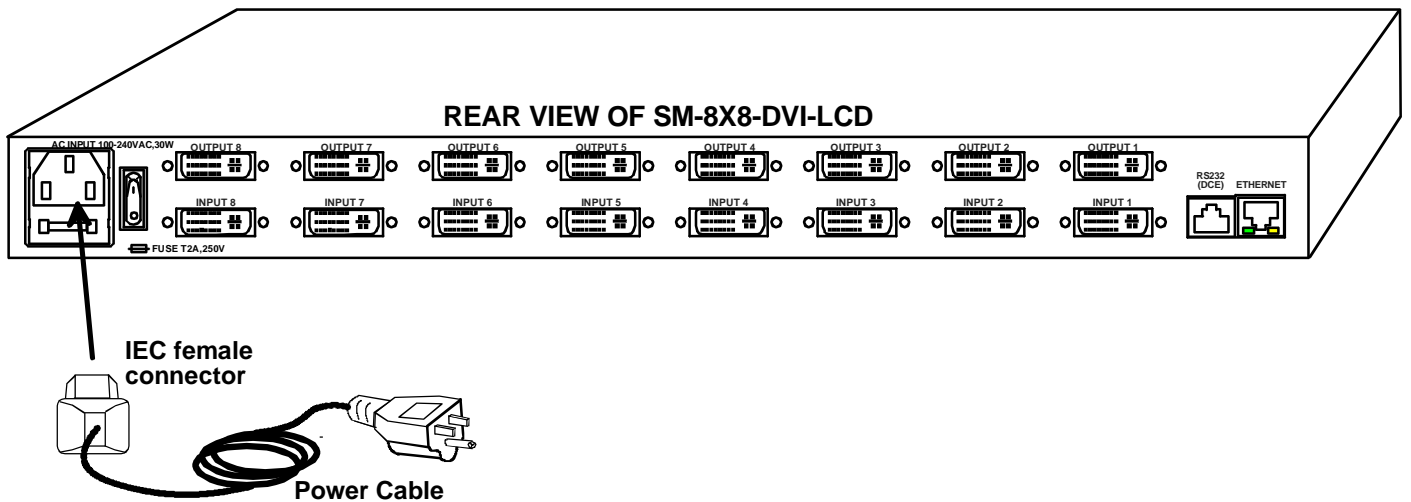

Figure 8- Attach AC power cord to VEEMUX

6. Power ON the components **in this order**:
 - A. Power ON the display devices
 - B. Power ON the VEEMUX. Wait for the LCD to display connections.
 - C. Power ON the video sources

Audio Connections

If this VEEMUX model has audio support, then connect 3.5mm cables from each audio source to the "AUDIO IN" ports and 3.5mm cables from self-powered stereo speakers to the "AUDIO OUT" ports.

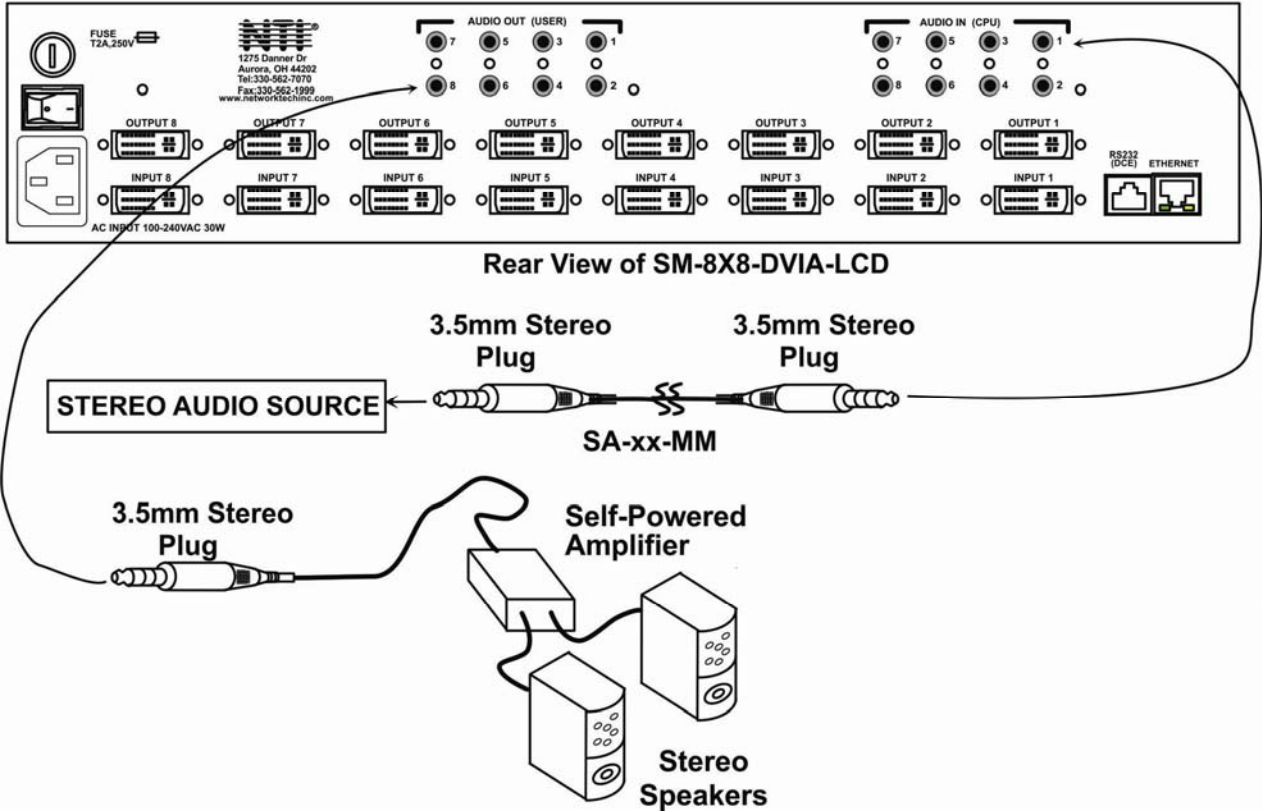

Figure 9- Connect Audio Source and Speakers

OPERATING THE VEEMUX

The VEEMUX video matrix switch has four methods of control:

- Front Panel LCD with Keypad
- Directly via an RS232 Interface
- Remotely via Ethernet
- Infrared Remote (optional).

Every unit comes standard with all control methods built-in. An IRT-UNV-IR Remote Control is required (purchased separately) to use the Infrared option. No software is involved (see Infrared Control on page 49). With the RS232 option, there are no external devices to be purchased. NTI provides software commands as well as a test program to ensure the RS232 functions properly (see page 18 – RS232 Control).

Front Panel LCD with Keypad Control

The front panel LCD and keypad allow the user to monitor switch status and route any user to any video source on the switch. When the unit is first powered-up, each monitor is automatically connected to the video source of its equal number (i.e. monitor 1 to source 1, monitor 2 to source 2, monitor 3 to source 3, etc.). (After configurations have been saved (page 33), upon power-up the VEEMUX will load the configuration saved into memory location 0.) Along with the routing of the inputs (video sources) to the outputs (monitors) the keypad and LCD allow the users to configure the RS232 control interface. The keypad buttons perform the following functions:

Model SM-8X8-DVI-LCD

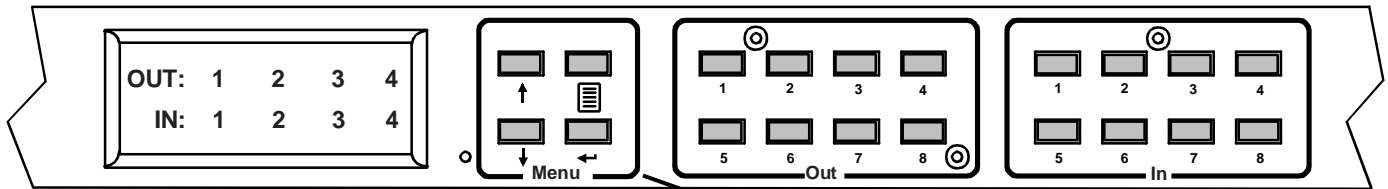

Key Functions:

- Up Arrow-** Scroll up the menu
- Down Arrow-** Scroll down the menu
- Left Arrow (Enter Key)-** Select the menu item
- List -** Open the menu, or exit the menu (also used to back out of the menu, one step at a time)
- Out-1- through 8** Used in command sequence to select which output (display device) to connect
- In-1-through 8** Used in command sequence to select which input (video source) to connect

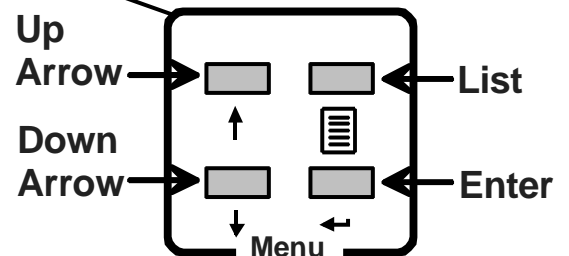

Note: Models with Video and Audio support will display a "v" or "a" next to the "IN" to indicate which ports connections are being displayed. When using the keypad, both video and audio connection changes are effected by selections. To make changes individually to video and audio connections, use either the web interface (page 47) or the optional infrared remote control (page 49).

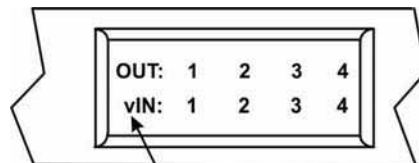

LCD WILL CYCLE TO DISPLAY A "v" FOR ALL VIDEO INPUTS FIRST, THEN A "a" FOR ALL AUDIO INPUTS.

To quickly change a connection, simply press an Out number followed by an In number corresponding to the display device you want to connect to the video source. Whether the **Out-x** button or the **In-x** button is pressed first doesn't make a difference.

To configure the VEEMUX, use the Menu keys.

Press the **List** button to list your main menu options:

- 1- Serial
- 2- Ethernet
- 3- DDC
- 4- Standby
- 5- Save Config
- 6- Load Config

Use the **Up** and **Down Arrow** keys to scroll through this list.

Use the **Enter** Key to select a menu item.

Press the **List** button again to exit the menu.

If, while in a menu, you pause for more than 5 seconds, you will automatically exit the menu.

LCD Menus

Serial Menu

Under the "Serial" menu are two parameters:

- 1- Baud rate
- 2- Address

These parameters are used when the VEEMUX is controlled through an RS232 connection (page 18). If you select Baud rate, use the arrow keys to toggle through the available baud rates. The baud rate can be set to 115200, 57600, 38400, 19200, 9600, 4800, 2400, or 1200.

If you select Address, use the arrow keys to toggle through the address options (01-15). This is also the switch address used in conjunction with the IR Remote operation (page 53).

Ethernet Menu

Under "Ethernet" menu are several parameters:

- 1- Mode
- 2- IP Address
- 3- Mask
- 4- Gateway
- 5- Pref. DNS
- 6- Alt. DNS

The Mode parameter will let you select between a manual IP setting, a DHCP assigned dynamic IP address setting, or disabling the Ethernet port. An asterisk indicates which mode is configured, an arrow shows which mode is being selected. To change the configured setting and move the asterisk, select the desired mode and press the **Enter** button.

If you choose a manual IP setting, the IP parameter provides the fields for entering a valid IP address. Use the up and down arrows to advance the numbers, and the **Enter** button to move from field to field. Press **List** to exit this screen.

Selections 3, 4 are necessary to apply valid values for your Subnet Mask and Gateway. Navigate these settings as described for setting the IP address.

Selections 5 and 6 are not used at this time and are therefore unnecessary.

DDC Menu

DDC enables the video source to get EDID information from the display device. This enables the video source to automatically select the optimal resolution for the display by receiving, at power up, information from the display device concerning its resolution specifications.

Under the “DDC” menu are five parameters:

- 1- **Chose Input** (Choose Input)
- 2- **All Inputs**
- 3- **FacDefault1**
- 4- **UsrDefault1**
- 5- **ReloadOptn**

1) **Choose Input**- select the EDID information source for each input individually, or

2) **All Inputs**- select EDID information source for all inputs at once.

Within these sections you will need to select between:

direct- (available in 4x4 and 8x8 models only) the video source on an input will get EDID information from the video display device that is first connected to the output, regardless of what other display devices are also connected to the video source

default 1- the inputs will get EDID information from a predefined table in the VEEMUX supporting CPU monitors

default 2- the inputs will get EDID information from a predefined table in the VEEMUX supporting televisions

From Out (?)- select which Output port the Input will get EDID information from regardless of which output it is connected to

DDC Mix(?)- select which Input will receive EDID information that is common to the Outputs selected on the “DDC Mix” page (page 42) for that input

More on “Direct” DDC: If the first output is switched to another input, the video source will look to the other connected outputs to get EDID information from, searching from the lowest numbered output port first.

For example: The video source on input 1 is connected to output 8, then 4, then 2, and then 5 for a total of 4 display connections. The video source gets it EDID from output 8, the first connected output. If output 8 is switched to another video source, the video source on input 1 will then get EDID information from output 2.

3) **FacDefault1**- Select this to use the factory default EDID data for DDC “Default 1” configuration

4) **UsrDefault1**- Select this to replace the EDID information stored in the VEEMUX for “Default 1” with the EDID data from the monitor presently connected to Output 1.

5) **ReloadOptn**- Select this and choose to **enable** or **disable** this feature. When enabled, the switch will refresh DDC data stored in the VEEMUX each time the VEEMUX is power-cycled. The DDC data will be based on the current DDC configuration settings.

Standby

The fourth option in the main menu is “Standby”. When Standby is selected, the VEEMUX switch will immediately go into a power saver mode and the LCD display will go blank. It will remain in this state until

- 1) any button is pressed on the front panel,
- 2) the Standby button is pressed on the optional IR Remote Control (page 50), or
- 3) the “Disable Standby” button is pressed in the web interface (page 45)

Models SM-16X16-DVI-LCD and SM-32X32-DVI-LCD

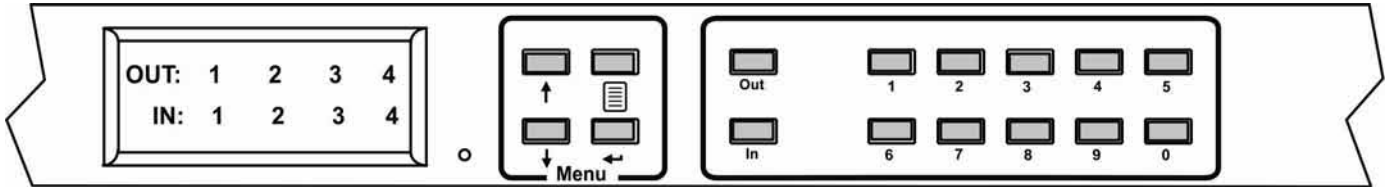

The keypad control for the 16X16 and 32X32 models is very similar to that of the 8X8, with these differences:

- The “In” and “Out” ports are selected by pressing the associated port number and then the “In” or “Out” button to designate the video source or the display (respectively). Alternatively, the “In” or “Out” button can be pressed, then the port number, followed by the “Enter” button.
- Multiple displays can be connected to a single video source using one command sequence:
`<In> xx<Out>xx<Out>xx<Out>xx<Out>xx<Enter>` or
`<Out>xx<Out>xx<Out>xx<Out>xx <In> xx <Enter>` (where xx is the port number)
- Within the “DDC” menu, “Default 1”, “default 2”, and “From Out (?)” will work as described on the previous page, however the “direct” option is not applicable.
- The main menu has two additional options, **5-Save Config** and **6-Load Config**, described below
- The list of current connections shown on the LCD screen can be scrolled using the **Up** and **Down Arrows**, rather than waiting for them to show the connection you are looking for.

Save and Load (Recall) Config

The SM-16X16-DVI-LCD and SM-32X32-DVI-LCD switches provide the ability to save and recall up to 100 switch configurations using the LCD menu. The switch configurations define the current port connections, volume control settings, and video blank status.

Note: *The IRT-UNV IR Remote (page 49) can also be used to access these configurations by using the “SAVE” and “RECALL” buttons.*

To save a configuration, select “Save Config” from the main menu followed by a numeric button(s) (0-99) corresponding to the memory slot the configuration is to be saved in. Press **Enter** after your selection to force the current configuration to immediately be saved to the selected memory slot.

Configurations can be loaded (recalled) in much the same manner. To recall, select “Load Config” from the main menu followed by the numeric button(s) (0-99) corresponding to the memory slot from which the configuration is to be recalled. Press **Enter** after your selection to immediately force the switch to change the current switch configuration to match that of the configuration recalled.

USB Console Port

If your VEEMUX is model SM-4X4-DVI(A)-LCD and you have connected a USB cable between the VEEMUX and your PC (page 6), you will be able to control your VEEMUX serially from a terminal console using this connection.

Installing Drivers

You will only need to install drivers the first time the VEEMUX is connected to your PC. After the first time, when the VEEMUX is connected your PC should recognize the VEEMUX and re-assign the COM port. Follow the steps below to install the drivers.

1. Make sure the USB cable is connected between the VEEMUX and your PC.
2. Power ON the VEEMUX. The PC will see the VEEMUX as "New Hardware" and create a virtual COM port to communicate with it.
3. You will be prompted to load drivers. A driver file compatible with Windows XP, 2000, Vista and 7 (32 and 64 bit versions) can be found on the CD that came with your VEEMUX. Browse to the drive your Product Manual CD is in and locate and select the file named "veemux_mxn_dvi.inf" in a directory named "windows-drivers\32bit or \64bit" depending upon your operating system.

The .inf file will direct your PC to locate and install the file `usbser.sys` (already on your PC, comes with Windows). Installing the `usbser.sys` file should happen automatically. When finished, Windows will indicate installation is successful.

Windows XP-32 bit Installation

Your typical installation will include windows like the ones that follow. The images below are from a Windows XP SP2 32 bit installation.



A. Windows will want to check the internet for drivers. Choose **"No, not this time"** because the drivers are unique to the VEEMUX.

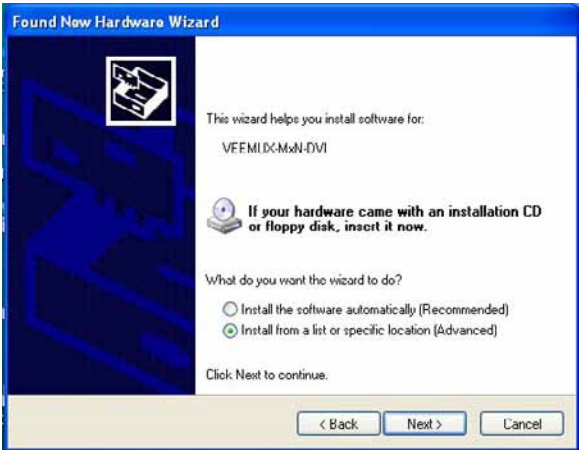
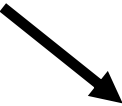

B. You can try to **"Install the software automatically"** but if windows doesn't check the CD, you will need to use **"Install from a list or specific location"** instead.

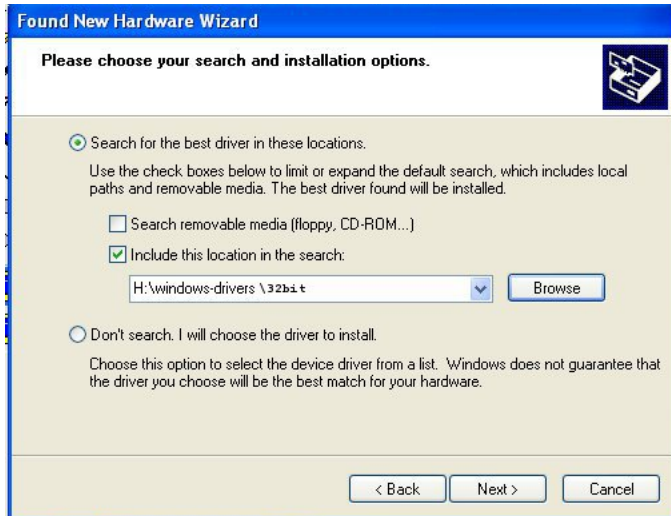

C. Let the New Hardware Wizard search for the driver, but direct it to the drive the Product Manual CD is in and the directory of either the 32 bit driver or the 64 bit driver.



D. Once the driver is installed, you will get this screen and the VEEMUX USB Console Port will be ready to use. .



Windows 7-64 bit Installation

A Windows 7 64 bit installation has a few extra steps. The images below are from a Windows 7, 64-bit installation.



A. Upon VEEMUX power ON, the driver cannot be found. Press **“Close”**.

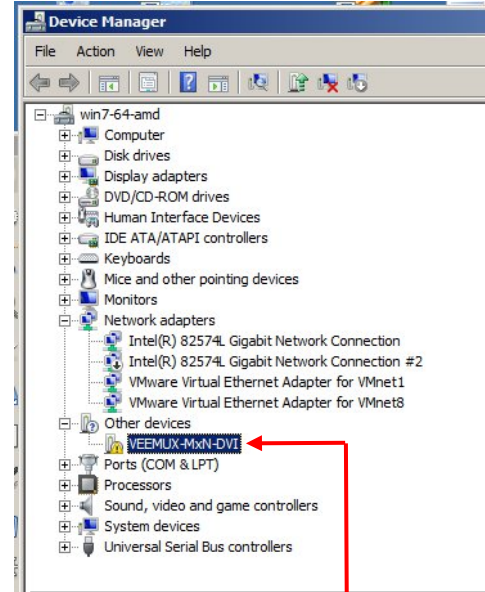

B. Open the Device Manger and select the VEEMUX in the device list. Right-click and open **“Properties”**. Select **“Update Driver Software”**.

Tip: The Devider Manger can be opened by right-clicking on “My Computer” on the desktop, selecting “Properties”, and selecting “Device Manager”.

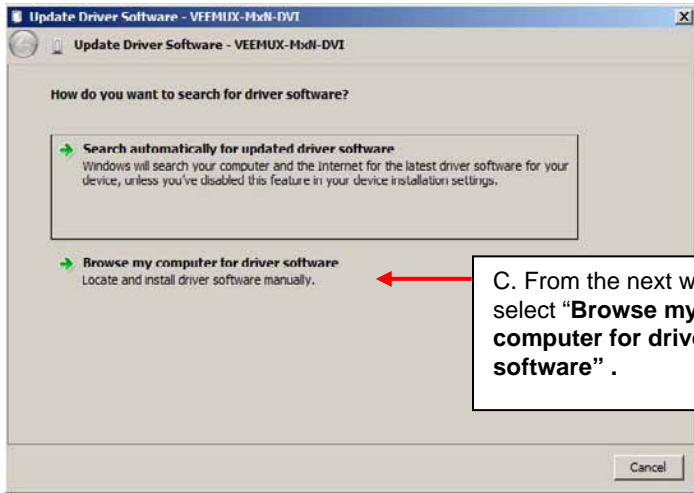

C. From the next window, select **“Browse my computer for driver software”**.

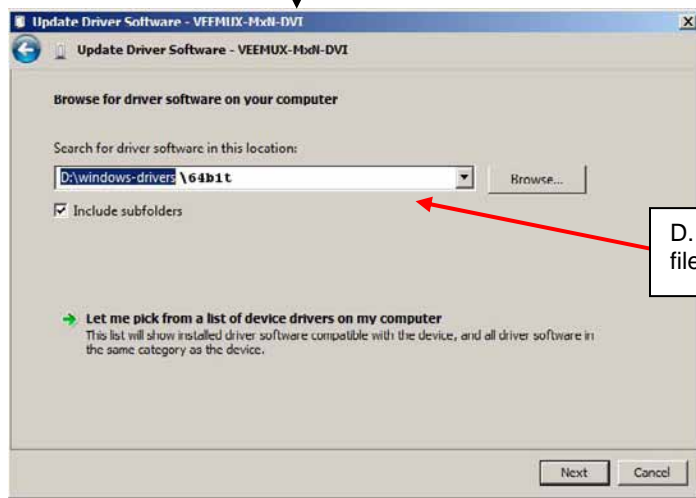

D. In the next window, enter the path to the .inf driver file (on the Product Manual CD). Press **“Next”**.

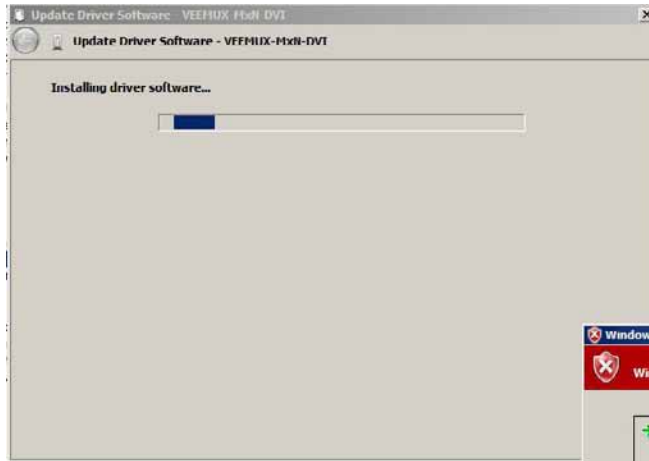

E. You will probably get this warning that Windows can't verify the publisher of the driver software. Select **“Install this driver software anyway.”**

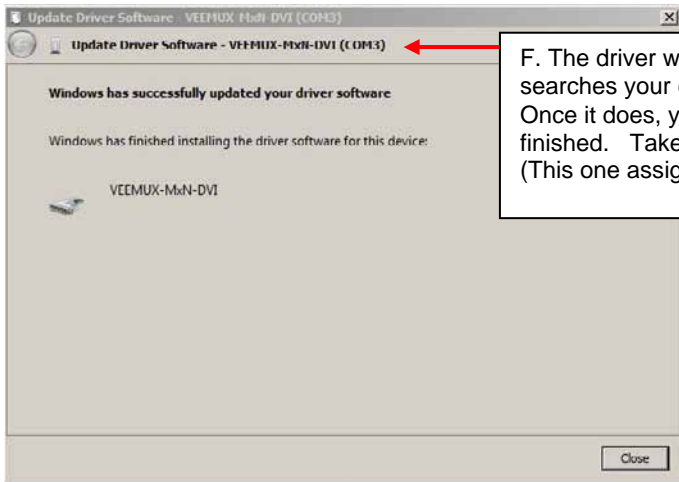
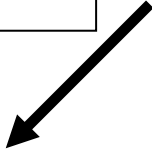

F. The driver will load. This might take a minute while it searches your computer for the `usbser.sys` file it needs. Once it does, you will get a window telling you Windows is finished. Take note of the COM port number it assigned. (This one assigned COM3.)

4. During the installation, your PC will assign a COM port number to the USB port attached to the VEEMUX. You will need to identify the COM port number assigned. This information can be viewed in your Device Manager list (below) if you didn't take note of it during installation.

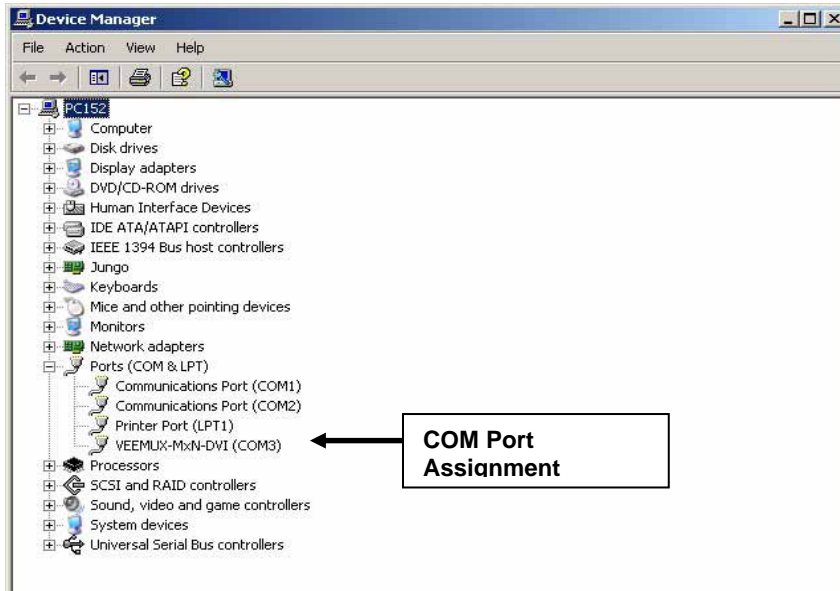

Figure 10- COM port assigned to VEEMUX

Using the USB Console Port

The virtual COM port will be used to enable serial control over the VEEMUX (see RS232 control on page 18). When you open a terminal program or the Matrix Switcher's Control Program (page 21), you will need to configure the program to use the correct COM port (see Figure 10 and Figure 11).

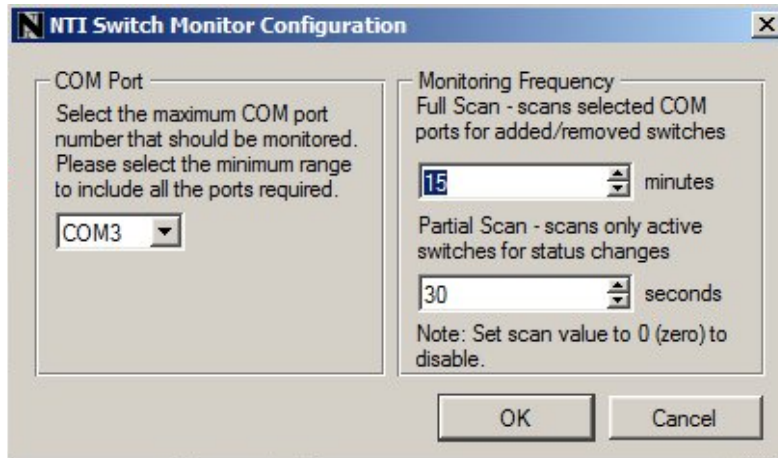

Figure 11- Configure COM port in Matrix Switcher's Control Program

RS232 CONTROL

RS232 enables the VEEMUX to be remotely controlled via RS232. To control the VEEMUX via RS232 the user has three options:

- write a program that runs on a PC using the Command Protocol (page 20)
- use the Matrix Switcher's Control Program (page 21) provided on the CD
- use the SerTest program (page 22) provided on the CD

Remote Connection

The RS232 Interface is designed to meet the RS232C standard and can be controlled from any CPU or other controller with an RS232 communications port. The pin-out for the RJ45 connector on the unit is as follows:

RS232 (RJ45) CONNECTOR

PIN	SIGNAL	FUNCTION
1	-	No connection
2	-	No connection
3	RX+	Receive data (TXD at host)
4	GND	Ground
5	-	No connection
6	TX+	Transmit data (RXD at host)
7	-	No connection
8	-	No connection

A 5 foot patch cable and adapter, RJ45-to-DB9, have been provided for connection to most CPUs (see page 6). To daisy chain multiple units, connect a Matrix-Y-1 cable (sold separately) between the CPU and the first switch, and between each switch (as shown in Figure 12).

Baud Rate

The baud rate can be changed by selecting MENU on the front panel keypad, using the OSD menu, using Telnet commands (page 24) or from the RS232 commands (page 20). The baud rate can be set to 115200, 57600, 38400, 19200, 9600, 4800, 2400, or 1200. A data protocol of 8 data bits, no parity, and 1 stop bit is used for communications. The default baud rate setting is 9600.

Unit Address and Loop Back

To allow multiple units to be controlled from a single host port, the RS232 control interface is designed to allow "daisy chaining" up to 15 units using an NTI Matrix-Y-1 cable. Connect the Matrix-Y-1 cable between the RJ45-to-DB9 serial adapter (provided with the RS232 option) and the CPU as shown in Figure 12. By setting the appropriate unit address (page 10), each unit can be given a unique address (1-15). Then the unit will only respond to commands on the bus if its address is embedded in the command.

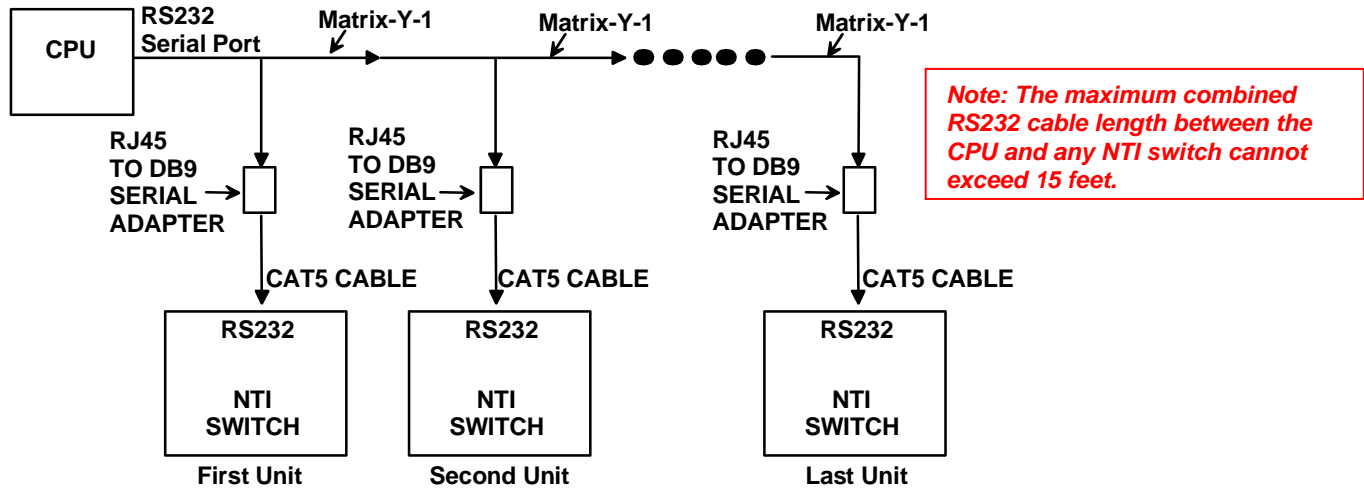

Figure 12- RS232 connection with Matrix-Y-1 cable

Wiring Schematic of Matrix-Y-1 cable

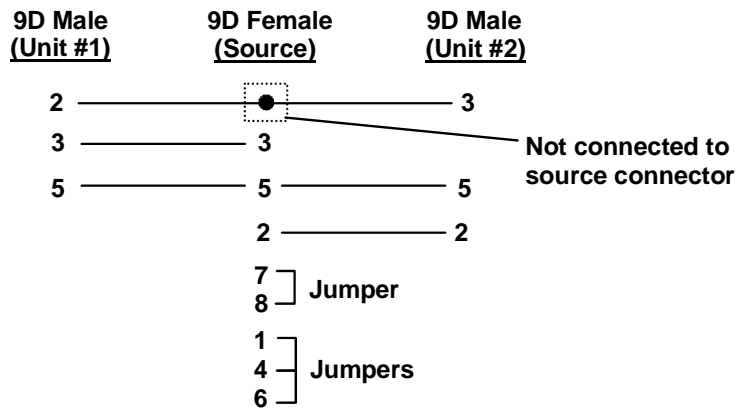

Figure 13- Pinout of Matrix-Y-1 cable

Command Protocol

CPU controller commands supported by the unit are defined below. All commands must be terminated with a <CR> (carriage return). When a command is sent, the entire string is echoed back along with a response from the addressed unit as shown in the Command Definitions table (below). All characters in the command string are case sensitive (see Command Definitions table), and all numbers below 10 must have a leading 0 (ex: 1 = 01).

Legend:

(All numbers must be two digits)

SW	:	Switch (01-15)	MM	:	Save Into Memory Bank (00-99)
BR	:	Baud Rate Code	LL	:	Load From Memory Bank (00-99)
OP	:	Output Port (01-MAXOUTPUTS)	<CR>	:	Carriage Return (Hex 0xD)
IP	:	Input Port (01-MAXINPUTS)	ip	:	IP address

Command Definitions

Command String	Good Response	Description
CS SW,IP,OP	*<CR>	VIDEO Connect One Output/User Port To Input/CPU Port
CA SW,IP	*<CR>	VIDEO Connect All Output/User Ports To Input/CPU Port
RO SW,OP	*<CR>IP<CR>	VIDEO Read Connection For Output/User Port
VB SW,OP,01	*<CR>	Blank the video for specific Output/User Port
VB SW,OP,00	*<CR>	Unblank the video for specific Output/User Port
CC SW,MM	*<CR>MM<CR>	Save Matrix Connections Into Memory Bank xx Xx=00-99
RC SW,LL	*<CR>LL<CR>	Restore Matrix Connections From Memory Bank
CB 00,BR	None	Change baud rate of serial line, BR=11(5200),57(600),38(400),19(200)96(00),48(00),24(00),12(00) Factory default is 9600
RS SW	*<CR>	Internal Reset
RV SW,00	*<CR>string\0<CR>	Read NTI Version String
RU SW	*<CR>IP,OP<CR>	Read Unit Size
EA SW,ip	*<CR>	Set the IP address, ip is in xxx.xxx.xxx.xxx format, number of digits is minimum 1 and maximum 3 for each field Leading zeroes are accepted
EM SW,ip	*<CR>	Set the Subnet mask, ip is in xxx.xxx.xxx.xxx format, number of digits is minimum 1 and maximum 3 for each field. Leading zeroes are accepted
EG SW,ip	*<CR>	Set the default gateway, ip is in xxx.xxx.xxx.xxx format, number of digits is minimum 1 and maximum 3 for each field Leading zeroes are accepted
ET SW,timeout	*<CR>	Set the website timeout; timeout = numeric string of timeout in seconds. Values: 60, 300, 600, 900, 1800, 3600, 7200, 18000, 28800
RA SW*	<CR>ip<CR>	Read the IP address, ip is in xxx.xxx.xxx.xxx format, number of digits is minimum 1 and maximum 3 for each field Leading zeroes are accepted
RM SW*	<CR>ip<CR>	Read the Subnet mask, ip is in xxx.xxx.xxx.xxx format, number of digits is minimum 1 and maximum 3 for each field Leading zeroes are accepted
RG SW*	<CR>ip<CR>	Read the default gateway, ip is in xxx.xxx.xxx.xxx format, number of digits is minimum 1 and maximum 3 for each field Leading zeroes are accepted
RT SW*	<CR>timeout<CR>	Read the website timeout; timeout = numeric string of timeout in seconds. Values: 60, 300, 600, 900, 1800, 3600, 7200, 18000, 28800
SS SW,00	*<CR>	Disable Autostatus feature (see below)
SS SW,01	*<CR>	Enable Autostatus feature (see below)
GO SW,OP	*<CR>go SW,OP,IP<CR>	Read connection of a Video Output Port to Video Input Port
GM SW,00	*<CR>go SW,OP,IP (all ports)<CR>	Read connection matrix of all Video Output ports

If the first field is not a known command (as listed above) or SW field is different from the serial address programmed in the switch memory, the command will be ignored. If the SW field corresponds to the unit address, but the syntax is wrong after this field, the switch will answer with a bad response ?<CR>.

Additional Command Definitions for Audio Option

Command String	Good Response	Description
AS SW,IP,OP	*<CR>	AUDIO Connect One Output/User Port To Input/CPU Port
AA SW,IP	*<CR>	AUDIO Connect All Output/User Ports To Input/CPU Port
AO SW,OP	*<CR> P<CR>	AUDIO Read Connection For Output/User Port
AM SW,OP,MU	*<CR>	Set Mute State For Output/User Port
AV SW,OP,VV	*<CR>	Set Volume Level For Output/User Port See chart on page 21 for values
AR SW,OP	*<CR>MU,VV<CR>	Read Mute, Volume For Output/User Port MU is 00 if the port is UNMUTED, MU is 01 if the port is MUTED. VV is a value between 00 to 99 (see chart below)

Set Volume Level For Output/User Port (for command string AV SW,OP,VV in chart above)

This command will set the volume of the specified AUDIO output/user port from a scale of 00 to 99, which represents a logarithmic volume.

Serial Data (VV)	Audio Volume
90 – 99	+10dB
80	0dB
60	-20dB
0 – 28	-52dB

Autostatus

When Autostatus is enabled, any output-to-input connection change in the VEEMUX will cause an Autostatus message to be sent via RS232 to the administrator. The format of the message would be "pc SW,OP:IP<CR>"

Example of an Autostatus message:

pc 01,01:04<CR>

which means "At the switch with unit address 01, the output (01) has changed connection to input 04."

Notes: *Message to the administrator will be delayed by any RS232 traffic being received by the switch from the administrator.
Autostatus must be disabled before using SerTest or the Matrix Switcher's Control Program (page 21).*

By default, Autostatus is disabled and must be manually enabled. Autostatus is also disabled any time the power to the VEEMUX is interrupted.

Matrix Switcher's Control Program For Windows 9X, NT, 2000, XP, Vista and 7

The Matrix Switcher's Control Program is an easy and powerful graphical program that controls NTI matrix switches through an RS232 interface. The Matrix Switcher's Control Program is downloaded by clicking on the link "Download Matrix Switcher's Control Program" found on the web page that appears when you insert the instruction manual CD into your CD ROM drive.

To install the Matrix Switcher's Control Program after downloading

1. Locate the **Setup.exe** in the directory the program was downloaded to and double-click on it
2. Follow the instructions on the screen

The Matrix Switcher's Control Program performs best on monitors set to a screen resolution of at least 800 X 600. Instruction for using the Matrix Switcher's Control Program is available by opening "MSCP Help" in the "NTI" program group once the program has been installed and is open on the screen.

To open "MSCP Help" from the Windows desktop

1. Click on **START**
2. Click on **PROGRAMS**
3. Click on **NTI**
4. Click on **MSCP Help**

Note: *While in Scan Mode, the video radio buttons shown on the Switch page of the Matrix Switcher's Control Program may not be in sync with the connection changes within the VEEMUX. Connections will change without updating the image on the screen.*

SerTest- RS232 Interface Test Program

This software allows a user to test the functions of an NTI server switch, matrix switch or Multi-user/Multi-platform switch RS232 interface. The SerTest program is automatically loaded when installing the Matrix Switcher's Control Program as described above. The SerTest program, located in the NTI program group, generates a main menu with the 4 selections described below:

Main Options

- Matrix Operations - send commands to the matrix unit.
- Ethernet Operations - set Ethernet connection variables
- Setup Options - set COM port, baud rate, and unit address
- About SerTest - display the program version

Matrix Operations

Key	Selection	Description
1)	Connect Video Output/User to an Input/CPU	- connect an output to an input
2)	Connect All Video Outputs/Users to an Input/CPU	- connect all outputs to an input
3)	Connect Audio Output/User to an Input/CPU	- connect an output to an input (audio ports only)
4)	Connect All Audio Outputs/Users to an Input	- connect all outputs to an input (audio ports only)
5)	Change Mute Status for Audio Output/User	- mute or un-mute the Audio port output
6)	Change Volume for Audio Output/User	- change Audio port output volume
7)	Read Connection for Video Output/User	-read the connection of a specific video output
8)	Read Connection for Audio Output/User	-read the connection of a specific audio output
9)	Read Mute and Volume for Audio Output/User	- read the volume and the mute status of the specified output (audio ports only)
a)	Save I/O Connections into Unit Memory	-save the connections into switch memory bank
b)	Restore I/O Connections from Unit Memory	-restore the connections from switch memory bank
c)	Change All Units Baud Rate (9600/COM1:)	-change RS-232 Baud rate of all switches -the current baud rate and serial port are displayed in parentheses
d)	Reset Unit	- send a reset command to the switch - the current unit address is displayed in parentheses
e)	Reset All Units	- send an internal reset command to all switches
f)	Read Unit Size	- read the switch size (number of inputs and outputs)
g)	Read Unit Version/Revision String	-read a string containing the switch version, type, and size
h)	Save All Units I/O Connections into Units Memory	-save the connections into switch memory bank, command for all switches
i)	Restore All Units I/O Connections from Units Memory	-restore the connections from switch memory bank, command for all switches

Grayed keys are for models with audio support

Ethernet Operations

Key	Selection	Description
1)	Set Unit IP Address	- enter the desired IP address in xxx.xxx.xxx.xxx format - number of digits is minimum 1 and maximum 3 for each field. Leading zeroes are accepted
2)	Set Unit Subnet Mask	- enter the desired IP address in xxx.xxx.xxx.xxx format - number of digits is minimum 1 and maximum 3 for each field. Leading zeroes are accepted
3)	Set Unit Default Gateway	- enter the desired default gateway - number of digits is minimum 1 and maximum 3 for each field. Leading zeroes are accepted
4)	Set Unit Website Timeout	- set the website timeout; timeout = numeric string of timeout in seconds - Values: 60, 300, 600, 900, 1800, 3600, 7200, 18000, 28800 0 = no timeout
5)	Read Unit IP Address	- read the unit IP address in xxx.xxx.xxx.xxx format
6)	Read Unit Subnet Mask	- read the unit subnet mask in xxx.xxx.xxx.xxx format
7)	Read Unit Default Gateway	- read the unit default gateway in xxx.xxx.xxx.xxx format
8)	Read Unit Website Timeout	- read the current website timeout period in seconds - Values: 60, 300, 600, 900, 1800, 3600, 7200, 18000, 28800 0 = no timeout

Setup Options

Key	Selection	Description
1)	select Com port current: (COM1:)	- select PC serial port - the current PC serial port is displayed in parentheses
2)	select Baud rate current: (9600)	- select PC serial port baud rate - the current baud rate is displayed in parentheses
3)	set unit Address current: (1)	- select the unit address - the current address is displayed in parentheses
4)	set read timeout (5)	- select the time period (in seconds) the SerTest will wait for an answer to a command - the current time period is displayed in parentheses

For any selection that requires user input, the user is prompted. When commands are sent to the matrix unit, the command string and matrix unit responses are echoed to the screen. All commands generated by the program are formatted according to the information provided in sections above. If any transmission problems are detected, an error message is displayed.

Press <Esc> or <Enter> to back out to the main menu and press again to exit.

ETHERNET CONTROL

Telnet Interface-Port 2000

The Telnet Interface enables the user to control the switch using telnet client through an Ethernet connection. The telnet server listens on ports 2000 and 2005. Port 2000 is for an operator telnet session while port 2005 (must be enabled) is intended for a software control type session (see page 26). For operator telnet control using the telnet interface and the current IP address, type the following in a command shell:

telnet 192.168.1.30 2000

The VEEMUX will prompt the user for a password. The user must enter the password followed by <Enter>.

The factory default password is "nti".

With a proper password sent the VEEMUX will respond with:

***Password Successful
Connection Established***

The commands below are now available.

Telnet Interface- Port 2000 Commands

Command	Reply	Description
H(elp) or h(elp)	Displays the list of commands	Help
CS nn,mm	*<CR>	Connect One input nn To output mm
CA nn	*<CR>	Connect All Outputs To Input nn
RO mm	*<CR>nn<CR>	Read Connection For Output. Returns the number of the input nn connected to output mm
CC nn	*<CR>nn<CR>	Save Matrix Connections Into Memory Bank nn nn should be between 00 and 99
RC nn	*<CR>nn<CR>	Restore Matrix Connections From Memory Bank nn nn should be between 00 and 99
CB nn	*<CR>	Change baud rate of serial line, nn=12(00),24(00),48(00),96(00) Factory default is 9600.
RV 00	*<CR>string<CR>	Read NTI Version String
RU	*<CR>nn,mm<CR>	Read Unit Size Returns the number of inputs nn and the number of outputs mm
RS	*<CR>	Reset Unit
AS nn,mm	*<CR>	Connect audio input nn to output mm
AA nn	*<CR>	Connect audio input nn to all outputs
AO mm	*<CR>mm<CR>	Read audio connection for output mm
AM nn,mu	*<CR>	Set mute state for output nn mu(te State) = (00=UNMUTE, 01=MUTE)
AV mm,vv	*<CR>	Set volume level for output mm vv is a value between 00 to 99 (see chart page 21)
AR nn	*<CR>MU,VV<CR>	Read mute, volume for output nn MU is 00 if the port is UNMUTED, MU is 01 if the port is MUTED. VV is a value between 00 to 99 (see chart page 21)
Ss nn,dwt	*<CR>	Set value of Scan Mode dwell time (see page 9) for specific Output (nn) dwt = 000-255 (seconds) 000= disable Scan Mode

Command	Reply	Description
Gs nn	*<CR> dwt<CR>	Read set Scanning Sequence dwell time value (dwt) for specific Output (nn) in seconds (see also "Scanning Sequences" on page 38)
Sa nn,mm	*<CR>	Set scan list of individual output nn to all inputs mm
Sc nn	*<CR>	Clear scan list of individual output nn
S+ nn,mm	*<CR>	Add input mm to Scan List of output nn
S- nn,mm	*<CR>	Remove input mm from Scan List of output nn
Sx nn	*<CR>oooxxxxooooxxx<CR>	Display the Scan List of output nn (o=skip x=don't skip)
CP	User is prompted to introduce the password twice	Change password- five (5) characters minimum
<Ctrl>-<X> (see note 4 below)	Good Bye. Connection to host lost.	Quit telnet session
H(elp) or h(elp)	Displays the list of commands	Help

Grayed commands are for models with audio option.

Notes:

1. The commands must be typed exactly as shown in the chart. The commands are case sensitive.
2. If a mistake is made, the user must backspace to the beginning and completely retype the command.
3. If a command is sent that the VEEMUX does not recognize or exceeds the configuration of the switch, the reply "?" may be received. Check the command syntax and try again.
4. To quit the telnet session, press the keyboard keys <Ctrl><X> + <Enter>.

Telnet Interface-Port 2005

For a software control type of telnet interface session (versus operator telnet control through port 2000 as described on page 24), connect to the VEEMUX through the current IP address at port 2005. Use the command set below to control and acquire information from the VEEMUX.

Note: After establishing the connection, the unit will answer with a blinking prompt on the next line. If the connection fails it will answer with ?<CR>

Legend: (All numbers must be two digits)

OP : Output Port (01-MAXOUTPUTS)
 IP : Input Port (01-MAXINPUTS)
 <CR> : Carriage Return (Hex 0xD)

Command Summary

Command String	Good Response	Description
RU<CR>	ru IP,OP<CR>	Read unit size
RO OP<CR>	pc OP,IP<CR>	Read connection for OP
CS IP,OP<CR>	*<CR>	Connect OP to IP
CA IP<CR>	*<CR>	Connect all outputs to IP
SS 01<CR>	*<CR>	Enable auto-status mode
SS 00<CR>	*<CR>	Disable auto-status mode
SX<CR>	See details	Examine connections
AO OP<CR>	ac OP,IP<CR>	Read audio connection for OP
AS IP,OP<CR>	*<CR>	Connect audio OP to IP
AA IP<CR>	*<CR>	Connect all audio outputs to IP
AV OP,VV<CR>	*<CR>	Set audio volume for OP
AM OP,MM<CR>	*<CR>	Set audio mute status for OP
AR OP<CR>	ar OP:MM,VV<CR>	Read mute and volume for OP
XX<CR>	*<CR>	Close connection

Grayed commands are for models with audio option

A <CR> (carriage return, 0x0D) is considered to be the end of the command string. If a string exceeds 16 characters, an end of string will be inserted automatically to avoid buffer overflow. An eventual <LF> (line feed, new line, 0x0A) after a <CR> will be ignored. A bad string will always be responded to with the ASCII character '?' followed by a <CR>.

Note: Always be sure to terminate your telnet session with the <X> - <X> - <Enter> command string.

Command Detail

RU-Read Unit Size

Command:

Byte 1	Byte2	Byte3
'R' (0x52)	'U' (0x55)	<CR> (0x0D)

Response:

Byte 1	Byte 2	Byte 3	Byte 4	Byte 5	Byte 6	Byte 7	Byte 8	Byte 9
'r' (0x72)	'u' (0x75)	Space (0x20)	Input – 1st digit (0x30...0x32)	Input – 2nd digit (0x30...0x39)	',' (0x2C)	Output – 1st digit (0x30...0x32)	Output-2nd digit (0x30...0x39)	<CR> (0x0D)

This command will read the size of the unit. The response returns the number of inputs and the number of outputs in two-digit, ASCII code format. If the numbers are smaller than 10, the 1st digit is '0'.

RO-Read Connection for Output Port

Command:

Byte 1	Byte 2	Byte 3	Byte 4	Byte 5	Byte 6
'R' (0x52)	'O' (0x4F)	Space (0x20)	Output – 1st digit (0x30...0x32)	Output – 2nd digit (0x30...0x39)	<CR> (0x0D)

Response:

Byte 1	Byte 2	Byte 3	Byte 4	Byte 5	Byte 6	Byte 7	Byte 8	Byte 9
'p' (0x70)	'c' (0x63)	Space (0x20)	Output – 1st digit (0x30...0x32)	Output-2nd digit (0x30...0x39)	',' (0x2C)	Input – 1st digit (0x30...0x32)	Input – 2nd digit (0x30...0x39)	<CR> (0x0D)

This command will read the connection of an output port. The response returns the output port that is connected to the input port.

CS- Connect Output Port to Input Port

Command:

Byte 1	Byte 2	Byte 3	Byte 4	Byte 5	Byte 6	Byte 7	Byte 8	Byte 9
'C' (0x43)	'S' (0x53)	Space (0x20)	Input –1st digit (0x30...0x32)	Input –2nd digit (0x30...0x39)	',' (0x2C)	Output – 1st digit (0x30...0x32)	Output – 2nd digit (0x30...0x39)	<CR> (0x0D)

Response:

Byte 1	Byte 2
'*' (0x2A)	<CR> (0x0D)

This command connects the specified input port to the specified output port.

CA- Connect All Output Ports to Input Port

Command:

Byte 1	Byte 2	Byte 3	Byte 4	Byte 5	Byte 6
'C' (0x43)	'A' (0x41)	Space (0x20)	Input – 1st digit (0x30...0x32)	Input - 2nd digit (0x30...0x39)	<CR> (0x0D)

Response:

Byte 1	Byte 2
'*' (0x2A)	<CR> (0x0D)

This command connects all output ports to the specified input port.

SS_01- Enable Auto Status Mode

Command:

Byte 1	Byte 2	Byte 3	Byte 4	Byte 5	Byte 6
'S' (0x53)	'S' (0x53)	Space (0x20)	'0' (0x30)	'1' (0x31)	<CR> (0x0D)

Response:

Byte 1	Byte 2
'*' (0x2A)	<CR> (0x0D)

Auto status mode is disabled by default whenever the connection is established, and this command must be entered to enable it. When auto status mode is enabled, a message will be sent whenever an input/output connection changes from any source. The format of this message is given in the table below. The first two numeric digits are the output port number and the two after the colon are the number of the input port that is now connected to it.

Byte 1	Byte 2	Byte 3	Byte 4	Byte 5	Byte 6	Byte 7	Byte 8	Byte 9
'p' (0x70)	'c' (0x63)	Space (0x20)	Output – 1st digit (0x30...0x32)	Output – 2nd digit (0x30...0x39)	':' (0x3A)	Input – 1st digit (0x30...0x32)	Input – 2nd digit (0x30...0x39)	<CR> (0x0D)

SS_00- Disable Auto Status Mode

Command:

Byte 1	Byte 2	Byte 3	Byte 4	Byte 5	Byte 6
'S' (0x53)	'S' (0x53)	Space (0x20)	'0' (0x30)	'0' (0x30)	<CR> (0x0D)

Response:

Byte 1	Byte 2
'*' (0x2A)	<CR> (0x0D)

This command disables auto status mode.

SX- Examine connections

Command:

Byte 1	Byte 2	Byte 3
'S' (0x53)	'X' (0x58)	<CR> (0x0D)

Response:

Multiple lines, one line for each output:

Byte 1	Byte 2	Byte 3	Byte 4	Byte 5	Byte 6	Byte 7	Byte 8	Byte 9
'p' (0x70)	'c' (0x63)	Space (0x20)	Output – 1st digit (0x30...0x32)	Output – 2nd digit (0x30...0x39)	':' (0x3A)	Input – 1st digit (0x30...0x32)	Input – 2nd digit (0x30...0x39)	<CR> (0x0D)

Byte 1	Byte 2	Byte 3	Byte 4	Byte 5	Byte 6	Byte 7	Byte 8	Byte 9
'p' (0x70)	'c' (0x63)	Space (0x20)	Output – 1st digit (0x30...0x32)	Output – 2nd digit (0x30...0x39)	':' (0x3A)	Input – 1st digit (0x30...0x32)	Input – 2nd digit (0x30...0x39)	<CR> (0x0D)

Last line:

Byte 1	Byte 2
'*' (0x2A)	<CR> (0x0D)

AO-Read Audio Connection for Output Port

Command:

Byte 1	Byte 2	Byte 3	Byte 4	Byte 5	Byte 6
'A' (0x41)	'O' (0x4F)	Space (0x20)	Output – first digit (0x30...0x32)	Output – second digit (0x30...0x39)	<CR> (0x0D)

Response:

Byte 1	Byte 2	Byte 3	Byte 4	Byte 5	Byte 6	Byte 7	Byte 8	Byte 9
'a' (0x41)	'c' (0x63)	Space (0x20)	Output – 1st digit (0x30...0x32)	Output – 2nd digit (0x30...0x39)	',' (0x2C)	Input – 1st digit (0x30...0x32)	Input – 2nd digit (0x30...0x39)	<CR> (0x0D)

This command will read the connection of the desired audio output port. The response returns the audio input port that is connected to that audio output port.

AS-Connect Audio Output Port to Input Port

Command:

Byte 1	Byte 2	Byte 3	Byte 4	Byte 5	Byte 6	Byte 7	Byte 8	Byte 9
'A' (0x41)	'S' (0x53)	Space (0x20)	Input – 1st digit (0x30...0x32)	Input – 2nd digit (0x30...0x39)	',' (0x2C)	Output – 1st digit (0x30...0x32)	Output – 2nd digit (0x30...0x39)	<CR> (0x0D)

Response:

Byte 1	Byte 2
'*' (0x2A)	<CR> (0x0D)

This command connects the specified audio input port to the specified audio output port.

AA-Connect All Audio Outputs to Input Port

Command:

Byte 1	Byte 2	Byte 3	Byte 4	Byte 5	Byte 6
'A' (0x41)	'A' (0x41)	Space (0x20)	Input – first digit (0x30...0x32)	Input – second digit (0x30...0x39)	<CR> (0x0D)

Response:

Byte 1	Byte 2
'*' (0x2A)	<CR> (0x0D)

This command connects all audio output ports to the specified audio input port.

AV- Set Audio Volume for Output Port

Command:

Byte 1	Byte 2	Byte 3	Byte 4	Byte 5	Byte 6	Byte 7	Byte 8	Byte 9
'A' (0x41)	'V' (0x65)	Space (0x20)	Output – 1st digit (0x30...0x32)	Output – 2nd digit (0x30...0x39)	',' (0x2C)	Volume – 1st digit (0x30...0x32)	Volume – 2nd digit (0x30...0x39)	<CR> (0x0D)

Response:

Byte 1	Byte 2
'*' (0x2A)	<CR> (0x0D)

This command sets the volume specified audio output port to the specified level (00 – 99).

AM- Mute/Unmute Audio Output Port

Command:

Byte 1	Byte 2	Byte 3	Byte 4	Byte 5	Byte 6	Byte 7	Byte 8	Byte 9
'A' (0x41)	'M' (0x4D)	Space (0x20)	Output – 1st digit (0x30...0x32)	Output – 2nd digit (0x30...0x39)	',' (0x2C)	'0' (0x30)	Mute Status (0x30 or 0x31)	<CR> (0x0D)

Response:

Byte 1	Byte 2
'*' (0x2A)	<CR> (0x0D)

This command sets or clears the mute status of the specified audio output port. A mute status of 00 indicates that the port is not muted, while a status of 01 indicates that the port is muted.

Terminate telnet session

Command:

Byte 1	Byte 2	Byte 3
'X' (0x58)	'X' (0x58)	<CR> (0x0D)

Response:

Byte 1	Byte 2
'*' (0x2A)	<CR> (0x0D)

The unit will respond with '*<CR>' and close the connection, terminating the telnet session. The unit is then available for future connections.

Web Interface

A user may control the connections of the VEEMUX using a Web Interface via any web browser (see page 1 for supported web browsers). With the VEEMUX connected to a LAN through an Ethernet cable, a user can access the web interface controls inside the VEEMUX.

FYI: To quickly locate a VEEMUX on the LAN and edit the IP address settings, use the Device Discovery Tool (page 48).

To access the web interface, type the current IP address into the address bar of the web browser.

Address

To open a SSL-encrypted connection, type:

Address

You will be prompted to accept a certificate. Accept the NTI certificate.

A "Login Page" will appear.

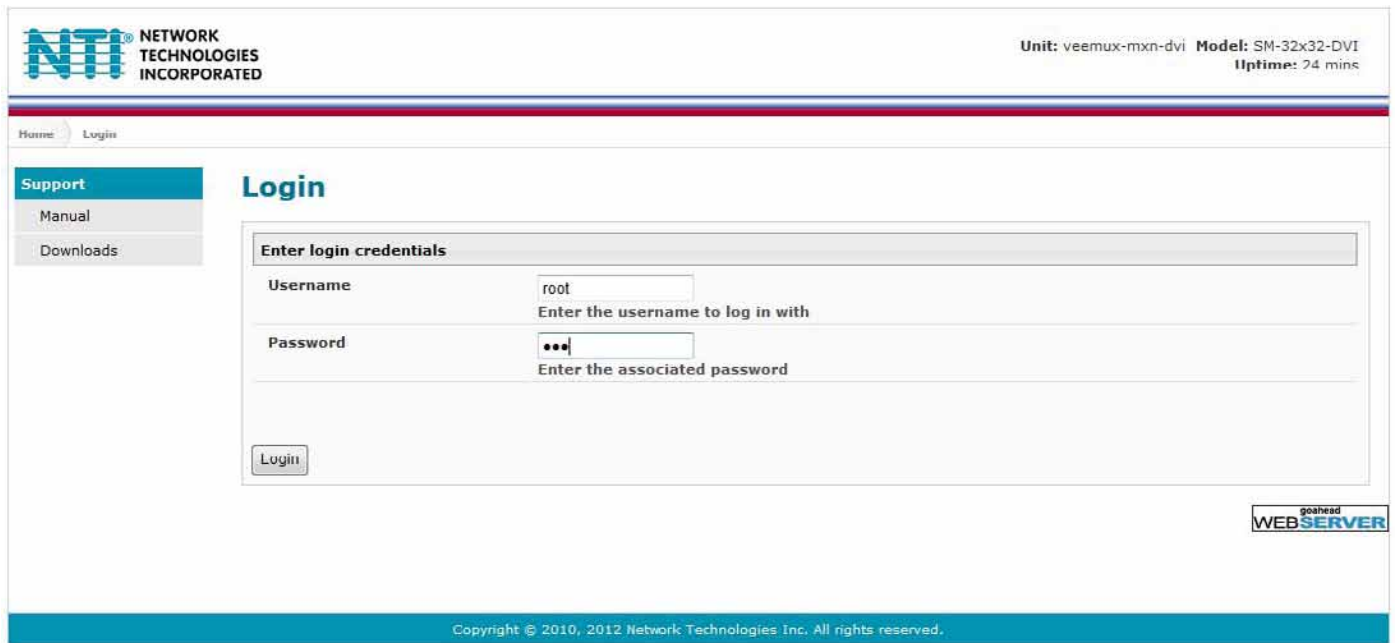

Figure 14- Web interface Login page

Enter the Password

The cursor will be flashing inside the username box. Enter the administrative username (this cannot be changed), then enter the default password:

User Name = root (lower case letters only)

Password = nti (lower case letters only)

To change the password, see page 40.

If you are not the "root" user, access to the VEEMUX may be limited. Contact the VEEMUX administrator for your individual username and password.

For information on setting up as many as 15 additional users, see page 40.

Note: The browser must be configured to accept cookies in order for the user to successfully make use of the web interface.

With a successful login, the main menu and Video Switch page will appear.

Main Menu

The VEEMUX main menu provides control over all functions of the switch. The administrative menu includes options not available to other users with limited privileges.



When logged in a user without administrative privileges, only the SWITCH, LOGOUT, and SUPPORT menu options will be available.

For more on user management, see page 40.

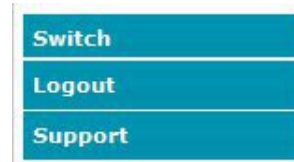

Figure 15- Administrator Menu

(User Main Menu)

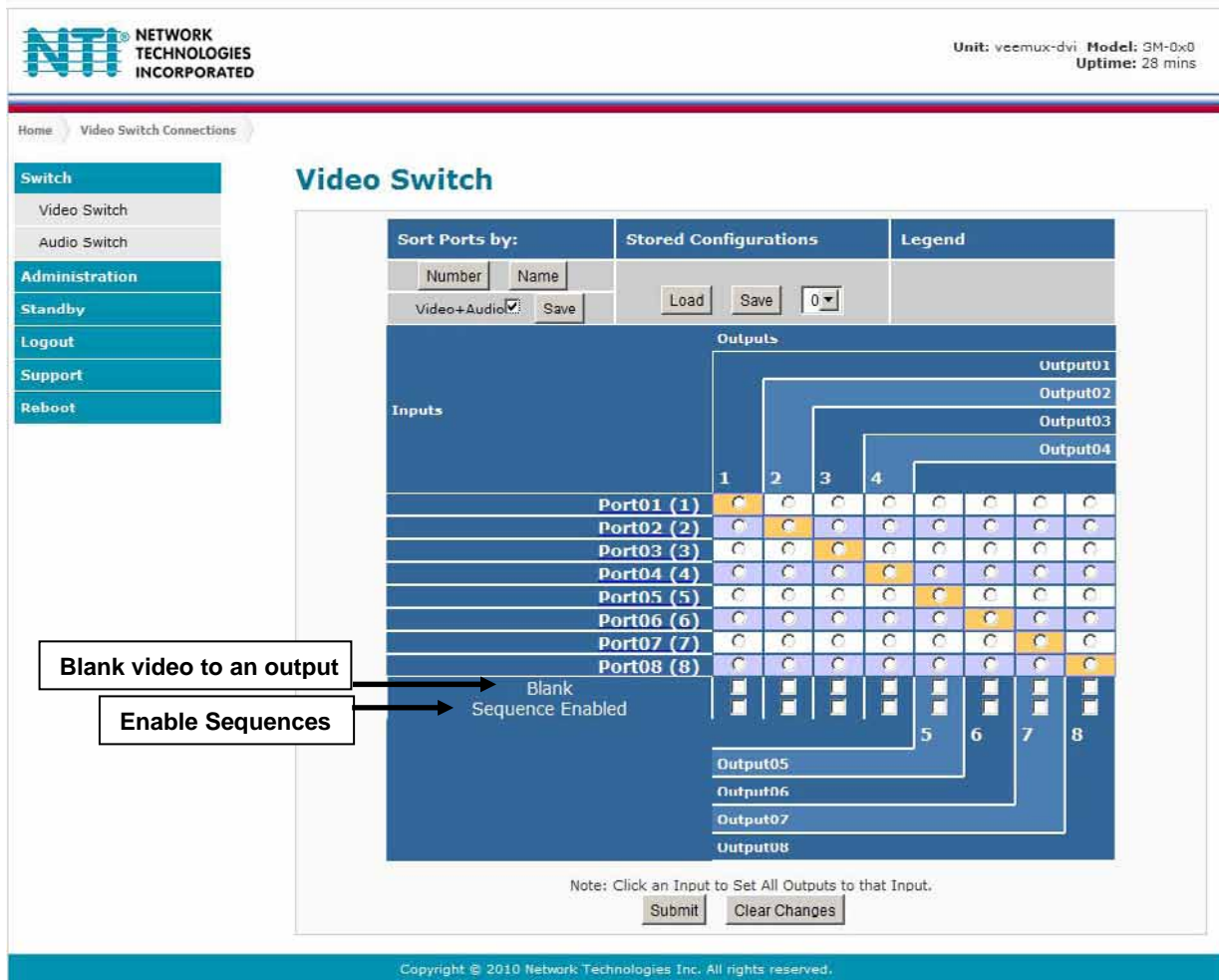

Figure 16- Main menu and Video Switch page

From the menu the administrative user can choose from several links to either view the status of the switch or change the configuration of it. As described on the following pages, each link will enable different areas of control.

Video Switch Page

The Video Switch page (Figure 16) displays the active connections (shown in orange) and enables the user to control the video connections of the VEEMUX. Up to 100 different connection configurations can be saved and later recalled by any connection method. Scanning Sequences (page 38) for each output can also be enabled.

Note: Changes made using the keypad (page 9) or by another user through the web interface will be updated automatically to your browser every 10 seconds.

Note: Configuration 0 will be automatically loaded when the VEEMUX is powered-up.

To change a connection, click on the radio button (square image with circle in the center) that intersects the input and output columns. A black dot will be placed in the circle to indicate the selection. Then press the **Submit** button. The display will be reloaded with the selections changed to orange to indicate they are now active. Multiple connections can be changed simultaneously.

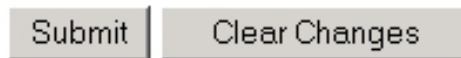

To quickly clear the selected radio buttons press the **Clear Changes** button. This will only work if the **Submit** button has not already been pressed with the selections made.

To quickly connect all outputs to a single input, click on the desired input.

FYI: See page 22 for an example of using the Outputs Scanning Sequences feature.

To save a configuraton, from the **Stored Configurations** user interface, use the drop-down list to select the desired slot (numbers 0-99) to save the active configuration into and press the **Save** button.

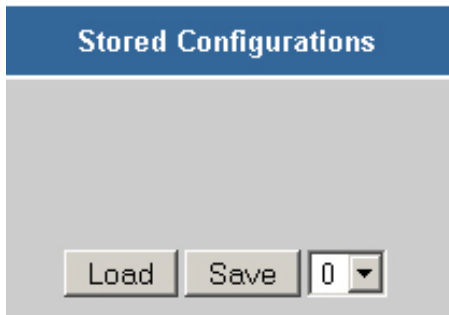

Note: This will save the currently active configuration on the VEEMUX and the DDC configuration (page 41). If changes have been made in the web interface without first pressing the **Submit** button, those changes will not yet be part of the active configuration.

Note: If changes to the active configuration have been made by another user prior to saving the current connection selections, the changes made by the other user will be saved as the configuration.

The webpage configuration that loads after a **Save** is the configuration that was actually saved.

To load a saved configuration, from the **Stored Configurations** user interface, use the drop-down list to select the desired configuration. Then press the **Load** button. The VEEMUX will make the connections and the screen will refresh to show the connections associated with that configuration selection. This also loads the saved DDC configuration (page 41).

To blank the video to a specific output, click the box to the right of “Blank” that corresponds with the desired output to place a checkmark in it. The video going to that output will be disabled.

To enable the scanning sequence configured for an output, configure the automatic scanning sequence of inputs that should be viewed at the output (see page 38) and then click the box to the right of “Sequence Enabled” that corresponds with the desired output to place a checkmark in it. The video viewed from that output will switch from input to input according to the configured sequence.

Administration

Switch
Administration
System
Network
Video Input Names
Video Output Names
Scanning Sequence
User Config
DDC Options
DDC Mix Settings
Firmware
Standby
Logout
Support
Reboot

The Administration section provides links to pages for all configuration options in the VEEMUX switch. Only the user ROOT and users with administrative privileges have access to this section. The administration section is broken up into 10 topics:

System	Assign the switch name and serial port communication settings
Network	Assign all network settings for connection to LAN
Video Input Names	Assign port names to each cable connection from video sources for easy reference
Video Output Names	Assign port names to each cable connection from display devices for easy reference
Scanning Sequence	Assign dwell times for each input as it is assigned to each output's scanning sequence
User Config	Add, edit, and delete users and control user privileges
DDC Options	Configure how each input will receive EDID information
DDC Mix	Select outputs/displays to be used for EDID mixing for each input
Video Optimization	Fine tune the video quality viewed on a monitor (not applicable to 8X8 model)
Firmware	Update the firmware as new versions become available

System Configuration

On the System Configuration page, under Administration, fields are provided to assign a unique name to the VEEMUX, set the baud rate for serial communications, and the serial address to be used in RS232 commands.

After applying the desired settings, press **“Save”** to finish.

System Configuration

The screenshot shows the 'System Configuration' web interface. It is divided into several sections:

- Unit Settings:** Includes a 'Name' field with the value 'VEEMUX-000-001' and a sub-label 'Unique name for this unit'.
- Serial Port Settings:** Includes a 'Baud Rate' dropdown set to '9600 bps' with a sub-label 'Baud Rate for RS232 Commands', and a 'Serial Address' dropdown set to '1' with a sub-label 'Address for RS232 Commands and System Address for IR Remote'.
- Configuration Backup & Restore:** Includes a 'Choose File' field with a 'Browse...' button and a note: 'Choose configuration file to restore. Note: system will reboot to apply the configuration.'
- At the bottom, there are buttons for 'Upload Config', 'Download Configuration File', 'Restore Defaults', and 'Save'.

Figure 17- System Configuration page

(Applicable to models 4x4, 16x16, and 32x32 only)

Download Configuration File - To save VEEMUX configuration and DDC settings for a future reload or to save time in configuring multiple VEEMUX switches, the configuration file for the VEEMUX can be downloaded to your PC using **“Configuration Backup & Restore”**. Click on **“Download Configuration File”** to save the VEEMUX configuration to your PC.

From your PC the downloaded configuration file can be edited using any text editor or html editor. Using an editor you can change settings, change IP address, etc. and then upload the result into an additional VEEMUX switch to save time.

Upload Config- Click on the **Browse** button to browse to the file, click on **“Upload Config”**, and restore the VEEMUX to the configuration stored in the uploaded file.

Restore Defaults- Click on **“Restore Defaults”** to remove all user-configured settings and restore the VEEMUX to a factory default configuration.

Note: Before restoring defaults, we recommend you download the existing configuration file to your PC.

Network Configuration

ON the Network Configuration page, under Administration, the administrative user can configure the VEEMUX web interface connection. This will provide access to control of the VEEMUX from any web-accessible computer.

Network Configuration

The screenshot displays the Network Configuration page with two main sections: IP Settings and Server Settings. In the IP Settings section, the Mode dropdown menu is open, showing options: Static, DHCP, Static, and Disable. The Mode field is currently set to Static. Below the Mode field, there are input fields for IP Address (192.168.3.61), Subnet Mask (255.255.255.0), Default Gateway (192.168.3.3), Preferred DNS, and Alternate DNS. The Server Settings section includes checkboxes for Enable Telnet and Allow HTTP Access, and input fields for HTTP Port (80), HTTPS Port (443), and Web Timeout (600). A Save button is located at the bottom left of the form.

Figure 18- Network Configuration page

Mode – Choose between Static IP assignment, DHCP (dynamic IP assignment) or Disable the Ethernet port entirely.

IP Address- If using Static IP assignment, enter a valid IP address to use

Subnet Mask- Enter a valid subnet mask value

Default Gateway- Enter a valid gateway address

Preferred DNS- Enter a valid Domain Name Server address (not required)

Alternate DNS- Enter a valid alternate Domain Name Server address if desired (not required)

This change will take a few seconds and automatically redirect the user to the IP address specified.

If telnet is going to be used to control the VEEMUX, place a checkmark in the “Enable Telnet” block.

If you wish to disable non-secure web access to the VEEMUX, remove the checkmark from “Allow HTTP Access”. With this box empty, only secure shell web access will be allowed.

A standard port number can be assigned for the HTTP (non-secure) and HTTPS (secure) ports, numbers ranging from 0-65535. Default HTTP port is 80, and default HTTPS port is 443.

The Website Timeout option controls how long an inactive web connection will stay logged in. The range is 0-3200 minutes (0 disables it). Any change to the Website Timeout configuration takes effect immediately.

Press the “**Save**” button to save any changes made.

Video Input Names

From the Administration menu, the Video Input Names page can be displayed. This page enables the administrative user to change the name of the input ports displayed on the Video Switch page.

Video Input Names

Video Input Names	
Port1.	<input type="text" value="Port01"/> Name for input port 1
Port2.	<input type="text" value="Port02"/> Name for input port 2
Port3.	<input type="text" value="Port03"/> Name for input port 3
Port4.	<input type="text" value="Port04"/> Name for input port 4
Port5.	<input type="text" value="Port05"/> Name for input port 5
Port6.	<input type="text" value="Port06"/> Name for input port 6
Port7.	<input type="text" value="Port07"/> Name for input port 7
Port8.	<input type="text" value="Port08"/> Name for input port 8

Figure 19- Video Input Names page

To change an Input Name, enter the name of the port for the desired input port number, and press “**Save**”.

If you make changes and change your mind and want to return the names back to what they were before changing them, press “**Reset**”. This must be done before pressing the “**Save**” button, or changes will not be able to be reversed.

Video Output Names

From the Administration menu, the Output Names page can be displayed. This page enables the Administrator to change the names of the output ports displayed on the Switch page.

Video Output Names

Video Output Names	
User1.	<input type="text" value="Output01"/> Name for output port 1
User2.	<input type="text" value="Output02"/> Name for output port 2
User3.	<input type="text" value="Output03"/> Name for output port 3
User4.	<input type="text" value="Output04"/> Name for output port 4
User5.	<input type="text" value="Output05"/> Name for output port 5
User6.	<input type="text" value="Output06"/> Name for output port 6
User7.	<input type="text" value="Output07"/> Name for output port 7
User8.	<input type="text" value="Output08"/> Name for output port 8

Copyright © 2010, 2012 Network Technologies Inc. All rights reserved.

Figure 20- Video Output Names page

To change an Output Name, enter the name of the port for the desired output port number, and press "**Save**".

If you make changes and change your mind and want to return the names back to what they were before changing them, press "**Reset**". This must be done before pressing the "**Save**" button, or changes will not be able to be reversed.

Scanning Sequences

From the Administration menu, the Scanning Sequence page can be displayed. The Scanning Sequence page displays the configuration of an automatic switching sequence from input (video source) to input for each output (monitor).

The page displays:

- output number being configured
- the Scanning Sequence function status for that output
- the length of time in seconds (dwell time) that each input will be viewed when connected- the dwell time value ranges from 0-32000 seconds

Scanning Sequence

Scanning Sequence

Dwell Times for output: Output01 (1) ▼

Sequence Enabled

Input	Dwell time (seconds)
Port01 (1)	<input style="width: 100%;" type="text" value="0"/> <small>Scan dwell time for input 1 - (0-255)seconds. 0=disable scan.</small>
Port02 (2)	<input style="width: 100%;" type="text" value="0"/> <small>Scan dwell time for input 2 - (0-255)seconds. 0=disable scan.</small>
Port03 (3)	<input style="width: 100%;" type="text" value="0"/> <small>Scan dwell time for input 3 - (0-255)seconds. 0=disable scan.</small>
Port04 (4)	<input style="width: 100%;" type="text" value="0"/> <small>Scan dwell time for input 4 - (0-255)seconds. 0=disable scan.</small>
Port05 (5)	<input style="width: 100%;" type="text" value="0"/> <small>Scan dwell time for input 5 - (0-255)seconds. 0=disable scan.</small>
Port06 (6)	<input style="width: 100%;" type="text" value="0"/> <small>Scan dwell time for input 6 - (0-255)seconds. 0=disable scan.</small>
Port07 (7)	<input style="width: 100%;" type="text" value="0"/> <small>Scan dwell time for input 7 - (0-255)seconds. 0=disable scan.</small>
Port08 (8)	<input style="width: 100%;" type="text" value="0"/> <small>Scan dwell time for input 8 - (0-255)seconds. 0=disable scan.</small>

Copyright © 2010, 2012 Network Technologies Inc. All rights reserved.

Figure 21- Scanning Sequence page

The output selection at the top of the page can be changed to any output to display the Scan Sequence Input dwell time values for that output.

The inputs and the amount of time that each will be viewed (0-32000 seconds) can be set to cycle sequentially for each connected output. If an input is set to 0 seconds, that input will not be viewed and will be skipped from the scanning sequence. To include an input in the sequence, enter a dwell time period from 1-32000 seconds, and press **“Save”**.

If you make changes and change your mind and want to return the values back to what they were before changing them, press **“Reset”**. This must be done before pressing the **“Save”** button, or changes will not be able to be reversed.

To enable the scanning sequence for the output shown, place a checkmark in the “Sequence Enabled” block.

Tip: To quickly enable the scan sequence for multiple outputs, use the “Sequence Enable” blocks found on the Switch Page (page 18).

Note: If only one input has a dwell time value entered, then the output connection to that input will not end when the Scanning Sequence is enabled.

User Config

From the Administration menu, select the User Config to display a list of the users that have been configured on the VEEMUX.

- To add a user, select “Add New User”.
- To change the configuration of a user, select the Username, or “Edit”.
- To delete a user, select “Delete” for that user.

Users

Users				
Num.	Username	Enabled	Admin	Action
1	root	yes	yes	Edit
2	user1	yes	no	Edit Delete

[Add New User](#)

Figure 22- Users page

Whether you add a user, or edit a user, the “Configure User” page will open. If this is a new user being added, enter a user name, decide if the user should have administrative privileges or not, enable their access to the VEEMUX (or not), and assign a password.

- Usernames and passwords are case sensitive.
- Usernames can be from 1 to 16 characters in length and can be alphabetical or numeric.
- Passwords can be from 5 to 16 characters in length and can be alphabetical or numeric.

Note: A password must be entered for the user to be enabled, even if the “Enable” block is checked and the user is saved without a valid password being entered.

Configure User

Account Settings

Username	<input type="text" value="user1"/> <small>The username for this user</small>
Admin	<input type="checkbox"/> <small>Grant this user administrative privileges</small>
Enabled	<input checked="" type="checkbox"/> <small>Users can only access the system if their account is enabled</small>
Password	<input type="password" value="••••••"/> <small>The user's password to login to the system (for local authentication)</small>
Confirm	<input type="password" value="••••••"/> <small>Confirm the entered password</small>
Title	<input type="text"/> <small>The user's title within the company</small>
Department	<input type="text"/> <small>The user's department within the company</small>
Company	<input type="text"/> <small>The name of the user's company</small>

Figure 23- User configuration page

After making any changes, be sure to click “Save”.

DDC Options

From the Administration menu, the DDC Options page can be displayed. DDC enables the video source to get EDID information from the display device. This enables the video source to automatically select the optimal resolution for the display by receiving, at power up, information from the display device concerning its resolution specifications.

DDC Options

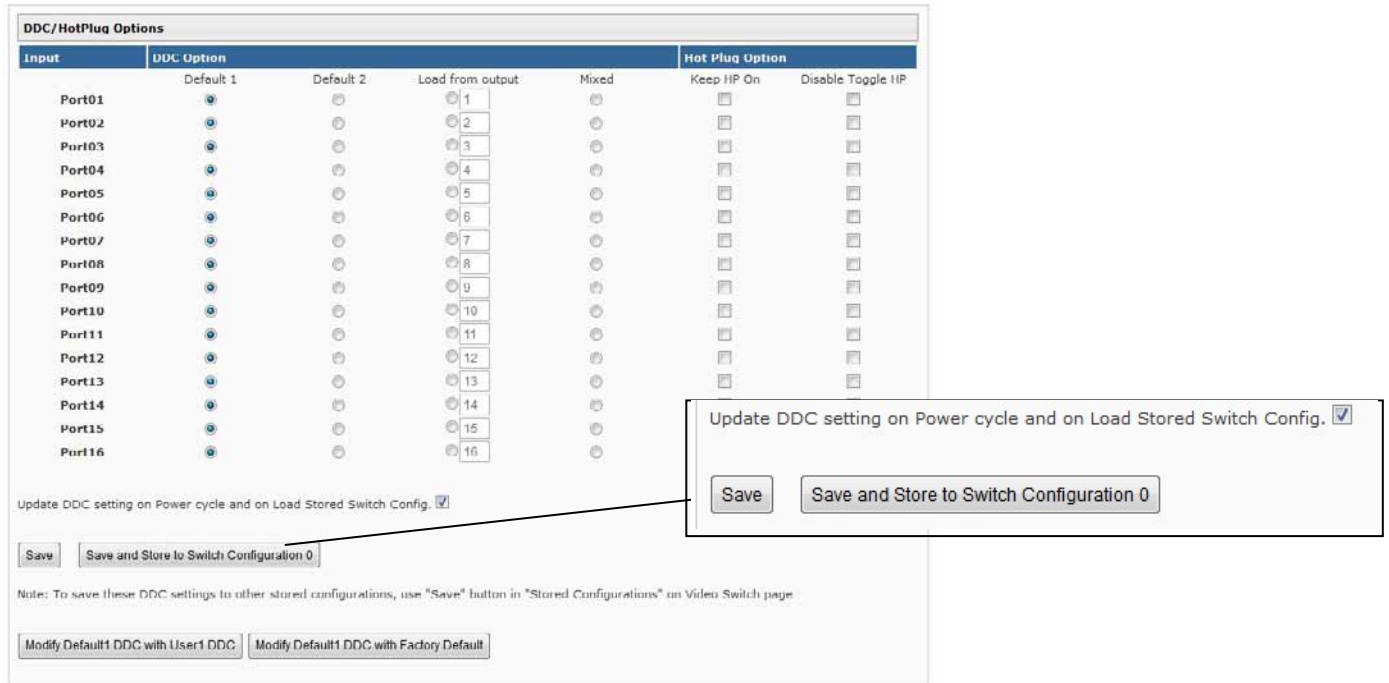

Figure 24- DDC Options page

EDID information can be provided to the video source by the VEEMUX as follows:

Default1- The video source on the input port will receive EDID information from the VEEMUX through an onboard table of values. The values for Default 1 support computer monitors.

Default2- The video source on the input port will receive EDID information from the VEEMUX through an onboard table of values. The values for Default 2 support televisions.

Load from Output- select the radio button for this option and enter the output number associated with the monitor that the CPU should get its EDID information from.

Direct- (available in 4x4 and 8x8 models only) The video source on an input will get EDID information from the video display device that is first connected to the output, regardless of what other display devices are also connected to the video source. If the first output is switched to another input, the video source will look to the other connected outputs to get EDID information from, searching from the lowest numbered output port first.

For example: The video source on input 1 is connected to output 8, then 4, then 2, and then 5 for a total of 4 display connections. If output 8 is switched to another video source, the video source on input 1 will then get EDID information from output 2.

Mixed- The video source on the input port will receive EDID information that is common to the outputs selected on the “DDC Mix” page (page 42) for that input.

Update DDC setting on Power cycle and on Load Stored Switch Config- place a checkmark in the box to refresh DDC data stored in the VEEMUX each time the VEEMUX is power-cycled or when a stored configuration (page 33) that includes this DDC configuration is loaded. The DDC data will be updated based on the configuration on this page.

Save and Store to Switch Configuration 0- press to save the DDC Configuration settings to Switch Configuration 0 so that when the VEEMUX is power cycled and the “Update DDC setting on Power Cycle...” (above) is checked, the DDC Configuration will be loaded as configured above.

Modify Default1 DDC with User1 DDC- click this button to load the EDID information to “Default1” from the video display connected to Output 1

Modify Default1 DDC with Factory Default- click this button to restore “Default1” with factory supplied EDID information

Once any changes are made, press “**Save**” to have them take effect.

Notes:

1. *A Blu-Ray player, and any other video source with protected content, must use "Direct" DDC option and can be connected to only one output port at a time.*
2. *In order for the video sources to correctly receive the EDID information from the switch at boot-up, the switch must be powered-up before all attached video sources.*
3. *If "Disable Toggle HP" is checked for any Input port, the changes made for that port will not take immediate effect when "Save" is pressed.*

Hot Plug Options

The DVI video standard includes the ability for the DVI monitor to automatically send EDID information to the video source when the DVI cable is disconnected and re-connected, or "Hot Plugged".

The DDC Options page includes the option to maintain a "monitor connected" signal to the video source to prevent the source from going to sleep if the display device is actually disconnected from the VEEMUX. To maintain this signal, place a checkmark in the box for "Keep HP On" for the associated Input Port (Figure 24).

Under normal circumstances, a PC that is powered-ON without having an active (output with display attached) DVI output port connection would switch to the default output mode (normally VGA) because the PC would not detect the presence of a DVI display. This can be avoided by checking "Keep HP On" for that Input port. This allows the switch to signal the PC as if a DVI display was connected triggering the PC to output video on its DVI output.

The DDC Option page also provides the option to maintain a "monitor connected" signal when the VEEMUX is scanning from one display device to another. Normally the "monitor connected" signal would toggle from On to Off and back to On when the VEEMUX switches from display device to the next. To prevent this toggling and maintain the signal as On, place a checkmark in the "Disable Toggle HP" for the associated Input Port (Figure 24).

Note: If the "Disable Toggle HP" is checked for an Input port and the EDID information source for an Input port is switched from one display or source to another, the Input port will not update the EDID information from the new display/source.

DDC Mix

From the Administration menu, the DDC Mix page can be displayed. DDC Mix provides a means to decide which outputs (displays) will be used to provide EDID information to the selected input. The VEEMUX will compare EDID information from all selected outputs and provide EDID information that is common to those displays to the video source. If the "Mixed" option is desired for an input on the "DDC Options" page (page 41), settings of the DDC Mix for that input (below) should be selected and saved first.

If the DDC Mix configuration for an input is not configured and the "Mixed" option for the input is selected on the DDC Options page, a minimal default collection of EDID information will be provided to the video source.

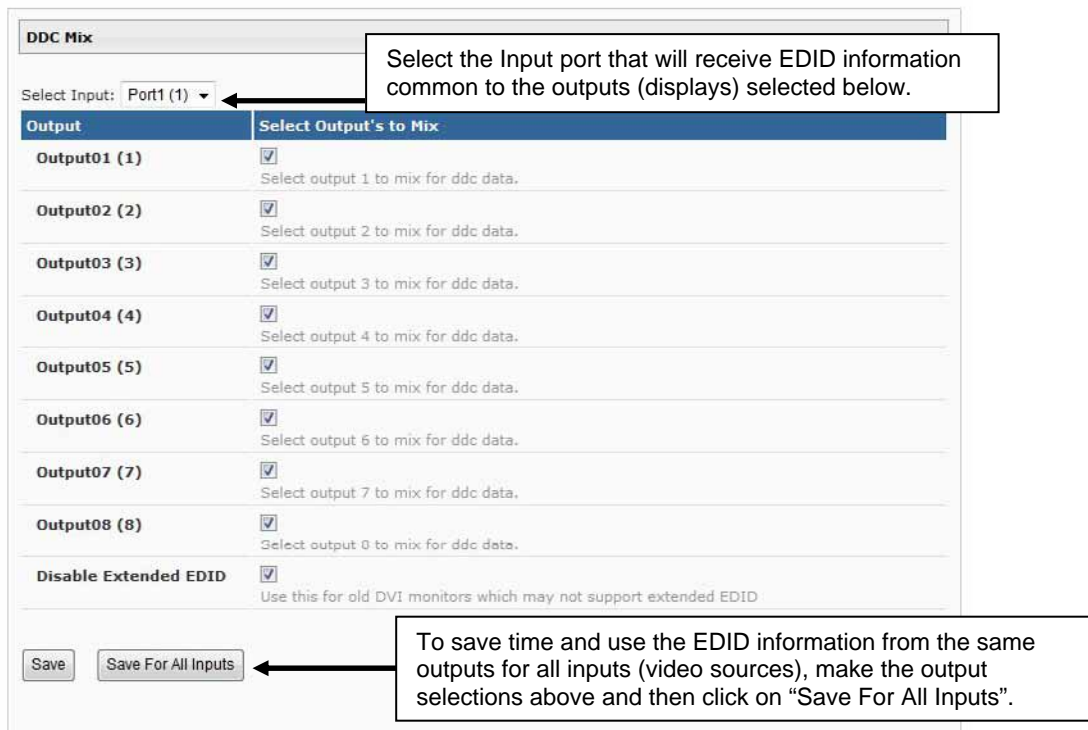

Figure 25- DDC Mix page

Video Optimization

(Applicable to models 4x4, 16x16, and 32x32 only) From the Administration menu, the Video Optimization page can be displayed. This page enables the administrator to improve the video quality of a PC (input) as viewed on a monitor (output).

Video Optimization

Video Adjustment		
Output No.	Connected Input	Optimize Video
1	1	< 28 >
2	2	< 27 >
3	3	< 27 >
4	4	< 27 >
5	5	< 27 >
6	6	< 27 >
7	7	< 27 >
8	8	< 27 >

Note: *It is not recommended that the user change the video quality of a connection while in the web interface on that connection. Changing the Optimize Video values of the connection while in the web interface could result in a loss of video on that monitor and the inability to complete the task without logging into the VEEMUX from another PC.*

Figure 26- Video Optimization page

If video quality is poor, press the left arrow or right arrow adjacent to the corresponding connection to increase or decrease the video quality value (default is 27).

Update Firmware

From the Administration menu, the Update Firmware page can be displayed. The Update Firmware page shows the current version of the firmware and enables the Administrator to update the firmware to the latest version available.

Update Firmware

Figure 27- Update Firmware page

WARNING: Failure to carefully follow these directions can permanently damage the VEEMUX. Please read these directions in full before continuing. Do not, under any circumstances, reset or power-down the VEEMUX while the firmware is being updated. Do not attempt to update the firmware if a power-failure is likely.

Note: The Firmware can only be updated from the non-secure (http) website. If you attempt to access this page from the secure (https) website, you will be automatically redirected to the non-secure site.

To update the firmware:

1. Contact NTI for the latest firmware file name `veemux-dvi-vx-x.bin` (where x.x is the version number) and copy it to your computer.
2. On the Update Firmware page, in the "Update File" block, browse to the firmware file.
3. Press **Upgrade**.

Note: If an update is attempted using the wrong firmware for the section an error message will be received. No update will occur.

4. The VEEMUX will upload the firmware and then restart itself (this may take up to 4 minutes), logging out all connections. After the restart, approximately 4 more minutes, the VEEMUX will be ready to resume operation.

If a message appears stating that the Upload has failed, or that a non-fatal error has occurred:

1. Ensure that the file being uploaded is the NTI firmware file.
2. Repeat the process from step 2 above.

Note: The following message does not indicate that damage to the product has occurred.

If a message appears stating that there has been a fatal error:

1. **DO NOT RESET OR POWER-DOWN THE VEEMUX.**
2. Repeat the update process from the first step 2 above.
3. If you get another Fatal Error message, call NTI tech-support at 1-800-742-8324 or 330-562-7070.

FYI: The VEEMUX should continue to run normally unless it is reset. However, damage may have occurred to the web server firmware that will prevent the product from starting up correctly.

Standby Mode

From the menu, the user can quickly place the VEEMUX in Standby Mode. When in Standby, the VEEMUX will still be powered-ON but all functions will stop. The VEEMUX will be in a power-saving ready-to-use state.

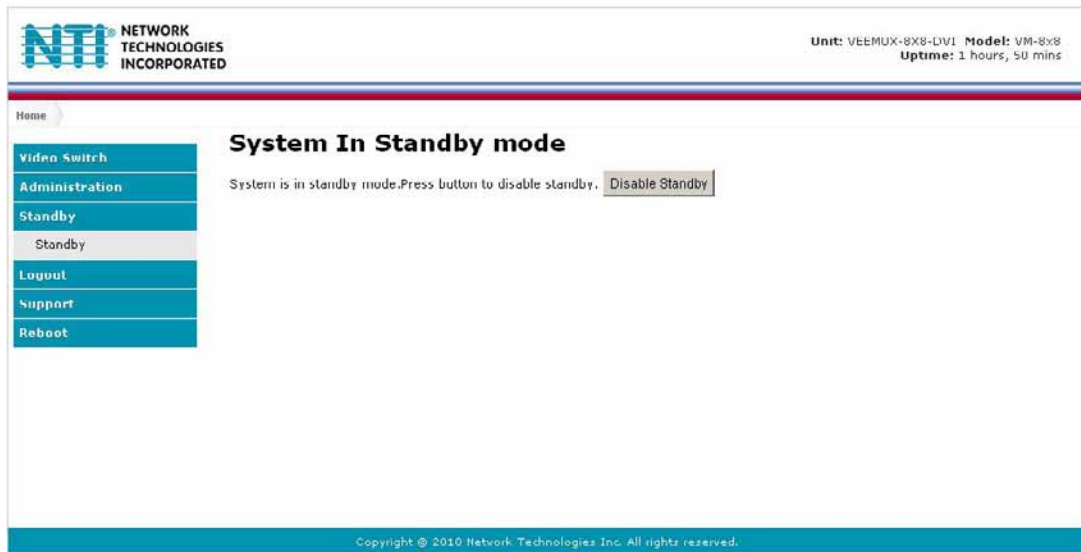

Figure 28- VEEMUX in Standby Mode

By simply selecting “Standby” from the side menu, the VEEMUX is placed in Standby Mode. When in Standby Mode, the VEEMUX will not provide video to any displays and cannot be manipulated further until standby is disabled.

Standby Mode can be disabled either
 by pressing “Disable Standby” through the web interface (above),
 by pressing any button on the front panel keypad
 by using the IR Remote control (optional)

Logout

To quickly logout of the web interface, select “Logout” from the menu. You will immediately be logged out and presented with a login screen.

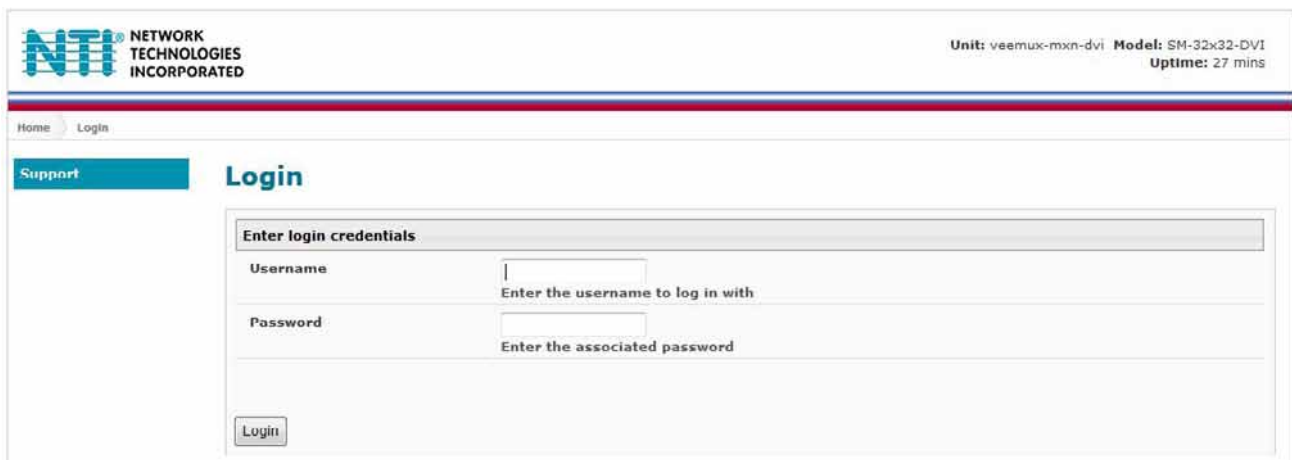

Figure 29- Logout of the VEEMUX web interface

Support

The Support link on the menu drops down to two choices, **Manual** and **Downloads**.

The **Manual** link will open the pdf manual for the VEEMUX.

The **Downloads** link will open the firmware downloads page for the SM-8X8-DVI Video Matrix Switch at NTI. From there you can see what versions of firmware are available and determine if the version in your VEEMUX is current or in need of an upgrade (page 44).

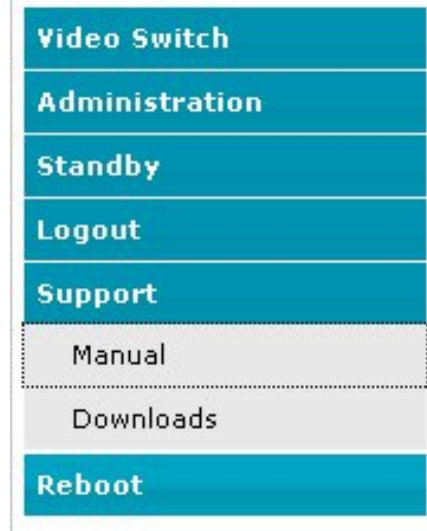

Figure 30- Support Tab

Reboot

To quickly reboot the VEEMUX, select “Reboot” from the side menu. This will force the VEEMUX to power cycle its processor. A reboot will take approximately 45 seconds to occur. Refresh your browser and log back in to the VEEMUX as desired.

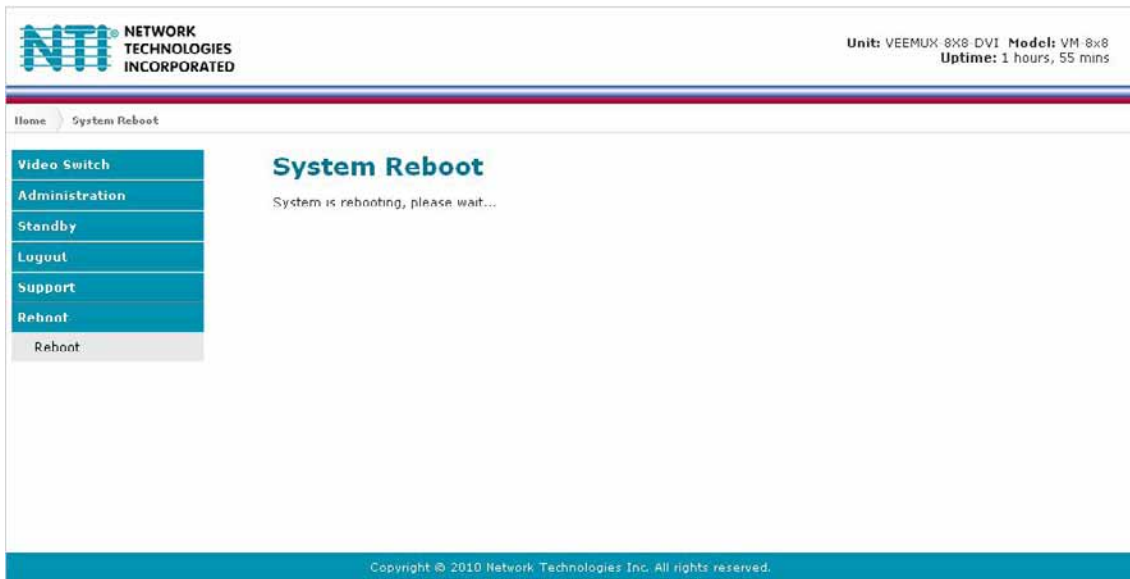

Figure 31- System Reboot

Web Interface With Audio Support

Models with audio support have additional control built in. An additional web page is provided to separately control audio connections if so desired.

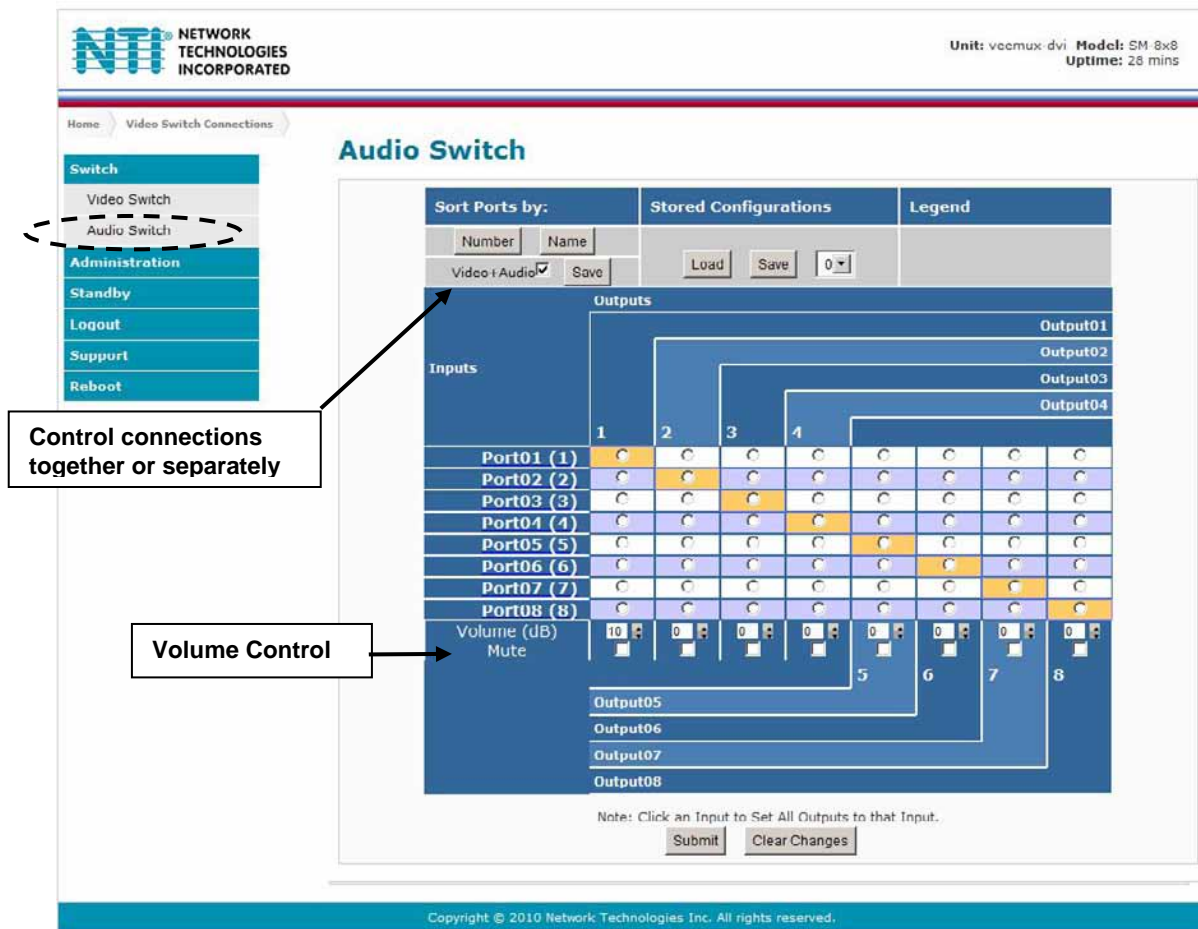

Figure 32- Audio Switch page

There is a checkbox provided that allows the user to choose between controlling audio along with video connections, or controlling them separately.

Place a checkmark in the “Video+Audio” box and press “**Save**” if you wish to control video and audio connections together. Remove the checkmark and press “**Save**” to control them separately.



Each output port has separate volume control as well. Enter the decibel (dB) level desired and press “Submit”. The audio for each port can also be muted.



If the optional Infrared Control has been purchased, audio connections can be controlled with a handheld remote infrared control from up to 30 feet away (see page 49).

DEVICE DISCOVERY TOOL

In order to easily locate the VEEMUX on a network, or to change network settings, the NTI Device Discovery Tool may be used. A link to the Discovery Tool is provided on the web page that appears when you insert the instruction manual CD provided into your CD ROM drive. Click on the link or browse the CD and click on the file *discover.html*. This will open your browser and display the Device Discovery Tool page.

Note: The Discovery Tool requires the Java Runtime Environment to operate. A copy of Java and a link to the web page from which it can be downloaded and installed is provided on the CD.

Note: The computer using the Discovery Tool and the VEEMUX must be connected to the same physical network in order for the Device Discovery Tool to work.

Network Technologies Inc Device Discovery Tool

- **START**
 - When you load this page, the NTI Device Discovery Applet should load. Accept the Certificate to allow this applet access to your network. Press the button entitled **Detect NTI Devices** to start the discovery process. After a short time, the tool will display all NTI devices on your network, along with their network settings.

Note: Do not close this page while the NTI Discovery Tool is running. Close the NTI Device Discovery Application first, **then** this webpage.
- **How To Use the Discovery Tool**
 - **To Change A Device's Settings**, within the row of the device whose setting you wish to change, type in a new setting and press the **Enter** key or the **Submit** button on that row. You can also press the **Submit All** button to submit all changes at once.
 - **To Refresh the list of devices**, press the **Refresh** button.
 - **To Blink the LEDs of the unit**, press the **Blink LED** button (This feature not supported on all products). The **Blink LED** button will change to a **Blinking...** button. The LEDs of the unit will blink until the **Blinking...** button is pressed, or the NTI Device Discovery Application is closed. The LEDs will automatically cease blinking after 2 hours.
 - **To Stop the LEDs of the unit blinking**, press the **Blinking...** button. The **Blinking...** button will change to a **Blink LED** button.

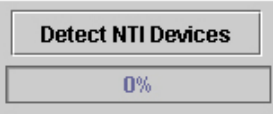

Figure 33- Device Discovery Tool page

Use the Device Discovery Tool to display all NTI VEEMUXs on your network, along with their network settings. Follow the instructions on the Device Discovery Tool page to use the tool and to change the device settings if so desired.

Device	MAC Address	IP Address	Mask	Gateway		
VEEMUX	00:40:9D:24:07:70	65.243.248.18	255.255.255.128	65.243.248.1	Submit	Blink LED
		Submit All	Refresh	Close		

The "Blink LED" button is not supported on the 8x8 model.

INFRARED REMOTE CONTROL

The IRT-UNV Infrared Remote Control allows the user to remotely and intuitively control up to 15 NTI SM-nXm-DVI(A)-LCD DVI video matrix switches, providing the ability to route connections, save and recall switch configurations, and put the switch into Standby.

Features:

- Routing of video and audio signals together or individually
- Ability to switch one input to all outputs
- Scroll through inputs for a single output by using the Input +/- keys (similar to changing channels)
- Automatically scan through all channels for a single output
- Save or Recall up to 10 matrix switch preset configurations
- Control up to 15 NTI switches (systems) with a single remote
- Put the switch in Standby

Materials

Materials supplied with the IRT-UNV:

- NTI IRT-UNV Infrared Remote Control
- 2- AAA Batteries (installed)

Buttons

The IRT-UNV Infrared Remote Control user interface consists of a keypad with 29 buttons. The buttons have the following functions:



- **Numerical Values (0-9)**
 - Selects port numbers (for IN, OUT)
 - Selects memory locations (for saved configurations)
- *** (Asterisk)**
 - Pressed to select all outputs
- **OUT**
 - Pressed to indicate an output port selection
- **IN**
 - Pressed to indicate an input port selection
- **IN +/-**
 - Cycles through input ports (up or down), connecting to each one (similar to changing channels)

Note: This affects only the selected output port

- **SAVE**
 - Pressed to save the current switch configuration (port connections and volume settings)
 - Up to 10 configurations can be saved (0-9)
- **RECALL**
 - Pressed to recall a switch configuration (port connections and volume settings)
 - Up to 10 configuration can be recalled (0-9)
- **SYS**
 - Pressed to select the desired NTI system to be controlled
 - Only used when controlling multiple systems
 - Must be followed by a system number: 1-15
- **ENTER**
 - Pressed to immediately accept the command (normal delay is approx. 5 seconds).
- **ESC**
 - Pressed to cancel the current command



Note: If the command has not yet been accepted, all button presses in the command sequence will be cleared

- **Standby** 

Pressed to put the unit into or out of standby mode
- **VIDEO** 
 - Pressed prior to entering a port switch command
 - Applies the command to the video signals only
 - (by default, port switch commands are applied to both Audio and Video)
- **BLANK Video** 
 - Turns OFF Video for the selected output
 - Can be used with *(Asterisk button) to turn OFF video for all outputs
 - Video will be turned ON by pressing the Blank Video button again, or by switching ports

Note: Blank and Un-Blank commands are applied only to the selected output



- **AUDIO**  **(Applies to models with audio support only)**
 - Pressed prior to entering a port switch command
 - Applies the command to the audio signals only
(by default, port switch commands are applied to both Audio and Video)
- **VOL +/-** **(Applies to models with audio support only)**
 - Increases / Decreases the volume for the selected output
 - Can be used with * (All) to adjust the volume for all outputs
 - "Volume +" and "Volume -" will operate as multi-press buttons – if continually held down, the volume will continue to increase / decrease.
- **MUTE Audio**  **(Applies to models with audio support only)**
 - Mutes audio for the selected output
 - Can be used with *(All) to mute all outputs
 - Audio will be un-muted by pressing the MUTE Audio button again, Increasing or Decreasing the volume, or by switching ports
 - Mute and Un-Mute commands are applied only to the selected output
- **SCAN**
 - Pressed to toggle the scan enable/disable feature for the selected port
 - Must be preceded by an output port number (1 or 2 digits), or the * (Asterisk) button to toggle all ports

Note: If the dwell time for a port is set for 0 seconds, it will not be scanned (page 38)
- **PREV -THIS BUTTON IS NOT USED FOR THIS PRODUCT**

Operation

Operation of the IRT-UNV is intuitive. The number of button presses required to complete any operation is kept to a minimum. This is accomplished using intelligent software within the NTI Matrix Switch. Additionally, the Matrix Switch allows for multiple ways for the user to complete the same operation – ensuring that the Remote will work as expected, regardless of who uses it.

Note: For models with audio support, these commands will switch the video and audio signals simultaneously. For independent video and audio switching using the IRT-UNV, see "Independent Video and Audio Control" on page 53.

Changing Ports

The first, and most important operational use of the IR Remote is changing ports of the switch. This requires the selection of both input and output ports. There are several methods of control.

Channel Surfing

The "IN +/-" and "SCAN" buttons can be used to surf through input port connections. However, since there are multiple outputs/users, the question becomes "which output connection is being changed?" As a result, it is required that an output be selected prior to using the "IN +/-" buttons.

The output port can be selected in two ways:

- by pressing the "OUT" button before selecting the output port number
- by pressing the "OUT" button after selecting the output port number

In both cases, the user must enter the output port number using the Numeric Keys (0-9). However, when the "OUT" button is pressed prior to selecting the port number, there will be a two (2) second delay after the last digit of the output port is entered that must expire before the output port is accepted. To avoid this delay, press the "ENTER" button to immediately accept the port number.

Once the output port has been accepted, there will be a five (5) second timeout, during which the user must press another button ("IN +," "IN -," or "SCAN"). Each subsequent press of "IN+" or "IN-" will renew the timeout, waiting for you to press it again (to advance or go back by one more Input channel). If no new command is sent to the switch before the timeout expires, the switch will forget the selected output, and pressing the "IN +/-" buttons will have no effect.

All output channels can surf inputs at once by pressing the "*" button prior to pressing the "IN +/-" buttons.

Examples:

Change connection of Output 1 from Input 1 to Input 3:

<OUT> + <1> + wait 2 seconds + <IN+> + <IN+>

<OUT> + <1> + <ENTER> + <IN+> + <IN+> (must press <IN+> within 5 seconds of pressing <ENTER>)

<1> + <OUT> + <IN+> + <IN+> (must press <IN+> within 5 seconds of pressing <OUT>)

Jump To Input

With the output port selected, a user knowing the desired input port number can enter it using the Numeric keys (0-9). Just as with using the “OUT” button, pressing the “IN” button after the number will force the command immediately. If the “IN” button is pressed prior to the port number, the “ENTER” button must be pressed to avoid a two (2) second delay before the input port is accepted.

Examples:

Quick method to change Output 1 from Input x (any) to Input 8:

<1> + <OUT> + <8> + <IN>

Quick method to change Output 12 from Input x (any) to Input 20:

<1> + <2> + <OUT> + <2> + <0> + <IN>

Jump To Output

Users can also change ports by specifying the input port number first. Similar to selecting the output port first, the “IN” button can be pressed either before or after entering the port number. Once the input port has been selected, the output port can be selected, following the same format as “Jump to Input...”

Expiration of a five (5) second timeout will force the switch to forget the entered input port number.

Example:

Quick method to change Input 1 from Output x (any) to Output 8:

<1> + <IN> + <8> + <OUT> (must enter the <x> + <OUT> command within 5 seconds of pressing <IN>)

Connect All

It may be desirable to broadcast the video (and audio) signals from one input to all of the outputs. In this situation, the user can quickly make all of these connections by using the “*” (asterisk) button which selects all outputs. With the input port selected, pressing the “*” button will immediately force the command to connect all output ports to the selected input.

Example :

Connect all users to Input 2:

<2> + <IN> + <*>

The “*” button can also be pressed prior to selecting the input port. In this case, the command will take effect once the input port has been selected.

<*> + <2> + <IN>

If no command is received before the five (5) second timeout expires, the switch will forget the “*” key-press.

Save and Recall

The SM-8X8-DVI-LCD video matrix switches provide the ability to save and recall up to 10 switch configurations (up to 100 in the 16X16 and 32X32 models). The switch configurations define the current port connections, volume control settings, and video blank status. The IRT-UNV IR Remote can be used to access these configurations by using the "SAVE" and "RECALL" buttons.

8x8 Model

To save a configuration, press the "SAVE" button followed by a Numeric key (0-9) corresponding to the memory slot the configuration is to be saved in. Pressing a single numeric key will immediately force the switch to save the current configuration to the selected memory slot.

Configurations can be recalled in much the same manner. To recall, press the "RECALL" button followed by the numeric key corresponding to the memory slot from which the configuration is to be recalled. Pressing a single numeric key will immediately force the switch to recall the selected configuration.

16x16 and 32x32 Models

To save a configuration, press the "SAVE" button followed by Numeric key(s) 0-99 corresponding to the memory slot the configuration is to be saved in. After the numeric key(s) press the "Enter" button. If the "Enter" button is not pressed, after two seconds the function will timeout and the number entered will be saved as that configuration.

Configurations can be recalled in much the same manner. To recall, press the "RECALL" button followed by the numeric key(s) corresponding to the memory slot from which the configuration is to be recalled. After the numeric key(s) press the "Enter" button. If the "Enter" button is not pressed, after two seconds the function will timeout and the number entered will be recalled to the current configuration.

Multiple Switch Control

All compatible NTI matrix switches will work with the same IRT-UNV IR Remote control. As a result, a user with multiple NTI matrix switches may find that, if the switches are installed too close together, both switches may respond to an IR command intended only for one switch. Or, the user may want to control multiple switches with a single remote, instead of having one remote per switch. To accommodate this situation, the IRT-UNV IR Remote provides the "SYS" button, which can be used to select the NTI switch to be controlled.



All switches will have the capability to allow the user to set the switch address (0-15). Each switch to be separately controlled must be set to a different address prior to using the Remote Control. With the addresses set, press the "SYS" button on the IRT-UNV, followed by a two digit number corresponding to the address of the matrix switch to be controlled.

Upon accepting the "SYS" command, the switch with the corresponding address will illuminate the "IR" LED and respond to all IR Remote commands and will blink the "IR" LED on the front of the switch for visual indication. All other switches will ignore any further commands, until the "SYS" button is pressed again. To select a new NTI switch to control, press the "SYS" button again and repeat the process.

Canceling a Command

Considering the number of key presses required for some of the commands, it's possible that the user may inadvertently press an incorrect button. Should this happen, the user can press the "ESC" button to cancel a command. Provided the command has not been accepted by the system, pressing the "ESC" button will cause the switch to "forget" or "erase" all button commands from the current command sequence. Once the command sequence has been cancelled, the user can begin entering the command again.

Independent Video and Audio Control

For models that support video and audio, the video and audio ports can be independently switched by including in the commands the Video () or Audio () buttons just prior to the rest of the command. For example:

Connect all speakers to audio input 2

<  > + <2> + <IN> + <*>

Connect Video Source Input 1 from Video Output x (any) to Video Output 8:

<  > + <1> + <IN> + <8> + <OUT> (must enter the <x> + <OUT> command within 5 seconds of pressing <IN>)

Technical Specifications For IRT-UNV

Number of Controllable Systems	Max: 15
Pushbutton Control	29 keys
Power supply	2x AAA Battery
Chassis material	Plastic
Approvals	RoHS

Troubleshooting the IRT-UNV

PROBLEM	SOLUTION
IRT-UNV is not selecting outputs or inputs	<ul style="list-style-type: none"> • Check battery • The IRT-UNV may be configured to control the wrong switch- see "Multiple Switch Control" above.

Troubleshooting the VEEMUX

PROBLEM	SOLUTION
VEEMUX will not boot up	<ol style="list-style-type: none"> 1. Make an RS232 connection to the VEEMUX as described on page 6. 2. Set the terminal program to communicate at 115200bps. 3. Power ON the VEEMUX and, as it is powering up, press and hold the <Tab> key until a boot prompt appears (VEEMUX>) in the terminal program. 4. At the boot prompt type the following: <div style="text-align: center;"> <code>VEEMUX>nand erase config</code> and press the <Enter> key. </div> 5. Power-cycle the VEEMUX. It should bootup and resume normal operation with all factory default settings restored. Any customized settings previously entered will be erased and will need to be re-entered.

GENERAL TECHNICAL SPECIFICATIONS

Video	
Video Amplifier Bandwidth	165MHz
Input Video Signal	1.2 volts p-p
Input DDC Signal	5 volts p-p (TTL)
Single Link Range	1080p/1920 x 1200
DVI Connector	DVI-I 29 pin female
Audio (Audio Switches Only)	
Audio Connector	3.5mm jack
Audio Signal Type	Stereo unbalanced
Audio: Frequency response	20Hz to 20kHz, +/- 0.5dB
THD + N	0.01% @ 1kHz
S/N	>90 dB
Crosstalk	> 85 dB @ 1kHz
Audio Input: Impedance	10kOhm
Max. input level	1Vrms or 2.5Vp-p
Audio output: Gain adjustment	-20dB to +10dB (-20dB to 0dB for 32x32)
Impedance	< 0.1 Ohm
Control	
Serial	RS232, RJ45 female connector
USB Console	Virtual Serial Port- USB Type B female connector
Ethernet	RJ45 female connector
Infrared	IR Receiver (works with remote control transmitter)
Power	IEC connector for 100-240VAC power connection

Dimensions:

Without Audio	Rack Unit	WxDxH (In.)	With Audio	Rack Unit	WxDxH (In.)
SM-4X4-DVI-LCD without Rackmount kit	n/a	16.2x10x1.75	SM-4X4-DVIA-LCD without Rackmount kit	1RU	17.5x10x1.75
SM-4X4-DVI-LCD with Rackmount kit	1RU	19x10.1x1.75	SM-4X4-DVIA-LCD with Rackmount kit	1RU	19x10x1.75
SM-8X8-DVI-LCD without Rackmount kit	n/a	17.4x10.1x1.75	SM-8X8-DVIA-LCD	2RU	19x12x3.5
SM-8X8-DVI-LCD with Rackmount kit	1RU	19x10.1x1.75	SM-16X16-DVIA-LCD	2RU	19x12x3.5
SM-16X16-DVI-LCD	2RU	19x12x3.5	SM-32X32-DVIA-LCD	3RU	19x17x7
SM-32X32-DVI-LCD	3RU	19x16x7			

INDEX

audio connections.....	8	optimize video.....	42
audio control-infrared.....	52	password.....	31
audio control-web interface.....	46	rack mounting.....	4
Backup.....	34	reboot.....	45
baud rate.....	18	Restore.....	34
control options.....	9	RS232 pinout.....	18
DDC.....	41, 42	Scanning Sequences	38
Device Discovery Tool.....	47	SerTest.....	22
drivers-USB	13	standby mode.....	44
firmware.....	43	Telnet Interface.....	24
front panel LCD.....	9	Telnet-Port 2005.....	26
IP address.....	31, 35	USB COM port.....	13
IRT-UNV.....	48	USB connection.....	6
Java.....	47	user management.....	40
LAN.....	31	username and password.....	31
materials supplied.....	2	Video Switch.....	33
Matrix Switcher's Control Program	21	web browsers.....	1
Matrix-Y-1 cable.....	18		

WARRANTY INFORMATION

The warranty period on this product (parts and labor) is two (2) years from the date of purchase. Please contact Network Technologies Inc at **(800) 742-8324** (800-RGB-TECH) or **(330) 562-7070** or visit our website at <http://www.networktechinc.com> for information regarding repairs and/or returns. A return authorization number is required for all repairs/returns.

MAN124 Rev. 10/8/13