

SERVICE INFORMATION

AUDIO TELEX DCM250 POWER AMPLIFIER

CONTENTS:

OPERATION MANUAL

CIRCUIT DESCRIPTION

SET-UP / TEST PROCEDURE

SCHEMATIC DIAGRAMS

PCB OVERLAYS

COMPONENT LISTS

Australian Monitor
1 Clyde Street, Silverwater NSW 2128 Australia
+61 2 9647 1411

www.australianmonitor.com.au

Operating Instructions

DCM250
250 Watt Power Amplifier



Audio Telex Communications Pty Ltd

ACN 001345482 Incorporated in NSW

NSW & ACT	QLD & NT	VIC
149 Beaconsfield St Private Bag 149 Silverwater NSW 2128 Australia Ph 02 96471411 Fax 02 96483698	42 Commercial Rd PO Box 871 Fortitude Valley Qld 4006 Ph 07 38521312 Fax 07 32521237	4/26-30 Howleys Rd Notting Hill Vic 3168 PO Box 468 Mt Waverley Vic 3149 Ph 03 95628566 Fax 03 95628781
WA	SA	TAS
7/64-66 Kent St PO Box 489 Cannington WA 6107 Ph 09 3562761 Fax 09 3562762	Electronic Concepts Pty Ltd 76 George St Thebarton SA 5031 PO Box 7034, Hutt St Adelaide SA 5000 Ph 08 2349444 Fax 08 2349441	K W McCulloch Pty Ltd 54A Albert Rd Moonah 7009 Ph 002 286373 Fax 002 781063
New Zealand		
Unit B, 11 Piermark Drive PO Box 512 Albany 1331 Ph 09 4159426 Fax 09 4159864		

DCM250, 250 Watt Power Amplifier

Product Description

The DCM250 is a 250 watt power amplifier in a two rack unit (2RU) chassis suitable for table or direct 19" rack mounting. The DCM250 has outputs for 100 volts & 4 ohms. It has a balanced input of 10K ohms. The DCM250 will operate from 240 VAC @ 50 Hz or 110 VAC @ 60 Hz (not user selectable, internal, factory adjustment only, specify at the time of ordering) or 24 VDC and will meet it's full performance specification on either voltage supply. The DCM250 also features a DC battery trickle charge facility, auto-sensing fan cooling, plus overload, short circuit and over temperature protection. The maximum recommended load for the DCM250 is 40 ohms.

Initial Set Up

There is an unlabelled, screwdriver adjustable output level control located centrally on the front panel of the DCM250. Turning this control in the clockwise direction will increase the power output, turning this control in a counter-clockwise direction will reduce the power output. The factory default setting for this control is such that a 1 volt input will give a 100 volt output.

Front Panel Controls

Output Level: The output level control is unlabelled, recessed (screwdriver adjustable) and is located in the centre of the front panel, just to the right of the DCM Series logo. Turning the control clockwise will increase the output of the DCM250 towards it's maximum output level while turning the control counter-clockwise will decrease the output level. Adjust this control for the desired output level depending on the level of the input signal (from a mixer or other signal source). The factory default setting for this control is such that a 1 volt input will give a 100 volt output.

Power Switch: The rocker switch located in the front centre of the panel turns AC power on to the DCM250. Rocking the power switch to the right turns the AC power 'on'. When the AC power is 'on', a green LED will glow in the amplifier status display window. Please note that this switch does not switch DC voltage. If a DC voltage supply is connected to the DCM250, the amplifier will operate as soon as the connection is made, regardless of the position of the AC power switch. If both an AC and DC voltage supply are connected and you rock the AC power switch to the 'off' position, the DCM250 will automatically continue to operate normally from the DC supply (and the 'mains failure' LED in the amplifier status display window will also glow under these conditions; see the amplifier status display window section under Front Panel Controls later in this manual).

Cooling Fans (Air Intake): The cooling fans (two installed in the case of the DCM250) are temperature sensitive and only switch on when the temperature of the DCM250 had reached a pre-determined range. The fans will stay on and only switch off again once the temperature of the DCM250 has fallen below a pre-determined level. So, the fact that the fans are not operating at any time (and most noticeably to the operator at turn-on) does not mean that the amplifier is faulty in any way, just that it is operating within a temperature range that does not need fan cooling for adequate heat dissipation. If the DCM250 is operating continually at conservative levels and proper load conditions, it is possible that the cooling fans will not switch on at any time during normal operation. When operating, the fans cause air flow from the front to the rear of the DCM250.

Continued next page ➡

Amplifier Status Display Window: The status display window highlights the operating conditions of the DCM250. Please refer to Figure #1 on the back page of this instruction sheet with numerical reference as follows:

- 1 **High Temperature:** This red LED glows if the fan has failed and the amplifier has been shut down by its' temperature control circuitry. If this LED is glowing and the fans have not failed, it means that the amplifier is operating in an ambient environment that it naturally too hot for fan cooling to make any difference to the temperature of the amplifier.
- 2 **Power:** This LED glows green if AC power is switched on to the DCM250. Note that this LED does not indicate the presence of a DC supply voltage
- 3 **Mains Failure:** The LED glows red if there is a failure in the AC mains power supply. However, this LED will only glow if there is a DC supply voltage present. If no DC supply voltage is present then this LED will not glow.
- 4 **Output Level VU Meter:** A 10 segment LED VU meter is provided to give an indication of the output signal level of the DCM250 from -25 to +3 dB. For normal operation the LED's should oscillate in and out of the red zone. If the LED's in the red zone are lit continually, then the output level control (or the level of the input signal to the DCM250) should be adjusted to reduce the output level. Too much output level can cause distortion and possible damage to the connected speaker system.

Rear Panel Connections

Please refer to Figure #2 on the back page of these instructions with numerical references as follows:

- 1 **3 pin IEC, AC mains power inlet.** The operating voltage is 240 VAC @ 50 Hz or 110 VAC @ 60 Hz. The AC power voltage level is **not** externally user selectable but is factory pre-set (via transformer selection). The inlet is equipped with an inbuilt AC fuse holder fitted with a 6 Amp slow blow fuse plus one spare fuse. Power consumption is 400 VA. **Please ensure that the mains power cord is disconnected before attempting to check or replace this fuse.**
- 2 **Output terminal strip .** Reading from left to right these connections are as follows:

Common for low impedance
4 Ohms
Common for constant voltage systems
100 volts
- 3 **24 VDC power connection.** The left side red post is the + (positive) terminal while the right side black post is the - (negative) terminal. The DC current drain is 15 Amps, maximum at full power. This socket also provides trickle charge to a DC battery supply (if connected) when the DCM250 is operated from AC mains power. The level of trickle charge is 300 mA, maximum.
- 4 **Twin DC low voltage, fuse receptacles.** Access the DC fuses is by turning the cap half a turn counter-clockwise with a screwdriver. The value of the fuses is 10 Amps slow blow. **Please ensure that the AC power switch is in the 'off' position and that the mains power cord is disconnected before attempting to check or replace this fuse**
- 5 **Input (& parallel output) XLR signal connection.** The input to the DCM250 is transformer balanced @ 10K ohms. The pin configuration of both sockets is as follows: pin #1-earth; pin #2-active (high, +); pin #3-active (low, -). The output socket is to allow the original input signal to be fed on to another amplifier. As these two sockets are wired in passive parallel, the failure of any one amplifier will not affect the signal flowing through that amplifier to another amplifier.

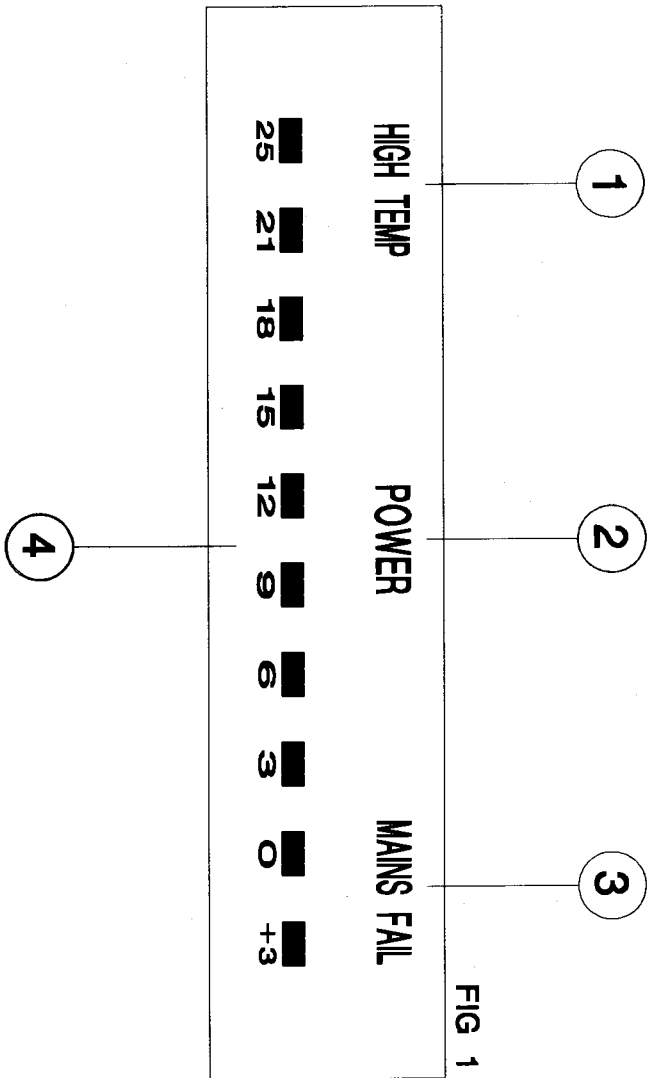

FIG 1

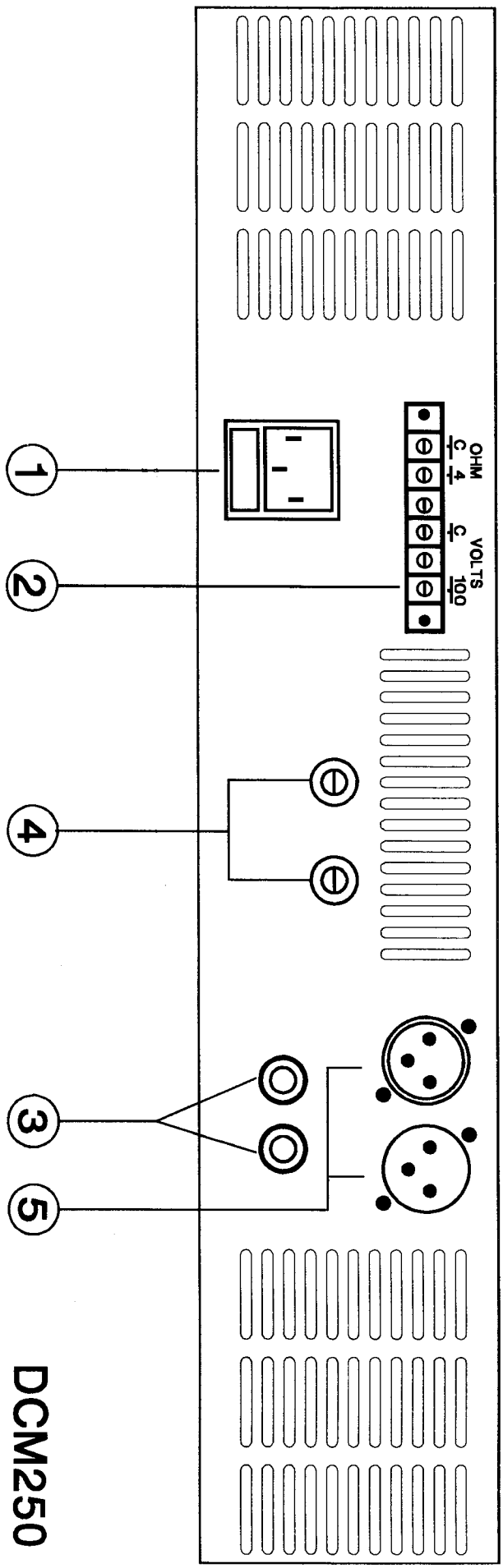

FIG 2

DCM250

DCM Series

Circuit Description

The DCM series are power amplifiers designed for commercial installations. They can be used for either low impedance (4 ohm/8 ohm) or constant voltage line speakers (100v/70v). These amplifiers can be mounted in a standard 19" equipment rack or they can be used on a shelf or table. The DCM series feature line level input (with parallel output) and are normally used with mixers, mixer amplifiers or other power amplifiers. The DCM series will operate from mains voltage or 24VDC. The DCM series also feature a DC battery trickle charge facility, auto-sensing fan cooling, plus overload, short circuit and over temperature protection.

Power Switch

This switch controls the switching of AC power to the amplifier. A blue 'On' LED will indicate whether the amplifier is switched on or off. This switch will not switch DC power on or off in DC operation. In DC operation mode, the amplifier is always on and the blue power LED will always be illuminated. If both AC and DC voltage supply are connected and the AC power switch is in the off position, the amplifier will continue to operate normally from the DC supply and the mains fail LED will indicate.

Level Control

The output level control is located in the centre of the front panel. It is a fully recessed screwdriver adjustable pot. Turning this pot cw will increase the gain of the amplifier. At maximum setting the input sensitivity is 300mV. The amplifier ships from the factory with the sensitivity set to 1V.

Amplifier Status Display

This VU meter indicates the output level of the amplifier. The sensing for the circuit is taken on the amplifier side of the output transformer. The 0dB level is referenced to 100V. This is an RMS meter, not a peak meter.

Protect

The protect LED will illuminate when the amplifier cuts out because of either over current or high temperature. The amplifier will switch back on after approx 4 sec for an over current trip. The amplifier will switch back on after the amplifier has cooled to 60degC for a thermal trip.

Limiter

The limiter is a hard limiter with an attack time of about 1msec. It is defeatable by removing the jumper on the solder side of the front pcb. This however is not recommended as voltage overload and speaker transformer current saturation may cause the amplifier to cut out under normal program material.

Current Limit and Setup

Current limit is controlled by a microprocessor (PIC12C509A). The detection is done by sensing voltage across the emitter resistors. Trimpot P1 on the front pcb is accessible through the hole in the top right of the chassis return (only visible with the lid off). Turning the trimpot ccw will decrease the point at which the amp cuts out ie the amp will cut out earlier. (P1 resistance is increased.)

To set the current limit:

1. Reset the trimpot P1 turning fully clockwise.
2. Connect the amplifier to half it's minimum load (10ohm for DCM500, 20ohm for DCM250, 40ohm for DCM120).
3. Run an rms 1kHz sine wave into the amplifier and set the input level so that you read 425mVDC (DCM250/500) or 825mVDC (DCM120) across the emitter resistor, measuring the side which has the higher current (measured as a voltage across the emitter resistors).
4. Turn the trimpot P1 ccw till the amplifier cuts out. The amplifier is set to the factory default.

Thermal and Fan control and Setup

The thermal cutout and fan is controlled by a microprocessor (PIC12C509A). The temperature is sensed using a 10k@25degC NTC. The fan is normally off and turns on to full speed at 60degC. This temperature is fixed and not adjustable. The thermal cutout temperature is set using the trimpot accessible through the hole in the top left side of the chassis return (only visible with the lid off). Turning the trimpot cw will decrease the point at which the amp cuts out ie the amp will cut out earlier.

Power Amp

The power amplifier is a push pull single supply amplifier driven by a class A transformer coupled front end. The drive is provided by HEXFETs (RF9520/9530) into NPN BJTs (TIP35C). When replacing the FETs it is recommended that you replace both FETs. The matching of these FETs determines the balancing of the emitter currents in the output devices. For optimum performance the emitter currents in each side should match to within 30% of each other.

Bias Setup

The amplifier is set with a bias setting of 1mV measured across the emitter resistors.

Bias is set using the trimpots located on the power pcbs on each side of the amplifier.

Turning the trimpots cw increases the bias.

If the HEXFETs have been replaced the resistor in series with the pot may need to be changed. Use a lower value resistor if the bias cannot be turned off or a higher value if the bias cannot be turn on.

AC Power Inlet

The operating voltage is 230/240 VAC @ 50 Hz. The 3 pin IEC power inlet is located on the bottom left of the rear panel and accepts a standard mains power lead fitted with an IEC connector. Before plugging in a power lead, please check the rear panel of the amplifier to ensure that the voltage switch is set correctly for your part of the world.

The inlet is equipped with an in-built AC fuse containing the rated fuse and a spare.

24 Volt DC Power Inlet

The DCM series feature optional 24VDC power to run off a battery back-up if required. This is connected via the rear binding posts. The front panel Power Switch will not switch DC power 'on' or 'off' in DC operation. In this mode the amplifier is always 'on'.

The trickle charge resistor across the diode is a 47ohm/5watt wire wound resistor. The maximum trickle current is 300mA supplied from internal 35V rails.

230V/240V Slide Switch

The operating voltage of the amplifier is user selectable between 230V and 240V via a slide switch located on the center of the rear panel. This switch should be set to match the AC voltage of your country. The mains transformer is wound with a 230V winding plus a 10V winding internally connected.

Speaker Output Terminal Strip

The screw terminals located on the top left of the rear panel allow access to the direct speaker outputs of the amplifier. Reading from left to right the terminals are:

COM	Common or “-” for low impedance speaker loads (4 or 8 ohms)
4	Positive “+” for 4 ohm speaker loads (use with common)
8	Positive “+” for 8 ohm speaker loads (use with common) DCM120 only
COM	Common or “-” for 70v or 100v speaker loads
70	Positive “+” for 70v line speaker loads (use with common) DCM120/500 only
100	Positive “+” for 100v line speaker loads (use with common)

Please ensure that the correct “Common” is used. Low impedance and 70/100v loads can be used simultaneously but please pay careful attention to the overall speaker load.

Note: The minimum impedance (or maximum load) at 100 volt line should be no less than

DCM120 – 80 ohms
DCM250 – 40 ohms
DCM500 – 20 ohms

XLR Audio Input and Parallel Output

The DCM series includes both male and female 3 pin XLR connectors per channel. While the female is normally used as the input to the amplifier, both XLR's are connected in parallel so either will work.

The XLR's inputs are transformer balanced and wired as:

Pin 1: Shield.

Pin 2: Hot, +, Positive

Pin 3: Cold, -, Negative

Fuse Sizes

(DCM120)

Mains: 230 VAC 4 Amperes Slow Blow HRC 20x5mm

DC: 10 Amperes Slow Blow HRC 20x5mm

(DCM250)

Mains: 230 VAC 6.3 Amperes Slow Blow 20x5mm

DC: 2 x 10 Amperes Slow Blow HRC 3AG

(DCM500)

Mains: 230 VAC 10 Amperes Slow Blow HRC 20x5mm

DC: 2 x 35 Amperes Slow Blow 3AG

TESTING PROCEDURE OF DCM 120/DCM 250/DCM 500

I. PRE-TESTING (of complete sets).

- **Check**

- 1.1 All screw for tightness (Bridge rectifier and transistor bolts)
- 1.2 Earth Connection for good contact (solder and crimpling)
- 1.3 This setup has signal input to the Amplifier through male (XLR)
- 1.4 Check with Multimeter that there is a DC resistance of about $250\ \Omega$ between Pin2 & Pin3 of each of XLR's. Also between (Pin 1 & Pin 3) and (Pin1 & Pin2). There should be very high resistance. (IE: no reading).

2. Electrical Check

2.1 Fuse Check:

	DCM 120	DCM 250	DCM 500
Mains fuse:	4AT	6.3 AT	10 AT
DC fuse:	10AT (x1)	10AT (x2)	35AT (x2)

2.2 Connect the Amplifier to the setup (Variac voltage = 0V) set all presets on front board (only) fully clockwise, voltage selector switch to 230V

2.3 Slowly increase the input voltage to 230V, keep watching the input current should not exceed 0.1A for DCM-120, 0.1A for DCM-250, 0.1A for DCM 500.

2.4 Check and reset if necessary all emitter resistor voltages with the help of preset. (Each emitter resistor voltage should be between 0.5 mV to 0.8 mV)

2.5 Check DC voltage Main rail = 33V

7815 input = 30V

7815 output = 15.5V

2.6 Give input signal of 500 mV to get outputs as follows (@ $4\ \Omega$ output load)/ 22V for DCM 120, 32VAC for DCM250, 44.7VAC for DCM 500. Check 100V O/p at 100vV line, Remove the input signal

II. FINAL TESTING

(This setup should have signal input to Amplifier through female (XLR)
(The limiter link should be out of circuit initially.)

1. Connect the Amplifier to the setup, set voltage selector switch to 240V
2. Switch ON the set to 240VAC.
3. Slowly increase the input signal (of 1kHz) keep watching the 24dB LED, it should glow at approx 9V output. Increase the input signal to get 70VAC output.
4. Check Dc voltage of all emitter resistors, Minimum value should be within 30% of the maximum value.
5. Slowly increase the input signal, keep watching the 0db LED, it should glow at 100V \pm 5V output voltage.
6. Set 100V 1kHz as 0db reference. Change frequency to 10kHz check dB level drop. It should be 2.5dB \pm 0.5dB.
7. Change the frequency to 1kHz, reduce signal level to get 10VAC output. Half the output load.
8. **Overload setting:** - Check the DC voltage at the emitter resistors having the maximum voltage value. Increase input signal to get 820mV for DCM 120, 425mV (for DCM250 & DCM 500). Turn preset (P2) anticlockwise such that it just mutes the output signal and signal returns back slowly after 2 seconds.
9. Reduce the signal & re check whether the signal mutes at the corresponding above stated voltages.
10. Again make the output load to original full value. Turn volume preset fully anticlockwise, set input signal strength to 1V, set volume preset clockwise to get 100V output.
11. Set input signal strength to get output 110V VAC. Insert limiter link, the signal should reduce to 100V \pm 5V.
12. Remove the input signal and check noise. It should measure less than 25mV.

III. THERMAL & SOAK TEST

1. Connect the Amplifier to the setup : Output load = 4 Ω Output Voltage: (DCM 120): 14V. (DCM 250):20V. (DCM 500): 40V
2. Set the Amplifier thermal cut off temperature at around 105°C with the help of preset P4.
3. Leave the unit "ON" (with lid fixed, if possible) for 24 hours.

IV. Sound Test/Listening test.

1. Switch On the set. Check for any switch on thump.
2. Connect CD player to the input, listen for irregularities if any.
3. Switch off the set check for switch off noises.

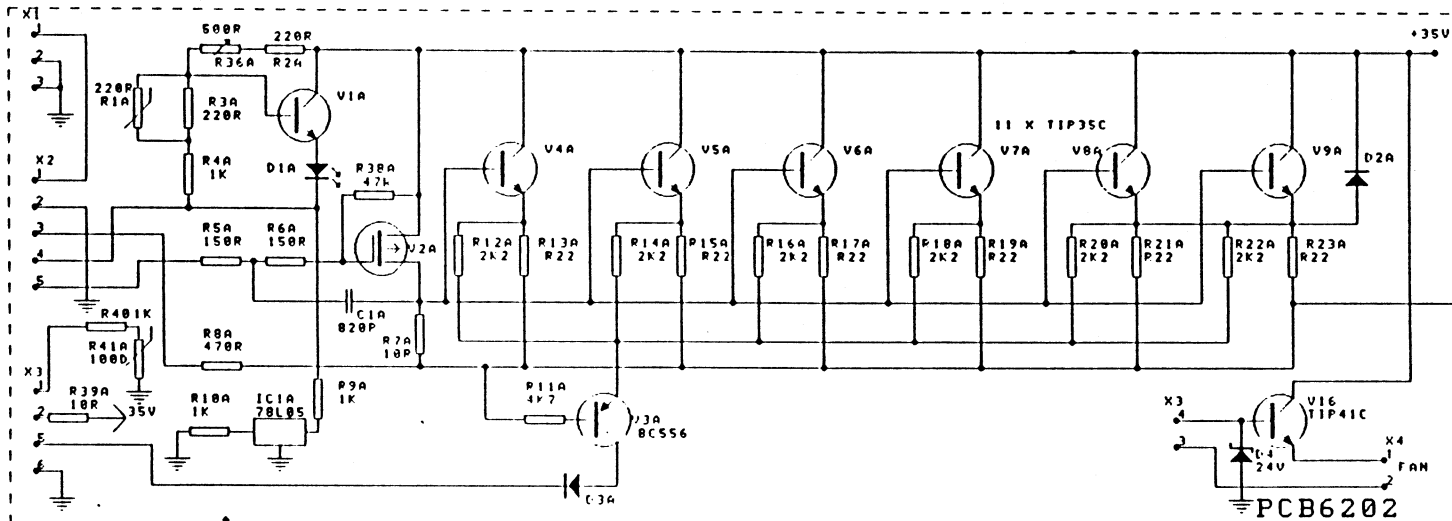

- PCB6201
 X1 TO PCB6136
 X2 TO PCB6200 X3
 X3 TO PCB6200 X4
 X4 TO FAN
- PCB6202
 X1 TP PCB6203
 X2 TO PCB6200 X1
 X3 TO PCB6200 X2
 X4 TO FAN

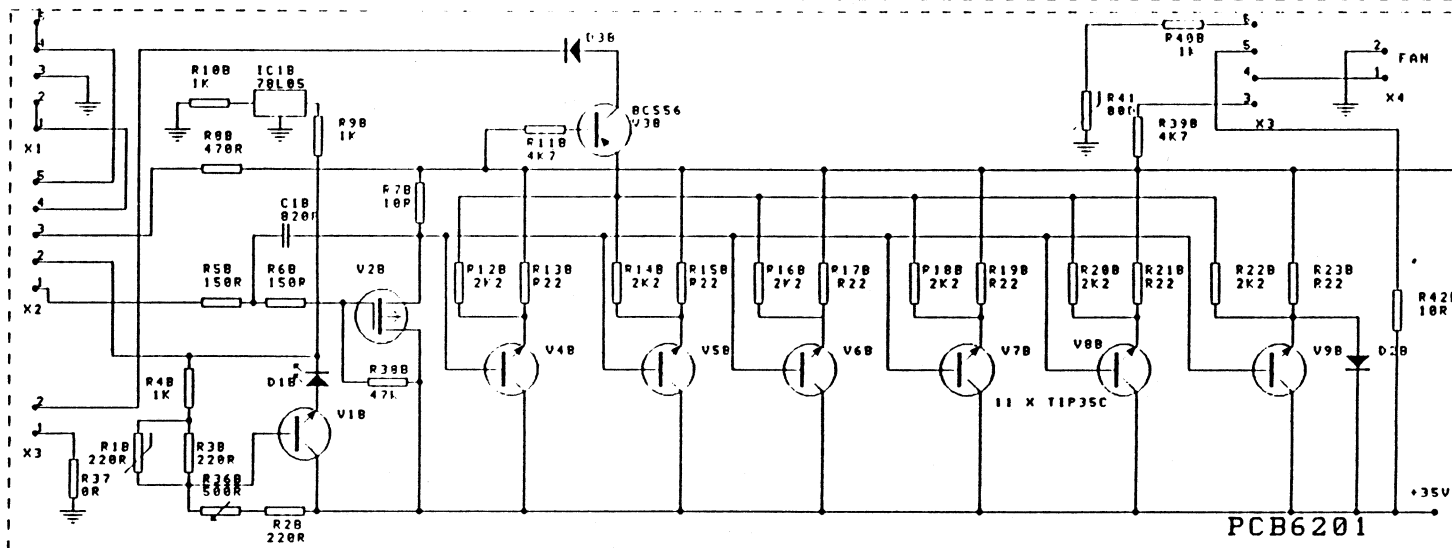

Title			DCM250 POWER PCB		
Size	Number	Revision			
A3	CD6201-2	A			
Date: 29-JUL-1996	Sheet: 2 of 2	Drawn By: RS			
File: P:\PCB\PARTS\CD6201-2					

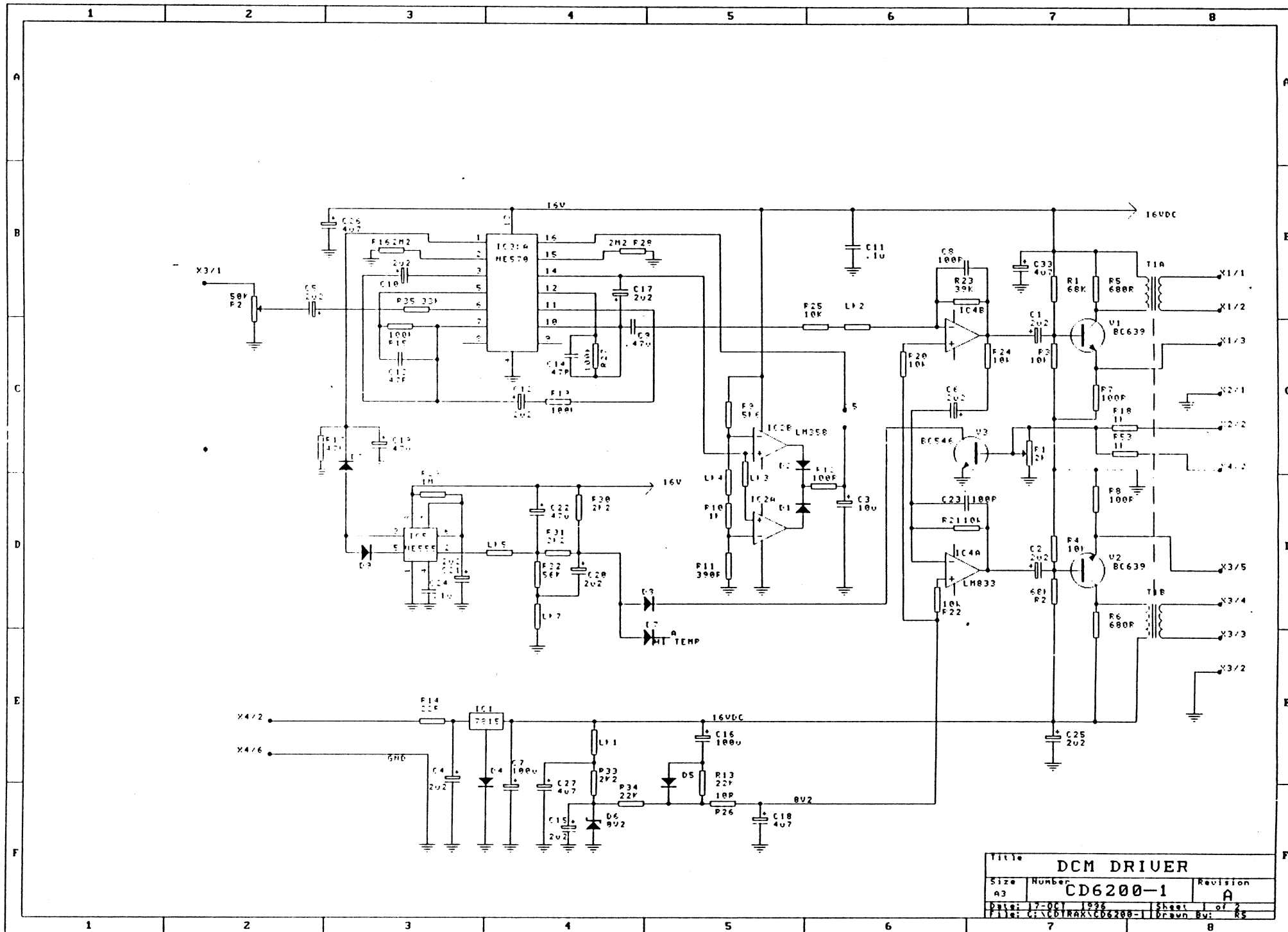

Title		DCM DRIVER	
Size	Number	Revision	
A3	CD6200-1	A	
Date: 17-OCT-1996	Sheet 1 of 2		
File: C:\CDTRAK\CD6200-1		Drawn By:	RS

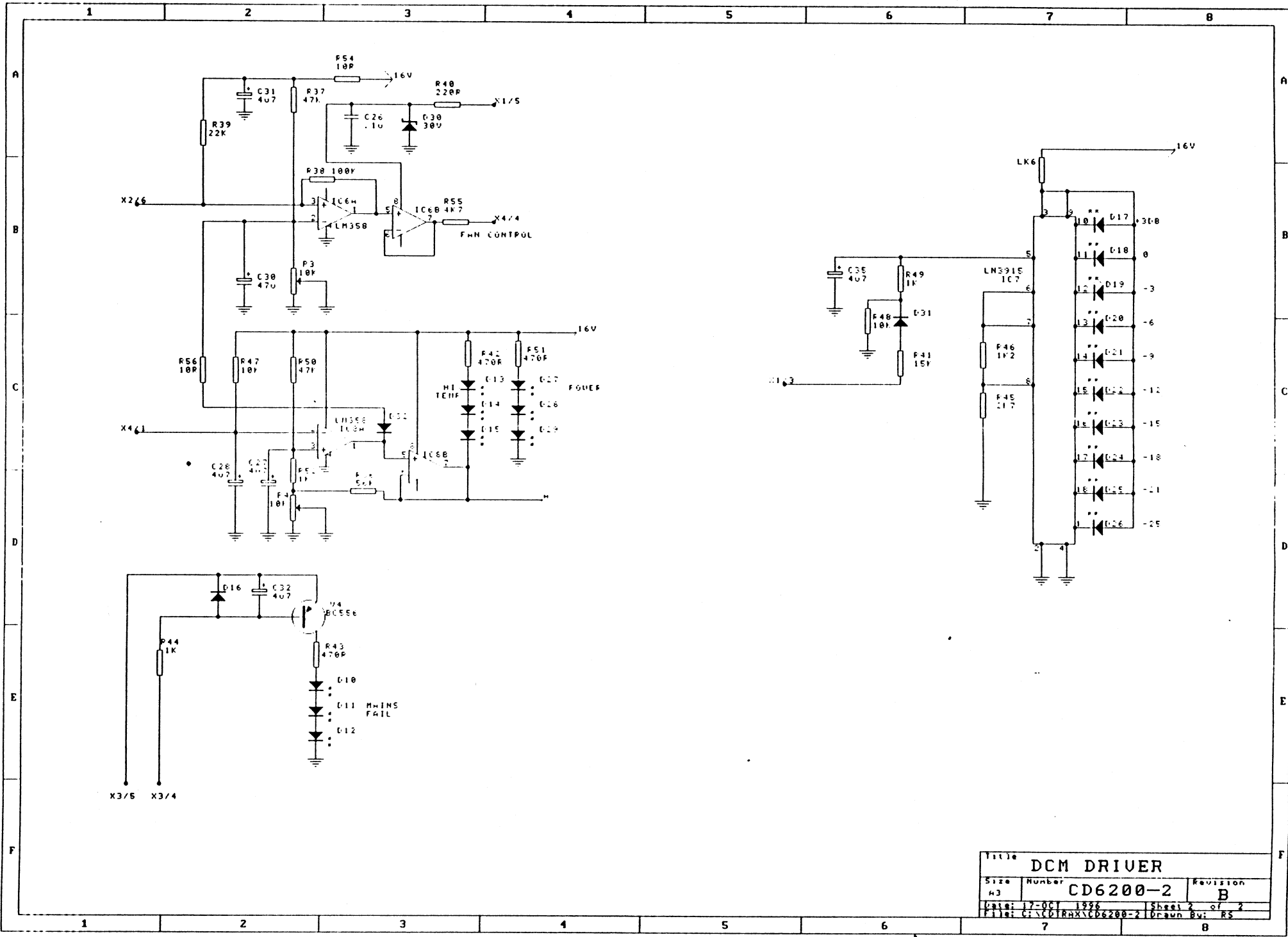

Title		
DCM DRIVER		
Size A3	Number CD6200-2	Revision B
Date: 17-01-1996	Sheet 2 of 2	
File: C:\CDTRHX\CD6200-2	Drawn By: RS	

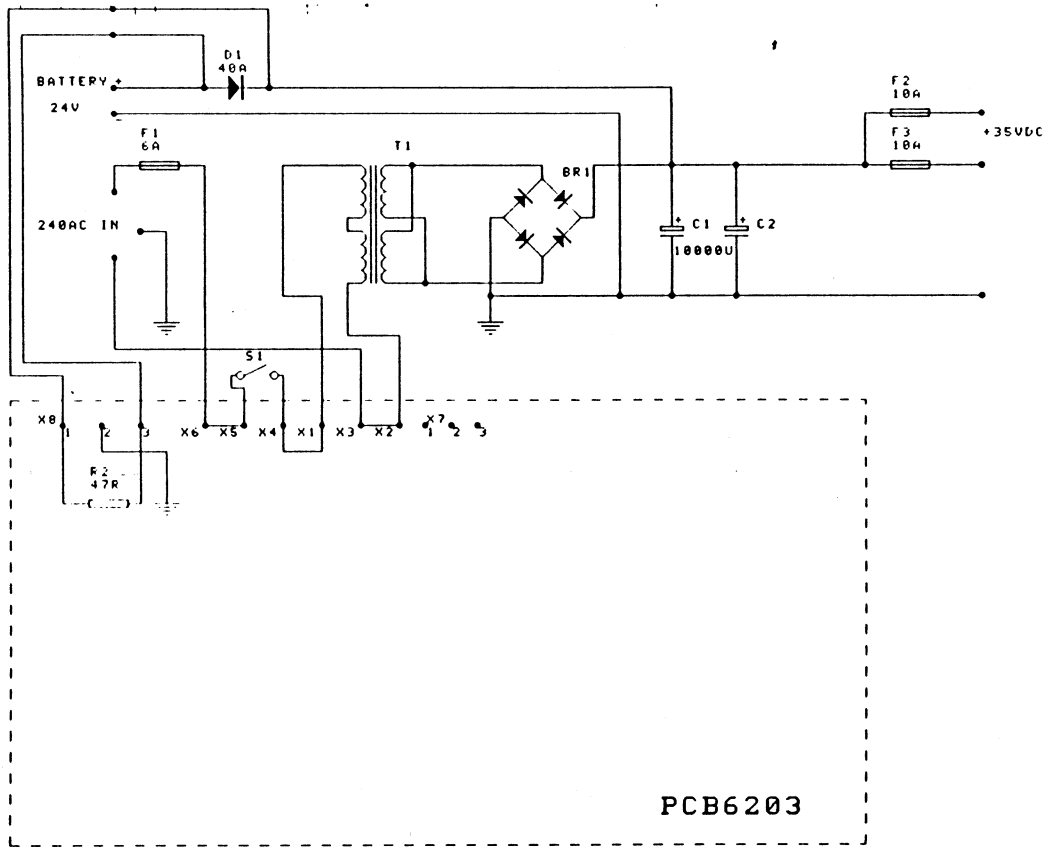

PCB6203

Title			DCM250 POWER SUPPLY		
Size	Number	Revision			
A3	CD6203-2				
Date: 24-JUN 1996			Sheet 2 of 2		
File: C:\CDTRAX\CD6203-2			Drawn By: KS		

1 2 3 4 5 6 7 8

A
B
C
D
E
F

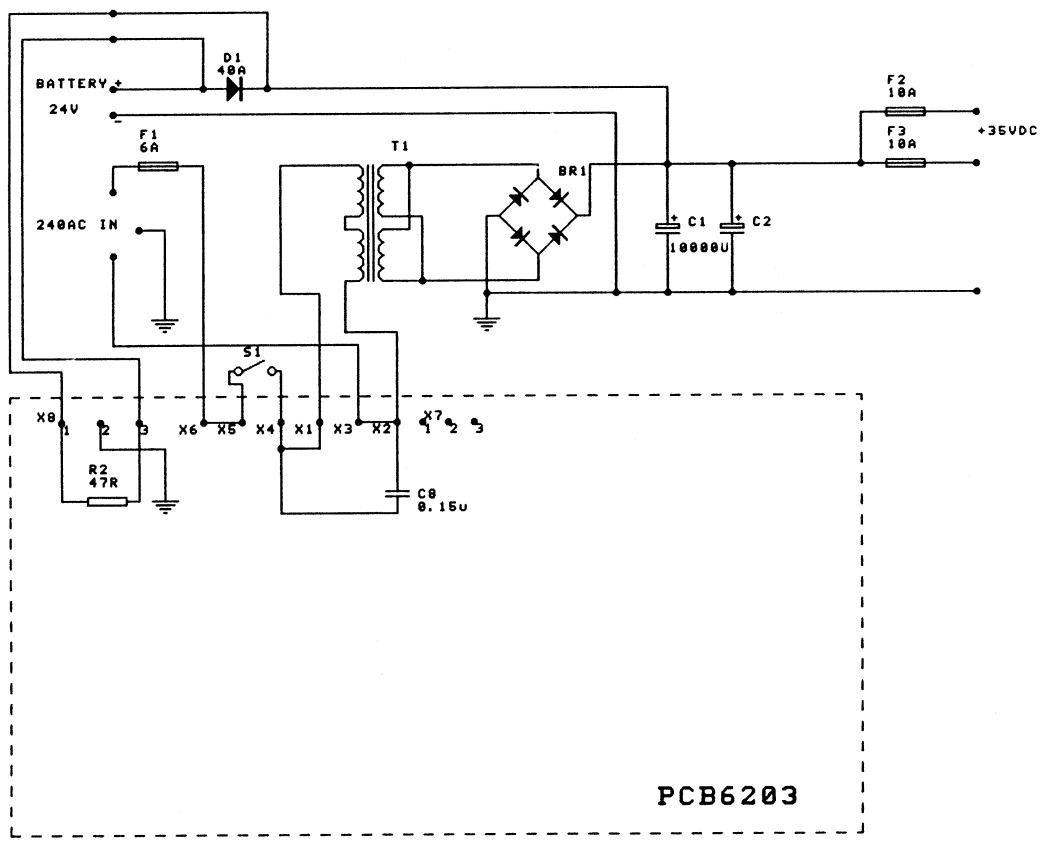

PCB6203

Title			DCM250 POWER SUPPLY		
Size	Number	Revision			
A3	CD6203-2	A			
Date: 22-JUL 1998			Sheet 2 of 2		
File: C:\CDTRAK\CD6203-2			Drawn By: RS		

1 2 3 4 5 6 7 8

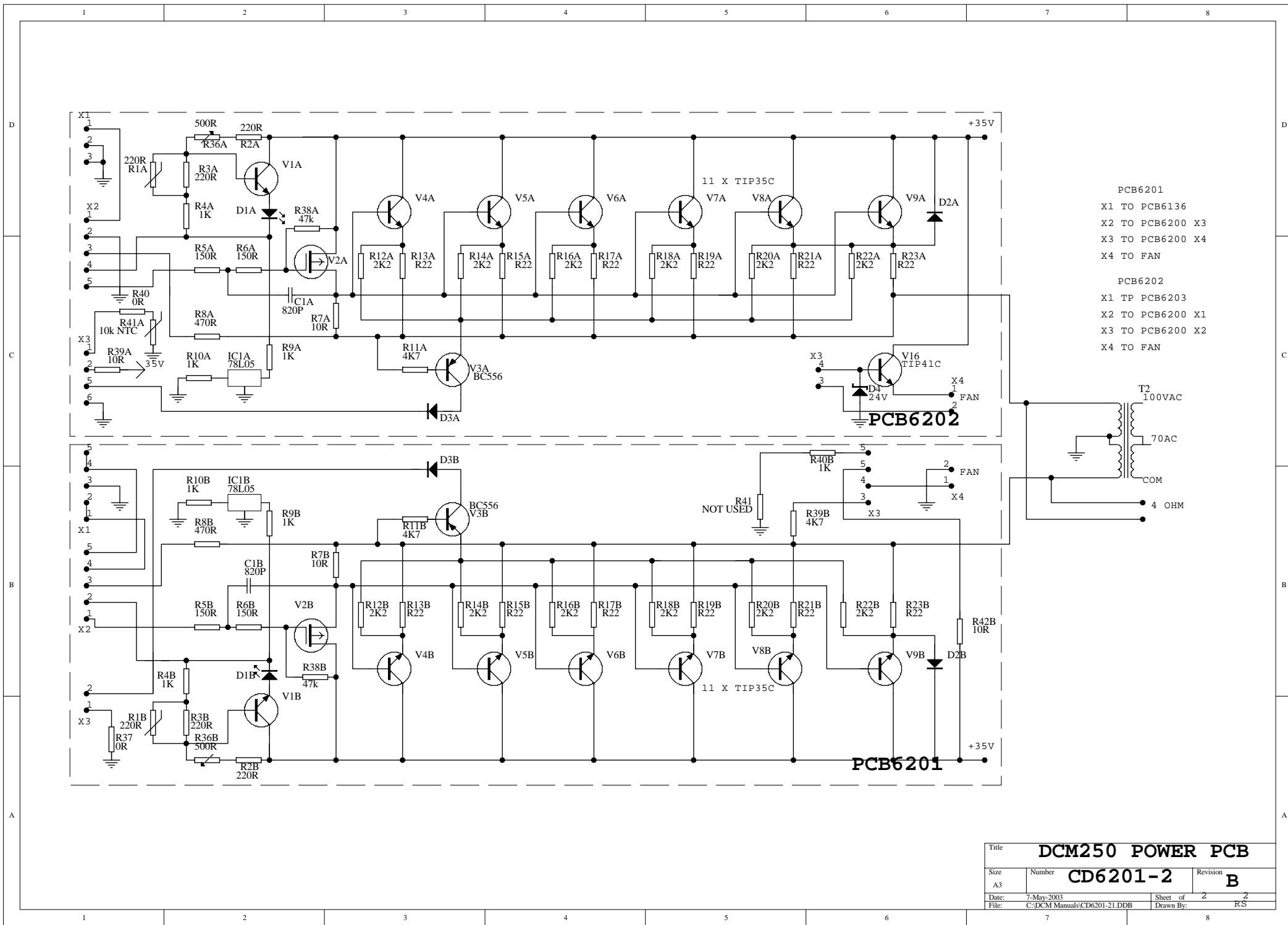

Title DCM250 POWER PCB		
Size A3	Number CD6201-2	Revision B
Date: 7-May-2003	Sheet of 2	2
File: C:\DCM Manuals\CD6201-21.DDB	Drawn By:	RS

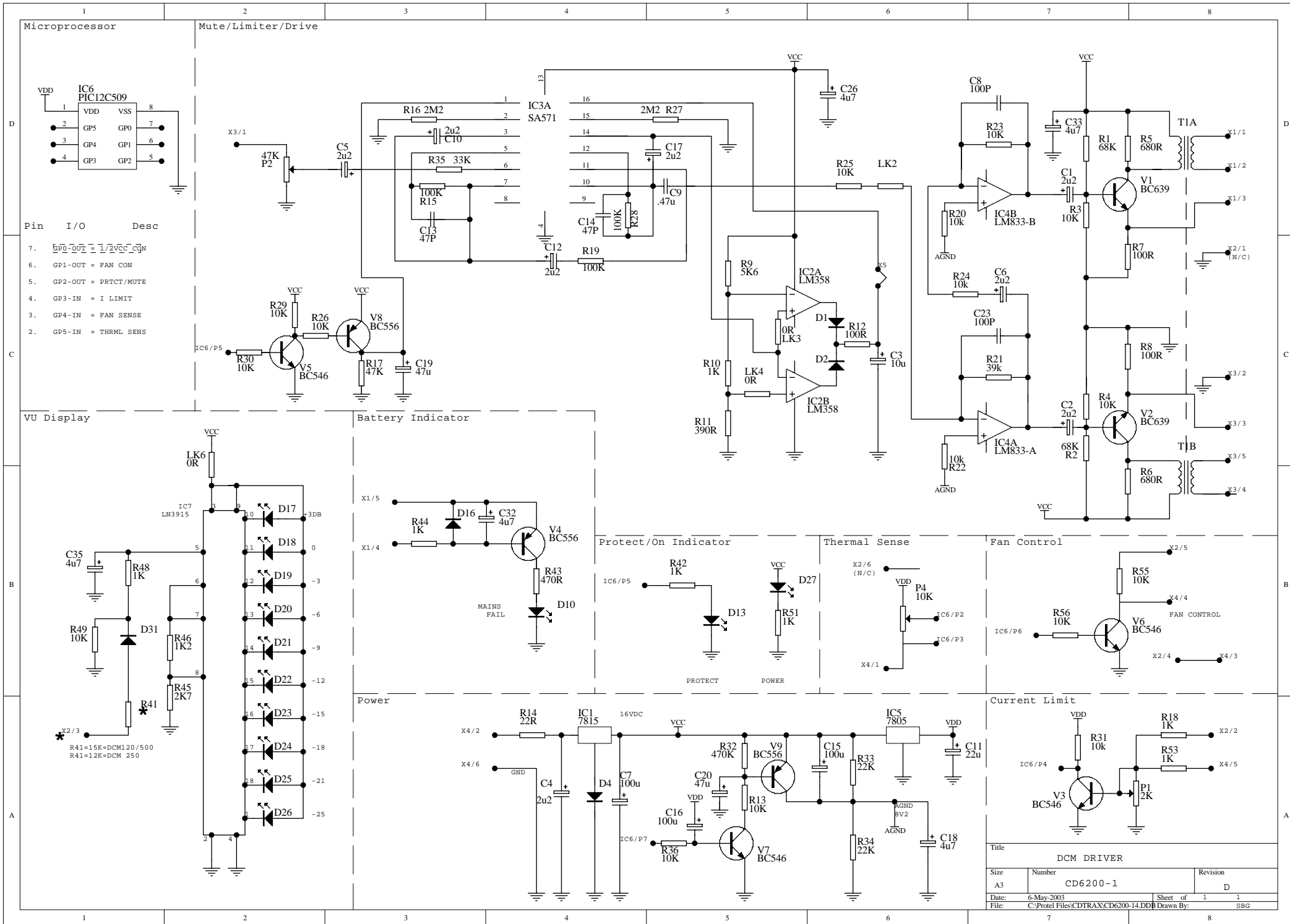

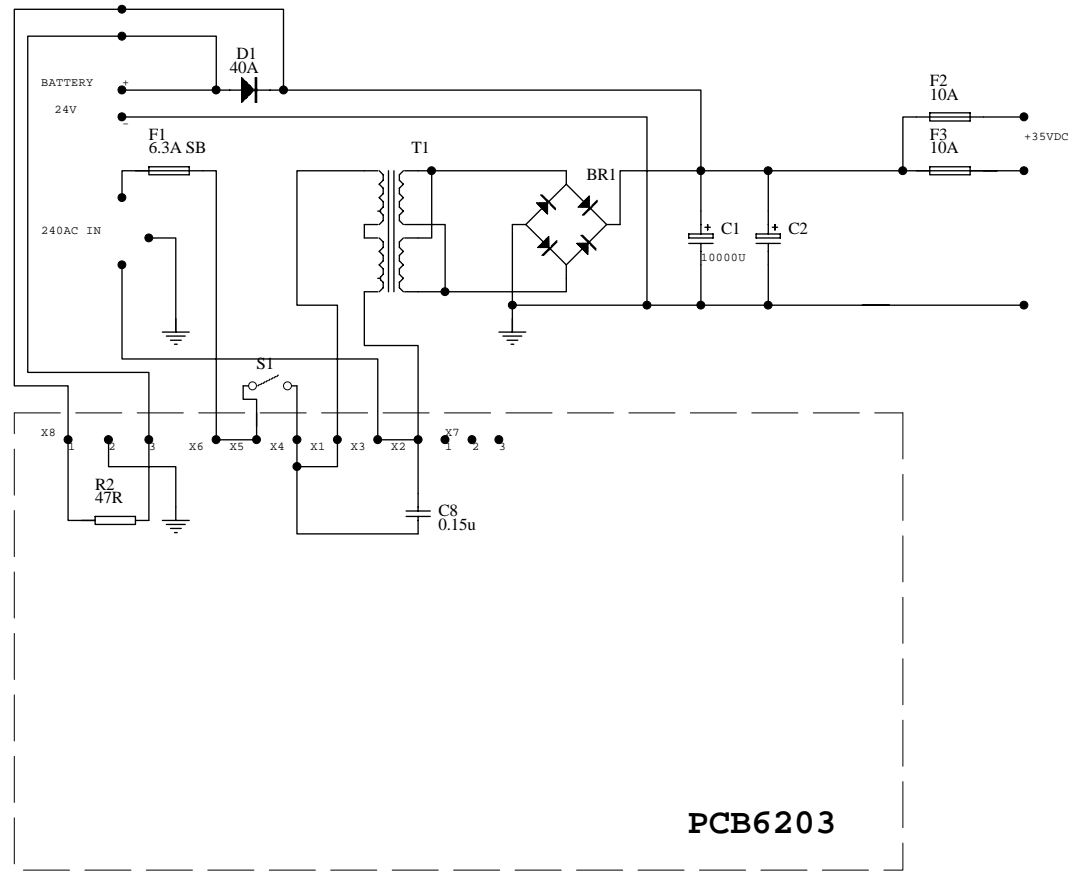

PCB6203

Title			DCM250 POWER SUPPLY		
Size	Number	Revision			
A3	CD6203-2	C			
Date:	6-May-2003	Sheet of	2	2	
File:	C:\DCM Manuals\CD6203-2.DDB	Drawn By:	SBG		

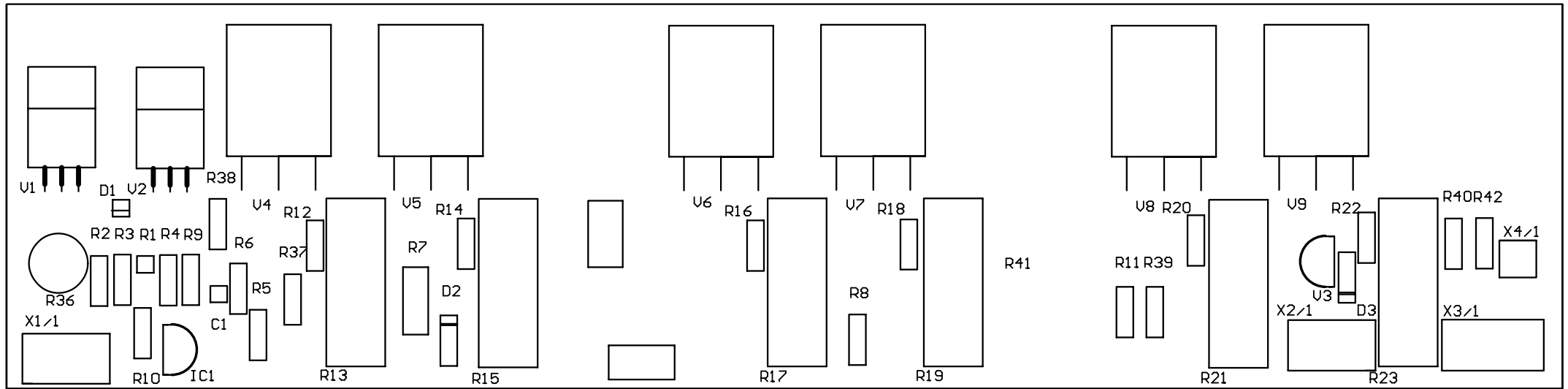

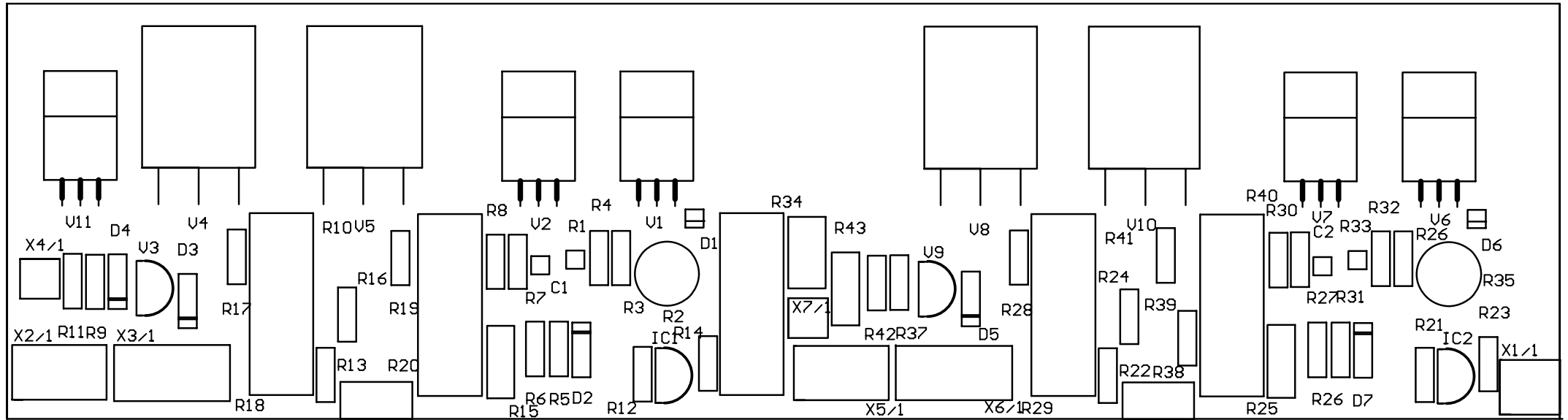

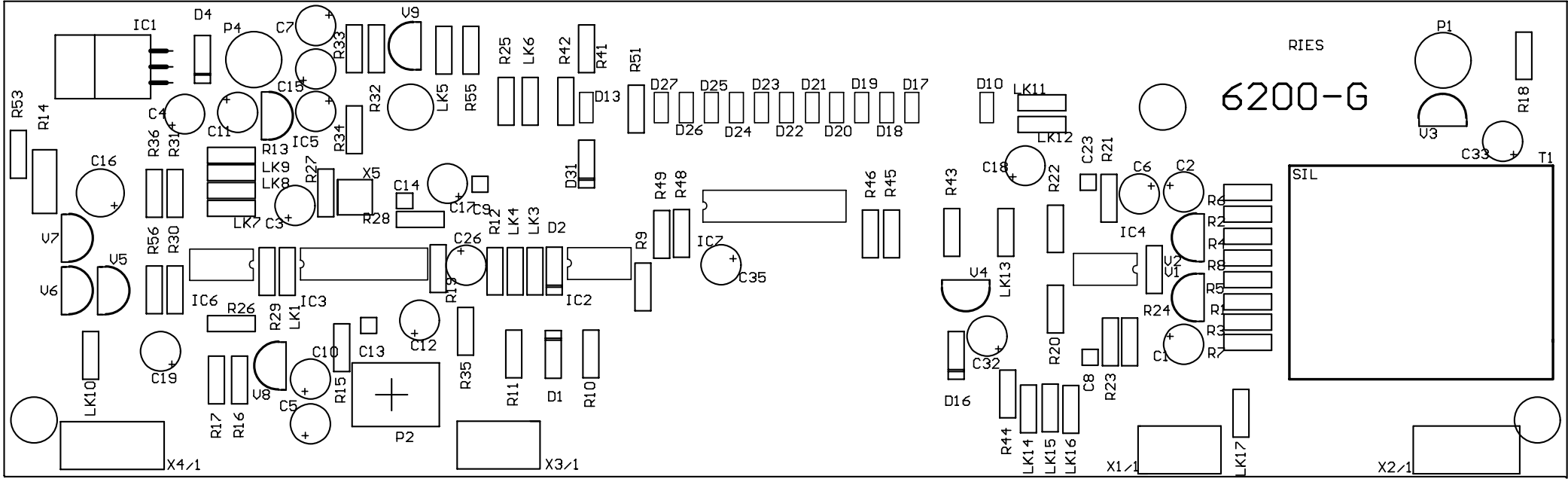

DCM250 Output Stage Component List

Designator	Part Type	Description
C1A	820P	Multi layer Ceramic capacitor
C1B	820P	Multi layer Ceramic capacitor
D1A	1N4007	Rectifier Diode
D1B	1N4007	Rectifier Diode
D2A	1N4007	Rectifier Diode
D2B	1N4007	Rectifier Diode
D3A	1N4007	Rectifier Diode
D3B	1N4007	Rectifier Diode
D4	1N4007	Rectifier Diode
IC1A	78L05	Voltage regulator TO92
IC1B	78L05	Voltage regulator TO92
R10A	1K	Resistor, metal film .5W
R10B	1K	Resistor, metal film .5W
R11A	4K7	Resistor, metal film .5W
R11B	4K7	Resistor, metal film .5W
R12A	2K2	Resistor, metal film .5W
R12B	2K2	Resistor, metal film .5W
R13A	R22	Wire wound resistor 5W
R13B	R22	Wire wound resistor 5W
R14A	2K2	Resistor, metal film .5W
R14B	2K2	Resistor, metal film .5W
R15A	R22	Wire wound resistor 5W
R15B	R22	Wire wound resistor 5W
R16A	2K2	Resistor, metal film .5W
R16B	2K2	Resistor, metal film .5W
R17A	R22	Wire wound resistor 5W
R17B	R22	Resistor, metal film .5W
R18A	2K2	Resistor, metal film .5W
R18B	2K2	Resistor, metal film .5W
R19A	R22	Wire wound resistor 5W
R19B	R22	Wire wound resistor 5W
R1A	220R	Resistor, metal film .5W
R1B	220R	Resistor, metal film .5W
R20A	2K2	Resistor, metal film .5W
R20B	2K2	Resistor, metal film .5W
R21A	R22	Wire wound resistor 5W
R21B	R22	Wire wound resistor 5W
R22A	2K2	Resistor, metal film .5W
R22B	2K2	Resistor, metal film .5W
R23A	R22	Wire wound resistor 5W
R23B	R22	Wire wound resistor 5W
R2A	220R	Resistor, metal film .5W
R2B	220R	Resistor, metal film .5W
R36A	500R	Cermet, preset horizontal
R36B	500R	Cermet, preset horizontal
R37	0R	Link, zero ohms
R38A	47k	Resistor, metal film .5W
R38B	47k	Resistor, metal film .5W
R39A	10R	Resistor, metal film .5W
R39B	4K7	Resistor, metal film .5W
R3A	220R	Resistor, metal film .5W

R3B	220R	Resistor, metal film .5W
R40	1K	Resistor, metal film .5W
R40B	1K	Resistor, metal film .5W
R41	80D	
R41A	100D	
R42B	10R	Resistor, metal film .5W
R4A	1K	Resistor, metal film .5W
R4B	1K	Resistor, metal film .5W
R5A	150R	Resistor, metal film .5W
R5B	150R	Resistor, metal film .5W
R6A	150R	Resistor, metal film .5W
R6B	150R	Resistor, metal film .5W
R7A	10R	Resistor, metal film .5W
R7B	10R	Resistor, metal film .5W
R8A	470R	Resistor, metal film .5W
R8B	470R	Resistor, metal film .5W
R9A	1K	Resistor, metal film .5W
R9B	1K	Resistor, metal film .5W
T2		
V16	TIP41C	Transistor TO220
V1A	TIP41C	Transistor TO220
V1B	TIP41C	Transistor TO220
V2A	IRF9520	Mosfet, Hexfet
V2B	IRF9520	Mosfet, Hexfet
V3A	BC556	Transistor TO92
V3B	BC556	Transistor TO92
V4A	TIP35C	Transistor TOP-3
V4B	TIP35C	Transistor TOP-3
V5A	TIP35C	Transistor TOP-3
V5B	TIP35C	Transistor TOP-3
V6A	TIP35C	Transistor TOP-3
V6B	TIP35C	Transistor TOP-3
V7A	TIP35C	Transistor TOP-3
V7B	TIP35C	Transistor TOP-3
V8A	TIP35C	Transistor TOP-3
V8B	TIP35C	Transistor TOP-3
V9A	TIP35C	Transistor TOP-3
V9B	TIP35C	Transistor TOP-3

DCM Series Drive Stage Component List

Designator	Part Type	Description
C1	2u2	Electrolytic Capacitor 35V
C10	2u2	Electrolytic Capacitor 35V
C11	22u	Electrolytic Capacitor 35V
C12	2u2	Electrolytic Capacitor 35V
C13	47P	Multi layer ceramic capacitor
C14	47P	Multi layer ceramic capacitor
C15	100u	Electrolytic Capacitor 16V
C16	100u	Electrolytic Capacitor 16V
C17	2u2	Electrolytic Capacitor 35V
C18	4u7	Electrolytic Capacitor 35V
C19	47u	Electrolytic Capacitor 35V
C2	2u2	Electrolytic Capacitor 35V
C20	47u	Electrolytic Capacitor 35V
C23	100P	Multi layer ceramic capacitor
C26	4u7	Electrolytic Capacitor 35V
C3	10u	Electrolytic Capacitor 35V
C32	4u7	Electrolytic Capacitor 35V
C33	4u7	Electrolytic Capacitor 35V
C35	4u7	Electrolytic Capacitor 35V
C4	2u2	Electrolytic Capacitor 35V
C5	2u2	Electrolytic Capacitor 35V
C6	2u2	Electrolytic Capacitor 35V
C7	100u	Electrolytic Capacitor 16V
C8	100P	Multi layer ceramic capacitor
C9	.47u	Metalised Poly Capacitor 63V
D1	1N4148	Rectifier Diode
D10	L-LED(red)	LED 3.0mm
D13	L-LED(red)	LED 3.0mm
D16	1N4148	Rectifier Diode
D17	L-LED(red)	LED 3.0mm
D18	L-LED(red)	LED 3.0mm
D19	L-LED(grn)	LED 3.0mm
D2	1N4148	Rectifier Diode
D20	L-LED(grn)	LED 3.0mm
D21	L-LED(grn)	LED 3.0mm
D22	L-LED(grn)	LED 3.0mm
D23	L-LED(grn)	LED 3.0mm
D24	L-LED(grn)	LED 3.0mm
D25	L-LED(grn)	LED 3.0mm
D26	L-LED(grn)	LED 3.0mm
D27	L-LED(grn)	LED 3.0mm
D31	1N4148	Rectifier Diode
D4	1N4007	Rectifier Diode
IC1	7815	Voltage regulator I.C TO220
IC2A	LM358	Comparator, dual IC DIP
IC2B	LM358	Comparator, dual IC DIP
IC3	SA571	Compander IC DIP
IC4A	LM833-A	Dual op-amp IC DIP
IC4B	LM833-B	Dual op-amp IC DIP
IC5	7805	Regulator IC TO92
IC6	PIC12C509	Programmable IC DIP

LK2	0R	Link, zero ohms
LK3	0R	Link, zero ohms
LK4	0R	Link, zero ohms
LK6	0R	Link, zero ohms
P1	2K	Cermet, preset Horizontal
P2	47K	Potentiometer 16mm
P4	10K	Cermet, preset Horizontal
R1	68K	Resistor, metal film .5W
R10	1K	Resistor, metal film .5W
R11	390R	Resistor, metal film .5W
R12	100R	Resistor, metal film .5W
R13	10K	Resistor, metal film .5W
R14	22R	Resistor, metal film .5W
R15	100K	Resistor, metal film .5W
R16	2M2	Resistor, metal film .5W
R17	47K	Resistor, metal film .5W
R18	1K	Resistor, metal film .5W
R19	100K	Resistor, metal film .5W
R2	68K	Resistor, metal film .5W
R20	10k	Resistor, metal film .5W
R21	39k	Resistor, metal film .5W
R22	10k	Resistor, metal film .5W
R23	10K	Resistor, metal film .5W
R24	10k	Resistor, metal film .5W
R25	10K	Resistor, metal film .5W
R26	10K	Resistor, metal film .5W
R27	2M2	Resistor, metal film .5W
R28	100K	Resistor, metal film .5W
R29	10K	Resistor, metal film .5W
R3	10K	Resistor, metal film .5W
R30	10K	Resistor, metal film .5W
R31	10k	Resistor, metal film .5W
R32	470K	Resistor, metal film .5W
R33	22K	Resistor, metal film .5W
R34	22K	Resistor, metal film .5W
R35	33K	Resistor, metal film .5W
R36	10K	Resistor, metal film .5W
R4	10K	Resistor, metal film .5W
R41	15K*	Resistor, metal film .5W
R41	12K**	Resistor, metal film .5W
R42	1K	Resistor, metal film .5W
R43	470R	Resistor, metal film .5W
R44	1K	Resistor, metal film .5W
R45	2K7	Resistor, metal film .5W
R46	1K2	Resistor, metal film .5W
R48	1K	Resistor, metal film .5W
R49	10K	Resistor, metal film .5W
R5	680R	Resistor, metal film .5W
R51	1K	Resistor, metal film .5W
R53	1K	Resistor, metal film .5W
R55	10K	Resistor, metal film .5W
R56	10K	Resistor, metal film .5W
R6	680R	Resistor, metal film .5W
R7	100R	Resistor, metal film .5W
R8	100R	Resistor, metal film .5W
R9	5K6	Resistor, metal film .5W

T1A	RF2285A	Driver Transformer
T1B	RF2285B	Driver Transformer
V1	BC639	Transistor TO92
V2	BC639	Transistor TO92
V3	BC546	Transistor TO92
V4	BC556	Transistor TO92
V5	BC546	Transistor TO92
V6	BC546	Transistor TO92
V7	BC546	Transistor TO92
V8	BC556	Transistor TO92
V9	BC556	Transistor TO92
	Please note	* DCM120-DCM500
	Please note	** DCM250