



This product is not DECT GAP compatible. It cannot be registered to any other DECT GAP telephone and it is not possible to register additional handsets.

This equipment is not designed for making emergency telephone calls when the power fails. Alternative arrangements should be made for access to emergency services.

This product is intended for connection to analogue public switched telephone networks and private switchboards in the United Kingdom.

BT Studio / Studio Twin
Digital Cordless Telephone

**User
Guide**

Please open this page for an 'At a glance' guide to your BT Studio.



At a glance

BT Studio Handset

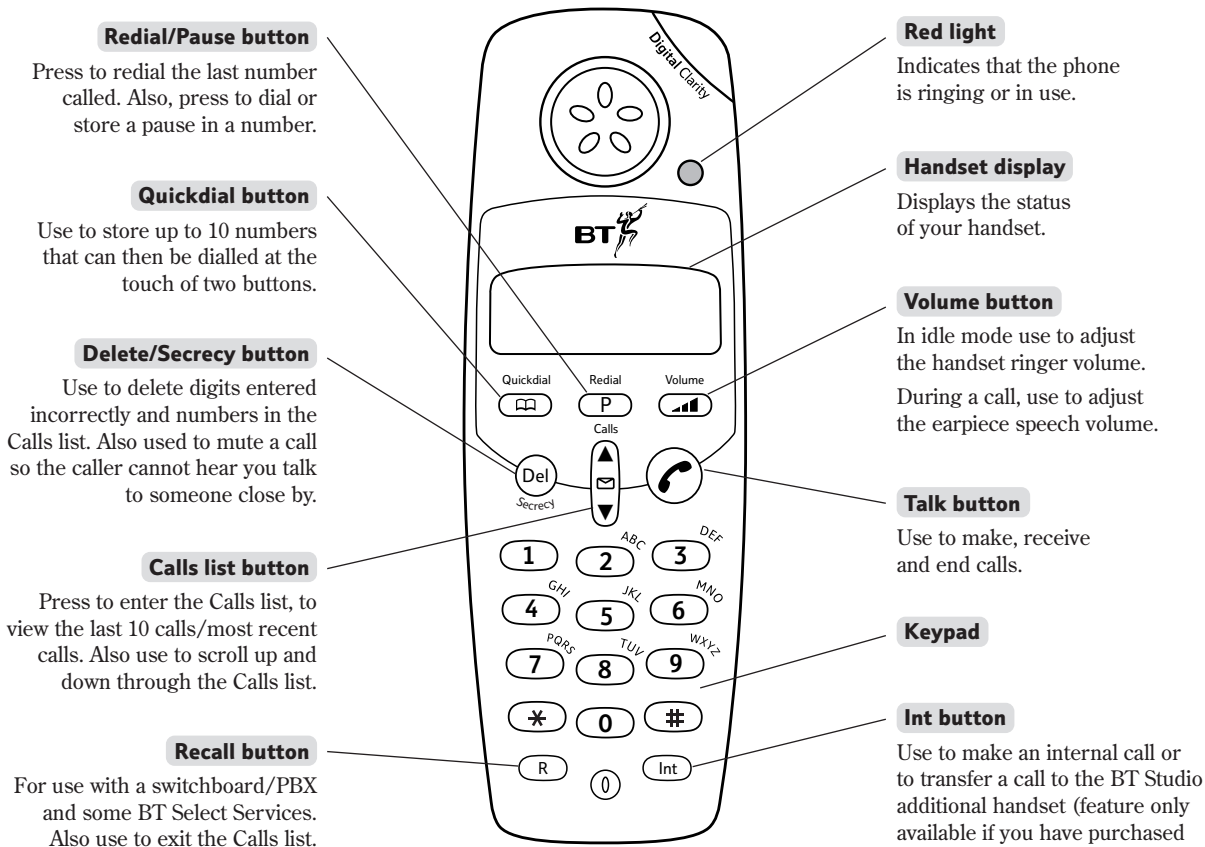

BT Studio Base

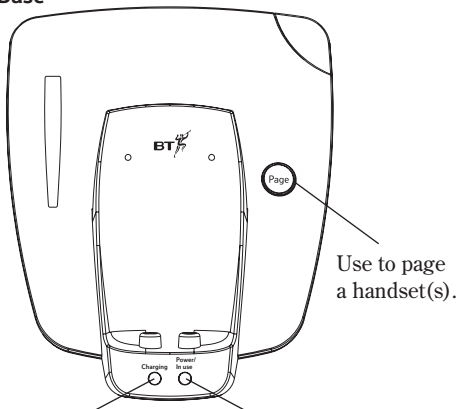

Charging light

Red light comes on when the batteries are being recharged.

Power/In use light

Green light comes on to indicate mains power. Flashes when the line is in use.

Additionally if you have purchased the BT Studio Twin

BT Studio Charger

Charging light

Red light comes on when the batteries are being recharged.

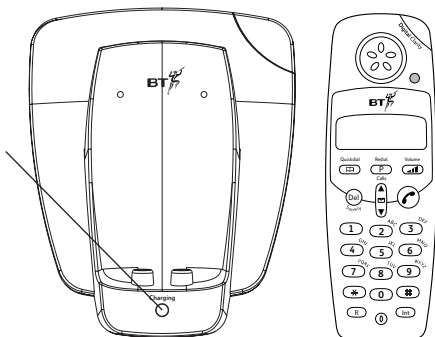

Quick guide to the handset display icons



Batteries are charged



Batteries are exhausted and require charging



Batteries are being charged

Switches off when batteries are fully charged



Handset is in use



Flashes to indicate an external incoming call

Steady during an external call



Flashes to indicate an internal call



Indicates you are dialling or storing a number in the Quickdial memory



Secrecy feature is switched on



Steady when viewing the Calls list

Flashes when a new call has been received in the Calls list



Steady when handset is in range of the base

Flashes when the handset is out of range of the base

In this guide

At a glance	1
Introduction	6
<i>Unpacking</i>	7
<i>For your records</i>	8
Safety information	9
Setting up	11
Using the telephone	18
<i>Making and receiving calls</i>	18
<i>Secrecy</i>	19
<i>Last number redial</i>	20
<i>Paging</i>	20
<i>Quickdial memory</i>	21
Caller Display	23
Handset settings	25
Using the BT Studio additional handset	26
<i>Internal calls</i>	26
<i>Transferring calls</i>	27
Help	28
General information	30
<i>Guarantee</i>	30
<i>Technical information</i>	31
<i>Switchboard compatibility</i>	31
<i>Switchboard external line access code</i>	32
<i>Setting pauses</i>	32
<i>Recall</i>	32
Index	33

Introduction

Your BT Studio is designed for ease of use and made to the high standards set by BT.

You can expect your BT Studio to provide many years of quality service. Please read the instructions carefully before use and keep this user guide for future reference.

DECT

By purchasing the Studio you now own a product which combines the advantages of cordless operation with the performance of a high quality corded telephone. It complies with the Digitally Enhanced Cordless Telecommunications (DECT) standard and offers unparalleled quality and features.

This user guide applies to both the Studio and Studio Twin telephones. Please note the Studio range of telephones are non GAP compatible. Please refer to page 26 for further information.

Unpacking your BT Studio or BT Studio Twin

Check that your BT Studio is complete. If anything is missing, please contact your place of purchase immediately.

BT Studio handset



BT Studio base station



Power supply for the base station
(Item code 872260)



Telephone line cord

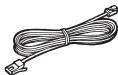

2 x AAA rechargeable batteries



Additionally if you have purchased the BT Studio Twin:

BT Studio Twin additional handset



BT Studio Twin charger



Power supply for the charger
(Item code 003313)



2 x AAA rechargeable batteries



For your records

Date of purchase:

Place of purchase:

Serial number:

(on the underside of the base station)

For guarantee purposes proof of purchase is required, so please keep your receipt.

Helpline

*If you have problems with your phone, please call the BT Studio Helpline on **08706 058 047**.*

Safety information

General

Only use the power supply included with the product. Using an unauthorised power supply will invalidate your guarantee and may damage the telephone. The item number for the base station is 872260. The item number for the charger is 003313 (only applicable if you have purchased the BT Studio Twin).

For the handset use only approved Nickel Metal Hydride (NiMH) rechargeable batteries. Never use other batteries or conventional alkaline batteries. They could lead to a short circuit or destroy the battery casing. Recommended batteries should have a power rating of 550mAh 1.2V. Batteries are available from the BT Studio Helpline **08706 058 047**.

Do not open the handset or base station. This could expose you to high voltages or other risks. Contact the helpline for all repairs.

Radio signals transmitted between the handset and base may cause interference to hearing aids.

It is recommended that advice from a qualified expert be sought before using this product in the vicinity of emergency/intensive care medical equipment.

It is recommended that if you have a pacemaker fitted you check with a medical expert before using this product.

Never dispose of batteries in a fire. There is a serious risk of explosion and/or the release of highly toxic chemicals.

Cleaning

Simply clean the handset and base station with a damp (not wet) cloth, or an anti-static wipe.

Never use household polish as this will damage the product.

Never use a dry cloth as this may cause a static shock.

Environmental

Do not expose to direct sunlight.

The product may heat up when the batteries are being recharged. This is normal. However, we recommend that you do not place the product on antique/veneered wood to avoid damage.

Do not stand your product on carpets or other surfaces which generate fibres, or place it in locations preventing free flow of air over its surfaces.

Do not submerge any part of your product in water and do not use it in damp or humid conditions, such as in bathrooms.

Do not expose your product to fire, explosive or other hazardous conditions.

There is a slight chance that your phone could be damaged by an electrical storm. We recommend that you unplug the power and telephone line cord for the duration of the storm.

Setting up

Follow these steps to set up your BT Studio ready for use.

Plan the location

Situate your product close enough to the telephone and mains power supply sockets so that the cables will reach.

Make sure the product is at least 1 metre away from other electrical products to avoid interference.

Do not place your BT Studio in the bathroom or other humid areas.

1 Connect the power supply cable

Plug the power supply cable into the power socket on your BT Studio base station (Item number 872260). The power light on the base will come on.

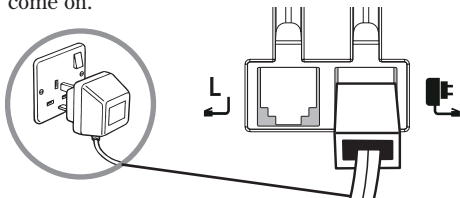

2 Plug the power supply adaptor into the wall socket

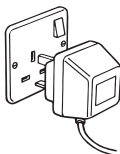

Warning

Do not connect the telephone line cord to the phone socket until your handset is fully charged. This will prevent the risk of the phone being answered before the batteries are charged. Answering the phone before the batteries are fully charged may prevent it from reaching its optimum capacity.

3 Insert the batteries

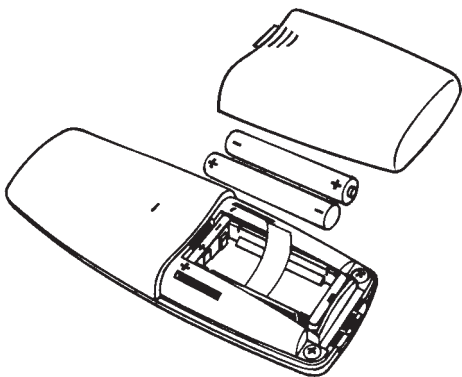



Insert the two batteries supplied, as indicated on the markings inside the battery compartment and slide the battery compartment shut. The handset display will show -1-. This means one handset is registered to the base. If you have purchased the BT Studio Twin the handset will show -2-. See page 15.

Warning

Under no circumstances should NiCad or non-rechargeable batteries be used. Only use the approved batteries. Using unapproved batteries will invalidate your guarantee and may damage the telephone.

4 Charge the handset batteries for at least 16 hours

Before you use your BT Studio for the first time it is important to have the handset batteries fully charged. Place the handset on the base station. You will hear a long beep. The red charging light on the base will come on and the battery and charging icon  will be displayed. Leave the handset to charge continuously for **at least 16 hours** to reach full charge.

The handset comes pre-registered but the  icon will flash to indicate that the handset is linking up with the base. Once link up is successful the  icon will stop flashing and remain steady.

IMPORTANT

The handset must always be placed on the base face up. The base station must be plugged into the mains power socket at all times.

Once the handset is fully charged, the charging icon  will be switched off.

Battery levels



Battery low warning

If the handset battery symbol is empty, you will hear a warning beep every 1 minute, you will need to recharge your handset before you can use it. The handset will only beep every minute when it is in use. In idle mode the empty battery icon is displayed.

Out of range warning

When the handset is in use and you go out of range of the base it will beep every 1 minute and the  icon will flash. Move closer to the base station.

Signal Strength

The BT Studio and BT Studio Twin have a range of up to 300 metres outdoors and up to 50 metres indoors. This is in ideal conditions.

Battery performance

Fully discharging the batteries at least once a week will help them last as long as possible. However, the charge capacity of rechargeable batteries will reduce with time as they wear out, so reducing the talk/standby time of the handset. Eventually they will need to be replaced. New batteries can be obtained from the BT Studio Helpline **08706 058 047**.

Note: Under ideal conditions, the handset batteries should give about 14 hours talktime or 350 hours standby on a single charge. Optimum times for talk and standby are only achieved when the handset batteries are fully charged.

The following instructions are only applicable if you have purchased the BT Studio Twin. If you purchased the BT Studio please skip to instruction number 7.

5 Insert the batteries into the BT Studio Twin

Insert the batteries into your BT Studio Twin handset as shown on page 12. The handset display will show -2- as it is already pre-registered as handset 2.

6 Connect and charge the BT Studio Twin handset

Plug the power supply cable into the power socket on your BT Studio charger (Item number 003313).

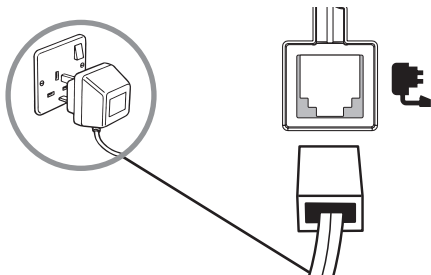

Plug the power supply adaptor into the wall socket.

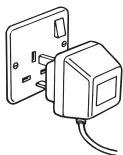

Place the handset onto the charger. The red charging light will come on and the charging icon will be displayed while the batteries are charging. Leave the handset to charge continuously for **at least 16 hours** to reach full charge.

7 Connect the telephone line cord to the base station

Plug the telephone line cord into the line socket on your base station.

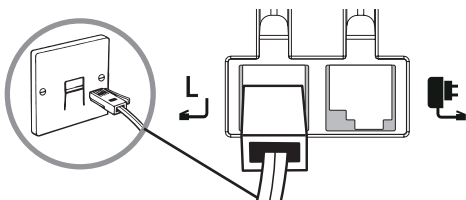

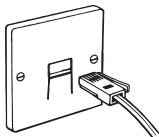
8**Connect the telephone line cord**

Your BT Studio/Studio Twin is now ready for use.

Helpline

*If you experience any difficulties installing or setting up your BT Studio, please contact the BT Studio Helpline on **08706 058 047**.*

Using the telephone

Making and receiving calls

To make an external call



Press the **TALK** button. You will hear the dial tone.

The  icon and EXT will be shown on the display and the In use light on the base will flash.



Enter the telephone number you want.

Or

Preparatory dialling

Enter the telephone number first and then check that it is correct on the display.



If you have made a mistake, press the **DELETE** button to delete any incorrect digits.



When you have entered the number correctly, press the **TALK** button to dial the number automatically.



Note

The first digit of a telephone number you enter or receive via Caller Display will not be shown on the display. For example the first 0 of 020 8123 4567 will not be displayed.

To end a call



Press the **TALK** button.

The  icon and EXT will disappear from the display and the In use light will stop flashing.

To receive a call

When the phone rings the EXT icon on the display will flash and the LED on the handset will also flash. If you subscribe to a Caller Display service the caller's telephone number will also be displayed.



Press the **TALK** button to answer the call.

Secrecy

When on a call you can talk to someone in the same room without your caller hearing.

To switch secrecy on/off

During a call:



Press the **SECRECY** button. The display will show the  icon. Your caller cannot hear you.



Press the **SECRECY** button again to resume your call.

Last number redial

Your handset automatically saves the last number you dialed. A redial number can be no longer than 20 digits.

To redial the last number dialed



Redial

P

Press the **TALK** button.

Press the **REDIAL** button. The last number you dialed will be shown on the display and dialed automatically.

Paging

You can page your handset (s) from the base station to alert a handset user that they are wanted or to locate a missing handset.

To page a handset

Page

Press the **PAGE** button on the base station.

The handset(s) will ring for 30 seconds.

To stop the handset(s) ringing, press any button on the handset.

Note

If you have purchased a Studio Twin you will need to press any button on the additional handset to stop that handset ringing.

Quickdial memory

You can store up to 10 of your most frequently used telephone numbers in the Quickdial memory. You can enter numbers up to 20 digits.

To store a number in the Quickdial memory

Quickdial



Press the **QUICKDIAL** button. The display will show the  icon.



Press the keypad number between **0** and **9** to select the location number under which you want to store the number.



Enter the telephone number you want to store. (You will hear a warning beep if you enter more than 20 digits)



If you enter any digits incorrectly you can press the **DELETE** button to delete them.

Quickdial



Press the **QUICKDIAL** button to confirm. You will hear a confirmation tone and the display will return to the idle mode.

Note

*Press the **R** recall button at any time to cancel a storing operation.*

To dial a number in the Quickdial memory



Press the **TALK** button.

Quickdial



Press the **QUICKDIAL** button.



Enter the location number **0** to **9** under which the number is stored.

The telephone number will be shown on the display and dialled.

Note

If you hear a warning beep when trying to dial a number in the quickdial memory it means there is no telephone number stored under that location number.

To delete a number in the Quickdial memory

Quickdial



Press the **QUICKDIAL** button.



Enter the location number **0** to **9** under which the number you wish to delete is stored.

Quickdial



Press the **QUICKDIAL** button. The number is now deleted.

(Alternatively, you can overwrite a number stored with a new number under the same memory location. Simply follow the *To store a number in the Quickdial memory* on page 21).



Caller Display

IMPORTANT

*To use Caller Display you must first subscribe to the service from your Network Provider. For more information on BT's Select Services call BT free on **0800 800 150**.*

Using Caller Display

If you have subscribed to your Network Provider's Caller Display Service you will be able to see your caller's number on your handset's display (provided it is not withheld) before you answer the call.

When someone calls you the  icon will be shown on the handset display. New calls in the Calls list are indicated by the  icon flashing. The caller's telephone number will then be stored in the Calls list whether you answer the call or not. If the telephone number is longer than 10 digits then the last 10 digits will be displayed.

Up to 10 telephone numbers can be stored in the Calls list. When the Calls list is full the oldest call will be replaced by a new call.

Note

Caller Display information not available

With some incoming calls the telephone number of the caller is not available and cannot therefore be displayed.

In this case, your BT Studio will show CALL instead of the caller's telephone number. The word CALL will not be stored in the calls list.

To view the Calls list

Calls



Press the **CALLS** button to enter the Calls list. The  will be displayed.

The most recent caller's telephone number will be displayed.



Use the **DOWN** button to scroll to the next number in the list and use the **UP** button to scroll back to the previous number.



To exit the Calls list at any time press the **R** button.

To dial a number from the Calls list



When viewing a number in the Calls list, press the **TALK** button. The number displayed will be dialed automatically.

To delete a number from the Calls list



When viewing a number in the Calls list, press the **DELETE** button. You will hear a confirmation tone and the number displayed will be deleted.

Handset Settings

To adjust the earpiece volume

You can only adjust the earpiece volume during a call. There are 3 earpiece volume levels to choose from: HIGH, LOW and MEDIUM.

During a call:

Volume



Press the **VOLUME** button until you reach the required volume level.

The volume will change from LOW, MEDIUM, HIGH and then repeat the sequence again, LOW, MEDIUM, HIGH.

To adjust the handset ringer volume

There are 3 ringer volume levels to choose from: HIGH, LOW and MEDIUM.

Volume



Press the **VOLUME** button until you reach the required volume.

The volume will change from HIGH, LOW, MEDIUM and then repeat the sequence again, HIGH, LOW, MEDIUM.

Using the BT Studio Twin additional handset

The BT Studio is NOT GAP compatible, therefore, it cannot be registered to any other DECT telephones. However, if you have purchased the BT Studio Twin you will have the BT Studio additional handset. Please note that this is the only handset that can be used with the main BT Studio base station. With the BT Studio Twin you can make internal calls and transfer external calls between the two BT Studio handsets.

The BT Studio additional handset comes pre-registered to the main BT Studio base station. It is supplied with its own charger and must be charged continuously for 16 hours before you can use it. Please see *Setting Up* on page 15 if you have not already done this.

Internal calls

You can make internal calls between your BT Studio Twin handsets.

To make an internal call

Int

Press the **INT** button.

The other BT Studio handset will ring and INT will be shown on the display to indicate that the call is internal. To answer the call they should press the **TALK** button.

To end the call, press the **TALK** button.

Transferring calls

You can transfer an external call to the other BT Studio Twin handset.

To transfer a call

During an external call:

Int

Press the **INT** button.



The other BT Studio handset will ring. The other user should press the **TALK** button to answer the call. You can now talk to each other.



To transfer the call, press the **TALK** button.

Int

If you decide not to transfer the call you can return to the caller by pressing the **INT** button.

Int

If the other handset user does not even answer the call you can return to the caller by pressing the **INT** button.

If the other handset user does not answer the call after 30 seconds you are automatically re-connected to the caller.

Help

No display appears

The batteries may be flat or dead.

Recharge or replace the batteries.

No dial tone

Is the telephone line cord plugged into the phone socket?

Check that the base station is connected to the mains power and switched on.

You cannot link up with the base station

Is the display flashing  icon?

The mains power cable may not be connected at the base or switched on.

Are you in range of the base station?

Move closer to the base station.

The batteries could be low or flat

Recharge or replace the batteries.

No ring on the handset

The ringer volume may be set too low for you. To adjust the volume, see page 25.

Check that the base station is plugged into the phone socket and the mains power and that the mains power is switched on.

Buzzing noise on my radio, TV, computer or hearing aid

Sometimes your BT Studio can interfere with other electrical equipment if it is placed too close.

It is recommended that you place your BT Studio at least one metre away from such appliances to avoid any risk of interference.

The BT Studio Twin charger does not appear to be working

Check that:

The power adaptor is properly plugged into the charger.

Your handset has slotted correctly into the charger.

The batteries are correctly fitted into the handset.

The base is plugged into a working socket and the socket is switched on.

Are you using the correct power adaptor?

BT Studio Twin charger adaptor is item number: 003313.

Caller's number is not displayed even though you have subscribed to a Caller Display Service.

The number has been withheld by the caller or is an international/unavailable number.

Helpline

*If you are still experiencing difficulties, please call the BT Studio Helpline on **08706 058 047**.*

Replacing the handset batteries

After a time, you may find that the handset batteries are running out of charge more quickly. This is a standard sign of wear and the batteries will need replacing.

For spare batteries please call the BT Studio Helpline on **08706 058 047**.

Note

BT accepts no responsibility for damage caused to your BT Studio by using any other type of batteries than those recommended on page 9.

General information

Guarantee

Your BT Studio is guaranteed for a period of 12 months from the date of purchase.

Subject to the terms listed below the guarantee will provide for the repair of, or at BT's or its agent's discretion, the option to replace the BT Studio, or any component thereof, (other than the batteries), which is identified as faulty or below standard, or as a result of inferior workmanship or materials. Products over 28 days old from the date of purchase may be replaced with a refurbished product.

The conditions of this guarantee are:

- The guarantee shall only apply to defects that occur within the 12 month guarantee period.
- Proof of purchase is provided.
- The equipment is returned to BT or its agent as instructed.
- This guarantee does not cover the batteries and any faults or defects caused by accidents, misuse, fair wear and tear, neglect, storm damage, tampering with the equipment, or any attempt at adjustment or repair other than through approved agents.
- This guarantee does not affect your statutory rights.

Within the 12 month guarantee period:

If you experience difficulty using the product, prior to returning your product, please read the Help section beginning on page 28, or contact the BT Studio Helpline for assistance:

Helpline **08706 058 047**, 9am to 5.30pm Monday to Friday.

In the unlikely event of a defect occurring, please follow the Helpline's instructions for replacement or repair.

Outside of the 12 month guarantee period:

If your product needs repair after the guarantee period has ended, the repair must meet the approval requirements for connection to the telephone network. We recommend that you contact BT's approved repair agent, TecLogic on 01672 564444 or a local qualified repairer.

Instructions for returning the product:

If the Helpline is unable to remedy your problem they will ask you to return the product. Where possible, pack the product in its original packaging. Please remember to include all parts, including line cords, power supply units, and the original batteries. (Please note that we cannot take responsibility for goods damaged in transit.) Please obtain and keep proof of posting from the Post Office.

Technical information

How many telephones can you have?

All items of telephone equipment have a Ringer Equivalence Number (REN), which is used to calculate the number of items which may be connected to any one telephone line. Your BT Studio has a REN of 1. A total REN of 4 is allowed, if the total REN of 4 is exceeded, the telephones may not ring.

With different telephone types there is no guarantee of ringing, even when the REN is less than 4.

Only use approved power supply, item number 872260 for the BT Studio base station. If you have purchased the BT Studio Twin, for the charger use only item number 003313.

Switchboard compatibility

This product is intended for use within the UK for connection to the public telephone network and compatible switchboards, which support tone dialling and timed break recall. If in doubt please consult your service provider.

Switchboard external line access code

You may need to enter an access code (e.g. **9**) in order to get an outside line. So that the switchboard has time to pick up an outside line, you may also need to add a Pause after the access code.

Setting pauses

To insert a pause in a stored number

With some switchboards, after dialling the access code you may have to wait for a moment while the switchboard picks up an outside line

Redial

P

If so, press the **REDIAL/PAUSE** button to insert a pause before entering the telephone number.

If you need to insert a pause into a telephone number you are storing in the memory, start storing the number, (*see page 21*) and where the pause is needed, press the **REDIAL/PAUSE** button.

Recall

To use the recall button

R

The **RECALL** button is of use when connected to some switchboards, ie. to transfer calls or for some BT Select Services or those services available via your network provider. It is only available when a call is in progress.

Index

At a glance	1	Make a call	18
Batteries		Paging	20
charging	13	Pause	32
insert	12	Phone socket	16
low warning	14	Power supply	11
performance	14	Preparatory dialling	18
replacing	29	Quickdial memory	21
Caller Display	23	delete a number	22
Calls		dial a number	22
end	19	store a number	21
external	18	Recall	32
internal	26	Receive a call	19
make	18	Redial	20
receive	19	Returning product	31
redial	20	Ringer	
secrecy	19	handset	25
transfer	27	Safety information	9
Calls list		Secrecy	19
delete a number	24	Setting up	11
dial a number	24	Switchboard compatibility	31
view	24	Switchboard external line access code	32
Charge handset	13	Technical information	31
Delete		Telephone line cord	16-17
Calls list numbers	24	Transfer a call	27
quickdial numbers	22	Volume	
Display icons	4	earpiece	25
Earpiece volume	25	handset ringer	25
Guarantee	30		
Help	28		
Helpline	8		
Internal call	26		
Location of product	11		

R&TTE

This product is intended for use within the UK for connection to the public telephone network and compatible switchboards.

This equipment complies with the essential requirements for the Radio Equipment and Telecommunications Terminal Equipment Directive 1999/5/EC.

Declaration of Conformance

Hereby, Suncorp Technologies, declares that this BT Studio is in compliance with the essential requirements and other relevant provisions of Directive 1999/5/EC.

The Declaration of Conformance for the BT Studio is published on the website <http://www.suncorptech.com/bt>



Offices worldwide

The telecommunications services described in this publication are subject to availability and may be modified from time to time. Services and equipment are provided subject to British Telecommunications plc's respective standard conditions of contract. Nothing in this publication forms any part of any contract.

© British Telecommunications plc 2002.
Registered Office: 81 Newgate Street, London EC1A 7AJ.
Registered in England No. 1800000.
BT Studio Issue 1 (05/02) 7
Designed by The Art & Design Partnership Limited.

