



Published Manual Number: MTCEXB01

- Specified Date: 20120411
- As-of Date: 20120411
- Access Date: 20120411
- Depth: Detail
- Custom: n/a
- Applicability: CEX
- Language Code: ENG01, Purpose: publication, Format: 1colA

General—

Electronic Coin Washer- extractor Control with Seven Formulas

Applicable Milnor® products by model number:

30010CGE 30015C4E 30015CGE 30022C4E 36021C4E

Preface

BICEUK01 (Published) Book specs- Dates: 20120411 / 20120411 / 20120411 Lang: ENG01 Applic: CEX

i. About This Manual

i. 1. Scope

This manual provides commissioning, operating, and troubleshooting instructions for washer-extractors in the Milnor® C_E model line. These machines are equipped with the Milnor® electronic seven formula coin washer-extractor control. See the installation manual for information on machine installation procedures and mechanical requirements. See the service manual for preventive maintenance, service procedures, and mechanical parts identification. See the schematic manual for electrical parts identification and electrical troubleshooting instructions.

i. 2. If this Manual Does Not Have the Necessary Data [Document BIUUUD17]

This manual has the best data that was available when your machine was made. If you cannot find the necessary data:

- **Are you looking for data about a component not made by Milnor® but used on your machine—for example, a motor or a brake caliper?** We usually do not put the instructions of component manufacturers in Milnor manuals. You can find some of these instructions in the part of the Milnor website that gives maintenance data (<http://www.milnor.com/tkbsearch18.asp>). You can also find instructions for many components on the manufacturers' websites.
- **Are you looking for data about a Milnor component on your machine that this manual does not give?** If we get better data or more data after the manual is available, we will add it to a newer version of the manual. Speak with the Milnor Customer Support group. They can give you newer instructions if they are available or help you if not.

i. 3. How to Identify this Manual and its Included Documents [Document BIUUUD13]



This document uses Simplified Technical English.
Learn more at <http://www.asd-ste100.org>.

Use the specifications on the front cover of this manual to identify this manual or the included documents. This section tells about these specifications.

Published manual number—The primary identification number for the manual.

Specified date—The first assembly date for the machine or change about which this manual gives data.

As-of date—The company makes new manuals about items that are not new. These new manuals will include data started before this date.

Access date—The date Milnor prepared the manual for its publication.

Depth—“Detail” manuals show the maximum available data. “Synopsis” manuals show the minimum necessary data. A manual with more data goes with a synopsis manual.

Custom—A value of “n/a” here shows that this manual applies to all machines identified on the inner front cover of the manual. Other values show the laundry name and a code for the specified machine.

Applicability—Each value here shows the machines or model numbers that this manual applies to. The inner front cover shows the full list of the applicable models. If this value is “not used,” this manual has a different function.

Language Code—The value here shows the language and dialect of this manual. “Eng01” shows that the manual uses United States English.

Refer to a **document** in this manual with all of the specifications shown on the front cover. Replace the published manual number with the document number.

i. 4. Trademarks [Document BIUUUD14]

i. 4.1. Trademarks of Pellerin Milnor Corporation—These words are trademarks of Pellerin Milnor Corporation:

Table 1: Trademarks

CBW®	E-P Plus®	Mentor®	MilTouch™	RinSave®
E-P Express®	ExactXtract®	Mildata®	PulseFlow®	Staph Guard®
	GreenTurn™	Milnor®	RecircONE™	

i. 4.2. Trademarks of Other Companies—These words are trademarks of other companies:

Table 2: Trademarks

Acronis®	IBM®	Microsoft Office XP®	Microsoft Access®	Siemens®
Atlas 2000®	Microsoft Windows 2000®	Microsoft Windows NT®	Microsoft Windows XP®	Seagate Crystal Reports®
		Yaskawa®		



— End of BICEUK01 —

ii. General Safety Requirements—Vital Information for Coin Laundry Owners/Managers and Employees

Notice 2: Important Safety Instructions—Read and save all instructions

The placard shown in [Figure 1](#) instructs laundry owners, their managers and employees about installing, maintaining, testing, and providing instructions to users for safe operation of the machine. The instructions on this placard and other general safety requirements are described in more detail following the figure.

Figure 1: Warning Placard for Owners, Managers, and Employees

 ADVERTENCIA	 WARNING
<p>Una máquina instalada incorrectamente, con fallo o en condiciones inseguras puede causar la muerte o lesiones graves.</p> <ul style="list-style-type: none"> • El propietario/administrador debe leer y comprender esta etiqueta y los manuales de la máquina antes de instalar, usar o dar servicio a esta máquina. • La máquina debe instalarse de acuerdo con el código eléctrico nacional que incluye la colocación de una caja de desconexión eléctrica a la vista desde la máquina. • Nunca permita el uso de esta máquina si ocurre alguna de las siguientes situaciones: <ul style="list-style-type: none"> – entrecierre inoperante de la puerta, – existe evidencia de un fallo. • Diariamente debe probar el contador de monedas y el entrecierre de la puerta. Vea las instrucciones en el manual. • Asegúrese de que los usuarios cumplan con todas las precauciones en las etiquetas de la máquina. • Si hace falta el manual comuníquese con Pellerin Milnor Corporation, Kenner, Louisiana. 	<p>An incorrectly installed, malfunctioning, or otherwise unsafe machine can result in death or serious injury.</p> <ul style="list-style-type: none"> • Owner/manager must read and understand this label and machine manuals before installing, using, or servicing this machine. • Machine must be installed in accordance with the National Electric Code, which includes locating an electrical disconnect box in sight of machine. • Never permit use of this machine with: <ul style="list-style-type: none"> – an inoperative door interlock, – any evidence of malfunction. • Test coin counter and door interlock daily. See manual for instructions. • Be sure users follow precautions on all machine labels. • Contact Pellerin Milnor Corporation, Kenner, Louisiana, if manual is missing.

01-10708A

Incorrect installation, neglected preventive maintenance, abuse, and/or improper repairs or changes to the machine can cause unsafe operation and personal injuries, such as multiple fractures, amputations, or death. The owner/manager is responsible for understanding and ensuring the proper operation and maintenance of the machine. The owner/manager must be familiar with the contents of all machine instruction manuals, and verify that the machine is operated as described in this manual and all other manuals pertaining to this machine. The owner/manager should direct any questions about these instructions to a Milnor® dealer or the Milnor® Customer Service department.

ii. 1. **Laundry Facility**



WARNING 3: To reduce the risk of fire, machine must be fastened or otherwise secured to an uncovered concrete floor.

Provide a supporting floor that is strong and rigid enough to support—with a reasonable safety factor and without undue or objectionable deflection—the weight of the fully loaded machine and the forces transmitted by it during operation. See [Section 1.2. “About the Forces Transmitted by Washer-extractors”](#) for more details. Provide sufficient clearance for machine movement.

The laundry facility must provide protection from the elements. **Do not install the machine where it will be exposed to the weather.**

As of this writing, the National Electrical Code requires a clearly marked electric disconnect switch within sight of the machine and no farther away from the machine than 50 feet. Local codes may have additional requirements.

You are urged to consult your licensed electrician and take immediate steps to comply if your installation does not meet the National Electrical Code requirement and/or local codes.

Under certain conditions, hydrogen gas may be produced in a hot water system that has not been used for 2 weeks or more. **Hydrogen gas is explosive.** If the hot water system has not been used

for such a period, before using a washing machine, turn on all hot water faucets and let the water flow from each for several minutes. This will release any accumulated hydrogen gas. As the gas is flammable, do not smoke or use an open flame during this time.

ii. 2. Maintenance

Ensure the machine is inspected and serviced in accordance with good practice and the preventive maintenance schedule. Replace belts, pulleys, bearing seals, etc. before they are severely worn. Do not permit inspection, service or maintenance by unqualified personnel.

- ii. 2.1. **The Danger from Operating a Damaged Machine**—The door interlock must permit the door to be opened for a short time after the start of the cycle then prevent it from being opened for the remainder of the cycle. **Test this mechanism daily**, as explained in [Section iv. “Daily Test of Door Interlock”](#).

Immediately investigate any evidence of impending failure and make needed repairs. Conditions indicating that service is required include, among others, leaking seals, valves, and hoses, motor or bearings making whining or grinding noises or becoming abnormally hot, and cracks or bends in the cylinder, shell, or frame.



WARNING 4: Multiple Hazards—Operating a damaged machine can kill or injure personnel, further damage or destroy the machine, damage property, and/or void the warranty.

- Do not permit the machine to be operated with any evidence of damage or malfunction.
- Do not disable any safety device or permit the machine to be operated with a malfunctioning safety device.



WARNING 5: Explosion Hazards—Cylinder—A damaged cylinder can rip apart during extraction, puncturing the shell and discharging metal fragments at high speed.

- Do not permit the machine to be operated with any evidence of damage or malfunction.

- ii. 2.2. **The Danger of Exposing Normally Guarded Hazards**—Every guard and access panel on the machine exists to isolate energized or moving parts from machine users and bystanders and must be securely in place for safe operation.



WARNING 6: Electrocution and Electrical Burn Hazards—Contact with high voltage will electrocute or burn you. High voltage is present at the machine unless the main machine power disconnect is off.

- Do not service the machine unless qualified and authorized. You must clearly understand the hazards and how to avoid them.
- Abide by the current OSHA lockout/tagout standard when lockout/tagout is called for in the service instructions. Outside the USA, abide by the OSHA standard in the absence of any other overriding standard.
- Replace guards and covers before returning the machine to service and do not permit the machine to be operated with guards or covers removed.



WARNING 7: Entangle and Crush Hazards—Contact with moving components normally isolated by guards, covers, and panels, can entangle and crush your limbs. These components move automatically.

- Do not service the machine unless qualified and authorized. You must clearly understand the hazards and how to avoid them.
- Abide by the current OSHA lockout/tagout standard when lockout/tagout is called for in the service instructions. Outside the USA, abide by the OSHA standard in the absence of

any other overriding standard.

- Replace guards and covers before returning the machine to service and do not permit the machine to be operated with guards or covers removed.



CAUTION 8: Burn Hazards—Contact with hot goods or machine components can burn you.

- Do not service the machine unless qualified and authorized. You must clearly understand the hazards and how to avoid them.
- Abide by the current OSHA lockout/tagout standard when lockout/tagout is called for in the service instructions. Outside the USA, abide by the OSHA standard in the absence of any other overriding standard.
- Replace guards and covers before returning the machine to service and do not permit the machine to be operated with guards or covers removed.

An attendant key is provided with the machine. This key permits an attendant to bypass the coin acceptor and start a wash program without coins. The key also provides access to the testing and maintenance functions described in “Testing and Troubleshooting” in the reference manual.



WARNING 9: Multiple Hazards—Only knowledgeable service personnel can safely perform the testing and maintenance functions provided by the attendant key. Unauthorized or unknowledgeable users can be seriously injured or killed.

- Never leave key in lock.
- Understand the consequences of using the testing and maintenance functions.

ii. 3. Disposal

The discarded machine must not pose an entrapment hazard. **Before disposal, remove the cylinder door.**

ii. 4. Customer Awareness

A customer safety placard on the machine alerts the customer to immediate hazards from misuse. The placard is illustrated and described in [Section iii. “The Customer Safety Placard—Vital Information for Coin Laundry Customers, Owners/Managers and Employees”](#). **Keep the safety placards clean so that the pictures and words are plainly visible. Replace placards immediately if lost or damaged.** See the “Safety Placard Use and Placement” page in the service manual to identify the placards and properly locate them on the machine.

Use whatever effective means are available, such as monitoring customer activity and posting signs prominently in the facility, to ensure a safe environment. Customers must understand:

1. the nature of the potential hazards,
2. how to avoid the hazards, and
3. what to do in the event of an emergency.

— End of BICEXS04 —

BICEXS05 (Published) Book specs- Dates: 20120411 / 20120411 / 20120411 Lang: ENG01 Applic: CEX

iii. The Customer Safety Placard—Vital Information for Coin Laundry Customers, Owners/Managers and Employees

Notice 10: Important Safety Instructions—Read and save all instructions.

The customer safety placard shown in [Figure 2](#) was affixed to your Milnor® machine in a location that is easily visible to customers. This placard warns customers who are about to use the

machine of hazards that can result from improper use. Safety placards help to ensure a safe work environment and, as with any other machine part, must be properly maintained. **Placards must be kept clean so that the pictures and words are plainly visible.** Placards must be replaced immediately if lost or damaged. See the “Safety Placard Use and Placement” page in the service manual to identify the placards and properly locate them on the machine.

Figure 2: Customer Safety Placard

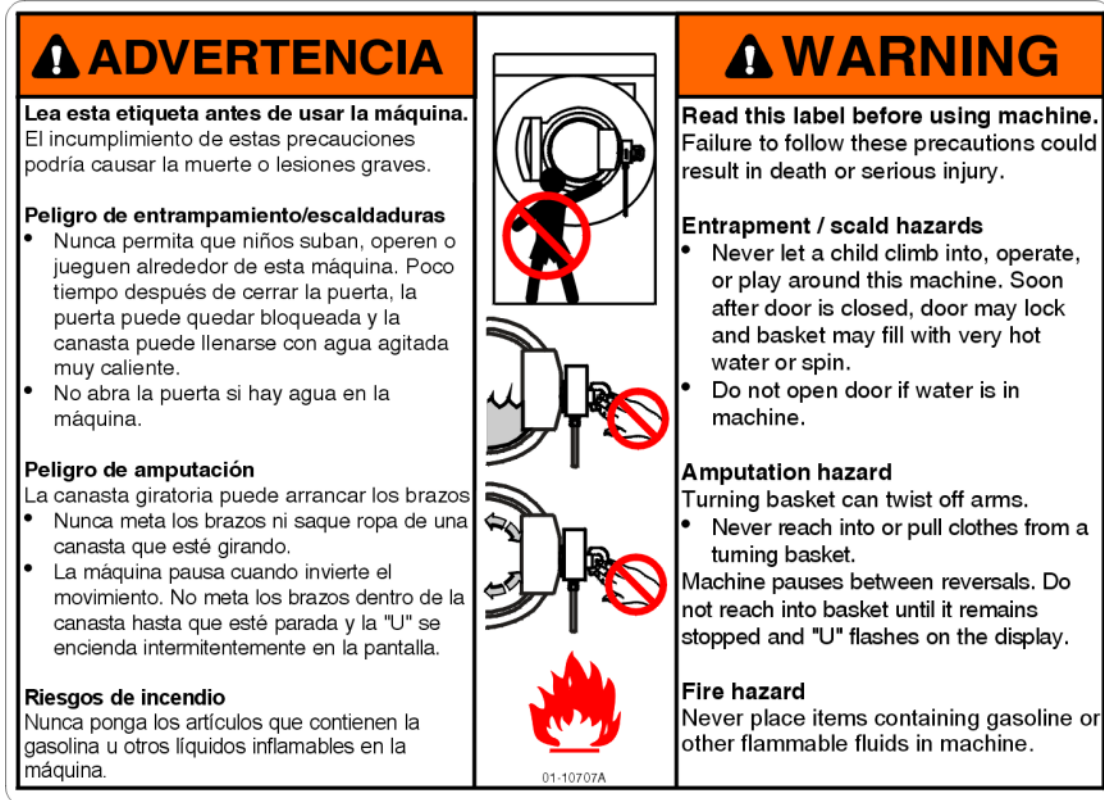

Laundry owners, managers and employees must familiarize themselves with these hazards and actively prevent any condition in their facility which might make accidents from these hazards more likely. These hazards are described in more detail below.

iii. 1. **The Danger of Child Entrapment and Scalding**

There have been child entrapment incidents with machines from various manufacturers. In each instance, a small child was placed, climbed, or was helped to climb into a front loaded coin machine and the door was closed behind him. The door locked, the machine started running, and in one instance, the child was scalded to death.



WARNING 11: Entrapment/Scald Hazards—

- Never let a child climb into, operate, or play around this machine. Soon after door is closed, door may lock and basket may fill with very hot water or spin.
- Do not open door if water is in machine.

Milnor® C_E coin operated washer-extractors have a door interlock. **As additional protection against entrapment, once the door locks, it may be unlocked by removing power at the wall-mounted disconnect switch or circuit breaker, which must be part of the installation.** The owner/manager must determine, based on laundry operation, how to best address such an entrapment emergency. For example, the owner/manager may wish to post clearly visible signs

alerting customers to this, or, if an attendant is always on duty, to make the attendant responsible for responding to such an emergency.

iii. 2. The Danger of Amputation Related to a Rotating Cylinder

A tremendous amount of energy exists in the rotating cylinder of any washer-extractor, even at slow speeds. If someone tries to pull goods from a turning basket, the goods can wrap around his/her arm, entangling the arm and twisting it off.



WARNING 12: Amputation Hazard—Turning basket can twist off arms.

- Never reach into or pull clothes from a turning basket.
- Machine pauses between reversals. Do not reach into basket until it remains stopped and “U” flashes on display.

To protect against child entrapment, the controller used on Milnor® C_E coin models permits opening the door during the first 60 seconds after closing the door and starting a wash program. The door locks after 60 seconds (see [Note 1](#)).

Note 1: During the first 60 seconds of the cycle, the door may be opened. If this occurs, the wash program halts, the drain valve opens immediately, the motor stops driving the basket, and—if the machine still has electric power—a brake is immediately applied to the basket. If the machine did not lose power, closing the door will cause the wash program to resume where it was interrupted and the door lock delay time to be reset so that the door can again be opened for 60 seconds from when the door was subsequently closed.

Once the door locks, it remains locked until one of the following conditions occurs:

- **the wash cycle ends normally**—When the wash cycle runs to completion without interruption, the door unlocks after the cycle ends and the safety delay time expires. The safety delay allows time for the machine to coast to a complete stop before allowing the user to open the door and retrieve the goods inside.
- **the machine loses power**—If power is lost during the wash cycle, the door unlocks to allow the user to open the door and retrieve the goods (see [Note 2](#)).

Note 2: A wash program interrupted by a power loss cannot be restarted. When power is restored and the door is closed, the customer can start the wash cycle from the beginning by inserting more coins, or the attendant can turn the *Attendant* switch to the horizontal position to allow starting the machine without coins.

iii. 3. The Danger from Flammable Materials



WARNING 13: Fire Hazard—Never place items containing gasoline or other flammable fluids in machine.

Washer-extractors are **not** designed to handle flammable materials. This includes goods containing flammable substances as well as flammable cleaning materials such as solvents. In either case, highly flammable vapors can be given off, especially when the material is heated. Any source of spark or flame, such as the machine's motor, can then ignite the vapors, resulting in fire or explosion. Additionally, washing with water and detergent may not fully remove flammable materials from the goods, posing a severe risk of fire when those goods are placed in a dryer.

— End of BICEXS05 —

iv. Daily Test of Door Interlock

The door interlock on Milnor® C_E models is designed to lock the door after the machine runs for approximately 60 seconds with the door closed. Test this vital safety mechanism daily to verify that it is functioning properly.

Notice 14: **Daily test of coin counter not required.**—This test, referred to in safety placards used on some older coin-operated models, is not required on current Milnor® C_E models. Current models require only the daily door interlock test.



CAUTION 15: **Scald Hazards**—Contact with hot bath liquor can scald you.

- During the following test, hold the door firmly closed as shown in [Figure 3](#) to prevent the door from springing open if the latch retracts during this test.

Figure 3: Hold Door Shut when Testing the Door Latch Interlock

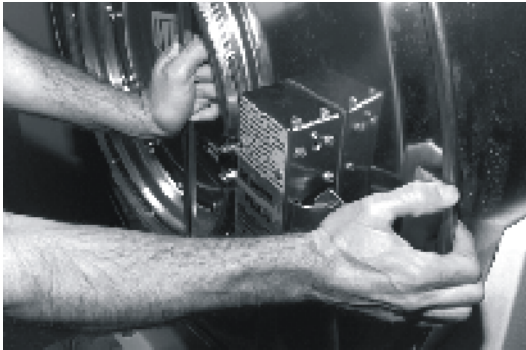

Use this procedure to verify that the door lock is working correctly:

1. Permit the wash program to progress for 90 seconds, but not much longer.
2. Holding the door closed, attempt to depress the door latch handle.
 - a. If the latch retracts (if the door unlocks), **remove the machine from service until the problem is identified and corrected.**
 - b. If the latch does **not** retract (if the door is locked), and assuming no other evidence of safety problems exists, return the machine to normal operation.

— End of BICEXS03 —

v. Contacting Milnor®

Your authorized Milnor dealer can assist you with any aspect of your Milnor machine and is familiar with local conditions that may be pertinent to its installation, use, or maintenance. Always contact your dealer first. Should you or your dealer need assistance from the Milnor factory, refer to [Table 3](#) for contact information.

Table 3: Pellerin Milnor Corporation Contact Information

Purpose	Department	Telephone	FAX	E-mail/Website
Order, or enquire about replacement parts	Parts	504-467-2787	504-469-9777	parts@milnor.com
Obtain advice on installing, servicing, or using	Customer Service/ Technical Support	504-464-0163	504-469-9777	service@milnor.com www.milnor.com (Customer Service)
Learn about, request, or enroll in Milnor service seminars	Training	504-712-7725	504-469-9777	training@milnor.com
Determine warranty eligibility or claim status	Warranty Administration	504-712-7735	504-469-9777	service@milnor.com (Attention: Warranty)
Ask about, comment on, or report an error in equipment manuals	Technical Publications	504-712-7636	504-469-1849	techpub@milnor.com

Your first contact with any question should be your authorized Milnor dealer, but problems or special situations encountered in the field may require consultation with the Milnor factory. Written correspondence can be mailed to this address:

Pellerin Milnor Corporation
 Post Office Box 400
 Kenner, Louisiana 70063-0400
 Telephone: 504-467-9591
<http://www.milnor.com>

— End of BIUUUK06 —

Table of Contents

Sections	Figures, Tables, and Supplements
Preface	
i. About This Manual (Document BICEUK01)	
i.1. Scope	
i.2. If this Manual Does Not Have the Necessary Data (Document BIUUUD17)	
i.3. How to Identify this Manual and its Included Documents (Document BIUUUD13)	
i.4. Trademarks (Document BIUUUD14)	
i.4.1. Trademarks of Pellerin Milnor Corporation	Table 1: Trademarks
i.4.2. Trademarks of Other Companies	Table 2: Trademarks
ii. General Safety Requirements—Vital Information for Coin Laundry Owners/Managers and Employees (Document BICEXS04)	Figure 1: Warning Placard for Owners, Managers, and Employees
ii.1. Laundry Facility	
ii.2. Maintenance	
ii.2.1. The Danger from Operating a Damaged Machine	
ii.2.2. The Danger of Exposing Normally Guarded Hazards	
ii.3. Disposal	
ii.4. Customer Awareness	
iii. The Customer Safety Placard—Vital Information for Coin Laundry Customers, Owners/Managers and Employees (Document BICEXS05)	Figure 2: Customer Safety Placard
iii.1. The Danger of Child Entrapment and Scalding	
iii.2. The Danger of Amputation Related to a Rotating Cylinder	
iii.3. The Danger from Flammable Materials	
iv. Daily Test of Door Interlock (Document BICEXS03)	Figure 3: Hold Door Shut when Testing the Door Latch Interlock
v. Contacting Milnor® (Document BIUUUK06)	Table 3: Pellerin Milnor Corporation Contact Information

Table of Contents

Chapter 1. Commissioning

1.1. Important Owner/User Information (Document BICEUK02)

- 1.1.1. Ensure Safety of All Personnel
- 1.1.2. Customize the Machine Controller

Sections	Figures, Tables, and Supplements
1.2. About the Forces Transmitted by Washer-extractors (Document BIWUUI02)	
1.2.1. Foundation Considerations	
1.2.2. How Strong and Rigid?	Figure 4: How Rotating Forces Act on the Foundation
1.3. Important Instructions for Pumped Chemical Inlets (Document BIWUUI01)	
1.3.1. How Pumped Chemical Systems can Internally Damage the Washer-extractor	Supplement 1: Preventing Dribbling by Purging Chemical Lines
1.3.2. Locating Chemical System Components to Reduce the Risk of Internal Damage	Figure 5: Proper Routing of Chemical Tubing
1.3.3. Preventing Leaks Which Can Injure Personnel and Cause External Damage	Figure 6: Rear-mounted Water Inlet Assembly (C_E Models) Figure 7: Optional C_E Rear-mounted Water and Liquid Supply Injector
1.4. Electrical Connections for Liquid Chemical Systems (Document BICEUI01)	
1.4.1. Pump Signal Connections	Table 4: Chemical Injection Signals Figure 8: Pump Signal Connections
1.4.2. <i>Timer Stop</i> Connections	
Chapter 2. Configuring	
2.1. Selecting the Formula Set and Setting the Coin Counts (Document BICEXC01)	
2.1.1. Selecting the Formula Set	Figure 9: Formula Set Switch
2.1.2. Setting the Default Wash Formula	
2.1.3. Coin Count Error Signal	
2.1.4. Setting the Coin Counts	Figure 10: 08BT128AT Processor Board Figure 11: Example Coin Count Settings Table 5: DIP Switch Settings for Coin Count Offset Table 6: DIP Switch Settings for Coin Counts
Chapter 3. Operating	
3.1. Control Panel (Document BICEX001)	Figure 12: C_E Control Panel
3.1.1. Control Functions During Normal Operation	
3.1.2. Control Functions in <i>Attendant</i> Mode	
3.2. Determining Load Size (Document BIWUU001)	
3.3. Using the Machine (Document BICEX002)	

Sections	Figures, Tables, and Supplements
3.3.1. Normal Operation (Coins Required)	Supplement 2: The Three-Compartment Supply Injector (Optional)
3.3.2. Attendant Operation (Attendant Key Required)	
3.3.3. Viewing and Clearing the Accumulator	
3.3.3.1. Viewing the Accumulator	Figure 13: Wash Cycle Accumulator
3.3.3.2. Clearing the Accumulator	
3.3.4. Error Recovery	Supplement 3: Recycle Sequence to Reduce Vibration During Extract
3.4. Standard Wash Cycles (Document BICEXP01)	Table 7: Standard Wash Cycles Table 8: GreenTurn™ Wash Cycles (available in WUMCR1A/200013 and later, and WUC4E1A/20010 and later) Table 9: Standard Coast and Delay Times (in seconds)
Chapter 4. Testing and Troubleshooting	
4.1. Error Codes (Document BICEXT01)	Figure 14: Error Code Display
4.1.1. How to Clear Error Conditions	Figure 15: <i>Normal</i> Position of Attendant Switch Figure 16: <i>Attendant</i> Position of Attendant Switch
4.1.2. Explanations of Error Codes	Table 10: Quick Reference for Error Codes Chart 1: Test to Prove Door is Properly Latched
4.2. Controller Inputs and Outputs (Document BICEXT02)	
4.2.1. Resuming Normal Operation	
4.2.2. Viewing Inputs	Figure 17: Viewing Inputs in <i>Attendant</i> Mode Table 11: Input Signals for Milnor C_E Coin Models
4.2.3. Actuating Outputs and Functional Tests	Table 12: Output Signals
4.2.4. Functional Tests	
4.2.4.1. Functional Test 12	
4.2.4.2. Functional Test 13	

Chapter 1

Commissioning

BICEUK02 (Published) Book specs- Dates: 20120411 / 20120411 / 20120411 Lang: ENG01 Applic: CEX

1.1. Important Owner/User Information

The following two procedures must be completed before this machine is placed in service:

1. Ensure the safety of all customers and laundry personnel.
2. Customize the machine controller for the desired number of coins per wash cycle.

1.1.1. Ensure Safety of All Personnel

Ensure that all personnel who will maintain this machine or oversee its operation read the safety documents in this manual before permitting them to access the machine. Ensure that all user manuals are available to the appropriate personnel and that all precautions explained in all applicable manuals are observed.

Always require that customers, employed attendants, and qualified maintenance technicians follow the safety guidelines in all applicable machine manuals. Allow only competent technicians with the proper training and qualifications to maintain or repair this machine.

1.1.2. Customize the Machine Controller

Customizing the controller in this machine consists of setting the seven banks of DIP switches on the micro-controller board for the desired coin count for each formula, as described in [Section 2.1. “Selecting the Formula Set and Setting the Coin Counts”](#). Always verify the coin count settings when the machine is first placed in service and any time the micro-controller board is replaced.

— End of BICEUK02 —

BIWUUI02 (Published) Book specs- Dates: 20120411 / 20120411 / 20120411 Lang: ENG01 Applic: CEX

1.2. About the Forces Transmitted by Washer-extractors

During washing and extracting, all washer-extractors transmit both static and dynamic (cyclic) forces to the floor, foundation, or any other supporting structure. During washing, the impact of the goods as they drop imparts forces which are quite difficult to quantify. Size for size, both rigid and flexibly-mounted machines transmit approximately the same forces during washing. During extracting, rigid machines transmit forces up to 30 times greater than equivalent flexibly-mounted models. The actual magnitude of these forces vary according to several factors:

- machine size,
- final extraction speed,
- amount, condition, and type of goods being processed,

- the liquor level and chemical conditions in the bath preceding extraction, and
- other miscellaneous factors.

Estimates of the maximum force normally encountered are available for each model and size upon request. Floor or foundation sizes shown on any Milnor® document are only for on-grade situations based only on previous experience without implying any warranty, obligation, or responsibility on our part.

1.2.1. Foundation Considerations

Size for size, rigid washer-extractors naturally require a stronger, more rigid floor, foundation, or other supporting structure than flexibly-mounted models. If the supporting soil under the slab is itself strong and rigid enough and has not subsided to leave the floor slab suspended without support, on grade installations can often be made directly to an existing floor slab if it has enough strength and rigidity to safely withstand our published forces without transmitting undue vibration. If the subsoil has subsided, or if the floor slab itself has insufficient strength and rigidity, a deeper foundation, poured as to become monolithic with the floor slab, may be required. Support pilings may even be required if the subsoil itself is “springy” (i.e., if its resonant frequency is near the operating speed of the machine). Above-grade installations of rigid machines also require a sufficiently strong and rigid floor or other supporting structure as described below.

1.2.2. How Strong and Rigid?

Many building codes in the U.S.A. specify that laundry floors must have a minimum live load capacity of 150 pounds per square foot (732 kilograms per square meter). However, even compliance with this or any other standard does not necessarily guarantee sufficient rigidity. In any event, it is the sole responsibility of the owner/user to assure that the floor and/or any other supporting structure exceeds not only all applicable building codes, but also that the floor and/or any other supporting structure for each washer-extractor or group of washer-extractors actually has sufficient strength and rigidity, plus a reasonable factor of safety for both, to support the weight of all the fully loaded machine(s) including the weight of the water and goods, and including the published 360-degree rotating sinusoidal RMS forces that are transmitted by the machine(s). Moreover, the floor, foundation, or other supporting structure must have sufficient rigidity (i.e., a natural or resonant frequency many times greater than the machine speed with a reasonable factor of safety); otherwise, the mentioned 360-degree rotating sinusoidal RMS forces can be multiplied and magnified many times. It is especially important to consider all potential vibration problems that might occur due to all possible combinations of forcing frequencies (rotating speeds) of the machine(s) compared to the natural frequencies of the floor and/or any other supporting structure(s). A qualified soil and/or structural engineer must be engaged for this purpose.

Figure 4: How Rotating Forces Act on the Foundation

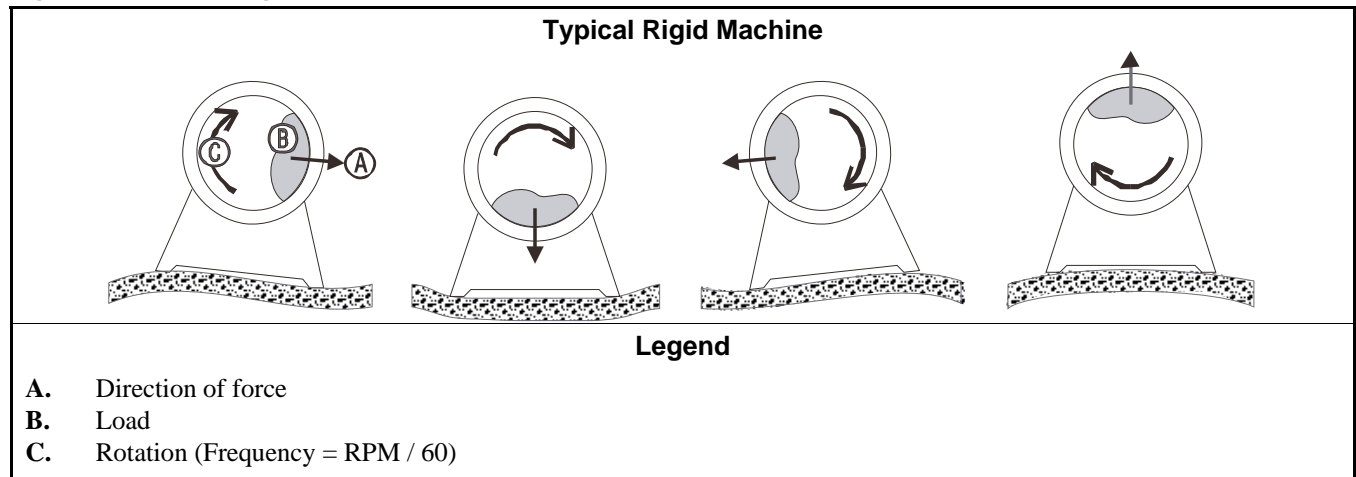

The figure(s) above depict(s) both on-grade and above-grade installations as well as models installed directly on a floor slab or on a foundation poured integrally with the slab. Current machine data is available from Milnor® upon request. All data is subject to change without notice and may have changed since last printed. It is the sole responsibility of every potential owner to obtain written confirmation that any data furnished by Milnor® applies for the model(s) and serial number(s) of the specific machines.

— End of BIWUUI02 —

BIWUUI01 (Published) Book specs- Dates: 20120411 / 20120411 / 20120411 Lang: ENG01 Applic: CEX

1.3. Important Instructions for Pumped Chemical Inlets

Although pumped liquid chemical supply systems are not common in coin laundry installations, this information applies to Milnor® electronic coin machine models equipped with optional connection points for such liquid supplies. Machines equipped with this option use the injector manifold illustrated in Figure 7. Machines equipped with the standard supply chute or three-compartment supply injector employ the water inlet manifold shown in Figure 6. See the service manual for an illustration of the three-compartment supply injector.

1.3.1. How Pumped Chemical Systems can Internally Damage the Washer-extractor

Many pumped liquid chemical systems dribble concentrated chemicals out of the injection tubes when the system is not used for relatively long periods of time—as after working hours and during weekends. This puts highly concentrated corrosive chemicals in direct contact with dry stainless steel surfaces, and often directly on any textiles left in the machine. **Chemical deterioration (rusting) of the stainless steel and damage to the textiles is the inevitable result.**

Pellerin Milnor Corporation accepts absolutely no responsibility whatsoever for damage to its equipment or to any textiles therein when concentrated chemicals dribble out of the injection tubes onto any part of the machine or its contents.

Supplement 1

Preventing Dribbling by Purging Chemical Lines

Although the injection site is flushed by washer agitation on some models and after each injection on other models to aid the injection process, this flushing provides absolutely no protection against harmful dribble which occurs later—when the machine is no longer in use.

One foolproof solution for “dribbling” is to completely purge the appropriate chemical injection tube with fresh water after every injection, so that only fresh water (which cannot cause a problem) can dribble out.

Obviously, it is the sole responsibility of the pump and/or chemical supplier (not the machine manufacturer) to furnish such a flushing device. (We understand that such flushing type chemical injection systems—both for retrofit to existing systems and for new installations—are now offered by others.)

1.3.2. Locating Chemical System Components to Reduce the Risk of Internal Damage

If the tubes, pumps, and chemical tanks are kept well below the injection point, the likelihood of “after-hours dribbling” is reduced, but not totally eliminated.

We therefore urge that tubes from any non-flushing pumped chemical system be connected as shown in Figure 5. Although fresh-water flushing the just-used tubes after each injection would be better, we believe routing the tubes as indicated will probably minimize the dribbling effect about as much as possible without flushing. Never permit tanks, pumps, or any portion of the tubes to be higher than the injection point. If loops in the injection tubes are employed, make sure the entire loop is well below the injection point.

Figure 5: Proper Routing of Chemical Tubing

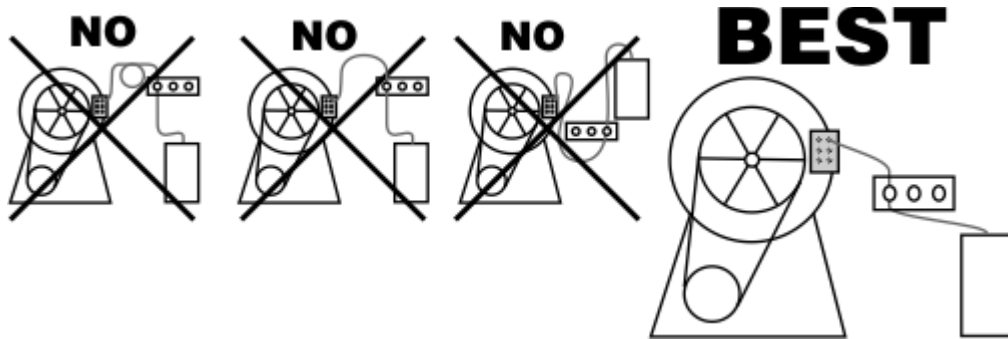

Note 3: As shown in Figure 5, all tanks, pumps, and tubing must be lower than the injection point on the machine and must not dribble chemicals into the machine, nor leak chemicals externally onto any portion of the machine or its surroundings.

1.3.3. Preventing Leaks Which Can Injure Personnel and Cause External Damage

Any ports on the inlet are plugged at the Milnor® factory. When replacing plugs with fittings or when reinstalling plugs, always use the sealant furnished (LocTite® RTV Silicone Adhesive or equivalent). Use properly sized hose barbs, always use clamps, and check for leaks. Use the hose barbs furnished with your machine only if they provide the proper fit for the tubes employed. Ensure that excessive pressures cannot build up that might burst or disconnect tubing. Instruct the operator to monitor for leaks and report any occurrences.

When calibrating injections, it is permissible to remove tubes from barbed fittings to take samples. However, always check for leaks after installing tubes and clamps. A preferable method for sampling is to install a three-way valve, or two two-way valves and a tee fitting, onto each injection tube.



WARNING 16: Avoid chemical burns and corrosion—Concentrated liquid chemicals leaking from a chemical system can burn skin and eyes, cause other types of injury or illness, and corrode machine components.

- Ensure that excessive pressures cannot build up which might burst or disconnect a chemical delivery tube.
- Ensure that there are no external chemical leaks when the system is installed or calibrated.
- Periodically check the system for leaks during operation.



CAUTION 17: Avoid corrosion and textile damage—Chemicals dribbling into the machine when it is idle will corrode machine components and damage any textiles left in the machine.

- If possible, use a system that flushes the entire chemical delivery tube after each injection.
- If a non-flushing system is used, install tanks, pumps, and tubing below the injection point on the machine, such that chemicals travel to the machine at an upward angle.



CAUTION 18: Avoid explosions—Certain chemicals will react chemically when combined. Consult with your chemical supplier representative about the safe use of chemicals.

Figure 6: Rear-mounted Water Inlet Assembly (C_E Models)

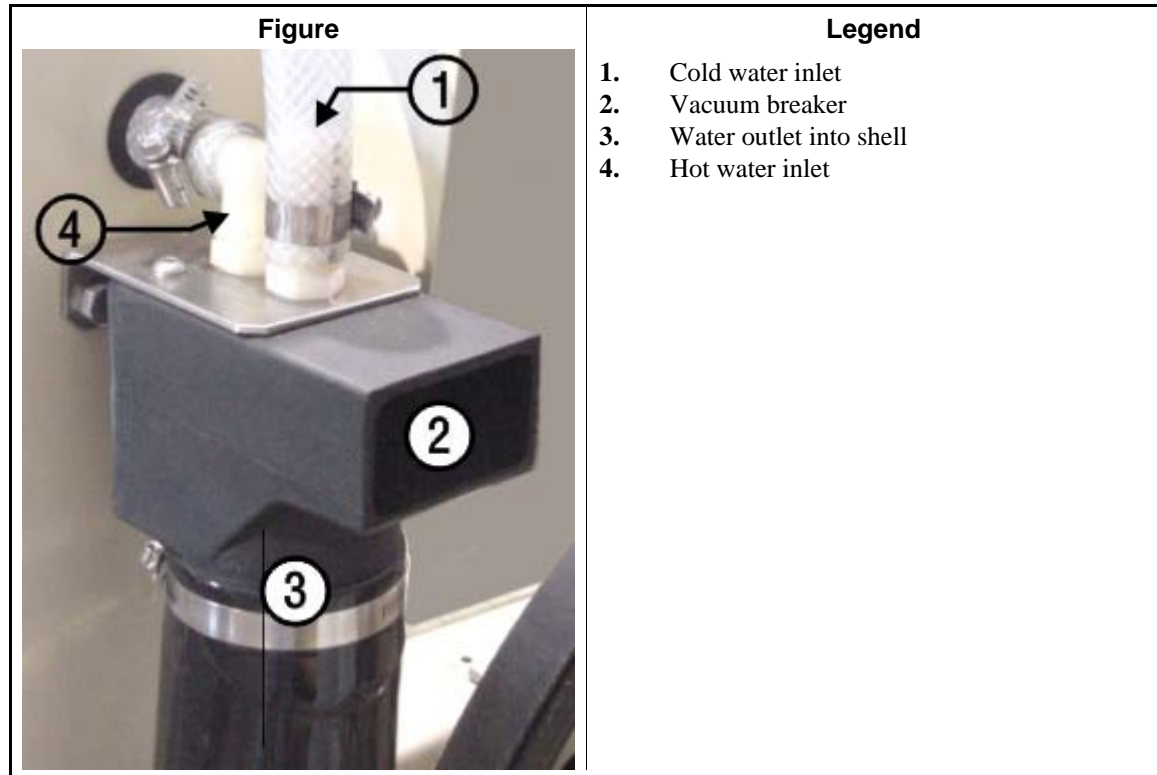
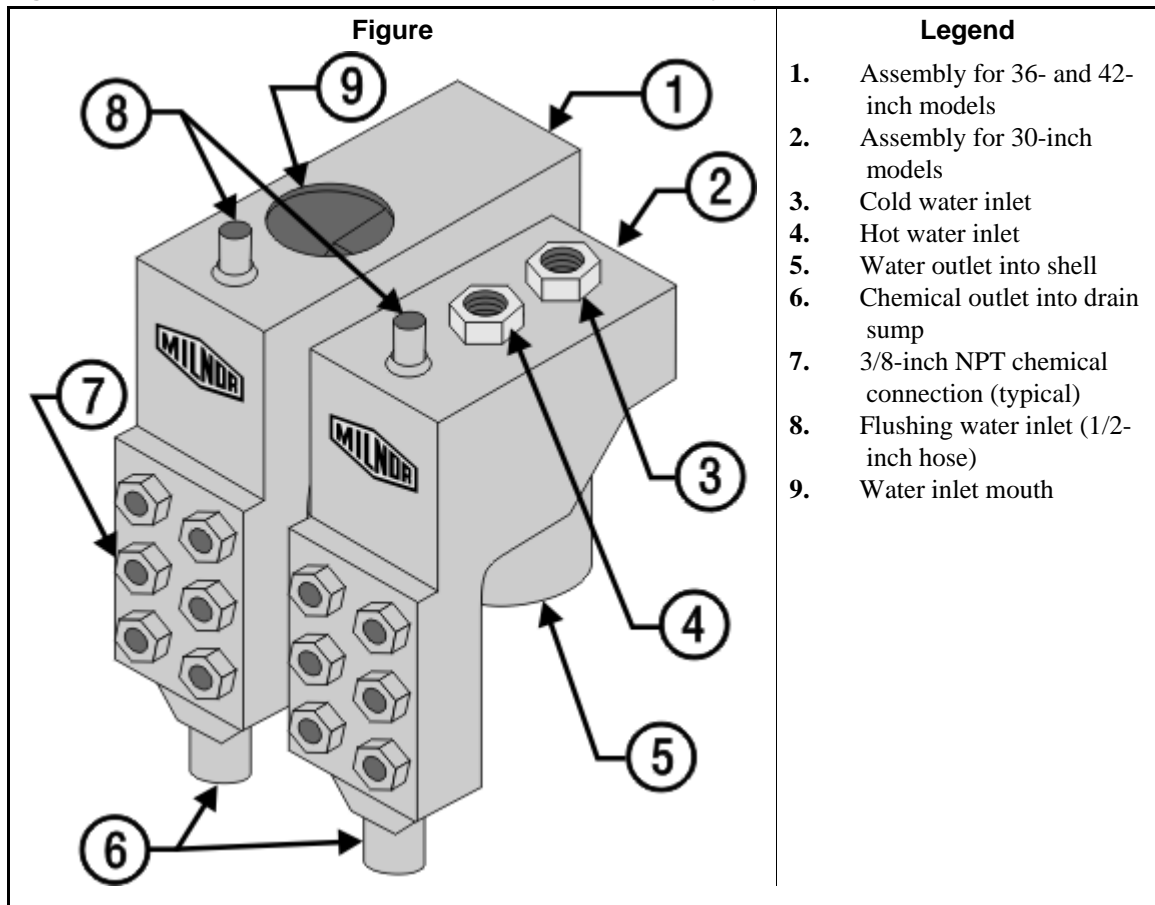

Figure 7: Optional C_E Rear-mounted Water and Liquid Supply Injector



Notice 19: Pellerin Milnor Corporation accepts absolutely no responsibility for damage to its equipment or to any textiles therein when concentrated chemicals dribble out of the injection tubes onto any part of the machine or its contents.

— End of BIWUI01 —

1.4. Electrical Connections for Liquid Chemical Systems



WARNING 20: Electric Shock Hazard—Contact with high voltage electricity will kill or seriously injure you. Even when the machine is not running, three-phase power and control circuit power are still present at several locations within the cabinet and at some electrical components.



CAUTION 21: Injury and Damage Hazards—Improper wiring can cause the machine to malfunction, risking injury to personnel, damage to machine components, and damage to goods.

- Electrical and piping connections described in this section must be made only by qualified, authorized personnel.
- Lock off and tag out power at the external disconnect switches for the washer-extractor before proceeding.
- Do not rely merely on the information in this section when wiring. Consult all applicable electrical schematics.

- Do not reroute or rearrange any wires not specifically permitted by this instruction.
- Do not connect a common wire to ground. Use the common terminal furnished.

1.4.1. Pump Signal Connections

The microprocessor controller used on Milnor® C_E models closes certain relay contacts when chemicals are desired. These signals are alternating current at the control circuit voltage and cannot be made potential-free. Any device driven by this signal can draw up to 37 milliamperes.



CAUTION [22]: Component Damage Hazard—Board components will burn out and require board replacement if devices driven by inject signals do not meet the above electrical specifications. Pumps usually draw a higher current than specified above, and will cause board damage.

This machine provides signals for three chemicals. [Table 4](#) contains the connection details for these signals. All chemical signal connections are available on terminal strip TBS, as shown in [Figure 8](#). This terminal strip is located in the electrical enclosure on the left rear of the machine, where the machine power connections are made.

Table 4: Chemical Injection Signals

Signal Component	Chemical	Relay	Processor Board Connection	TBS Terminal Number
Chemical 1	Detergent	K10	MTA6-3, 4	1
Chemical 2	Bleach	K09	MTA6-7, 8	2
Chemical 3	Fabric softener	K08	MTA6-9, 10	3

Figure 8: Pump Signal Connections

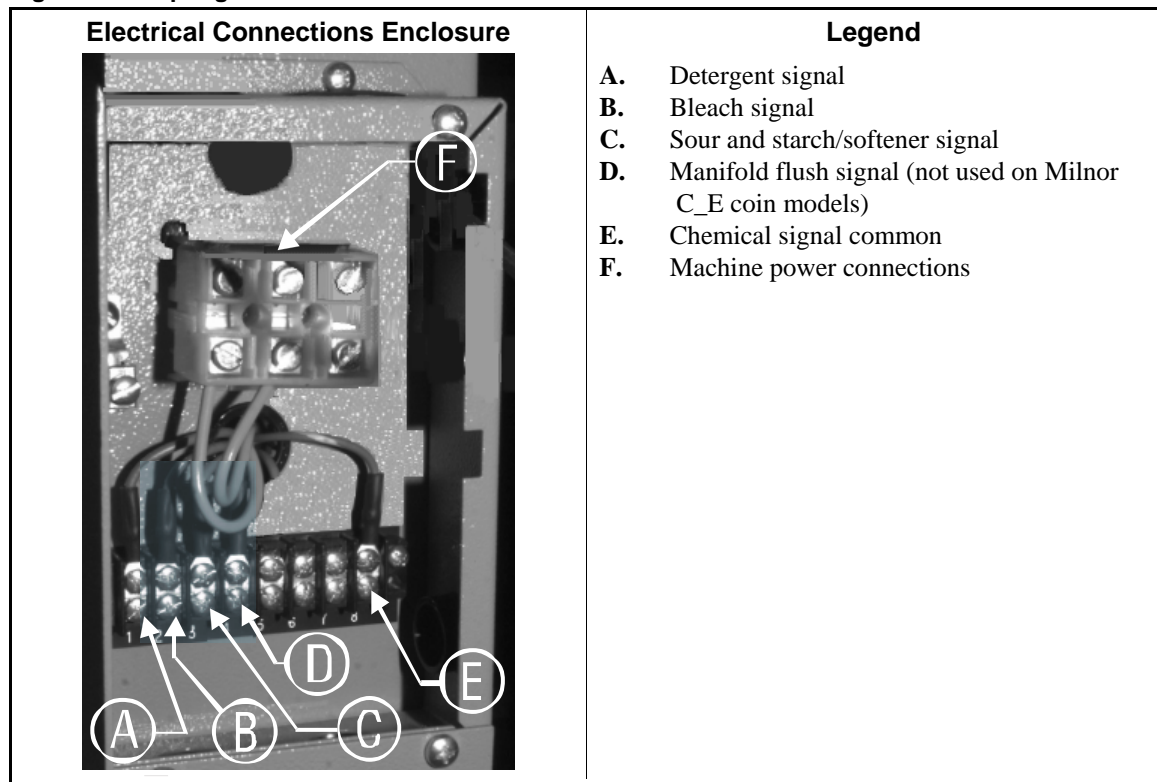

1.4.2. ***Timer Stop Connections***

Timer stop is not available on machines using the Milnor® C_E controller.

— End of BICEUI01 —

Chapter 2

Configuring

BICEXC01 (Published) Book specs- Dates: 20120411 / 20120411 / 20120411 Lang: ENG01 Applic: CEX

2.1. Selecting the Formula Set and Setting the Coin Counts

Coin-operated washer-extractor models in the Milnor® C_E line with software versions 20010 and later provide 2 sets of 7 pre-programmed wash cycles that can be selected by the user. The machine owner configures the machine for either the standard or alternate formula set, and the customer selects the desired formula from the configured set. DIP switch settings on the machine processor board (see [Figure 10](#)) determine the set of formulas from which the user can choose and the number of quarters required for each wash cycle.

Tip: Machines in this model line may be equipped with an optional coin counter mechanism which accepts both quarters and other denominations, including bills. All machines display the number of **quarters** required for the selected wash cycle, so the required coin (quarter) count decreases by four when a customer deposits a dollar coin or bill in the appropriate slot.

2.1.1. Selecting the Formula Set

Software versions 20010 and later provide 2 sets of wash formulas: a set of 7 standard formulas and a set of 7 alternate formulas. Only one set can be enabled at any time, and customers choose from the enabled formula set.



WARNING 23: Electrocution and Electrical Burn Hazards—Contact with high voltage will electrocute or burn you. High voltage is present at the machine unless the main machine power disconnect is off.



WARNING 24: Entangle and Sever Hazards—Guards, covers, and panels—Operating the machine with any guard, cover, or panel removed exposes moving components.

1. **Turn off power to the machine.** Because the micro-controller checks the DIP switch positions only during power-up, any changes made with power applied to the machine will not take effect until machine power is cycled off and on.
2. Referring to [Section 3.4. “Standard Wash Cycles”](#), determine which set of formulas will be available to customers.
3. Set position 6 of DIP switch 1 ON to use the standard formulas, or set the switch OFF to use the alternate formula set.

Tip: The standard formulas are detailed in [Table 7](#), and the GreenTurn™ formulas are detailed in [Table 8](#).

Figure 9: Formula Set Switch

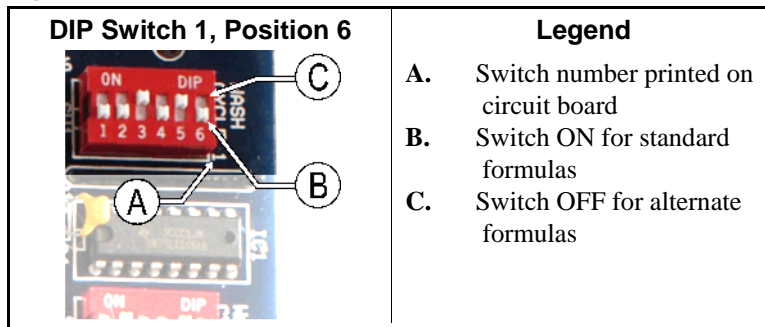

2.1.2. Setting the Default Wash Formula

The *default wash formula* is the formula that is pre-selected to run if the user does not select a formula before pressing the *Start* button. For example, machine owners may set the default formula to Formula 3 (Cold Wash) to reduce utilities costs or to Formula 6 (Quick Wash) to increase the number of cycles per day. The customer can always select another formula with the *Select* button.

You can set the default wash formula with the *Select* button during the power-up delay.

1. Remove and restore machine power. The default wash formula can only be set during the power-up delay.
2. The control displays the software version for seven seconds, then displays the seconds remaining in the power-up delay.
3. While the power-up delay countdown is active, press the *Select* button to display the desired default wash formula.

The default wash formula resets to Formula 1 (Hot Wash) when machine power is interrupted.

2.1.3. Coin Count Error Signal

Machines equipped with a coin slot mechanism signal an error if a coin is detected in the coin chute for too long. This would be a nuisance on machines with a coin slide mechanism instead of a coin slot. To disable the coin count error signal, set DIP switch SW2-6 to the OFF position.

2.1.4. Setting the Coin Counts

Use this procedure to set the number of quarters required for each wash cycle:



WARNING 25: Electrocution and Electrical Burn Hazards—Contact with high voltage will electrocute or burn you. High voltage is present at the machine unless the main machine power disconnect is off.



WARNING 26: Entangle and Sever Hazards—Guards, covers, and panels—Operating the machine with any guard, cover, or panel removed exposes moving components.

1. **Turn off power to the machine.** Because the micro-controller checks the DIP switch positions only during power-up, any changes made with power applied to the machine will not take effect until machine power is cycled off and on.
2. Referring to [Section 3.4. “Standard Wash Cycles”](#), determine the number of quarters desired to run each wash cycle.

- Referring to [Table 5](#), set the coin count offset.

Tip: The coin count offset is the number of coins added to the configured price for each wash cycle. The offset sets the minimum number of coins required for any wash cycle. For example, if you set the coin count offset for 8 coins and the coin count for a wash cycle to 6 coins, the vend price for that wash cycle is 14 coins. The maximum range between the price of the lowest priced wash cycle and the highest priced wash cycle is 31 coins (\$7.75 in US quarters).

- In [Table 6](#), look up the DIP switch settings which correspond to the desired quarter count for each wash cycle. In the table, “0” represents a switch position that is **OFF** and “1” represents a switch position that is **ON**.

Figure 10: 08BT128AT Processor Board

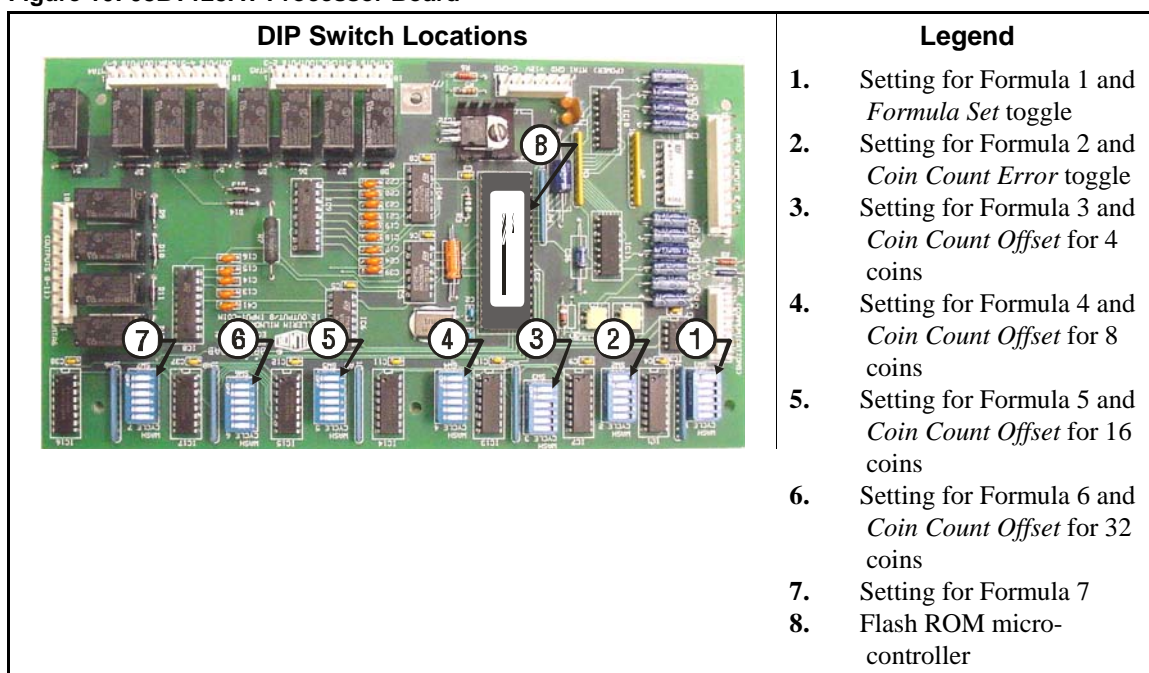

- On the machine processor board, set the DIP switch for Formula 1 to the value established from [Table 6](#).

Tip: As shown in [Figure 11](#), to set a switch position **OFF**, depress the side of the switch nearer the word “OFF” until it clicks. To turn a switch position **ON**, depress the side of the switch nearer the position number. Note the DIP switch labels on the processor board and the position numbers on the DIP switches.

- Set the desired coin (quarter) count values for the remaining wash cycles. This value is added to the *Coin Count Offset*.
- Apply power to the machine to resume service.
- Press the *Select Wash Cycle* button to select each wash cycle while observing the value displayed in the *coin count* window to verify each value.

Figure 11: Example Coin Count Settings

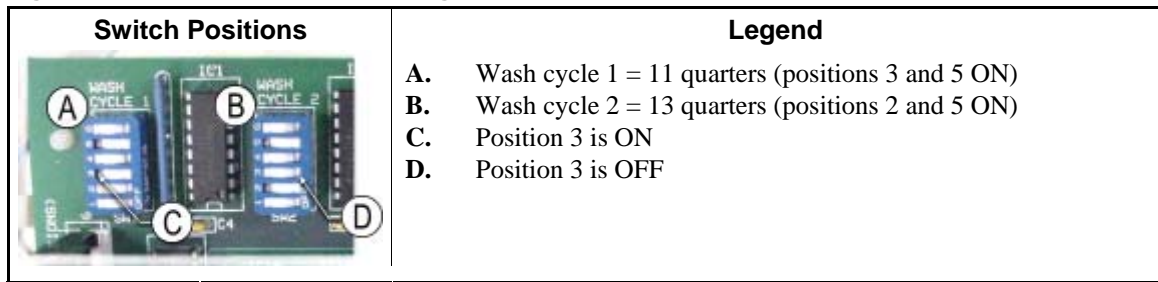

Table 5: DIP Switch Settings for Coin Count Offset

Offset	SW3-6	SW4-6	SW5-6	SW6-6
0	1	1	1	1
4	0	1	1	1
8	1	0	1	1
12	0	0	1	1
16	1	1	0	1
20	0	1	0	1
24	1	0	0	1
28	0	0	0	1
32	1	1	1	0
36	0	1	1	0
40	1	0	1	0
44	0	0	1	0
48	1	1	0	0
52	0	1	0	0
56	1	0	0	0
60	0	0	0	0
Note:	0 = Switch is OFF. 1 = Switch is ON.			

Table 6: DIP Switch Settings for Coin Counts

Counts	Switch					Counts	Switch					Counts	Switch					Counts	Switch				
	1	2	3	4	5		Counts	1	2	3	4		5	Counts	1	2	3		4	5	Counts	1	2
0	1	1	1	1	1	8	1	1	1	0	1	16	1	1	1	1	0	24	1	1	1	0	0
1	0	1	1	1	1	9	0	1	1	0	1	17	0	1	1	1	0	25	0	1	1	0	0
2	1	0	1	1	1	10	1	0	1	0	1	18	1	0	1	1	0	26	1	0	1	0	0
3	0	0	1	1	1	11	0	0	1	0	1	19	0	0	1	1	0	27	0	0	1	0	0
4	1	1	0	1	1	12	1	1	0	0	1	20	1	1	0	1	0	28	1	1	0	0	0
5	0	1	0	1	1	13	0	1	0	0	1	21	0	1	0	1	0	29	0	1	0	0	0
6	1	0	0	1	1	14	1	0	0	0	1	22	1	0	0	1	0	30	1	0	0	0	0
7	0	0	0	1	1	15	0	0	0	0	1	23	0	0	0	1	0	31	0	0	0	0	0
Note:	0 = Switch is OFF. 1 = Switch is ON.																						

Chapter 3

Operating

BICEXO01 (Published) Book specs- Dates: 20120411 / 20120411 / 20120411 Lang: ENG01 Applic: CEX

3.1. Control Panel

All operator and attendant functions of the Milnor® C_E electronic coin washer-extractor controller are accessible from the front control panel. The function of the various controls vary according to the position of the *Attendant* switch, as described in this document.

Figure 12: C_E Control Panel

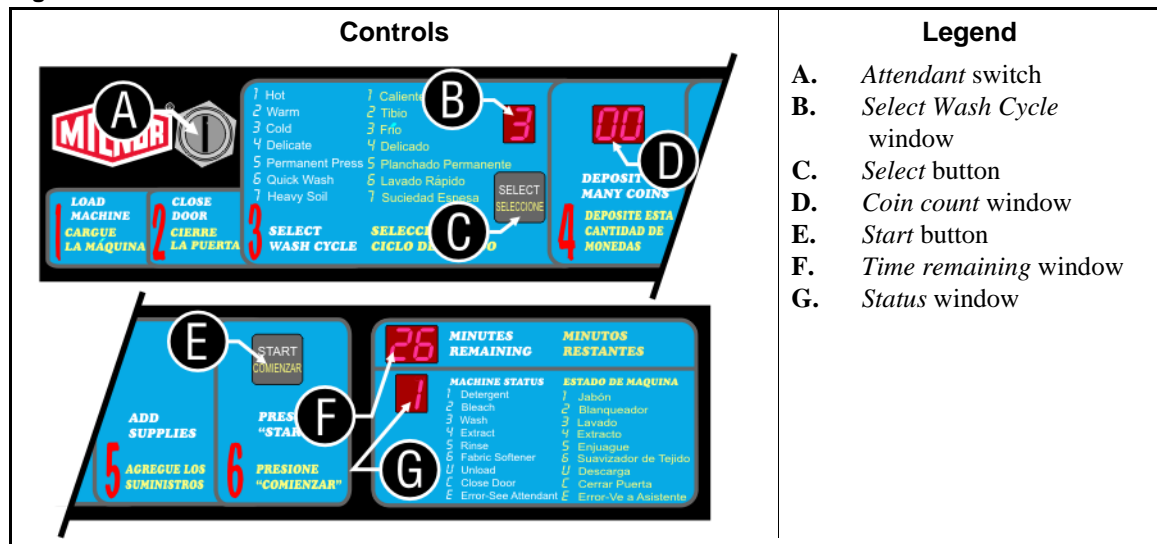

3.1.1. Control Functions During Normal Operation

Normal operation is the state of the machine when the machine control circuit is energized and the *Attendant* switch is in the vertical position (as shown in Figure 12). The machine may be either idle (waiting to run a wash cycle) or running. If the machine is idle, the display shows the time and required number of quarters for the selected wash cycle, as well as whether the door is open or closed.

- A. *Attendant* switch—must be kept in the normal (vertical) position with the key removed unless the attendant or a qualified technician is present and operating the machine. Cycle this switch to the horizontal position and back to the vertical position to clear controller errors, or turn this switch to the horizontal position (key cannot be removed) to access the control functions defined in Section 3.1.2 “Control Functions in *Attendant* Mode”.
- B. *Select Wash Cycle* window—if the door is closed, displays the wash cycle that will run when the correct number of quarters or dollar coins are inserted and the *Start* button is pressed.

- C. *Select* button—scrolls through the seven available wash cycles listed on the machine control panel. The current selected wash cycle is displayed in the *Select Wash Cycle* window. This button is ignored if the door is open.
- D. *Coin count* window—displays the number of quarters required to start the selected wash cycle if the door is closed. The quarters required value counts down toward 0 as each quarter is accepted, and decrements by four quarters when a dollar coin is accepted. When no more quarters are required, press the *Start* button to begin the selected wash cycle.

Note 4: The dual-slot coin acceptor for quarters and dollar coins is available on machines manufactured after July 2004.

- E. *Start* button—begins the wash cycle displayed in the *Select Wash Cycle* window after the required number of quarters are accepted. This button is ignored if the door is open.
- F. *Minutes Remaining* window—displays the number of whole minutes remaining in the selected wash cycle if the door is closed. If the *Select Wash Cycle* button is pressed before the *Start* button, the number in this display changes to reflect the duration of each wash cycle.
- G. *Machine Status* window—displays the current step or status of the selected wash cycle when the machine door is closed. If the machine door is open, this window displays “C” to prompt the customer to close the door. The decimal in the lower right corner of this window flashes any time a safety delay timer is counting, including power-up and coast times.

3.1.2. Control Functions in *Attendant* Mode

Attendant mode is the state of the machine when the machine control circuit is energized and the *Attendant* switch is in the horizontal position. The machine may be idle or running. If the machine is idle, the status of the door determines the options available and the appearance of the display.

- A. *Attendant* switch—must be kept in the normal (vertical) position and the key removed unless the attendant or a qualified technician is present and operating the machine. In the *Attendant* (horizontal) position, this switch allows viewing the software date code, status of microcontroller inputs, and actuation of microcontroller outputs for testing (see [Section 4.2. “Controller Inputs and Outputs”](#)). Cycle this switch to the horizontal position and back to the vertical position to clear controller errors (see [Section 4.1. “Error Codes”](#)) and to start the machine without requiring coins, or turn this switch to the vertical position and remove the key for normal operation ([Section 3.3. “Using the Machine”](#)).
- B. *Select Wash Cycle* window—displays various information according to the test or operation in progress:
 - 1. If the door is closed and the *Attendant* key is turned to the horizontal position, this window displays the formula that will execute when the *Start* button is pressed.
 - 2. This window displays the first digit in the software date code.
 - 3. During the display test, this digit and all others on the display count through all the numbers consecutively in reverse order.
 - 4. This window is not illuminated when viewing the status of the inputs or when outputs are being tested.
- C. *Select* button—cycles through the available functions available in *Attendant* mode:
 - 1. run formula without coins
 - 2. display software date code
 - 3. test display segments
 - 4. view input status
 - 5. test outputs and execute functional tests

If the door is open, press this button four times to clear the wash cycle accumulator (see [Section 3.3.3 “Viewing and Clearing the Accumulator”](#)).

- D. *Coin count* window—displays various information according to the test or operation in progress:
1. If the door is closed when the *Attendant* switch is turned to the horizontal position, this window displays “**St**” to indicate that pressing the *Start* button will start the wash cycle that was selected when *Attendant* mode was accessed.
 2. When viewing the software date code, the two digits in this window show the second and third digits of the date code.
 3. This display duplicates the scrolling numbers in all other displays while the display test is active.
 4. This display is not illuminated when the controller is set to display input status.
 5. When the controller is set to allow manual operation of outputs, “**00**” **flashes** in this window unless a safety delay timer is counting down, in which case this display is not illuminated.
- E. *Start* button—starts the formula that was previously selected after the *Attendant* switch is turned to the horizontal position. This button also performs other functions if the door is closed and the *Select* button is pressed before the *Start* button:
1. When viewing the status of the inputs, the upper right segment of the ones digit in the *Minutes Remaining* window represents the *Start* button. This segment illuminates when the button is pressed.
 2. During the test of outputs and the functional tests, the *Start* button toggles the selected output or functional test on and off each time it's pressed.
- F. *Minutes Remaining* window—displays various information according to the test or operation in progress:
1. When the software date code is displayed, this window contains the last two digits of the code.
 2. This display duplicates the scrolling numbers in all other displays while the display test is active.
 3. When the input test is active, the left (tens) digit of this window represents the micro-controller inputs to the processor board. The right (ones) digit of this window represents the inputs to the display board. See [Section 4.2. “Controller Inputs and Outputs”](#) for more details about the input test.
 4. When the output test is active, this window displays the output or functional test currently selected.
- G. *Machine Status* window—displays the current step or status of the selected wash cycle that will run if the *Start* button is pressed before the *Select* button. This window also displays other information according to the current test or operation:
1. This window is not illuminated when the software date code is displayed or when the inputs test is selected.
 2. During the display test, this window duplicates the characters in all other display windows.
 3. When the output test is selected, this window displays whether the selected output or functional test is on (represented by a “1”) or off (represented by a “0”). When a safety delay timer is counting down—as occurs when the extract speed output is turned off—the decimal in the lower right corner of this display flashes.

3.2. Determining Load Size

Putting **too much** linen into a properly designed laundry washer-extractor will not **overload** the machine to its mechanical or electrical detriment if these guidelines are followed:

1. The goods consist of typical cotton and/or synthetic fabrics normally encountered in commercial laundering operations.
2. The load is not so bulky as to prevent a reasonably balanced distribution prior to the onset of extraction.
3. The extract speed has not been increased above the designed maximum.
4. The total number of intermediate and final extractions do not exceed the designed maximum for the extract motor.

Thus, the *maximum soiled linen capacity* for any properly designed washer-extractor is essentially limited by the amount of soiled goods that can actually be placed in the cylinder.

The maximum weight of soiled goods that a washer-extractor cylinder will accept depends on the following factors:

- the internal volume of the cylinder (the space into which the goods can be placed), and
- the density (weight and bulkiness) of the specific goods

For example, many polyester-cotton fabrics have relatively low weights for their bulk so one should rarely expect to be able to put in a published maximum capacity load of such fabrics. In fact, published maximum capacities of machines based on the now generally accepted industry standards will usually be achieved only with the highest density, closely woven fabrics and a reasonable soil content.

The best load size depends on the size of the machine—plus the type of goods, soil content, and wash quality desired. Since the latter factors vary considerably, prior experience and/or experimentation generally yield the best results. Use these guidelines:

1. Overloading a washer-extractor will not increase production because longer wash formulas and more rewash will be required.
2. Avoid underloads because the inevitable greater extraction imbalance will cause more extract re-cycles and may stress the machine unnecessarily.

— End of BIWUUO01 —

3.3. Using the Machine

Milnor[®] electronic coin washer-extractor controllers allow wash cycles to be started in two ways:

- [Section 3.3.1](#) describes how a paying customer operates the machine, including loading the machine, selecting the desired wash cycle, and starting the machine by inserting coins (quarters or dollar coins) and pressing the *Start* button.
- [Section 3.3.2](#) describes how laundry personnel can operate the machine without using coins by setting the *Attendant* switch to the *Attendant* (horizontal) position.

[Section 3.3.4](#) includes a brief overview of the error recovery process. Refer to [Section 4.1](#). “[Error Codes](#)” for more details on error recovery. [Supplement 3 “Recycle Sequence to Reduce Vibration During Extract”](#) details the sequence of actions automatically commanded by the control system if the vibration safety switch trips because of excessive vibration during an extract step.

3.3.1. Normal Operation (Coins Required)

1. Open door and load machine.

Load the machine at or near its rated capacity, as described in [Section 3.2. “Determining Load Size”](#). Processing small loads in any washer-extractor increases the possibility of excessive vibration.

2. Close door.

Securely close the loading door. Safety features on this machine are designed to notify the customer if the door is open. If this machine is in proper working order with all safety devices in place, it will not operate unless the door is completely closed. To prevent the customer from accidentally opening the door while the machine is operating, the door latch is locked in the closed position 60 seconds after the wash cycle starts.

Notice 27: The door latch lock delay timer locks the door latch 60 seconds after the wash cycle starts. This timer resets to the full 60 seconds each time the door is opened and subsequently closed.

Display or Action



Explanation

3. Select desired wash cycle.

Press the *Select* button repeatedly to scroll through the seven available wash cycles shown on the machine control panel. Each time the customer presses the *Select* button, the number in the *Select Wash Cycle* window increases by one count and the values in the *Minutes Remaining* and *coin count* windows change to reflect the duration of the selected cycle and the number of coins required.

4. Deposit the required amount of money.

For any wash cycle displayed in the *Select Wash Cycle* window, the *coin count* window displays the number of quarters required to run the cycle. The value in the *coin count* window decreases by one unit for each quarter, or by four units for each dollar accepted and counted by the machine controller. The coin count is satisfied when the value in the *coin count* window is “00”. Coins can not be deposited in the coin slot until the door is closed.

5. Add supplies.

Add the desired amount of detergent through the supply chute on the upper part of the machine cylinder, then close the supply chute door. When the *Machine Status* window displays “2” or when the machine has filled to level with water, add the proper amount of bleach. Similarly, add fabric softener when the *Machine Status* window displays “6” (at the beginning of the last rinse step). Liquid chemicals will be injected automatically at the correct times in facilities equipped with liquid chemical supply systems. For machines equipped with an optional three-compartment supply injector, refer to [Supplement 2 “The Three-Compartment Supply Injector \(Optional\)”](#).

Supplement 2

The Three-Compartment Supply Injector (Optional)

Some C_E model washer-extractors are equipped with an optional three-compartment supply injector designed to flush pre-measured quantities of powdered chemicals (usually detergent, bleach, and softener) into the machine at the appropriate times.

Operation—This assembly consists primarily of a stainless steel box divided internally into three separate compartments and a supply chute which is open to the contents of the machine cylinder. When the wash cycle requires a chemical, the controller actuates an output (see Section 4.2. “Controller Inputs and Outputs”) to open one of three water valves in the injector. Water sprays into the compartment, dilutes the chemical, and overflows the compartment into the machine cylinder.

Supply chute—directs chemicals flushed from the three compartments into the cylinder. Because the supply chute opens directly to the cylinder, it may be used to **manually** add chemicals at any time.

Detergent compartment—the leftmost compartment, nearest the top of the cylinder. The contents of this compartment are flushed into the cylinder while the machine fills for a detergent bath step, when the *Machine Status* window displays “1.” This compartment is also flushed when any other pocket is flushed.

Bleach compartment—the center compartment. This compartment is flushed while the machine fills for a bleach bath step, when the *Machine Status* window displays “2.” The bleach compartment is also flushed when the softener compartment is flushed.

Softener compartment—the rightmost compartment, farthest from the top of the cylinder. This compartment is flushed while the machine fills for the final rinse of a wash cycle, when the *Machine Status* window displays “6.”

Display or Action



Explanation

6. **Press *Start*.**

Press the *Start* button to begin the wash cycle. When the wash cycle terminates, open the door and unload the machine.

Notice 28: A different wash cycle can be selected any time before the *Start* button is pressed by pressing the *Select* button. If the wash cycle is changed to one requiring more money, the *coin count* window will prompt for the desired number of quarters, and the controller will prevent starting the machine. If the wash cycle is changed to one requiring fewer coins, the *coin count* window displays “00” and the machine can be started.

During operation, the right decimal in the *Minutes Remaining* window flashes when the timer is counting. The decimal is dark when the timer is not counting, as while the machine is filling with water for the first time in any bath step.

The *Machine Status* window displays a flashing decimal during the safety delay period before the controller unlocks the door latch. The decimal also flashes any time the basket is coasting, as after an intermediate extract step.

When the wash cycle is finished, the *Machine Status* window flashes “U” to indicate that the safety delay timer has expired and the door latch is unlocked. The decimal point on the right side of the *Minutes Remaining* window flashes to indicate that the door has not been opened since the wash cycle ended. Open the door and remove the goods.

When the customer opens the machine door after a wash cycle ends, the *Machine Status* window immediately flashes “C” to prompt the customer to close the door.

3.3.2. Attendant Operation (Attendant Key Required)

Two situations call for this method of operation: recurring attendant operation as when customers drop off laundry for later pickup, and restarting a terminated wash cycle without requiring additional coins.

1. Open door and load machine.

Load the machine at or near its rated capacity, as described in [Section 3.2. “Determining Load Size”](#). Processing small loads in any washer-extractor increases the possibility of excessive vibration.

2. Close door.

Securely close the loading door. Safety features on this machine are designed to notify the user if the door is open. If this machine is in proper working order with all safety devices in place, it will not operate unless the door is completely closed. To prevent the user from accidentally opening the door while the machine is operating, the door latch is locked in the closed position 60 seconds after the wash cycle starts for the first time, or when the wash cycle resumes after the door is opened and subsequently closed.

3. Select desired wash cycle.

Press the *Select* button to scroll through the available wash cycles shown on the machine control panel. Each time the attendant presses the *Select* button, the number in the *Select Wash Cycle* window of the control panel increases and the value in the *Minutes Remaining* window changes to display the duration of the selected cycle.

Notice 29: Always select the desired wash cycle before turning the *Attendant* switch to the horizontal position. When the *Attendant* switch is in the horizontal position, the *Select* button scrolls from the selected program to the various testing modes described in [Section 4.2. “Controller Inputs and Outputs”](#). To exit the testing modes, turn the *Attendant* switch to the vertical position.

4. Set the Attendant switch to the Attendant (horizontal) position.

Insert the attendant key and turn the switch clockwise one quarter turn to access *Attendant* mode. The *coin count* window displays “St” to prompt the attendant to press the *Start* button.

5. Add supplies.

Add the desired amount of detergent through the supply chute on the upper part of the machine cylinder, then close the supply chute door. When the *Machine Status* window displays “2” or when the machine has filled to level with water, add the proper amount of bleach. Similarly, add fabric softener when the *Machine Status* window displays “6” (at the beginning of the last rinse step). Liquid chemicals will be injected automatically in facilities equipped with liquid chemical supply systems. For machines equipped with an optional three-compartment supply injector, refer to [Supplement 2 “The Three-Compartment Supply Injector \(Optional\)”](#).

Add the desired amount of detergent, bleach, and softener to the appropriate supply dispenser pockets on top of the machine. The chemicals will be automatically flushed into the machine cylinder at the appropriate times in the wash cycle.

During operation, the right decimal in the *Minutes Remaining* window flashes when the timer is counting. The decimal is dark when the timer is not counting, as while the machine is filling with water for the first time in any bath step.

6. Press Start.

Press the *Start* button to begin the wash cycle.

7. **Set the *Attendant* switch to the normal operating position.** Remove the key.
8. **Unload the machine when the wash cycle ends.**

When the wash cycle is finished, the *Machine Status* window displays “U” to indicate that the safety delay timer has expired and the door latch is unlocked. The decimal point on the right side of the *Minutes Remaining* window flashes to indicate that the door has not been opened since the wash cycle ended. Open the door and remove the goods.

When the attendant opens the machine door after a wash cycle ends, the display immediately goes dark except for the *Machine Status* window. The *Machine Status* window flashes “C” to prompt the attendant to close the door.

3.3.3. Viewing and Clearing the Accumulator

The controller maintains a wash cycle counter—called an accumulator—which increments when any wash cycle is started. The procedure for viewing the accumulator is described in [Section 3.3.3.1](#). The accumulator resets when power is removed from the machine, or it can be manually reset by following the steps in [Section 3.3.3.2](#).

The value stored in the accumulator increases by one count each time the *Start* button is pressed to start a wash cycle.

- 3.3.3.1. **Viewing the Accumulator**—The accumulator contains a value from 000 to 999, representing the total number of wash cycles performed since the last time the machine was powered off or the accumulator was cleared. To view the contents of the accumulator, open the door and turn the *Attendant* switch to the *Attendant* (horizontal) position.

Figure 13: Wash Cycle Accumulator

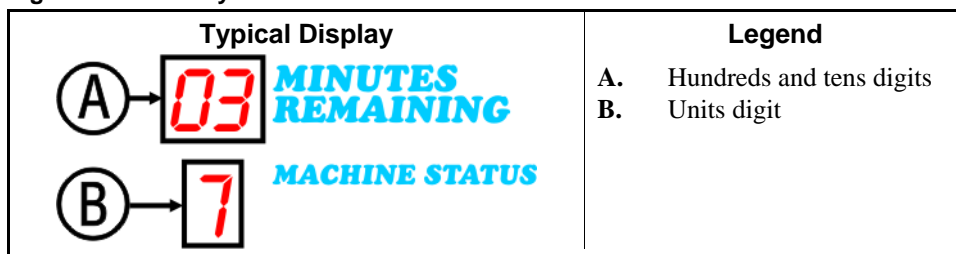

As shown in [Figure 13](#), the *Minutes Remaining* window displays the first two digits of the accumulator value, while the *Machine Status* window displays the third digit. In the example shown here, the machine has completed 37 wash cycles since the accumulator was reset. The *Select Wash Cycle* and *coin count* windows display normal operating values not included in the accumulator count.

- 3.3.3.2. **Clearing the Accumulator**—Clear the accumulators by turning off power to the machine at the wall disconnect, or by pressing the *Select* button three times while any accumulator is visible. The value for the accumulator immediately resets to “000.”

3.3.4. Error Recovery

An error condition occurs if the machine controller detects a condition which might be unsafe or cause machine damage. See [Section 4.1. “Error Codes”](#) for a detailed description of possible errors and corrective actions.

Some errors, such as the error that occurs if the machine does not fill to level within the allotted time, are caused by transient conditions and require no immediate corrective actions other than

clearing the error. When an error of this type occurs, use the following procedure to return the machine to service:

1. If possible, resolve the cause of the error.
2. Turn the *Attendant* switch to the horizontal position.
3. Return the *Attendant* switch to the vertical position and remove the key.

Tip: To restart the selected wash cycle at the beginning, press the *Start* button while the switch is in the horizontal position, then turn the switch to the vertical position and remove the key.

Supplement 3

Recycle Sequence to Reduce Vibration During Extract

If this machine—or any washer-extractor—is severely underloaded, the possibility exists for excessive vibration when the machine tries to extract the goods. The vibration safety switch within the machine cabinet detects this excessive vibration and provides an input to the micro-controller if the controller is commanding an extract step. The software in the micro-controller instructs the machine to follow one of the following two procedures, depending on the type of extract in progress when the vibration switch tripped.

- If the vibration switch trips during an **intermediate** extract (an extract between two bath steps), the basket coasts for the remaining extract time then resumes normal operation at the beginning of the next bath step.
- If the vibration switch trips during the final extract of a wash cycle, the machine goes through an extract recycle sequence to try to reduce the degree of imbalance and complete the wash cycle. The recycle sequence described below repeats until the machine successfully completes the wash cycle or three recycle attempts have failed to complete the extract step.
 1. The wash cycle timer stops. The *Select Wash Cycle* window and the *coin count* window maintain their current contents. The *Minutes Remaining* window retains the time remaining in the wash cycle, but the decimal point at the right side of this window—which usually flashes to indicate that the cycle timer is running—does not flash.
 2. The basket coasts for 100 seconds. During this time, the *Machine Status* window flashes 4 (extract).
 3. The basket turns counter-clockwise at wash speed for 15 seconds.
 4. The basket dwells for 3 seconds with no motor power.
 5. The basket turns clockwise at wash speed for 15 seconds.
 6. The basket turns clockwise at distribution speed for 25 seconds.
 7. The wash cycle timer starts and the basket accelerates immediately to extract speed after the 25-second distribution period expires. The rightmost decimal in the *Minutes Remaining* window resumes flashing to indicate that the wash cycle timer is running.

— End of BICEX002 —

BICEXP01 (Published) Book specs- Dates: 20120411 / 20120411 / 20120411 Lang: ENG01 Applic: CEX

3.4. Standard Wash Cycles

This document describes the seven wash cycles provided in your Milnor® C_E coin washer-extractor controller. Refer to [Section 3.3. “Using the Machine”](#) for instructions on starting a wash cycle with coins or the *Attendant* switch.

Chapter 3. Operating

Note 5: Because the incoming water pressure and other factors influence the time required for the machine to fill, the run times stated below do not include machine fill times. For all flush, bath, and rinse steps, the timer starts after level is achieved.

Note 6: The display shows *01 Minutes Remaining* until the safety delay period expires and the controller unlocks the door latch.

The standard wash cycles shown in [Table 7](#) are available in all Milnor C_E model machines. The GreenTurn™ wash cycles shown in [Table 8](#) are available in machines running software WUC4E1A/20010 and later. See [Section 2.1. “Selecting the Formula Set and Setting the Coin Counts”](#) for instructions on how to configure the machine to use either set of wash cycles.

Table 7: Standard Wash Cycles

	Hot	Warm	Cold	Delicate	Permanent Press	Quick Wash	Heavy Soil
Flush							2:00 Cold
Drain							1:15
Detergent	5:00 Hot	5:00 Split	5:00 Cold	4:00 Split	5:00 Split	3:00 Split	7:00 Split
Drain	1:15	1:15	1:15	1:15	1:15	1:15	1:15
Bleach	4:00 Hot	4:00 Split					4:00 Hot
Rinse			2:00 Cold	2:00 Cold	2:00 Split	2:00 Cold	
Drain	1:15	1:15	1:15	1:15	1:15	1:15	1:15
Extract			0:45	0:45	0:45	0:45	
Rinse	2:00 Split	2:00 Cold	2:00 Cold		2:00 Cold		2:00 Split
Drain	1:15	1:15	1:15		1:15		1:15
Extract	0:45	0:45					0:45
Softener	3:45 Cold	3:45 Cold	3:45 Cold	3:45 Cold	3:45 Cold	3:45 Cold	3:45 Cold
Drain	1:15	1:15	1:15	1:15	1:15	1:15	1:15
Extract	6:00	6:00	6:00	5:00	6:00	5:00	6:00
Total (includes coasts)	29:00	29:00	26:00	21:45	26:00	20:45	36:15
Displayed Time	29	29	26	21	26	20	36

Table 8: GreenTurn™ Wash Cycles (available in WUMCR1A/200013 and later, and WUC4E1A/200010 and later)

	Hot	Warm	Cold	Delicate	Permanent Press	Quick Wash	Heavy Soil
Flush							2:00 Cold
Drain							1:15
Detergent	4:00 Hot	4:00 Split	4:00 Cold	3:00 Split	4:00 Split	2:00 Split	5:00 Split
Drain	1:15	1:15	1:15	1:15	1:15	1:15	1:15
Bleach	3:00 Hot	3:00 Split					3:00 Hot
Rinse			2:00 Cold	2:00 Cold	2:00 Split	2:00 Cold	
Drain	1:15	1:15	1:15	1:15	1:15	1:15	1:15
Extract			0:45	0:45	0:45	0:45	
Extract	0:45	0:45					0:45
Softener	3:00 Cold	3:00 Cold	3:00 Cold	3:00 Cold	3:00 Cold	2:00 Cold	3:00 Cold
Drain	1:15	1:15	1:15	1:15	1:15	1:15	1:15
Extract	6:00	6:00	6:00	5:00	6:00	5:00	6:00
Total (includes coasts)	23:00	23:00	21:00	20:00	21:00	18:00	28:30
Displayed Time	23	23	21	20	21	18	29

Note 7: Drain and coast times listed in [Table 9](#) are subject to change without notice. Coast time occurs after each extract step.

Table 9: Standard Coast and Delay Times (in seconds)

Software Version and Date Code	Power-up Delay	Door Lock Delay	Intermediate Extract Coast	Final Extract Coast
WUC4E1A/20001 - WUC4E1A/20006	100	60	25	100

— End of BICEXP01 —

Chapter 4

Testing and Troubleshooting

BICEXT01 (Published) Book specs- Dates: 20120411 / 20120411 / 20120411 Lang: ENG01 Applic: CEX

4.1. Error Codes

If the machine control detects an error, the *Minutes Remaining* window flashes an error code corresponding to the condition, and the *Machine Status* window may flash *E*, *H*, or a number to notify the customer that an error occurred, or *U* to signal the customer to unload the machine. Figure 14 illustrates the two display windows important in troubleshooting error codes. The displays in Section 4.1.2 “Explanations of Error Codes” show only the contents of the *Minutes Remaining* window.

Tip: All error codes result from micro-controller inputs being present or absent under certain conditions. Refer to Section 4.2. “Controller Inputs and Outputs” and the appropriate schematics and service manuals for this machine when diagnosing errors.

Figure 14: Error Code Display

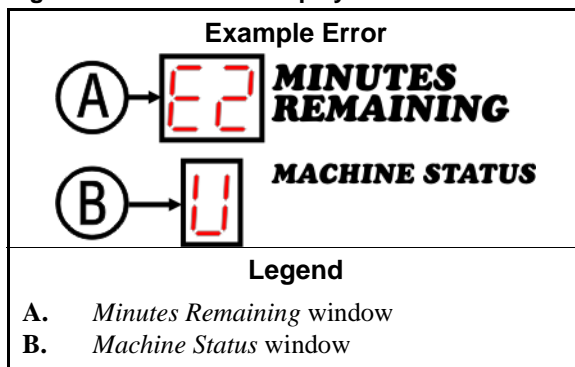

4.1.1. How to Clear Error Conditions

Some error conditions, such as *E4 (Too Long to Fill)* clear automatically when the conditions which caused the error are rectified. These errors require no intervention to return the machine to normal operation.

Other errors require that the attendant clear the error before the machine can resume normal operation. To clear these errors, the authorized personnel must turn the *Attendant* keyswitch from the normal (vertical) position shown in Figure 15 to the *Attendant* (horizontal) position shown in Figure 16, then back to the normal position. **The attendant should never leave the key in the switch or any place accessible to customers.**

Figure 15: Normal Position of Attendant Switch

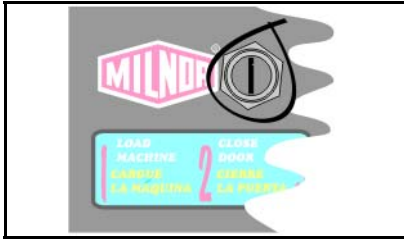

Figure 16: Attendant Position of Attendant Switch

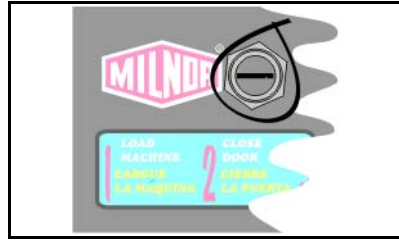

Table 10: Quick Reference for Error Codes

Error Code	Error Name	Attendant Required?
E0	Door not closed error	No
E1	Door latch lock error	Yes
E2	Coin acceptor error	Yes
E3	Level switch error	Yes
E4	Too long to fill	No
E5	Too long to drain	Yes
E6	Inverter fault	Yes
E7	Brake error	Yes
E9 H	Door latch handle error	No

4.1.2. Explanations of Error Codes

Display or Action

Explanation

E0

Door Not Closed Error: The door closed input was lost after the controller commanded the door latch locked. The controller terminates the formula. The user can open the door after 25 seconds if the error occurred during a wash or drain step, or after 100 seconds if the error occurred during an extract step.

E1

Door Latch Lock Error: The door latch lock safety circuit is not responding properly. This error usually indicates that three conditions exist simultaneously:

- The door is closed.
- The controller enabled the specific output which locks the door latch to prevent opening the door.
- After 5 seconds, the controller sees the input which indicates that the door latch is **not** locked.

Rarely, the error can occur when the machine is idle or in the first 60 seconds of running a wash formula (while the door is unlocked), and the input that says “door unlocked” is not present.

This error condition can occur any time the machine has power after the power-up delay expires. The attendant must clear this error (see [Section 4.1.1](#)), then the formula is terminated.

Display or Action Explanation

Note 8: The door latch lock is normally activated 60 seconds after the customer or attendant starts a wash cycle. The timer resets to 60 seconds each time the door is opened and subsequently closed. The door latch remains locked for 100 seconds after the wash cycle terminates normally, to allow the basket to coast to a complete stop.

E 2

Coin Acceptor Error: The coin switch is not responding properly. Specifically, the controller expects the coin acceptor device to represent each coin with an input pulse of less than 200ms, and for each input pulse to be separated from the previous pulse by at least 200ms. This error requires the attention of the attendant.

Note 9: For machines equipped with a dual-coin acceptor for both quarters and dollar coins, the pulse duration and separation must be maintained without regard to which slot is used. For example, a coin dropped in the dollar slot must follow at least 200ms behind a coin dropped in the quarter slot, or vice versa.

If the pulse duration differs from the duration specified in the controller software or if the pulses are separated by less than 200ms, the attendant must clear the error (see [Section 4.1.1](#)).

This error, if it occurs immediately after the power-up delay expires, may indicate that incompatible software is installed. MCR_ models require machine software with part number WUMCR1A/__. Software intended for Milnor C_E models (part number WUC4E1A/__) will not operate an MCR_ machine, nor vice versa. If the machine has the wrong software installed, the controller will not allow the user to enter *manual* mode or start a formula.

E 3

Level Switch Error: The level switch input is made when the controller expects it to be absent before the wash cycle begins. The attendant must clear this error (see [Section 4.1.1](#)), which is usually caused by a malfunctioning level switch.

E 4

Too Long to Fill: The level switch indicates that the machine did not achieve level within the 10 minutes allowed after the beginning of a bath step. When this error occurs, the timer stops until level is achieved, then restarts. The error clears without intervention when level is achieved.

If level is not achieved after 20 minutes, the controller terminates the wash cycle and advances to the door unlock delay (25 seconds). The delay allows time for the basket to stop and for any water to drain before the door can be opened.

Tip:

To prevent recurrence of this error, verify that water inlet pressure is within the range specified in the service manual and that the debris screens at the water inlet valves are clean.

E 5

Too Long to Drain: When the machine starts draining, a 40 second timer is set. During this drain time the decimal blinks to indicate that the cycle timer is running. If level is still made after the 40 seconds expires, the machine goes into *drain halt* mode. In *drain halt* mode the basket runs at drain speed with the drain open, but the decimal stops blinking and the timer stops counting. The machine continues in this state for 1800 seconds or until level is lost. If level is lost the machine continues to the next step with no error. If the 1800-

Display or Action	Explanation
E6	<p>second timer expires, the controller terminates the cycle and signals an error. The attendant may clear this error (see Section 4.1.1).</p> <p>Inverter Fault: The inverter signalled an internal fault while the machine was running. Any time the basket is being powered by the motor, the controller monitors an input from the inverter. This error occurs if the controller does not see the input at all times when the motor should be turning the basket.</p> <p>The controller terminates the wash cycle and immediately turns off all machine outputs except <i>Inverter enable</i> and <i>Door lock</i> (see Table 12 “Output Signals”). The attendant must clear this error as described in Section 4.1.1. After a safety delay of 100 seconds, the door latch unlocks, eliminating all power to the inverter.</p>
Tip:	<p>The inverter retains a list of the latest inverter fault codes encountered even when power is not present. Refer to the documentation for the inverter installed in your machine to view these fault codes and diagnose the underlying conditions.</p>
E7	<p>Brake Error: The controller detected an error with the brake device. This error occurs if the door is open and the brake is not engaged, or if the brake is engaged when the door is closed. The inputs signalling the micro-controller that the door is closed and that the brake is engaged must always be in opposite states.</p> <p>The controller prevents all machine operation for 100 seconds, after which the attendant must clear the error as described in Section 4.1.1. Normal operation can resume after the attendant clears the error.</p>
E7 7	<p>Vibration Switch Input Error: The vibration switch is checked at power-up and during extract. This error at power-up prevents machine operation and usually occurs when the service technician responsible for installing the machine doesn't untie the vibration switch actuator. The machine recycles if this error occurs during an extract step.</p>

See [Supplement 3](#) for a more detailed description of the extract recycle sequence.

Chart 1: Test to Prove Door is Properly Latched

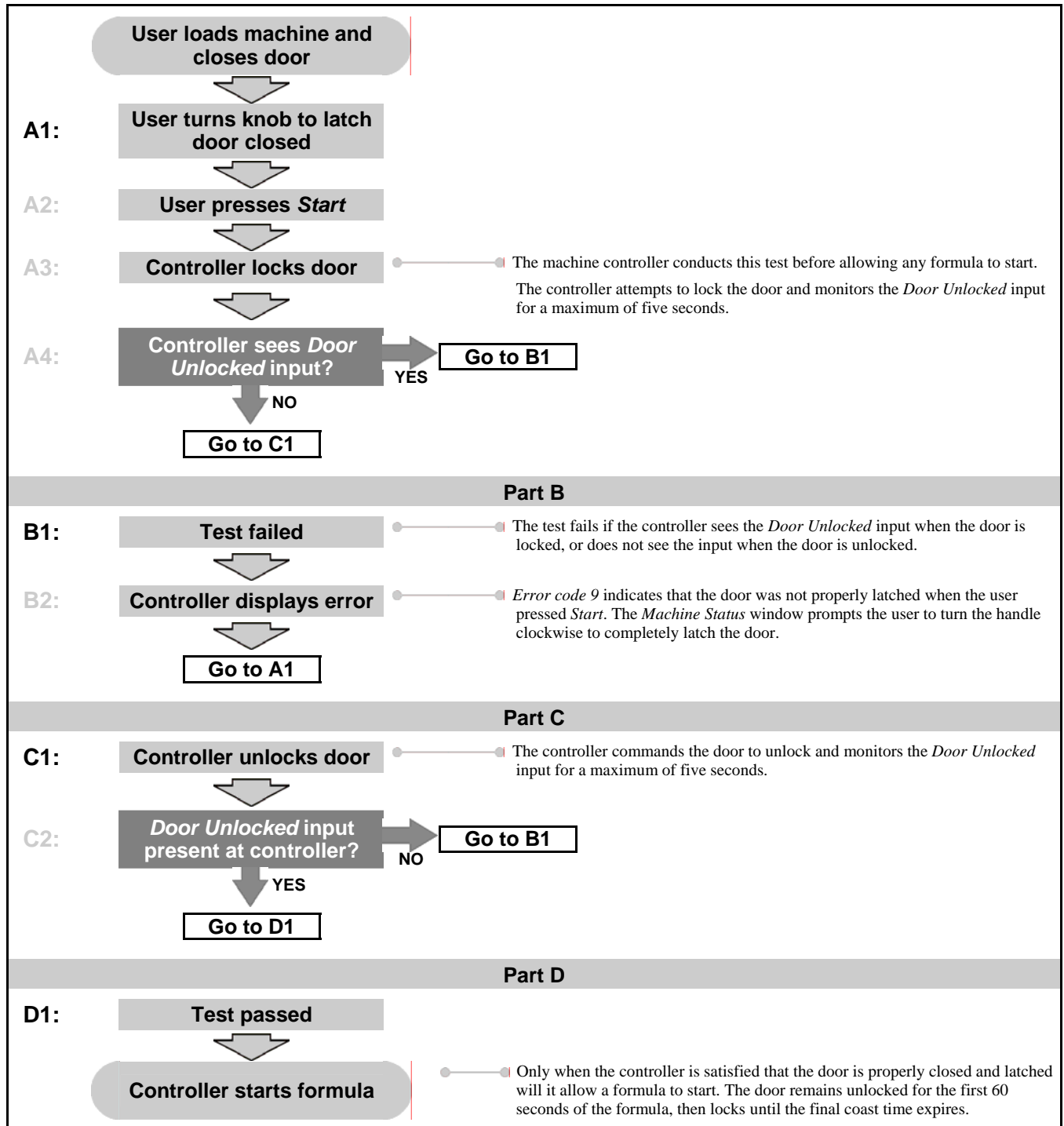

— End of BICEXT01 —

4.2. Controller Inputs and Outputs

Microprocessor **inputs** are received at the processor board from other machine components. Inputs that are **present** at the processor board usually indicate that a device is actuated. For

example, *Level made* input originates from the water level switch and tells the processor board the machine has filled with water to the desired level. With the *Attendant* switch enabled, the status of each input can be determined by viewing the display as described in [Section 4.2.2 “Viewing Inputs”](#).

Outputs are signals from the micro-controller which cause machine components to operate (e.g., water valves open, drain valve closes). With the *Attendant* switch enabled, the front panel controls allow a qualified technician to operate certain functions individually and to simulate machine operation for testing. These procedures are detailed in [Section 4.2.3 “Actuating Outputs and Functional Tests”](#).

4.2.1. Resuming Normal Operation

To resume normal operation from the *attended run* mode or when displaying the software date code, the display test, or the input status test, turn the *Attendant* switch to the normal (vertical) position. The normal run display appears immediately. The wash cycle that was selected before the *Attendant* switch was turned is restored to the display.

From the *output and functional test* mode, turn the *Attendant* switch to the normal (vertical) position. If no outputs are enabled and the safety delay timer is not counting when the *Attendant* switch is returned to the normal mode, the normal run display appears immediately. The wash cycle that was selected before the *Attendant* switch was turned is restored to the display.

If the *Attendant* switch is turned to the normal (vertical) position while the basket is turning at drain or extract speed or if the safety delay timer is counting down, the status of the *Attendant* switch is checked after the safety delay timer expires.

4.2.2. Viewing Inputs

Use the procedure detailed below to view the status of all inputs to the micro-controller. Each input is mapped to a specific segment of the *Minutes Remaining* display, as shown in [Figure 17](#). [Table 11 “Input Signals for Milnor C_E Coin Models”](#) contains the names and functions of all inputs, as well as the connector and pin on the processor board that conveys the signal.

Figure 17: Viewing Inputs in *Attendant* Mode

Left Digit of <i>Minutes Remaining</i> Display	Right Digit of <i>Minutes Remaining</i> Display	Legend
		<ul style="list-style-type: none"> 0. Brake (MTA3-9) 1. Door unlocked (MTA3-2) 2. Quarter count (MTA3-3) 3. Inverter OK (MTA3-4) 4. Door closed (MTA3-5) 5. Dollar count (MTA3-6) 6. Level made (MTA3-7) 7. Vibration switch tripped (MTA3-8) 8. <i>Select</i> button 9. <i>Start</i> button 10. <i>Attendant</i> switch 11. -15. not used

Table 11: Input Signals for Milnor C_E Coin Models

Signal Name	Connector	Pin	Function
Brake	MTA3	9	brake is engaged
Door not locked		2	door latch is unlocked
Quarter count		3	quarter coin drop activated
Inverter OK		4	inverter reports normal operation
Door closed		5	door is closed
Dollar count		6	dollar coin drop activated
Level made		7	level is achieved
Vibration		8	vibration switch tripped
Attendant switch	MTA2	serial	control panel switch closed
Select button		serial	Select button pressed
Start button		serial	Start button pressed

The status of micro-controller inputs can only be viewed if the machine is idle (not running a formula) and the door is closed.

Display or Action

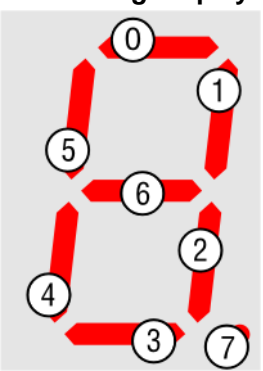
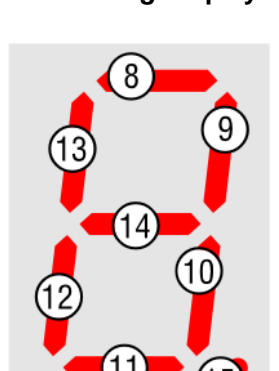
Explanation



With power present at the machine, insert the key in the *Attendant* switch and turn the switch from the vertical to the horizontal position.

Note 10: The key cannot be removed from the *Attendant* switch while the switch is in the *Attendant* (horizontal) position. Turn the switch to the *normal* (vertical) position to release the key.

Display or Action

Explanation



starts the formula that was selected before the *Attendant* switch was turned to the horizontal position.



displays the date code of the software in the machine. This keystroke also advances the controller beyond the point at which a formula can be started without inserting coins. If the intent was to start a formula without requiring coins, turn the *Attendant* switch to the vertical position and return it to the horizontal position, then immediately press the *Start* button.



The software date code for this example machine is 20001.



from the software date code display, displays the machine inputs status. For each input made, one segment of the *Minutes Remaining* window illuminates. Refer to [Figure 17](#) for which segment corresponds to each input.

Tip: Because the *Select* button advances the control from displaying inputs to testing outputs, it is not practical to view the status of the *Select* button input on the display. The *Select* button can be assumed to be working properly if the control advanced from displaying the software date code to the display inputs test.

4.2.3. Actuating Outputs and Functional Tests

Table 12: Output Signals

Output Name	Connector	Pins	Function	Test
Door lock	MTA5	9, 10	door locks	00
Drain speed		7, 8	inverter drives motor at drain speed; inverter enabled output also engaged	01
Drain closed		3, 4	drain closes	02
Hot water		1, 2	hot water valve opens	03
Cold water	MTA4	9, 10	cold water valve opens	04
Clockwise wash		7, 8	inverter drives motor clockwise at wash speed; inverter enabled output also engaged	05
Counter-clockwise wash		3, 4	inverter drives motor counter-clockwise at wash speed; inverter enabled output also engaged	06
Extract speed		1, 2	inverter drives motor at extract speed; inverter enabled output also engaged	07
Inverter enable (not used on MCR_ models)	MTA6	1, 2	inverter is enabled for operation	08
Chemical 1		3, 4	30-second signal for chemical 1 (detergent)	09
Chemical 2		7, 8	30-second signal for chemical 2 (bleach)	10
Chemical 3		9, 10	30-second signal for chemical 3 (finish)	11

Display or Action

Explanation



from the input status display begins the output test.

Tip: In the output test, the *coin count* window flashes 00 unless the controller is counting down a safety delay. During the delay period of up to 100 seconds, the *coin count* window is dark and the decimal point in the *Machine Status* window flashes to indicate that the controller is working. When the safety delay time expires, the *Coin Count* window again flashes 00.

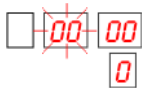

normal display immediately upon entering the output test. The *Minutes Remaining* window displays the number of the selected output or functional test, and the *Machine Status* window displays the status of the selected item.



in the *Machine Status* window indicates that the selected output or functional test is in the inactive state (off).



in the *Machine Status* window indicates that the selected output or functional test is active (on).



turns off the selected output or functional test if it is on, then advances to the next output.



toggles the on/off status of the selected output or functional test.

4.2.4. Functional Tests

In the output testing mode, the controller provides two functional tests. These tests are addressed in the same manner as the output tests, but also check the status of several inputs by simulating certain elements of a wash cycle. Functional test 12 (see [Section 4.2.4.1](#)) verifies the fill and bath operations, while functional test 13 (see [Section 4.2.4.2](#)) checks the function of the inverter through all basket speeds.

4.2.4.1. Functional Test 12—This test is useful for checking the water valves, drain valves, door lock, and wash speeds. The test executes as described below:

Display or Action

Explanation



from output test 11 (chemical 3), turns off output 11 and advances to functional test 12



initiates the test.

1. Door locks, drain closes, inverter enabled, hot and cold water valves open.
2. After four seconds of dwell time, the basket turns clockwise for 15 seconds.
3. The water valves close when level is achieved.
4. The basket dwells for four seconds, then turns counter-clockwise for 15 seconds. This cycle continues indefinitely.



terminates the test. The drain opens, the inverter is disabled, the water valves close, and the door unlocks.

or



terminates the test and advances the control to functional test 13.

4.2.4.2. Functional Test 13—This test checks the door lock, inverter speeds, and vibration switch. The test executes as described below:

Display or Action

Explanation



from functional test 12, turns off test 12 and advances to functional test 13.



initiates the test.

1. The door locks, the inverter is enabled, and the basket turns clockwise at wash speed for 25 seconds.
2. The basket accelerates to drain speed for 25 seconds.
3. The basket accelerates to extract speed and maintains this speed indefinitely.
4. If the vibration switch is momentarily tripped, the inverter is disabled and the safety delay timer begins counting down.

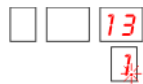

display in output test 13 while the safety delay timer is counting down, after the vibration switch is manually tripped or the test is otherwise terminated. The decimal point in the *Machine Status* window flashes during the safety delay.



terminates the test. The inverter is disabled and the basket coasts with the door latch locked for the duration of the safety delay timer (100 seconds).

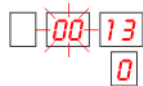

display after safety delay timer expires if the *Start* button is pressed to terminate the test.



terminates the test. The inverter is disabled and the basket coasts with the door latch locked for the duration of the safety delay timer (100 seconds).

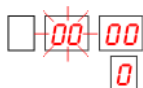

display after safety delay timer expires if the test is terminated by tripping the vibration switch or pressing the *Select* button.

— End of BICEXT02 —