

# InRow<sup>®</sup> RP

Chilled Water/Direct Expansion — 50/60 Hz



**AIR-COOLED**

**ACRP100  
ACRP101  
ACRP102**



**CHILLED WATER**

**ACRP500  
ACRP501  
ACRP502**

*Technical Data*

## **American Power Conversion Legal Disclaimer**

The information presented in this manual is not warranted by the American Power Conversion Corporation to be authoritative, error free, or complete. This publication is not meant to be a substitute for a detailed operational and site specific development plan. Therefore, American Power Conversion Corporation assumes no liability for damages, violations of codes, improper installation, system failures, or any other problems that could arise based on the use of this Publication.

The information contained in this Publication is provided as is and has been prepared solely for the purpose of evaluating data center design and construction. This Publication has been compiled in good faith by American Power Conversion Corporation. However, no representation is made or warranty given, either express or implied, as to the completeness or accuracy of the information this Publication contains.

**IN NO EVENT SHALL AMERICAN POWER CONVERSION CORPORATION BE LIABLE FOR ANY DIRECT, INDIRECT, CONSEQUENTIAL, PUNITIVE, SPECIAL, OR INCIDENTAL DAMAGES (INCLUDING, WITHOUT LIMITATION, DAMAGES FOR LOSS OF BUSINESS, CONTRACT, REVENUE, DATA, INFORMATION, OR BUSINESS INTERRUPTION) RESULTING FROM, ARISING OUT, OR IN CONNECTION WITH THE USE OF, OR INABILITY TO USE THIS PUBLICATION OR THE CONTENT, EVEN IF AMERICAN POWER CONVERSION CORPORATION HAS BEEN EXPRESSLY ADVISED OF THE POSSIBILITY OF SUCH DAMAGES. AMERICAN POWER CONVERSION CORPORATION RESERVES THE RIGHT TO MAKE CHANGES OR UPDATES WITH RESPECT TO OR IN THE CONTENT OF THE PUBLICATION OR THE FORMAT THEREOF AT ANY TIME WITHOUT NOTICE.**

Copyright, intellectual, and all other proprietary rights in the content (including but not limited to software, audio, video, text, and photographs) rests with American Power Conversion Corporation or its licensors. All rights in the content not expressly granted herein are reserved. No rights of any kind are licensed or assigned or shall otherwise pass to persons accessing this information.

This Publication shall not be for resale in whole or in part.

# Contents

---

- Overview ..... 1**
  - Capacity .....1
  - Room Air Distribution .....1
  - Configuration .....1
  - Compliance Approval .....1
  - Chilled Water Standard Features .....1
  - Air-cooled Standard Features .....1
  - Accessories .....1
  
- Scalable Solution for Critical Environments ..... 2**
  - InRow Advantages .....2
  - Scalable for High Density .....2
  - Hot Aisle Containment System .....3
  
- Standard Features..... 4**
  - Insulated Cabinet .....4
  - Variable Speed Fans .....4
  - Shutdown Input/Alarm Output .....4
  - Chilled Water Flow Meter .....4
  - 2-way/3-way Floating Point Valve (CW Only) .....4
  - Counterflow Cooling Coil/Condensate Pan .....4
  - Electric Reheat .....4
  - 30% ASHRAE 52.1 Filter .....4
  - Pipe Adapters (CW only) .....4
  - Pipe Adapters (Air-Cooled only) .....4
  - Selectable Top or Bottom Piping Connections .....4
  - Dual Position Float Condensate Management .....5
  - Network Management Card .....5
  - Bay Kit InRow RP/NetShelter SX .....5
  - Remote Temperature Sensors .....5
  - Humidifier .....5

**Optional Features ..... 6**

Cable Water Detector .....6  
Network Cable .....6  
85% ASHRAE 52.1 Filter .....6  
Power Trough .....6  
Data Partition .....6  
Height Adapters .....6  
Flex Hose Piping Kits .....6

**Microprocessor Controller ..... 7**

Microprocessor Controller .....7  
Open Architecture .....7  
Control Type .....7  
Functions .....7  
Logging .....7  
Control .....7  
Alarms .....8  
Chilled Water Only Alarms .....8  
Air-cooled Only Alarms .....8

**InRow RP Models ..... 9**

Chilled water interior components (front of unit) .....10  
Air-cooled interior components (front of unit) .....12  
Air-cooled interior components (back of unit) .....13  
Chilled water and air-cooled user interface connections .....14  
Chilled water electrical panel .....15  
Air-cooled electrical panel .....16

**Performance Specifications ..... 17**

Chilled Water Performance Specifications 5.5°C (42°F) EWT ....17  
Chilled Water Performance Specifications 7.2°C (45°F) EWT ....18  
Chilled Water Performance Specifications 8.9°C (48°F) EWT ....19  
Chilled Water Performance Specifications 10°C (50°F) EWT ....20  
Chilled Water Performance Specifications 12.8°C (55°F) EWT ...21  
Chilled Water Performance Specifications 15.5°C (60°F) EWT ...22  
Chilled Water Data - General .....23  
Glycol Correction Factors .....24  
Altitude Correction Factors for InRow Products .....24  
Air-cooled Performance Specifications .....24  
Air-cooled Data - General .....25  
Sound Performance Data .....26  
Electrical Data .....27

**Dimensional Data..... 28**

InRow RP Assembled Module ..... 28  
SX to VX Height Adapter ..... 29  
SX to 48U SX Height Adapter ..... 29

**Piping and Mechanical Connections ..... 30**

Chilled water piping diagram ..... 30  
Chilled water piping access (top) ..... 31  
Chilled water piping access (bottom) ..... 32  
Air-cooled piping diagram ..... 33  
Air-cooled piping access (top) ..... 34  
Air-cooled piping access (bottom) ..... 35

**Air-Cooled Condensers..... 36**

Mechanical Data ..... 36  
Electrical Data ..... 36  
ACCD75201 and ACCD75204 ..... 37  
ACCD75202 and ACCD75205 ..... 37  
ACCD75203 and ACCD75206 ..... 37  
ACCD75207 ..... 38  
ACCD75208 and ACCD75209 ..... 38  
Air-cooled Condenser Features ..... 38

**Guide Specifications ..... 39**

**Guidelines for Installation..... 47**

Room preparation ..... 47  
Service access ..... 47  
Receiving the unit ..... 47  
Rigging ..... 47  
Condensate Drain ..... 47



# Overview

---

The modular, row-based computer room cooling system offers efficient, predictable, and economical cooling for a variety of spaces.

Critical environmental requirements now reach far beyond the confines of the traditional data center or computer room to encompass a larger suite of applications, referred to as technology rooms. Critical environment applications include:

- Computer rooms
- Telecommunication facilities
- Clean rooms
- Power equipment
- Medical equipment rooms
- LAN/WAN environments

A worldwide network of APC representatives is fully qualified to provide engineering, sales, installation, and service for our products.

APC warrants all parts for 18 months from shipment and 12 months from startup. Extended warranties are available.

## Capacity

The InRow RP chilled water configuration is available in one size with a capacity that is up to 60 kW based on the particular application of the unit. The InRow RP air-cooled configuration is available in one size with a capacity that is up to 37 kW.

## Room Air Distribution

Row-based systems are placed in line with rack enclosures. At least one system is used per hot aisle. Air is drawn in through the rear of the system, cooled, and discharged into the cold aisle, thereby neutralizing the sensible heating effects of the data processing equipment. The InRow RP delivers high volumes of airflow to eliminate hot spots in densely populated environments.

## Configuration

- Chilled Water
- Air-cooled

## Compliance Approval

- UL Listed
- VDE
- CE
- C-tick
- C-UL Listed



## Chilled Water Standard Features

- Insulated cabinet
- Backward inclined impeller
- Variable speed fans (3)
- Shutdown input/alarm output
- Chilled water flow meter
- 2-way/3-way floating point valve
- Humidifier
- Counter flow cooling coil
- Electric reheat
- Pleated 100 mm (4 in) filter
- NPT to BSPT pipe adapters
- Top or bottom piping
- Condensate management with dual position float
- Network management card
- Baying Kit InRow RP to NetShelter® SX rack
- Remote temperature sensor (3)
- Microprocessor controller
- Automatic transfer switch

## Air-cooled Standard Features

- Insulated cabinet
- Backward inclined impeller
- Variable speed fans (2)
- Shutdown input/alarm output
- Humidifier
- Cross circuited cooling coil
- Electric reheat
- Pleated 100 mm (4 in) filter
- Pipe adapters
- Top or bottom piping
- Condensate management with dual position float
- Network management card
- Baying kit InRow RP to NetShelter® SX rack
- Remote temperature sensor (3)
- Microprocessor controller
- Variable speed reciprocating compressor using VFD control
- Liquid line solenoid valve
- Pressure equalization solenoid

## Accessories

- Cable leak detector
- Baying kit InRow RP to NetShelter VX rack
- NetShelter SX 42U to 48U height adapters
- NetShelter VX 42U height adapters
- Bridge trough power cable shield
- Data cable bridge partition
- Flex hose piping kits

# Scalable Solution for Critical Environments

---

## InRow Advantages

The row-based solution improves energy efficiency and cooling ability in a number of ways. First, the InRow RP draws air directly from the hot aisle, allowing the InRow RP to take advantage of higher heat transfer efficiency due to higher temperature differences. It can then discharge room temperature air directly in front of the servers it is cooling. This increases energy efficiency by allowing the chiller to operate at higher leaving water temperatures. Placing the cooling unit in the row enables the unit to operate at higher return and supply air temperatures, yielding 100% sensible capacity. This significantly reduces the need for humidification.

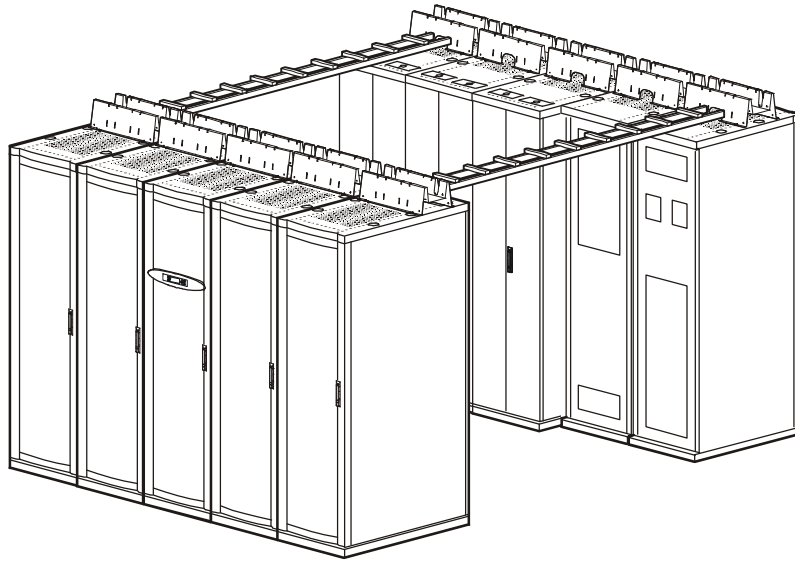

## Scalable for High Density

The predictable performance of the row-based architecture makes it well suited for high density applications. The focus on heat removal instead of cold air delivery is the key to making this approach scalable. The modular design of the InRow RP allows it to be easily added in the row as the demand for cooling increases.

The additional benefit of the row-based architecture is the ability to add hot aisle containment. Containing the hot aisle further reduces any chance of hot and cold air streams mixing. This provides ultimate predictability and allows the cooling capacity to be matched to the IT heat load.



## Hot Aisle Containment System

Modular ceiling tiles and doors can be used to enclose the hot aisle. This increases the densities that can be handled in a single rack enclosure by eliminating mixing of hot and cold air streams. This method, called load neutralization, removes the heat from the hot aisle, cools it, and then returns it to the surrounding room area at or slightly below room temperature. The warmer return air temperatures that are achieved in this application increase the capacity of the air conditioner.

Use of modular ceiling tiles across a 914.4 mm (3 ft) hot aisle that connects two opposite rack enclosures makes expansion quick and simple. Expansion kits, with necessary ceiling tile and all baying hardware, can be ordered to increase the size of the hot aisle by one rack on each side. The end doors can be easily removed and re-attached for expansion.

The enclosed hot aisle prevents any warm return air from mixing with cold supply air. In effect, all surrounding room air can act as supply air to the system. The hot aisle containment system is beneficial in any environment. It can be deployed quickly in any controlled space without expensive additions to the infrastructure, such as raised floor or ductwork.

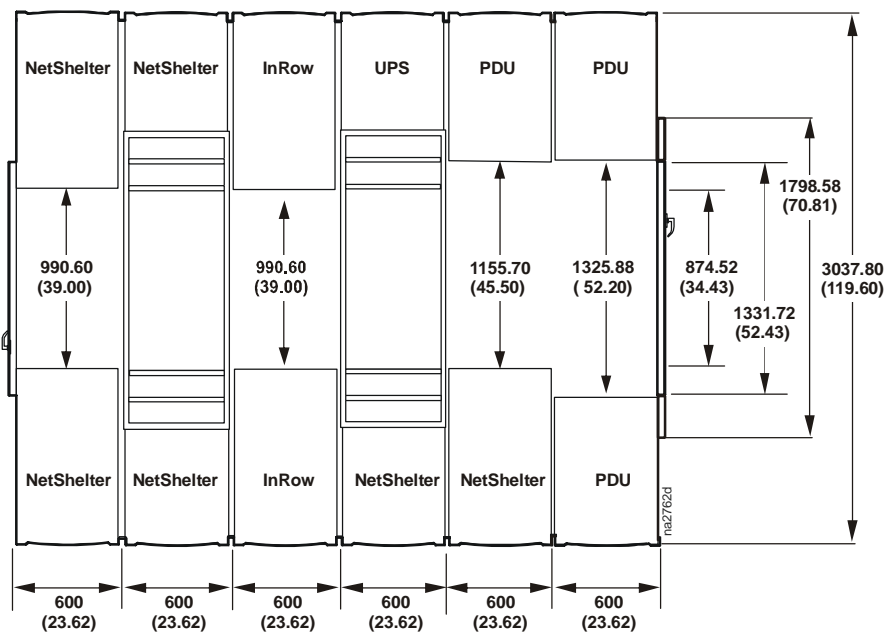
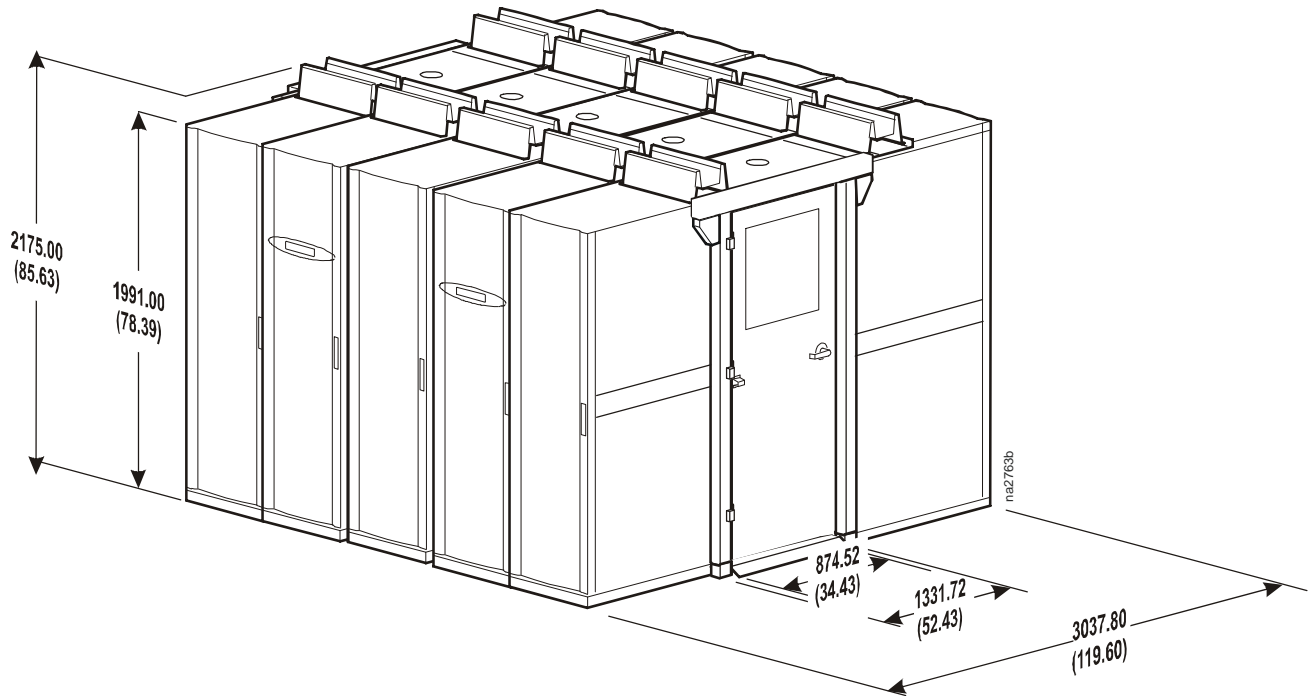

Dimensions are shown in mm (in).

# Standard Features

## Insulated Cabinet



The frame is constructed of 1.5 mm (16 gauge) formed steel for maximum strength. Cabinet is serviceable from the front and rear. All exterior panels and corner posts on the frame are powder coated for durability and an attractive finish. Front and rear exterior panel are constructed of 1.2 mm (18 gauge) perforated steel with 69.5% open free area. Insulation is 80.1 kg/m<sup>3</sup> (5 lb/ft<sup>3</sup>) density and complies with ASTM E84 rating of 25/50. All panels include a key latch for safety and security for easy access and removal.

## Variable Speed Fans

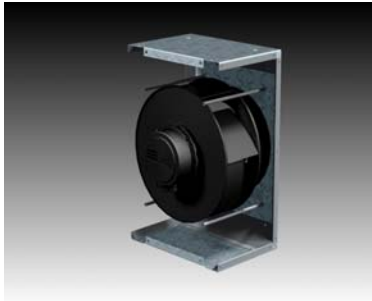

The InRow RP unit is equipped with variable speed, electrically commutated, 400-mm (15.8-in) backward incline, direct drive fans. The chilled water unit is equipped with three fans while the air-cooled unit has two. In order to provide uniform airflow over the cooling coil, the fans provide a draw-through air pattern. Fans are easily serviced in the field.

## Shutdown Input/Alarm Output

The unit provides one field connection input for remote shutdown and one field connection alarm output.

## Chilled Water Flow Meter

Internal piping of the unit includes a flow meter wired into the microprocessor controller to display chilled water flow and determine operating performance.

## 2-way/3-way Floating Point Valve (CW Only)

A floating point valve is microprocessor controlled to regulate the amount of chilled water into the cooling coil to maintain desired conditions. The standard valve pressure rating is 4136.8 kPa (600 psig). The maximum operation pressure of the unit is 2068.4 kPa (300 psig). The valve is user configurable to be two-way or three-way.

## Counterflow Cooling Coil/ Condensate Pan

Designed for high sensible heat ratios, the coil is constructed with copper tubes, raised lance type aluminum fins, and 1.2 mm (18 gauge) galvanized steel end plates. Coil headers are equipped with anti drip shields in case of condensation. Condensate pan is UL94 V-0 thermal formed non-ferrous material sloped for positive drainage for higher indoor air quality.

## Electric Reheat

Electric reheat elements are low watt density, wired for three-phase and loaded equally on all three phases, and electrically and thermally protected by both automatic and manual reset thermal cut outs. Reheat elements are stainless steel, fin tubular construction.

## 30% ASHRAE 52.1 Filter

The filtration of conditioned air is extremely vital to maintaining the clean, particle-free environment required by electrical equipment. The system uses a 30% efficient, 100 mm (4 in), deep loading, pleated filter. Deeper filters produce a lower pressure drop, requiring less energy during normal operation. The filter is moisture resistant up to a 100% relative humidity. Filters are easily replaceable from the rear of the unit. (MERV 8 per ASHRAE 52.2, EN779 G4)

## Pipe Adapters (CW only)

Standard pipe connections are 38.1 mm (1 1/2 in) NPSM (manufactured in accordance with ANSI B.1.20.1).

## Pipe Adapters (Air-Cooled only)

Standard pipe connections are 31.75 mm (1 1/4 in) 12 UNF female Rotolock (manufactured in accordance with ANSI B1.1). The adapter converts the rotolock to a sweat adapter.

## Selectable Top or Bottom Piping Connections

Unit includes both top and bottom piping connections. Top piping connects to internal stubs and routes piping upward out of the unit. Bottom piping connects to internal stubs and routes piping downward out of the unit. All connections utilize unions or rotolok fittings for ease of installation and service

### **Dual Position Float Condensate Management**

The pump is factory wired and piped internally to the condensate drain pan and humidifier outlet. The pump is capable of pumping a maximum of 18 m (60 ft) at 0.009 l/s (8.45 GPH), which may include a maximum lift of 3.5 m (11.5 ft) of head. A dual position float is included with the unit. One position is used for condensate pump control, the other to alarm condensate pump failure which shuts down the RP to prevent condensate pump overflow.

### **Network Management Card**

Permits multi-level access to monitoring, control, and event notification features over the user's network.

### **Bay Kit InRow RP/ NetShelter SX**

Baying kits made of 1.5 mm (16 gauge) steel enable baying of the cooling system to APC NetShelter SX enclosures.

### **Remote Temperature Sensors**

To control the unit based on rack inlet temperature, three remote sensors are provided. These sensors measure at 4 m (13 ft) from the connection point inside the RP. The sensors are used for remote placement in the field on adjacent IT racks.

### **Humidifier**

The humidifier is a self-contained, steam-generating type, factory piped and wired, with a disposable cylinder and an automatic solid state control circuit. Humidifier canisters are replaceable. The humidifier controller communicates directly to the microprocessor controller and provides complete status and control at the operator interface.

# Optional Features

---

## Cable Water Detector

A leak detection cable is placed on the floor or subfloor around all possible leak sources. If water or other conductive liquids contact the cable anywhere along its length, the microprocessor controller announces the leak visually, audibly, and across the network. The 6.1 m (20 ft) cable may be cascaded to make custom lengths up to 24.4 m (80 ft).

## Network Cable

Various lengths of network cable are available to ship with your cooling system. The network cable is used to interconnect multiple cooling units in a redundant group, as well as to connect the network management card to your LAN.

## 85% ASHRAE 52.1 Filter

Electrical equipment requires clean, particle free air, thus making the filtration of the air extremely important. Optionally, the system uses a 85% efficient, 100 mm (4 in), deep loading, pleated filter. Deeper filters produce a lower pressure drop, requiring less energy during normal operation. The 100% synthetic media will not absorb moisture and is resistant to most common chemicals. The filter is moisture resistant up to a 100% relative humidity. Filters are easily replaceable from the rear of the unit. (MERV 13 per ASHRAE 52.2, EN779 F7)

## Power Trough

Overhead power distribution between adjacent NetShelter racks allows for removal of the InRow RP without disrupting overhead power cabling.

## Data Partition

Overhead cable distribution between adjacent NetShelter racks allows for removal of the InRow RP without disrupting overhead cabling.

## Height Adapters

To match height of the InRow RP to various rack heights, height adapters are available for NetShelter 42U VX and 48U SX racks.

## Flex Hose Piping Kits

For hard piping to the chilled water InRow RP, stainless steel flex piping kits are available. The kits ship with two 0.914 m (3 ft) or 1.828 m (6 ft) pipes, depending on selection. Connections are 1.25 in NPT to 1.5 in NPSM, OFS female.

# Microprocessor Controller

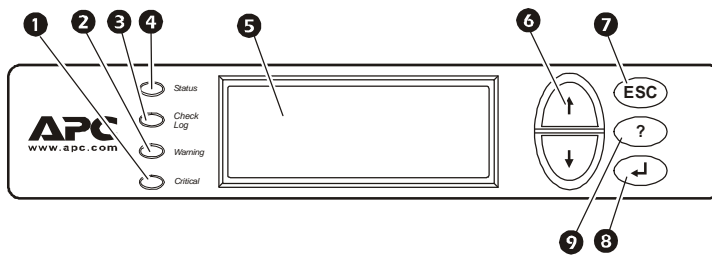

1	Critical Alarm LED
2	Warning Alarm LED
3	Check Log LED
4	Status LED
5	Liquid Crystal Display (LCD)
6	Menu Selection scroll keys
7	Escape key
8	Enter key
9	Help key

## Microprocessor Controller

The microprocessor controller is standard on each system. The controller provides precision control for the demanding requirements of:

- Computer rooms
- Telecommunication facilities
- Clean rooms
- Power equipment
- Medical equipment rooms
- LAN/WAN environments

The easy-to-use display allows the operator to select options from the device's menu-driven interface to control and monitor the connected air conditioning system.

## Open Architecture

The InRow RP protocol is open for integration with all building management systems.

Communication interface on the system can be MODBUS RS485 or Ethernet.

## Control Type

Controller utilizes proportional/integral/derivative (PID), a time-proven precision environmental control method. This allows for custom tuning of control variables to achieve desired system response.

## Functions

- Supply and Return Air Conditions
- Operational Mode Control
- Event Logging
- Alarms
- Redundant Group Control
- Fan Speed Adjustment
- Input/Output Module Programming

## Logging

The event log keeps a record of all alarms and events. Each event log contains a time/date stamp as well as operating conditions at the time of occurrence. The controller also displays run time, in hours, for major components (air filters, fans, and condensate pump, as well as humidifier, heater, and compressor for the air-cooled unit).

## Control

The backlit, four-line by twenty-character display is password configurable.

## Alarms

The microprocessor controller shall activate a visible and audible alarm in the following occurrences:

- Cool Fail
- Rack inlet temperature violation
- Rack inlet temperature sensor fault
- Air filter clogged
- Air filter run hours exceeded
- Filter DP sensor failure
- Supply air sensor fault
- Return air sensor fault
- Supply air high temperature violation
- Return air high temperature violation
- Fan fault
- Fan run hours exceeded
- Water detection fault
- Condensate pump fault
- Condensate run hours exceeded
- Humidifier water conductivity high violation
- Humidifier fault tolerance exceeded
- Humidifier low water
- Humidifier excessive output reduction
- Humidifier drain fault
- Humidifier cylinder full
- Humidifier replace cylinder
- Humidifier RS485 communication fault
- Humidifier run hours violation
- Humidity high/low violation
- Supply humidity sensor fault
- Return humidity sensor fault
- Heater fault
- Heater run hours exceeded
- Heater interlock shutdown
- Group communication fault
- Internal communication fault
- A-link isolation relay fault
- External communication fault
- Input contact fault
- Invalid supply setpoint
- Idle mode active

## Chilled Water Only Alarms

- Coil fluid valve actuator fault
- Fluid flow fault
- Entering fluid temperature high violation
- Entering fluid temperature sensor fault
- Leaving fluid temperature sensor fault
- Power source failure
- Fluid calibration

## Air-cooled Only Alarms

- High discharge pressure
- Low suction pressure
- High suction pressure
- Compressor drive failure
- Compressor drive warning
- Compressor run hours violation
- Compressor drive RS485 communication fault
- Excessive compressor cycling
- Air flow decreased while compressor off
- Suction pressure sensor failure
- Discharge pressure sensor failure
- High pressure switch active
- Fan speed decreased to avoid high pressure (event only)
- Compressor speed decreased to avoid high pressure (event only)
- Compressor high pressure
- Oil return pump active

# InRow RP Models

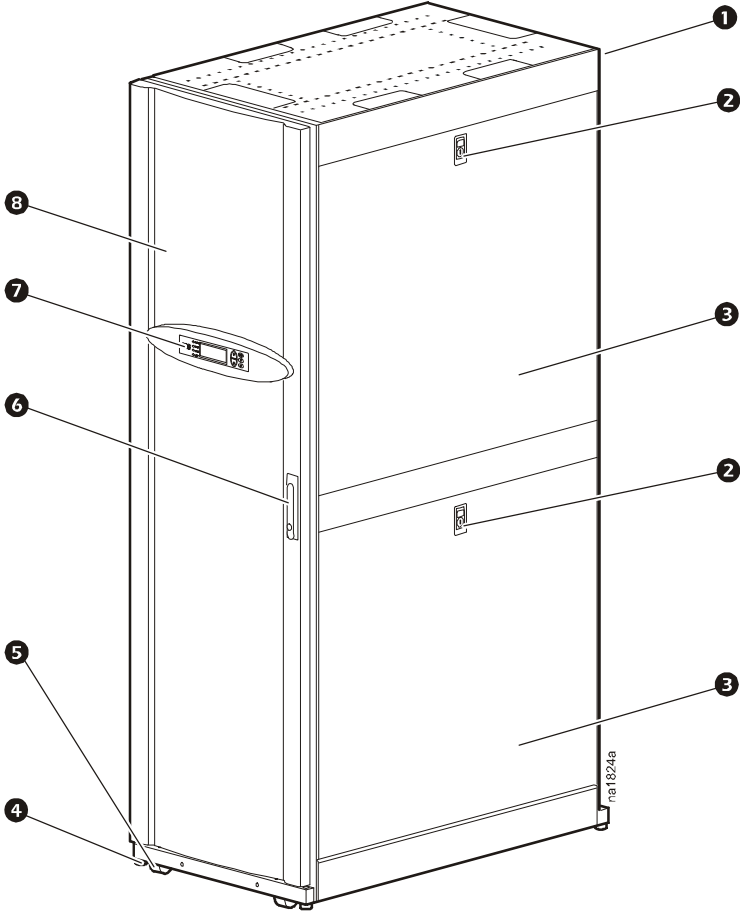

- 1 Hinged rear doors
- 2 Side panel lock
- 3 Removable side panel
- 4 Adjustable leveling foot
- 5 Casters (all swiveling)
- 6 Door handle and lock
- 7 Display interface
- 8 Hinged front door

## Chilled water interior components (front of unit)

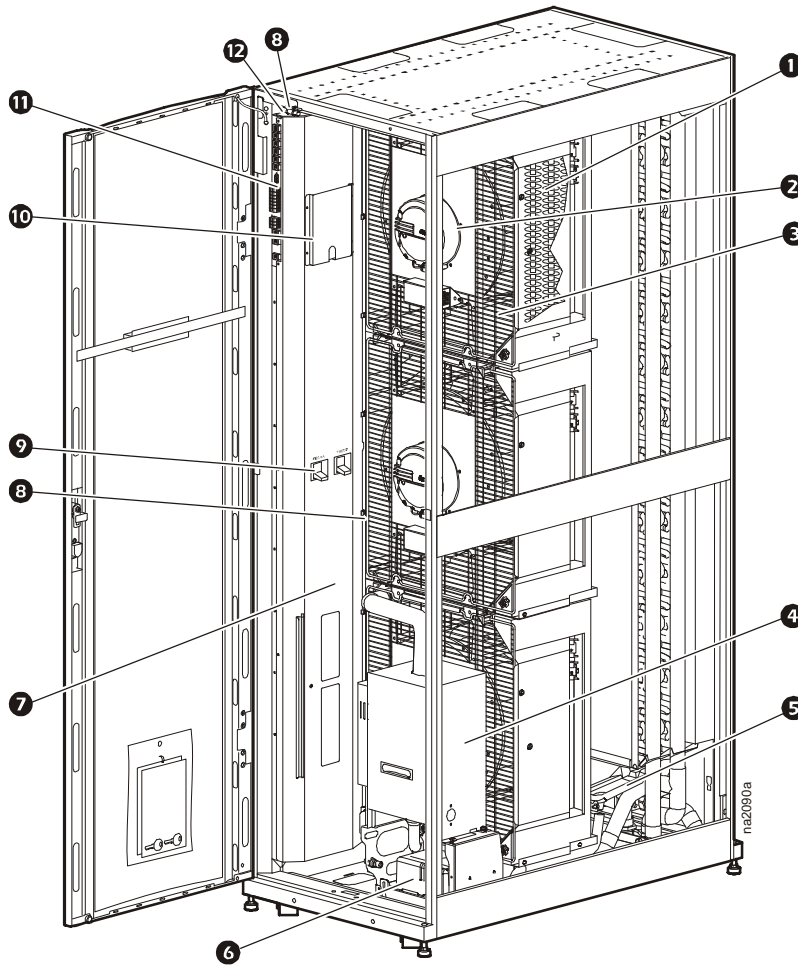

- |                                |                              |
|--------------------------------|------------------------------|
| ① Electric heater (for reheat) | ⑦ Electrical panel           |
| ② Fan                          | ⑧ Supply temperature sensors |
| ③ Fan guard                    | ⑨ Main feed breakers         |
| ④ Humidifier                   | ⑩ Ladder diagrams            |
| ⑤ Condensate drain pan         | ⑪ User interface connectors  |
| ⑥ Condensate pump              | ⑫ Supply humidity sensor     |



## Chilled water interior components (back of unit)

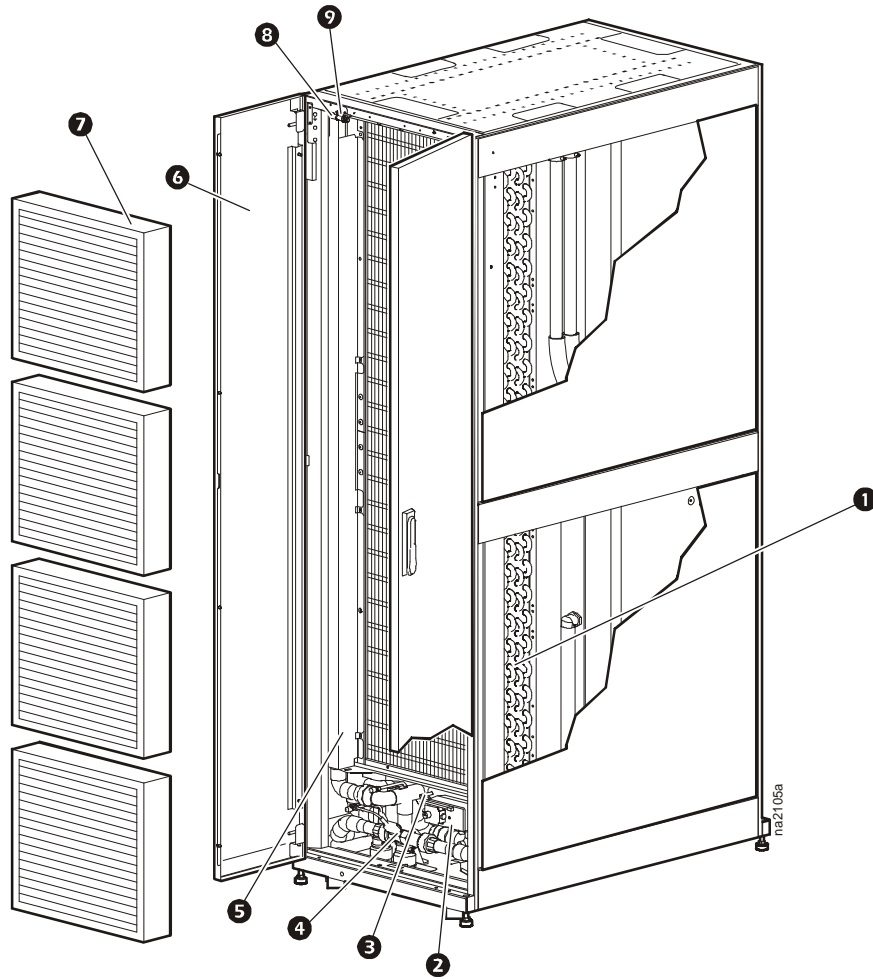

- |                                      |                             |
|--------------------------------------|-----------------------------|
| ❶ Chilled water coil                 | ❸ Rear doors                |
| ❷ Chilled water control actuator     | ❹ Air filters               |
| ❸ Chilled water three-way valve body | ❺ Return humidity sensor    |
| ❹ Flow meter                         | ❻ Return temperature sensor |
| ❺ Pipe chase                         |                             |

## Air-cooled interior components (front of unit)

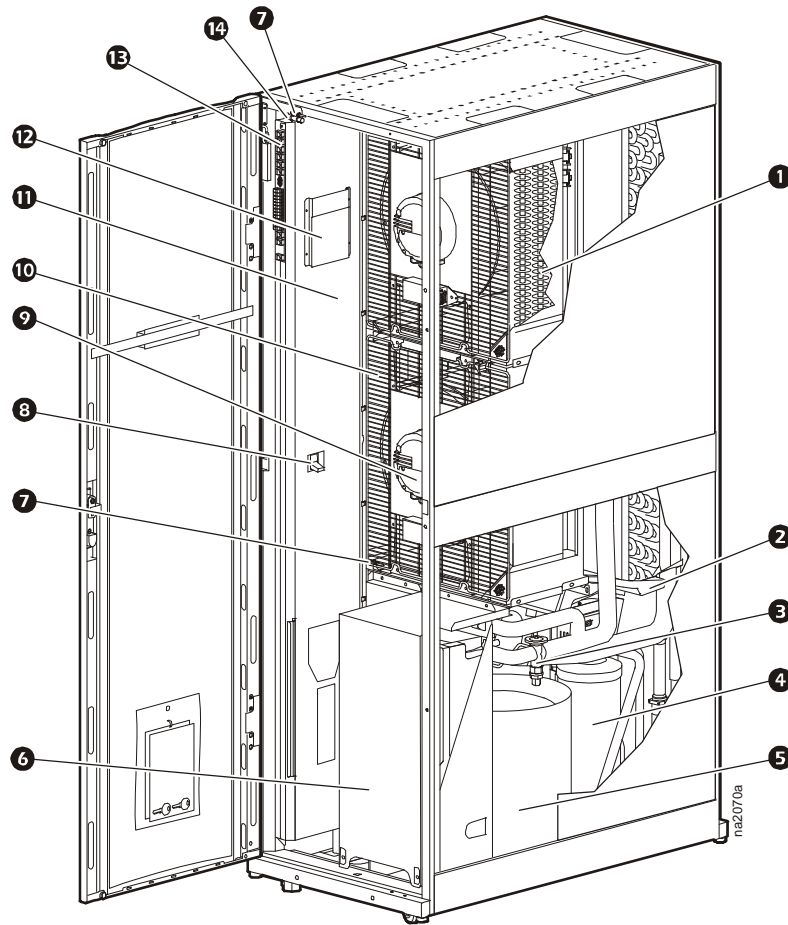

- |   |  |
|---|--|
| ① Electric heater (for reheat)              | ⑧ Main circuit breaker                         |
| ② Condensate drain pan                      | ⑨ Fan  |
| ③ Thermal expansion valve                   | ⑩ Fan guard                                    |
| ④ Receiver                                  | ⑪ Electrical panel                             |
| ⑤ Compressor                                | ⑫ Ladder diagrams                              |
| ⑥ Variable Frequency Drive (for compressor) | ⑬ Communication and external device connectors |
| ⑦ Supply air temperature sensor             | ⑭ Humidity sensor                              |

## Air-cooled interior components (back of unit)

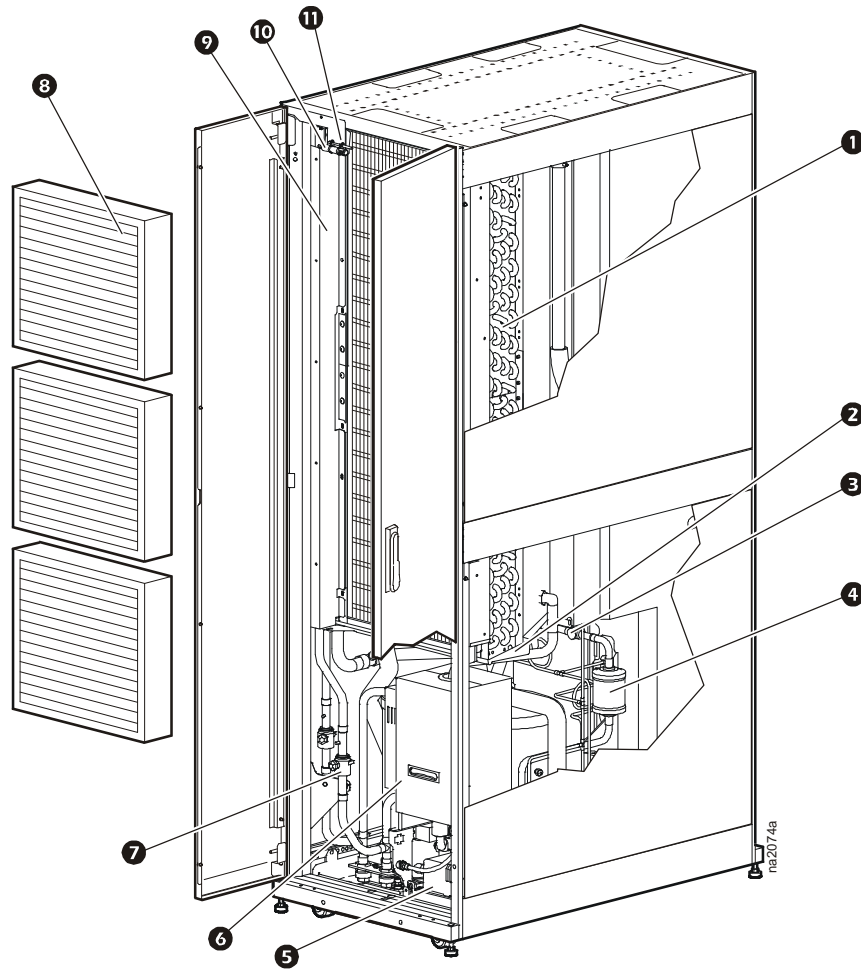

- |   |                      |   |                                  |
|---|----------------------|---|----------------------------------|
| ❶ | Evaporator coil      | ❷ | Shutoff valves (top piping only) |
| ❸ | Condensate drain pan | ❸ | Air filters                      |
| ❹ | Sight glass          | ❹ | Pipe chase                       |
| ❺ | Filter dryer         | ❺ | Humidity sensor                  |
| ❻ | Condensate pump      | ❻ | Return air temperature sensor    |
| ❼ | Humidifier           |   |                                  |

## Chilled water and air-cooled user interface connections

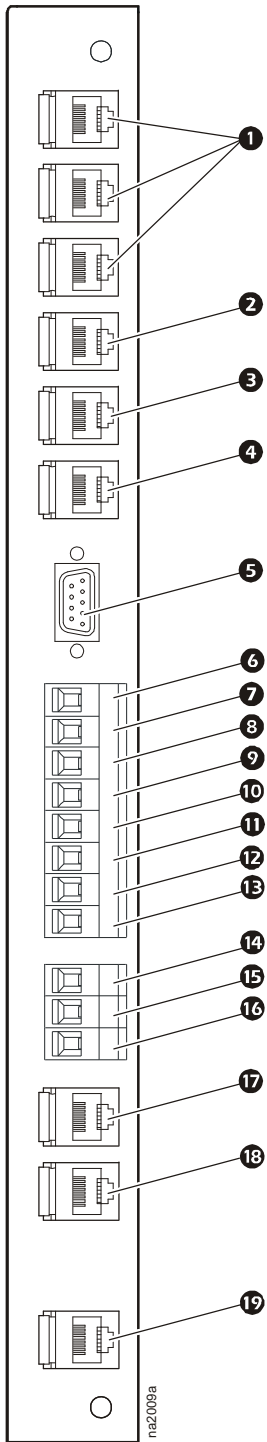

- ❶ Rack inlet temperature sensors 1, 2, 3
- ❷ A-Link IN
- ❸ A-Link OUT
- ❹ Network port
- ❺ Console port
- ❻ Alarm output, NC (Normally Closed)
- ❼ Alarm output, COM (Common)
- ❽ Alarm output, NO (Normally Open)
- ❾ Supply GND (Ground)
- ❿ Supply 12 Vdc (current limit: 20 mA)
- ⓫ Supply 24 Vdc (current limit: 20 mA)
- ⓬ Customer input + (12–30 Vac/Vdc, 24 Vdc @ 11 mA)
- ⓭ Supply COM
- ⓮ BMS D1 (RXTX+)
- ⓯ BMS D0 (RXTX–)
- ⓰ BMS GND
- ⓱ Supply air temperature sensor (front)
- ⓲ Supply air humidity sensor (front)
- ⓳ Display interface



**Note:** For a top installation, control wiring is routed through the wire channel located at the top left hand corner just above the user interface connectors.

For a bottom installation, the control wiring is routed to the access hole in the bottom of the equipment through wire clamps from the interface connectors. Then, the wiring is routed down along the electrical panel and secured with wire clamps.

## Chilled water electrical panel



**Note:** ACRP 501 shown.

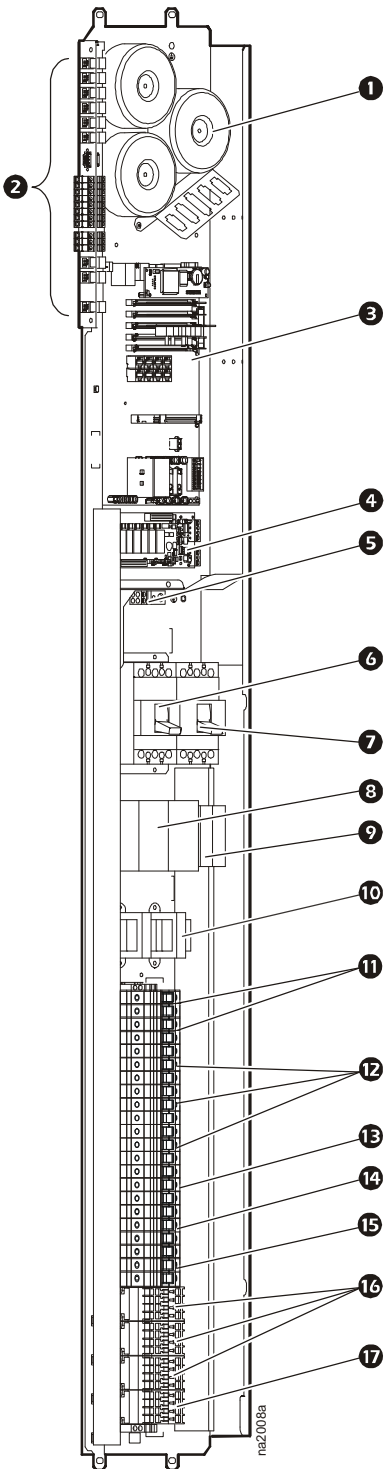

- ❶ Transformers
- ❷ User interface connectors
- ❸ Main controller board
- ❹ Relay board
- ❺ Ground lug
- ❻ Main circuit breaker — power feed A
- ❼ Main circuit breaker — power feed B
- ❽ Automatic transfer switch (ATS) contactors
- ❾ ATS timers
- ❿ ATS transformer (ACRP501 only)
- ⓫ ATS timer circuit breakers
- ⓬ Fan circuit breakers
- ⓭ Controller circuit breaker
- ⓮ Humidifier circuit breaker
- ⓯ Heater circuit breaker
- ⓰ Heater contactors
- ⓱ Humidifier contactor

## Air-cooled electrical panel



**Note:** ACRP 101 shown.

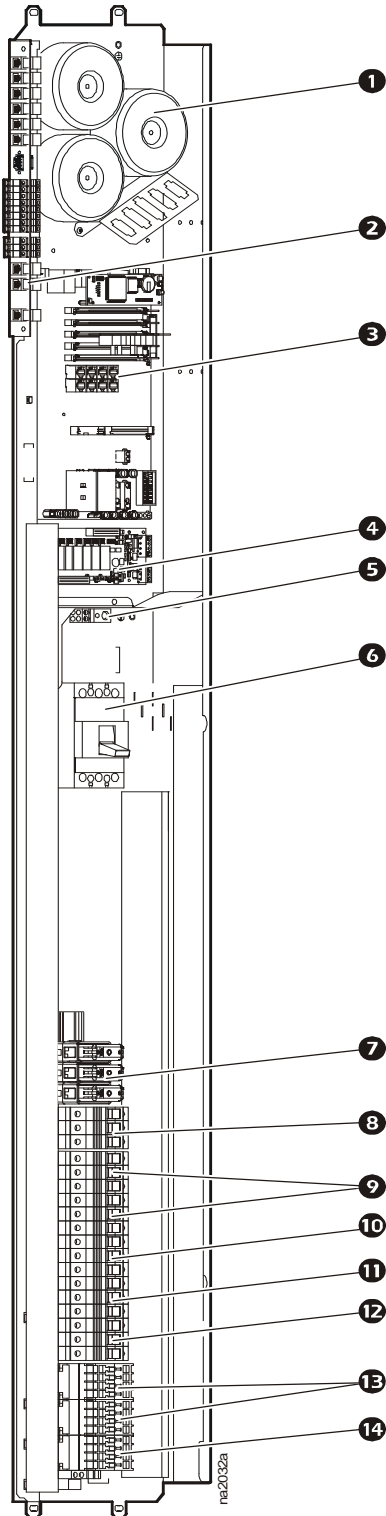

- ❶ Transformers
- ❷ User interface connectors
- ❸ Main controller board
- ❹ Relay board
- ❺ Ground lug
- ❻ Main circuit breaker
- ❼ Compressor fuse block (ACRP100, ACRP101)
- ❽ Compressor circuit breaker (ACRP102)
- ❾ Fan circuit breakers
- ❿ Controller circuit breaker
- ⓫ Humidifier circuit breaker
- ⓬ Heater circuit breaker
- ⓭ Heater contactors
- ⓮ Humidifier contactor

# Performance Specifications

## Chilled Water Performance Specifications 5.5°C (42°F) EWT

Temperature dry bulb (DB), wet bulb (WB) °C (°F)	CW Delta T °C (°F)	Total Net Capacity kW (BTU/hr)	Sensible Net Capacity kW (BTU/hr)	Sensible Heat Ratio SHR	CW Flow Rate l/s (GPM)	Total CW Pressure Drop kPa (ft H <sub>2</sub> O)*
<b>26.7°C DB, 17.1°C WB (80°F DB, 62.8°F WB)</b>						
	6.6 (12)	44.3 (151,000)	40.7 (139,000)	0.92	1.6 (25.9)	66 (21.95)
	7.7 (14)	40.8 (139,000)	37.9 (129,000)	0.93	1.3 (20.6)	42 (14.1)
	8.8 (16)	37.8 (129,000)	35.2 (120,000)	0.93	1.1 (16.8)	29 (9.5)
	10 (18)	34.6 (118,000)	32.5 (111,000)	0.94	0.9 (13.8)	19 (6.5)
	11.1 (20)	31.8 (109,000)	29.9 (102,000)	0.94	0.7 (11.5)	14 (4.6)
<b>29.4°C DB, 18.1°C WB (85°F DB, 64.5°F WB)</b>						
	6.6 (12)	50.8 (174,000)	47.8 (163,000)	0.94	1.9 (29.5)	84 (28.4)
	7.7 (14)	47.7 (163,000)	44.8 (153,000)	0.94	1.5 (23.9)	56 (18.7)
	8.8 (16)	44.1 (151,000)	41.9 (143,000)	0.95	1.2 (19.4)	38 (12.5)
	10 (18)	41.2 (141,000)	39.1 (134,000)	0.95	1.0 (16.2)	26 (8.8)
	11.1 (20)	37.8 (129,000)	36.3 (124,000)	0.96	0.8 (13.5)	19 (6.2)
<b>32.2°C DB, 18.9°C WB (90°F DB, 66.1°F WB)</b>						
	7.7 (14)	54.5 (186,000)	52.3 (179,000)	0.96	1.7 (27.1)	71 (23.8)
	8.8 (16)	51.4 (175,000)	49.3 (168,000)	0.96	1.4 (22.4)	49 (16.6)
	10 (18)	47.8 (163,000)	46.3 (158,000)	0.97	1.2 (18.6)	35 (11.6)
	11.1 (20)	44.8 (153,000)	43.4 (148,000)	0.97	1.0 (15.7)	25 (8.32)
<b>35.0°C DB, 19.8°C WB (95°F DB, 67.7°F WB)</b>						
	7.7 (14)	62.0 (212,000)	60.2 (205,000)	0.97	1.9 (30.6)	90 (30.3)
	8.8 (16)	58.8 (201,000)	57.0 (195,000)	0.97	1.6 (25.4)	63 (21.3)
	10 (18)	55.6 (190,000)	53.9 (184,000)	0.97	1.4 (21.4)	45 (15.2)
	11.1 (20)	52.4 (179,000)	50.9 (174,000)	0.97	1.2 (18.3)	33 (11.1)
<b>37.8°C DB, 20.7°C WB (100°F DB, 69.2°F WB)</b>						
	8.8 (16)	66.4 (227,000)	65.0 (222,000)	0.98	1.8 (28.6)	79 (26.6)
	10 (18)	63.1 (215,000)	61.8 (211,000)	0.98	1.5 (24.2)	57 (19.2)
	11.1 (20)	59.8 (204,000)	58.7 (200,000)	0.98	1.3 (20.7)	42 (14.3)
<b>40.6°C DB, 21.6°C WB (105°F DB, 70.8°F WB)</b>						
	10 (18)	71.4 (244,000)	70.0 (239,000)	0.98	1.7 (27.3)	72 (24.3)
	11.1 (20)	68.1 (233,000)	66.7 (228,000)	0.98	1.5 (23.4)	54 (18.02)

Note: All values are accurate to +/- 5% and based on full speed with standard filters

Note: Any CW flow rate of 0.19 l/s - 0.32 l/s (3.0 GPM - 5.0 GPM) may cause an increased error in flow rate and power calculation. A fluid flow fault may result. Any flow rate under 0.19 l/s (3.0 GPM) may also display as 0 in the flow rate and power calculation.

Note: For sustained operation, a maximum flow rate of 2.2 l/s (34 GPM) is recommended. This may be exceeded by 25% for peak conditions.

\* To convert feet of water to PSIG, use the following formula: ft H<sub>2</sub>O ÷ 2.307 = PSIG

## Chilled Water Performance Specifications 7.2°C (45°F) EWT

Temperature dry bulb (DB), wet bulb (WB) °C (°F)	CW Delta T °C (°F)	Total Net Capacity kW (BTU/hr)	Sensible Net Capacity kW (BTU/hr)	Sensible Heat Ratio SHR	CW Flow Rate l/s (GPM)	Total CW Pressure Drop kPa (ft H <sub>2</sub> O)*
<b>26.7°C DB, 17.1°C WB (80°F DB, 62.8°F WB)</b>						
	5.5 (10)	40.8 (139,000)	39.6 (135,000)	0.97	1.8 (28.8)	81 (27.03)
	6.6 (12)	37.9 (130,000)	36.8 (126,000)	0.97	1.4 (22.5)	50 (16.6)
	7.7 (14)	35.1 (120,000)	34.1 (116,000)	0.97	1.1 (18.0)	32 (10.9)
	8.8 (16)	32.5 (111,000)	31.5 (108,000)	0.97	0.9 (14.6)	22 (7.4)
	10 (18)	29.8 (102,000)	28.9 (99,000)	0.97	0.8 (12.0)	15 (5.1)
	11.1 (20)	27.3 (93,000)	26.5 (90,000)	0.97	0.6 (10.0)	11 (3.7)
<b>29.4°C DB, 18.1°C WB (85°F DB, 64.5°F WB)</b>						
	6.6 (12)	45.0 (154,000)	43.7 (149,000)	0.97	1.7 (26.4)	68 (22.6)
	7.7 (14)	42.0 (144,000)	40.8 (139,000)	0.97	1.3 (21.2)	44 (14.8)
	8.8 (16)	39.1 (134,000)	38.0 (130,000)	0.97	1.1 (17.4)	30 (10.2)
	10 (18)	36.3 (124,000)	35.2 (120,000)	0.97	0.9 (14.4)	21 (7.2)
	11.1 (20)	33.3 (114,000)	32.6 (111,000)	0.98	0.8 (11.9)	15 (5.1)
<b>32.2°C DB, 18.9°C WB (90°F DB, 66.1°F WB)</b>						
	6.6 (12)	52.3 (179,000)	51.2 (175,000)	0.98	1.9 (30.4)	89 (29.8)
	7.7 (14)	49.2 (168,000)	48.2 (165,000)	0.98	1.5 (24.5)	59 (19.9)
	8.8 (16)	46.1 (157,000)	45.2 (154,000)	0.98	1.3 (20.2)	41 (13.6)
	10 (18)	42.7 (146,000)	42.3 (144,000)	0.99	1.1 (16.7)	28 (9.5)
	11.1 (20)	39.8 (136,000)	39.4 (135,000)	0.99	0.9 (14.1)	20 (6.9)
<b>35.0°C DB, 19.8°C WB (95°F DB, 67.7°F WB)</b>						
	7.7 (14)	57.2 (195,000)	56.0 (191,000)	0.98	1.8 (28.3)	78 (26.1)
	8.8 (16)	53.4 (182,000)	52.9 (181,000)	0.99	1.5 (23.2)	53 (17.8)
	10 (18)	50.3 (172,000)	49.8 (170,000)	0.99	1.2 (19.5)	38 (12.7)
	11.1 (20)	47.2 (161,000)	46.7 (160,000)	0.99	1.0 (16.5)	28 (9.2)
<b>37.8°C DB, 20.7°C WB (100°F DB, 69.2°F WB)</b>						
	8.8 (16)	61.6 (210,000)	61.0 (208,000)	0.99	1.7 (26.6)	69 (23.1)
	10 (18)	58.3 (199,000)	57.7 (197,000)	0.99	1.4 (22.4)	50 (16.6)
	11.1 (20)	55.1 (188,000)	54.5 (186,000)	0.99	1.2 (19.1)	36 (12.2)
<b>40.6°C DB, 21.6°C WB (105°F DB, 70.8°F WB)</b>						
	8.8 (16)	69.6 (238,000)	69.6 (238,000)	1.00	1.9 (29.9)	86 (28.9)
	10 (18)	66.1 (226,000)	66.1 (226,000)	1.00	1.6 (25.3)	63 (21.02)
	11.1 (20)	62.7 (214,000)	62.7 (214,000)	1.00	1.4 (21.7)	46 (15.5)

Note: All values are accurate to +/- 5% and based on full speed with standard filters

Note: Any CW flow rate of 0.19 l/s - 0.32 l/s (3.0 GPM - 5.0 GPM) may cause an increased error in flow rate and power calculation. A fluid flow fault may result. Any flow rate under 0.19 l/s (3.0 GPM) may also display as 0 in the flow rate and power calculation.

Note: For sustained operation, a maximum flow rate of 2.2 l/s (34 GPM) is recommended. This may be exceeded by 25% for peak conditions.

\* To convert feet of water to PSIG, use the following formula: ft H<sub>2</sub>O ÷ 2.307 = PSIG



## Chilled Water Performance Specifications 8.9°C (48°F) EWT

Temperature dry bulb (DB), wet bulb (WB) °C (°F)	CW Delta T °C (°F)	Total Net Capacity kW (BTU/hr)	Sensible Net Capacity kW (BTU/hr)	Sensible Heat Ratio SHR	CW Flow Rate l/s (GPM)	Total CW Pressure Drop kPa (ft H <sub>2</sub> O)*
<b>26.7°C DB, 17.1°C WB (80°F DB, 62.8°F WB)</b>						
	5.5 (10)	35.7 (122,000)	34.6 (118,000)	0.97	1.6 (25.5)	63 (21.3)
	6.6 (12)	32.9 (112,000)	31.9 (109,000)	0.97	1.2 (19.7)	39 (12.9)
	7.7 (14)	30.3 (103,000)	29.4 (100,000)	0.97	1.0 (15.7)	25 (8.3)
	8.8 (16)	27.7 (95,000)	26.9 (92,000)	0.97	0.8 (12.7)	17 (5.5)
	10 (18)	25.3 (86,000)	24.5 (84,000)	0.97	0.7 (10.4)	11 (3.9)
	11.1 (20)	22.7 (78,000)	22.3 (76,000)	0.98	0.5 (8.5)	8 (2.5)
<b>29.4°C DB, 18.1°C WB (85°F DB, 64.5°F WB)</b>						
	5.5 (10)	42.3 (145,000)	41.5 (142,000)	0.98	1.9 (29.9)	86 (28.9)
	6.6 (12)	39.4 (134,000)	38.6 (132,000)	0.98	1.5 (23.3)	53 (17.8)
	7.7 (14)	36.5 (125,000)	35.8 (122,000)	0.98	1.2 (18.6)	35 (11.6)
	8.8 (16)	33.7 (115,000)	33.1 (113,000)	0.98	1.0 (15.1)	23 (7.9)
	10 (18)	31.1 (106,000)	30.4 (104,000)	0.98	0.8 (12.5)	16 (5.3)
	11.1 (20)	28.5 (97,000)	27.9 (95,000)	0.98	0.7 (10.4)	12 (3.9)
<b>32.2°C DB, 18.9°C WB (90°F DB, 66.1°F WB)</b>						
	6.6 (12)	47.0 (161,000)	46.1 (157,000)	0.98	1.7 (27.5)	73 (24.5)
	7.7 (14)	43.9 (150,000)	43.0 (147,000)	0.98	1.4 (22.1)	48 (16.2)
	8.8 (16)	40.9 (140,000)	40.1 (137,000)	0.98	1.1 (18.1)	33 (10.9)
	10 (18)	37.6 (128,000)	37.2 (127,000)	0.99	0.9 (14.9)	23 (7.6)
	11.1 (20)	34.8 (119,000)	34.4 (118,000)	0.99	0.8 (12.5)	16 (5.3)
<b>35.0°C DB, 19.8°C WB (95°F DB, 67.7°F WB)</b>						
	7.7 (14)	51.4 (176,000)	50.9 (174,000)	0.99	1.6 (25.6)	64 (21.5)
	8.8 (16)	48.2 (165,000)	47.7 (163,000)	0.99	1.3 (21.1)	44 (14.8)
	10 (18)	45.0 (154,000)	44.6 (152,000)	0.99	1.1 (17.6)	31 (10.4)
	11.1 (20)	42.0 (143,000)	41.6 (142,000)	0.99	0.9 (14.8)	22 (7.6)
<b>37.8°C DB, 20.7°C WB (100°F DB, 69.2°F WB)</b>						
	7.7 (14)	60.0 (205,000)	59.4 (203,000)	0.99	1.9 (29.7)	85 (28.6)
	8.8 (16)	56.0 (191,000)	56.0 (191,000)	1.00	1.5 (24.3)	58 (19.4)
	10 (18)	52.6 (180,000)	52.6 (180,000)	1.00	1.3 (20.4)	41 (13.9)
	11.1 (20)	49.4 (169,000)	49.4 (169,000)	1.00	1.1 (17.3)	30 (9.9)
<b>40.6°C DB, 21.6°C WB (105°F DB, 70.8°F WB)</b>						
	7.7 (14)	68.6 (234,000)	68.6 (234,000)	1.00	2.1 (33.7)	109 (36.5)
	8.8 (16)	64.9 (222,000)	64.9 (222,000)	1.00	1.8 (28.0)	76 (25.4)
	10 (18)	61.3 (209,000)	61.3 (209,000)	1.00	1.5 (23.5)	54 (18.2)

Note: All values are accurate to +/- 5% and based on full speed with standard filters

Note: Any CW flow rate of 0.19 l/s - 0.32 l/s (3.0 GPM - 5.0 GPM) may cause an increased error in flow rate and power calculation. A fluid flow fault may result. Any flow rate under 0.19 l/s (3.0 GPM) may also display as 0 in the flow rate and power calculation.

Note: For sustained operation, a maximum flow rate of 2.2 l/s (34 GPM) is recommended. This may be exceeded by 25% for peak conditions.

\* To convert feet of water to PSIG, use the following formula: ft H<sub>2</sub>O ÷ 2.307 = PSIG

## Chilled Water Performance Specifications 10°C (50°F) EWT

Temperature dry bulb (DB), wet bulb (WB) °C (°F)	CW Delta T °C (°F)	Total Net Capacity kW (BTU/hr)	Sensible Net Capacity kW (BTU/hr)	Sensible Heat Ratio SHR	CW Flow Rate l/s (GPM)	Total CW Pressure Drop kPa (ft H <sub>2</sub> O)*
<b>26.7°C DB, 17.1°C WB (80°F DB, 62.8°F WB)</b>						
	5.5 (10)	32.6 (111,000)	31.8 (109,000)	0.98	1.5 (23.5)	54 (18.02)
	6.6 (12)	29.9 (102,000)	29.2 (100,000)	0.98	1.1 (18.1)	33 (11.1)
	7.7 (14)	27.4 (93,000)	26.7 (91,000)	0.98	0.9 (14.3)	21 (6.9)
	8.8 (16)	24.9 (85,000)	24.3 (83,000)	0.98	0.7 (11.5)	14 (4.6)
	10 (18)	22.6 (77,000)	22.0 (75,000)	0.98	0.6 (9.4)	10 (3.2)
	11.1 (20)	20.4 (70,000)	19.9 (68,000)	0.98	0.5 (7.7)	7 (2.3)
<b>29.4°C DB, 18.1°C WB (85°F DB, 64.5°F WB)</b>						
	5.5 (10)	39.6 (135,000)	38.6 (132,000)	0.98	1.8 (28.0)	76 (25.6)
	6.6 (12)	36.6 (125,000)	35.7 (122,000)	0.98	1.4 (21.8)	47 (15.7)
	7.7 (14)	33.8 (115,000)	32.9 (112,000)	0.98	1.1 (17.3)	30 (10.2)
	8.8 (16)	31.1 (106,000)	30.3 (103,000)	0.98	0.9 (14.0)	20 (6.7)
	10 (18)	28.5 (97,000)	27.7 (95,000)	0.98	0.7 (11.5)	14 (4.6)
	11.1 (20)	26.0 (89,000)	25.3 (86,000)	0.98	0.6 (9.5)	10 (3.2)
<b>32.2°C DB, 18.9°C WB (90°F DB, 66.1°F WB)</b>						
	6.6 (12)	43.6 (149,000)	43.2 (147,000)	0.99	1.6 (25.6)	64 (21.5)
	7.7 (14)	40.5 (138,000)	40.1 (137,000)	0.99	1.3 (20.5)	42 (13.9)
	8.8 (16)	37.6 (128,000)	37.2 (127,000)	0.99	1.1 (16.7)	28 (9.5)
	10 (18)	34.7 (119,000)	34.4 (117,000)	0.99	0.9 (13.8)	20 (6.5)
	11.1 (20)	32.0 (109,000)	31.7 (108,000)	0.99	0.7 (11.5)	14 (4.6)
<b>35.0°C DB, 19.8°C WB (95°F DB, 67.7°F WB)</b>						
	6.6 (12)	51.9 (177,000)	51.4 (175,000)	0.99	1.9 (30.1)	88 (29.3)
	7.7 (14)	48.5 (166,000)	48.0 (164,000)	0.99	1.5 (24.2)	58 (19.4)
	8.8 (16)	45.3 (155,000)	44.8 (153,000)	0.99	1.3 (19.9)	39 (13.2)
	10 (18)	42.1 (144,000)	41.7 (142,000)	0.99	1.0 (16.5)	28 (9.2)
	11.1 (20)	38.7 (132,000)	38.7 (132,000)	1.00	0.9 (13.7)	19 (6.5)
<b>37.8°C DB, 20.7°C WB (100°F DB, 69.2°F WB)</b>						
	7.7 (14)	56.7 (194,000)	56.7 (194,000)	1.00	1.8 (28.1)	77 (25.6)
	8.8 (16)	53.2 (182,000)	53.2 (182,000)	1.00	1.5 (23.1)	53 (17.6)
	10 (18)	49.8 (170,000)	49.8 (170,000)	1.00	1.2 (19.3)	37 (12.5)
<b>40.6°C DB, 21.6°C WB (105°F DB, 70.8°F WB)</b>						
	8.8 (16)	62.3 (213,000)	62.3 (213,000)	1.00	1.7 (26.9)	70 (23.6)

Note: All values are accurate to +/- 5% and based on full speed with standard filters

Note: Any CW flow rate of 0.19 l/s - 0.32 l/s (3.0 GPM - 5.0 GPM) may cause an increased error in flow rate and power calculation. A fluid flow fault may result. Any flow rate under 0.19 l/s (3.0 GPM) may also display as 0 in the flow rate and power calculation.

Note: For sustained operation, a maximum flow rate of 2.2 l/s (34 GPM) is recommended. This may be exceeded by 25% for peak conditions.

\* To convert feet of water to PSIG, use the following formula: ft H<sub>2</sub>O ÷ 2.307 = PSIG

## Chilled Water Performance Specifications 12.8°C (55°F) EWT

Temperature dry bulb (DB), wet bulb (WB) °C (°F)	CW Delta T °C (°F)	Total Net Capacity kW (BTU/hr)	Sensible Net Capacity kW (BTU/hr)	Sensible Heat Ratio SHR	CW Flow Rate l/s (GPM)	Total CW Pressure Drop kPa (ft H <sub>2</sub> O)*
<b>26.7°C DB, 17.1°C WB (80°F DB, 62.8°F WB)</b>						
	5.5 (10)	24.7 (85,000)	24.7 (85,000)	1.00	1.2 (18.3)	33 (11.3)
	6.6 (12)	22.3 (76,000)	22.3 (76,000)	1.00	0.9 (13.9)	20 (6.7)
	7.7 (14)	20.0 (68,000)	20.0 (68,000)	1.00	0.7 (10.8)	12 (4.2)
	8.8 (16)	17.8 (61,000)	17.8 (61,000)	1.00	0.5 (8.6)	8 (2.8)
	10 (18)	15.8 (54,000)	15.8 (54,000)	1.00	0.4 (6.9)	5 (1.8)
	11.1 (20)	13.9 (48,000)	13.9 (48,000)	1.00	0.4 (5.6)	4 (1.2)
<b>29.4°C DB, 18.1°C WB (85°F DB, 64.5°F WB)</b>						
	5.5 (10)	31.3 (107,000)	31.3 (107,000)	1.00	1.4 (22.6)	50 (16.9)
	6.6 (12)	28.5 (97,000)	28.5 (97,000)	1.00	1.1 (17.3)	30 (10.2)
	7.7 (14)	25.8 (88,000)	25.8 (88,000)	1.00	0.9 (13.6)	19 (6.5)
	8.8 (16)	23.3 (80,000)	23.3 (80,000)	1.00	0.7 (10.8)	8 (4.2)
	10 (18)	21.0 (72,000)	21.0 (72,000)	1.00	0.6 (8.8)	8 (2.8)
	11.1 (20)	18.7 (64,000)	18.7 (64,000)	1.00	0.5 (7.2)	6 (1.8)
<b>32.2°C DB, 18.9°C WB (90°F DB, 66.1°F WB)</b>						
	5.5 (10)	39.1 (133,000)	39.1 (133,000)	1.00	1.7 (27.7)	75 (24.9)
	6.6 (12)	35.9 (123,000)	35.9 (123,000)	1.00	1.3 (21.3)	45 (15.02)
	7.7 (14)	32.8 (112,000)	32.8 (112,000)	1.00	1.1 (16.9)	29 (9.7)
	8.8 (16)	30.0 (102,000)	30.0 (102,000)	1.00	0.9 (13.6)	19 (6.5)
	10 (18)	27.2 (93,000)	27.2 (93,000)	1.00	0.7 (11.1)	13 (4.4)
<b>35.0°C DB, 19.8°C WB (95°F DB, 67.7°F WB)</b>						
	6.6 (12)	44.2 (151,000)	44.2 (151,000)	1.00	1.6 (25.9)	66 (21.9)
	7.7 (14)	40.8 (139,000)	40.8 (139,000)	1.00	1.3 (20.6)	42 (14.1)
	8.8 (16)	37.5 (128,000)	37.5 (128,000)	1.00	1.1 (16.7)	28 (9.5)
<b>37.8°C DB, 20.7°C WB (100°F DB, 69.2°F WB)</b>						
	7.7 (14)	49.8 (170,000)	49.8 (170,000)	1.00	1.6 (24.8)	60 (20.1)
<b>40.6°C DB, 21.6°C WB (105°F DB, 70.8°F WB)</b>						
	7.7 (14)	59.7 (204,000)	59.7 (204,000)	1.00	1.9 (29.5)	84 (28.2)

Note: All values are accurate to +/- 5% and based on full speed with standard filters

Note: Any CW flow rate of 0.19 l/s - 0.32 l/s (3.0 GPM - 5.0 GPM) may cause an increased error in flow rate and power calculation. A fluid flow fault may result. Any flow rate under 0.19 l/s (3.0 GPM) may also display as 0 in the flow rate and power calculation.

Note: For sustained operation, a maximum flow rate of 2.2 l/s (34 GPM) is recommended. This may be exceeded by 25% for peak conditions.

\* To convert feet of water to PSIG, use the following formula: ft H<sub>2</sub>O ÷ 2.307 = PSIG

## Chilled Water Performance Specifications 15.5°C (60°F) EWT

Temperature dry bulb (DB), wet bulb (WB) °C (°F)	CW Delta T °C (°F)	Total Net Capacity kW (BTU/hr)	Sensible Net Capacity kW (BTU/hr)	Sensible Heat Ratio SHR	CW Flow Rate l/s (GPM)	Total CW Pressure Drop kPa (ft H <sub>2</sub> O)*
<b>26.7°C DB, 17.1°C WB (80°F DB, 62.8°F WB)</b>						
	5.5 (10)	17.5 (60,000)	17.5 (60,000)	1.00	0.9 (13.5)	19 (6.2)
	6.6 (12)	15.2 (52,000)	15.2 (52,000)	1.00	0.6 (10.0)	11 (3.7)
	7.7 (14)	13.1 (45,000)	13.1 (45,000)	1.00	0.5 (7.6)	6 (2.1)
	8.8 (16)	11.1 (38,000)	11.1 (38,000)	1.00	0.4 (5.8)	4 (1.4)
	10 (18)	9.3 (32,000)	9.3 (32,000)	1.00	0.3 (4.5)	3 (0.9)
	11.1 (20)	7.7 (26,000)	7.7 (26,000)	1.00	0.2 (3.5)	2 (0.5)
<b>29.4°C DB, 18.1°C WB (85°F DB, 64.5°F WB)</b>						
	5.5 (10)	23.8 (81,000)	23.8 (81,000)	1.00	1.1 (17.7)	31 (10.4)
	6.6 (12)	21.1 (72,000)	21.1 (72,000)	1.00	0.8 (13.2)	18 (6.01)
	7.7 (14)	18.5 (63,000)	18.5 (63,000)	1.00	0.6 (10.1)	11 (3.7)
	8.8 (16)	16.1 (55,000)	16.1 (55,000)	1.00	0.5 (7.9)	7 (2.3)
<b>32.2°C DB, 18.9°C WB (90°F DB, 66.1°F WB)</b>						
	5.5 (10)	31.5 (108,000)	31.5 (108,000)	1.00	1.4 (22.8)	51 (17.1)
	6.6 (12)	28.3 (97,000)	28.3 (97,000)	1.00	1.1 (17.2)	30 (9.9)
<b>35.0°C DB, 19.8°C WB (95°F DB, 67.7°F WB)</b>						
	5.5 (10)	40.6 (139,000)	40.6 (139,000)	1.00	1.8 (28.7)	80 (26.8)

Note: All values are accurate to +/- 5% and based on full speed with standard filters

Note: Any CW flow rate of 0.19 l/s - 0.32 l/s (3.0 GPM - 5.0 GPM) may cause an increased error in flow rate and power calculation. A fluid flow fault may result. Any flow rate under 0.19 l/s (3.0 GPM) may also display as 0 in the flow rate and power calculation.

Note: For sustained operation, a maximum flow rate of 2.2 l/s (34 GPM) is recommended. This may be exceeded by 25% for peak conditions.

\* To convert feet of water to PSIG, use the following formula: ft H<sub>2</sub>O ÷ 2.307 = PSIG

## Chilled Water Data - General

MODEL	ACRP 500 Series
<b>MODULATING VALVES</b>	
Size -3 Way Ball Valve - NPT mm (in)	25.4 (1)
<b>AIR SYSTEM - FANS (Standard Filter Installed)</b>	
Air Volume - l/s (SCFM)	3162 (6700)
Fan Motor - W (HP)	1100 (1.5)
Number of Fans	3
<b>COOLING COIL - COPPER TUBE/ALUMINUM FIN</b>	
Face Area - m <sup>2</sup> (ft <sup>2</sup> )	0.74 (7.9)
Rows Deep	4
Fins per meter (Fins per inch)	468 (12)
<b>HUMIDIFICATION - SOLID STATE ELECTRODE CANISTER</b>	
Flush Cycle	Automatic
Capacity - kg/hr (lbs/hr)	3.0 (6.6)
kW	2.25
<b>REHEAT</b>	
Electric - Equally Loaded Three Stage, Finned Tubular, Low-Watt Density	
Capacity - kW (BTU/hr)	9.0 (30,700)
Stages	3
<b>FILTERS - PLEATED (STANDARD)</b>	
Quantity	4
Size - mm (in)	418 x 470 (16.45 x 18.5)
Depth - mm (in)	96 (3.78)
Efficiency (%)	30
<b>FILTERS - PLEATED (OPTIONAL)</b>	
Quantity	4
Size - mm (in)	418 x 470 (16.45 x 18.5)
Depth - mm (in)	96 (3.78)
Efficiency (%)	85
<b>PHYSICAL DATA</b>	
Weight - kg (lbs)	352 (776)
Height - mm (in)	1991 (78.40)
Width - mm (in)	600 (23.62)
Depth - mm (in)	1070 (42.13)
<b>CONNECTION SIZES</b>	
<b>Chilled Water</b>	
Supply Line - mm (in)	35.0 (1 3/8)
Return Line - mm (in)	35.0 (1 3/8)
<b>Humidifier</b>	
Supply Line - mm (in)	6.35 (1/4)
<b>Condensate Drain</b>	
Drain Line - mm (in)	12.7 (1/2)

For sustained operation, a maximum flow rate of 2.2 l/s (34 GPM) is recommended. This may be exceeded by 25% for peak conditions. Maximum working pressure for the unit is 300 psig (2068.4 kPa).

## Glycol Correction Factors

Performance Criteria	Glycol Solution	Percent Weight of Solution ***					
		0	10%	20%	30%	40%	50%
Capacity*	Ethylene	1.00	0.97	0.93	0.88	0.81	0.75
	Propylene	1.00	0.96	0.90	0.82	0.77	0.74
Pressure Drop**	Ethylene	1.00	1.04	1.13	1.21	1.31	1.41
	Propylene	1.00	1.09	1.20	1.35	1.52	1.67

All correction factors are based on unit entering conditions of 29.4°C (85°F) DB, 18.1 °C (64.5°F) WB, 1368.6 L/S (6950 CFM), 1.72 L/S (27.3 GPM), and 7.2°C (45°F) EFT.

\*Multiply capacity of device or system by factor above for % solution.

\*\*Multiply pressure drop of system by factor above for % solution.

\*\*\*Glycol concentrations over 50% are not recommended.

## Altitude Correction Factors for InRow Products

Room Condition: 72 DB/50% RH

Altitude - m (ft)	0	305 (1000)	610 (2000)	915 (3000)	1219 (4000)	1524 (5000)	1829 (6000)	2134 (7000)	2438 (8000)	2743 (9000)	3048 (10000)
Specific volume - cm <sup>3</sup> /g (ft <sup>3</sup> /lb)	847.77 (13.58)	879.61 (14.09)	912.70 (14.62)	947.66 (15.18)	983.86 (15.76)	1021.32 (16.36)	1061.28 (17.00)	1103.10 (17.67)	1146.80 (18.37)	1193.00 (19.11)	1241.69 (19.89)
Density - g/m <sup>3</sup> (lb/ft <sup>3</sup> )	1185.37 (0.074)	1137.31 (0.071)	1089.26 (0.068)	1057.22 (0.066)	1009.16 (0.063)	977.13 (0.061)	945.10 (0.059)	913.05 (0.057)	865.00 (0.054)	832.97 (0.052)	800.92 (0.050)
Density Ratio	1.000	0.964	0.929	0.895	0.862	0.830	0.799	0.769	0.739	0.711	0.683
Capacity Correction	1.000	0.981	0.962	0.933	0.913	0.884	0.865	0.846	0.826	0.807	0.787

Density ratio is used for air flow correction factor.

Capacity correction is used for performance derate.

## Air-cooled Performance Specifications

NET COOLING CAPACITY	
Entering Air Temperature	ACRP 100 Series
<b>22.2°C DB, 15.5°C WB (72°F DB, 60°F WB)</b>	
Total - kW (BTU/hr)	22.8 (78,000)
Sensible - kW (BTU/hr)	19.0 (65,000)
<b>23.9°C DB, 16.2°C WB (75°F DB, 61.1°F WB)</b>	
Total - kW (BTU/hr)	25.2 (86,000)
Sensible - kW (BTU/hr)	21.7 (74,000)
<b>26.7°C DB, 17.1°C WB (80°F DB, 62.8°F WB)</b>	
Total - kW (BTU/hr)	26.9 (92,000)
Sensible - kW (BTU/hr)	26.9 (92,000)
<b>29.4°C DB, 18.1°C WB (85°F DB, 64.6°F WB)</b>	
Total - kW (BTU/hr)	29.0 (99,000)
Sensible - kW (BTU/hr)	29.0 (99,000)
<b>32.2°C DB, 19.0°C WB (90°F DB, 66.2°F WB)</b>	
Total - kW (BTU/hr)	30.5 (104,000)
Sensible - kW (BTU/hr)	30.5 (104,000)
<b>35.0°C DB, 19.9°C WB (95°F DB, 67.8°F WB)</b>	
Total - kW (BTU/hr)	33.7 (115,000)
Sensible - kW (BTU/hr)	33.7 (115,000)
<b>37.8°C DB, 20.7°C WB (100°F DB, 69.3°F WB)</b>	
Total - kW (BTU/hr)	36.9 (126,000)
Sensible - kW (BTU/hr)	36.9 (126,000)
<b>40.6°C DB, 21.6°C WB (105°F DB, 70.8°F WB)*</b>	
Total - kW (BTU/hr)	36.6 (125,000)
Sensible - kW (BTU/hr)	36.6 (125,000)

\*Airflow reduced to 4000 SCFM at this condition to maintain adequate return gas temperature.

Note: Unit is not recommended for use with total loads of 10 kW or less.

Note: Shaded lines represent leaving air temperatures above ASHRAE specifications of 25°C (77° F) at maximum airflow.

## Air-cooled Data - General

MODEL	ACRP 100 Series
<b>AIR SYSTEM - FAN (Standard Filter Installed)</b>	
Air Volume - l/s (SCFM)	2265 (4800)
Fan Motor - W (HP)	1100 (1.5)
Number of Fans	2
<b>COOLING COIL - COPPER TUBE/ALUMINUM FIN</b>	
Face Area - m <sup>2</sup> (ft <sup>2</sup> )	.56 (6.0)
Rows Deep	4
<b>HUMIDIFICATION - SOLID STATE ELECTRODE CANISTER</b>	
Flush Cycle	automatic
Capacity - kg/hr (lbs/hr)	3 (6.6)
kW	2.25
<b>REHEAT</b>	
Electric - Equally Loaded Two Stage, Finned Tubular, Low-Watt Density	
Capacity - kW (BTU/hr)	6 (20,500)
Stages	2
<b>FILTERS - PLEATED (STANDARD)</b>	
Quantity	3
Size - mm (in)	418 x 470 (16.45 x 18.5)
Depth - mm (in)	96 (3.78)
Efficiency (%)	30
<b>FILTERS - PLEATED (OPTIONAL)</b>	
Quantity	3
Size - mm (in)	418 x 470 (16.45 x 18.5)
Depth - mm (in)	96 (3.78)
Efficiency (%)	85
<b>PHYSICAL DATA</b>	
Weight - kg (lbs)	378 (833)
Height - mm (in)	1991 (78.40)
Width - mm (in)	600 (23.62)
Depth - mm (in)	1070 (42.13)
<b>CONNECTION SIZES</b>	
Refrigerant	
Discharge	7/8 in ODF brazed
Maximum pressure drop - bar (PSI)	0.7 (10)
Liquid	7/8 in ODF brazed
Humidifier	
Supply Line - mm (in)	6.35 (1/4)
Condensate Drain	
Drain Line - mm (in)	12.7 (1/2)

## Sound Performance Data

Chilled Water Tested Sound Data										
Fan Speed%	Airflow m <sup>3</sup> /s (SCFM)	Sound Power dB at Frequency Hz re: 10 <sup>-12</sup> W								Lp Sound Pressure dB re: 20 microPa*
		125	250	500	1000	2000	4000	8000	dB A	dB A
35	1.13 (2500)	69.5	37.5	63.5	60.0	54.0	47.5	40.0	65.4	54.9
50	1.79 (3800)	84.0	79.0	75.5	69.5	67.5	58.5	53.5	76.9	66.8
70	2.55 (5400)	92.0	87.0	83.5	79.0	74.5	69.5	63.5	85.9	75.0
85	3.04 (6450)	92.0	95.0	89.0	84.5	79.0	74.5	69.0	90.6	80.7
100	3.26 (6900)	90.0	96.5	90.5	85.0	80.5	76.0	70.5	91.7	81.9

\*Weighted Sound Pressure dBA in a 232.2 m<sup>3</sup> (8200 ft<sup>3</sup>) room at 6 ft (1.8 m) distance.

Air-cooled Tested Sound Data										
Fan Speed%	Airflow m <sup>3</sup> /s (SCFM)	Sound Power dB at Frequency Hz re: 10 <sup>-12</sup> W								Lp Sound Pressure dB re: 20 microPa*
		125	250	500	1000	2000	4000	8000	dB A**	dB A
50	1.27 (2700)	84.5	87.5	78.0	77.5	75.0	66.5	65.5	83.4	72.8
75	1.79 (3800)	92.5	90.0	84.0	81.5	77.5	71.5	68.5	87.6	76.8
100	2.26 (4800)	90.0	98.0	91.0	85.0	81.0	76.5	72.0	92.3	82.8

\*Weighted Sound Pressure dBA in a 8200 ft<sup>3</sup> (232.2 m<sup>3</sup>) room at 6 ft (1.8 m) distance.

\*\*Based on compressor operating at full speed.



## Electrical Data

SKU	Voltage	MCA	MOP	LRA	RLA	FLA	Hz	Power (kW)
ACRP100	200 - 240	80.1	100	160*	50.0	N/A	50/60	19
ACRP101	460 - 480	39.9	50	139*	23.2	N/A	60	21
ACRP102	380 - 415	N/A	N/A	139*	23.2	32*	50	20
ACRP500	200 - 240	46.8	50	N/A	N/A	N/A	50/60	14
ACRP501	460 - 480	24.8	30	N/A	N/A	N/A	60	14
ACRP502	380 - 415	N/A	N/A	N/A	N/A	24**	50	15

Note: Above data is based on maximum operating condition

\*Local or national codes may require the installation of an external disconnect. The disconnect must be rated properly for the equipment.

\*\*Local or national codes may require the installation of external disconnects. Two disconnects would be required and must be rated properly for the equipment.

MCA - Minimum Circuit Ampacity

MOP - Maximum Overcurrent Protection

LRA - Locked Rotor Amps

RLA - Rated Load Amps

FLA - Full Load Amps

# Dimensional Data

## InRow RP Assembled Module

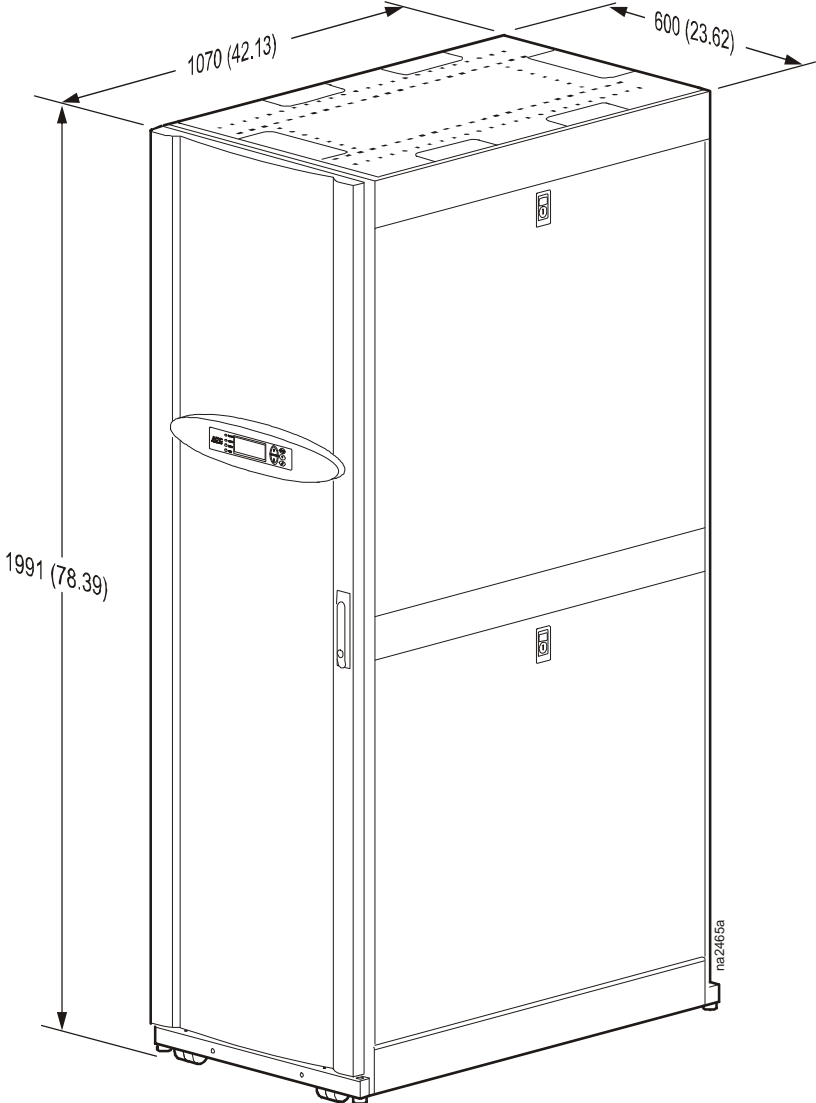

Dimensions are shown in mm (in).

**SX to VX Height Adapter**

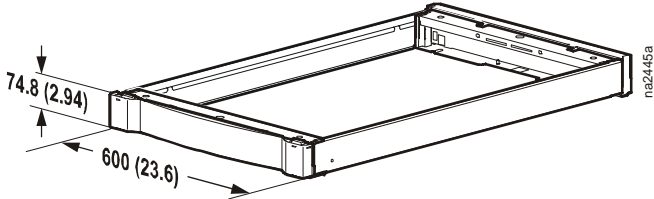

**SX to 48U SX Height Adapter**

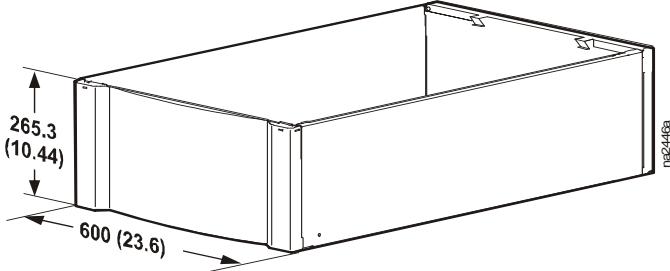



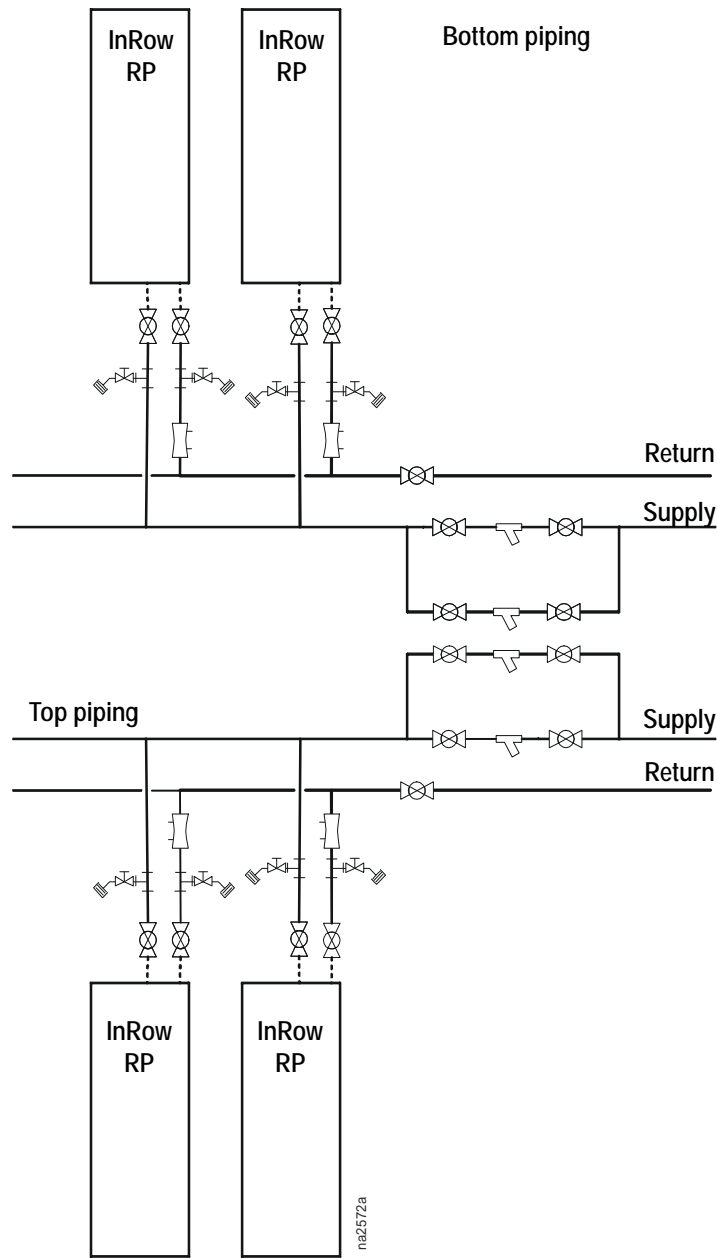

Dimensions are shown in mm (in).

# Piping and Mechanical Connections

## Chilled water piping diagram



- |   |   |   |                                  |
|---|---|---|----------------------------------|
| -----   | Flex hose or copper                               |  | Circuit setter (field-installed) |
| —————   | Copper tubing                                     |  | Hose end drain with cap          |
|  | Y-strainer with 20 mesh screen (field installed)* |  | Isolation valve                  |

\*Blow down may be installed on Y-strainer.



**Note:** Top or bottom entry can be chosen individually for each type of connection, i.e. power, condensate drain, humidifier water supply, chilled water supply and chilled water return. Top piping configuration will have the same valves and strainers as bottom piping configuration.

### Top chilled water piping access (top view)

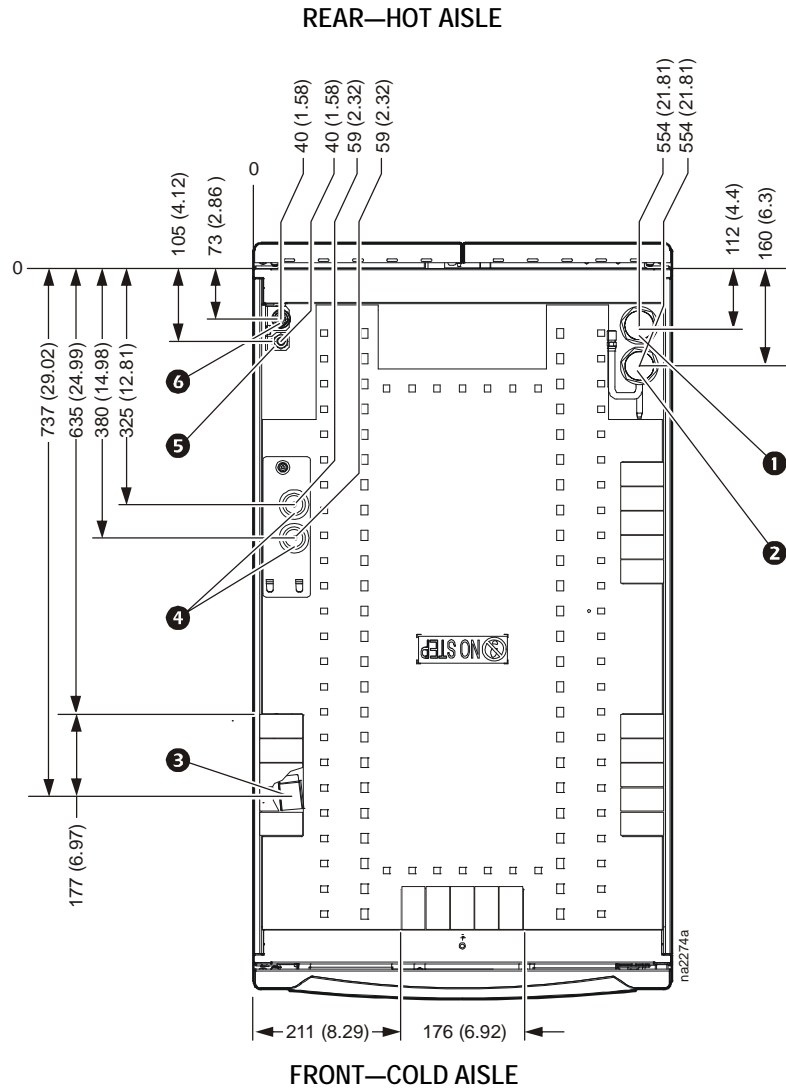

Dimensions are shown in mm (in).

- ❶ Chilled water supply
- ❷ Chilled water return
- ❸ Trough for communication cables
- ❹ Power connections—dual feed
- ❺ Humidifier supply
- ❻ Condensate drain

# Bottom chilled water piping access (bottom view, looking up)

REAR—HOT AISLE

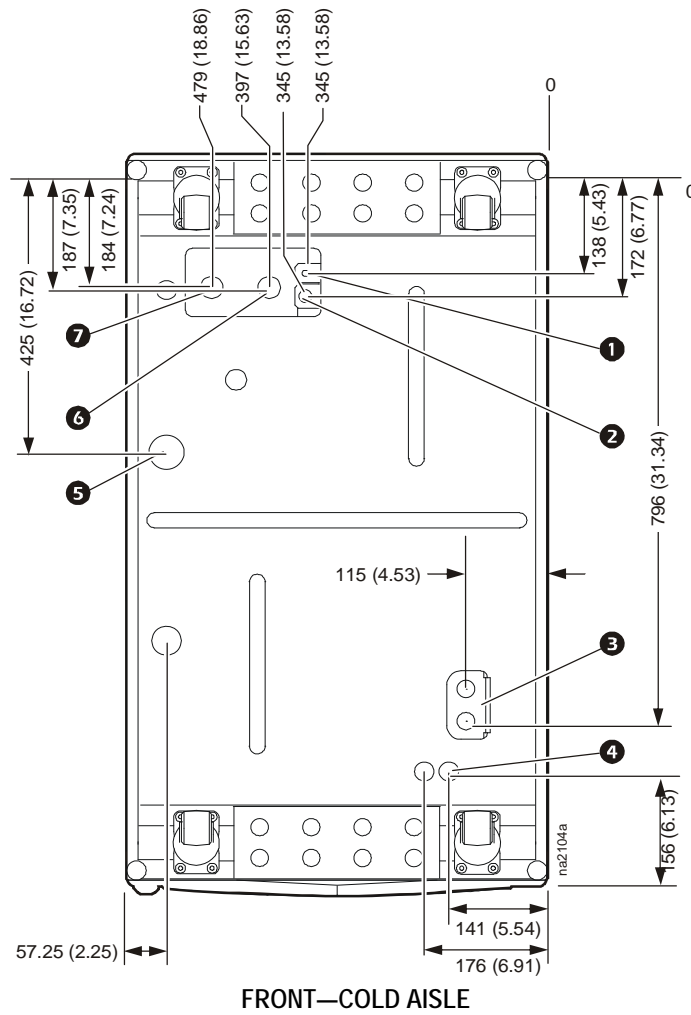

FRONT—COLD AISLE

Dimensions are shown in mm (in).

- ① Humidifier supply
- ② Condensate drain
- ③ Power connections—dual feed
- ④ Communication connections—27.80 mm (1.09 in)
- ⑤ Condensate overflow
- ⑥ Chilled water supply
- ⑦ Chilled water return

# Air-cooled piping diagram

Bottom piping

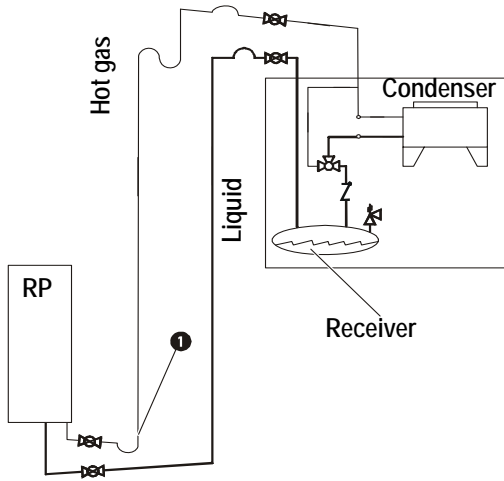

Top piping

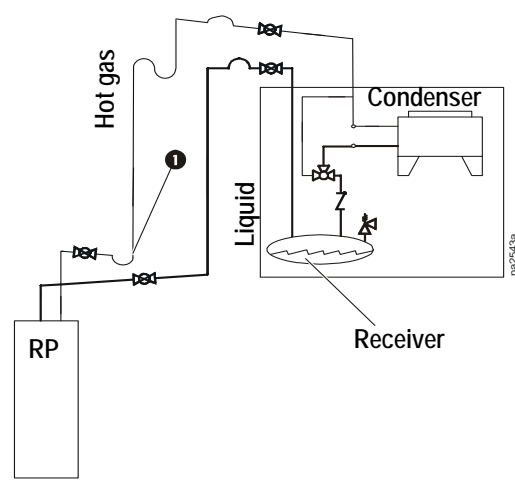

**Note:** Shutoff valves shown nearest to the condensers are not supplied by APC.

- |          |   |  |                       |
|----------|---|--|-----------------------|
| <b>1</b> | Pitch in direction of refrigerant flow; 4 mm per m (0.5-in per 10 ft) |  | Pressure relief valve |
|          | Shutoff valves  |  | P-trap                |
|          | Head pressure control valve   |  | S-trap                |
|          | Check valve   |  | Inverted P-trap       |

All lines are Type L copper tubing.



**Note:** Route piping through the top or bottom of the InRow RP.

**Note:** Trap the vertical discharge line every 6 m (20 ft) to ensure proper oil return.

**Note:** The maximum piping run is 61 m (200 ft) equivalent length. Size the piping pursuant to accepted refrigeration practice.



**Warning:** Do not install the air-cooled condenser below the indoor equipment. The condenser must be positioned above or at the same level as the equipment to ensure proper function.

## Air-cooled piping access (top)

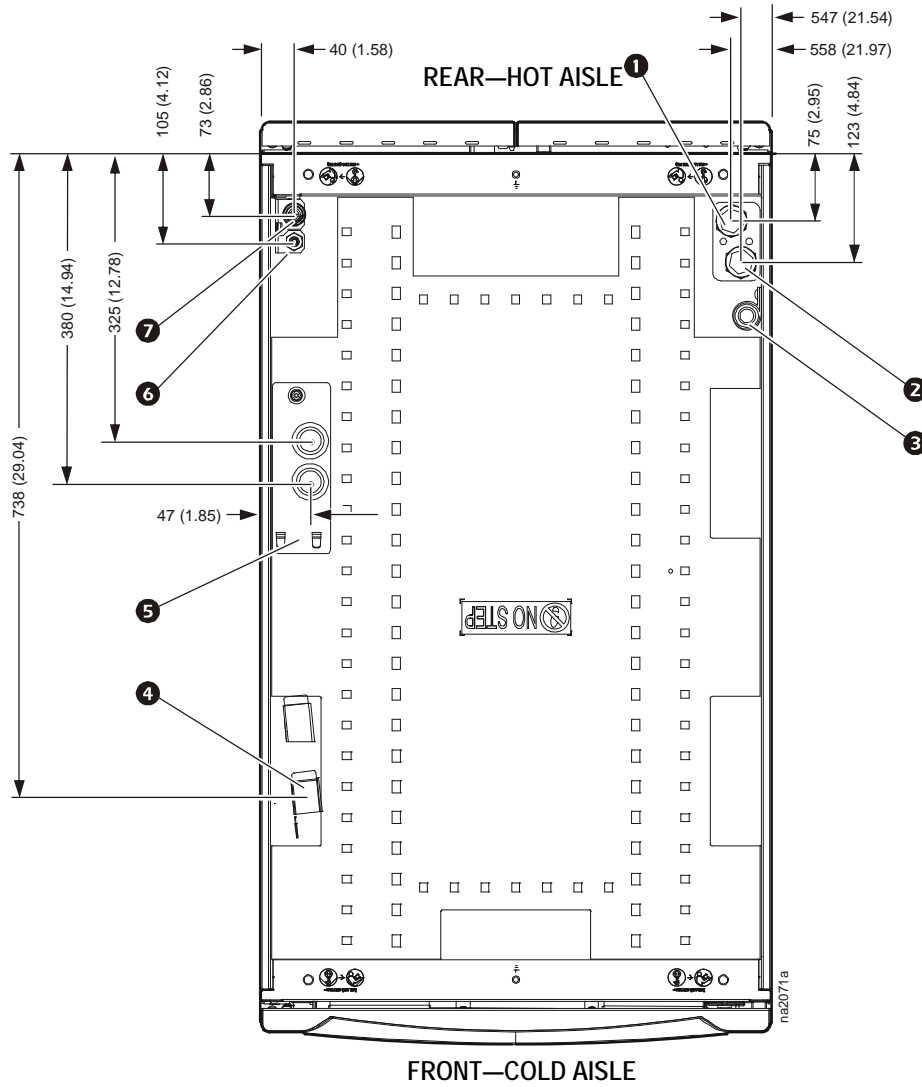

- ❶ Refrigerant discharge line
- ❷ Refrigerant liquid line
- ❸ Pressure relief valve discharge line
- ❹ Trough for communication cables
- ❺ Power connections
- ❻ Humidifier water supply
- ❼ Condensate drain

Dimensions are shown in mm (in).



## Air-cooled piping access (bottom view, looking up)

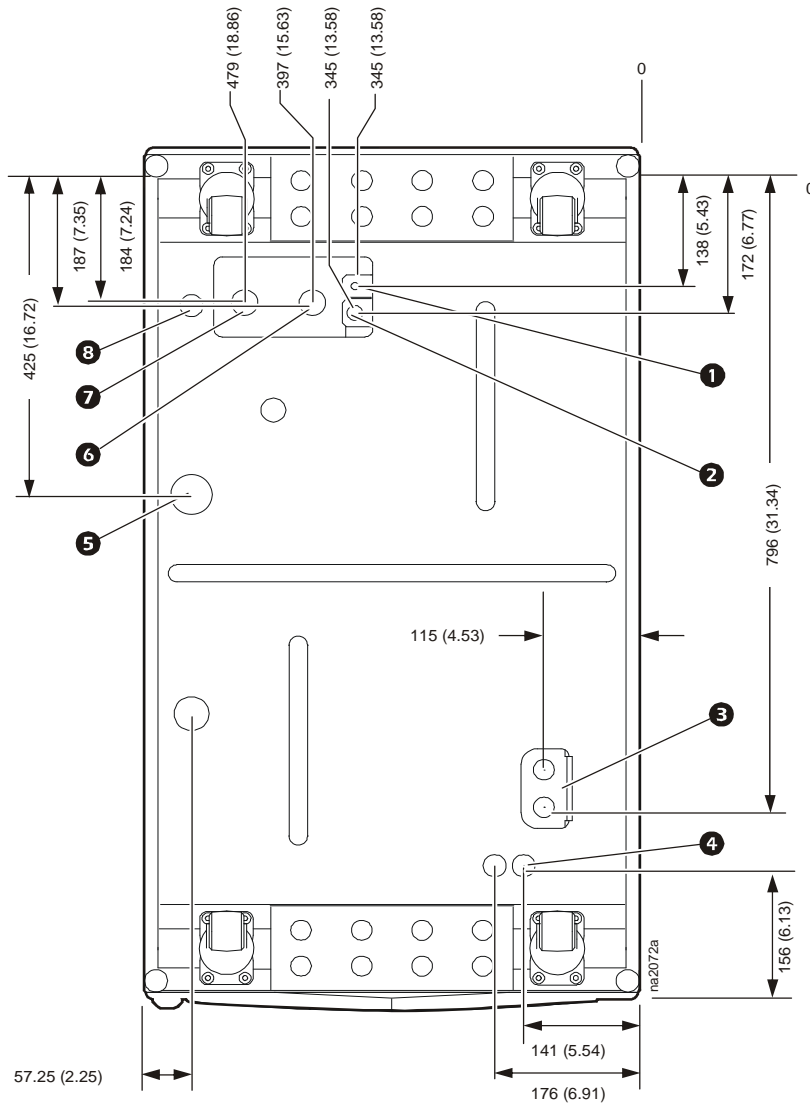

- ❶ Humidifier water supply
- ❷ Condensate drain
- ❸ Power connections
- ❹ Communication connections—27.80 mm (1.09 in)
- ❺ Condensate overflow—50.00 mm (1.97 in)
- ❻ Refrigerant discharge line
- ❼ Refrigerant liquid line

Dimensions are shown in mm (in).

# Air-Cooled Condensers

## Mechanical Data

SKU	Ambient Temp	Sound Pressure (dbA) at 10 ft and 100% Fan Speed	Sounds Pressure (dbA) at 10 ft set area level, and Max Compressor Speed Selected Ambient Temp	Air Quantity	Fan	Unit	Connection Size		Weight	Capacity	
				l/s (CFM)	Qty.	kW	Hot Gas	Liquid	Kg (Lbs)	MBH/1F TD	kW/1C TD
ACCD75201	95 (35)	67	62	4955 (10500)	1	2.2	1 3/8 in	1 3/8 in	163 (360)	8.8	4.6
ACCD75202	105 (40)	70	65	10383 (22000)	2	4.4	1 5/8 in	1 5/8 in	290 (640)	14.6	7.7
ACCD75203	115 (46)	72	68	14819 (31400)	3	6.6	2 1/8 in	2 1/8 in	458 (1010)	25.8	13.6
ACCD75204	95 (35)	67	62	4955 (10500)	1	2.2	1 3/8 in	1 3/8 in	163 (360)	8.8	4.6
ACCD75205	105 (40)	70	65	10383 (22000)	2	4.4	1 5/8 in	1 5/8 in	290 (640)	14.6	7.7
ACCD75206	115 (46)	72	68	14819 (31400)	3	6.6	2 1/8 in	2 1/8 in	458 (1010)	25.8	13.6
ACCD75207	95 (35)	54	51	5711 (12100)	1	2.2	42 mm	22 mm	173 (381)	17.6	9.3
ACCD75208	105 (40)	57	54	11940 (25300)	2	2.2	42 mm	28 mm	307 (677)	27.1	14.3
ACCD75209	115 (46)	57	55	11374 (24100)	2	4.4	54 mm	35 mm	360 (792)	48.2	25.4

Specifications given for conditions at sea level.

## Electrical Data

SKU	Voltage	FLA	MCA	MOP
ACCD75201	208-230 3 ph 60 Hz	7.0	15.0	25
ACCD75202	208-230 3 ph 60 Hz	14.0	20.0	35
ACCD75203	208-230 3 ph 60 Hz	21.0	22.8	40
ACCD75204	460 3 ph 60 Hz	3.5	15.0	15
ACCD75205	460 3 ph 60 Hz	7.0	15.0	15
ACCD75206	460 3 ph 60 Hz	10.5	15.0	20
ACCD75207	400 3 ph 50 Hz	3.7	N/A	N/A
ACCD75208	400 3 ph 50 Hz	7.4	N/A	N/A
ACCD75209	400 3 ph 50 Hz	7.4	N/A	N/A

FLA = Full Load Amps  
MCA = Minimum Circuit Amperes  
MOP = Maximum Overcurrent Protection

### ACCD75201 and ACCD75204

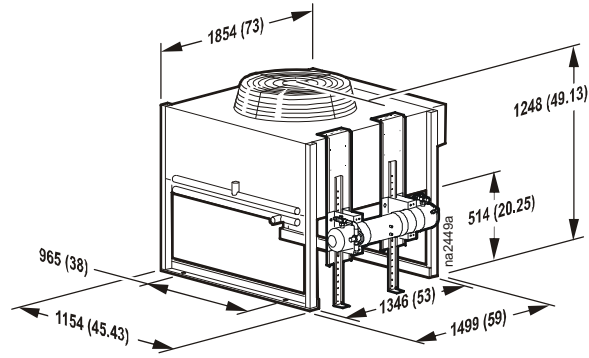

### ACCD75202 and ACCD75205

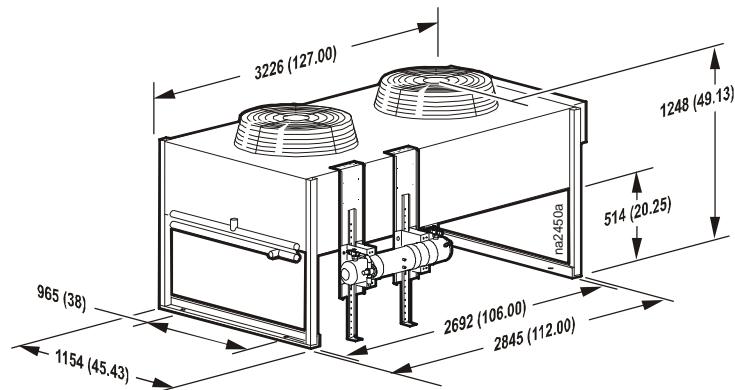

### ACCD75203 and ACCD75206

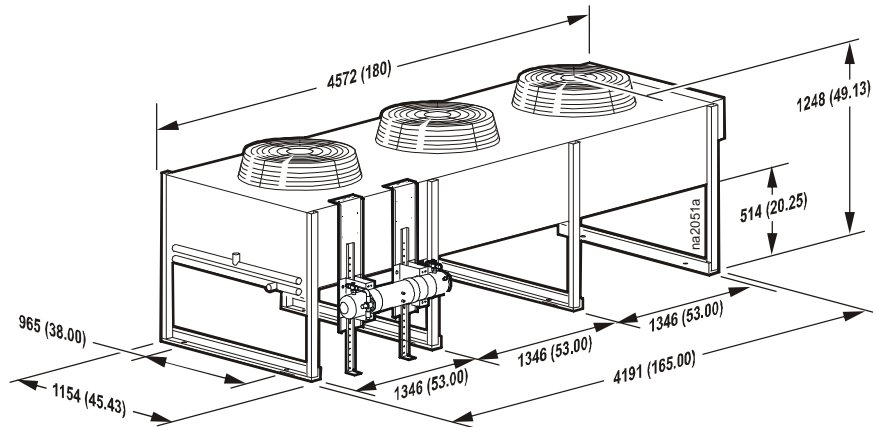

Dimensions are shown in mm (in).

All condensers shown on this page have eight 22 mm (0.875 in) mounting holes on their lower rails.

## ACCD75207

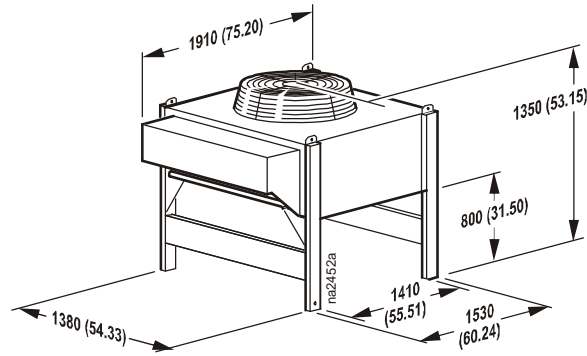

## ACCD75208 and ACCD75209

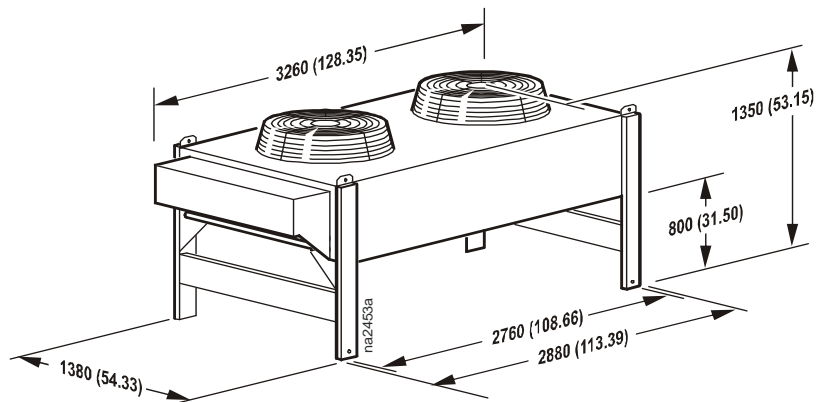

Dimensions are shown in mm (in).

All condensers shown on this page have 16 mm (0.63 in) mounting holes on each of their lower legs.

### Air-cooled Condenser Features

Available in one to three fan configurations, APC offers air-cooled condensers with a vertical air discharge pattern. These condensers utilize variable speed EC motor technology for improved sound and energy performance.

60 Hz specific features:

- Constructed with aluminum housing
- Weatherproof control panel with a factory mounted door interrupt disconnect switch

50 Hz specific features:

- Constructed with painted galvanized steel



**Note:** A disconnect should be field-supplied based on MOP numbers.

# Guide Specifications

---

## PART 1 — GENERAL

### 1.01 SUMMARY

- A. The environmental control system shall be designed specifically for precision temperature and humidity control applications. It will automatically monitor and control heating, cooling, humidifying, dehumidifying, and filtering functions for the conditioned space. The system shall be built to the highest quality engineering and manufacturing standards, and shall be floor mounted and configured for horizontal airflow, with draw-through air pattern, to provide uniform air distribution over the entire face of the coil.

### 1.02 DESIGN REQUIREMENTS

- A. The system shall be as described in the following specification as manufactured by APC.
  1. Model: \_\_\_\_\_.
  2. Total net cooling capacity: \_\_\_\_\_ kW (MBH).
  3. Sensible net cooling capacity: \_\_\_\_\_ kW (MBH).
  4. Return air dry bulb temperature: \_\_\_\_\_ °C (°F) DB.
  5. Return air wet bulb temperature: \_\_\_\_\_ °C (°F) WB.
  6. Humidity: \_\_\_\_\_ % RH.
  7. Air Volume: \_\_\_\_\_ L/s (CFM).
  8. Humidifier capacity: \_\_\_\_\_ kg/hr (lbs/hr).
  9. Electrical supply: \_\_\_\_\_ V, \_\_\_\_\_ Hz.

### 1.03 SUBMITTALS

- A. Submittals shall be provided with the proposal and shall include: capacity data, electrical data, physical data, electrical connection drawing, and piping connection drawing.

### 1.04 QUALITY ASSURANCE

- A. The system shall be factory-tested prior to shipment. Testing shall include, but not be limited to: complete pressure and leak testing to ensure system integrity, “Hi-Pot” test, and controls calibration and settings. The system shall be NRTL listed, MCA, and electrical system shall be UL Listed to UL 1995 and CSA 22.2 No. 236.

### 1.05 WARRANTY

- A. System parts shall be warranted for a period of 18 months from date of shipment and 12 months from startup.

## **PART 2 — PRODUCT**

### **2.01 STANDARD COMPONENTS**

#### **A. CABINET CONSTRUCTION**

1. Exterior panels shall be 1.2 mm (18 gauge) steel. Front and rear exterior panels shall be 1.2 mm (18 gauge) perforated steel with 69.5% open free area, and equipped with a keyed lock to provide a means of securing access to the internal components of the unit.
2. The frame shall be constructed of 1.5 mm (16 gauge) formed steel welded for maximum strength. All units shall provide maintenance from the front and rear, allowing units to be placed within a row of racks.
3. All exterior panels and frame shall be powder coated for durability and attractive finish. Exterior frame and panel color shall have color values: L = 74.50, a = -.53, b = +8.20.
4. Units shall include casters and leveling feet to allow ease of installation in the row and provide a means to level the equipment with adjacent IT racks.

#### **B. VARIABLE SPEED FAN ASSEMBLY**

1. Variable Speed Fans: The unit is equipped with variable speed, electronically commutated, 400-mm backward incline fans complete with Inlet Volute.
2. Fan Protection: discharge finger guard. Outlet of the fan should include a cage type finger guard.

#### **C. AUTOMATIC TRANSFER SWITCH (CHILLED WATER ONLY)**

The unit shall be equipped with an automatic transfer switch (ATS). The ATS shall automatically switch from a main power supply to a secondary power supply in the event of a power outage without change in equipment operation. The ATS shall monitor the main power supply so that when the power is restored to the primary source it will automatically switch from the secondary source back to the main power source.

#### D. MAIN DISCONNECT SWITCH

1. Unit shall be provided with Thermal-Magnetic circuit breakers with interrupt capacity ratings per UL489/CSA C22.2/IEC-947.

Voltage	kAIC
200-240V 50/60Hz	50
380-415V 50Hz	36
460-480V 60Hz	22

2. Chilled Water: Units shall include main disconnect switches located on the E-panel in order to individually disconnect dual A-B power inputs.
3. Air-cooled: Units shall include a main disconnect switch located on the E-panel in order to disconnect power input.
4. A condenser disconnect shall be field-supplied.

#### E. MICROPROCESSOR CONTROLLER

1. Monitoring and Configuration: The display shall allow monitoring and configuration of the air conditioning unit through a menu-based control. Functions include status reporting, set-up, and temperature set points. Four LEDs report the operational status of the connected air conditioning unit.
2. Controls: The microprocessor controller shall come equipped with control keys to allow the user to navigate between menus, select items, and input alpha numeric information.
3. Alarms: The microprocessor controller shall activate a visible and audible alarm in the occurrence of the following events:
  - a. Cool Fail
  - b. Rack inlet temperature violation
  - c. Rack inlet temperature sensor fault
  - d. Air filter clogged
  - e. Air filter run hours exceeded
  - f. Filter DP sensor failure
  - g. Supply air sensor fault
  - h. Return air sensor fault
  - i. Supply air high temperature violation
  - j. Return air high temperature violation
  - k. Fan fault
  - l. Fan run hours exceeded
  - m. Water detection fault
  - n. Condensate pump fault
  - o. Condensate run hours exceeded
  - p. Humidifier water conductivity high violation
  - q. Humidifier fault tolerance exceeded
  - r. Humidifier low water

- s. Humidifier excessive output reduction
- t. Humidifier drain fault
- u. Humidifier cylinder full
- v. Humidifier replace cylinder
- w. Humidifier RS485 communication fault
- x. Humidifier run hours violation
- y. Humidity high/low violation
- z. Supply humidity sensor fault
- aa. Return humidity sensor fault
- ab. Heater fault
- ac. Heater run hours exceeded
- ad. Heater interlock shutdown
- ae. Group communication fault
- af. Internal communication fault
- ag. A-link isolation relay fault
- ah. External communication fault
- ai. Input contact fault
- aj. Invalid supply setpoint
- ak. Idle mode active
- al. Coil fluid valve actuator fault
- am. Fluid flow fault
- an. Entering fluid temperature high violation
- ao. Entering fluid temperature sensor fault
- ap. Leaving fluid temperature sensor fault
- aq. Power source failure
- ar. Fluid calibration
- as. High discharge pressure
- at. Low suction pressure
- au. High suction pressure
- av. Compressor drive failure
- aw. Compressor drive warning
- ax. Compressor run hours violation
- ay. Compressor drive RS485 communication fault
- az. Excessive compressor cycling
- ba. Air flow decreased while compressor off
- bb. Suction pressure sensor failure
- bc. Discharge pressure sensor failure
- bd. High pressure switch active
- be. Fan speed decreased to avoid high pressure (event only)
- bf. Compressor speed decreased to avoid high pressure (event only)
- bg. Compressor high pressure
- bh. Oil return pump active



4. Logging: The microprocessor controller shall log and display all available events. Each alarm log shall contain time/date stamp as well as operating conditions at the time of occurrence. Controller shall display the run time hours for major components.

#### F. NETWORK MANAGEMENT CARD

The unit shall include a network management card to provide management through a computer network through TCP/IP. Management through the network should include the ability to change set points as well as view and clear alarms.

#### G. COOLING COIL AND CONDENSATE PAN

1. Chilled Water: Cooling coil shall use raised lance type corrugated aluminum fin and (12.7 mm (1/2 in) OD copper tube coils. Fin shall be a minimum of 0.0055 in thick. Tube wall shall be a minimum of 0.016 in thick. Coil tube sheets shall be a minimum 1.2 mm (18 gauge) G90 galvanized steel. Coil shall be rated for a maximum pressure of 2757.9 kPa (400 psig). Coil headers are equipped with drip plates in the bottom to route the condensate accumulating on the header tubes to the condensation pan. Coil is configured in a counterflow arrangement to optimize heat transfer efficiency.
2. Direct Expansion: Cooling coil shall use raised lance type corrugated aluminum fin and 12.7 mm (1/2 in) OD copper tube coils. Fin shall be a minimum of 0.0055 in thick. Tube wall shall be a minimum of 0.016 in thick. Coil end supports shall be a minimum 1.2 mm (18 gauge) G90 galvanized steel. Coil shall be rated for a maximum pressure of 3447.3 kPa (500 psig), and the coils are certified in accordance with UL207. Coil header is equipped with a drip plate in the bottom to capture and direct the condensation accumulating on the suction header tube to the drain pan. Coil has 6 circuits complete with brass distributor and copper distribution tubes.

#### H. VARIABLE SPEED COMPRESSOR / VFD ASSEMBLY (AIR-COOLED ONLY)

1. Compressor: The unit shall be configured with a variable speed reciprocating hermetic compressor using a matched VFD. As a result, the compressor speed can be varied through a range between 30 and 85 Hz to accommodate varying load conditions. VFD firmware is written to include oil return protection in cases where pipe velocities may drop to low speeds during low loading periods.
2. Compressor is electrically protected through the VFD.
3. Compressor utilizes a noise cap for noise reduction.
4. Sight glass provided for air cooled system oil charging.

#### I. 3-WAY MODULATING VALVE (CHILLED WATER ONLY)

1. A floating point valve shall be microprocessor controlled to automatically direct the proper amount of chilled water in the cooling coil to maintain desired conditions. A shut-off valve located in the bypass line may be manually adjusted for 2-way flow if so desired.
2. Three way control valve shall be rated for 300 WOG with brass body and stainless steel ball.
3. Valve Actuator: Actuator shall be direct connect rotary floating point style actuator with potentiometer feedback, and should be capable of being replaced without disconnecting piping from the valve. Ability for manual operation is also provided.

#### J. CONDENSATE PUMP

Factory installed and wired condensate pump shall pump at 31.99 l/h (8.45 GPH) at 3.5 m (11.5 ft) of head. Pump shall have a dual position internal float and a reservoir made of polymeric materials to prevent corrosion.

#### K. FILTERS

1. The standard filters shall be 30% efficient per ASHRAE Standard 52.1, UL Class 2 (MERV 8 per ASHRAE 52.2). Filters shall be EN779 G4 efficient. The 96 mm (3.75 in) deep, pleated filters shall be replaceable from the rear of the unit.
2. The optional filter shall be 85% efficient per ASHRAE Standard 52.1 (MERV 13 per ASHRAE 52.2, EN779 F7).

## L. HUMIDIFIER

Humidifier shall be able to modulate capacity. The humidifier shall be self-contained, steam-generating type, factory piped and wired, with disposable cylinder and automatic solid-state control circuit. Humidifier canisters shall be replaceable. The humidifier controller shall communicate directly to the microprocessor controller and provide complete status and control at the operator interface. Humidifier shall control flush cycling and conductivity via automated controls. Humidifier shall be capable of producing up to 3 kg (6.6 lb) of steam per hour.

## M. ELECTRIC REHEAT

1. Reheat elements shall be low watt density, wired for three-phase, loaded equally on all three phases and shall be electrically and thermally protected by both automatic and manual reset cutouts. Reheat capacity shall be 9 kW for chilled water and 6 kW for air-cooled.
2. Reheat coils shall be stainless steel, fin tubular construction. Heater casing shall be 0.9 mm (20 gauge) G90 galvanized steel.
3. Heater shall be provided with self-engaging electrical connectors upon installation. Heater with manually connected conductors are not acceptable.

## N. TEMPERATURE AND HUMIDITY SENSORS

1. Internal Temperature Sensors: Thermister temperature sensors shall be mounted behind the front and rear doors to provide control inputs based on supply and return air temperature. Sensor accuracy shall be within +/- 1 degree F accuracy.
2. Remote Temperature Sensors: Three remote rack inlet temperature sensors shall be shipped with the unit to provide control input based on rack inlet temperature.
3. Internal Humidity Sensors: Humidity sensors shall be mounted behind both the front and rear doors and shall provide control input based on humidity in supply air. Humidifier sensor shall be +/- 3% RH accuracy full scale.
4. Water Temperature Sensors: Internal supply and return chilled water temperature sensors shall be installed into sealed wells. Wells are filled with thermal conducting heat transfer grease to provide accurate temperature sensors.

## O. SELECTABLE TOP OR BOTTOM PIPING (CHILLED WATER ONLY)

1. Pipe connections: The unit equipped with field connection from either the top or bottom of the unit. Unit connections shall be made internal to the unit.
2. Pipe adapter: The unit shall include two pipe adapters that convert a 31.75 mm (1 1/4 in) NPT to a 31.75 mm (1 1/4 in) BSPT (manufactured in accordance with BS21). Pipe adapters shall ship loose with the unit for field installation where applicable.

#### P. SELECTABLE TOP OR BOTTOM PIPING (AIR-COOLED ONLY)

1. Pipe connections: The unit is equipped with field connection from either top or bottom of the unit. Unit connections shall be made internal to the unit.
2. Pipe adapters: The unit shall include 1-in Rotolock to sweat adapters and associated Teflon seals.

#### Q. FLOW METER

1. Flow meter shall be factory piped inside the unit and connected to microprocessor controls to provide water flow rate through the unit. The microprocessor controller shall also use this information to provide total unit capacity out of the unit while in operation.
2. Flow meter shall be stainless steel construction turbine type meter, compatible with glycol/water solutions up to 50%, with accuracy of 1.5% or better on range 5-50 GPM.

#### R. CABLE WATER DETECTOR (OPTIONAL)

1. The optional leak detection sensing cable shall be shipped loose with the unit. If water or other conductive liquids contact the cable anywhere along its length, the main controller visually and audibly annunciates the leak.
2. The optional detector shall be provided with a 6.1 m (20 ft) of cable. Cable may be cascaded up to 24.4 m (80 ft).

#### S. BRIDGE POWER CABLE TROUGH

1. An overhead power distribution bridge, that sits between adjacent NetShelter racks and allows for removal of the unit without disrupting the overhead power cabling, is available as an accessory.
2. Cable trough shall be constructed of 1.5 mm (16 gauge) cold rolled steel with a black powder coat finish.

#### T. BRIDGE DATA PARTITION

1. An overhead cable distribution, that sits between adjacent Netshelter racks and allows for removal of the unit without disrupting overhead cabling, is available as an accessory.
2. Data partition shall be constructed of 1.5 mm (16 gauge) cold rolled steel with a black powder coat finish.

#### U. COOLING FLUIDS

Chilled Water and solutions of propylene or ethylene glycol up to 50% may be used. Solutions of brine or other aqueous salt are NOT permitted.

#### V. FREEZE PROTECTION

Per ASHRAE Handbook Fundamentals 2001 21.5, a maximum of 30% ethylene glycol and 35% propylene glycol are needed for freeze protection. Please consult ASHRAE handbook for more details.

# Guidelines for Installation

---

The InRow RP provides reliable, accurate temperature control of computer rooms, laboratories, and other environments that require close tolerance control. The unit incorporates the latest system design innovations to provide you with optimum efficiency, reliability, and accuracy of control.

The InRow RP unit will provide years of trouble-free service when installed and maintained by technically qualified personnel. For more detailed information, see the InRow RP Installation manual (990-2696 air-cooled and 990-2710 chilled water).

## Room preparation

During the design of the room, consideration should be given to the following factors: ease of entry for the system, floor-loading factors, and accessibility of piping and wiring.

The room must be sealed with a vapor barrier to minimize moisture infiltration. Polyethylene film (plastic sheeting) is a good vapor barrier for ceiling and wall applications. Rubber- or plastic-based paints should be applied to concrete floors and walls. The room should be thoroughly insulated to minimize thermal loads and make-up air (if required) should be preconditioned to reduce additional temperature, filtration, and moisture loads.

## Service access

At least 36 in (914.4 mm) of clear space must be left in the front and rear of the unit for routine service. In order to service the unit outside of the row, an area of 1219.2 mm (48 in) of clear space is required in the front and rear of the unit while it is in the row.

## Receiving the unit

Your InRow RP unit has been tested and inspected prior to shipment. To ensure that you have received the unit in excellent condition, perform a careful inspection of the crating and the unit immediately upon receipt. Verify that all parts ordered were received as specified and that the unit is the correct size and voltage necessary to fulfill your environmental control needs. Report any damage discovered to the freight carrier. If necessary, contact the APC field service department for help in repairing or replacing damaged parts. While APC is not responsible for damage incurred in transit, we want to make sure that you have no undue delays in your system start-up. Please refer to the unpacking sheet for more information.

## Rigging

The unit is manufactured with a formed steel frame for maximum strength and unit integrity. However, as with all electrical and mechanical equipment, you must take care with proper rigging of your unit.

When using a forklift to move the unit, use the shipping skid to protect the bottom of the unit. When using chains, cables, or rope to lift the unit, use spreader bars to prevent damage to the finished panels. Four threaded M10X16 holes are provided in the top of the frame to accommodate lifting eye bolts that can be utilized to lift the unit.

## Condensate Drain

Condensation from the evaporator pan is collected and discharged by the condensate pump to a 3/8 in (10 mm) I.D. condensate line supplied with the unit. Additional condensate piping is required to route to building condensate system.

**NOTE:** Because of an ongoing program dedicated to product improvement, specifications are subject to revisions without notice. APC assumes no responsibility, and disclaims all liability for damages resulting from use of this information or for any errors or omissions.





# APC Worldwide Customer Support

Customer support for this or any other APC product is available at no charge in any of the following ways:

- Visit the APC Web site to access documents in the APC Knowledge Base and to submit customer support requests.
  - **www.apc.com** (Corporate Headquarters)  
Connect to localized APC Web sites for specific countries, each of which provides customer support information.
  - **www.apc.com/support/**  
Global support searching APC Knowledge Base and using e-support.
- Contact an APC Customer Support center by telephone or e-mail.
  - Regional centers

Direct InfraStruXure Customer Support Line	(1)(877)537-0607 (toll free)
APC headquarters U.S., Canada	(1)(800)800-4272 (toll free)
Latin America	(1)(401)789-5735 (USA)
Europe, Middle East, Africa	(353)(91)702000 (Ireland)
Western Europe (inc. Scandinavia)	+800 0272 0272
Japan	(0) 36402-2001
Australia, New Zealand, South Pacific area	(61) (2) 9955 9366 (Australia)

- Local, country-specific centers: go to **www.apc.com/support/contact** for contact information.

Contact the APC representative or other distributor from whom you purchased your APC product for information on how to obtain local customer support.

Entire contents copyright 2008 American Power Conversion Corporation. All rights reserved. Reproduction in whole or in part without permission is prohibited. APC, the APC logo, and NetShelter are trademarks of American Power Conversion Corporation. All other trademarks, product names, and corporate names are the property of their respective owners and are used for informational purposes only.

