

## T7200D,E, T7300D,E,F and Q7300 Series 2000 Programmable Commercial Thermostats and Subbases

### PRODUCT DATA



- Automatic or manual changeover models available.
- Universal Versaguard™ Thermostat guards available.
- Convenient overrides allow temporary setpoint changes.
- Keypad lockout available.

#### T7200D,E Thermostats

- Use on single-stage conventional (T7200D) or heat pump (T7200E) applications.

#### T7300D,E Thermostats:

- Use on multistage conventional (T7300D) or heat pump (T7300E) applications.
- Models available with remote sensor capability.

#### T7300F Thermostats:

- Use on single-stage or multistage system in conventional or heat pump applications.
- Auxiliary contacts on Q7300 can be used to interface with C7400/W7459 Economizer System for total integration of rooftop control.
- Remote temperature sensors available for use with all models.
- Different levels of keypad lockout available.

#### Q7300 Subbase:

- Use with T7300D,E,F Thermostats.
- Auxiliary contacts can be used to interface with C7400/W7459 Economizer System for total integration of rooftop control.
- When used with the T7300F (revision 3 or later), the Q7300H communicates with other network devices.

## APPLICATION

The T7200, T7300 Thermostats and Q7300 Subbases control 24 Vac commercial single zone heating, ventilating and air conditioning (HVAC) equipment. In addition, the Q7300H Communicating Subbase can communicate schedule information and system instructions to other devices in a LonWorks® network.

## FEATURES

#### All Models:

- 7-day programming.
- Two Occupied and two Unoccupied periods per day.
- Individual heat and cool setpoints available for Occupied and Unoccupied periods.
- Proportional plus Integral (P+I) control eliminates temperature fluctuations.
- Intelligent Recovery® control automatically optimizes equipment start times based on building load.
- Intelligent Fan™ feature energizes fan continuously in the Occupied periods. Fan can also be configured for conventional heat or electric heat fan operation.

## Contents

Application .....	1
Features .....	1
Specifications .....	2
Ordering Information .....	2
Installation .....	5
Wiring Subbase or Wallplate .....	7
Settings .....	9
Installer Setup .....	10
Installer System Test .....	14
Programming .....	16
Operation .....	20
General Operation Information .....	22
Troubleshooting Guide .....	23
Cross Reference .....	25
Wiring Diagrams .....	33



## SPECIFICATIONS

### IMPORTANT

The specifications given in this publication do not include normal manufacturing tolerances. Therefore, this unit might not exactly match the listed specifications. This product is tested and calibrated under closely controlled conditions, and some minor differences in performance can be expected if those conditions are changed.

### T7200/T7300 Thermostats:

T7200 and T7300 Thermostats provide features listed in Table 1.

### Q7300 Subbases:

Q7300 Subbases provide features listed in Table 2.

**Table 1. T7200 and T7300 Thermostat Features.**

Model	Applications	Subbase Required	Maximum Stages		Changeover <sup>b</sup>	Hookup Drawing No.
			Heat	Cool		
T7200D	Conventional	None <sup>a</sup>	1	1	Automatic or Manual	19
T7200E	Heat Pump	None <sup>a</sup>	1	1		20
T7300D	Conventional	Q7300A, G, L	3	3		21-22, 27, 33-34
T7300E	Heat Pump	Q7300C, D	3	2		23-26
T7300F	Conventional or Heat Pump	Q7300A, C, D, G, L	3	3		21-27, 33-34
T7300F		Q7300H	—	—		28-31

<sup>a</sup> Wallplate provided.

<sup>b</sup> Configured in Installer Setup.

**Table 2. Q7300 Subbase Features.**

Model	Applications	Thermostat Required	Maximum Stages <sup>a</sup>		Hookup Drawing No.
			Heat	Cool	
Q7300A <sup>b</sup>	Conventional	T7300D, F	2	2	21-22
Q7300C <sup>b</sup>	Heat Pump	T7300E, F	3	2	23-25
Q7300D <sup>b</sup>	Heat Pump	T7300E, F	3	2	26
Q7300G <sup>b</sup>	Conventional	T7300D, F	3	3	27
Q7300H <sup>c</sup>	Heat Pump	T7300F	3	2	28
Q7300H <sup>d</sup>	Heat Pump	T7300F	3	2	29
Q7300H	Conventional	T7300F	3	3	30
Q7300H	Conventional	T7300F	2	1	31
Q7300L	Conventional <sup>e</sup>	T7300D, F	2	1	33-34

<sup>a</sup> Wallplate only.

<sup>b</sup> All subbases are down selectable and can be configured to control fewer stages than the maximum allowed.

<sup>c</sup> With O/B terminals.

<sup>d</sup> Without O/B terminals.

<sup>e</sup> Used with ML7984 Actuator and V5011 or V5013 Valve.

## ORDERING INFORMATION

When purchasing replacement and modernization products from your TRADELINE® wholesaler or distributor, refer to the TRADELINE® Catalog or price sheets for complete ordering number.

If you have additional questions, need further information, or would like to comment on our products or services, please write or phone:

1. Your local Home and Building Control Sales Office (check white pages of your phone directory).
2. Home and Building Control Customer Logistics  
Honeywell Inc., 1885 Douglas Drive North  
Minneapolis, Minnesota 55422-4386 (612) 951-1000

In Canada—Honeywell Limited/Honeywell Limitée, 155 Gordon Baker Road, North York, Ontario M2H 3N7.  
International Sales and Service Offices in all principal cities of the world. Manufacturing in Australia, Canada, Finland, France, Germany, Japan, Mexico, Netherlands, Spain, Taiwan, United Kingdom, U.S.A.

**Electrical Ratings:**

24 Vac, 50/60 Hz.  
20 to 30 Vac, 50/60 Hz.

**Batteries:**

No batteries required.

**Auxiliary Heat and Emergency Heat Indication:**

Thermostat display indicates when Auxiliary Heat or Emergency Heat are activated.

**Loss of Power:**

The thermostat will maintain programmed times and temperatures for the life of the product. The clock and day information is retained for a minimum of two hours.

**Light Emitting Diodes (LEDs):**

Two user-defined LEDs (not available on Q7300H).  
Two defined (CHECK and MAINTENANCE) LEDs on select models.  
Two additional LEDs available on select models.

**System Current Draw:**

6 VA maximum at 30 Vac, 50/60 Hz.

**Output Relay Draw:**

See Table 3.

**Table 3. Maximum Amps at 30 Vac.**

Relay	Running (A)	Inrush (A)
Fan	1.6	3.5
Heat (all stages)	1.6	3.5
Cool (all stages)	1.6	7.5
Auxiliary (Economizer)	1.6	3.5

**Temperature:**

Ratings:

Operating Ambient: 40°F to 110°F (4°C to 43°C).

Shipping: -30°F to +150°F (-34°C to +65°C).

Display Accuracy: ±1°F (±0.5°C).

**Setpoint:**

Range: 45°F to 95°F (7°C to 35°C).

Deadband: 2°F (1°C).

Default Settings: see Table 4.

**Table 4. Default Setpoints.**

Control	Occupied	Unoccupied
Heating	70°F (20°C)	55°F (13°C)
Cooling	78°F (25.5°C)	90°F (32°C)

**Remote Sensor Wiring Temperature Offset:**

Temperature offset occurs with 500 ft (157m) to 1000 ft (305m) of 2-wire cable. See Table 5.

**Table 5. Temperature Offset.**

Temperature Range	18 AWG	20 AWG	22 AWG
50-90°F	-0.4°F	-0.7°F	-1.0°F
10-32°C	-0.3°C	-0.4°C	-0.6°C

**Minimum Stage Operation Time:**

Minimum On (Heat and Cool): factory setting 2 minutes; option 0 minutes.

Minimum Off (Cool and Heat Pump): factory setting 4 minutes; option 0, 1, 3, 5 minutes.

**Humidity Ratings:**

5% to 90% RH, noncondensing.

**Clock Accuracy:**

±1 minute per month.

**Finish:**

Taupe color.

**Dimensions:**

See Fig. 1.

**Mounting Means:**

T7200 Thermostat mounts on a wallplate. The T7300 Thermostat mounts on a Q7300 Subbase. The wallplate and subbase mount horizontally on a wall or outlet box with two no. 6 x 32 screws (included).

**Accessories:**

C7150B1004 Discharge Air Sensor (form 63-2072).

C7400 Enthalpy Sensor (form 63-2140).

M7415 Damper Actuator (form 63-2100).

ML7984 Valve Actuator (form 95C-10753).

Q7760A Serial LonTalk® Adapter

R8222 Switching Relay (form 60-2056).

T675A Temperature Control (form 60-2200).

T7022A1010 Remote Temperature Sensor (form 60-0247).

T7047C Remote Temperature Sensor (form 62-3050).

T7047G Remote Temperature Sensor (form 62-3050).

T7147A Remote Temperature Sensor and Override Module (form 62-3049).

W859F Packaged Economizer (form 63-2476).

W950A System Supervisor (form 60-2351).

W7459 Economizer Logic Module (form 63-2141).

W6210/W7210 Economizer (form 63-2528).

**Approvals:**

European Community Mark (CE) Listed.

Q7300H only: LonMark® Functional Profile No. 8060, Thermostat Object (type 09).



**RECYCLING NOTICE**

If this control is replacing a control that contains mercury in a sealed tube, do *not* place your old control in the trash.

Contact your local waste management authority for instructions regarding recycling and the proper disposal of the old thermostat.

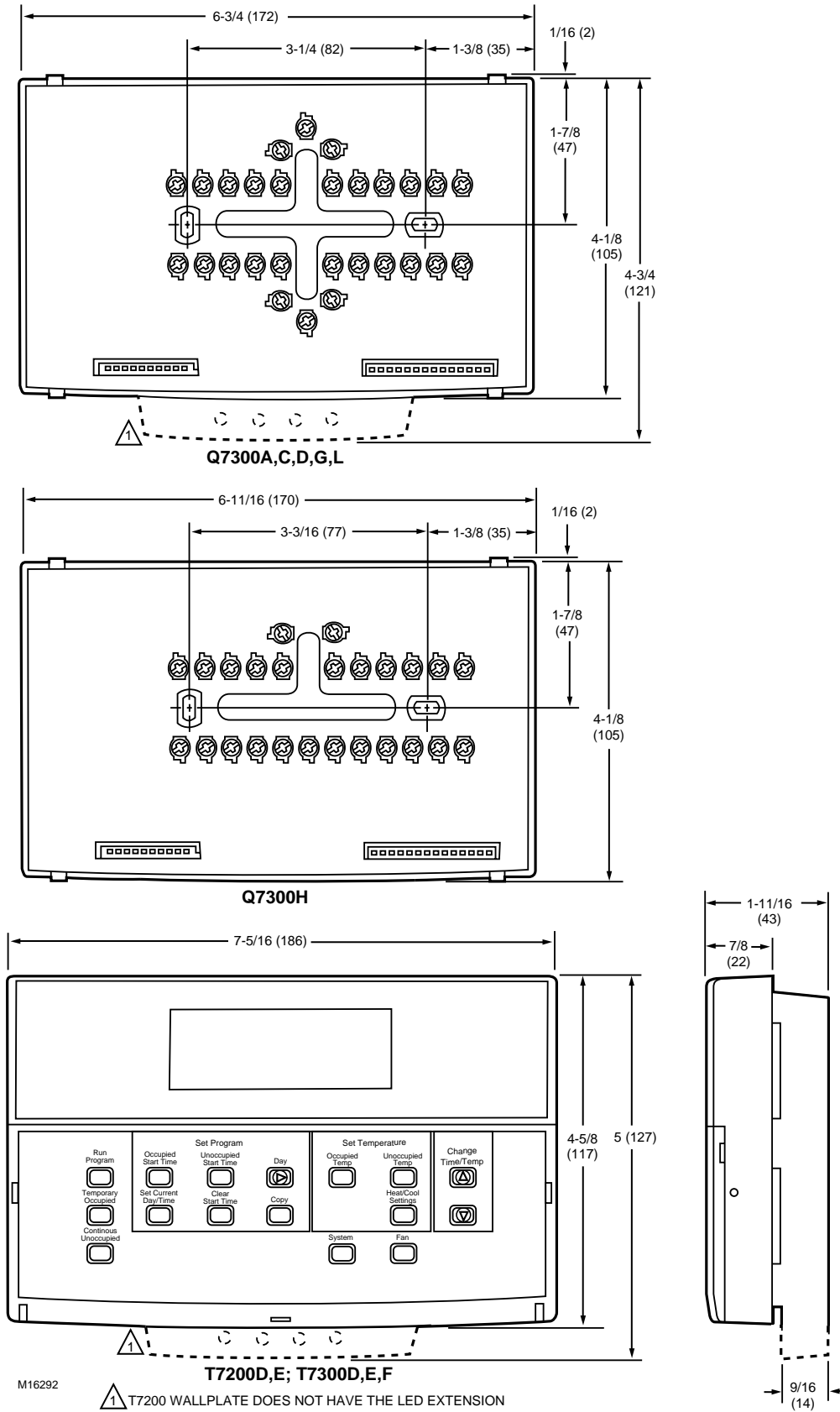

Fig. 1. Dimensions of T7200, T7300 and Q7300 in in. (mm).

## INSTALLATION

### When Installing this Product...

1. Read these instructions carefully. Failure to follow the instructions can damage the product or cause a hazardous condition.
2. Check the ratings given in the instructions and on the product to make sure the product is suitable for your application.
3. Installer must be a trained, experienced service technician.
4. After completing installation, use these instructions to check out the product operation.

### Location

#### T7200 Wallplate or Q7300 Subbase without Remote-Mounted Temperature Sensor

Install the thermostat about 5 ft (1.5m) above the floor in an area with good air circulation at average temperature. See Fig. 2.

Do not install the thermostat where it can be affected by:

- drafts, or dead spots behind doors and in corners.
- hot or cold air from ducts.
- radiant heat from sun or appliances.
- concealed pipes and chimneys.
- unheated (uncooled) areas such as an outside wall behind the thermostat.

#### Q7300 Subbase with Remote-Mounted Temperature Sensor(s)

If only the remote-mounted temperature sensor(s) is used to sense and control room temperature, then install the thermostat in an area that is accessible for setting and adjusting the temperature and settings.

If both the subbase and remote-mounted temperature sensor(s) are used to sense and control room temperature, then install the subbase about 5 ft above the floor in an area with good air circulation.

Install the remote-mounted sensor(s) about 5 ft (1.5m) above the floor in an area with good air circulation at average temperature. See Fig. 2.

Do not mount the sensor(s) where it can be affected by:

- drafts, or dead spots behind doors and in corners.
- hot or cold air from ducts.
- radiant heat from sun or appliances.
- concealed pipes and chimneys.
- unheated (uncooled) areas such as an outside wall behind the thermostat.

If more than one remote sensor are required, they must be arranged in a temperature averaging network consisting of two, three, four, five or nine sensors. See Fig. 3 through 7.

#### NOTES:

- When sensor averaging, the T7147A can be substituted for the T7047C. The T7147A includes OVERRIDE and WARMER/COOLER keys.
- Up to four T7147As can be used in parallel to place the thermostat in Temporary Occupied.

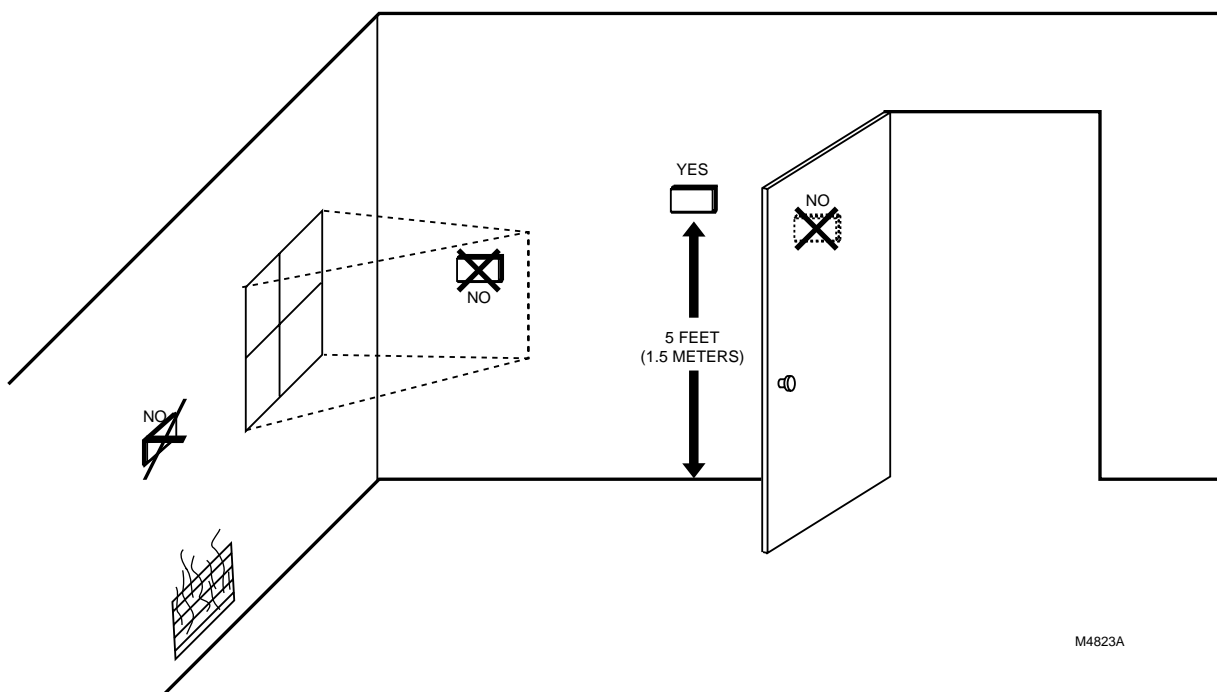
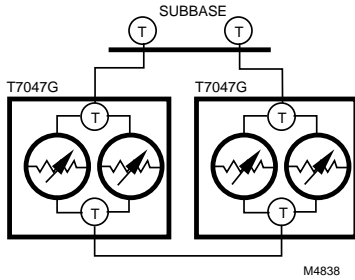

Fig. 2. Typical location of thermostat or remote-mounted sensor.

**IMPORTANT**

To avoid electrical interference, which can cause erratic performances, keep wiring runs as short as possible and do not run thermostat wires adjacent to the line voltage electrical distribution systems. Use shielded cable (Belden type 8762 or equivalent for 2-wire and Belden type 8772 or equivalent for 3-wire). The cable shield must be grounded only at the controlled equipment case.



**Fig. 3. Two T7047G Sensors providing temperature averaging network for T7300/Q7300 Thermostat/Subbase.**

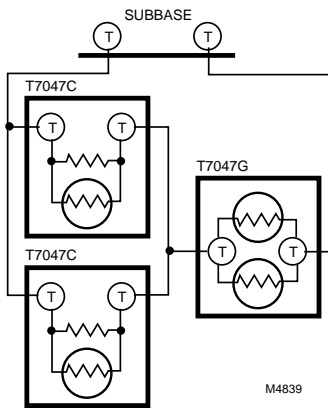

**Fig. 4. Two T7047C Sensors and one T7047G Sensor providing temperature averaging network for T7300/Q7300 Thermostat/Subbase.**

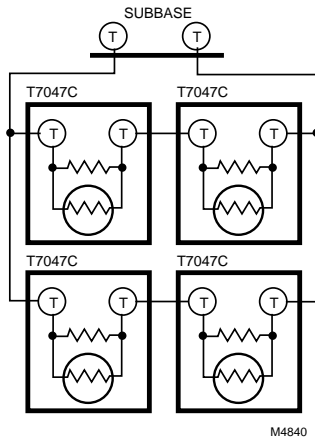

**Fig. 5. Four T7047C Sensors providing temperature averaging network for T7300/Q7300 Thermostat/Subbase.**

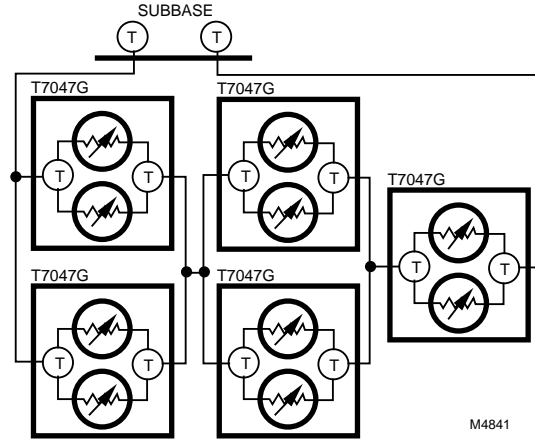

**Fig. 6. Five T7047G Sensors providing temperature averaging network for T7300/Q7300 Thermostat/Subbase.**

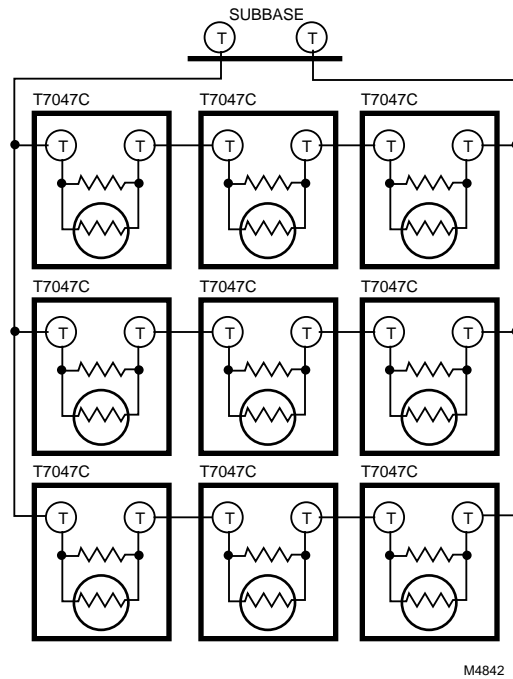

**Fig. 7. Nine T7047C Sensors providing temperature averaging network for T7300/Q7300 Thermostat/Subbase.**

**NOTE:** When thermostat is configured for temperature averaging network (remote and internal sensing), the internal sensor has 50% authority of the averaged temperature.

**Mounting Subbase or Wallplate**

The subbase or wallplate mounts horizontally on the wall or a 2 in. x 4 in. wiring box. Position the subbase or wallplate horizontally on the wall or on a 2 in. x 4 in. wiring box.

1. Position and level the subbase or wallplate (for appearance only). The thermostat functions properly even when not level.
2. Use a pencil to mark the mounting holes. See Fig. 8.

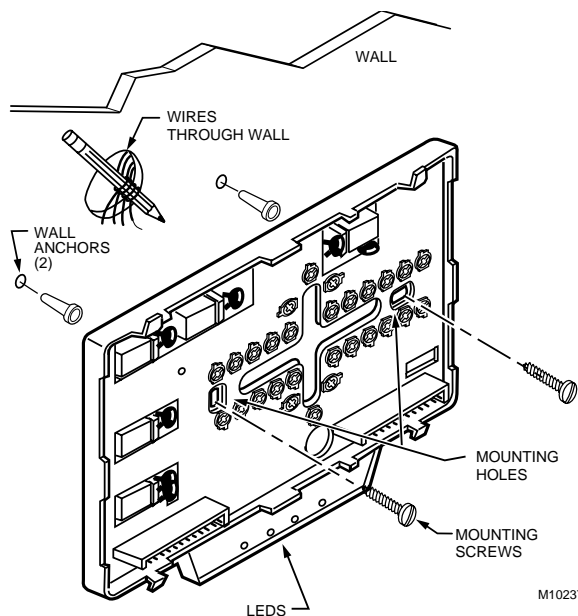

Fig. 8. Mounting subbase or wallplate.

3. Remove the subbase or wallplate from the wall and drill two 3/16 inch holes in the wall (if drywall) as marked. For firmer material such as plaster or wood, drill two 7/32 inch holes. Gently tap anchors (provided) into the drilled holes until flush with the wall.
4. Position the subbase or wallplate over the holes, pulling wires through the wiring opening.
5. Loosely insert the mounting screws into the holes.
6. Tighten mounting screws.

## WIRING SUBBASE OR WALLPLATE

All wiring must comply with local electrical codes and ordinances. Follow equipment manufacturer wiring instructions when available. Refer to Fig. 19 through 32 for typical hookups. A letter code is located near each terminal for identification. Refer to Table 6 for terminal designations.



## CAUTION

**Electrical Shock Hazard.**  
**Power supply can cause electrical shock.**  
 Disconnect power before beginning installation.

Table 6. Terminal Designations and Descriptions.

Standard Terminal Designations	Alternate Terminal Designations	Typical Connection	Function	Terminal Type
A1	A2 <sup>a</sup>	Dry auxiliary contacts for economizer control; A1 is normally open during Unoccupied periods and closed during Occupied periods.	Output	Dry contact
A1, A2	—	Damper control relay (Q7300L only).	Input, Output	24V powered contact
A2	A1 <sup>a</sup>	Dry auxiliary contacts for economizer control (A2 is common).	Input	Dry contact
A3	—	Dry auxiliary contacts for economizer control; A3 is normally open during Occupied periods and closed during Unoccupied periods.	Output	Dry contact
AS, AS	—	C7150B Discharge Air Sensor connection.	Input	—
B	—	Heating changeover valve.	Output	24V powered contact
C1, C2, C3, C4, C5	—	Communication input for T7147.	Input	Low power
E	K	Emergency heat relay.	Output	24V powered contact
EB, EB	—	Q7300H LonWorks® bus connection to LonWorks® network.	Input, Output	Communi-cations
G	F	Fan relay.	Output	24V powered contact
O	R	Cooling changeover valve.	Output	24V powered contact
R	V	24V system transformer.	Input	—
RC	—	24V cooling transformer.	Input	—
RH	—	24V heating transformer.	Input	—
T, T	—	Remote sensor input for T7047 or T7147.	Input	—

<sup>a</sup> Some OEM models reverse the economizer terminal designations A1 and A2.

(continued)

**Table 6. Terminal Designations (continued).**

Standard Terminal Designations	Alternate Terminal Designations	Typical Connection	Function	Terminal Type
W1	H1, R3	Stage 1 heating relay (Q7300A, G, H) or auxiliary heat relay (Q7300C, D, H).	Output	24V powered contact
W2	H2, R4, W3, Y	Stage 2 heating relay.	Output	24V powered contact
W3	—	Stage 3 heating relay.	Output	24V powered contact
X	B <sup>b</sup> , C, X1, X2	Common.	Input	
X1, X3	A, A1, A2, C, L, X, Z	User defined Light Emitting Diodes (LEDs).	Annunciation	—
X4	—	LED common.	Annunciation	—
Y1	C1, M, Y	Stage 1 compressor contactor (Q7300C, D, H).	Output	24V powered contact
Y1, Y	RS, M	Stage 1 cooling compressor (Q7300A, G, H <sup>c</sup> , L).	Output	24V powered contact
Y2	C2	Stage 2 cooling compressor (conventional). Stage 2 compressor contactor (heat pump).	Output	24V powered contact
Y3	—	Stage 3 cooling compressor.	Output	24V powered contact
BM	—	ML7984 Actuator connection (Q7300H <sup>c</sup> , L only); no call for heat, valve closed; call for stage 1 heat, valve approximately one-half open; call for stage 2 heat, valve fully open.	Output	—
FC	—	Fan control transformer (Q7300H <sup>c</sup> , L only).	Input	—
GH	—	High-speed fan output (Q7300H <sup>c</sup> , L only); activate during calls for cooling.	Output	24V powered contact
GL	—	Low-speed fan output (Q7300H <sup>c</sup> , L only); activated on calls for heat and fan On selection.	Output	24V powered contact
P1, P2	—	Pump interlock relay (Q7300H <sup>c</sup> , L only); operates circulator pump in hydronic heat or energizes conventional heat system.	Input, Output	24V powered contact
RM	—	ML7984A Actuator connection (Q7300H <sup>c</sup> , L only); no call for heat, valve closed; call for stage 1 heat, valve approximately one-half open; call for stage 2 heat, valve fully open.	Output	—
—	C, H, L	HSII Control Panel.	—	—
—	O	Momentary circuit changeover.	—	—
—	P	Defrost.	—	—
—	R1, R2	Low- and high-speed fan relays.	—	—
—	T	External temperature readout, T-relay; outdoor thermistor.	—	—

<sup>a</sup> Some OEM models reverse the economizer terminal designations A1 and A2.

<sup>b</sup> Some OEM models label the terminal for transformer common B.

<sup>c</sup> Only applies to Q7300H2037 model.

1. Loosen the terminal screws on the subbase or wallplate and connect the system wires. See Fig. 9.

2. Securely tighten each terminal screw.
3. Push excess wire back into the hole.
4. Plug the hole with nonflammable insulation to prevent drafts from affecting the thermostat.

**IMPORTANT**

*Use 18-gauge, solid-conductor color-coded thermostat cable for proper wiring. If using 18-gauge stranded wire, no more than ten wires can be used. Do not use larger than 18-gauge wire.*



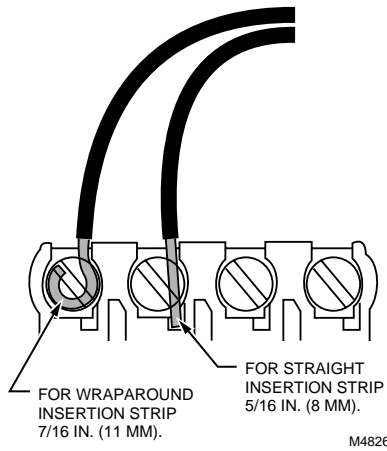

Fig. 9. Proper wiring technique.

## Mounting Thermostat on Subbase or Wallplate

The thermostat mounts on the subbase or wallplate after they are installed.

1. Engage the tabs at the top of the thermostat and subbase or wallplate. See Fig. 10.
2. Press the lower edge of the case to latch.

NOTE: To remove the thermostat from the wall, first pull out at the bottom of the thermostat; then remove the top.

A. ENGAGE TABS AT TOP OF THERMOSTAT AND SUBBASE OR WALLPLATE.

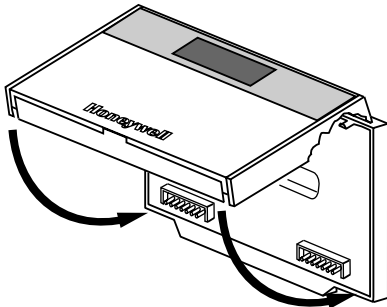

B. PRESS LOWER EDGE OF CASE TO LATCH.

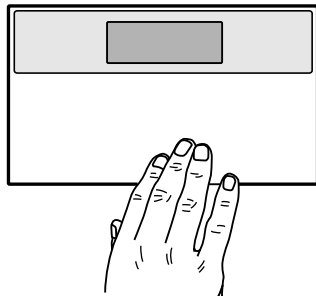

Fig. 10. Mounting thermostat on subbase or wallplate.

## SETTINGS

### Using Thermostat Keys

The thermostat keys are used to:

- set current time and day,
- program times and setpoints for heating and cooling,
- override the program temperatures,
- display present setting,
- set system and fan operation,
- configure Installer Setup,
- check Installer System Test.

See Fig. 11 for key information.

### Setting System and Fan (select models)

The system default setting is Heat. The fan default is set so the fan operates continuously in Occupied periods, Unoccupied period recovery times and with the heating and cooling equipment in Unoccupied periods. Use the System and Fan keys to change the settings. Fan and system operation are configured in the Installer Setup options.

The system settings are:

- Em Heat (T7200E, T7300/Q7300C,D,H): Emergency heat relay is on continuously. Thermostat cycles highest stage of heat. Cooling system is off. Compressor is de-energized.
- Heat: Thermostat controls the heating.
- Off: Both the heating and cooling are off.
- Cool: Thermostat controls the cooling.
- Auto: Thermostat automatically changes between heating and cooling depending on the indoor temperature.

The fan settings are:

- On: Fan operates continuously in occupied period.
- Auto: Equipment controls the fan in the Unoccupied periods. The Intelligent Fan™ operation (Installer Setup number 17) offers three choices for the fan operation in Occupied periods:
  - fan turns on only when there is a call for heating or cooling.
  - fan operates continuously in Occupied periods.
  - fan is on continuously in Occupied periods and Unoccupied period recovery times.

### Setting Temperature

Refer to Table 7 for the default temperature setpoints. See Programming section for complete instructions on changing the setpoints.

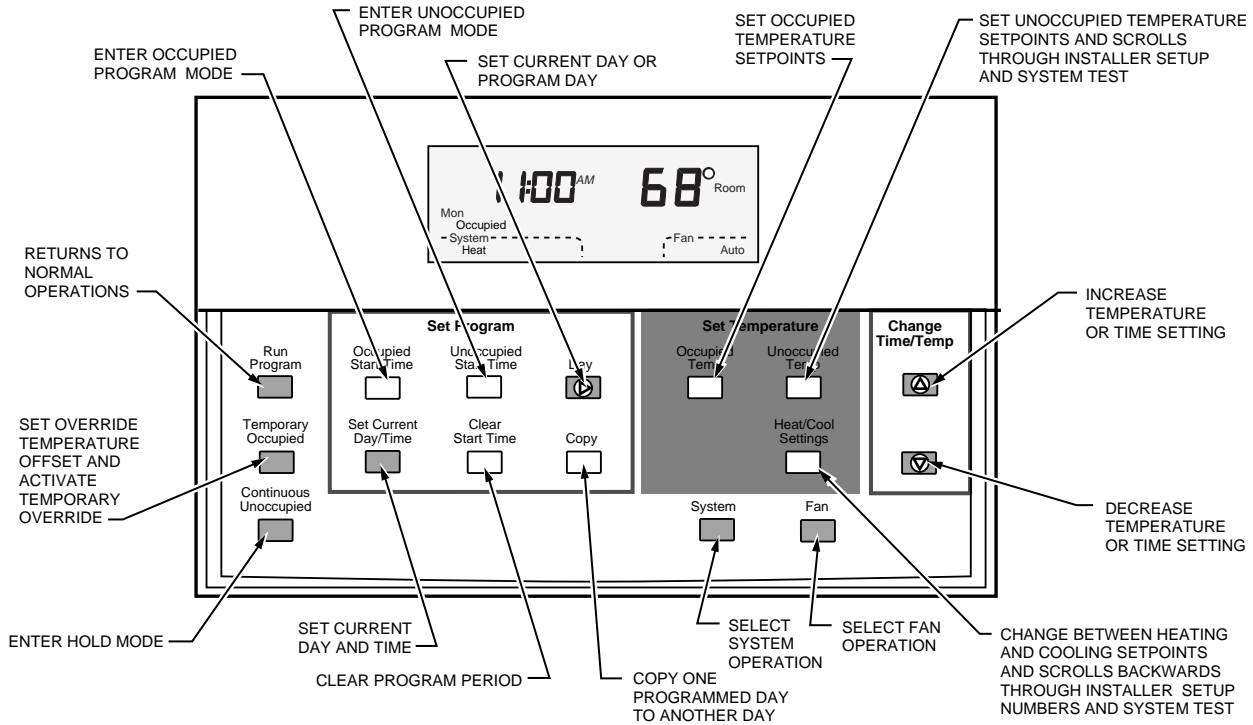
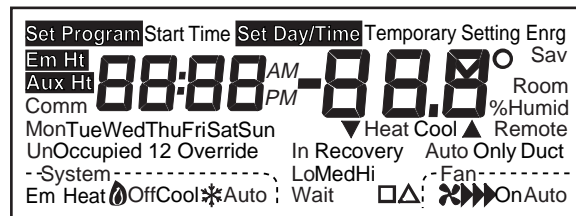

Fig. 11. Thermostat key locations and descriptions.

M10233A

Table 7. Default Temperature Setpoints.

Control	Occupied	Unoccupied
Heating	70°F (20°C)	55°F (13°C)
Cooling	78°F (25.5°C)	90°F (32°C)



M4916

Fig. 12. LED display of all segments.

## INSTALLER SETUP

NOTE: For most applications, the thermostat factory settings do not need to be changed. Review the factory settings in Table 8 and if no changes are necessary, go to the Installer System Test section.

The Installer Setup is used by the installer to customize the thermostat to specific systems. Installer Setups are listed in Table 8. The table includes all the configuration options available.

A combination of key presses are required to use the Installer Setup feature.

- To enter the Installer Setup, press and hold the Heat/Cool Settings key and both the increase  $\Delta$  and  $\nabla$  decrease keys until the first number is displayed. All display segments appear for approximately three seconds before the number is displayed. See Fig. 12 and 13.

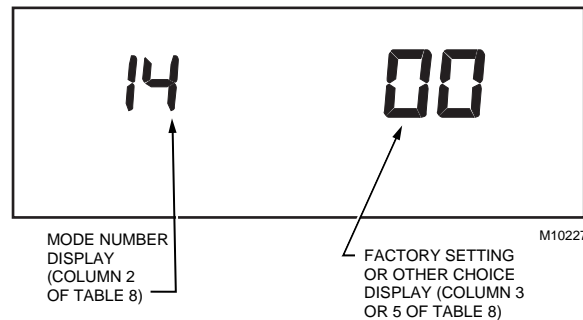

Fig. 13. Installer Setup number and setting display.

- To advance to the next Installer Setup number, press the Unoccupied Temp key.
- To return to an Installer Setup number, press the Heat/Cool Settings key.
- To change a setting, use the increase  $\triangle$  or  $\nabla$  decrease key.
- To exit the Installer Setup, press the Run Program key. The Installer Setup is automatically exited if no key presses are made for four minutes.



## CAUTION

**Possible Equipment Damage.**  
**Fan must be running when system is operating.**  
 Heat pump and electric heat systems must be configured correctly in Installer Setup 2 to prevent equipment damage caused by the system running without the fan.

NOTE: Be sure to set the thermostat time after exiting the Installer Setup.

Installer Setup numbers are listed in Table 8.

### IMPORTANT

*Only configurable numbers are shown on the device. Example: If the thermostat does not have a system key, Installer Setup number 12 will not be displayed. Review Table 8 factory settings and mark any desired changes in the Actual Setting column. When the Installer Setup is complete, review the settings to confirm that they match the system.*

**Table 8. Thermostat Installer Setup Options.**

Select	Installer Setup Number (Press Unoccupied Temp key to change)	Factory Setting		Other Choices (Press $\triangle$ or $\nabla$ key to change)		Actual Setting
		Display	Description	Display	Description	
Not used	1	—	—	—	—	—
Fan operation <sup>a</sup>	2	0	Conventional applications where equipment controls fan operation in heat mode.	1	Electric heat applications where thermostat controls fan operation in heat mode.	
Output stages of heating	3	Depends on subbase	Stages of heat.	0, 1, 2, or 3	0—No heating. 1—One stage of heat. 2—Two stages of heat. 3—Three stages of heat.	
Heating cycle rate	4	4	Stage 1—4 cph.	3, 6, 8 or 9	3—3 cph used for hot water systems or high efficiency furnaces.  6—6 cph used for conventional systems. 8—8 cph used for conventional systems. 9—9 cph used for electric heat systems.	
	5	4	Stage 2—4 cph.			
	6	4	Stage 3—4 cph.			
	7	4	Emergency heat relay is on continuously. Highest stage of heat cycles at 4 cph (Q7300C or D only).			
Output stages of cooling	8	Depends on subbase	Stages of cooling.	0, 1, 2 or 3	0—No cooling. 1—One stage of cool. 2—Two stages of cool. 3—Three stages of cool.	
Cooling cycle rate	9	4	Stage 1—4 cph.	3	3—3 cph.	
	10	4	Stage 2—4 cph.			
	11	4	Stage 3—4 cph.			
System setting adjustment (models with System key)	12	Depends on model	System selection.	0, 1 or 2	0—System setting key is operational. 1—Auto setting is disabled. 2—Auto only setting.	
Not used	13	—	—	—	—	—
Degree temperature display	14	0	Temperature is displayed in °F.	1	Temperature is displayed in °C.	

<sup>a</sup>Number 2 must be set to 1 to extend fan operation.

(continued)

**Table 8. Thermostat Installer Setup Options (Continued).**

Select	Installer Setup Number (Press Unoccupied Temp key to change)	Factory Setting		Other Choices (Press $\Delta$ or $\nabla$ key to change)		Actual Setting
		Display	Description	Display	Description	
Displaying temperature (T7300F only).	15	0	Temperature is displayed.	1	Temperature is not displayed.	
Clock format.	16	0	12-hour clock format.	1	24-hour clock format.	
Intelligent Fan™ operation.	17	2	Fan operates continuously in Occupied and recovery modes. Fan operates with call for heating or cooling in Unoccupied mode.	0 or 1	0—Fan only operates with calls for heating or cooling in Occupied and Unoccupied modes. 1—Fan operates continuously in Occupied mode. Fan operates with calls for heating or cooling in Unoccupied mode.	
Auxiliary contact operation.	18	0	0—Time of day contact.	0 or 1	1—Economizer contacts.	—
Extended fan operation in heating <sup>a</sup> (T7300F only).	19	0	No extended fan operation after the call for heat ends.	1	Fan operation is extended 90 seconds after the call for heat ends.	
Extended fan operation in cooling (T7300 only).	20	0	No extended fan operation after the call for cool ends.	1	Fan operation is extended 90 seconds after the call for cool ends.	
Fan key adjustment (models with Fan key).	21	0	Fan setting key is operational.	1	Fan setting key is Auto only.	
Remote sensing.	22	0	Remote sensing not activated.	1	Remote sensing activated.	
Temperature averaging network <sup>b</sup> (T7300 only).	23	0	Temperature averaging disabled.	1	Temperature averaging between local sensor and remote sensor(s) activated.	
Not used.	24	—	—	—	—	—
Keypad lockout level (keypad lockout is enabled and disabled by DIP switch 1 on back of thermostat).	25	0	No lockout.	1 or 2	1—Lockout all keys on thermostat except system and fan settings, temporary setpoint, clock and day adjustments, increase $\Delta$ and $\nabla$ decrease keys. 2— Lockout all keys except Set Current Day/Time, increase $\Delta$ and decrease $\nabla$ keys. 3—Lockout all keys except Temporary Occupied and Set Current Day/Time (for clock, day adjustment).	
Duration of temporary override.	26	3	3—Three hour override.	1, 8 or 12	1—One hour override. 8—Eight hour override. 12—Twelve hour override.	
Not used.	27 thru 29	—	—	—	—	—
Deadband (T7300F only).	30	2	Heating and cooling setpoints can be set no closer than 2°F (1.1°C).	3 thru 10	Heating and cooling setpoints can be set no closer than the chosen value.	

<sup>b</sup>Number 22 must be set to 1 and remote sensor(s) must be installed.

(continued)

Table 8. Thermostat Installer Setup Options (Continued).

Select	Installer Setup Number (Press Unoccupied Temp key to change)	Factory Setting		Other Choices (Press $\Delta$ or $\nabla$ key to change)		Actual Setting
		Display	Description	Display	Description	
Interstage control point (T7300F, Q7300C,D only).	31	0	Disabled.	1 thru 12	Temperature has to change more than the chosen value before the system calls for the next stage. (Example: 68°F (20°C) is the heat setpoint, 2°F (1.1°C) is the interstage setting, temperature is 65.5°F (18.5°C), the second stage turns on, brings the temperature to 66°F (19°C) and turns off. The heat pump continues to run until the setpoint is met.	
Minimum on-time (T7300F).	32	2	2-minute minimum on-time for heating and cooling.	0 or 1	No minimum on-time or 1-minute minimum on-time for heating and cooling.	
Minimum off-time for the compressor.	33	4	4-minute minimum off-time for the compressor.	0, 1, 2, 3 or 5	Minimum number of minutes (0 thru 5) the compressor is off between calls for the compressor.	
Temperature range stops in heating (T7300F).	34	90	Highest heating setpoint.	40 to 89	Temperature range (1°F increments) for heating setpoint.	
Temperature range stops in cooling (T7300F).	35	45	Lowest cooling setpoint.	46 to 99	Temperature range (1°F increments) for cooling setpoint.	
Not used.	36	—	—	—	—	—
Temperature display adjustment.	37	0	No difference in displayed temperature and actual room temperature.	1 thru 6	1—Display adjusts to 1°F (0.6°C) higher than actual room temperature. 2—Display adjusts to 2°F (1.1°C) higher than actual room temperature. 3—Display adjusts to 3°F (1.7°C) higher than actual room temperature. 4—Display adjusts to 1°F (0.6°C) lower than actual room temperature. 5—Display adjusts to 2°F (1.1°C) lower than actual room temperature. 6—Display adjusts to 3°F (1.7°C) lower than actual room temperature.	
Minimum off-times in heating.	38	4	4—4-minute minimum off-time	0, 1, 2, 3, or 5	Minimum number of minutes (0 thru 5) the heating equipment is off between calls for heat.	
Not used.	39	—	—	—	—	—
Installer Setup lockout (keypad lockout is enabled and disabled by DIP switch 1 on back of thermostat).	40	0	0—No Installer Setup lockout.	1	1—Installer Setup lockout activated.	

**IMPORTANT**

Review the settings to confirm that they match the system. Press Run Program to exit the Installer Setup. The thermostat has saved the Installer Setup changes and initiated reset in order to operate with these new settings. Be sure to set the current day and time immediately.

**Setting Current Time/Day**

1. Press Set Current Day/Time.

NOTE: On initial power up or after an extended power loss, 1:00 pm flashes on the display until a key is pressed.

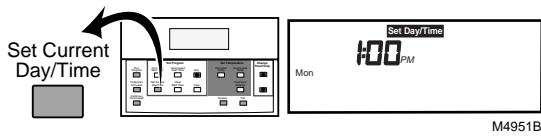

2. Press Day until the current day is displayed.

NOTE: Sun = Sunday, Mon = Monday, Tue = Tuesday, Wed = Wednesday, Thu = Thursday, Fri = Friday, Sat = Saturday.

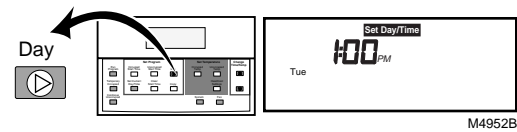

3. Press increase  $\Delta$  or decrease  $\nabla$  key until the current time is displayed.

NOTE: Tapping the Set Current Day/Time will change the time in one hour increments.

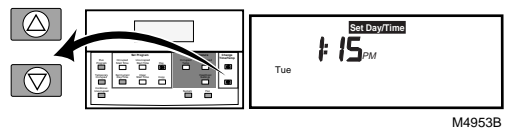

4. Press Run Program.

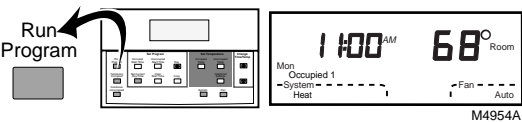

**INSTALLER SYSTEM TEST**

Use the Installer System Test to check the thermostat configurations and operation. Refer to Table 9 for a list of the available system tests.

To start the system test:

**CAUTION**

**Possible Equipment Damage.**  
Equipment damage can result if compressor is cycled too quickly.

The minimum off time for compressors is bypassed during the Installer System Test. Equipment damage can occur if the compressor is cycled too quickly.

Press and hold the increase  $\Delta$  and decrease  $\nabla$  keys, at the same time, until 10 appears. All segments of the LCD are displayed for three seconds before 10 appears. See Fig. 14 and 15.

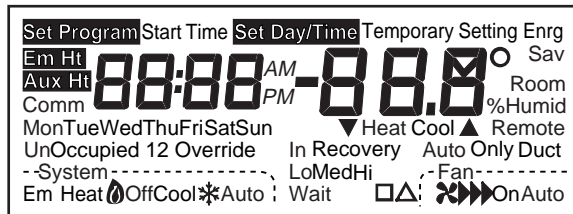

Fig. 14. LCD display of all segments.

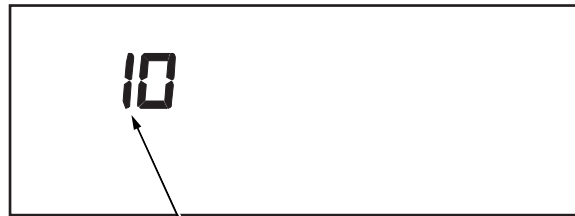

Fig. 15. Test number display.

Table 9. Tests Available in Installer System Test.

Test Number	System Test Description
10 to 19	Heating equipment can be turned on and off.
20 to 29	Emergency heat (Q7300C,D, H only) equipment can be turned on and off.
30 to 39	Cooling equipment can be turned on and off.
40 to 49	Fan equipment can be turned on and off.
60 0 to 60 19	Keyboard keys test.
70 to 79	Thermostat information including date code and software versions are displayed.

NOTE: If a duct temperature sensor is installed (T7300F only), the duct temperature is also displayed.

Refer to Table 10 and Thermostat Information section for directions and results of the specific system tests.

NOTE: Press Run Program to exit the system test. The system test times out after four minutes without any key presses.

Table 10. Installer System Test Options.

Key to Press	Test Number	Description
<b>Heating Equipment System Test</b>		
<b>Heat/Cool Settings</b>	10	Enter heating equipment system test.
△	11	Stage-one heat turns on. The system fan is also energized.
△	12	Stage-two heat turns on. Stage-one heat and system fan remain on.
△	13	Stage-three heat turns on. Stage-one and stage-two heat with the system fan are on.
▽	12	Stage-three heat turns off.
▽	11	Stage-two heat turns off.
▽	10	Stage-one heat and system fan turn off.
<b>Emergency Heating Equipment System Test (T7300E,F with Q7300C,D)</b>		
<b>Heat/Cool Settings</b>	20	Change from heating to emergency heating equipment system test (Em Heat on).
△	21	Fan turns on.
▽	20	Fan and highest stage heat turns off.
<b>Cooling Equipment System Test</b>		
<b>Heat/Cool Settings</b>	30	Change from heating or emergency heating to cooling equipment system test.
△	31	Stage-one cooling and system fan turn on.
△	32	Stage-two cool turn on. Stage-one cool and system fan remain on.
△	33	Stage-three cool turns on (Q7300G, H only). Stage-one and stage-two cool with system fan remain on.
▽	32	Stage-three cool turns off.
▽	31	Stage-two cool turns off.
▽	30	Stage-one cool and system fan turn off.
<b>Fan Equipment System Test</b>		
<b>Heat/Cool Settings</b>	40	Change from cooling to fan equipment system test.
△	41	Fan turns on.
△	42	High speed fan turns on (Q7300H <sup>a</sup> , L only).
▽	41	High speed fan turns off.
▽	40	Fan turns off.
<b>Key Operation System Test</b>		
<b>Heat/Cool Settings</b>	60 2	Change from fan to key operation system test.
<b>Unoccupied Temp</b>	60 0	Unoccupied Temp test number is displayed.
<b>Occupied Temp</b>	60 1	Occupied Temp test number is displayed.
△	60 3	Increase test number is displayed.
▽	60 5	Decrease test number is displayed.
<b>Clear Start Time</b>	60 7	Clear Start Time test number is displayed.
<b>Day</b>	60 8	Day test number is displayed.
<b>Copy</b>	60 9	Copy test number is displayed.
<b>Unoccupied Start Time</b>	60 10	Unoccupied Start Time test number is displayed.
<b>System (select models)</b>	60 11	System test number is displayed.
<b>Fan (select models)</b>	60 12	Fan test number is displayed.
<b>Set Current Day/Time</b>	60 14	Set Current Day/Time test number is displayed.
<b>Run Program</b>	60 15	Run Program test number is displayed.
<b>Temporary Occupied</b>	60 16	Temporary Occupied test number is displayed.
<b>Occupied Start Time</b>	60 17	Occupied Start Time test number is displayed.
<b>Continuous Unoccupied</b>	60 19	Continuous Unoccupied test number is displayed.

<sup>a</sup>Only applies to Q7300H2037 model.

## Thermostat Information

1. Press the Heat/Cool Settings key to access the thermostat information.



2. Press the increase  $\Delta$  key to display the production date code. The first two large digits are the month and the third digit is the last digit of the year. (Example: 036 = March 1996).

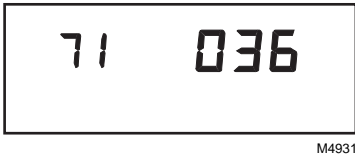

3. Press the increase  $\Delta$  key again to display the software identification code. (Example: 02 = software ID code 2).



4. Press the increase  $\Delta$  key again to display the software revision number. (Example: 001 = revision number 1).

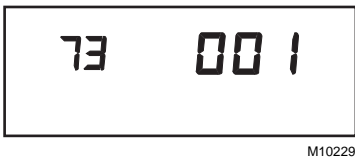

5. Press the increase  $\Delta$  key again to display the EEPROM identification code. (Example: 314 = EEPROM ID 313).

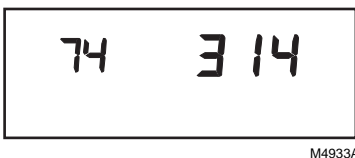

6. Press the increase  $\Delta$  key again to display the subbase identification code. (Example: HP = heat pump subbases).



7. Press Run Program to exit the self-test. The self-test times out after four minutes without any key presses.

## Setting Keypad Lockout Switch

The DIP switch 1, on the back of the thermostat, activates the lockout features. The switch must be set to the ON position (up) to activate the lockout feature. See Fig. 16. The factory setting is off (down). Remove the thermostat from the subbase and set the switch to ON if keypad lockout is desired. The level of lockout is determined by the Installer Setup numbers 25 and 40.

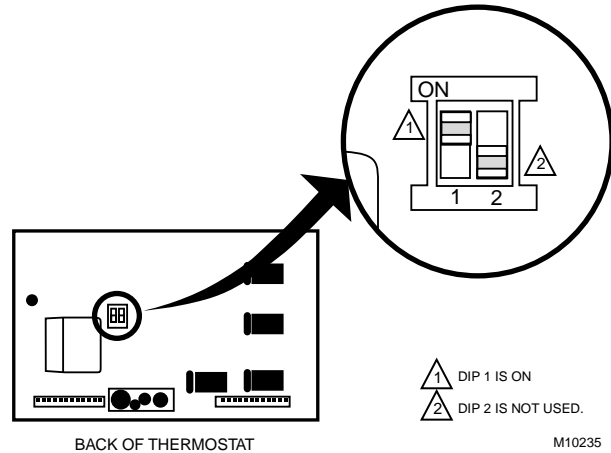

Fig. 16. Set the keypad lockout DIP switch 1 on back of thermostat.

## PROGRAMMING

The keyboard is located behind the thermostat cover. Up to sixteen keys are used to set, review and modify programmed times and temperature settings. The thermostat display shows day, time, program period and temperature.

The thermostat can be set for two Occupied and two Unoccupied times for each day of the week (28 independent time settings). Temporary Occupied key provides quick temporary temperature changes for increased occupant comfort. The Continuous Unoccupied key provides energy efficient operation for extended periods of time.

### IMPORTANT

*To program the thermostat, 24 Vac is required (turn on system power). The keyboard lockout feature must be disabled by setting the DIP switch 1 on the back of the thermostat to the Off position.*

Before starting the program procedure, use Table 11 to organize the program schedule.



**Table 11. Occupied and Unoccupied Periods Start Times.**

Day	Occupied Period 1	Unoccupied Period 1	Occupied Period 2	Unoccupied Period 2
Monday				
Tuesday				
Wednesday				
Thursday				
Friday				
Saturday				
Sunday				

The program has four temperature settings, Occupied and Unoccupied heat and cool. The thermostat operates at the Unoccupied temperature setting unless the thermostat is programmed. Table 12 shows the default temperature settings.

**Table 12. Occupied and Unoccupied Default Temperature Settings.**

Control	Occupied	Unoccupied
Heating	70°F (20°C)	55°F (13°C)
Cooling	78°F (25.5°C)	90°F (32°C)

### Setting Current Day/Time

1. Press Set Current Day/Time.

NOTE: On initial power up or after an extended power loss, 1:00 pm flashes on the display until a key is pressed.

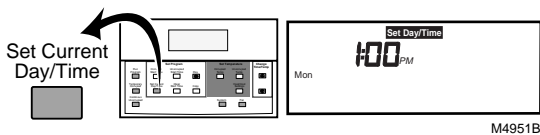

2. Press Day until the current day is displayed.

NOTE: Sun = Sunday, Mon = Monday, Tue = Tuesday, Wed = Wednesday, Thu = Thursday, Fri = Friday, Sat = Saturday.

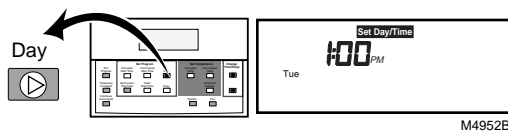

3. Press increase  $\Delta$  or decrease  $\nabla$  key until the current time is displayed.

NOTE: Tapping the Set Current Day/Time changes the time in one hour increments.

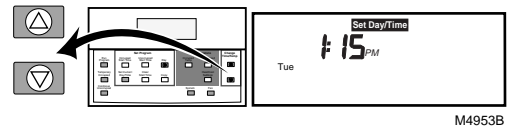

4. Press Run Program.

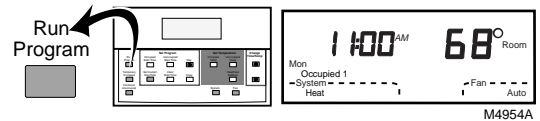

### Setting Program Times

1. Press Occupied Start Time.

NOTE: Anytime a start time is not required, press the Clear Start Time.

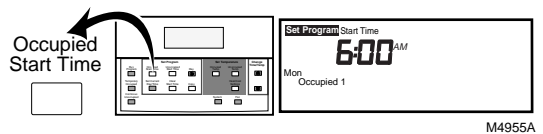

2. Press Day until the desired day is displayed.

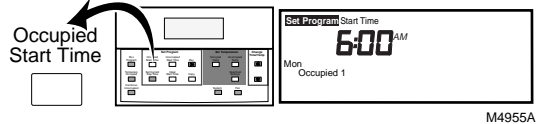

3. Press increase  $\Delta$  or decrease  $\nabla$  key until the desired start time is displayed.

NOTE: The program times are in fifteen minute intervals. (Example: 8:00, 8:15, 8:30).

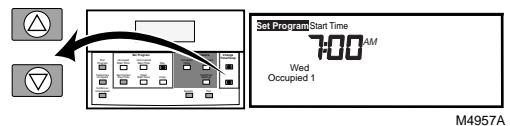

4. Press Occupied Start Time a second time to set a second Occupied Start Time.

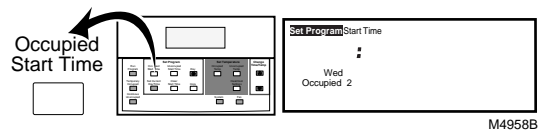

- Press increase  $\Delta$  or decrease  $\nabla$  key until the desired start time is displayed.

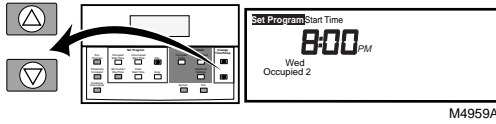

- Press Unoccupied Start Time.

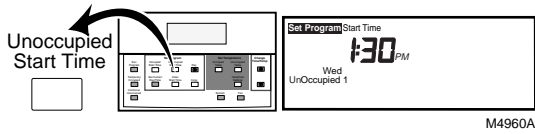

- Press increase  $\Delta$  or decrease  $\nabla$  key until the desired start time is displayed.

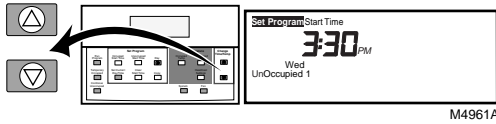

- Press Unoccupied Start Time a second time to set a second Unoccupied Start Time.

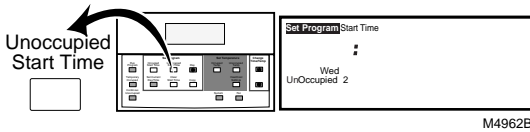

- Press increase  $\Delta$  or decrease  $\nabla$  key until the desired start time is displayed.

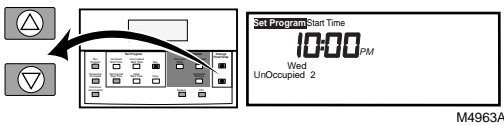

## Copying a Day

NOTE: The thermostat must be in program mode to use the copy feature. Go to step 2, if the thermostat is already in the program mode.

- Press Occupied Start Time.

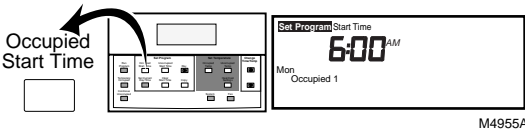

- Press Day to select the day to be copied if different from the day displayed.

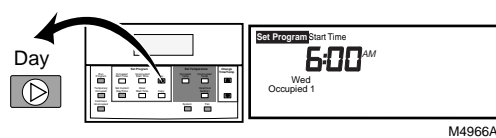

- Press Copy.

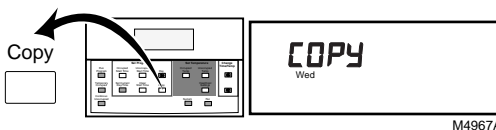

- Press Day until the day to be copied to is displayed.

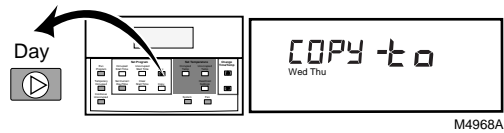

- Press Copy.

NOTE: donE will be displayed for two seconds and then the program display is shown.

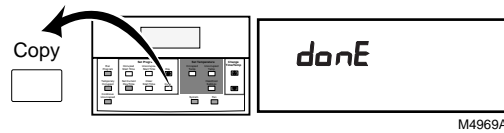

- Repeat steps 3 through 5 for all the days desired.

- Press Run Program.

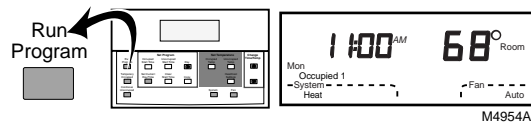

## Setting Program Temperature Setpoints

NOTE: The setpoint temperature range is 40°F to 90°F (7°C to 31°C) for heating and 45°F to 99°F (9°C to 37°C) for cooling.

- Press Occupied Temp.

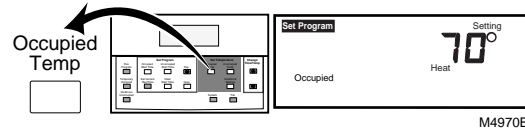

- Press increase  $\Delta$  or decrease  $\nabla$  key until the desired temperature is displayed.



- Press Heat/Cool Settings to change between heat and cool settings.

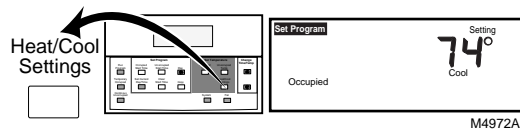

- Press increase  $\Delta$  or decrease  $\nabla$  key until the desired temperature is displayed.

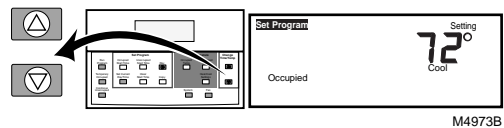

5. Press Unoccupied Temp.

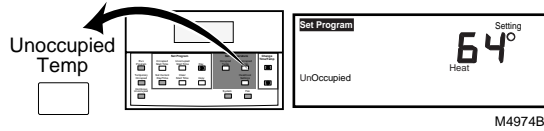

6. Press increase  $\Delta$  or decrease  $\nabla$  key until the desired temperature is displayed.

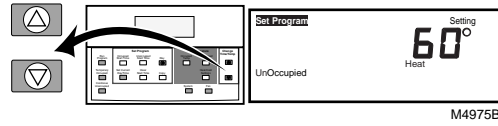

7. Press Heat/Cool Settings to change between heat and cool settings.

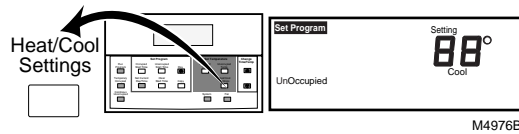

8. Press increase  $\Delta$  or decrease  $\nabla$  key until the desired temperature is displayed.

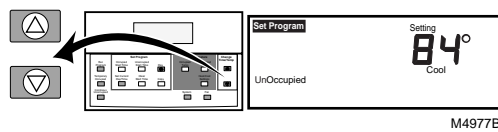

9. Press Run Program.

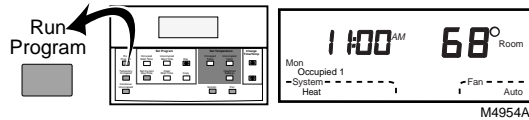

5. Press Run Program.

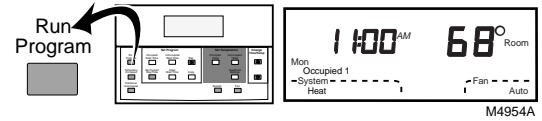

## Temporary Occupied Override

### Setting Temperature Offset for Temporary Override

1. Press Occupied Temp.

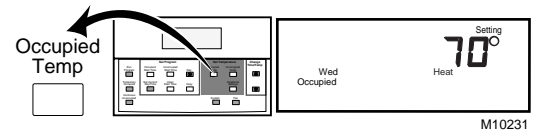

2. Press Temporary Occupied.

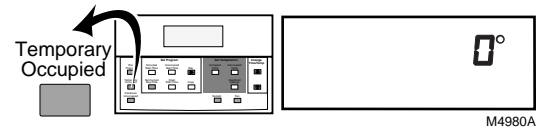

3. Press increase  $\Delta$  or decrease  $\nabla$  key until the desired temperature offset is displayed (range is 0°F to 5°F).

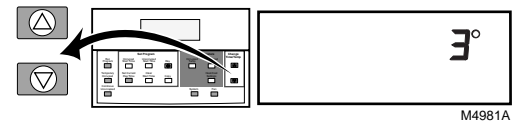

4. Press Run Program.

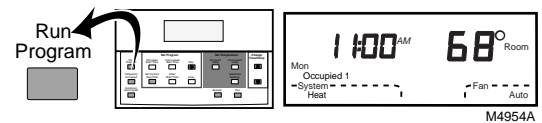

## Clearing Program Start Times

1. Press Occupied Start Time or Unoccupied Start Time until the start time to be cleared is displayed.

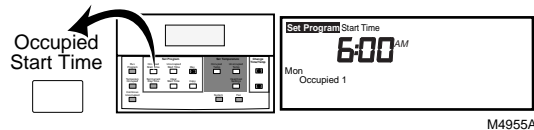

2. Press Day until the desired day is displayed.

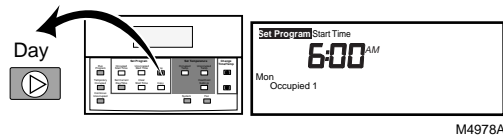

3. Press Clear Start Time.

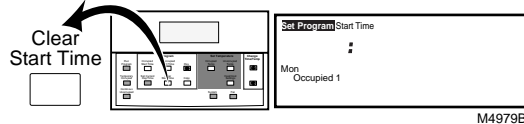

4. Repeat steps 1 through 3 for all the start times to be cleared.

## Using Temporary Override

NOTE: The temporary override temperature is held for one, three, eight or twelve hours (depending on installer setup number 26) and then the thermostat returns to the program.

1. Press Temporary Occupied.

NOTE: The default temperature setting is the Occupied setpoint.

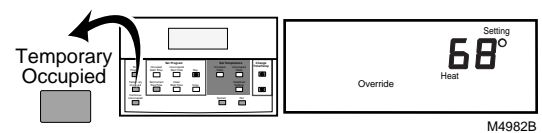

- Press increase  $\Delta$  or decrease  $\nabla$  key to change the default setting by the offset (range is 0°F to 5°F), if desired.

NOTE: If the offset is zero, the default setting changes in one degree increments. If the offset is 1 through 5, the default setting changes by  $\pm$  the offset.

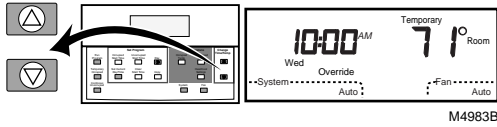

- Press Run Program to cancel the override.

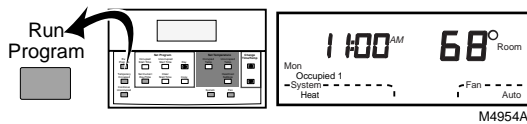

## Using Continuous Unoccupied

- Press Continuous Unoccupied.

NOTE: The default temperature setting is the Unoccupied setpoint. The default appears for approximately five seconds and then the display shows the room temperature.

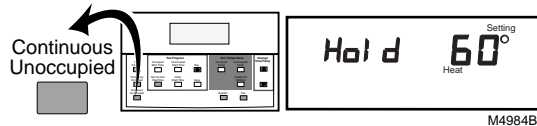

- Press increase  $\Delta$  or decrease  $\nabla$  key to change the default setting, if desired.

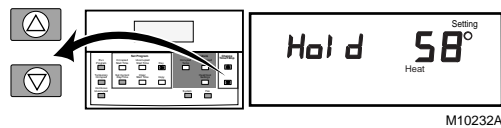

- Press Heat/Cool Settings to change between heat and cool settings. Use increase  $\Delta$  or decrease  $\nabla$  key to adjust the temperature settings.
- Press Run Program to cancel the Hold and to return to the program.

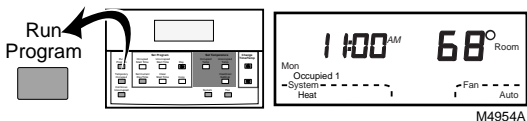

## Changing Temperature Setpoint Until Next Program Period

- Press increase  $\Delta$  or decrease  $\nabla$  key until the desired temperature is displayed.

NOTE: If  $\blacktriangle$  or  $\blacktriangledown$  appear under the temperature display, it means that both the heating and cooling setpoints are being adjusted. Tapping the key changes both the heat and cool setpoints by one degree. Press Heat/Cool Settings after the desired setpoint is reached to review the settings.

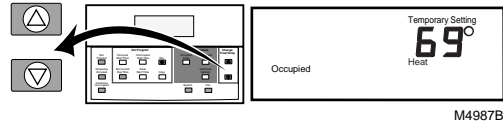

- Press Run Program to cancel the Hold and to return to the program.

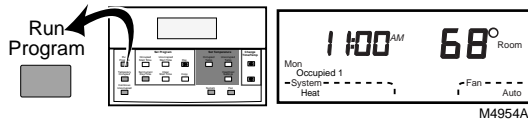

## OPERATION

### T7200/T7300 Relay Logic

The T7200/T7300 contains three switching relays. In conventional applications, the relays control first stage cooling, first stage heating, and fan. In heat pump applications, the relays control the heat pump compressor, auxiliary heat, and the fan. Because of this change in switching logic, it is important to use Q7300C,D, H2003, H2011 Subbases when the T7300 is set for heat pump applications and the Q7300A,G, H2029 Subbases when the T7300 is set for conventional applications.

The T7200D Relay Logic is for conventional applications. The T7200E Relay Logic is for heat pump applications.

### T7200/T7300 and Conventional Thermostats

#### P+I Control

The T7200/T7300 microprocessor based control requires that the user understands temperature control and thermostat performance. A conventional electromechanical or electronic thermostat does not control temperature precisely at setpoint. Typically, there is an offset (droop) in the control point as the system load changes. This is a phenomenon that most people in the industry know and accept. Many factors contribute to offset including switch differential, thermal lag, overshoot, cycle rates and system load.

The thermostat microprocessor simultaneously gathers, compares and computes data. Using this data, it controls a wide variety of functions. The special proprietary algorithm

(program) in the thermostat eliminates the factors causing offset. This makes temperature control more accurate than the conventional electromechanical or electronic thermostats. The temperature control algorithm is called proportional plus integral (P+I) control.

The thermostat sensor, located on the thermostat or remote, senses the current space temperature. The proportional error is calculated by comparing the sensed temperature to the programmed setpoint. The deviation from the setpoint is the proportional error.

The thermostat also determines integral error, which is a deviation based on the length of error time. The sum of the two errors is the (P+I) error. The cycle rate used to reach and maintain the setpoint temperature is computed using the P+I. The addition of the integral error is what differentiates the thermostat from many other electronic and electromechanical

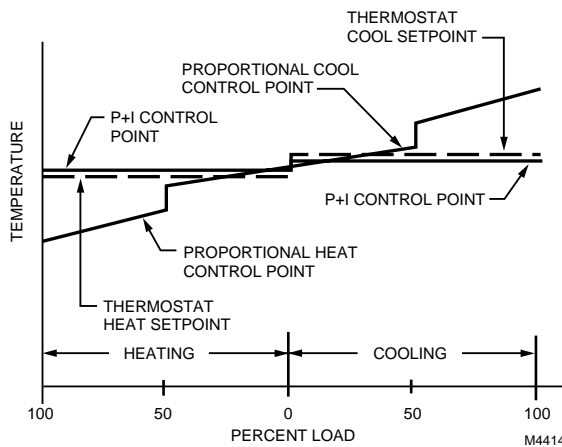

thermostats. See Fig. 17.

**Fig 17. Proportional temperature control versus P+I temperature control.**

## Equipment Protection

As part of the operational sequence, the T7200/T7300 microprocessor also incorporates minimum on and off times for all heating and cooling stages. Minimum on time is set in the installer setup number 32. Using the minimum on and off times assures that rapid cycling of equipment does not occur, which extends equipment life. Minimum on and off times are set in the Installer Setup.

## T7200/T7300 Thermostat Operation

### Startup

When power to the thermostat is turned on, a startup and initialization program begins. The startup occurs only on initial powerup. After total loss of power for an extended period, the current time and day may need to be set, but the user program is held. The initial default values are heating 68°F (20°C) and cooling 78°F (26°C) for the Occupied periods. Unoccupied default values are heating 55°F (13°C) and cooling 90°F (32°C).

**NOTE:** The thermostat controls to the Unoccupied default setpoints of 55°F (13°C) for heat and 90°F (32°C) for cool when no program is set.

## Occupied Operation

When the thermostat is operating in the Occupied period, the temperature is controlled to the occupied heat or cool setpoint. The normally open (A1) auxiliary relay contacts are closed and the normally closed (A3) auxiliary relay contacts are opened during the Occupied periods (if the subbase being used has this option). The fan operates as follows: fan selection can be set to On (always energized) or Auto (cycles with Y1 or W1).

## Unoccupied Operation

When the thermostat is operating in the Unoccupied period, the temperature is controlled to the Unoccupied heat or cool setpoint. The normally open (A1) relay contact is open and the normally closed (A3) relay contact is closed. The fan operates as follows: fan is always intermittent (cycles with Y1 or W1).

## Intelligent Recovery® Feature

Intelligent Recovery® feature is a Honeywell trademark for the way the thermostat controls the heating and cooling equipment during recovery from Unoccupied to Occupied setting. During recovery, the control point changes gradually rather than jumping from the energy saving setting to the comfort setting all at once.

When the Intelligent Recovery® feature is used in heating, the control point raises gradually, maximizing the use of the more economical first stage heat to bring the sensed temperature to the desired comfort setpoint. This minimizes using the typically more expensive second-stage heat.

The advantages are:

- Comfort setting is achieved at the programmed time and maintained regardless of weather conditions; occupants are comfortable.
- Drafts from low temperature discharge air are minimized during occupied periods.
- Thermostat automatically uses the more economical first stage of heat as the primary heat source during recovery, avoiding the use of the expensive second stage heating.
- Comfort and energy savings can be achieved in both heating and cooling.
- The thermostat reduces heat cycling, extending equipment life.

### Recovery from Unoccupied

The heating heat pump recovery ramp is 3°F (1.6°C) per hour, which differs from the 5°F (2.8°C) per hour for conventional systems. The 3°F helps the system use the economical heat pump more and the expensive auxiliary heat less. The cooling ramp is 5°F, the same as for conventional systems.

## Conventional System

The T7200 and T7300D,F Thermostats with Q7300A,G,H Subbases are designed for conventional heat/cool applications.

## Heat Pump Operation

The T7200E and T7300E,F Thermostats with Q7300C,D,H Subbases are used for heat pump applications. Additional information is required when configured for heat pump applications.

**O and B Terminals for Heating or Cooling Changeover**

The Q7300C controls heat pump changeover. The Q7300D,H is only used in a heat pump application when the heat pump controls the reversing valve changeover. See Table 13 for the operation of the O and B terminals on the Q7300C, H2003.

**O and B Terminals on a Conventional Subbase**

Conventional subbase O and B terminals can be used to drive dampers and valves. The O terminal is energized on a call for cooling and the B terminal is energized on a call for heating.

**Table 13. Operation of Q7300 O and B terminals.**

System Selection	O Terminal	B Terminal
Heat	Open	Closed
Cool	Closed	Open
Auto (Heat) <sup>a</sup>	Open	Closed
Auto (Cool) <sup>b</sup>	Closed	Open
Emergency Heat	Open	Closed
Off	c	c

- <sup>a</sup> When the system is calling for heat or is de-energized, but the last function was heat.
- <sup>b</sup> When the system is calling for cool or is de-energized, but the last function was cool.
- <sup>c</sup> When the last function was heating, the operation is the same as Auto (Heat). If the last function was cooling, the operation is the same as Auto (Cool).

**Fan Operation**

When the fan is set to On, the fan is energized continuously in the Occupied period. The Auto setting energizes the fan with the heating or cooling system. If the subbase is Q7300D, the fan cycles with Y1 and W1 during Unoccupied period.

**Emergency Heat**

When the system is set for Em Heat (on select T7300 Thermostats), the auxiliary heat is stage one and the compressor stages are locked off. The fan cycles with the auxiliary heat.

**Communicating Subbase**

Select T7300F Thermostats with the Q7300H Communicating Subbase are designed for conventional or heat pump applications in a LonWorks® network. The Q7300H Subbase allows remote access and the sharing of clock, schedule, setpoints, bypass and other system parameters in a LonWorks® network. See fig. 32 for a T7300F/Q7300H wiring layout in a LonWorks® network.

**GENERAL OPERATION INFORMATION**

**Cycle Rates**

The thermostat control algorithm maintains the temperature by cycling stages of heating or cooling to meet setpoint.

**Subbase Auxiliary Relay**

The Q7300 Auxiliary Relay output acts as a time-of-day switch to be used with an economizer minimum position control. The normally open (A1) auxiliary relay contacts are closed during the Occupied period and open during the Unoccupied period. The normally closed (A3) auxiliary relay contacts are open during the Occupied period and closed during the Unoccupied period. The contacts are in the normal state during recovery.

**Interfacing with Electromechanical Economizers (Subbases with Auxiliary Relay)**

Mechanical cooling is often used when outside temperatures are in the 50°F (10°C) to 60°F (16°C) range and humidity is below 50 percent. In central and northern climates, hundreds of hours fall into this temperature category. By permitting 80 to 100 percent outside air into the system, mechanical cooling may not be needed at all, particularly during Spring and Fall.

An economizer is used to take advantage of the outside air. The typical economizer consists of an outside air damper, motor, outdoor air changeover control and a minimum position potentiometer. The motor controls the dampers. Suitability of the outside air for cooling is determined by the outdoor air changeover control. The potentiometer is used for adjusting the minimum position of the economizer dampers, which provide a minimum amount of fresh air for ventilation.

The economizer reduces compressor run time, thereby saving energy and extending the compressor life. The drawback to using the economizer is that during the Unoccupied period, if there is no call for cooling or outdoor air is not suitable for free cooling, the economizer is controlled to minimum position. This position allows some percentage of outdoor air to enter the building, regardless of air suitability. The situation can cause the heating or cooling to run more often than if suitable outdoor air is permitted to enter the building.

The thermostat can take advantage of an economizer by connecting the auxiliary relay contacts (A1 and A2) of the subbase to control the economizer minimum position potentiometer. The contacts close during the Occupied period, allowing the economizer to operate normally. The contacts are open during the Unoccupied period, disabling the minimum position feature of the economizer. The open contacts cause the economizer to drive dampers fully closed instead of staying at minimum open position. This reduces the possibility of unsuitable outdoor air from entering the building, which lowers the internal load on the HVAC system and saves additional energy.

**Other Uses for the Auxiliary Relay**

Examples of other uses of the auxiliary relay are hot water heaters, lighting or baseboard heat. The additional loads are connected to the auxiliary relay contacts on the subbase. The contacts are rated for 1.6A at 30 Vac, but can be adapted to higher current applications with the use of an external relay and transformer. See Fig. 18.

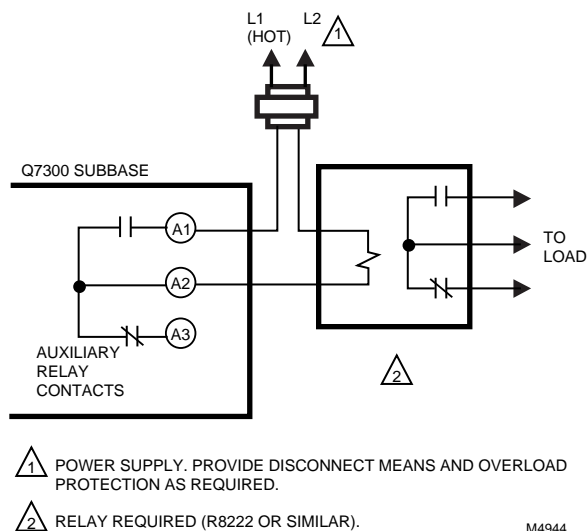

Fig. 18. Use of external relay and transformer for auxiliary loads greater than 1.6A.

## TROUBLESHOOTING GUIDE

Refer to Table 14 for troubleshooting information.

Table 14. Troubleshooting Information.

Symptom	Possible Cause	Action
Display will not come on.	Thermostat is not being powered.	<ul style="list-style-type: none"> <li>Check that X terminal is connected to the system transformer.</li> <li>Check for 24 Vac between X and R or RH terminals.                             <ul style="list-style-type: none"> <li>If missing 24 Vac:                                     <ul style="list-style-type: none"> <li>check if the circuit breaker is tripped; if so, reset the circuit breaker.</li> <li>check if the system fuse is blown; if so, replace the fuse.</li> <li>check if the power switch on the HVAC equipment is in the Off position; if so, set to the On position.</li> <li>check wiring between thermostat and HVAC equipment and replace any broken wires and tighten any loose connections.</li> </ul> </li> <li>If 24 Vac is present, proceed with troubleshooting.</li> </ul> </li> </ul>
Temperature display is incorrect.	Room temperature display has been reconfigured.	Enter Installer Setup number 37 and reconfigure the display.
	Thermostat is configured for °F or °C display.	Enter Installer Setup number 14 and reconfigure the display.
	Bad thermostat location.	Relocate the thermostat.
	Display shows two dashes and a degree sign.	Installer Setup 22 is set for remote sensing and the sensor is missing or the circuit is open or shorted.
Temperature settings will not change. (Example: Cannot set heating higher or cooling lower.)	Upper or lower temperature limits were reached.	Check the temperature setpoints: <ul style="list-style-type: none"> <li>Heating limits are 40 to 90°F (7 to 31°C)</li> <li>Cooling limits are 45 to 99°F (9 to 37°C)</li> </ul>
	The setpoint temperature range stops were configured.	Check Installer Setup number 34 and 35 and reconfigure the setpoint stops.
	Keypad is locked. When a locked key is pressed, LOC flashes on the LCD.	<ul style="list-style-type: none"> <li>Reset DIP switch 1 on back of thermostat to enable keypad.</li> <li>Enter Installer Setup number 25 or 40 and reconfigure keypad lockout level.</li> </ul>
Unable to configure Installer Setup	Installer Setup is locked out.	Reset the DIP switch 1 on back of thermostat to enable keypad.

(continued)

**Table 14. Troubleshooting Information (Continued).**

Symptom	Possible Cause	Action
Temperature settings change from original setting.	Trying to set heating and cooling setpoints too close together. There is a deadband in automatic changeover thermostat models. Example: cool setpoint=72, deadband=3, heat setpoint=68, changing heat setpoint to 70 will automatically change the cool setpoint to 73.	<ul style="list-style-type: none"> <li>• Check that the heating setpoint is lower than the cooling setpoint.</li> <li>• Check Installer Setup number 30 to identify the deadband between heating and cooling setpoints. Reconfigure if desired.</li> </ul>
Room temperature is out of control.	Remote temperature sensing is not working.	Checkout all remote sensors.
Heating will not come on.	No power to the thermostat.	<ul style="list-style-type: none"> <li>• Check that X terminal is connected to the system transformer.</li> <li>• Check for 24 Vac between X and R or RH terminals.                             <ul style="list-style-type: none"> <li>— If missing 24 Vac:                                     <ul style="list-style-type: none"> <li>— check if the circuit breaker is tripped; if so, reset the circuit breaker.</li> <li>— check if the system fuse is blown; if so, replace the fuse.</li> <li>— check if the system switch at the equipment is in the Off position; if so, set to On position.</li> <li>— check wiring between thermostat and HVAC equipment and replace any broken wires and tighten any loose connections.</li> </ul> </li> <li>— If 24 Vac is present, proceed with troubleshooting.</li> </ul> </li> </ul>
Heating will not come on (Continued).	Thermostat minimum off time is activated and wait indicator is displayed.	<ul style="list-style-type: none"> <li>• Wait up to five minutes for the system to respond.</li> <li>• Enter Installer Setup number 38. Reconfigure minimum off time (if required).</li> </ul>
	System selection is not set to Heat.	Set system selection to Heat.
Cooling will not come on.	No power to the thermostat.	<ul style="list-style-type: none"> <li>• Check that X terminal is connected to the system transformer</li> <li>• Check for 24 Vac between X and R or RC and Y terminals.                             <ul style="list-style-type: none"> <li>— If missing 24 Vac:                                     <ul style="list-style-type: none"> <li>— check if the circuit breaker is tripped; if so, reset the circuit breaker.</li> <li>— check if the system fuse is blown; if so, replace the fuse.</li> <li>— check if the system switch at the equipment is in the Off position; if so, set to the On position.</li> <li>— check wiring between thermostat and HVAC equipment and replace any broken wires and tighten any loose connections.</li> </ul> </li> <li>— If 24 Vac is present, proceed with troubleshooting.</li> </ul> </li> </ul>
	Thermostat minimum off time is activated and wait indicator is displayed.	<ul style="list-style-type: none"> <li>• Wait up to five minutes for the system to respond.</li> <li>• Enter Installer Setup number 33. Reconfigure minimum off-time (if required).</li> </ul>
	System selection is not set to Cool.	Set system selection to Cool.
System on indicator (flame=heat, snowflake=cool) is displayed, but no warm or cool air is coming from the registers.	Conventional heating equipment turns on the fan when the furnace has warmed up to a setpoint.	Wait one minute after seeing the on indicator and then check the registers.
	Heating or cooling equipment is not operating.	Verify operation of heating or cooling equipment in self-test.



## CROSS REFERENCE

All T7300/Q7300 Series 2000 models are different from the existing T7300/Q7300 T8611 and T8621 devices as summarized in Table 15.

**Fig. 15. Differences from existing T7300/Q7300 to new T7300/Q7300 Series 2000 devices.**

Feature/Function	Present T7300/Q7300, T8611, T8621 Families	T7300/Q7300 Series 2000 Family
System switching	Mechanical switch on Q7300 subbase.	Keyboard entry on T7300 thermostat.
Fan switching	Mechanical switch on Q7300 subbase.	Keyboard entry on T7300 thermostat.
Installer configuration	Field settings made via DIP switches on the back of the thermostat and subbase.	Field settings made through the T7300 thermostat keyboard.
Device color	Beige or Premier White® color.	Taupe or Premier White® color.

Refer to Table 16 for thermostat and subbase cross referencing information.

**Table 16. Thermostat and Subbase Cross Reference.**

Model Number	Description	Trade Replacement	Remarks
<b>Q7300A</b>	<b>Multistage conventional subbase; system switch: none; fan switch: none.</b>		
Q7300A1000	One-stage heat and one-stage cool.	T7300F2002/Q7300A2008	
Q7300A1018	Two-stage heat and two-stage cool.	T7300F2002/Q7300A2016	
Q7300A1034	One-stage heat and one-stage cool; Trane part no. BAS-0444.	T7300F2002/Q7300A2008	
Q7300A1042	Two-stage heat and two-stage cool; Trane part no. BAS-0445.	T7300F2002/Q7300A2016	
Q7300A1059	Two-stage heat and two-stage cool; Micrometl part no. 901-3.	T7300F2002/Q7300A2016	
Q7300A1067	Two-stage heat and two-stage cool; Carrier part no. HH93AX005.	T7300F2002/ Q7300A2016	Wiring differences (old=new): C=X, A1=A2, A2=A1.
Q7300A1075	One-stage heat and one-stage cool; gray color.	T7300F2002/Q7300A2008	
Q7300A1083	Two-stage heat and two-stage cool; gray color.	T7300F2002/Q7300A2016	
<b>Q7300B</b>	<b>Multistage conventional subbase; system switch: AUTO-COOL-OFF-HEAT; fan switch: AUTO-ON.</b>		
Q7300B1008	Two-stage heat and two-stage cool.	T7300F2010/Q7300A2016	
Q7300B1016	Two-stage heat and two-stage cool; Lennox part no. 81G6001.	T7300F2010/Q7300A2016	
Q7300B1024	Two-stage heat and two-stage cool; York part no. 025-27507.	T7300F2010/Q7300A2016	Wiring differences (old=new): B=X.
Q7300B1032	Two-stage heat and two-stage cool; Trane part no. BAS-0446.	T7300F2010/Q7300A2016	
Q7300B1040	Two-stage heat and two-stage cool; Carrier part no. HH93AX004.	T7300F2010/Q7300A2016	Wiring differences (old=new): C=X, A1=A2, A2=A1.
Q7300B1057	Two-stage heat and two-stage cool; Snyder General part no. 1520510.	T7300F2010/Q7300A2016	
Q7300B1065	Two-stage heat and two-stage cool; Snyder General part no. 490249B-04.	T7300F2010/Q7300A2016	
Q7300B1073	Two-stage heat and two-stage cool; Honeywell TRADELINE® model.	T7300F2010/Q7300A2016	Wiring differences (old=new): B=X.
Q7300B1081	Two-stage heat and two-stage cool; gray color.	T7300F2010/Q7300A2016	

(continued)

**Table 16. Thermostat and Subbase Cross Reference (Continued).**

Model Number	Description	Trade Replacement	Remarks
<b>Q7300C</b>	<b>Multistage heat pump subbase; system switch: AUTO-COOL-OFF-HEAT-EM HEAT; fan switch: AUTO-ON.</b>		
Q7300C1006	Single-stage heat pump with auxiliary heat (2H/1C).	T7300F2010/ Q7300C2004	Wiring differences (old=new): W1=W2, B=A3.
Q7300C1014	Two-stage heat pump with auxiliary heat (3H/2C).	T7300F2010/Q7300C2012	Wiring differences (old=new): B=A3.
Q7300C1022	Two-stage heat pump with auxiliary heat (3H/2C); Lennox part no. 81G6901.	T7300F2010/Q7300C2012	Wiring differences (old=new): B=A3.
Q7300C1030	Two-stage heat pump with auxiliary heat (3H/2C); York part no. 025-27508.	T7300F2010/Q7300C2012	Wiring differences (old=new): B=X, X=E.
Q7300C1048	Single-stage heat pump with auxiliary heat (2H/1C); Trane part no. BAS-0447.	T7300F2010/Q7300C2004	Wiring differences (old=new): W1=W2, B=A3.
Q7300C1055	Two-stage heat pump with auxiliary heat (3H/2C); Trane part no. BAS-0048.	T7300F2010/Q7300C2012	Wiring differences (old=new): B=A3.
Q7300C1063	Single-stage heat pump with auxiliary heat (2H/1C); Micrometl part no. 901-24.	T7300F2010/Q7300C2004	Wiring differences (old=new): W1=W2, B=A3.
Q7300C1071	Two-stage heat pump with auxiliary heat (3H/2C).	T7300F2010/Q7300C2012	Wiring differences (old=new): B=A3.
Q7300C1089	Two-stage heat pump with auxiliary heat (3H/2C); Honeywell TRADELINE® model.	T7300F2010/Q7300C2012	Wiring differences (old=new): B=X, X=E.
Q7300C1097	Single-stage heat pump with auxiliary heat (2H/1C).	T7300F2010/Q7300C2004	Wiring differences (old=new): W1=W2, B=A3.
Q7300C1105	Two-stage heat pump with auxiliary heat (3H/2C); gray color.	T7300F2010/Q7300C2012	Wiring differences (old=new): B=A3.
<b>Q7300D</b>	<b>Multistage heat pump subbase; does not include O or B terminals; system switch: AUTO-COOL-OFF-HEAT-EM HEAT; fan switch: AUTO-ON.</b>		
Q7300D1004	Two-stage heat pump with auxiliary heat (3H/2C); Carrier part no. HH93AX002.	T7300F2010/ Q7300D2002	Wiring differences (old=new): C=X, A1=A2, A2=A1.
Q7300D1012	Single-stage heat pump with auxiliary heat (2H/1C); Carrier part no. HH93AX003.	T7300F2010/ Q7300D2002	Wiring differences (old=new): C=X, A1=A2, A2=A1.
Q7300D1020	Two-stage heat pump with auxiliary heat (3H/2C); York part no. 025-27724-000.	T7300F2010/ Q7300D2002	Wiring differences (old=new): B=X, X=X1.
Q7300D1038	Two-stage heat pump with auxiliary heat (3H/2C).	T7300F2010/Q7300D2002	
Q7300D1046	Two-stage heat pump with auxiliary heat (3H/2C); Lennox part no. 13H7601.	T7300F2010/Q7300D2002	
Q7300D1053	Single-stage heat pump with auxiliary heat (2H/1C).	T7300F2010/Q7300D2010	
Q7300D1061	Two-stage heat pump with auxiliary heat (3H/2C); Honeywell TRADELINE® model.	T7300F2010/Q7300D2002	Wiring differences (old=new): B=X, X=X1.
Q7300D1079	Two-stage heat pump with auxiliary heat (3H/2C); gray color.	T7300F2010/Q7300D2002	
Q7300D1087	Single-stage heat pump with auxiliary heat (2H/1C); gray color.	T7300F2010/Q7300D2002	
<b>Q7300E</b>	<b>Multistage conventional subbase; system switch: none; fan switch: AUTO-ON.</b>		
Q7300E1001	Two-stage heat and two-stage cool.	T7300F2010/Q7300A2016	
Q7300E1019	Two-stage heat and two-stage cool; gray color.	T7300F2010/Q7300A2016	

(continued)

Table 16. Thermostat and Subbase Cross Reference (Continued).

Model Number	Description	Trade Replacement	Remarks
<b>Q7300F</b>	<b>Multistage heat pump subbase; system switch: none; fan switch: none.</b>		
Q7300F1009	Single-stage heat pump with auxiliary heat (2H/1C).	T7300F2002/Q7300C2004	
Q7300F1017	Two-stage heat pump with auxiliary heat (3H/2C).	T7300F2002/Q7300C2012	
Q7300F1025	Single-stage heat pump with auxiliary heat (2H/1C); gray color.	T7300F2002/Q7300C2004	
Q7300F1033	Two-stage heat pump with auxiliary heat (3H/2C); gray color.	T7300F2002/Q7300C2012	
Q7300F1041	Single-stage heat pump with auxiliary heat (2H/1C); Carrier part no. HH93AX006.	T7300F2002/Q7300C2004	
<b>Q7300G</b>	<b>Conventional heat pump subbase; system switch: AUTO-COOL-OFF-HEAT; fan switch: none.</b>		
Q7300G1007	One-stage heat and three-stage cool.	T7300F2010/Q7300G2005	
Q7300G1015	One-stage heat and three-stage cool; gray color.	T7300F2010/Q7300G2005	
<b>Q7300L</b>	<b>Multistage conventional subbase used with ML984A and V5013; system switch: none; fan switch: AUTO-ON.</b>		
Q7300L1006	Two-stage heat and one-stage cool.	T7300F2010/Q7300L2004	
Q7300L1014	Two-stage heat and one-stage cool; gray color.	T7300F2010/Q7300L2004	
<b>T7200A</b>	<b>One-stage heat and one-stage cool conventional thermostat.</b>		
T7200A1006	Honeywell logo.	T7200D2008	
T7200A1022	Honeywell logo with international faceplate.	T7200D2008	
<b>T7200B</b>	<b>One-stage heat and one-stage cool heat pump thermostat.</b>		
T7200B1004	Honeywell logo.	T7200E2005	
T7200B1012	Mammoth logo; part no. 71116701.	T7200E2005	
T7200B1020	Carrier logo; part no. HH07AX010A.	T7200E2005	
<b>T7300A</b>	<b>Multistage conventional and heat pump thermostat.</b>		
T7300A1005	Honeywell logo.		See subbase description for replacement information.
T7300A1013	York logo; part no. 025-27506.		See subbase description for replacement information.
T7300A1021	Lennox logo; part no. 81G5901.		See subbase description for replacement information.
T7300A1039	Trane logo; part no. THT-0608.		See subbase description for replacement information.
T7300A1047	Micrometl logo; part no. 901-114.		See subbase description for replacement information.
T7300A1054	Honeywell logo with international faceplate.		See subbase description for replacement information.
T7300A1062	Carrier logo; part no. HH07AX005.		See subbase description for replacement information.

(continued)

Table 16. Thermostat and Subbase Cross Reference (Continued).

Model Number	Description	Trade Replacement	Remarks
T7300A1070	Roca logo with international faceplate.		See subbase description for replacement information.
T7300A1088	Honeywell logo with Spanish faceplate.		See subbase description for replacement information.
T7300A1104	Honeywell logo; Premier White® color.		See subbase description for replacement information.
T7300A1120	Luxaire logo; part no. 6ET04700224A.		See subbase description for replacement information.
<b>T7300B</b>	<b>Multistage conventional and heat pump thermostat with 3-HOUR OVERRIDE key on cover.</b>		
T7300B1003	Honeywell logo.		See subbase description for replacement information.
T7300B1011	Climate Control logo; part no. 490249B-05.		See subbase description for replacement information.
T7300B1029	McQuay logo; part no. 490249B-06.		See subbase description for replacement information.
T7300B1037	Arcoaire logo; part no. 1506746.		See subbase description for replacement information.
T7300B1045	Comfortmaker logo; part no. 1505746.		See subbase description for replacement information.
T7300B1052	Honeywell logo; Premier White® color.		See subbase description for replacement information.
<b>T7300C</b>	<b>Multistage conventional and heat pump thermostat with limited access cover.</b>		
T7300C1001	Honeywell logo.		See subbase description for replacement information.
T7300C1019	Honeywell logo; Premier White® color.		See subbase description for replacement information.
<b>T8611M</b>	<b>Three-stage heat and two-stage cool heat pump thermostat; System : EM HEAT-HEAT-OFF-AUTO-COOL; fan switch: ON-AUTO.</b>		
T8611M7008	Honeywell logo; TRADELINE® model.	T7300E2004/Q7300C2020	Wiring differences (old=new): C=X, X4 to X field-installed jumper required.
T8611M7040	Honeywell logo; TRADELINE® model; remote sensor capability.	T7300E2020/Q7300C2020	Wiring differences (old=new): C=X, X4 to X field-installed jumper required; purchase new remote 2-wire sensors separately.

(continued)

Table 16. Thermostat and Subbase Cross Reference (Continued).

Model Number	Description	Trade Replacement	Remarks
T8611M7057	Honeywell logo; TRADELINE® Premier White® color model; remote sensor capability.	T7300E2020/Q7300C2020	Wiring differences (old=new): C=X, X4 to X field-installed jumper required; purchase new remote 2-wire sensors separately.
T8611M7065	Trol-A-Temp® by Honeywell logo; Premier White® color.	None	See Trol-A-Temp® representative for replacement.
T8611M7073	Trane logo; white styling; part no. TAYSTAT502.	T7300E2004/Q7300C2020	Wiring differences (old=new): B=X, F=X1, X2=E, Y1=Y, X4 to X field-installed jumper required.
<b>T8621A</b>	<b>One-stage heat and one-stage cool conventional thermostat; two transformer capability; system switch: HEAT-AUTO-COOL-OFF; fan switch: ON-AUTO.</b>		
T8621A7002	Honeywell logo; TRADELINE® model.	T7300D2007/Q7300A2008	Wiring differences (old=new): C=X.
T8621A7010	Honeywell logo; Canadian TRADELINE® model.	T7300D2007/Q7300A2008	Wiring differences (old=new): C=X.
T8621A7028	Amana logo.	T7300D2007/Q7300A2008	Wiring differences (old=new): C=X.
T8621A7036	Trane logo; part no. THT-0605, order no. 13510323-15-7.	T7300D2007/Q7300A2008	Wiring differences (old=new): C=X.
T8621A7044	Honeywell logo; TRADELINE® model; remote sensor capability.	T7300D2049/Q7300A2008	Wiring differences (old=new): C=X; purchase new remote 2-wire sensors separately.
T8621A7051	McQuay logo; Premier White® color; part no. 067114201.	T7300D2007/Q7300A2008	Wiring differences (old=new): C=X.
T8621A7069	Honeywell logo; TRADELINE® Premier White® color model; remote sensor capability.	T7300D2049/Q7300A2008	Wiring differences (old=new): C=X; purchase new remote 2-wire sensors separately.
<b>T8621B</b>	<b>One-stage heat and two-stage cool conventional thermostat; one transformer capability; System : HEAT-AUTO-COOL-OFF; fan switch: ON-AUTO</b>		
T8621B7000	Carrier logo; LOW and HIGH SPEED LEDs; used on multispeed equipment; part no. HH07AX011.	T7300D2007/Q7300A2008	Wiring differences (old=new): L=X1; X4 to X and RC to RH field-installed jumper required.
T8621B7018	BDP multi-logo; LOW and HIGH SPEED LEDs; used on multispeed equipment; part no. HH07AX012.	T7300D2007/Q7300A2008	Wiring differences (old=new): L=X1; X4 to X and RC to RH field-installed jumper required.
T8621B7026	Honeywell logo; TRADELINE® model; Premier White® color; direct replacement for T8621B7000 and T8621B7018.	T7300D2007/Q7300A2008	Wiring differences (old=new): L=X1; X4 to X and RC to RH field-installed jumper required.
<b>T8621C</b>	<b>Two-stage heat and one-stage cool conventional thermostat; two transformer capability; system switch: HEAT-AUTO-COOL-OFF; fan switch: ON-AUTO.</b>		
T8621C7008	Honeywell logo; TRADELINE® model.	T7300D2007/Q7300A2040	Wiring differences (old=new): C=X.
T8621C7016	Honeywell logo; Canadian TRADELINE® model.	T7300D2007/Q7300A2040	Wiring differences (old=new): C=X.

(continued)

Table 16. Thermostat and Subbase Cross Reference (Continued).

Model Number	Description	Trade Replacement	Remarks
T8621C7032	Trane logo; system switch: HEAT-OFF-COOL; one transformer; dual fuel switch; part no. TAYSTAT302.	T7300D2007/Q7300A2040	Wiring differences (old=new): B=X; RC to RH field-installed jumper required.
<b>T8621D</b>	<b>Two-stage heat and two-stage cool conventional thermostat; two transformer capability; system switch: HEAT-AUTO-COOL-OFF; fan: ON-AUTO.</b>		
T8621D7006	Honeywell logo; TRADELINE® model.	T7300D2007/Q7300A2008	Wiring differences (old=new): C=X.
T8621D7014	Honeywell logo; Canadian TRADELINE® model.	T7300D2007/Q7300A2008	Wiring differences (old=new): C=X.
T8621D7022	Honeywell logo; TRADELINE® model; system switch: HEAT-OFF-COOL; dual fuel switch; O and B terminals.	T7300D2007/Q7300A2057	Wiring differences (old=new): C=X.
T8621D7030	Trane logo; part no. THT-0607; order no. 13510323-17-7.	T7300D2007/ Q7300A2008	Wiring differences (old=new): C=X.
T8621D7048	BDP multi-logo.	T7300D2007/Q7300A2008	Wiring differences (old=new): C=X.
T8621D7055	Lennox logo; one transformer capability; part no. 27H2901.	T7300D2007/Q7300A2008	Wiring differences (old=new): C=X. RC to RH field-installed jumper required.
T8621D7063	Trol-A-Temp® by Honeywell logo; system switch: HEAT-OFF-COOL; O and B terminals.	None	Wiring differences (old=new): C=X; see Trol-A-Temp® representative for replacement.
T8621D7071	Trol-A-Temp® by Honeywell logo; no system or fan switching.	None	See Trol-A-Temp® representative for replacement.
T8621D7089	Carrier logo; part no. HH641-103.	T7300D2007/Q7300A2008	Wiring differences (old=new): C=X.
T8621D7097	Honeywell logo; TRADELINE® model; remote sensor capability.	T7300D2007/Q7300A2008	Wiring differences (old=new): C=X; purchase new remote 2-wire sensors separately.
T8621D7105	Friedrich logo; L terminal; extra switch for louver control; part no. 616-789-01.	None	See OEM for replacement information.
T8621D7113	Honeywell Logo; Canadian TRADELINE® Premier White® color model.	T7300D2007/Q7300A2008	Wiring differences (old=new): C=X.
T8621D7139	McQuay logo; Premier White® color; part no. 067114301.	T7300D2007/Q7300A2008	Wiring differences (old=new): C=X.
T8621D7147	Honeywell logo; TRADELINE® Premier White® color model; remote sensor capability.	T7300D2007/Q7300A2008	Wiring differences (old=new): C=X.; purchase new remote 2-wire sensors separately.
T8621D7154	Carrier Weathermaker logo; part no. H07AX014.	T7300D2007/Q7300A2008	Wiring differences (old=new): C=X.
T8621D7162	Carrier Zone Perfect logo; part no. HH07AX015.	T7300D2007/Q7300A2008	Wiring differences (old=new): C=X.
T8621D7170	Honeywell logo; TRADELINE® Premier White® color model.	T7300D2007/Q7300A2008	Wiring differences (old=new): C=X.
T8621D7188	Carrier logo; Premier White® color; part no. HH07AT014W.	T7300D2007/Q7300A2008	Wiring differences (old=new): C=X.

(continued)

**Table 16. Thermostat and Subbase Cross Reference (Continued).**

Model Number	Description	Trade Replacement	Remarks
<b>T8621E</b>	<b>Two-stage cool only model with louver control; system switch: COOL-OFF; fan switch: ON-AUTO.</b>		
T8621E7003	Friedrich logo; L terminal; extra switch for louver control; part no. 616-789-00.	None	See OEM for replacement information.
<b>Y7200</b>	<b>One-stage heat and one-stage cool heat pump thermostat.</b>		
Y7200B1009	Contains six T7200B1020 Thermostats; Carrier part no. 50QE90016101.	T7200E2005	Wiring differences (old=new): C=X.
<b>Y7300</b>	<b>Multistage T7300 thermostat and Q7300 subbase.</b>		
Y7300A1000	Contains one T7300A1047 Thermostat and one Q7300A1059 Subbase; Micrometl part no. 1060A-100.	T7300F2002/Q7300A2016	Wiring differences (old=new): B=X.
Y7300A1018	Contains one T7300A1062 Thermostat and one Q7300F1041 Subbase; Carrier part no. 50QE90028101.	T7300F2002/Q7300C2004	
Y7300B1008	Contains one T7300A1013 Thermostat and one Q7300B1024 Subbase; York part no. 025-27504; York model no. 2ET04700224.	T7300F2010/Q7300A2016	
Y7300B1016	Contains one T7300B1045 Thermostat and one Q7300B1057 Subbase; Comfortmaker part no. 1505748.	T7300F2010/Q7300A2016	
Y7300B1024	Contains one T7300B1037 Thermostat and one Q7300B1057 Subbase; Arcoaire part no. 1506748.	T7300F2010/Q7300A2016	
Y7300C1006	Contains one T7300A1013 Thermostat and one Q7300C1030 Subbase; York part no. 025-27505; York model no. 2ET04700324.	T7300F2010/Q7300C2012	Wiring differences (old=new): B=X, X=E.
Y7300C1014	Contains one T7300A1047 Thermostat and one Q7300C1063 Subbase; Micrometl part no. 1060A-200.	T7300F2010/Q7300C2004	Wiring differences (old=new): W1=W2, B=A3.
Y7300D1004	Contains one T7300A1013 Thermostat and one Q7300D1020 Subbase; York part no. 025-27724-000; York model no. 2ET04700424A.	T7300F2010/Q7300D2002	Wiring differences (old=new): B=X, X=L1.

**T7300/Q7300 Series 2000 Cross Reference.**

Model Number	Figure Number	Description	Trade Replacement	Remarks
<b>Q7300A</b>	<b>Multistage conventional subbase used with T7300D or F Thermostat.</b>			
Q7300A2008	21	One-stage heat and one-stage cool; TRADELINE® model; remote sensor capability; taupe color.	Q7300A2008	Direct replacement for T8621A Thermostats.
Q7300A2016	24	Two-stage heat and two-stage cool; TRADELINE® model; remote sensor and discharge air sensor capability; taupe color.	Q7300A2016	
Q7300A2040	22	Two-stage heat and one-stage cool; TRADELINE® model; taupe color.	Q7300A2040	Direct replacement for T8621C Thermostats.
Q7300A2057	23	Two-stage heat and two-stage cool; TRADELINE® model; O and B terminals; taupe color.	Q7300A2057	Direct replacement for T8621D7022 Thermostat.
<b>Q7300C</b>	<b>Multistage heat pump subbase used with T7300E or F Thermostat.</b>			
Q7300C2004	25	Single-stage heat pump with auxiliary heat (2H/1C); TRADELINE® model; remote sensor and discharge air sensor capability; taupe color	Q7300C2004	

(continued)

**Table 16. Thermostat and Subbase Cross Reference (Continued).**

Model Number	Description	Trade Replacement	Remarks
Y7300C1006	Contains one T7300A1013 Thermostat and one Q7300C1030 Subbase; York part no. 025-27505; York model no. 2ET04700324.	T7300F2010/Q7300C2012	Wiring differences (old=new): B=X, X=E.
Y7300C1014	Contains one T7300A1047 Thermostat and one Q7300C1063 Subbase; Micrometl part no. 1060A-200.	T7300F2010/Q7300C2004	Wiring differences (old=new): W1=W2, B=A3.
Y7300D1004	Contains one T7300A1013 Thermostat and one Q7300D1020 Subbase; York part no. 025-27724-000; York model no. 2ET04700424A.	T7300F2010/Q7300D2002	Wiring differences (old=new): B=X, X=L1.

**T7300/Q7300 Series 2000 Cross Reference.**

Model Number	Figure Number	Description	Trade Replacement	Remarks
<b>Q7300A</b> Multistage conventional subbase used with T7300D or F Thermostat.				
Q7300A2008	21	One-stage heat and one-stage cool; TRADELINE® model; remote sensor capability; taupe color.	Q7300A2008	Direct replacement for T8621A Thermostats.
Q7300A2016	24	Two-stage heat and two-stage cool; TRADELINE® model; remote sensor and discharge air sensor capability; taupe color.	Q7300A2016	
Q7300A2040	22	Two-stage heat and one-stage cool; TRADELINE® model; taupe color.	Q7300A2040	Direct replacement for T8621C Thermostats.
Q7300A2057	23	Two-stage heat and two-stage cool; TRADELINE® model; O and B terminals; taupe color.	Q7300A2057	Direct replacement for T8621D7022 Thermostat.
<b>Q7300C</b> Multistage heat pump subbase used with T7300E or F Thermostat.				
Q7300C2004	25	Single-stage heat pump with auxiliary heat (2H/1C); TRADELINE® model; remote sensor and discharge air sensor capability; taupe color.	Q7300C2004	
Q7300C2012	26	Two-stage heat pump with auxiliary heat (3H/2C); TRADELINE® model; remote sensor and discharge air sensor capability; taupe color.	Q7300C2012	
Q7300C2053	27	Two-stage heat pump with auxiliary heat (3H/2C); TRADELINE® model; CHECK and FAIL LEDs; taupe color.	Q7300C2020	Direct replacement for T8611M Thermostats.
<b>Q7300D</b> Multistage heat pump subbase used with T7300E or F Thermostat.				
Q7300D2002	28	Two-stage heat pump with auxiliary heat (3H/2C); TRADELINE® model; remote sensor and discharge air sensor capability; taupe color.	Q7300D2002	
Q7300D2010	29	Single-stage heat pump with auxiliary heat (2H/1C); TRADELINE® model; remote sensor and discharge air sensor capability; taupe color.	Q7300D2010	
<b>Q7300G</b> Multistage conventional subbase used with T7300D or F Thermostat.				
Q7300G2005	30	Three-stage heat and three-stage cool (3H/3C); TRADELINE® model; remote sensor and discharge air sensor capability; taupe color.	Q7300G2005	

(continued)



T7300/Q7300 Series 2000 Cross Reference (Continued).

Model Number	Figure Number	Description	Trade Replacement	Remarks
<b>Q7300L</b>	<b>Multistage subbase used with ML7984A, V5011, V5013 and T7300D or F Thermostat.</b>			
Q7300L2004	31, 32	Two-stage heat and one-stage cool (2H/1C); TRADELINE® model; multispeed fan; contacts for damper control relay and pump interlock relay; HEAT and COOL LEDs; remote sensor and discharge air sensor capability; taupe color.	Q7300L2004	Direct replacement for Q7300L1006 and Q7300L1014 Subbases.
<b>T7200D</b>	<b>One-stage heat and one-stage cool conventional thermostat.</b>			
T7200D2008	19	Honeywell logo; no system or fan settings.	T7200D2008	Direct replacement for T7200A Thermostats.
<b>T7200E</b>	<b>One-stage heat and one-stage cool heat pump thermostat.</b>			
T7200E2005	20	Honeywell logo; no system or fan settings.	T7200E2005	Direct replacement for T7200B Thermostats.
<b>T7300D</b>	<b>Multistage conventional thermostat used with Q7300A,G, or L Subbase.</b>			
T7300D2007	Refer to subbase	Honeywell logo; TRADELINE® model; remote sensor capability; system settings: Heat-Off-Cool-Auto; taupe color.	T7300D2007	Direct replacement for T8621 Thermostats.
<b>T7300E</b>	<b>Multistage heat pump thermostat used with Q7300C or D Subbase.</b>			
T7300E2020	Refer to subbase	Honeywell logo; TRADELINE® model; remote sensor capability; system settings: Em Heat-Heat-Off-Cool-Auto; taupe color.	T7300E2020	Direct replacement for T8611M Thermostats.
<b>T7300F</b>	<b>Multistage thermostat for heat pump (Q7300C or D Subbase) and conventional (Q7300A,G or L Subbase) applications.</b>			
T7300F2002	Refer to subbase	Honeywell logo; SUPER TRADELINE® model; remote sensor and discharge air sensor capability; no system or fan settings; taupe color.	T7300F2002	
T7300F2010	Refer to subbase	Honeywell logo; SUPER TRADELINE® model; remote sensor and discharge air sensor capability; system settings: configurable; fan settings: Auto-On; taupe color.	T7300F2010	

WIRING DIAGRAMS (FIG. 19-33)

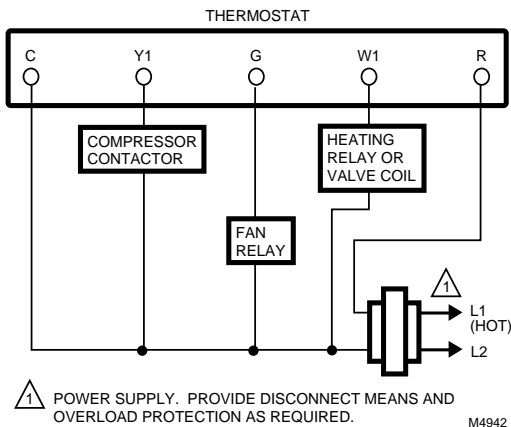

Fig. 19. T7200D with wallplate.

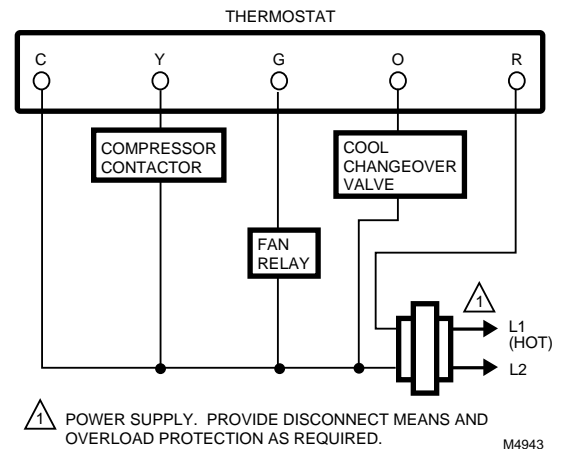
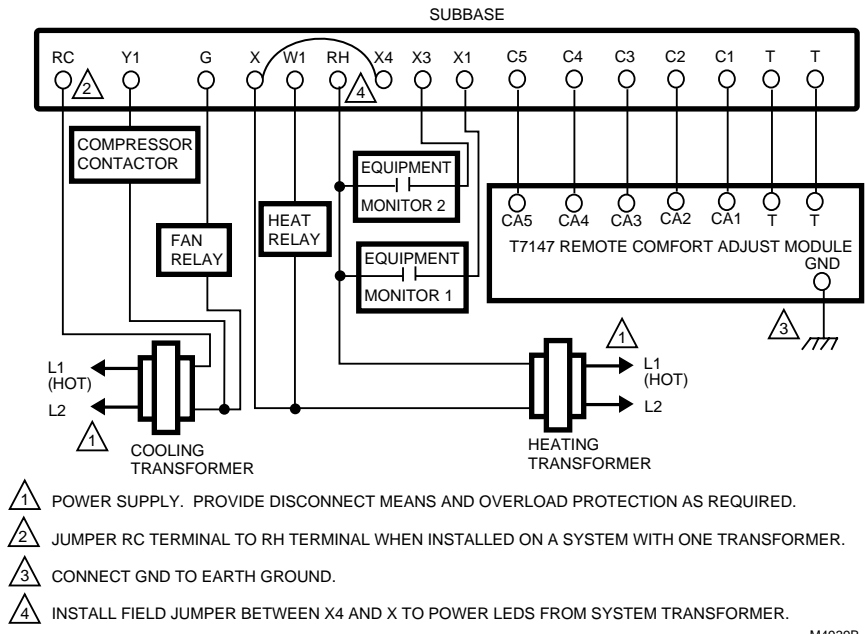
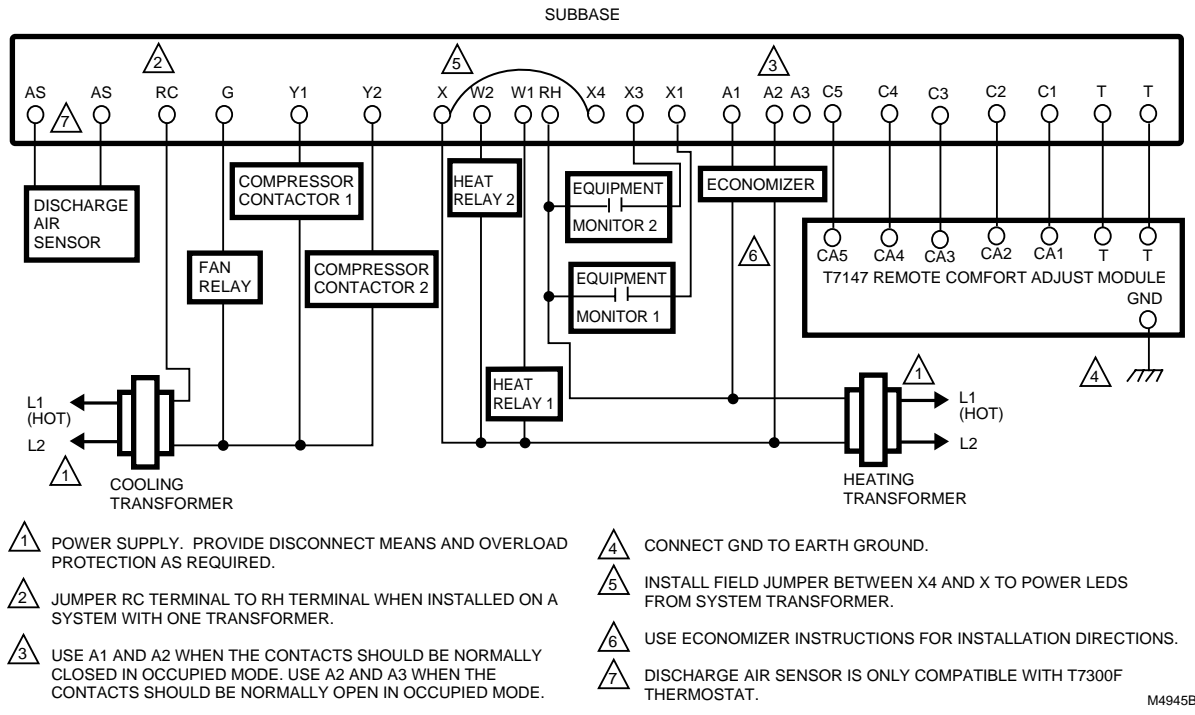

Fig. 20. T7200E with one-stage heat pump system.



**Fig. 21. Typical hookup of T7300D,F/Q7300A2008 in one-stage heat and one-stage cool conventional system with two transformers.**



**Fig. 22. Typical hookup of T7300D,F/Q7300A2016 in two-stage heat and two-stage cool conventional system with two transformers.**

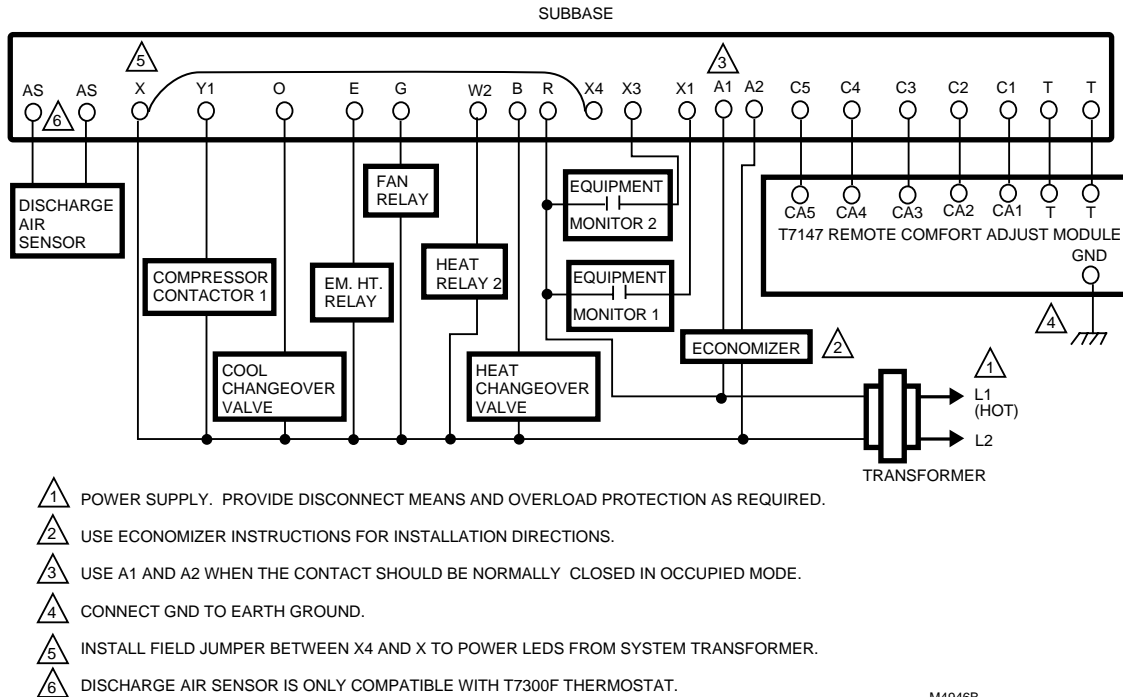

Fig. 23. Typical hookup of T7300E,F/Q7300C2004 in two-stage heat and one-stage cool heat pump system.

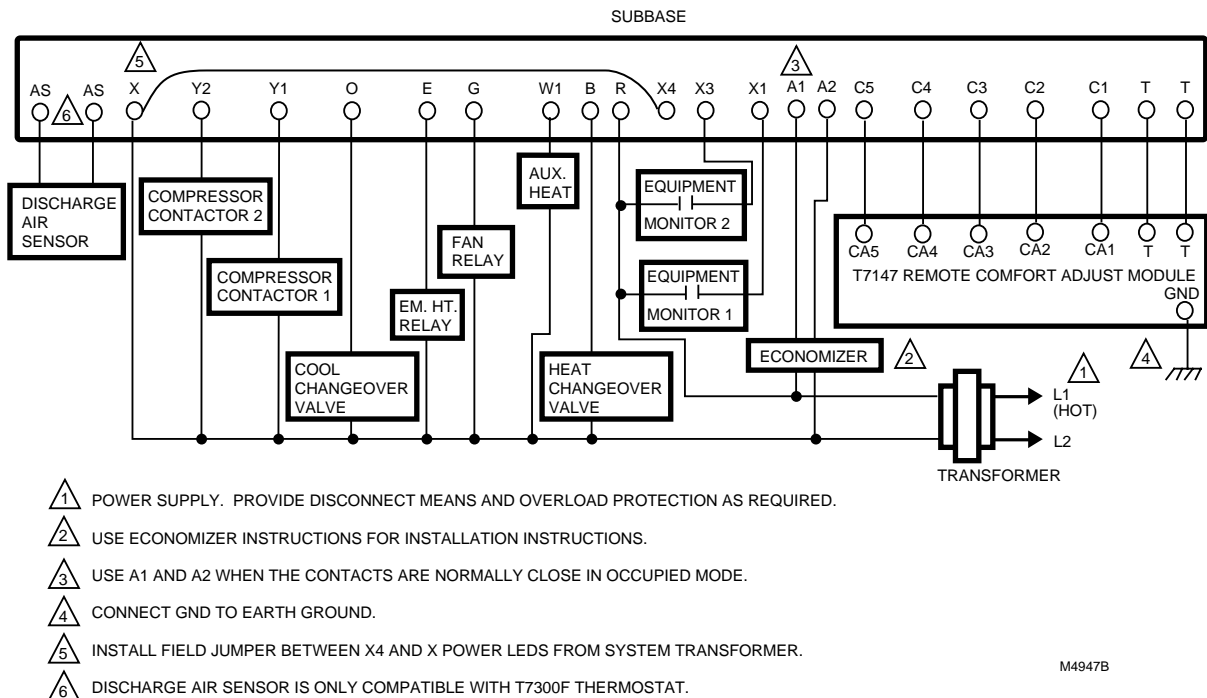
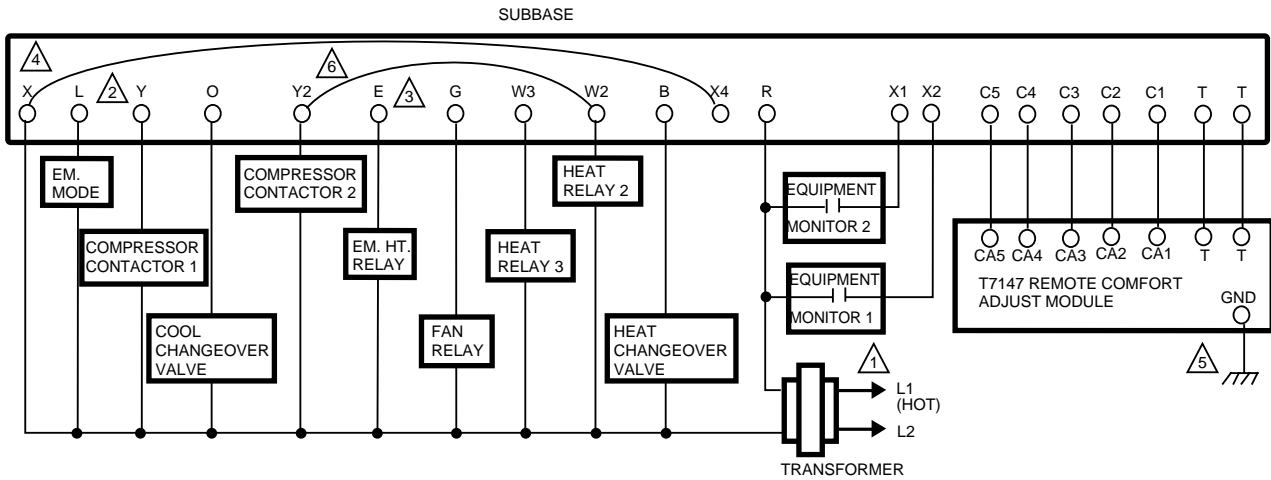

Fig. 24. Typical hookup of T7300E,F/Q7300C2012 in three-stage heat and two-stage cool heat pump system.



- 1 POWER SUPPLY. PROVIDE DISCONNECT MEANS AND OVERLOAD PROTECTION AS REQUIRED.
- 2 EM. MODE IS ON CONTINUOUSLY IN EMERGENCY HEAT MODE. 24 VAC ARE PRESENT DURING EMERGENCY HEAT MODE.
- 3 EM. HT. RELAY CYCLES IN EMERGENCY HEAT MODE.
- 4 INSTALL FIELD JUMPER BETWEEN X4 AND X POWER LEDS FROM SYSTEM TRANSFORMER.
- 5 CONNECT GND TO EARTH GROUND.
- 6 JUMPER W2 TO Y2 FOR SECOND COMPRESSOR. W3 IS AUXILIARY HEAT.

M4940B

**Fig. 25. Typical hookup of T7300E,F/Q7300C2053 in three-stage heat and two-stage cool heat pump system. This thermostat and subbase can replace the T8611M.**

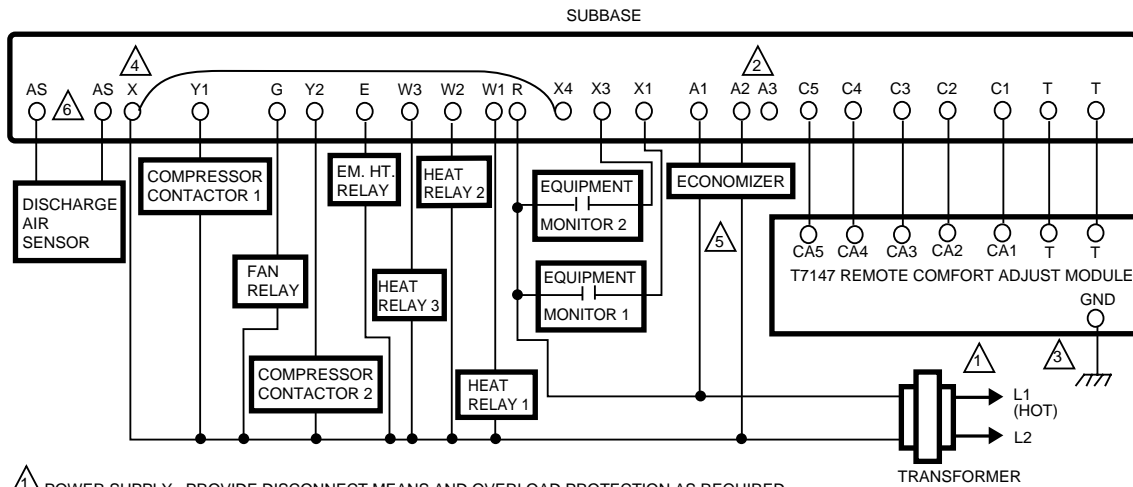

- 1 POWER SUPPLY. PROVIDE DISCONNECT MEANS AND OVERLOAD PROTECTION AS REQUIRED.
- 2 USE A1 AND A2 WHEN THE CONTACTS SHOULD BE NORMALLY CLOSED IN OCCUPIED MODE. USE A2 AND A3 WHEN THE CONTACTS SHOULD BE NORMALLY OPEN IN OCCUPIED MODE.
- 3 CONNECT GND TO EARTH GROUND.
- 4 INSTALL FIELD JUMPER BETWEEN X4 AND X TO POWER LEDS FROM SYSTEM TRANSFORMER.
- 5 USE ECONOMIZER INSTRUCTIONS FOR INSTALLATION DIRECTIONS.
- 6 DISCHARGE AIR SENSOR IS ONLY COMPATIBLE WITH T7300F THERMOSTAT.

M4948B

**Fig. 26. Typical hookup of T7300E,F/Q7300D2002 in three-stage heat and two-stage cool heat pump system.**

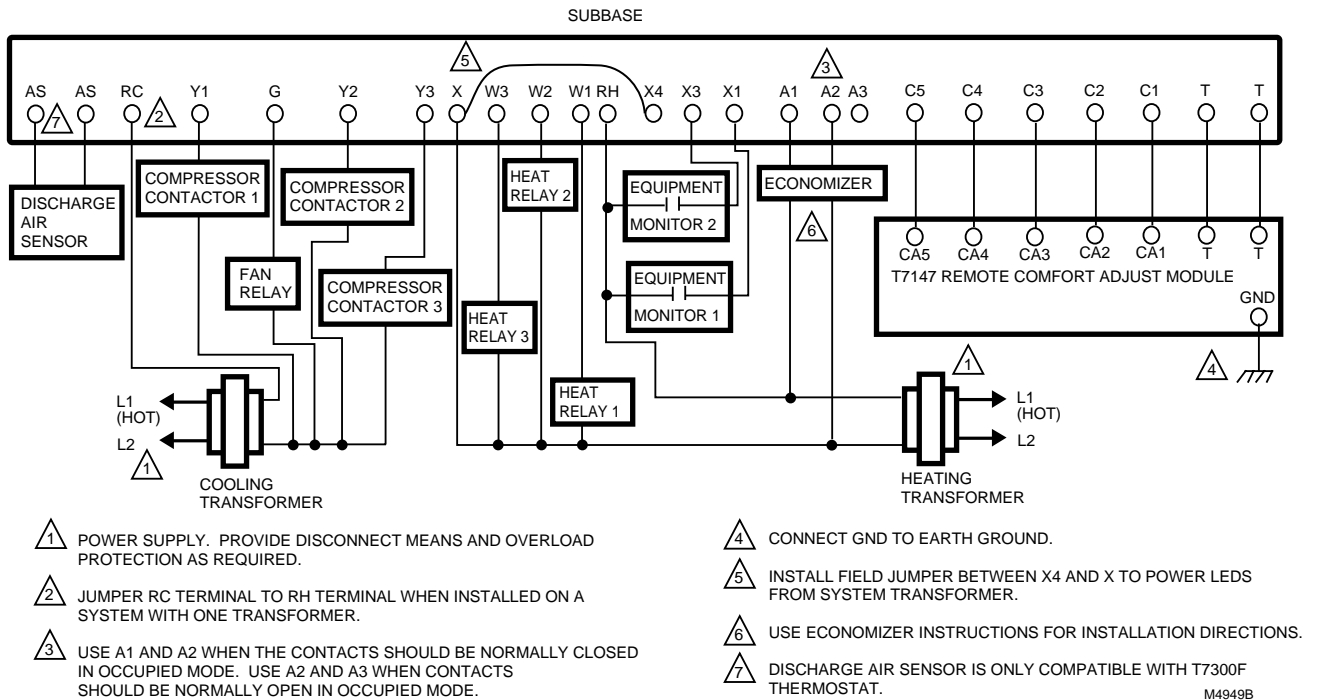

Fig. 27. Typical hookup of T7300D,F/Q7300G2005 in three-stage heat and three-stage cool conventional system.

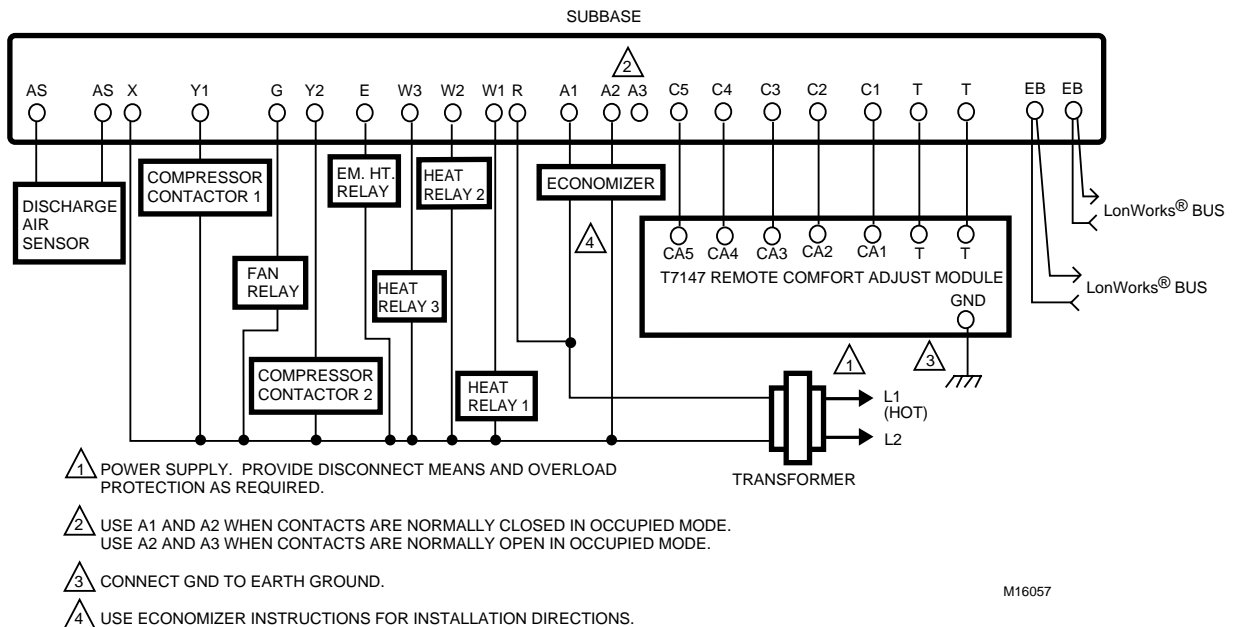
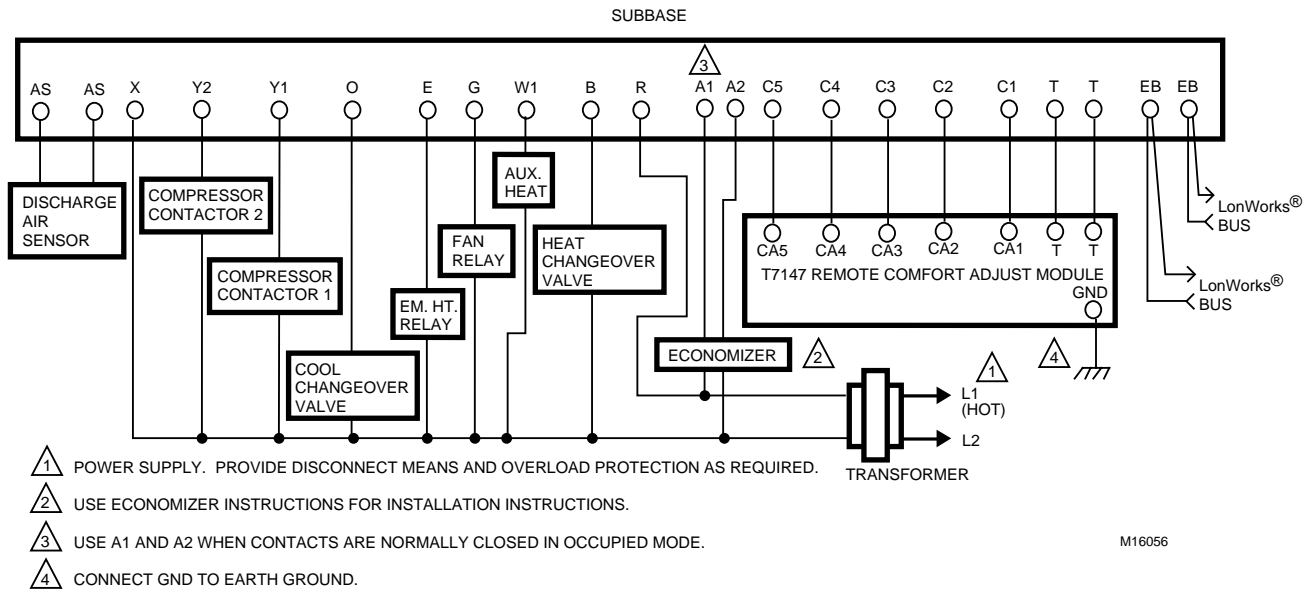
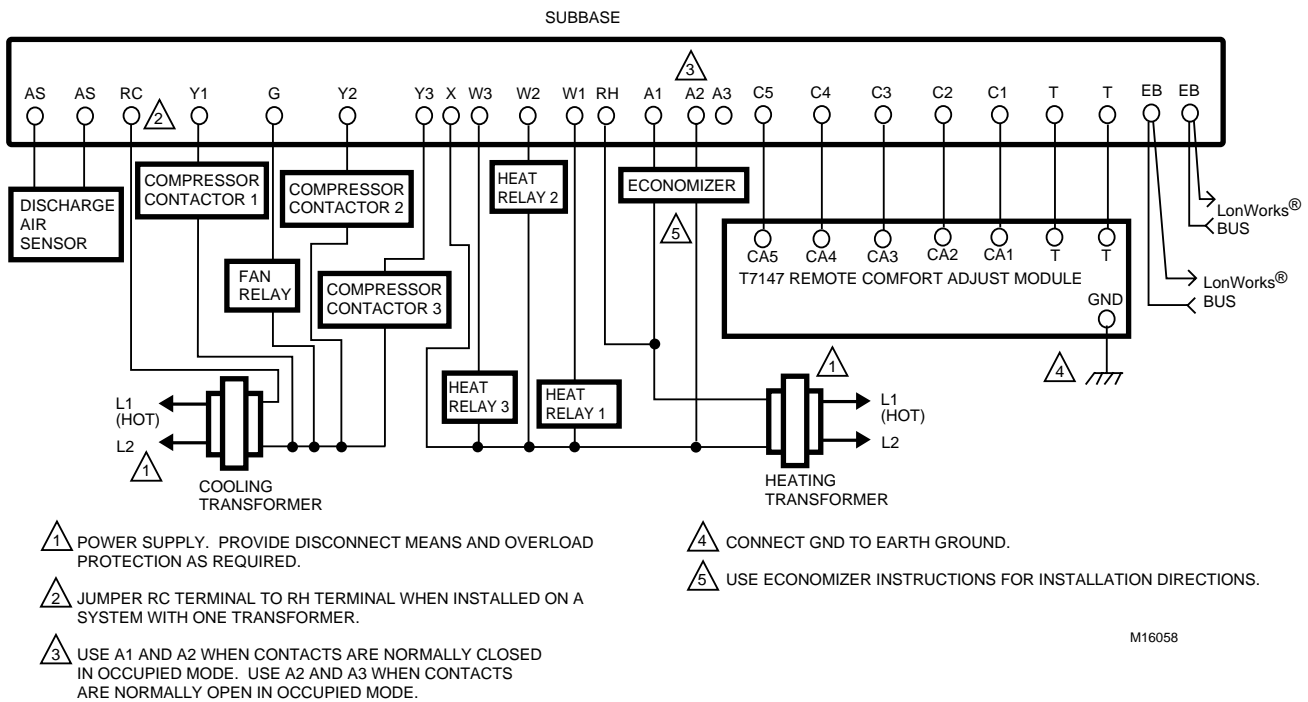

Fig. 28. Typical hookup of T7300F/Q7300H2003 in three-stage heat and two-stage cool heat pump system (without O/B terminals).



**Fig. 29. Typical hookup of T7300F/Q7300H2011 in three-stage heat and two-stage cool heat pump system (with O/B terminals).**



**Fig. 30. Typical hookup of T7300F/Q7300H2029 in three-stage heat and three-stage cool conventional system.**

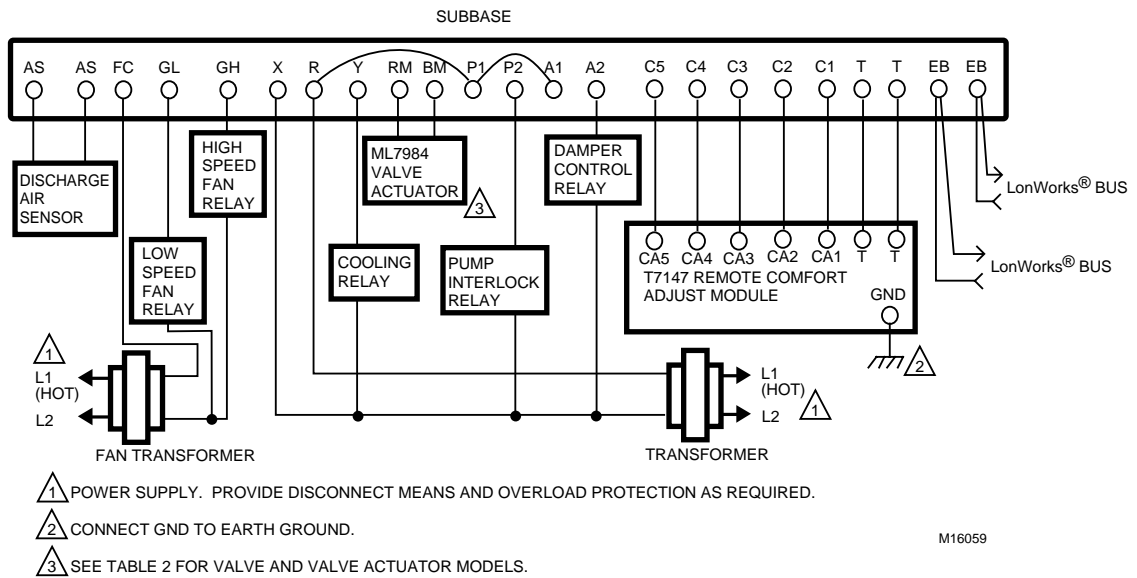

Fig. 31. Typical hookup of T7300F/Q7300H2037 in two-stage heat and one-stage cool conventional system.

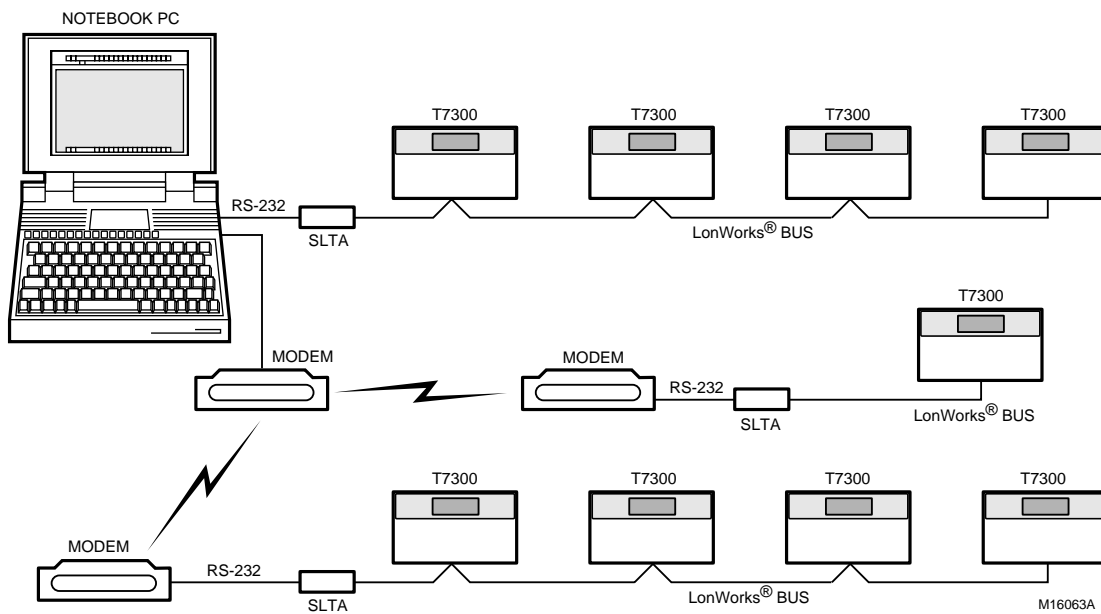
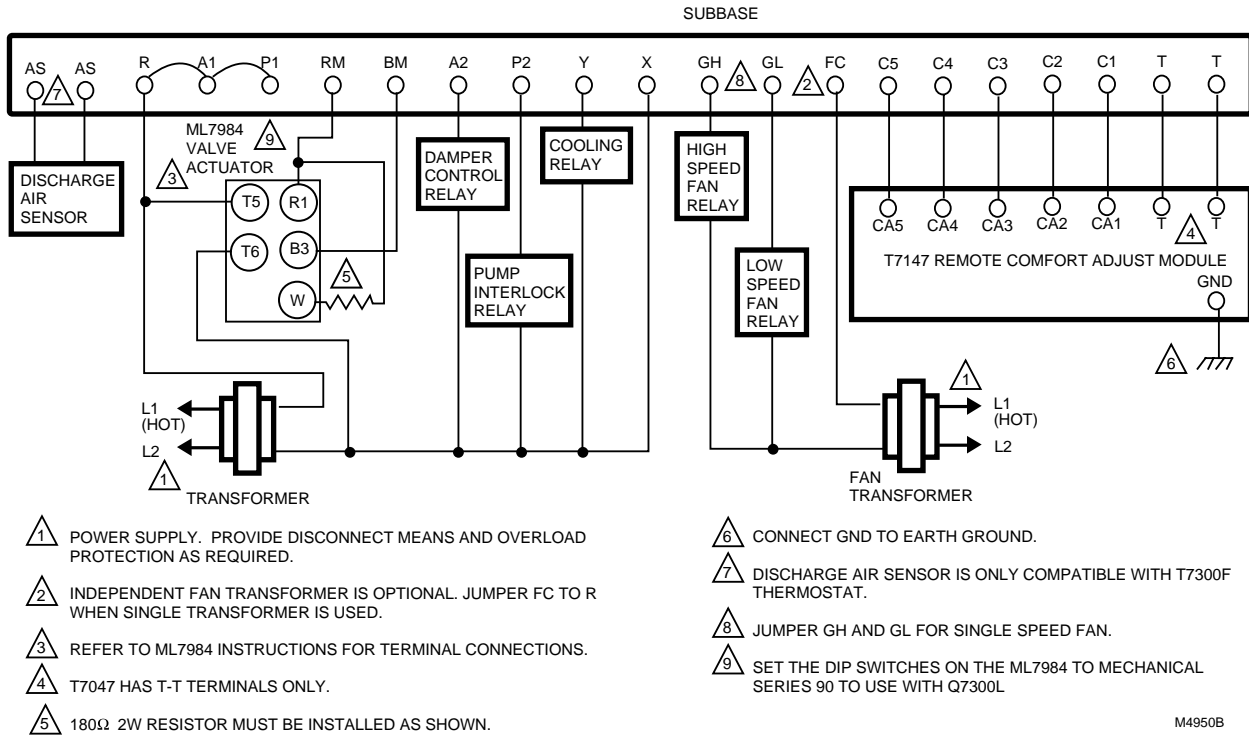

Fig. 32. Typical hookup for T7300F/Q7300H devices in Lonworks® network.



**Fig. 33. T7300D,F/Q7300L2004 for two-stage heating with three-position ML7984 Valve Actuator and V5013B Valve and one-stage cooling.**

**Home and Building Control**

Honeywell Inc.  
Honeywell Plaza  
P.O. Box 524  
Minneapolis MN 55408-0524

**Honeywell Latin American Region**

480 Sawgrass Corporate Parkway  
Suite 200  
Sunrise FL 33325

**Home and Building Control**

Honeywell Limited-Honeywell Limitée  
155 Gordon Baker Road  
North York, Ontario  
M2H 3N7

**Honeywell Europe S.A.**

3 Avenue du Bourget  
1140 Brussels  
Belgium

**Honeywell Asia Pacific Inc.**

Room 3213-3225  
Sun Hung Kai Centre  
No. 30 Harbour Road  
Wanchai  
Hong Kong

**Honeywell**

