

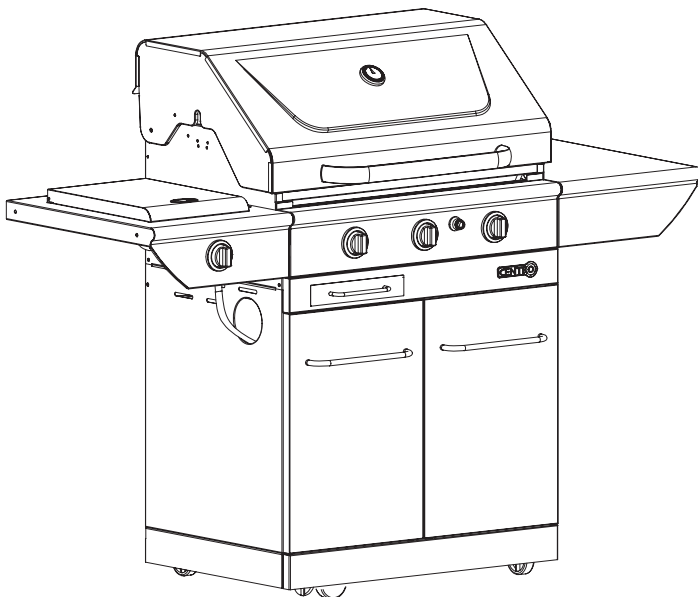

Barbecue Stainless 4000AS

SAFE USE, CARE AND ASSEMBLY MANUAL



FOR YOUR SAFETY

If You Smell Gas

1. Immediately turn off the flow of gas to the unit.
2. Extinguish any open flame.
3. Open the lid of the unit.
4. If the odour does not stop quickly, immediately call your gas supplier or Fire Department for assistance.

FOR YOUR SAFETY

1. Do not store or use gasoline or other flammable vapours and liquids in the vicinity of this or other appliance.
2. An LP Gas cylinder not connected for use shall not be stored in the vicinity of this or other appliance.

WARNING

Failure to follow all of the manufacturer's instructions could result in hazardous fires, explosions, property damage, or serious personal injury or even death.

WARNING

Follow all leak check procedures carefully prior to operation of barbecue, even if barbecue was stored assembled. Do not try to light this barbecue without reading the Lighting Instructions section of this manual.

5 YEAR LIMITED WARRANTY

(G50201) 85-1282-0 (PROPANE)

(G50203) 85-1285-4 (NATURAL GAS)

Read and save this manual for future reference.

If pre-assembled, leave this manual with unit for consumer's future reference.

For product inquiries, parts, and warranty and troubleshooting support, please call

1-877-707-5463

**THIS BARBECUE IS FOR
OUTDOOR USE ONLY**

TABLE OF CONTENTS

Warranty	ii
Installation	1
Additional Warnings	1
L.P. Gas Cylinder,	1
Transportation and Storage of Cylinder, Filling the Cylinder	
Hose and Regulator	3
Leak Testing,	3
Lighting the Grill	5
Tips on Using	7
Your Barbecue	
Cleaning and Maintenance, . . .	8
Storage	
Troubleshooting Guide	9
Parts List and	10
Parts Diagram (Propane)	
Parts List and	12
Parts Diagram (Natural Gas)	
Assembly Instructions	14
Information on Natural Gas . . .	20



WARRANTY

5 Year Limited Warranty

This Centro BBQ carries a five year limited warranty against defects in manufacturing workmanship. This Limited Warranty is nontransferable and becomes void if used for commercial or rental purposes. This warranty applies only when grill is used in Canada. The bill of sale or a copy will be required together with the serial number and model number when making any warranty claims from Trileaf Distribution. Trileaf Distribution reserves the right to have its representatives inspect any product or part prior to honouring any warranty claim. Trileaf Distribution shall not be liable for any transportation charges, shipping and handling charges, or labour cost. This warranty is for replacement of defective parts only. The Manufacturer will not be responsible for incidental or consequential damages or any labor cost. Inability to provide proof of purchase, or if warranty coverage has expired, any request for parts will be subject to parts, shipping and handling fees. This limited warranty does not cover damage due to chipping and scratching of porcelain or painted surfaces including Cooking grates, nor does it cover corrosion or discolouration due to misuse, lack of maintenance, grease fires, hostile environments, accidents, alterations, abuse or neglect, improper installation and failure to read and/or abide by any product warnings. This limited warranty does not cover any damage sustained during removal or storage of this BBQ. Part failure due to lack of cleaning and maintenance, or use of improper cleaning products such as Oven Cleaner, will not be covered under this manufacturers warranty. This limited warranty does not cover any scratches or dents, corrosion or discolouring caused by heat, abrasive or chemical cleaners. Parts installed from other manufactures will nullify this warranty.

5 Year Limited Warranty

Should deterioration of parts occur to the degree of non-performance within the duration of the warranty coverage a replacement part will be provided. The following functional parts are included under this warranty: burners, manifold assembly and carryover assembly.

3 Year Limited Warranty

Should deterioration of parts occur to the degree of non-performance within the duration of the warranty coverage a replacement part will be provided. The following functional parts are included under this warranty: cooking grates, flame tamers and regulator.

1 Year Limited Warranty

For one year from the date of original retail purchase Trileaf Distributions will replace any grill part that fails or is found to be defective to the degree of non-performance under normal household use, during the limited warranty period. Trileaf Distributions Ltd. is not responsible for any grill damage sustained during moving, storage, assembling or cleaning. Unless otherwise noted, as in above limitations, all components are covered for a period of one year.

IMPORTANT: Should you have difficulty operating this product, or have a part that has become defective within the stated warranty period, DO NOT RETURN TO STORE. STORES DO NOT STOCK REPLACEMENT PARTS AND ARE UNABLE TO HELP WITH TROUBLESHOOTING ADVICE. PLEASE CALL 1-877-707-5463. Have your Proof of purchase, serial number and model number available so that the customer support agent can be of assistance.

Purchaser: By accepting delivery of this Barbecue the purchaser, hereby accepts the foregoing and expressly waives any other remedy and damages, direct, indirect, and consequential.

INSTALLATION

The installation of this appliance must be in accordance with all local codes, or in the absence of local codes:

- Canadian installation must conform to the current national standards, which at this time are CAN/CGA-B149.1/2-Natural Gas/Propane installation code.
- For natural gas barbecues, contact a certified gas-technician to install your unit.

ADDITIONAL WARNINGS

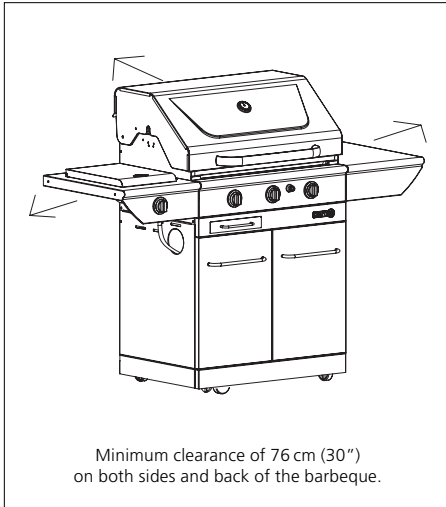

Drawing A

Minimum clearance to adjacent combustible materials:

- 76 cm (30") from furthest protruding edge on side of barbecue.
- 76 cm (30") from furthest protruding edge on back of barbecue.

See Drawing A

- Always keep the area around this barbecue clean and clear of any and all combustible materials such as gasoline or other inflammable liquids, paper or oily rags.
- **Do not** operate this barbecue under any overhanging or unprotected construction.
- Remember this barbecue is for **outdoor use only** and is **not** for use on any boat or recreational vehicle.
- Use this barbecue outdoors in a well-ventilated area and at least 3 m (10') from any dwelling or other building.
- **Do not** use in garages, or any other enclosed area.
- **Do not** leave your barbecue unattended while in operation.
- **Do not** obstruct the flow of combustion and ventilation air to the barbecue.
- **Do not** use while under the influence of drugs or alcohol.
- **Do not** store any spare L.P. (propane) cylinders, full or empty, under or near your barbecue.
- **Do not** allow children or pets to play anywhere near the barbecue.

L.P. GAS CYLINDER

Self-contained Propane Gas System

The self-contained (propane) gas system barbecue is designed to be used with only a 9.1 kg (20 lb) propane cylinder equipped with a type-1 cylinder valve. This barbecue **cannot** be connected to an existing #510 P.O.L. type valve cylinder (which has left-handed threads).

Do not connect to a propane gas cylinder exceeding 9.1 kg capacity or use a cylinder with any other type of cylinder valve connection device.

The Type-1 valve can easily be recognized by the large external thread on the outside of the valve. Older existing valves **do not** have this outer external thread. Any attempt to connect a regulator to any connector other than the mating Type-1 connector (which comes with a large, black coupling nut such as the #510 P.O.L.) could result in fires, injuries or property damage, and could reduce the effectiveness of the important safety features built into the Type-1 system. Also connecting the #510 P.O.L. fitting to the cylinder will negate the flow control and the temperature shut-off features built into the new Type-1 connection system.

- The cylinder should not exceed 472 mm (18 1/2") in height and 317 mm (12 1/2") in diameter.

When purchasing a cylinder for your barbecue, it must be constructed and marked as meeting the specifications of:

- Canada: Transport Canada.

LP-gas supply cylinder to be used must be constructed and marked in accordance with the specifications for LP-gas cylinders of the U.S. Department of Transportation (DOT) or the National Standard of Canada, CAN/CSA-B339, Cylinders Spheres and Tubes for the Transportation of Dangerous Goods.

The Cylinder must also be equipped with:

- A shut-off valve with a correct cylinder valve outlet as specified in current standards.
 - Canada: CAN/CGA 1.6g-M97 Outdoor Gas Grilles.
- a) A safety relief valve with direct connection to the vapour space of the cylinder.
 - b) A collar to protect the tank shut-off valve.
 - c) A device for vapour withdrawal.
 - d) A ring on the bottom to secure the tank to its support assembly.
- Always turn off the cylinder valve completely when the barbecue is not in use.
 - Always handle the tank valve with utmost care.
 - Never connect an unregulated L.P. gas cylinder to the barbecue.
 - Always keep the cylinder, in use, securely fastened in an upright position.
 - Never store a spare cylinder, empty or full, near or under the barbecue when in operation.
 - Never expose the cylinders to direct sunlight or excessive heat.
 - Never insert any kind of object into the valve outlet as this may damage the backcheck; a backcheck that is damaged can leak, and a leaking propane cylinder can result in fires or explosions, property damage, severe injuries or death.

TRANSPORTATION AND STORAGE OF CYLINDER

The propane cylinder is totally safe when handled properly, but if misused, the result could be an explosion or fire resulting in serious personal injury and/or property damage.

To Avoid Unnecessary Risks

- Always recap the cylinder with cap provided when not connected to the barbecue.
- **Do not** store the cylinder in any enclosed area such as a garage, and make sure the storage area has lots of ventilation.
- **Do not** store the cylinder near any appliances, or in any areas that may become hot, such as the trunk of a vehicle.
- Make sure the cylinder is out of reach of children.
- When transporting or storing the cylinder, make sure it is in an upright position and not on its side.
- **Do not** smoke around the cylinder, especially when transporting it in a vehicle.

FILLING THE CYLINDER

The cylinder must be filled prior to use and must have the air purged. For safety, follow these instructions when having your cylinder filled:

- Have only your local qualified LP gas dealer fill or repair a cylinder.
- **Do not** overfill the cylinder beyond the safe 80% fill level.
- Make sure the dealer tests and checks the cylinder for leaks after filling.

WARNING

**If the above instructions are not completely adhered to,
it could cause a fire / explosion, resulting in death or serious injury,
or property damage.**

HOSE AND REGULATOR

Propane Gas Models: Your barbecue is designed to operate on L.P. (Propane) gas at a pressure of 2.74 Kpa (11" water column). A regulator preset to this pressure is supplied with the barbecue and must be used.

This regulator is equipped with the Type-1 quick-closing connecting system, which incorporates these safety features:

- Will not allow gas to flow until a positive seal has been made.
- Has a thermal component that will automatically shut off the flow of gas between 115–150°C (240–300°F).
- Has a flow limiting feature, which will restrict the flow of gas to 10 cubic feet/hour.

Should the large, black thermal-sensitive coupling nut be exposed to any extreme temperatures above 115°C it will soften and allow the regulator probe to disengage from the valve, and will shut off the gas. Should this occur, **do not** try to reconnect the nut; instead replace the whole regulator assembly with a new one (see the attached parts listing for details). The regulator probe also contains a flow-sensitive feature, which limits the flow of gas to 10 cubic feet/hour, in the event of a regulator malfunction or hose leak. If the flow control feature is activated, the cause of this excessive gas flow should be investigated and corrected before using the barbecue again.

Note: Improperly lighting the barbecue can activate the flow control feature, resulting in lower heat output. If this occurs, the re-flow feature must be reset by turning all the burner controls and the cylinder valve off. Wait at least 30 seconds before slowly turning on the cylinder valve, and then after another 5 seconds turn the burner valve on and light the barbecue.

- Never connect this barbecue to an unregulated propane gas supply, or to another kind of gas. **Do not** alter or change the hose or regulator in any way.
- Visually inspect the whole hose assembly before each use for evidence of wear or damage such as cracks, burns, or cuts. If any damage is found, replace the assembly before using the barbecue. Use only the recommended replacement hose.
- To avoid possible damage to the hose, **do not** allow any grease or other hot materials to fall on the hose, and make sure the hose does not contact any hot surfaces of the barbecue.
- The connection fitting must be protected when it's disconnected from the cylinder. **Do not** allow the fitting to bump or drag on the ground as nicks and scratches could help create a leak when connecting back to the cylinder.
- It is important to do the "Leak Test" procedure every time a cylinder is refilled, or any of the components are changed, and especially at the beginning of a new season.
- **Information on connecting Natural Gas Models is located at the end of the manual.**

LEAK TESTING

Perform a "Leak Test"

- Before lighting your barbecue for the first time.
- Every time the cylinder is refilled, or any component is replaced.
- At least once every year, preferably at the start of the season.

The "Leak Test" must be done outdoors, away from heat, open flames and flammable liquids. **Do not** smoke while performing the test. Use only a mixture of 50/50 liquid soap and water for leak testing. Never use a match or open flame.

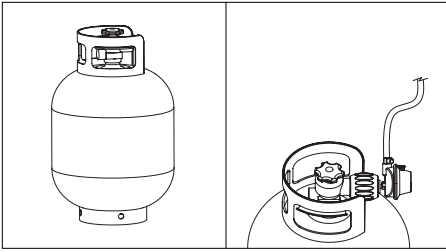

Drawing B

Drawing C

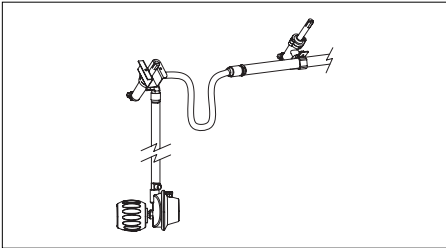

Drawing D

The Following Must be Checked

- The tank valve including the threads into the tank (drawing C).
- All tank welds (drawing B).
- Regulator fittings and tank connections (drawing C).
- All hose connections (drawing D).
- **With a newly filled and tested propane tank attached to the barbecue and all the barbecue controls turned "OFF", slowly open the cylinder valve one full turn.**
- **Using a brush and soap, soak all the connections and components listed above and shown in drawings B, C, D.**
- **Look carefully for bubbles forming, which is an indication of leaking gas.**
- **Tighten the connections at the bubbled areas until re-testing shows no indication of any leaks (shut off cylinder while correcting any leaks).**
- Shut off the cylinder valve and ensure all control valves are off.
- **Do not** use the barbecue if any leaks cannot be stopped. Turn off the gas cylinder valve, remove the gas cylinder and seek assistance from a qualified gas appliance service mechanic or gas dealer.

PRIOR TO USING

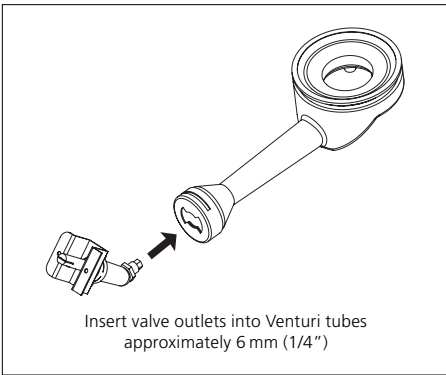

Drawing E

Do not use your barbecue until you have carefully read and fully understand all the information in this manual. Please ensure the following:

- Your barbecue is properly assembled.
- There are no leaks in the system (see "Leak Test").
- The burner is properly assembled, with the Venturi tubes seated over the valve outlets (drawing E) and that there is nothing blocking the Venturi tubes (drawing F).
- Ensure that all power cords and/or gas supply hoses will not touch or be near the surfaces that will get hot.
- The barbecue is in a safe location (see installation).

Ensure that the valve outlets (orifices) are assembled into the Venturi tubes approximately 6 mm (1/4") and that the valve outlets and Venturi tubes are approximately parallel to the bottom of the lower body.

WARNING

Natural Hazards Insects and Spiders

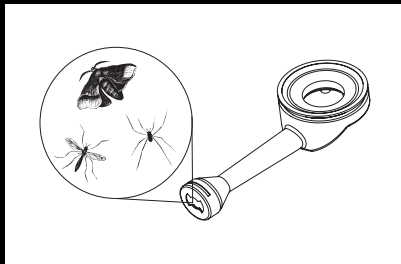

Drawing F

During shipment or storage, it's possible that small insects like spiders could find their way into the Venturi tubes and nest or make webs. This could block the flow of gas through the Venturi tube causing a smoky yellowish flame, or prevent a burner from lighting. It could even cause the gas to burn outside the Venturi tube, which could seriously damage your barbecue. If these occur, turn off the gas flow and wait for the barbecue to cool down. When the barbecue has cooled, remove the burner and clean out the Venturi tubes with a brush or pipe cleaner. Replace the burner and ensure that the Venturi tubes are seated over the orifice located on the gas valves. Cleaning the Venturi tubes should be conducted periodically, especially at the start of the season.

Note: Damage resulting from blocked Venturi tubes is not covered under the warranty.

LIGHTING THE GRILL

- Make sure you have followed all the checks, procedures and instructions indicated in the prior sections before attempting to light the grill.
- Always raise the barbecue lid before lighting the burner.
- **Do not** bend directly over the barbecue while lighting in case of back flash.
- Making sure all the control knobs are off, slowly and carefully open the propane gas cylinder valve. Wait about five seconds before opening the burner valve and lighting the barbecue. This procedure allows the pressure to stabilize, and prevents the flow control feature from activating. **Note:** If the flow control feature does activate, turn off the burner control valve and the cylinder valve, wait about 30 seconds then turn on the cylinder valve slowly. Wait 5 seconds and turn on the burner valve and light the barbecue.

Lighting the Main Burner

- **Important:** Light **centre** burner/burners **first!**
- Once burner is lit the burner next to it will light by turning the control knob to "HIGH".
- **Never** light the outside burners unless the centre burner/burners are lit.

Using the Igniter to Light the Burner

- Raise the lid of the barbecue.
- Turn on tank.
- Push in and turn the control knob to "HIGH" position.
- Push the igniter button until a clicking noise is heard (a spark is being applied).
- If the burner does not light after three attempts, turn the control knob to the "OFF" position and wait for the gas to clear (about 5 minutes). Repeat the previous lighting procedure.
- If the burner still does not light, refer to the troubleshooting guide for help, or light with a long match with extension match holder provided.

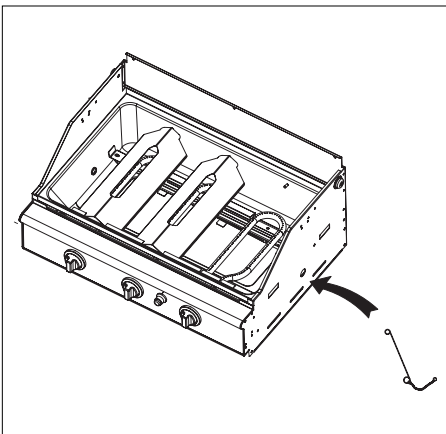

Manual Lighting Procedure

The barbecue has a small hole on the lower left side of the housing. This hole is towards the front of the barbecue and is used to manually light the barbecue.

- Raise the lid of the barbecue.
- Place the lighted match with a match holder, or extension rod provided, through the hole to within 1.6cm (1/2") of the burner.
- Turn on tank.
- Push in and turn the burner knob to the "HIGH" position. At this point, the burner should light, if it doesn't after 5 seconds, turn the control knob back to the "OFF" position and wait for the gas to clear.
- Wait 5 minutes, and then repeat the manual light procedure. If after three tries the burner still does not light, review the troubleshooting guide for help.

To Reset the Gas Regulator Safety Device

- Close the LP (propane) tank valve.
- Turn all burner control knobs to the "OFF" position.
- Disconnect the regulator from the LP tank.
- Open grill lid. **Wait five minutes for gas to clear.**
- Re-connect the regulator to the LP tank. Test for leaks.
- With lid open, turn the centre burner control knob to the "HIGH" position and then ignite the grill by pushing the igniter button.
- Close the grill lid.
- Wait for 10 to 15 minutes. The barbecue should become hot.

WARNING

If the heat output is too low, the flow control feature may have been activated by a gas leak. If so, turn off the burner valve and cylinder valve, and perform the "Leak Test". If there aren't any leaks, re-light the burner.

Lighting the Second Burner

- Turn the second control knob on the main control panel to the "HIGH" position. The unlit burner will automatically ignite.

Lighting the Side Burner

Use the push-button igniter on the main control panel and the right control knob on the side burner panel.

- Push in and turn the right control knob to the "HIGH" position.
- Push the igniter button until a loud click is heard, which is the spark being formed. Repeat several times if the burner does not light.
- If the burner does not light after several tries, turn the right control knob off and wait 5 minutes for the gas to clear.
- Repeat the above instructions. If the side burner still does not light, refer to the troubleshooting section for help or light the burner manually.

Note: The side burner is designed to accept a maximum weight of 20 lb. **Do not** overload the side burner.

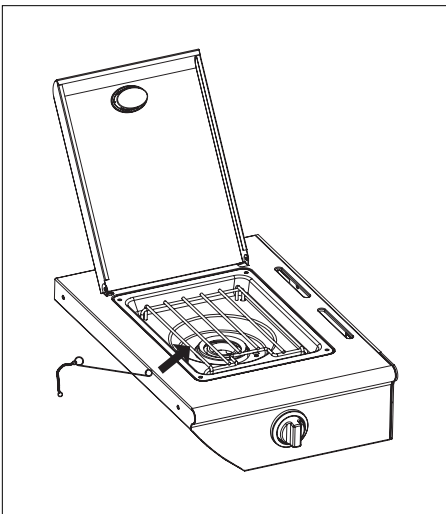

Lighting the Side Burner with a Match

- Place match in front ring of provided match holder.
- Place a lighted match through the hole to within 16 cm (1/2") of the side burner.
- Push in and turn the burner knob to the "HIGH" position. At this point, the burner should light, if it doesn't after 5 seconds, turn the control knob back to the "OFF" position and wait for the gas to clear.
- Wait 5 minutes, and then repeat the manual lighting procedure. If after three tries the burner still does not light, review the troubleshooting guide for help.

Shutting Down the Barbecue After Use

- Turn off the gas cylinder valve.
- Turn the burner control valve to the "OFF" position.

This sequence is important as it prevents residual gas from being left in the system under pressure and will make the next use easier.

Visually Check Burner Flame

Take off the grates and heat shield. Light burners. Adjust the flame by turning the knobs from "HIGH" to "LOW". The flames will be smaller when the knobs are in the "LOW" position. Always check flame prior to each use. Perform flame check for side burner.

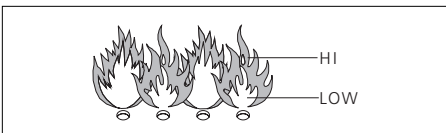

TIPS ON USING YOUR BARBECUE

Using for the First Time: Before cooking, turn on the grill and operate on “HIGH” for about 10–15 minutes with the lid open. Close the lid and continue to run the grill on “HIGH” for another few minutes. After this, your grill should be burned in and ready to use.

Preparation: The barbecue should be preheated before adding any food. This is done by lighting the grill and running at “HIGH” for up to ten minutes with the lid down. If the food you are cooking needs a lower temperature, turn the control knob to the required setting before adding food.

Cooking Time: This is affected by many things and experience in grilling will help you. The kind of food, the thickness of the food, and even the weather can have an effect on cooking time. You will learn that on a hot day, a lower setting will work better and on a cold day a higher setting may work better.

Flare-ups: Flare-ups can increase the temperature in the grill and add to the buildup of grease, increasing the risk of a grease fire. Some flare-ups are normal to create smoke, which helps add to the flavour of your food. To keep these flare-ups to the desired level, do the following:

- Always trim fat from steaks/red meats before grilling.
- Cook chicken and pork on a lower setting.
- Make sure the grease drain hole is clear and that the grease catcher is not filled.
- Always cook with the lid down, and cook at the lowest efficient heat setting.

Note: With the lid down, you will keep a more consistent temperature inside the cooking area and use less energy/gas.

How to Prevent Food From Sticking on the Cooking Grates

- Marinating, or lightly oiling the food before placing it on the cooking grates, will help prevent food from sticking onto the grate.
- Food may stick if turned too soon after putting it on the cooking grates. Let food cook for a few minutes before turning it, so that it will have time to properly sear.

WARNING

Do not leave your barbecue unattended, and watch out for children around the barbecue. Make sure the barbecue is functioning safely at all times. Do not move the barbecue while cooking. Make sure the lava rocks are dry, because when wet they may breakup due to the steam they generate.

CLEANING AND MAINTENANCE

To get many years of service out of your barbecue, perform the following procedures at least once a year, especially at the start of a new season.

Grill: Apply a light coating of cooking oil to the grating to prevent food from sticking. After each use, and after the barbecue has cooled down, scrub the grating with a non-abrasive brush. Alternatively, you can wash the grating with a mild detergent or baking soda, but **do not** use a commercial oven cleaner.

Burner and Venturi Tube: At a minimum of twice a year, it is important to remove the burner and Venturi tube and clean them, making sure that all dirt and rust is removed. Use a wire to clean out the hole in the Venturi tube. Make sure the bottom housing is clean and all holes are clear. If the burner has been damaged or has rusted, replace it as soon as possible. If the burner is in good shape, reinstall it in the correct position. Also ensure that the Venturi tube is centred over the valve outlet.

- Purchase a barbecue cover to protect your investment.
- Stainless steel surfaces should be cleaned with stainless steel appliance spray cleaner, or a non-chlorine based cleaner (e.g. flat-top stove cleaner).
Do not use an abrasive sponge/brush on stainless steel, as it may scratch it.
- **Do not** use oven cleaner anywhere on your barbecue.

STORAGE

When the outdoor cooking season is over and you're going to store the unit for the winter, please do the following:

- After removing and cleaning the burner and grill (lightly oil the grill after cleaning) wrap them in paper and store indoors.
- The barbecue, after being covered, can be stored outdoors.
- **Do not** store the L.P. cylinder in an enclosed area.
- Remove igniter battery to avoid corrosion, if storing unit away in the winter, or a prolonged period.

When the barbecue is not in use, the gas must be turned off at the cylinder valve. The barbecue and cylinder need to be stored outdoors, in well-ventilated area. **Do not** store the barbecue in a garage or near heat. If there is a need for the barbecue to be stored indoors, remove the cylinder. Continue to store the cylinder outside in the well-ventilated area and make sure the cylinder's safety cap is firmly threaded on the valve.

TROUBLESHOOTING GUIDE

Problem	Possible Causes	Corrective Action
Burner will not light (match or igniter)	<ul style="list-style-type: none">• Blocked Venturi tubes	<ul style="list-style-type: none">• Clean out blockage
Burners not hot enough	<ul style="list-style-type: none">• Cylinder or gas supply valve turned off	<ul style="list-style-type: none">• Open cylinder or gas supply valve
	<ul style="list-style-type: none">• Venturi tubes not properly sealed over orifices	<ul style="list-style-type: none">• Ensure proper Venturi assembly
	<ul style="list-style-type: none">• Burner ports blocked	<ul style="list-style-type: none">• Clean/replace burner
	<ul style="list-style-type: none">• Low or out of propane	<ul style="list-style-type: none">• Refill cylinder
	<ul style="list-style-type: none">• Regulator safety device must be re-set	<ul style="list-style-type: none">• Follow How to Reset the Gas Regulator Safety Device (page 5)
	<ul style="list-style-type: none">• Regulator not fully tightened into cylinder	<ul style="list-style-type: none">• Tighten regulator fully (hand tighten) onto cylinder• Straighten fuel hose
Flames smoky yellow	<ul style="list-style-type: none">• Partially blocked Venturi tubes	<ul style="list-style-type: none">• Clean out blockage
	<ul style="list-style-type: none">• Excess cooking salts on burner	<ul style="list-style-type: none">• Clean burner
Burner lights with match but not with igniter	<ul style="list-style-type: none">• Loose wire connection	<ul style="list-style-type: none">• Check all connections are tight
	<ul style="list-style-type: none">• Broken electrode• Poor ground	<ul style="list-style-type: none">• Ensure collector box, burner and igniter are assembled properly
	<ul style="list-style-type: none">• Faulty igniter	<ul style="list-style-type: none">• Replace igniter
Flame blows out/down through base	<ul style="list-style-type: none">• High wind conditions	<ul style="list-style-type: none">• Relocate barbecue back towards wind
	<ul style="list-style-type: none">• Propane low	<ul style="list-style-type: none">• Refill cylinder
Too much heat/excessive flare-up	<ul style="list-style-type: none">• Excessive fat in meat	<ul style="list-style-type: none">• Trim meat, turn down burner controls and/or fuel supply
	<ul style="list-style-type: none">• Grease drain plugged	<ul style="list-style-type: none">• Clean casting base and burner
	<ul style="list-style-type: none">• Cooking system not positioned correctly	<ul style="list-style-type: none">• Position cooking system correctly
Flames under heat control console	<ul style="list-style-type: none">• Blocked Venturi tubes	<ul style="list-style-type: none">• Immediately shut off gas at source, allow grill to cool and clean out Venturi tubes
Regulator humming	<ul style="list-style-type: none">• This is not a defect or a hazard	<ul style="list-style-type: none">• Temporary condition caused by high outside temperatures and a full propane cylinder
Incomplete flame	<ul style="list-style-type: none">• Plugged, rusted or leaking burner	<ul style="list-style-type: none">• Clean/replace burner
Warming rack will not fit	<ul style="list-style-type: none">• Legs are angled too narrowly, or widely	<ul style="list-style-type: none">• The warming rack legs are adjustable. Please bend to fit into the warming rack holes

For more troubleshooting support or parts ordering, please call toll free **1-877-707-5463**.

**PARTS LIST FOR
85-1282-0 (PROPANE)**

Item No.	Quantity	Description	Part No./Spec.
A	1	Top Lid Assembly	
AA	1	Top Lid Weldment	G502-0100-01
AB	1	Handle – Top Lid	G502-0001-01
AC	1	Thermometer	G401-0005-01
BA	1	Warming Rack	G502-0002-01
BB	2	Cooking Grate, Burner Box	G502-0003-01
BC	3	Flame Tamer	G607-0005-01
BD	1	Manifold Assembly	G502-4000-01
BE	2	Main Burner-A	G607-6000-01
BF	1	Main Burner-B	G502-1800-01
C	1	Burner Box Assembly	
CA	1	Burner Box Weldment	G502-0200-01
CB	1	Burner Brace Assembly	G502-0020-01
CC	1	Heat Shield A	G502-0010-01
CD	1	Back Panel, Burner Box	G502-0031-01
DA	1	Upper Side Panel, Left	G502-0300-01
DB	1	Upper Side Panel, Right	G502-0400-01
DC	1	Lower Side Panel, Left	G502-0500-01
DD	1	Lower Side Panel, Right	G502-0600-01
DE	1	Rear Panel	G502-0021-01
DF	1	Bottom Shelf Weldment	G502-0700-01
DG	1	Bottom Rail	G502-0022-01
DH	1	Upper Rail	G502-0023-01
DI	1	Grease Tray Bar-1	G502-0037-01
DJ	1	Grease Tray Bar-2	G502-0038-01
DK	1	Grease Tray	G502-9000-01
DL	1	Warming Tray	G502-9700-01
DM	2	Caster Assembly w/ Lock	G401-0061-01
DN	2	Caster Assembly	G607-0048-01
DO	2	Door Inner Bar	G607-0043-01
DP	1	Door Assembly, Left	G502-7000-01
DQ	1	Door Assembly, Right	G502-8000-01
DR	2	Door Handle	G502-0016-01
DS	1	Match Holder	G608-0019-01
DT	1	Warming Tray Bar-1	G609-0033-01
DU	1	Warming Tray Bar-2	G609-0034-01
EA	1	Control Panel	G502-0008-01
EB	3	Bezel – Control Knob	G401-0022-01
EC	3	Control Knob	G401-0077-01
ED	1	Igniter System	G409-0021-01
F	1	Side Burner Shelf Assembly	
FA	1	Side Burner Shelf Weldment	G607-0800-01
FB	1	Side Burner Drip Pan	G607-0900-01
FC	1	Lid for Sideburner	G607-0026-01
FE	1	Electrode Pole, Sideburner	G401-0037-01
FF	1	Side Burner	G401-0033-01
FG	1	Cooking Grate, Sideburner	G405-0004-01
G	1	Side Shelf Assembly	
GA	1	Side Shelf Weldment	G607-1000-01
GB	1	Towel Bar – Side Shelf	G602-0022-01

85-1282-0 (PROPANE)

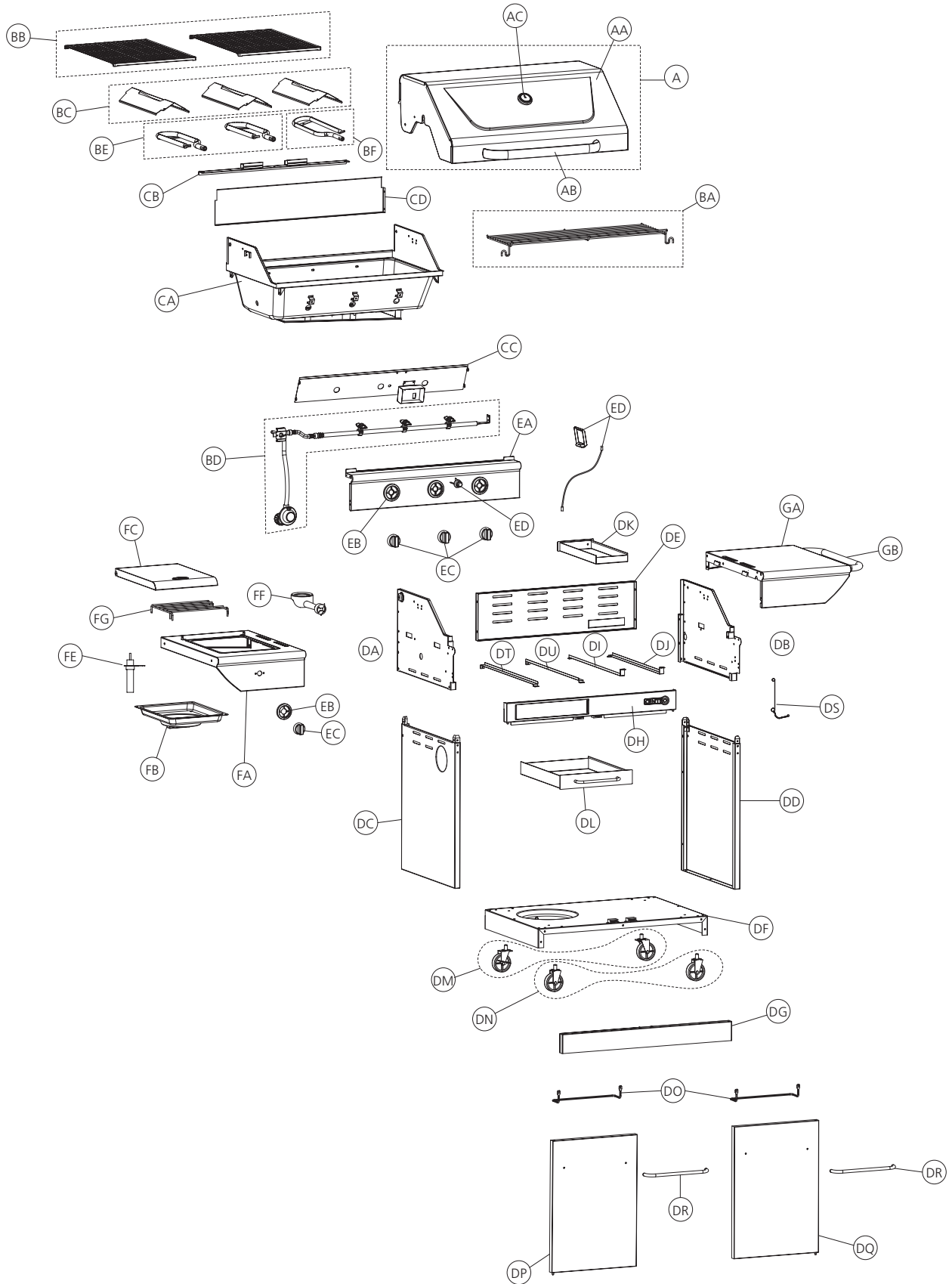

**PARTS LIST FOR
85-1285-4 (NATURAL GAS)**

Item No.	Quantity	Description	Part No./Spec.
A	1	Top Lid Assembly	
AA	1	Top Lid Weldment	G502-0100-01
AB	1	Handle – Top Lid	G502-0001-01
AC	1	Thermometer	G401-0005-01
BA	1	Warming Rack	G502-0002-01
BB	2	Cooking Grate, Burner Box	G502-0003-01
BC	3	Flame Tamer	G607-0005-01
BD	1	Manifold Assembly	G502-4100-01
BE	2	Main Burner-A	G607-6000-01
BF	1	Main Burner-B	G502-1800-01
C	1	Burner Box Assembly	
CA	1	Burner Box Weldment	G502-0200-01
CB	1	Burner Brace Assembly	G502-0020-01
CC	1	Heat Shield A	G502-0010-01
CD	1	Back Panel, Burner Box	G502-0031-01
DA	1	Upper Side Panel, Left	G502-0300-01
DB	1	Upper Side Panel, Right	G502-0400-01
DC	1	Lower Side Panel, Left	G502-0500-01
DD	1	Lower Side Panel, Right	G502-0600-01
DE	1	Rear Panel	G502-0021-01
DF	1	Bottom Shelf	G502-0044-01
DG	1	Bottom Rail	G502-0022-01
DH	1	Upper Rail	G502-0023-01
DI	1	Grease Tray Bar-1	G502-0037-01
DJ	1	Grease Tray Bar-2	G502-0038-01
DK	1	Grease Tray	G502-9000-01
DL	1	Warming Tray	G502-9700-01
DM	2	Caster Assembly w/ Lock	G401-0061-01
DN	2	Caster Assembly	G607-0048-01
DO	2	Door Inner Bar	G607-0043-01
DP	1	Door Assembly, Left	G502-7000-01
DQ	1	Door Assembly, Right	G502-8000-01
DR	2	Door Handle	G502-0016-01
DS	1	Match Holder	G608-0019-01
DT	1	Warming Tray Bar-1	G609-0033-01
DU	1	Warming Tray Bar-2	G609-0034-01
EA	1	Control Panel	G502-0008-01
EB	3	Bezel – Control Knob	G401-0022-01
EC	3	Control Knob	G401-0077-01
ED	1	Igniter System	G409-0021-01
F	1	Side Burner Shelf Assembly	
FA	1	Side Burner Shelf Weldment	G607-0800-01
FB	1	Side Burner Drip Pan	G607-0900-01
FC	1	Lid – Sideburner	G607-0026-01
FE	1	Electrode Pole, Sideburner	G401-0037-01
FF	1	Side Burner	G401-0033-01
FG	1	Cooking Grate, Sideburner	G405-0004-01
G	1	Side Shelf Assembly	
GA	1	Side Shelf Weldment	G607-1000-01
GB	1	Towel Bar – Side Shelf	G602-0022-01
HA	1	Natural Gas Regulator	G409-0024-01

85-1285-4 (NATURAL GAS)

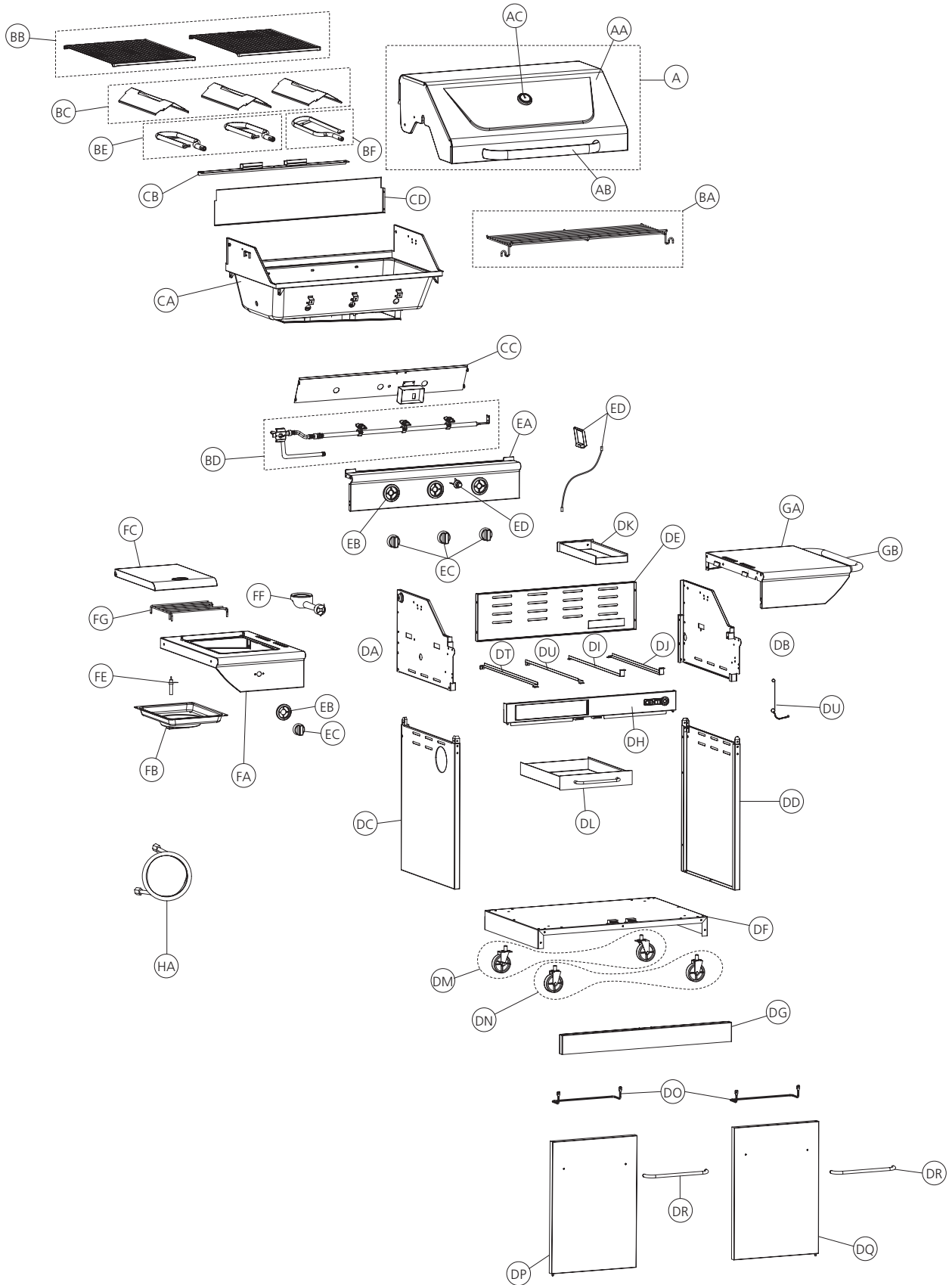

ASSEMBLY INSTRUCTIONS

Tools Needed for Assembly

- #2 Phillips® screwdriver
- 1/4" slotted screwdriver
- Adjustable wrench
- Pliers
- Rubber mallet

Before assembling the barbecue, read these instructions carefully. Assemble the barbecue on a flat, clean surface. Grill is heavy. You should have two people assemble the barbecue together.

Notes: Do not fully tighten all the nuts during this initial stage.

Caution: Sheet metal can cause injury. Wear gloves when installing the grill. Use care when assembling.

Hardware Pack List

No.	Description	Part Number	Quantity
1	1/4" x 35 mm Screw	20120-13035-250	4
2	1/4" x 13 mm Screw	20120-13013-250	12
3	Ø7 Lock Washer	41400-07000-250	16
4	Ø7 Washer	40300-07000-250	16
5	1/4"-20UNC Nut	30220-13000-250	6
6	No.10-24UNC x 10 Screw	20124-10010-250	18
7	Ø5 Lock Washer	41400-05000-250	18
8	Ø5 Washer	40300-05000-250	18
9	No.10-24UNC Nut	30224-10000-250	2
10	ST4.2 x 10 Self-tapping Screw	22500-42010-250	2
11	Knob	G401-0077-9084	1
12	Cover, Knob	G401-0022-0081	1
13	AA Battery	G401-0088-9000	1
14	Wrench	G401-0071-0182	1

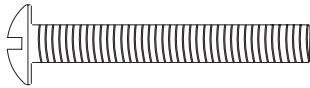

1/4" x 35 mm Screw (x4)



No.10 Nut (x2)

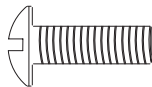

1/4" x 13 mm Screw (x4)

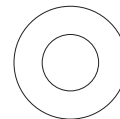

Ø7 Flat Washer (x16)

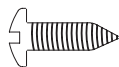

ST4.2 x 10 Self-tapped Screw (x2)

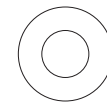

Ø5 Flat Washer (x18)

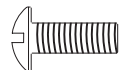

No.10 x 10 Screw (x18)

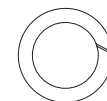

Ø7 Lock Washer (x16)

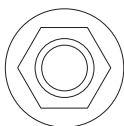

1/4" Nut (x6)



Ø5 Lock Washer (x18)

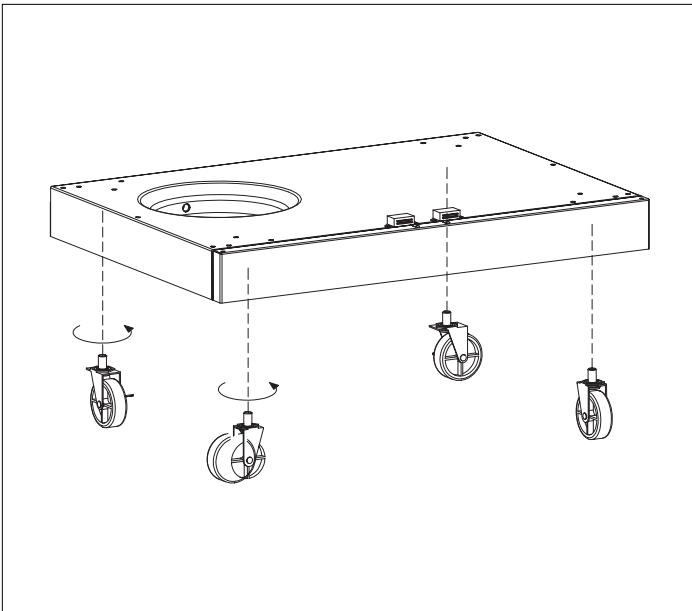

1

Attach two front casters (DN) and two back casters with locks (DM) to the bottom shelf weldment (DF), using the wrench (hardware No. 14).

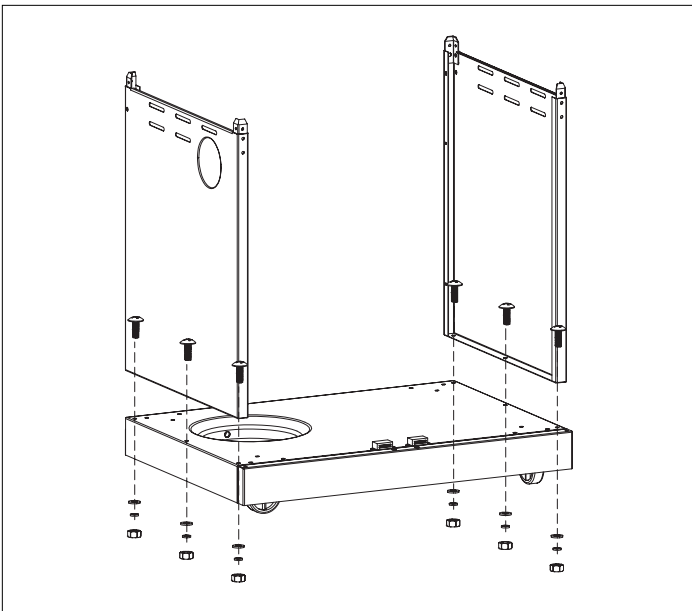

2

Assemble lower left side panel (DC) and lower right side panel (DD) to the bottom shelf weldment (DF), using hardware No. 2, 4, 3, and 5 (x6).

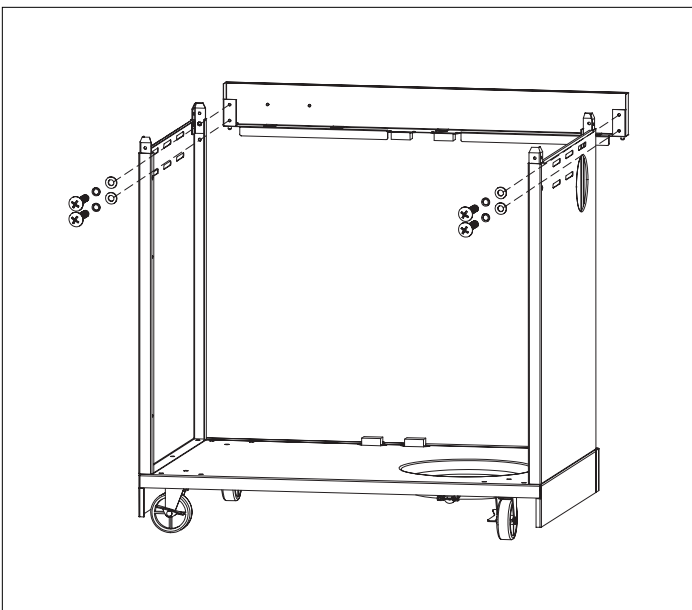

3

Attach the upper rail (DH) to both side panels, using hardware No. 6, 7, and 8 (x4).

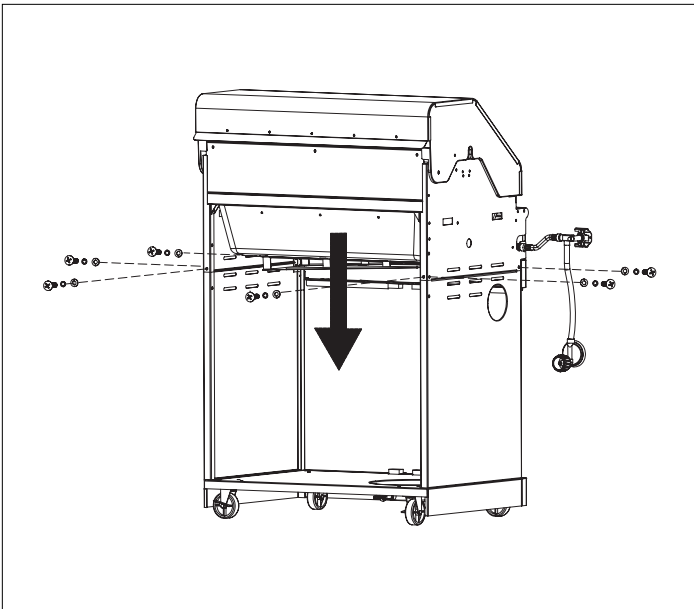

4

Assemble the top lid assembly (A) and burner box assembly (C) to the cart assembly (D). Attach both upper side panels (DA) & (DB) to both lower side panel (DC) & (DD), using hardware No. 6, 7, and 8 (x6).

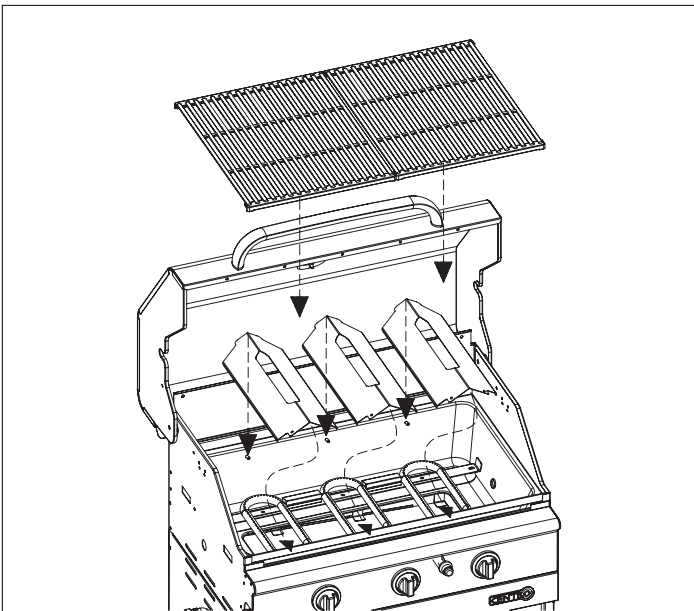

5

Open top lid (A) and position the three flame tamers (BC) as shown. Add the two cooking grates (BB) above the flame tamers.

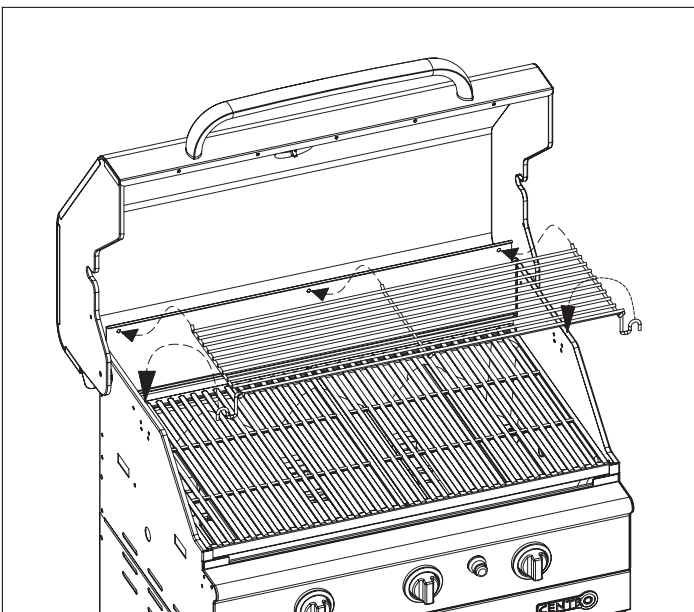

6

Attach the warming rack (BA) to the inside of the top lid (AA) as shown. Make sure the two legs of the warming rack clip onto the edge of the burner box weldment (CA).

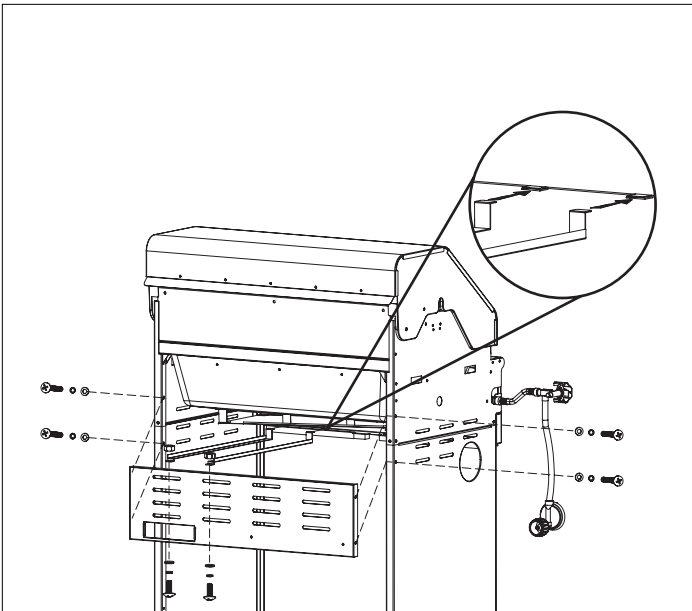

7

1. Insert grease tray bar-1(DI), and grease tray bar-2 (DJ) to the holes on the inside of the cart assembly as shown.
2. Assemble the rear panel (DE) to the back of the burner box using hardware No 1, 3, and 4 (x4).
3. Attach the rear panel to the edge of grease tray bars, using hardware 6, 7, 8, and 9 (x2).

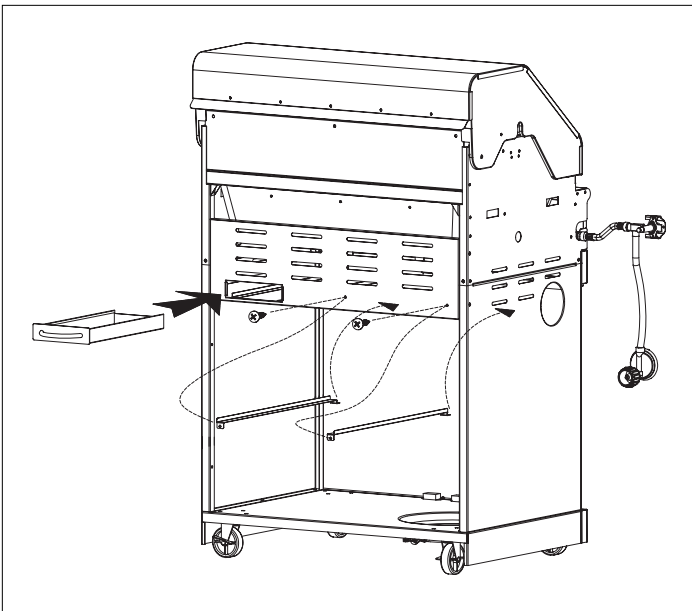

8

1. Assemble the gas tank heat shield to the inside of the rear panel as shown, using hardware No.10.
2. Insert the grease tray (DK) into the rear panel as shown.

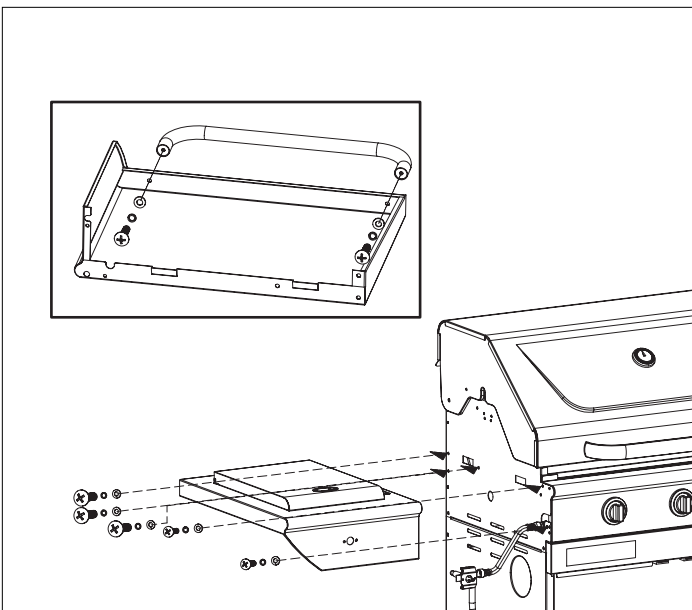

9

1. Remove the two screws, lock washers and flat washers from the towel bar (GB). Assemble the towel bar to the side shelf (GA) by using tools removed previously.
2. Assemble the side burner shelf assembly (F) to the upper left side panel (DA) by using hardware No. 6, 7, and 8 (x2) & No. 2, 4, 3 (x3).
3. Assemble the side shelf assembly (G) to the right side panel (DB).

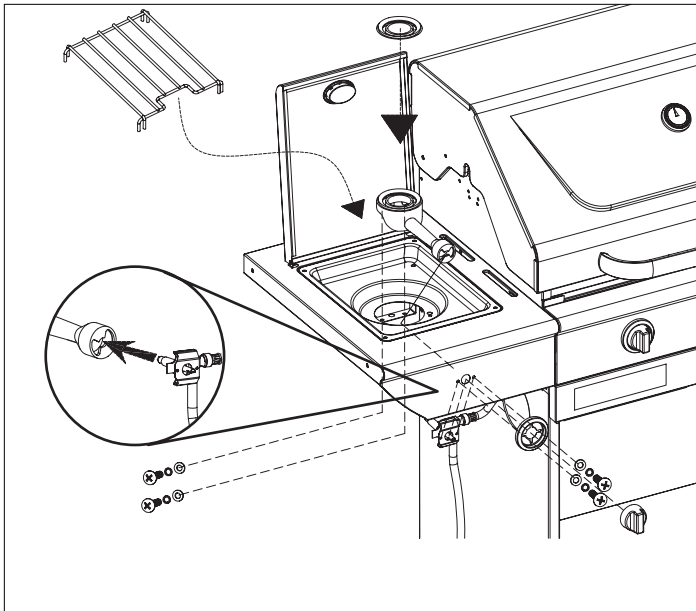

10

Remove the two screws and washers from the side burner valve bracket. Push the side burner valve stem and mount it by using the screws and washers just removed, threading through the side burner control panel and the bezel (EB). Push the knob (EC) onto the valve stem with the white line on the knob pointing upwards. Insert the side burner (FF) into the frame as shown. Gently slide the burner tube over the orifice of the valve. Secure the side burner (FF) to its bracket by using hardware No. 6, 7, 8 (x2). Place the side burner grate (FG) as shown.

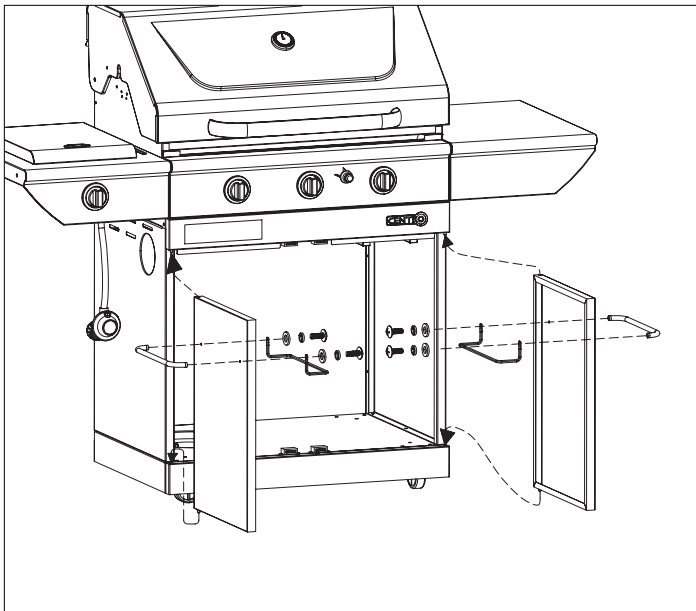

11

1. Remove the screws and nuts from the door handles (DR). Assemble the Door Inner Bar (DO) and Door Handle (DR) to the left Door (DP) and Right Door (DQ) by using those screws and nuts as shown.
2. Mount the left and right doors into position.

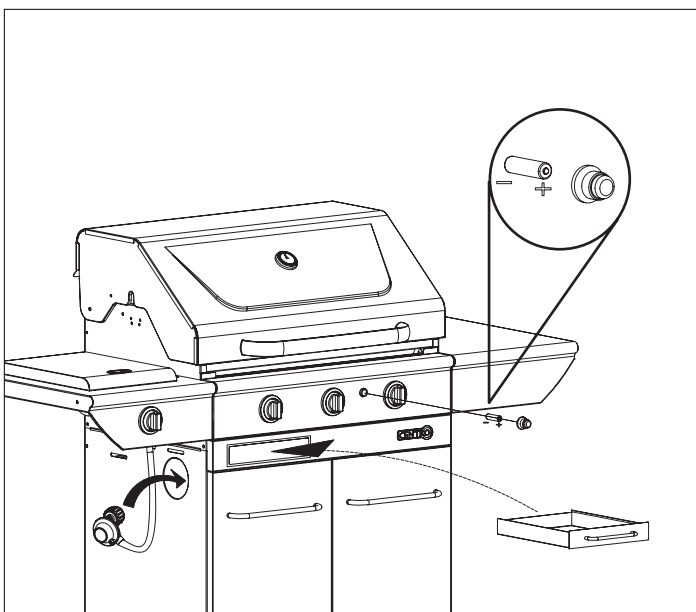

12

Unscrew igniter cap and place AA battery into Igniter (ED) with positive end (+) facing outward. Screw igniter cap onto igniter as shown. Insert the warming tray (DL) as shown.

13

Attach the side burner igniter wire as shown.

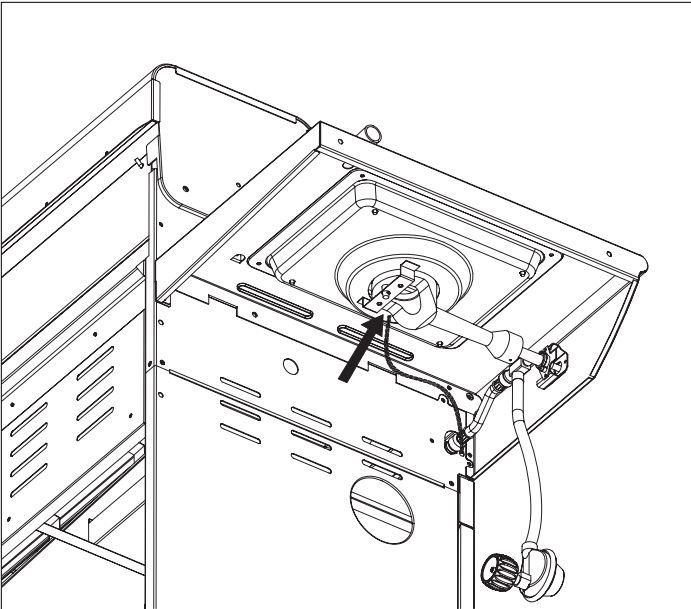

14

For Propane Model ONLY.

Secure 20 lb propane tank onto the bottom shelf of the cart as shown, attach the regulator valve to 20 lb propane tank.

Warning! Do not store the extra tank on the cart.

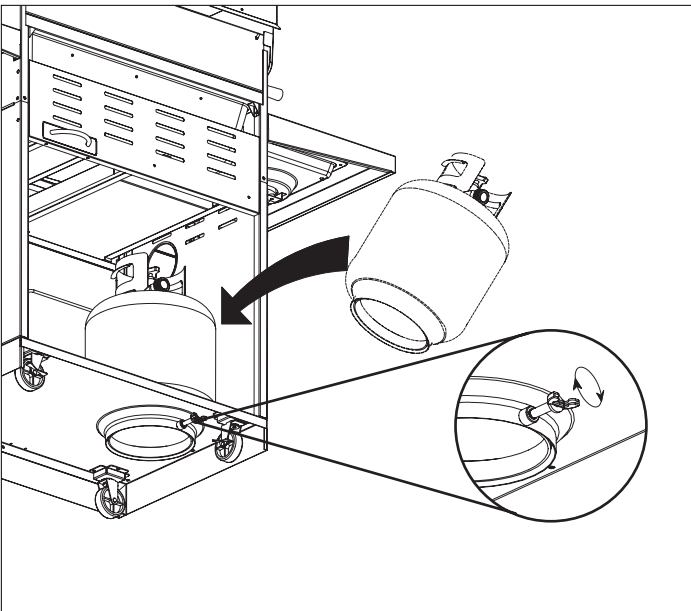

INFORMATION ON NATURAL GAS MODEL

This model has a 12' hose with a male coupling plug that will allow you to attach your barbecue to your residential gas line.

WE STRONGLY RECOMMEND CONTACTING A CERTIFIED GAS-TECHNICIAN TO INSTALL YOUR NATURAL GAS UNIT.

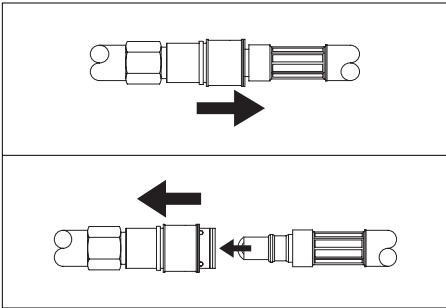

Connecting to Gas Line

1. Pull back the outer sleeve located on the residential gas line (see illustration).
2. Insert the barbecue's male coupling plug into the residential gas line's coupling.
3. Push the male coupling plug in as far as possible, the outer sleeve will spring forward locking the two together (see illustration).

Disconnecting From Gas Line

- Pull back the outer sleeve located on the residential gas line and pull the barbecue's male coupling plug out.

Warning: Failure to follow all safety procedures could result in fire and explosion causing property damage, serious personal injury or even death.

Consult the rating label on the back of the barbecue to confirm that it is set up to burn natural gas. If the retracting sleeve on the residential gas line does not fit the barbecue's male coupling plug, the retracting sleeve can be replaced. All gas supply plumbing must be carried out by a qualified service agency. Modifications must be carried out in accordance with provincial authorities, and in accordance with CAN/CGA 1-B149.1 & 2 installation code requirements. A shut-off valve must be installed on the main line. Use a 3/8 or 1/2" gas line rated at least 75,000 BTUs.

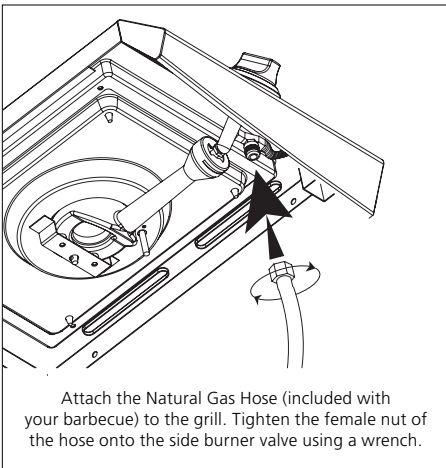

Before lighting for the first time, lighting for the first time each season, and after making any adjustments, do the following:

- Make sure all burner control knobs are in the "OFF" position.
- Always connect the barbecue's gas line to the residential gas line before opening the shut-off valve.
- Perform a "Leak Test". This test must be performed outdoors, away from heat, open flames and flammable liquids. **Do not** smoke while doing the test. Use only a mixture of liquid soap and water. Use a spray bottle or brush to apply the soapy solution to all the connection points. Check carefully for bubbles forming, which is a sign of leaking gas. If you have a leaky connection, turn the gas off, tighten the connections, turn the gas back on and retest. **Do not** use the barbecue if any leaks cannot be stopped. If you can't stop a leak, turn the gas off and get assistance from a qualified service technician. Never use a match or open flame.

Natural Gas Supply Connection

Always disconnect the Grill and close its individual manual shutoff valve, when conducting pressure tests of the gas supply piping system at pressures which exceed 1/2 psi (3.5kPa).

- Always isolate the Grill from the gas supply piping system by closing its individual manual shutoff valve when conducting pressure tests of the gas supply piping system at pressures which are equal to or less than 1/2 psi (3.5kPa).

DISTRIBUTOR

Trileaf Distribution Trifeuil
Toronto, Canada
M4S 2B8

CENTRO 