

# The Shark

## SLICKLINE MEASUREMENT DEVICE WITH COMBINED DEPTH/TENSION

AMSLA101: 2mv/v Load Pin  
AMSLA102: 0 – 1.5vdc Load Pin  
AMSLA103: 4-20ma Load Pin

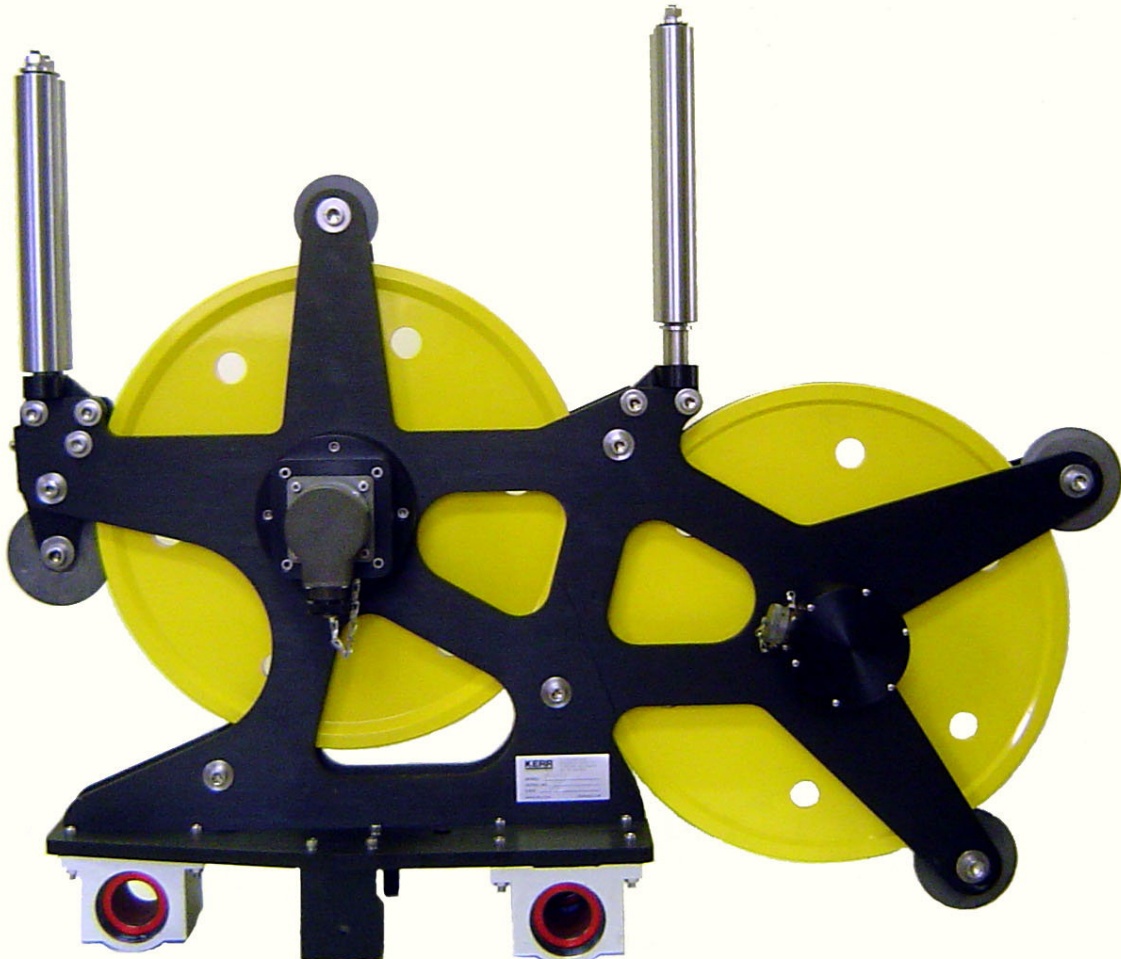

## CONTENTS

1.0	GENERAL
2.0	TECHNICAL DESCRIPTION AND SPECIFICATIONS
3.0	OPERATION
4.0	MAINTENANCE AND REPAIR
5.0	RECOMMENDED SPARE PARTS
6.0	DRAWINGS AND PARTS LISTS

## 1.0 GENERAL

The "SHARK" Slickline Measuring Device is a heavy duty two wheeled device which accurately measures both wireline depth and tension. It minimizes wire abrasion and fatigue by using a non reverse bend configuration.

The device is designed to be mounted in front of the wireline drum on a spooling mechanism. Linear bearings in the mount allow it to slide back and forth in front of the drum so the wire can be spooled evenly. The head can be hung from an overhead bar or can sit on bars located at the base of the drum. Spooling rollers and pressure wheels are provided to keep the wire in the wheels at low or no tension. An optional "turn table" is available which allows the head to be pivoted 90 degrees for shipping protection.



Tension is measured from a load pin which also serves as the axle for the tension wheel. Since the two wheels are opposite each other, the wire completely wraps around both wheels. This creates a relatively high signal at the load pin which provides a very accurate tension measurement.

With the BenchMark Wireline Products Winchman's Panel, depth can be accurately measured on different sized lines without changing wheels. This is done electronically by the panel using the depth information provided by an encoder. Changes in wire size are accounted for by the panel software. Wire stretch can also be automatically calculated by the panel. An adapter is provided to drive a standard mechanical counter.

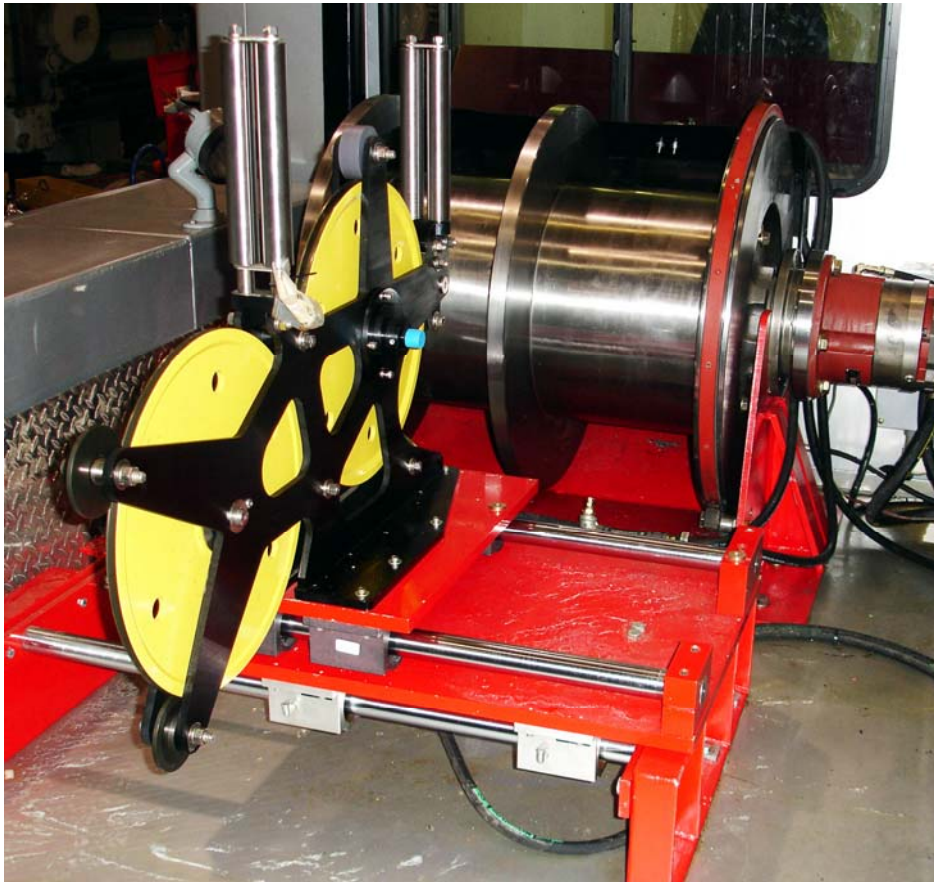

## **2.0 TECHNICAL DESCRIPTION AND SPECIFICATIONS**

### **2.1 WIRE PATH:**

The wire runs from the well around the measure wheel (wheel nearest drum) then around the tension wheel and back across the top of the measuring wheel onto the drum. Even though the wire runs side by side across the top of the measure wheel, the system is designed to prevent wire to wire rub. The tension wheel is tilted slightly with respect to the measuring wheel so that the wire enters the wheel on one side of the groove and exits the wheel on the opposite side of the groove. Guide rollers are aligned to assist in keeping the wire on the proper side of the groove.

The wire runs through a non reversed bend configuration (i.e. the wire is always bent in the same direction). This minimizes wire fatigue due to bending the wire in opposite directions each time it passes through the measuring head. The large wheel radius minimizes the effects of fatigue and promotes longer wire life, especially with larger diameter wirelines.

Guide rollers are installed on the tension wheel to keep the wire in the groove. A spring mounted guide roller is used on the measure wheel to ensure the wire is always pressed tightly against the measure wheel to prevent wire slippage at low tension to minimize measurement error. The spring tightly presses the wire against the wheel regardless of wire size. The spring force keeps the wire turning the wheel even with sudden changes of direction during jarring action. A composite guide roller is mounted above the measure wheel to keep the wire in the groove when wireline tension is relaxed such as during transport and rigup.

### **2.2 DEPTH MEASUREMENT:**

Depth measurement is made by wrapping the wire around the measuring wheel which has a precision machined groove. The wheel groove has a circumference of 4 feet with .125 wire installed. The wheel is hardened to greater than Rockwell 58 by using a special heat treat process. This minimizes wheel wear to maximize wheel life.

This measuring head is capable of providing three completely independent depth measurements, a mechanical counter, an optical encoder, and a magnetic pickup.

The optical encoder provides a high resolution measurement to the BenchMark hoistman's panel. With this panel depth and line speed can be accurately measured on different sized lines without changing wheels. This is done electronically by the panel. Changes in wire size are accounted for by the panel software. Wire stretch can also be automatically calculated by the panel. The

panel operates on 12v and supplies the necessary power to the encoder and load pin.

A backup depth system is available to provide another independent depth measurement. Depth is measured by a frictionless magnetic pickup mounted in the measuring head. The pickup consists of magnets imbedded in the measure wheel coupling and two hall affect devices mounted next to the shaft. This provides a quadrature type measurement. A small display panel is mounted inside a wireline unit. The panel is designed to be connected to an external AC or DC supply or operate off internal batteries for up to 15 hours between charges. In the event of an external power interruption, the unit automatically switches to battery power. The system is designed to operate without intervention from the user. When external power fails, the depth display is maintained by the batteries. A switch on the front of the panel allows different sizes of wire to be measured accurately without changing the measuring wheels.

The mechanical measurement is made by connecting a “speedometer” cable to the hub of the measuring wheel. A “Veedor Root” type counter can be used. Step down adapters are available to convert from a 4:1 to a 1:1 measurement (adapters on the wheel and in the counter). The mechanical system cannot be adjusted for different wire sizes so a wheel with a different sized groove must be installed to make the mechanical measurement correct.



## 2.3 TENSION SPECIFICATIONS:

The wheel nearest the well rotates on an axle pin that is instrumented with strain gauges. These strain gauges produce an electrical signal proportional to the magnitude of line tension. The wire always makes a complete 180 degree wrap around the tension wheel so rigup angle does not affect the tension measurement.

The tension wheel is mounted on a self aligning bearing which allows the wheel to properly align itself. This reduces any side forces that may be present which increases the tension measurement accuracy.

There are three tension interfaces available:

### PASSIVE BRIDGE:

Power Requirements: 12 excitation voltage

Interface: None – passive bridge only

### DIFFERENTIAL VOLTAGE:

Power Requirements: +/- 15 vdc input power

Interface: Proprietary circuit board which amplifies the load pin signals and provides a 1.5v differential output.

0 vdc = 0 lbs (0 kg)  
 1.2 vdc = 4000 lbs (1814 kg) - shunt cal  
 1.5 vdc = 5000 lbs (2268 kg)

#### 4-20MA CURRENT LOOP

Power Requirements: +24vdc input power

Interface: Proprietary circuit board which amplifies the load pin signals and provides a 4-20ma current loop output.

4 ma = 0 lbs (0 kg)  
 16.8 ma = 4000 lbs (1814 kg) - shunt cal  
 20ma = 5000 lbs (2268 kg)

#### TEMPERATURE STABILITY

<= .015% full scale / deg F on zero  
 <= .02% full scale / deg F on output

ACCURACY 1% full scale nominal

MAXIMUM LOAD (tested): 4500 lbs (2040 kg)  
 (calculated): 5000 lbs (2268 kg)

#### 2.4 GENERAL SPECIFICATIONS:

Height: 29.5" .75 m

Length 37" .94 m

Width: 11.5" .292 m

Weight: 94 lbs 42.6 kg

Maximum Tension: 4500 lbs 2040 kg

Line Sizes: .092" – 3/16" 2.3 mm – 4.76 mm

Encoder: 1200 PPR (or customer specification)

Backup Counter: 4 PPR Quadrature

Load Pin: 4-20 ma, Differential voltage, Passive Bridge

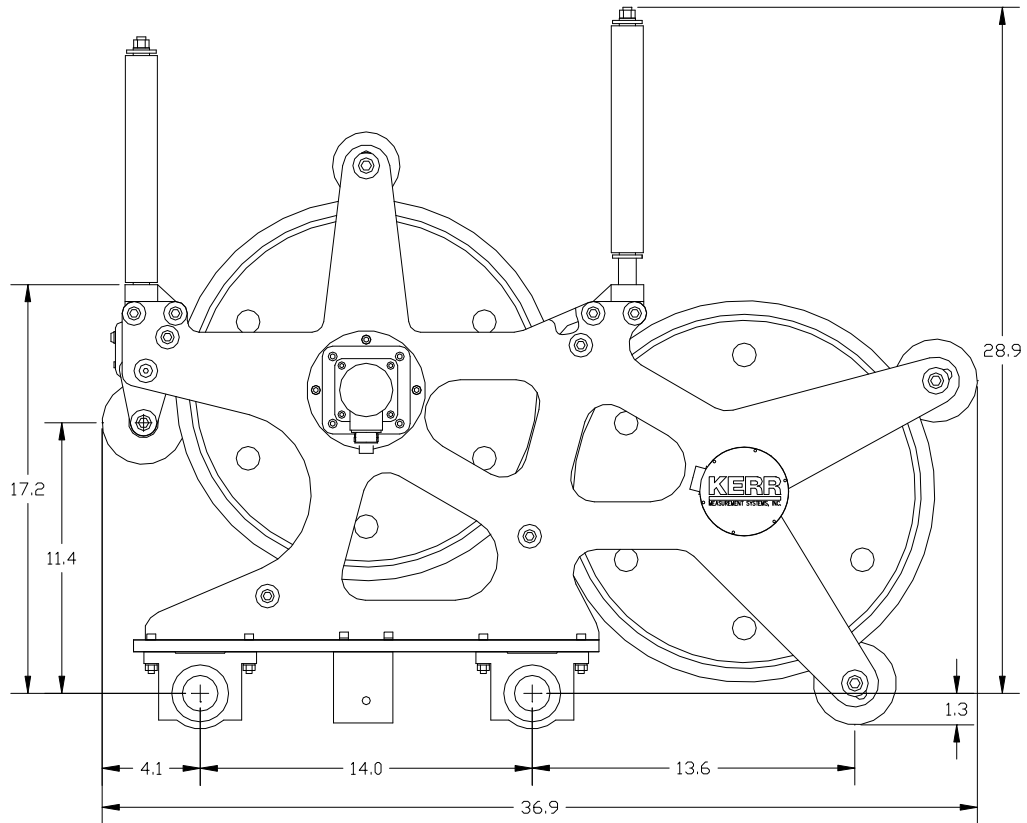



### 3.0 SYSTEM OPERATION

#### 3.1 Determine wireline size to be used – .092" to 3/16"

Since the wireline wraps around the depth wheel, the circumference of the depth wheel will change with a change in wire size. The wheel size needs to be corrected for wireline size in order to accurately measure depth.

These corrections are automatically made in the BenchMark hoistman's panel by selecting the proper cable size using the menu. If a different panel is used, the wheel size will need to be set at this time.

#### 3.2 Install wire in measuring head using the following procedure: (refer to figure on following page).

1. Run the wireline from the drum, through the drum side spooling rollers, onto the left side (facing the drum) of the depth wheel.
2. Pull the wireline across the depth wheel, under the spooling roller plate around the tension wheel.
3. Make sure the guide rollers are loose so the wireline can be installed on the tension wheel.
4. Pull the wireline from the bottom of the tension wheel around the bottom of depth wheel, under the spring mounted tension roller (mounted on the rear of the depth wheel), around the top of the depth wheel (right side), and through the rig side spooling rollers.
5. To open the spring mounted pressure roller, press on the back near the spring or insert a hex wrench into the pressure roller bolt and pull back.
6. After the wireline is installed, tighten the guide rollers. They should be barely touching the wireline in the tension wheel. If they are pressed too tightly against the wireline, the tension measurement will be affected.

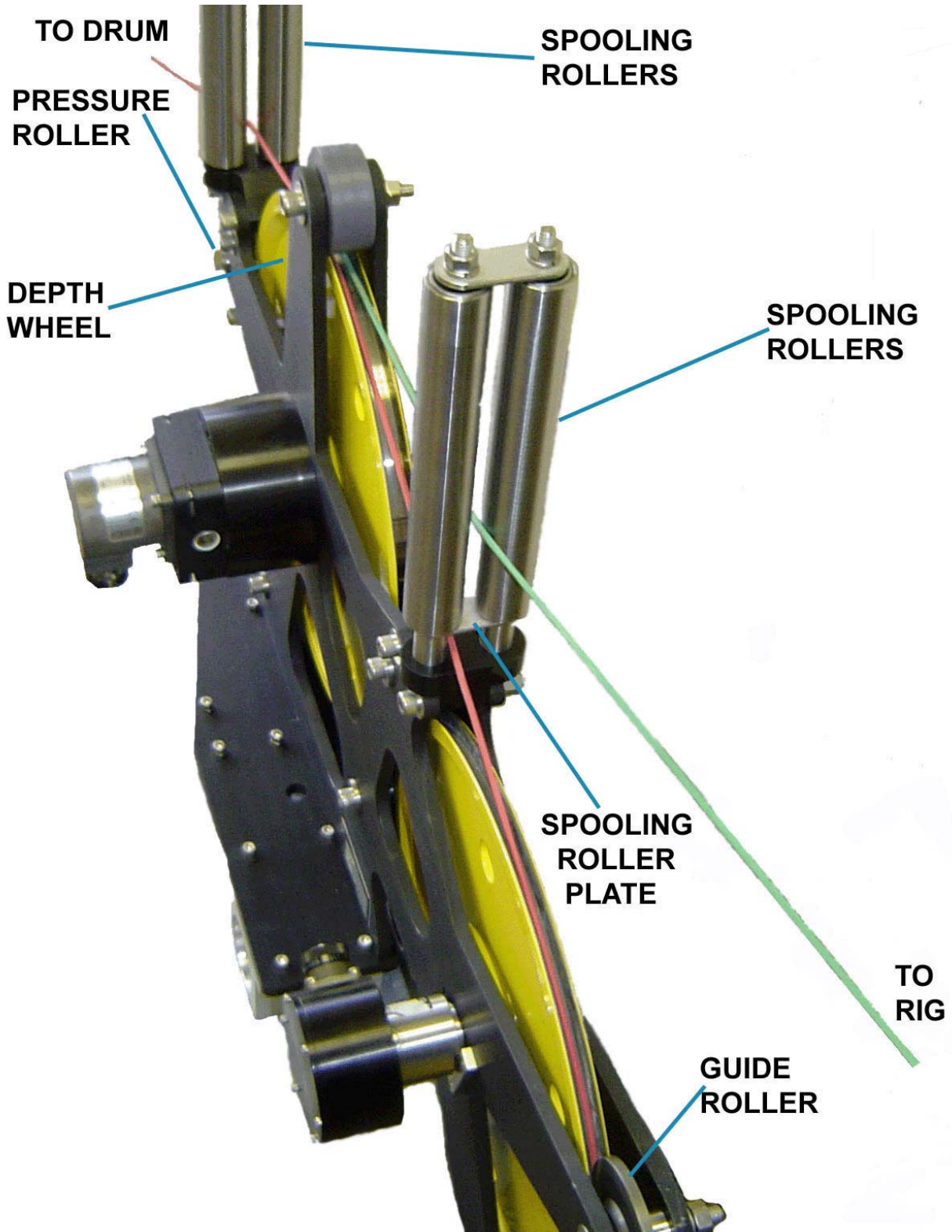

- 3.3 Make sure line is laying slack and head is free to move. Press the T Zero button and tension value should read 0.
- 3.4 Press the T Cal button and verify that the tension reads close to 4000 lbs. (1815 kg).
- 3.5 Press the Zero Depth button to set the depth to zero when the tool is hanging at the zero point.
- 3.6 Simultaneously press the enable and zero button on the backup display panel at this time to zero it.
- 3.7 At this point, the system is ready to log.
- 3.8 Operators must remain alert for visual indications of mechanical failures such as excessive vibration, wheel and roller slippage or lockups that signify bearing or shaft failures. If damaged or worn parts are detected or suspected, the unit should be immediately repaired.

## **4.0 MAINTENANCE AND REPAIR**

### **4.1 PRE AND POST JOB CHECKS**

Between jobs, check the measuring and guide wheels for looseness, play, out-of-roundness, worn or rough sounding bearings, or other mechanical conditions that could affect measurement accuracy.

Visually inspect the interiors of the electrical connectors for the encoders and electronic load axle for dirt and evidence of insulation breakdown. Clean or replace as necessary. Install dust caps on the connectors if the cables are removed.

Manually rotate each wheel by hand to verify its condition. Inspect the depth measuring wheel for signs of abnormal wear diameter changes, or shaft play that can affect measurement accuracy. The wheel should be replaced if it is grooved more than .005".

Inspect the tension wheels for signs of abnormal wear, diameter changes, or shaft and bearing play that could affect measurement accuracy. It should also be replaced if it is grooved more than .005".

**Do not pressure wash**

## 4.2 MONTHLY MAINTENANCE

Grease the wheels and bearings that are fitted with a grease fitting. Use a marine grade grease. An inverted grease nozzle is supplied with each head. This nozzle (BenchMark p/n AM5KP130) will fit any standard grease gun.

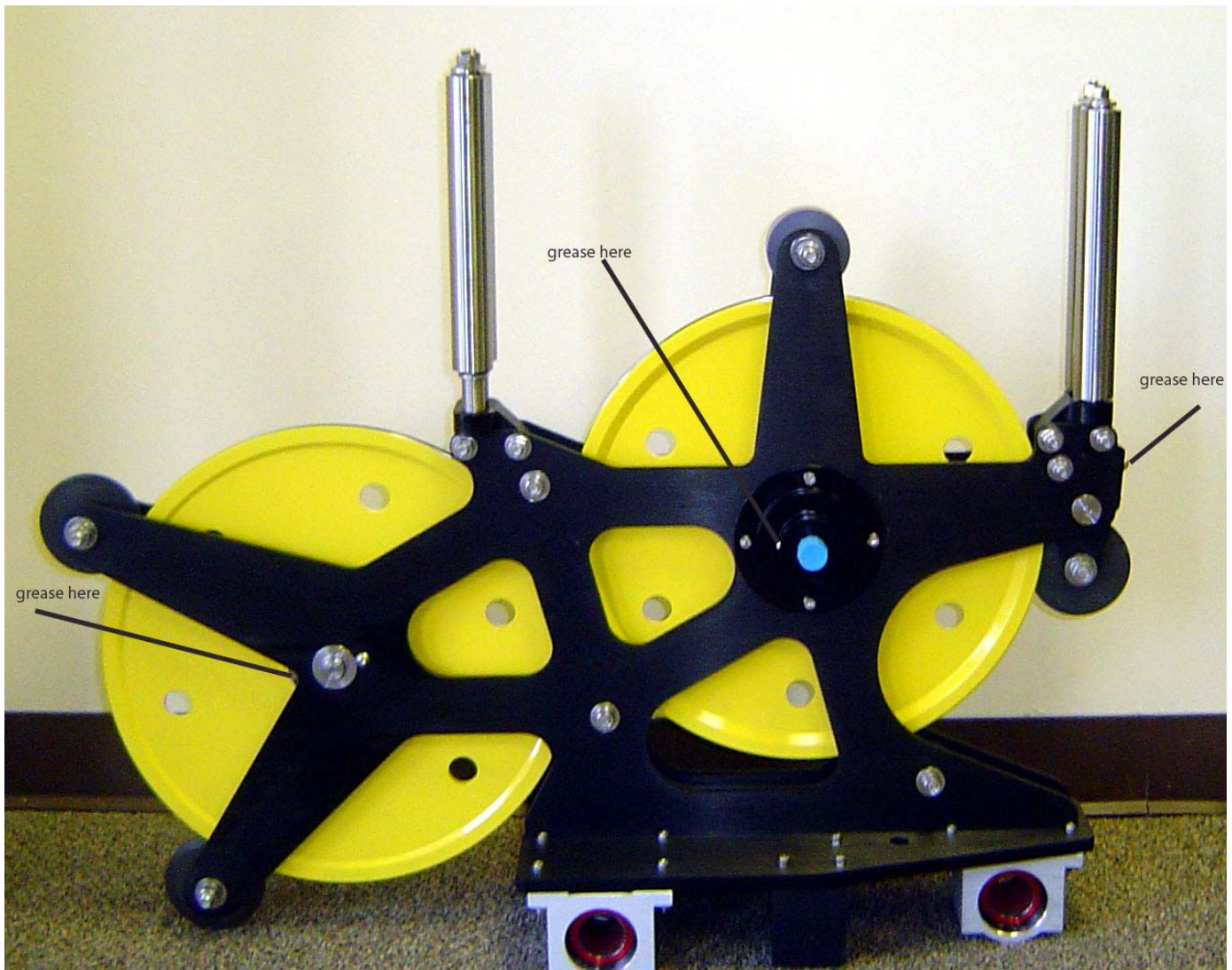

## **4.3 ASSEMBLY / DISASSEMBLY PROCEDURES**

### **4.3.1 ELECTRONIC LOAD PIN REMOVAL**

The electronic load pin is held in place by one retaining ring on the outer end of its shaft. Remove the retaining ring. The load pin can then be removed from the mounting frame.

### **4.3.2 BACKUP DEPTH MAGNETIC PICKUP REMOVAL AND INSTALLATION**

The backup depth magnetic pickup is mounted to the encoder adapter. It is held in place by four screws. Remove the screws and the pickup can then be removed. The pickup must be properly oriented to work correctly. The slot should be oriented to the top. The top side is the encoder side. Ensure that an o-ring is inserted between the plastic housing and the mount. An additional o-ring is used between the connector and the housing to keep moisture out.

If the backup display is counting backward (i.e. counting negative when going downhole), simply rotate the pickup 180 degrees to change the direction.

### **4.3.3 ENCODER COUPLING INSTALLATION**

To install the encoder coupling, first remove the plug in the encoder adapter.

Next, install the encoder on the outer encoder adapter.

Using a hex head wrench, tighten the set screws on the coupling then replace the plug.

## 5.0 RECOMMENDED SPARE PARTS

Following is a list of recommend spare parts. Parts designated REMOTE are recommended only for areas that have a very difficult time getting parts shipped to. For all other areas, it should not be necessary to stock the REMOTE parts locally.



ITEM	P/N	DECSRIPTION	QTY	UM	REF
10	AMSLM057	WHEEL MEASURING 4FT UNIV 2 WHL 0.092 -3/16	1	EA	REMOTE
11	AMSLM012	WHEEL TENSION 4 FT 2 WHL CNTR	1	EA	REMOTE
12	AMSLA033	WHEEL ASSY PRESS ROLLER TENSN W/BEARING	1	EA	
13	AMSLA034	WHEEL ASSY PRESS ROLLER MEASR W/BEARING	1	EA	
14	AMSLM019	ROLLER GUIDE VERT LEVELWIND	1	EA	
20	AMSLA010	ASSY LOAD AXLE 0-1.5V 3/4 DIA	OPT	EA	REMOTE
20	AMSLP063	ASSY LOAD AXLE 2MV/V 3/4 DIA	OPT	EA	REMOTE
20	AMSLA015	ASSY LOAD AXLE 4-20MA 3/4 DIA	OPT	EA	REMOTE
33	AMSLM033	ROLLER KEEPER UNIVERSAL	1	EA	
49	AM5KA055	ASSY ENCODER BACKUP MAGNETIC	1	EA	REMOTE
50	AMSLP061	ENCODER HD2.5D-0-SS-37F-1200-	1	EA	
51	C276M055	COUPLING ENCODER H25 TO RELIANCE ADTPR	1	EA	
52	AMSLP039	BEARING SPHERE-ROL 30MM ID W/SEALS	1	EA	
53	C276P001	BEARING BALL 25MM MRC5305- MZZ (CZZ)	1	EA	
54	AM3KP021	BEARING BALL 10MM FAFNIR 200PP	4	EA	
99	AM5KP130	NOZZLE GREASE FITTNG FLUSH	1	EA	



## 6.0 DRAWINGS AND PARTS LISTS

### 6.1 MEASURE HEAD ASSEMBLY

#### SIDE VIEW

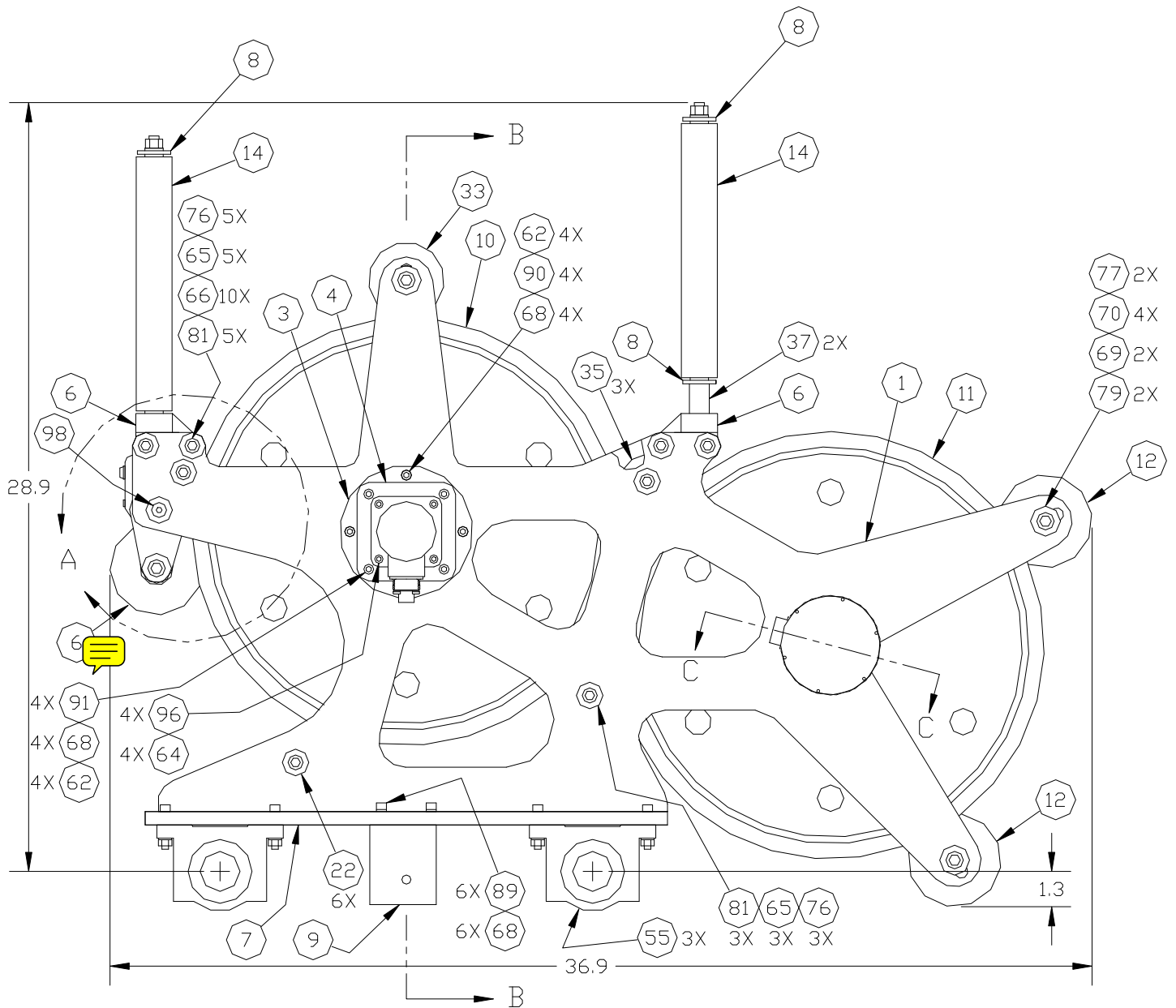



## FRONT VIEW

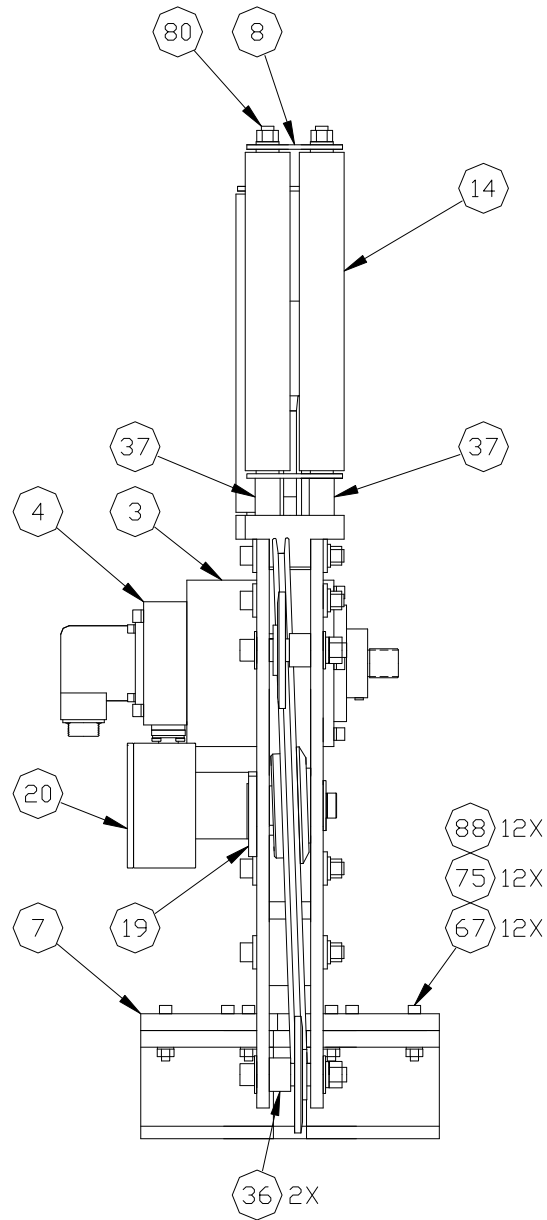

## REAR VIEW

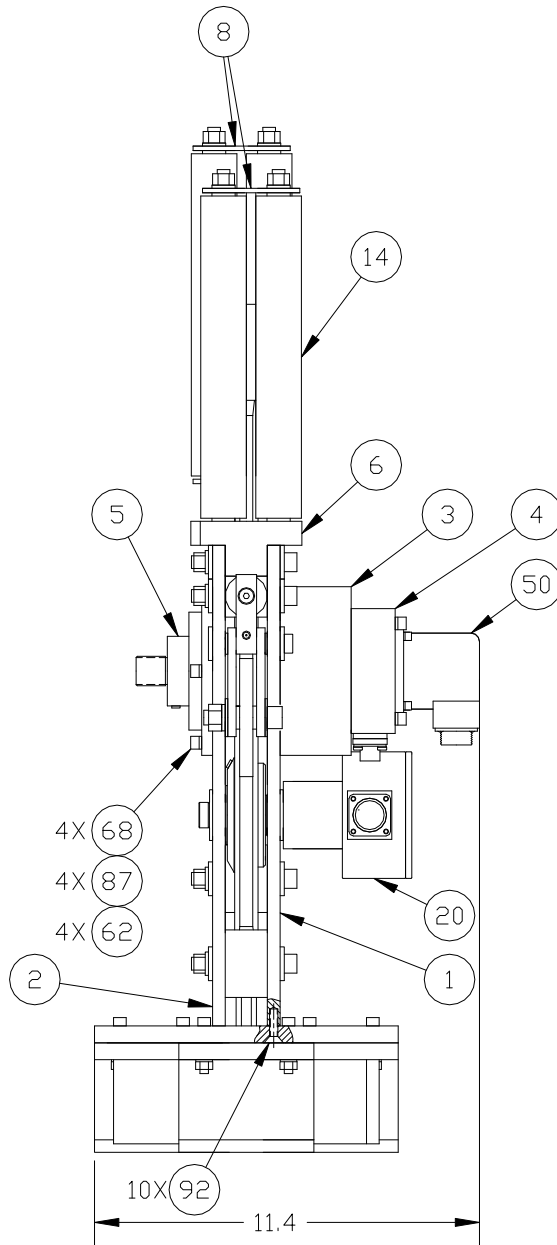

## MEASURE WHEEL CUTAWAY VIEW

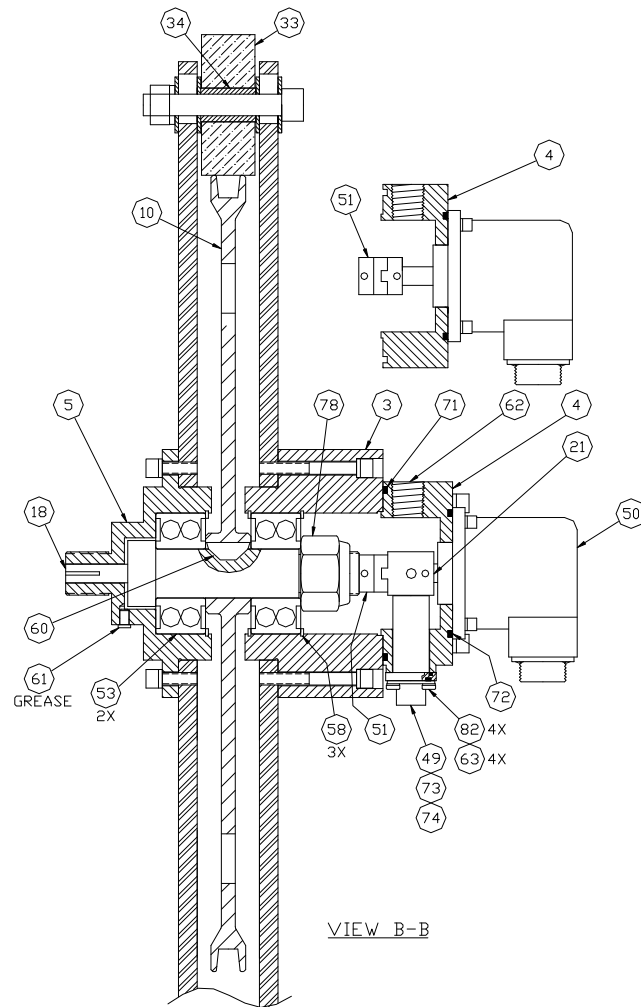

### TENSION WHEEL CUTAWAY VIEW

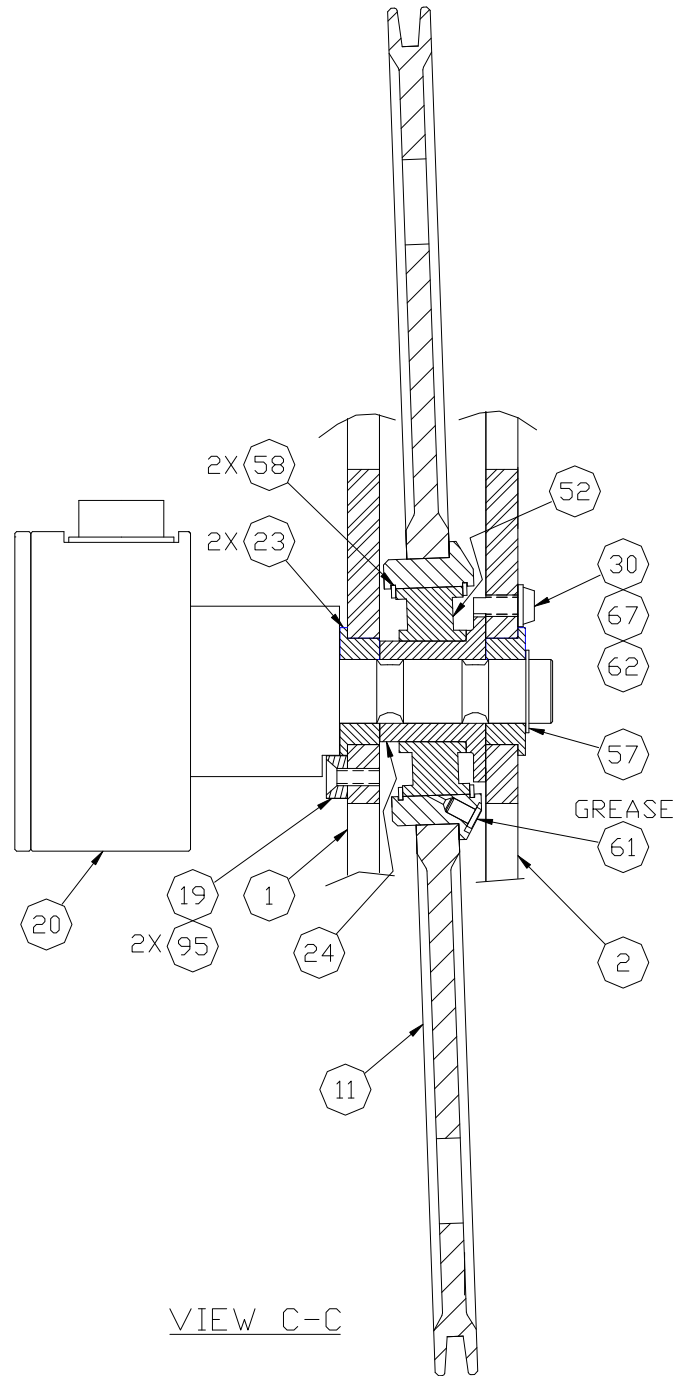



## MEASURE HEAD ASSEMBLY PARTS LIST

ITEM	P/N	DESCRIPTION	QTY	UM	REF
1	AMSLM045-1	PLATE SUPPORT VERT LEFT SIDE BOTTOM MT	1	EA	
2	AMSLM045-2	PLATE SUPPORT VERT RIGHT SIDE BOTTOM MT	1	EA	
3	AMSLM016	ADAPTER MEASURING WHL SHAFT ENCODER SIDE	1	EA	
4	AM3KM040	ADAPTER ENCODER H25D/H20 MAG BACKUP	0	EA	OPTION
4	AM5KM057	ADAPTER ENCODER H37C/H25D	1	EA	
5	AMSLM022	ADAPTER COUNTER HD RT ANGL DRV	1	EA	
6	AMSLM048	MOUNT GUIDE ROLLER 2 WHL CNTR	2	EA	
7	AMSLM039	PLATE BASE BOTTOM MOUNT 2-WHL	1	EA	
8	AMSLM021	PLATE SPACER GUIDE ROLLER VERT LEVELWIND	3	EA	
9	AMSLM044	BRACKET LEVELWIND CHAIN	2	EA	
10	AMSLM057	WHEEL MEASURING 4FT UNIV 2 WHL 0.092 -3/16	1	EA	
11	AMSLM012	WHEEL TENSION 4 FT 2 WHL CNTR	1	EA	
12	AMSLA033	WHEEL ASSY PRESS ROLLER TENSN W/BEARING	2	EA	
13	AMSLA034	WHEEL ASSY PRESS ROLLER MEASR W/BEARING	1	EA	
14	AMSLM019	ROLLER GUIDE VERT LEVELWIND	4	EA	
15	AMSLM049	GUIDE SPRING PRESS WHEEL 2WC	1	EA	
16	AMSLM050	MOUNT SPRING PRESS WHEEL 2WC	1	EA	
17	AMSLM051	MOUNT PIVOT PRESS WHEEL 2WC	1	EA	
18	AMSLM015	SHAFT MEAS WHL ENCDR/RT ANGLE	1	EA	
19	AMSLM085	PLATE ORIENTATION LOAD PIN	1	EA	
20	AMSLA010	ASSY LOAD AXLE 0-1.5V 3/4 DIA	OPT	EA	
20	AMSLP063	ASSY LOAD AXLE 2MV/V 3/4 DIA	OPT	EA	
20	AMSLA015	ASSY LOAD AXLE 4-20MA 3/4 DIA	OPT	EA	
21	AM3KM050	COUPLING ENCDR W/BKUP MAGNETS	0	EA	OPTION
22	AMSLM030	BUSHING FRAME 2 WHEEL COUNTER	6	EA	
23	AMSLM031	BUSHING TENSION WHEEL LOAD PIN	2	EA	
24	AMSLM035	BUSHING LOAD PIN W/ANTI-ROTATN	1	EA	
28	AMSLM052	PLATE SIDE PIVOT PRES ROLR 2WC	2	EA	
29	AMSLM018	TBG SPACER GUIDE ROLLER LVLWND	4	EA	
30	AMSLM084	SCREW ANTI-ROTATION TENS WHEEL	1	EA	
31	AMSLM053	BUSHING FLANGE PRESS WHEEL 3/8	1	EA	
32	AMSLM055	BUSHING FLANGE PRESS WHEEL 5/16	1	EA	
33	AMSLM033	ROLLER KEEPER UNIVERSAL	1	EA	
34	AMSLM034	SPACER KEEPER ROLLER UNIVERSAL	1	EA	
35	AMSLM040	SPACER FRAME 2 WHEEL COUNTER	3	EA	
36	AMSLM081	SPACER PRESSURE WHEEL 0.64 THK	2	EA	
37	AMSLM017	SPACER GUIDE ROLLER BTM LVLWND	2	EA	
49	AM5KA055	ASSY ENCODER BACKUP MAGNETIC	0	EA	OPTION
50	AMSLP061	ENCODER HD2.5D-0-SS-37F-1200-	1	EA	
51	AMS1P090	COUPLING OLDHAM ENCODER	0	EA	OPTION
51	C276M055	COUPLING ENCODER H25 TO RELIANCE ADTPR	1	EA	
52	AMSLP039	BEARING SPHERE-ROL 30MM ID W/SEALS	1	EA	

53	C276P001	BEARING BALL 25MM MRC5305- MZZ (CZZ)	2	EA	
54	AM3KP021	BEARING BALL 10MM FAFNIR 200PP	8	EA	
55	AMSLP005	BEARING PILLOW BLOCK 1-1/2 COMPENSATED	3	EA	
56	AMSLP009	BEARING BRZ FLANGED 3/8" ID X 1/4" OIL IMP	2	EA	
57	AMSLP033	RING RETNG EXT 0.750 SHAFT SST	1	EA	
58	AMSLP021	RING RETNG INT 2.440 MED DUTY	5	EA	
59	AMSLP078	SPRING COMP 2-1/4 OAL 1.218 OD	1	EA	
60	AMSLP015	KEY 1/4 X 7/8 WOODRUFF SST	1	EA	
61	AM5KP129	FITTING GREASE FLUSH STRAIGHT	3	EA	
62	C276P014	INSERT 1/4-20 HELI-COIL #R1185	13	EA	
63	C276P046	WASHER #6 LOCK SS	4	EA	
64	C276P035	WASHER #10 LOCK SS	4	EA	
65	AMS1P058	WASHER 3/8 LOCK SS	8	EA	
66	C276P513	WASHER 3/8 FLAT SST	16	EA	
67	C276P036	WASHER 1/4 LOCK SS	32	EA	
68	AM5KP144	WASHER 1/4 LOCK SS HIGH COLLAR	14	EA	
69	AMSLP047	WASHER 7/16 LOCK SST	3	EA	
70	AMSLP012	WASHER 7/16 FLAT SST	6	EA	
71	AMS1P014	O-RING 2-152 BUNA N ENC ADPTR	1	EA	ENCODER ADAPTER
72	AM5KP071	O-RING 2-141 BUNA N H25 ENCDR	1	EA	ENCODER
73	C276P042	O-RING 2-016 BUNA N IS L/P HSG	0	EA	BACKUP CONN
74	C276P041	O-RING 2-017 BUNA N L/P SLEEVE	0	EA	BACKUP HOUSING
75	AMS1P072	PLUG 3/8 NPT SS	1	EA	
75	C276P016	NUT 1/4"-20 HEX SS	12	EA	
76	AMS1P059	NUT 3/8-16 SST	12	EA	
77	AMSLP059	NUT 7/16-14 SST	3	EA	
78	C276P021	NUT 7/8-14 ELASTIC STOP SST	1	EA	
79	AMSLP055	SCREW 7/16-14 X 3 SOC HD	2	EA	
80	AMSLP094	ROD ALL-THREAD 3/8-16 SST	48	IN	
81	AMSLP060	SCREW 3/8-16 X 2-3/4 SOC HD SS	8	EA	
82	C276P331	SCREW 6-32 X 1/2 PHIL PAN SST	4	EA	
87	AMS1P048	SCREW 1/4-20 X 3/4 SOC HD SST	4	EA	
88	AM3KP027	SCREW 1/4-20 X 1-1/2 SOC HD SS	12	EA	
89	AMSLP025	SCREW 1/4-20 X 1 SOC HD SST	10	EA	
90	AM3KP026	SCREW 1/4-20 X 2 SOC HD CAP SS	4	EA	
91	AM3KP029	SCREW 1/4-20 X 1-3/4 SOC HD SS	4	EA	
92	C276P030	SCREW 1/4-20 X 1 FH SOC SST	10	EA	
93	AM5KP117	SCREW 1/4-20 X 5/8 BTN HD SST	1	EA	
94	AMSLP054	SCREW 7/16-14 X 1-3/4 SOC HD	1	EA	
95	AM5KP045	SCREW 10-24 X 1/2 FH SOC SST	4	EA	
96	AMS1P052	SCREW 10-24 X 5/8 SOC HD SST	4	EA	
96	AMS1P053	SCREW 10-24 X 2 SHCS SST	4	EA	
98	AMSLP023	BOLT SHOULDER 3/8 X 1-3/4 SST	1	EA	
99	AM5KP130	NOZZLE GREASE FITTING FLUSH	1	EA	

### 6.3 DIFFERENTIAL LOAD PIN

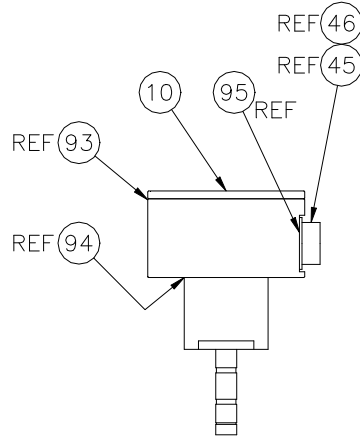

### AMSLA010 ASSY LOAD AXLE 1.5 V DIFFERENTIAL

45	AMS8P055	CONN KPT 02A16-8P	1 EA
46	AMS8P056	DUST CAP KPT81-16C	1 EA
93	C276P040	O-RING 2-235 BUNA N L/P LID 3-1/8 X 3-3/8 X 1/8	1 EA
94	AMS8P066	O-RING 2-136 BUNA N L/P HSG 1.98ID X 2.19OD X 0.103W	1 EA
95	AM5KP118	O-RING 2-023 BUNA N L/P CONN 1-1/16 X 1-3/16 X 1/16	1 EA





## 6.3 DIFFERENTIAL LOAD PIN (continued)

### AMS8A024 CABLE ASSEMBLY

#### DIFFERENTIAL TENSION FROM MEASURING HEAD TO PANEL



P/N	Description	Qty		
AMS8P057	CONN KPT06A16-8S STR PLUG	1	EA	LOAD PIN END
AMS7P014	CONN MS3106E-18-9S	1	EA	PANEL END
AMS4P221	CABLE 20/8C ALPHA -20 DEG	20	FT	
AMS7P060	DUST CAP SHELL SIZE 16	1	EA	LOAD PIN END

## 6.4 4-20MA CURRENT LOOP LOAD PIN

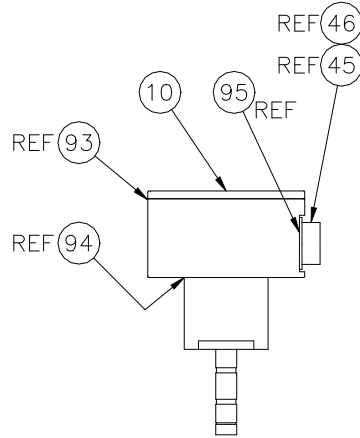

### AMSLA015 ASSY LOAD AXLE 4-20MA CURRENT LOOP

45	AMS7P013	CONN MS3102E-18-9P	1 EA
46	AMS1P029	DUST CAP MS25042-18DA	1 EA
93	C276P040	O-RING 2-235 BUNA N L/P LID 3-1/8 X 3-3/8 X 1/8	1 EA
94	AMS8P066	O-RING 2-136 BUNA N L/P HSG 1.98ID X 2.19OD X 0.103W	1 EA
95	AM5KP118	O-RING 2-023 BUNA N L/P CONN 1-1/16 X 1-3/16 X 1/16	1 EA

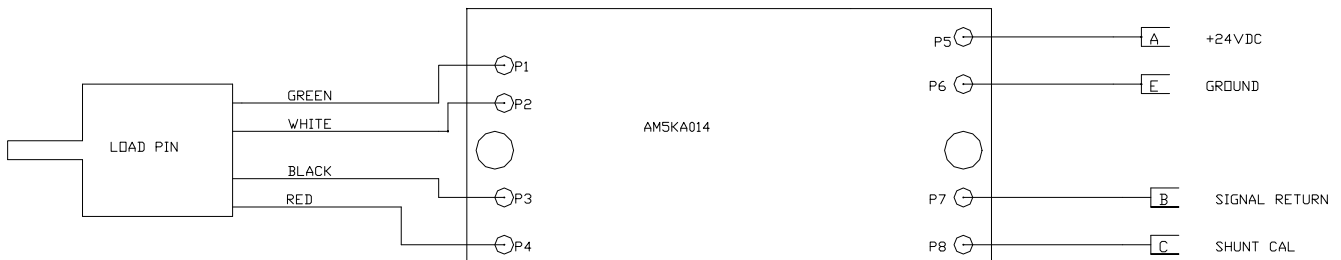

## 6.4 4-20MA CURRENT LOOP LOAD PIN (continued)

### AMS7A031 CABLE ASSEMBLY

### 4-20MA CURRENT LOOP TENSION CABLE FROM MEASURING HEAD TO PANEL

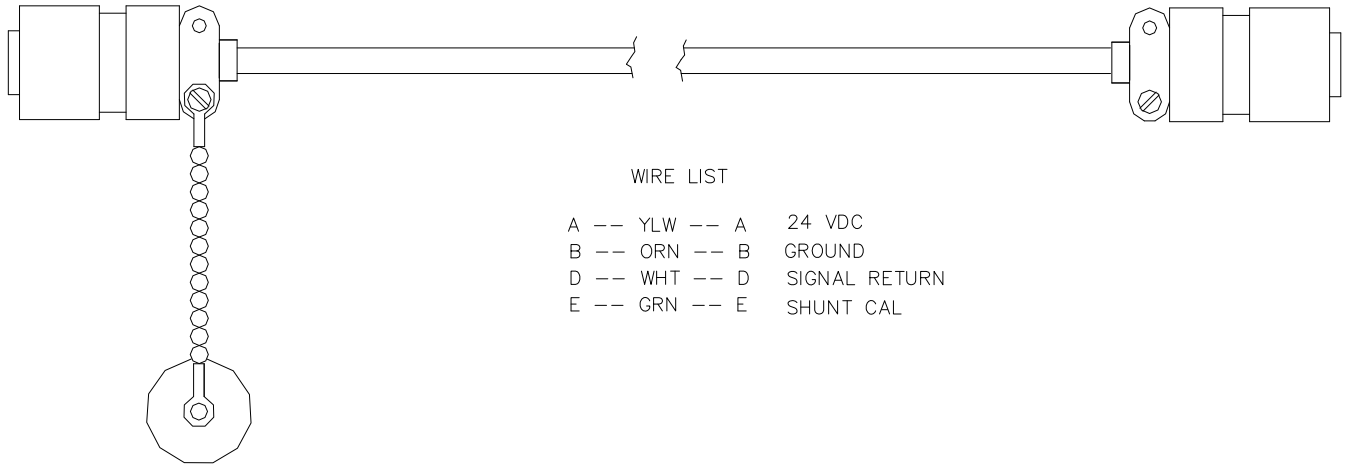

WIRE LIST

A	--	YLW	--	A	24 VDC
B	--	ORN	--	B	GROUND
D	--	WHT	--	D	SIGNAL RETURN
E	--	GRN	--	E	SHUNT CAL

P/N	Description	Qty		
AMS1P029	CONN MS25042-18 DA DUST CAP	1	EA	LOAD PIN END
AMS7P014	CONN MS3106E-18-9S	2	EA	
AMS4P221	CABLE 20/8C ALPHA -20 DEG	20	FT	

## 6.5 PASSIVE LOAD PIN

### AMSLP063 LOAD PIN

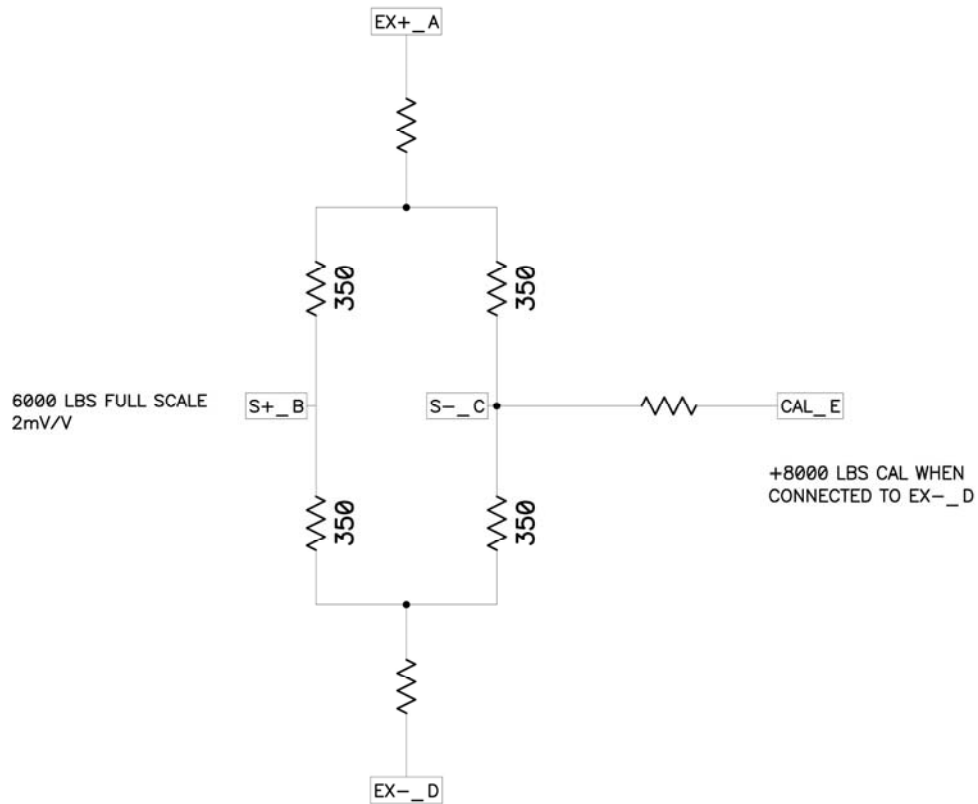

## AMS4A353 CABLE ASSY – PASSIVE LOAD PIN

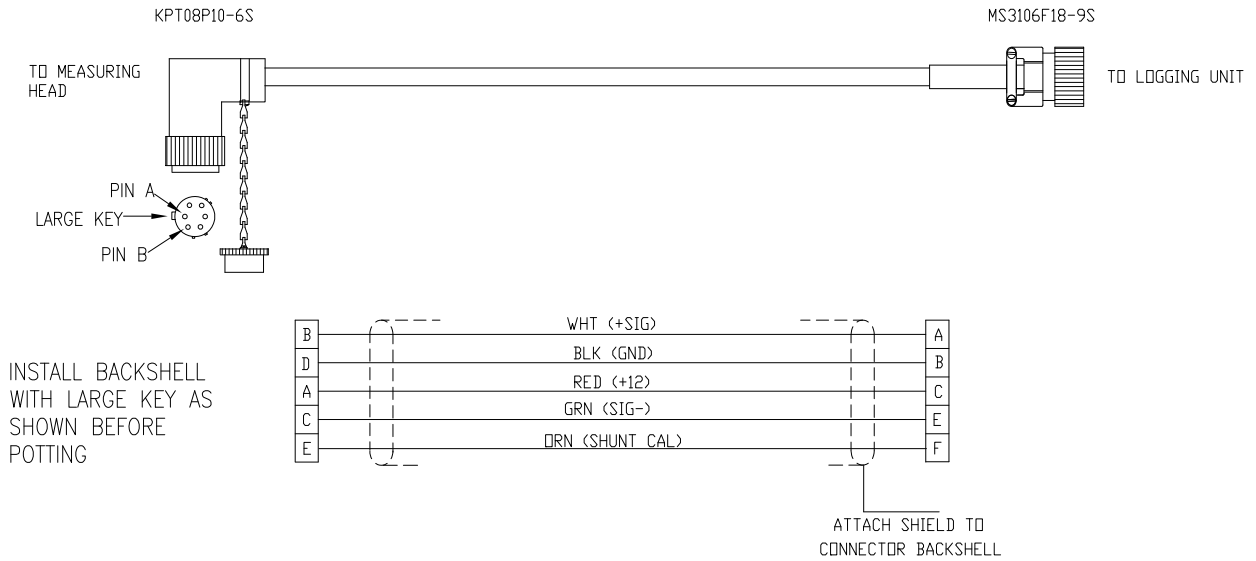

AM5KP058	CONN KPT08P10-6S RT ANGLE PLUG	1	EA	LOAD PIN END
AMS7P014	CONN MS3106E-18-9S	1	EA	
AM5KP059	DUST CAP KPT8010C CANNON	1	EA	
AMS4P221	CABLE 20/8C ALPHA -20 DEG	20	FT	

## 6.5 HI RESOLUTION ENCODERS

**AMSLP061 ENCODER HD2.5D-0-SS-37F-1200- ABZ-C-69-S-18-15-SPECIAL**

**AMS7P131 ENCODER HD2.5D-0-SS-37F-600-ABZ-C-69-S-18-15-SPECIAL**

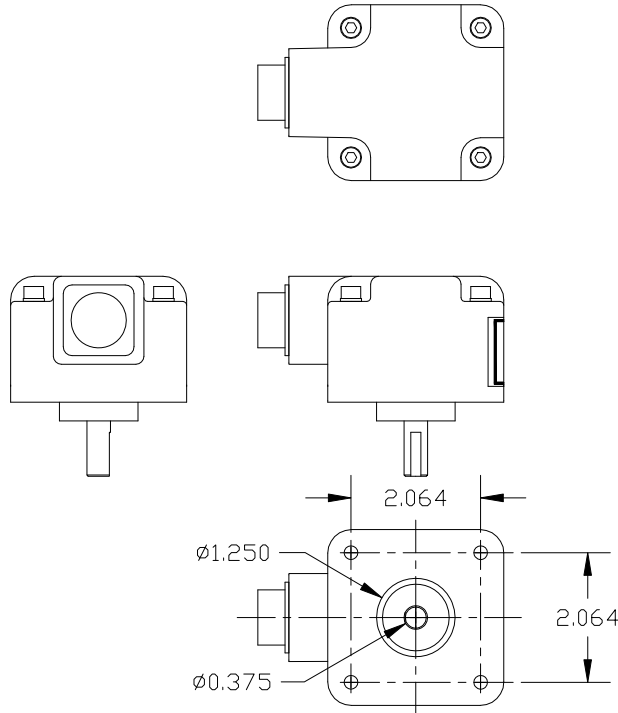

### Specifications

**600 or 1200 Pulses per revolution**

**5 – 15 vdc power**

**Differential Quadrature output (A – A not, B – B not)**

### Pin Out

A	-	A
H	-	A\
B	-	B
I	-	B\
D	-	+ 5v – 15 vdc
F	-	Gnd
G	-	Case

13	AMSLP061	ENCODER H25D-SS-1200-ABC-4469	1	EA
36	AM5KM073	COUPLING MOD ENCDR 0.250/0.375 BORE	1	EA
44	ACMU2P09	DUST CAP MS25043-18DA	1	EA

## Encoder Input Cable Drawing AMS4A125

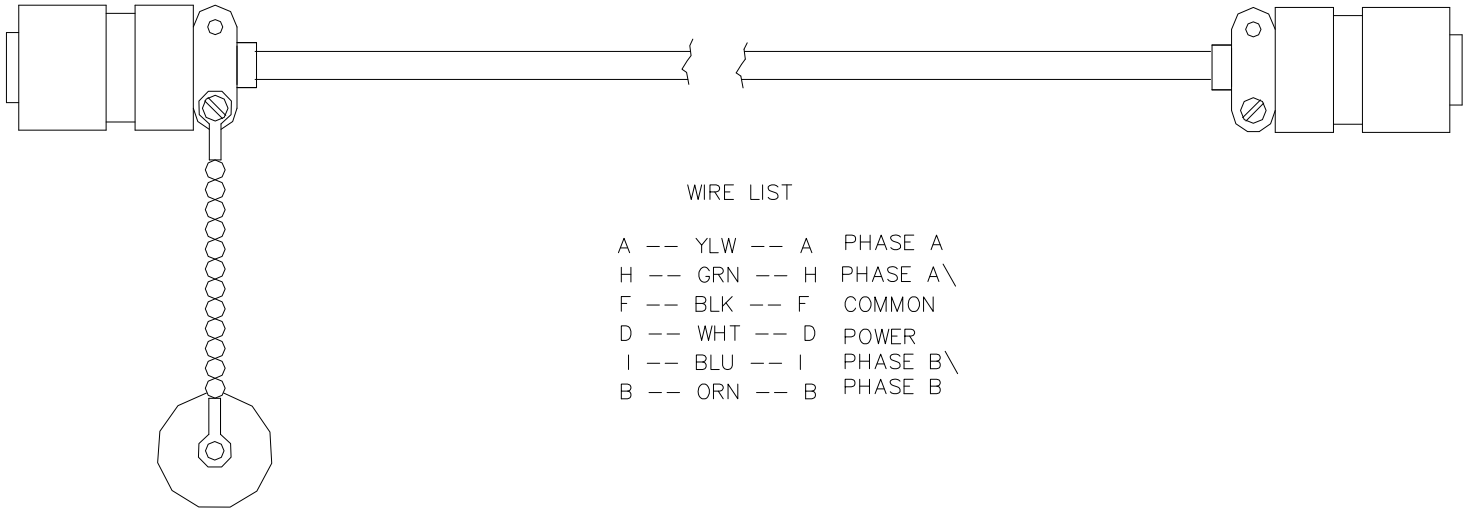

AMS1P028	CONN MS3106E-18-1S	2	EA	
AMS4P221	CABLE 20/8C ALPHA -20 DEG	20	FT	
AMS1P029	DUST CAP MS25042-18DA	1	EA	

## 6.6 BACKUP ODOMETER CABLE – AM5KA024-020

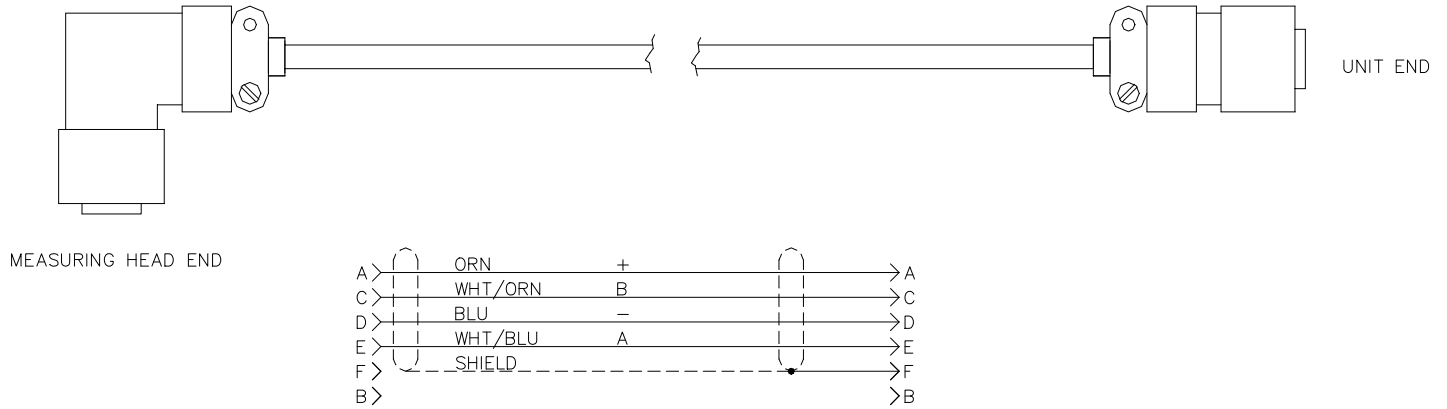

1	AMS4P222	CABLE 20/4C ALPHA -20 DEG	20	FT
2	AM5KP057	CONN KPT06F10-6P STR PLUG	1	EA
3	AM5KP058	CONN KPT08F10-6S RT ANGLE PLUG	1	EA
4	AM5KP059	DUST CAP KPT8010C CANNON	2	EA
5	AM5KA034	BUSHING #9779-513-4 AMPHENOL	2	EA



## 7.0 OPTIONAL ACCESSORIES

### 7.1 PIVOT PLATE

P/N AMSLA029

The pivot plate is designed to allow the measuring head to be pivoted 90 degrees when not in use. This allows it to fit inside a smaller compartment during transport.

It is a two piece assembly that sits between the measuring head and the horizontal spooling bars. The bearings are removed from the bottom of the measuring head and bolted to the bottom of the pivot plate.

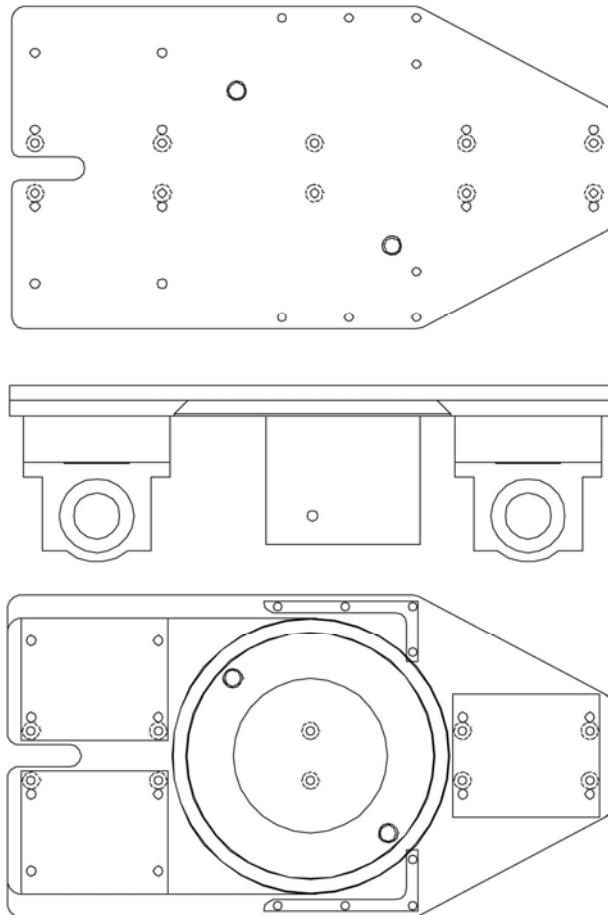

## 7.2 LOAD PIN REPLACEMENT PIN

P/N AMSLM013

In the event the load pin needs to be removed for calibration or repair, a pin can be inserted in its place to support the tension wheel.

At this time a hydraulic load cell can be used to provide tension. The depth portion of the measuring head will still function properly and accurately.

A 3/4" diameter shoulder bolt can be used as a substitute. The bolt needs to have at least a 2-1/2" shoulder. It should be of at least grade 8 to support the potential load.

