

## Direct Vent Gas Fireplace Installation Manual

Models:

**Modore 240**

**Tenore 240**

This appliance may be installed in an aftermarket permanently located, manufactured home (USA only) or mobile home, where not prohibited by local codes. This appliance is only for use with the type of gas indicated on the rating plate. This appliance is not convertible for use with other gases unless a certified kit is used.

### ⚠ **WARNING / AVERTISSEMENT / AVISO**

- HOT GLASS WILL CAUSE BURNS.
- DO NOT TOUCH GLASS UNTIL COOLED.
- NEVER ALLOW CHILDREN TO TOUCH GLASS.



- UNE SURFACE VITRÉE CHAUDE PEUT CAUSER DES BRÛLURES.
- LAISSER REFROIDIR LA SURFACE VITRÉE AVANT D'Y TOUCHER.
- NE PERMETTEZ JAMAIS À UN ENFANT DE TOUCHER LA SURFACE VITRÉE.

- EL VIDRIO CALIENTE CAUSARÁ QUEMADURAS.
- USTED DEBE NUNCA TOCAR EL VIDRIO CALIENTE.
- LOS NIÑOS DEBEN NUNCA TOCAR EL VIDRIO.

**WARNING:** If the information in these instructions is not followed exactly, a fire or explosion may result, causing property damage, personal injury, or death.

- Do not store or use gasoline or other flammable vapors and liquids in the vicinity of this or any other appliance.
- **WHAT TO DO IF YOU SMELL GAS:**
  - Do not try to light any appliance.
  - Do not touch any electrical switch; do not use any phone in your building.
  - Immediately call your gas supplier from a neighbor's phone. Follow the gas supplier's instructions.
  - If you cannot reach your gas supplier, call the fire department.
- Installation and service must be performed by a qualified installer, service agency or the gas supplier.

**AVERTISSEMENT :** Assurez-vous de bien suivre les instructions données dans cette notice pour réduire au minimum le risque d'incendie ou d'explosion ou pour éviter tout dommage matériel, toute blessure ou la mort.

- Ne pas entreposer ni utiliser d'essence ni d'autres vapeurs ou liquides inflammables dans le voisinage de cet appareil ou de tout autre appareil.
- **QUE FAIRE SI VOUS SENTEZ UNE ODEUR DE GAZ :**
  - Ne pas tenter d'allumer d'appareil.
  - Ne touchez à aucun interrupteur. Ne pas vous servir des téléphones se trouvant dans le bâtiment où vous trouvez.
  - Appelez immédiatement votre fournisseur de gaz depuis un voisin. Suivez les instructions du fournisseur.
  - Si vous ne pouvez rejoindre le fournisseur de gaz, appelez le service des incendies.
- L'installation et l'entretien doivent être assurés par un installateur ou un service d'entretien qualifié ou par le fournisseur de gaz.

## TABLE OF CONTENTS

Important Safety Information	3
Specifications and Dimensions	7
Clearances	13
Gas and Electric	19
Venting	23
Enclosing the Fireplace	33
Fire Media	37
Operating the Fireplace	42
Glass Cleaning	45
Installing the Screens	47
Maintenance	52
Warranty	54
Venting System Installation Instructions	Appendix One
Massachusetts Certification	Appendix Two
Troubleshooting Flowchart	Appendix Three

# IMPORTANT SAFETY INFORMATION

## CAUTION - HOT! HOT! HOT!

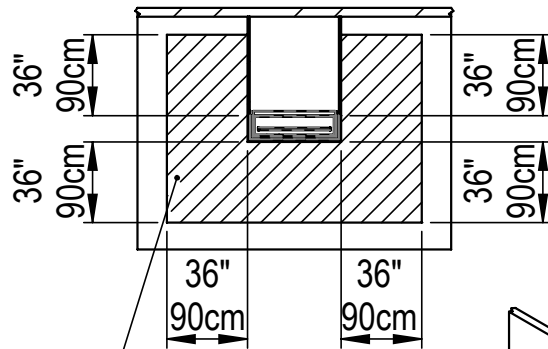
This appliance is a HEATING appliance and it does become very hot in operation. UNDER ANY CIRCUMSTANCES, DO NOT PLACE any furnishings, furniture, draperies or other item LESS THAN 36"/90 cm) IN FRONT OF THE GLASS OF THE FIREPLACE.

### CHILDREN AND PETS

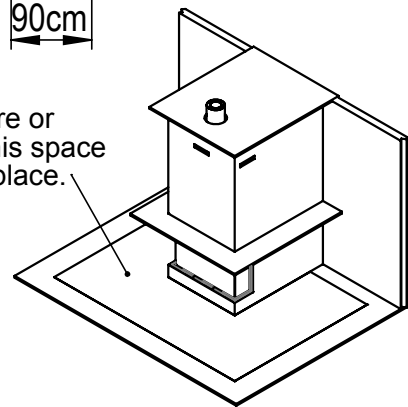
Radiant heat can heat surfaces such as the surround and trims of the fireplace to temperatures that, although approved safe, can be quite uncomfortable to touch - particularly for children and pets. Children and pets should always be supervised when in the room where the appliance is located. Remote control handset should be kept out of reach of children. In the presence of children, we STRONGLY RECOMMEND that you install in front of the fireplace: a fire screen or, to protect young toddlers, a "hearth gate".

### HOT SURFACES

Be aware that, although safe, some combustible materials and finishes, even though installed at listed clearances may, over time, discolor, warp or show cracks. Convective heat will exit the unit and travel up the wall surface if not impeded. Protruding mantels and projections can help direct the heat away from the wall. AVOID placing heat sensitive items such as televisions, paintings, decorations, etc. above fireplaces or near the edge of protrusions unless appropriate.



Do not put furniture or other objects in this space in front of the fireplace.



## SAVE THESE INSTRUCTIONS

Make yourself fully aware of all the following instructions and the many features of the Element4 direct vent gas fireplace appliance.

INSTALLER: Leave this manual with the appliance.

OWNER: Keep this manual for future reference.

# IMPORTANT SAFETY INFORMATION

## WARNING

Children and adults should be alerted to the hazards of high surface temperature and should stay away to avoid burns or clothing ignition.

## WARNING: Installation and Service

Installation and Service must be performed by an authorized qualified installer, service agency or gas supplier.

Any alteration to the product that causes soot or carbon to form and results in damage is not the responsibility of the manufacturer.

ONLY an authorized qualified installer may open the door/ remove the glass. The end user must NOT open the door/ remove the glass, as this may be unsafe and may result in voiding the manufacturer's warranty.

## WARNING

This direct vent system appliance must be installed as an OEM installation in manufactured homes (USA only) or an aftermarket permanently located, or a mobile home, **where not prohibited by local codes** and must be installed in accordance with Manufacturer's instructions and the Manufactured Home Construction and Safety Standard, Title 24 CFR, Part 3280, in the United States, or the Standard for Installation in Mobile Homes, CAN/CSA Z240 MH Series, in Canada.

If the information in these instructions is not followed exactly a fire or explosion may result causing property damage, personal injury or death.

Do not store or use gasoline or other flammable vapors and liquids in the vicinity of this appliance.

## WARNING: Electrical Grounding

These direct vent appliances must be electrically grounded in accordance with the local codes or, in the absence of local codes, with National Electric code, ANSI/NFPA 70, or the Canadian Electric Code, CSA C22.1

## WARNING: Gas Appliance

This appliance is only for use with the type of gas indicated on the rating plate. These appliances are not convertible for use with other gases, unless a certified kit is used and the conversion is performed by an authorized qualified technician.

Applicable standards are ANSI Z21.50/CSA 2.22 (Vented Gas Fireplaces) and CAN/CGA 2.17-M91 (Gas-fired Appliances for Use at High Altitudes.) If your installation is at an elevation greater than 2000' in the US or 4500' in Canada, consult with the local authority having jurisdiction for gas product installations to determine their specific requirements for high altitude installations.

## WARNING: Glass Handling

The glass must only be removed by an authorized and/or qualified installer. The authorized technician should only remove the glass by the use of glass vacuum holders.

# IMPORTANT SAFETY INFORMATION

This gas fireplace and vent assembly **MUST** be vented directly to the outside and **MUST NEVER** be attached to a chimney serving a separate solid fuel burning appliance. Each gas appliance **MUST BE** a separate vent system. Common vent systems are prohibited.

**TURN OFF** the gas before servicing the appliance. It is recommended that a qualified service technician perform an appliance check-up/service once a year.

Any safety screen or guard removed for servicing **MUST BE REPLACED** before operating this appliance.

This unit **MUST** be used with a vent system as described in this installation manual. **NO OTHER VENT SYSTEM OR COMPONENTS MAY BE USED.**

**THIS UNIT IS NOT FOR USE WITH SOLID FUEL**, and must only be used with gas supply conditions as indicated on the data label.

**INSPECT** the external vent cap on a regular basis to make sure that no debris, plants, trees, shrubs are interfering with the air flow.

**DO NOT USE** this appliance if any part has been under water. Immediately call a qualified service technician to inspect the unit and to replace any part of the control system and any gas control that has been under water.

**NEVER OBSTRUCT** the flow of ventilation air. Keep the front of the appliance **CLEAR** of all obstacles and materials for servicing and proper operation.

**DO NOT** use this heater as a temporary source of heat during construction.

This appliance is a **DOMESTIC ROOM HEATING APPLIANCE**. It must not be used for any other purposes such as drying clothes, etc.

The glass panels **MUST** be in place and sealed before the unit can be placed into safe operation.

**DO NOT OPERATE** this appliance with the glass panels removed, cracked or broken. Replacement of the glass panels should be performed by a licensed or qualified service person. **DO NOT** strike or slam the glass panels.

The glass panels **SHALL ONLY** be replaced by units supplied by the manufacturer. **NO SUBSTITUTE** panels shall be used.

**DO NOT USE** abrasive cleaners on the panels. **DO NOT ATTEMPT** to clean the glass panels when they are hot.

If the pilot flame is extinguished either intentionally or unintentionally, no attempt should be made to re-light the gas until at least 3 minutes have elapsed.

Dimensions will appear as **INCHES**/metric throughout this manual. For convenience, the inches are rounded to the nearest 1/16" when converted. If greater accuracy is required, use the metric dimensions.

# IMPORTANT SAFETY INFORMATION



When enclosing your Element4 fireplace the use of non-combustible building materials is **REQUIRED**. Please read and understand the following.

## COMBUSTIBLE MATERIALS

Materials that can catch fire and burn are considered combustible. Any material that is made of, or faced with, wood, wood pulp, paper, plastic or any other material that can catch fire and burn is considered combustible. Even though these materials may have been 'flame-proofed', made 'fire-resistant' or are 'fire-rated' they are considered combustible. Standard and Type X drywall are both combustible.

## NON-COMBUSTIBLE MATERIALS

A given material is said to be non-combustible when it cannot catch fire and burn. For example, materials made entirely, or in combinations, of, stone, brick, concrete, tile, steel, plaster or glass are considered non-combustible.

Table 1 shows a list of materials which, as of this writing, are reported by their manufacturers to be non-combustible (in accordance with the ASTM E136 standard) **AND** approved for use around fireplaces. Products which have a **YES** in **BOTH** the *Non-combustible* and *Manufacturer Approved* columns can be used with this fireplace.

<i>Product*</i>	<i>Non-combustible</i>	<i>Manufacturer Approved</i>
James Hardie Building Products HardieBacker® ¼" Cement Board	YES	YES
James Hardie Building Products HardieBacker® 500 Cement Board	YES	YES
Promat PROMATECT®-L Insulating Boards	YES	YES
Skamol Skamotec® 225 Fireplace Building Board	YES	YES
U.S. Architectural Products Versaroc® Cement Bonded Particle Board	YES	YES
U.S. Architectural Products Cem-Clad® Cement Panel	YES	YES
National Gypsum PermaBase® Cement Board	NO	NO
USG DUROCK® Cement Board Next Gen	YES	NO
CertainTeed Fiber Cement BackerBoard	NO	NO
Custom Building Products WonderBoard® Backerboard	NO	NO
Georgia-Pacific Gypsum DensGlass® Sheathing	YES	NO
Ameriform ARMOROC® Cement Bonded Particle Board	YES	NO

**Table 1**

\* The listed brand names are trademarks of their respective companies

# SPECIFICATIONS and DIMENSIONS

## APPLIANCE RATINGS

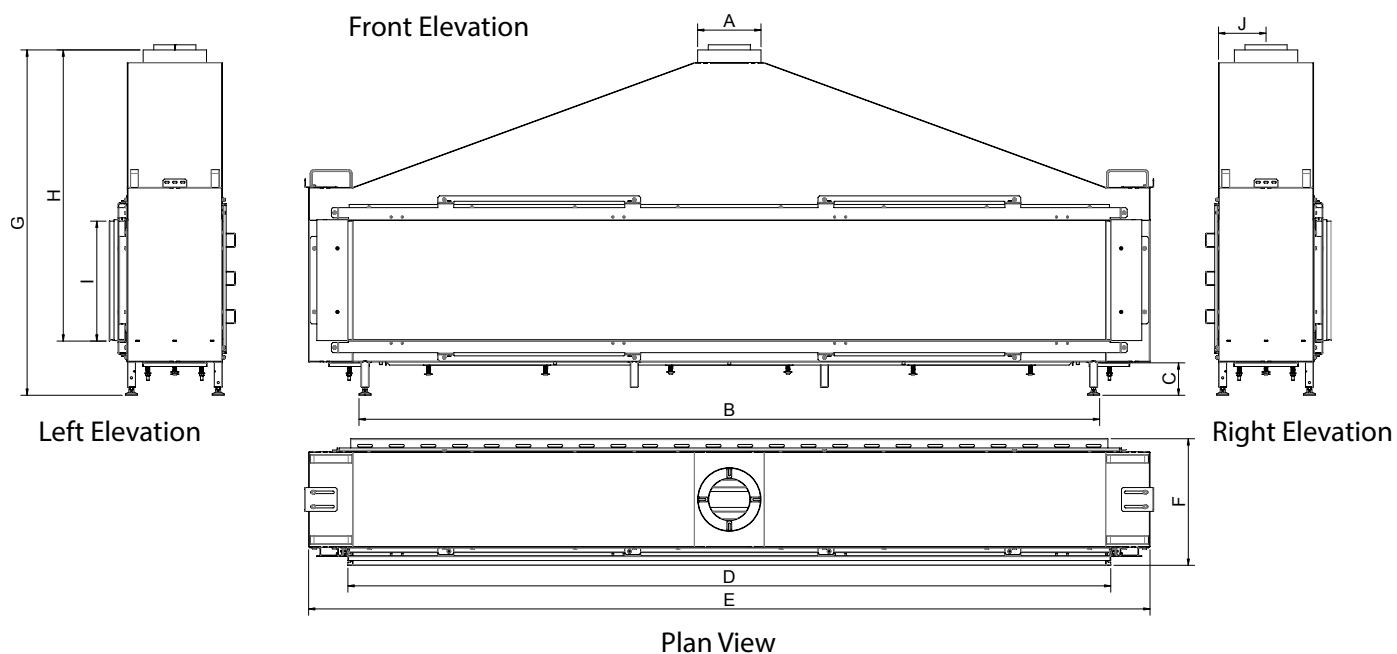
Model		Modore 240 Tenore 240	
Gas		Natural Gas	Propane
Input Maximum	Btu/hr	89,100	64,700
Input Minimum	Btu/hr	25,900	19,500
Maximum Supply Pressure	in. w.c.	7	11
	kpa	1.74	2.74
Minimum Supply Pressure	in. w.c.	4	8
	kpa	1	2
Manifold Pressure Maximum	in. w.c.	4.0	10.8
	kpa	0.99	2.68
Manifold Pressure Minimum	in. w.c.	0.4	1.5
	kpa	0.1	0.38
Main Burner Injector Marking		1200 (x3)	220 (x3)
Pilot Injector Marking		31.2	27.1

WALL ADAPTER SPECIFICATIONS	
Input Voltage	120V AC
Input Power	9 W
Output Voltage	6V DC
Output Current	500 mA
Size	3.1"H x 2"W x 1.7"D
Output Cord Length	6 Feet
Agency Approvals	UL, CSA



**Figure 1** Wall Adapter Connection (arrow)

# SPECIFICATIONS and DIMENSIONS

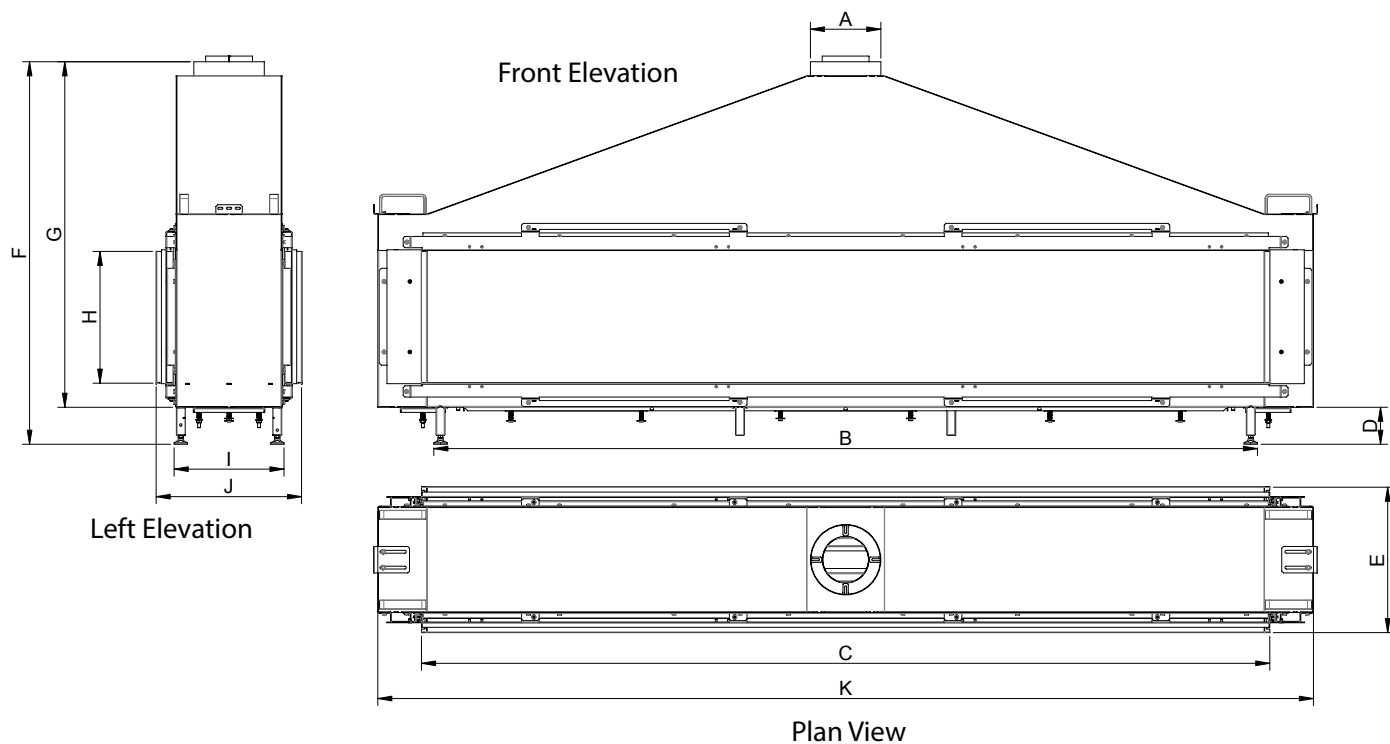


Letter	Inches	Millimeters
A	7 <sup>7</sup> / <sub>8</sub>	200
B	92 <sup>1</sup> / <sub>16</sub>	2338
C	4	102
D	94 <sup>13</sup> / <sub>16</sub>	2408
E	104 <sup>5</sup> / <sub>8</sub>	2656
F	15 <sup>5</sup> / <sub>8</sub>	398
G	42 <sup>13</sup> / <sub>16</sub>	1086
H	36	915
I	14 <sup>13</sup> / <sub>16</sub>	377
J	5 <sup>15</sup> / <sub>16</sub>	150

## MODORE 240



# SPECIFICATIONS and DIMENSIONS



Letter	Inches	Millimeters
A	7 <sup>7</sup> / <sub>8</sub>	200
B	92 <sup>1</sup> / <sub>16</sub>	2338
C	94 <sup>13</sup> / <sub>16</sub>	2408
D	4 <sup>3</sup> / <sub>16</sub>	105
E	16 <sup>5</sup> / <sub>16</sub>	413
F	42 <sup>13</sup> / <sub>16</sub>	1086
G	38 <sup>5</sup> / <sub>8</sub>	981
H	14 <sup>3</sup> / <sub>4</sub>	374
I	12 <sup>5</sup> / <sub>16</sub>	312
J	16 <sup>5</sup> / <sub>16</sub>	413
K	104 <sup>5</sup> / <sub>8</sub>	2656

## TENORE 240

# SPECIFICATIONS and DIMENSIONS


DO NOT REMOVE	NE PAS RETIRER	
<b>DIRECT VENT GAS FIREPLACE - Not for use with solid fuel.</b>	<b>FOYER GAZ À AÉRATION DIRECTE - Ne pas utiliser avec un combustible solide</b>	
<small>This appliance is only for use with the type of gas indicated on the rating plate and may be installed in an aftermarket, permanently located, manufactured home (USA only) or mobile home where not prohibited by local codes. See owner's manual for details. This appliance is not convertible for use with other gases, unless a certified kit is used.</small>	<small>Cet appareil est destiné uniquement avec le type de gaz indiqué sur la plaque signalétique et peut être installé dans une habitation en dur, à emplacement fixe (USA uniquement) ou dans une résidence mobile si la législation locale l'autorise. Consultez le manuel du propriétaire pour les détails. Cet appareil ne doit pas être modifié pour une utilisation avec d'autres gaz, sauf à l'aide d'un kit certifié.</small>	
<small>For use only with Vent, Glass Panels and Ceramic Logs (or stones) certified and approved for use with this appliance.</small>	<small>À utiliser uniquement avec des ventilations, panneaux en verre et poutres (ou pierres) en céramique dont l'utilisation est autorisée avec cet appareil.</small>	
<small>This appliance must be installed in accordance with local codes, if any; if none, follow ANSI Z223.1/NFPA 54, or CSA B149.1. The appliance must be properly connected to a venting system in accordance with the manufacturer's installation instructions. The system must be installed by a qualified installing agency.</small>	<small>Cet appareil doit être installé conformément à la législation locale. À défaut d'une telle législation, suivre ANSI Z223.1/NFPA 54, ou CSA B149.1. L'appareil doit être correctement raccordé à un système de ventilation, conformément aux instructions d'installation du fabricant. Le système doit être installé par un installateur qualifié.</small>	
Manufacturer / Fabricant Element4 P.O. Box 23 R.P. 7 The Netherlands / Pays-Bas Tel / Tél : +31 38 4209020 Fax: 0031 38 4209021	Approved By / Approuvé par:  No. : 4006611 Cert. to std. : ANSI Z21.50a-2008 Cert. to std. : ANSI Z21.50a-2008 - Vented Gas Fireplaces	
Product name: (check one) / Nom du produit : (cochez) Trisore 140 [ ] Bido 140 [ ] Modore 140 [ ]		
Serial No. / N° de série: _____		
This appliance equipped only for altitudes / Cet appareil est équipé uniquement pour les altitudes : 0-2000 ft / 0-0610 m		
Fuel Type / Type de combustible	Natural Gas / Gaz naturel	Propane Gas / Gaz propane
(check one) / (cochez...)	[ ]	[ ]
Max. Input / Capacité d'entrée maxi (BTU/HR)	38200	34100
Min. Input / Capacité d'entrée mini (BTU/HR)	13650	11950
Gas Inlet Pressure (in w.c.) / Pression d'entrée du gaz (en w.c.)	7	11
Manifold Pressure (in w.c.) / Pression d'admission (en w.c.)	2.5	10.8
Orifice Size / Taille de l'ouverture	1200	320
<b>Clearances to combustible / Dégage ment jusqu'au combustible :</b>		
Back / Arrière : 11" (28cm)	Sides / Côtés : 11" (28cm)	
Top / Haut : 26" (66cm)	Floor / Sol : 4" (10cm)	
Mantel / Linteau: 2" (5cm)		

Figure 2. Typical Rating Label

A typical rating label is shown in Figure 3. It is attached to every Element4 fireplace and contains important certification information. *It must not be removed from the fireplace.*

# SPECIFICATIONS and DIMENSIONS

## PARTS OF THE FIREPLACE

The various parts of the fireplace are shown in Figures 3, 4 and 5.

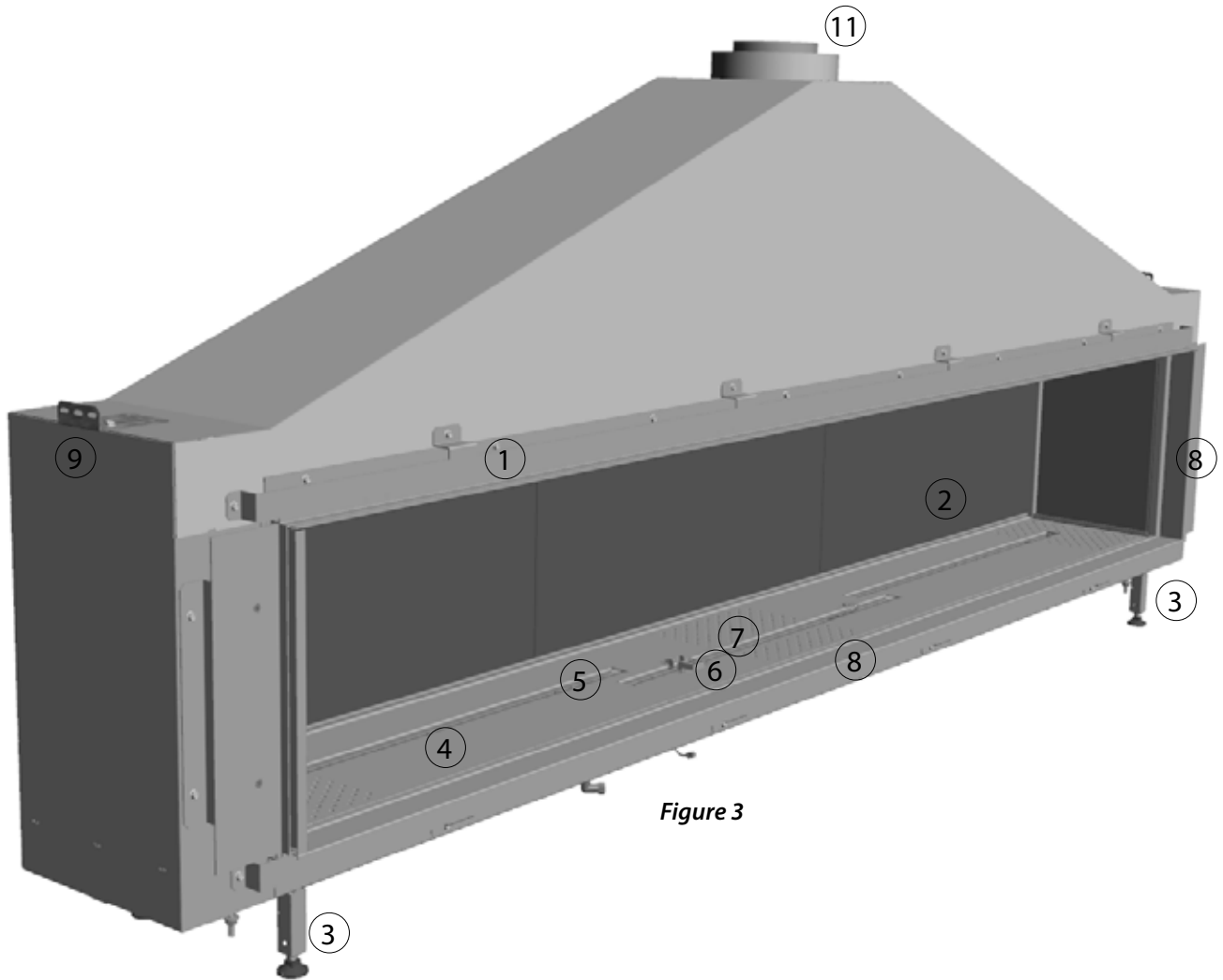


Figure 3

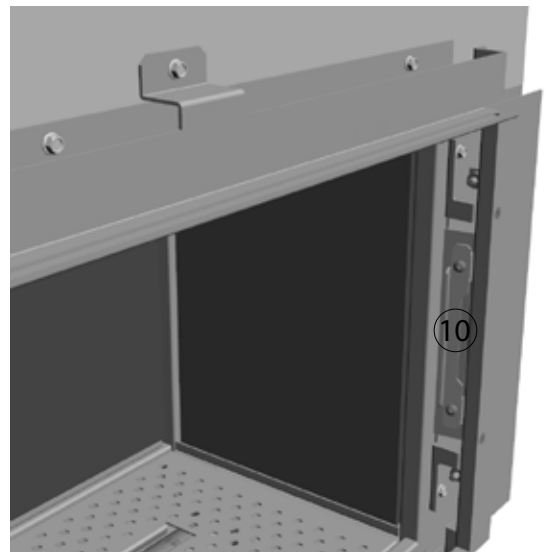


Figure 4

# SPECIFICATIONS and DIMENSIONS

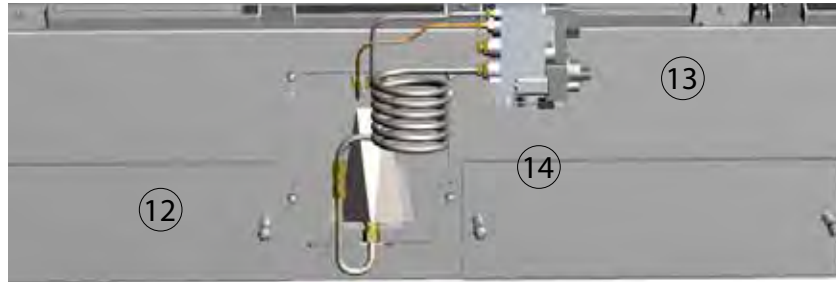


Figure 5

Figure 5 shows a bottom view. The Tenore and Modore are similar.

Table of Fireplace Parts	
①	Standoff Frame - surrounds the glass panels and limits the non-combustible wall board
②	Glass Panel - one, two or three, depending on model
③	Adjustable Foot - four adjustable feet allow the fireplace to be levelled
④	Hearth Panel - supports various Fire Media
⑤	Main Burner - produces the flame
⑥	Pilot Burner - the part of the safety circuit which lights the Main Burner
⑦	2 <sup>nd</sup> Thermocouple - the part of the safety circuit which monitors the Main Burner
⑧	Finish Trim - hides the Glass Clamps, the quantity varies by model
⑨	Fixing Bracket - attaches the fireplace to the building, the quantity varies by model
⑩	Glass Clamp - holds the Glass Panel in place, the quantity varies by model
⑪	Vent Collar - accepts the 5"/8" venting adapter (included)
⑫	Relief Door - part of the safety system, do not change or adjust, the quantity varies by model
⑬	Gas Control - is at the end of the Line Set ⑭ and controls the flow of gas. See Figure 57.
⑭	Line Set - approximately 51"/1.3 m long and is to be unwrapped to allow remote mounting of Gas Control

Table 2.

# CLEARANCES

The beauty of the Element4 fireplaces is due largely to the fact that they are NOT zero-clearance fireplaces. All clearances to combustible AND non-combustible materials MUST be maintained as described in this manual.

## LOCATION

When selecting a location for the fireplace:

- Ensure that all minimum clearances to combustible materials are met.
- Provide adequate clearances for servicing.
- The allowed venting dimensions (rise, run and number of bends, etc.) must be considered during the location selection for your fireplace.
- Due to high temperatures, the appliance should be located out of traffic and away from furniture and draperies.
- The location should also be free of electrical, plumbing or other heating/air conditioning ducting.

These appliances are intended to be built into a place for fire. The base upon which the appliance rests must be sturdy, level and built to safely support at least 500 pounds/230 kilograms. The base may be the floor or a purpose built raised platform (e.g. wood, metal). The base upon which the fireplace is installed must have a 2"/50 mm x 76"/1930 mm opening centered in it to allow the free flow of air to the fireplace above.

The feet on the appliance are designed to sit on a flat platform, however the appliance must not be installed on any combustible material other than wood. For example, carpet or linoleum bases are not permitted.

## MINIMUM CLEARANCE TO COMBUSTIBLES

- The appliance is approved with a minimum clearance to combustible materials on all sides of 11"/280 mm. Any spacer or framing used closer than this dimension must be non-combustible (e.g. metal). The minimum clearance to non-combustible material is 2"/50 mm.
- The minimum distance from the bottom of the appliance to the room ceiling is 72"/1830 mm.
- When installing the venting the following clearances to combustible materials MUST be maintained:
  - a. 3"/76 mm above any horizontal venting
  - b. 1"/25 mm to venting sides or below any horizontal venting
- Non-combustible materials may be installed to a zero clearance to the outer faces of the appliance outer frame. However, they must not cover (or prevent the removal of) the glass panels or the control equipment.
- Do not block or restrict the convection gap between the appliance firebox and the appliance outer frame (top of glass panels).

**The minimum clearances (air spaces) to combustible materials must be maintained. It is of the greatest importance that the fireplace and vent system be installed only in accordance with these instructions.**

Clearance to combustibles summary:

Back:	11"/280 mm
Sides:	11"/280 mm
Top:	26"/660 mm
Floor:	4"/100 mm

The **Floor** dimension (above) is measured from the bottom of the firebox thus the feet can sit on the floor and give this clearance in their lowest position.

# CLEARANCES

## MANTELS

The graph in Figure 7 shows a range of allowable depths and heights for a *combustible* mantel installation.

As shown, the minimum allowable mantel height above the fireplace opening is 2"/50 mm with a 1"/25 mm deep mantel.

The maximum mantel depth is 12"/300 mm at a minimum height above the fireplace opening of 13"/330 mm.

All of the mantel height/depth combinations fall in between these extremes in accordance with Figure 12.

Mantels made of *non-combustible* material are allowed inside these dimensions but they will be subjected to elevated temperatures and may be too hot to touch.

A typical completed installation with mantel is shown in Figure 7.

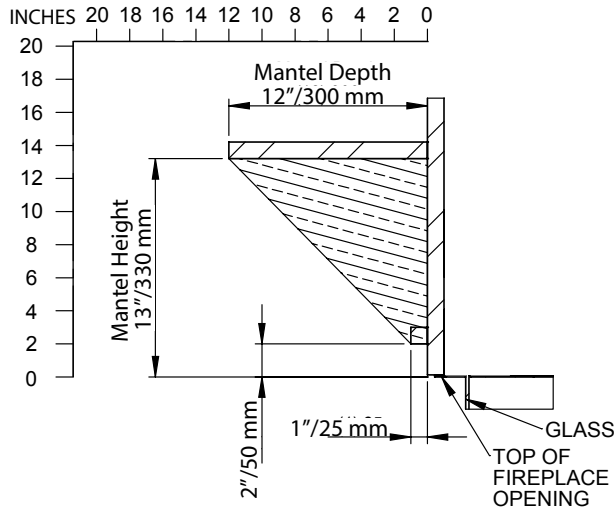


Figure 6

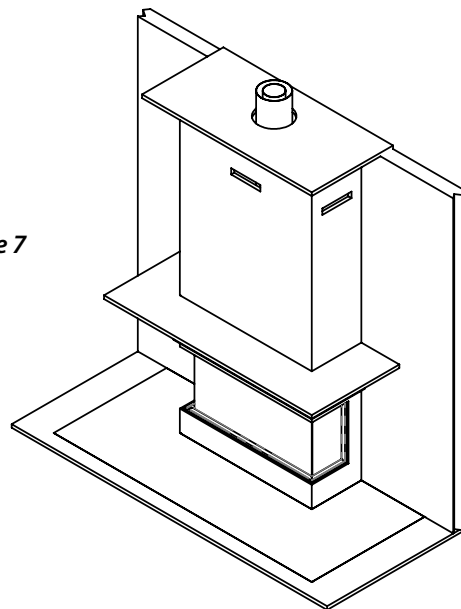


Figure 7

# CLEARANCES

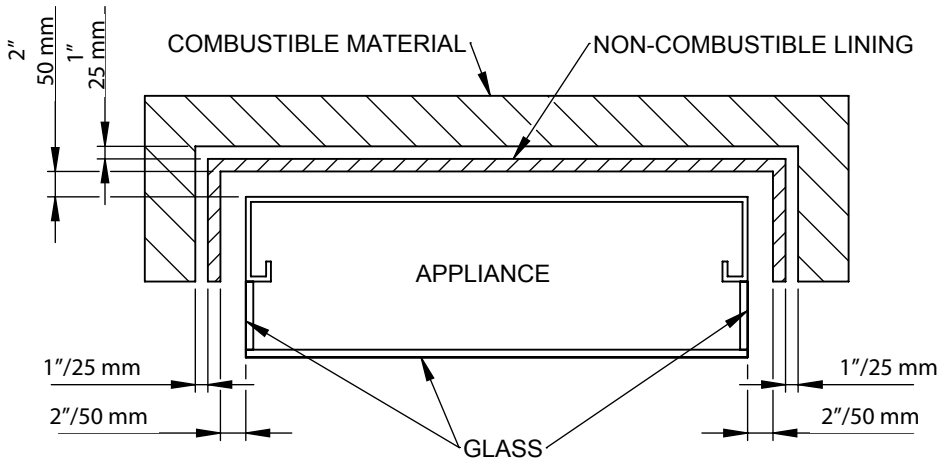


Figure 8 Plan View

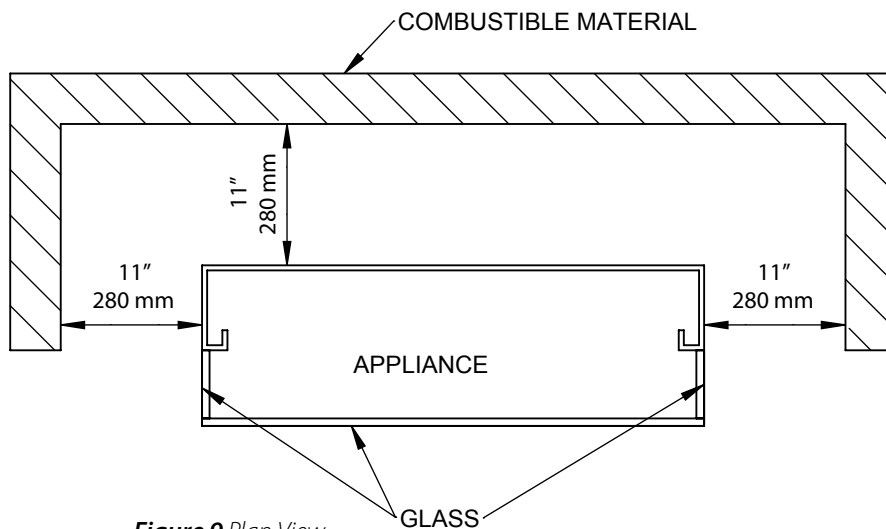


Figure 9 Plan View

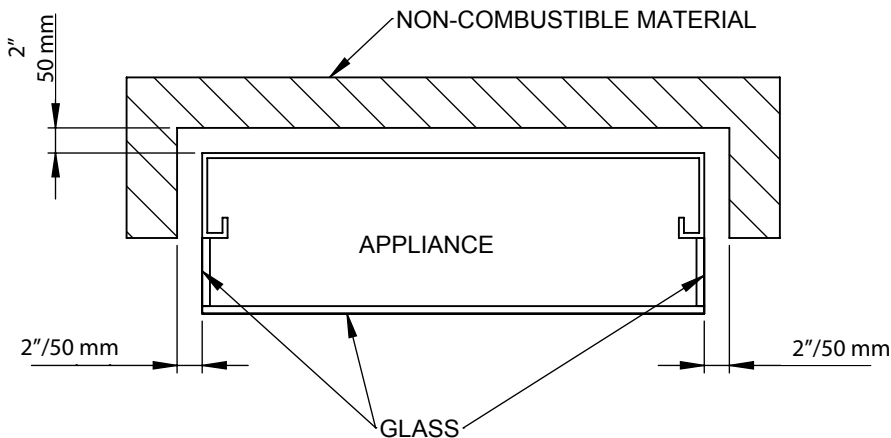


Figure 10 Plan View

## WITHIN COMBUSTIBLE AND NON-COMBUSTIBLE WALLS

Figures 8 through 10 show clearances to combustible and non-combustible walls.

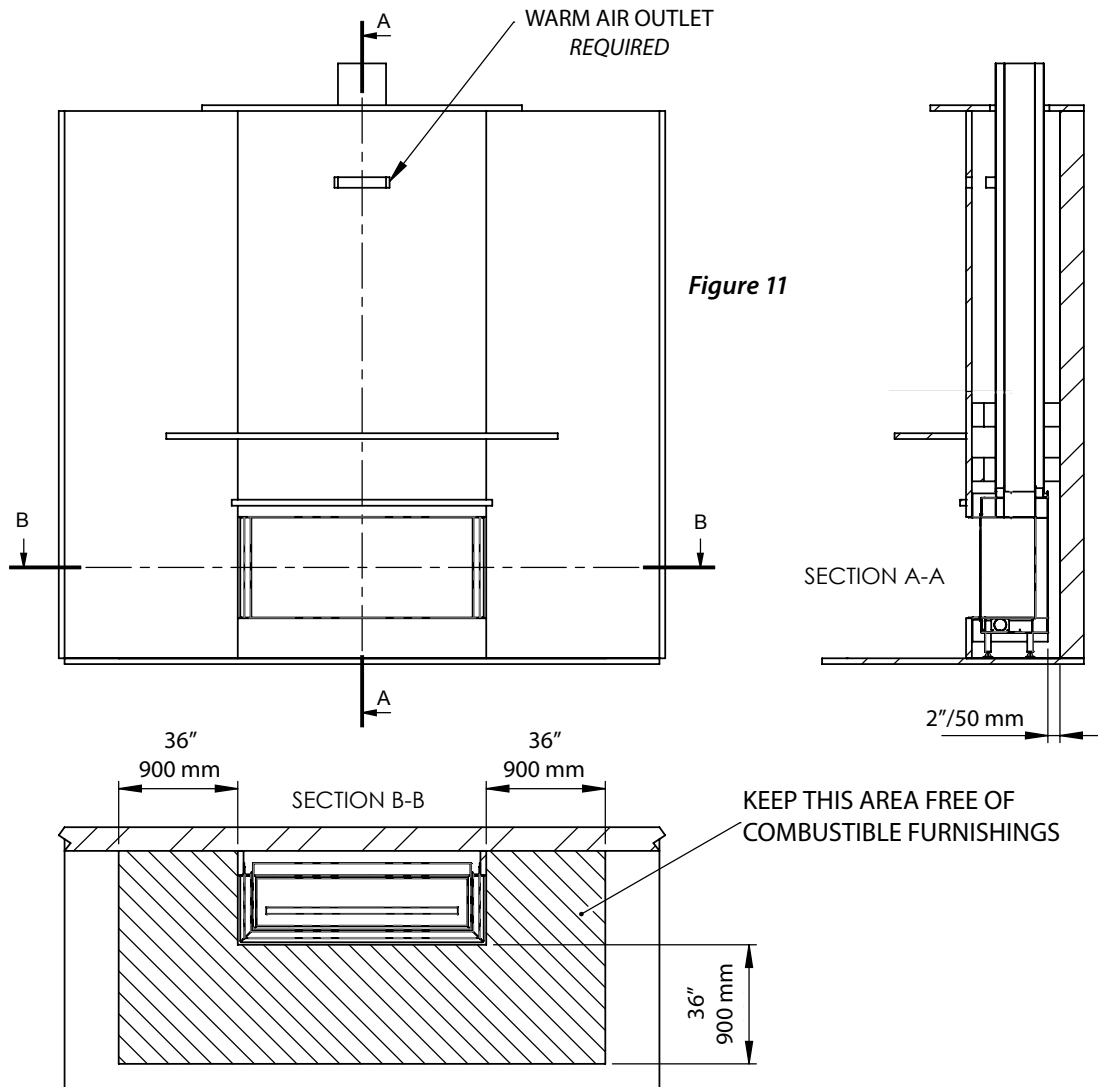
Figure 8 shows a typical method for protecting combustible walls while maintaining close installation dimensions. The non-combustible lining MUST extend more than 26"/660 mm above the top of the fireplace. The lining shall be placed no closer than 1"/25 mm to the floor or any intersecting walls. Air MUST be allowed to continually circulate around the lining.

Note: The 1"/25 mm and the 2"/50 mm air gaps MUST be maintained.

Figure 9 shows the minimum distance to combustible materials.

Figure 10 shows the minimum distance to non-combustible materials.

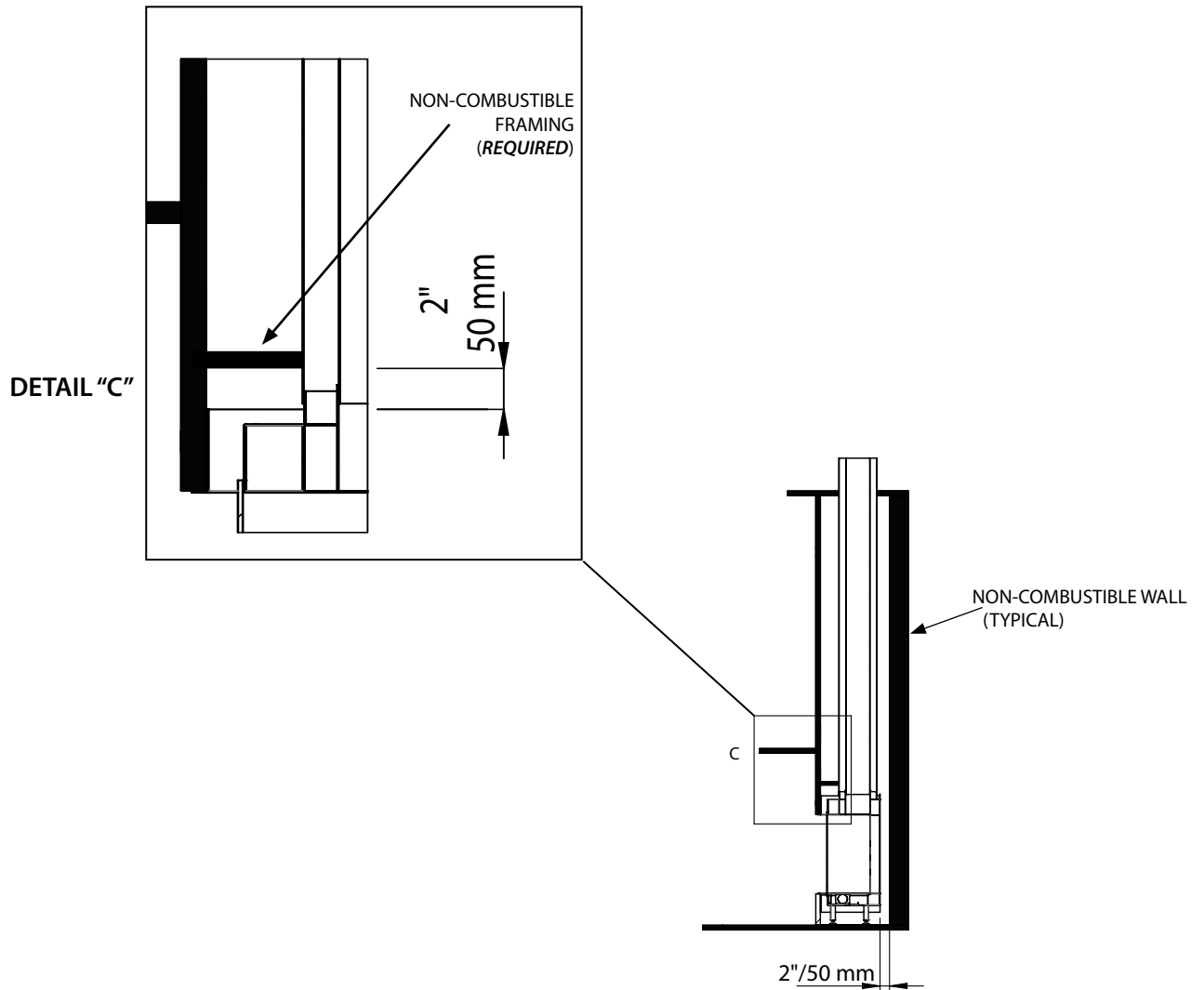
# CLEARANCES



A typical chase enclosing a Trisore fireplace (as an example) is shown in Figure 11. Section B-B (plan view) shows the area around the fireplace in which combustible furnishings are not permitted. Section A-A shows the clearance to NON-combustible materials. See **ENCLOSING the FIREPLACE** for the dimensions required for the Convection Air Outlet.



# CLEARANCES



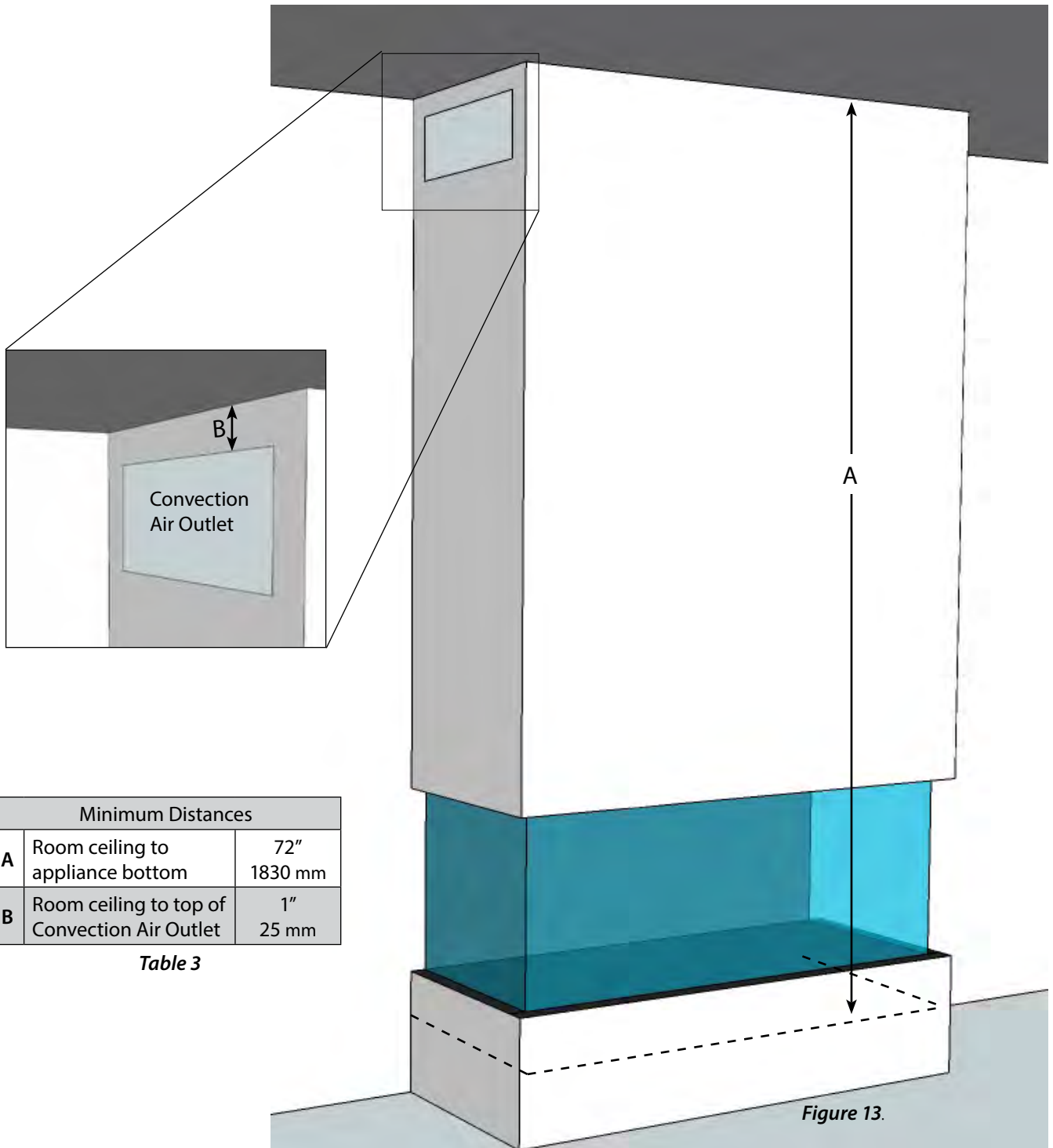
*Detail C* shows how the non-combustible framing above the fireplace maintains a minimum clearance of 2"/50 mm. This clearance **MUST** be maintained to ensure safe operation of the fireplace.

**Figure 12**

# CLEARANCES

## TYPICAL CLEARANCE DIAGRAMS

The total area of the convection air outlet(s) depends on the fireplace model. (See Table 7 on page 47.) The location of the outlet(s) must allow for the free movement of air and must not allow excessive convection air to build up within the chase. The top of the outlet(s) must be at least 1"/25 mm down from the ceiling and we recommend no more than 6"/152 mm down. The minimum distance from the bottom of the appliance to the room ceiling is 72"/1830 mm. See Table 3.



Minimum Distances		
A	Room ceiling to appliance bottom	72" 1830 mm
B	Room ceiling to top of Convection Air Outlet	1" 25 mm

Table 3

Figure 13.

# GAS and ELECTRIC

## INSTALLING THE GAS LINE

Correctly size and route the gas supply line from the supply regulator to the area where the appliance is to be installed as per requirements outlined in the latest edition of the National Fuel Gas Code, NFPA 54 (USA) or CAN/CSA-B149.1 (Canada).

Never use galvanized or plastic pipe unless specified specifically for use with gas. Refer to the table below for proper sizing of the supply gas line. Gas lines must be routed, constructed and made of materials that are in strict accordance with local codes and regulations. A qualified plumber or gas fitter should be hired to correctly size and route the gas supply line to the appliance.

Installing a gas supply line from the fuel supply to the appliance involves numerous considerations of materials, protection, sizing, locations, controls, pressure, sediment trap, and other criteria. The sizing and/or installing of gas piping should only be performed by a qualified plumber or gasfitter.

The gas control inlet accepts a  $\frac{3}{8}$ " NPT fitting.

Schedule 40 Black Iron Pipe		
	Natural Gas	Propane Gas
Length (feet)	Inside Diameter (Inches)	
0 - 10	$\frac{1}{2}$	$\frac{3}{8}$
10 - 40	$\frac{1}{2}$	$\frac{1}{2}$
40 - 100	$\frac{1}{2}$	$\frac{1}{2}$
100 - 150	$\frac{3}{4}$	$\frac{1}{2}$
150 - 200	$\frac{3}{4}$	$\frac{1}{2}$

*Table 4*

## ELECTRICAL REQUIREMENTS

The Element4 fireplaces use a receiver and remote control for their burner operation. The remote control comes with a 9V battery and the receiver is powered by a 120V AC wall adapter, included.

This installation must provide an approved 120V AC wall receptacle to be placed within the six foot cord limit of the wall adapter.

The receiver should be powered by either the wall adapter or 4AA batteries - not both. **Batteries do not provide an electrical backup for the wall adapter. Using batteries in combination with the wall adapter can damage the receiver.**



### WARNING

*Electrical work must be performed by a qualified, licensed electrician.*

*All wiring shall be in compliance with all local, city, and state codes.*

# GAS and ELECTRIC

## LOCATING THE CONTROLS

The control system for the Element4 fireplaces consist of three major components; the receiver, the transmitter and the gas control. The transmitter is the remote control by which you operate the fireplace. The receiver and the gas control are at one end of a line set which will extend approximately 16"/406 mm to the *left* of the fireplace. The other end of the line set is connected to the various components beneath the firebox. As shipped, the line set is wrapped together and fixed with cable ties beneath the fireplace. See Figure 14.

When locating the BDLE4 Access Door you must consider four types of access:

1. Air access. Room air must be allowed to flow freely through the Access Door perforations, up through the site-built platform and up into the enclosing fireplace chase.
2. Line set access. The line set is to be unwrapped which allows the controls to be placed within approximately 16"/406 mm from the left end of the fireplace, *as the cable runs*. Do not place the controls above the level of the burner.
3. Physical access. Is the gas valve/receiver accessible for maintenance, etc.?
4. Wireless access. Can the signals from the transmitter (handheld, remote control) get to the receiver, inside the access door?

## MOUNTING THE CONTROLS

The BDLE4 Access Door requires a rough opening of 9<sup>13</sup>/<sub>16</sub>"/250 mm high by 6<sup>15</sup>/<sub>16</sub>"/175 mm wide. The door should be mounted with the hinge on the left side. The door can also be mounted with the hinge side down.

- Carefully cut the black tie wraps which hold the line set to the bottom of the fireplace then carefully unwrap the line set. Lay the line set out towards the location of the BDLE4 while avoiding kinks and bends with a radius of less than 2"/50 mm.
- Remove the four bolts holding the white door/frame cover to the frame, separate the frame and cover then mount the BDLE4 frame to the rough opening as shown in Figure 15.
- Replace the white door/frame cover onto the frame and secure it with the four bolts
- Fit the gas control tab into the bracket on the BDLE4 frame then tighten the bolt through the mounting bosses . See Figures 16 and 17
- Set the receiver into the BDLE4 bracket as shown in Figure 18 and connect the wall adapter.

When mounted, the BDLE4 should look like that shown in Figure 19.

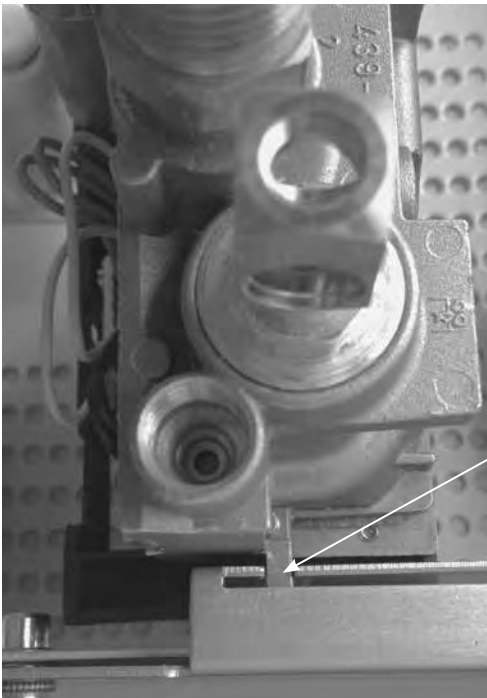
# GAS and ELECTRIC



One of the tie wraps which secure the line set.  
**Figure 14.**

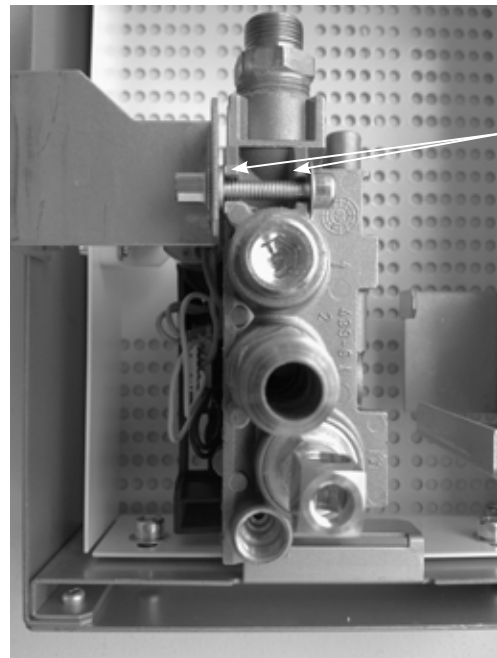


**Figure 15.**



Fit tab into  
bracket on BDLE4

**Figure 16**



Tighten bolt  
through  
mounting bosses  
(at arrows)

**Figure 17.**

# GAS and ELECTRIC



Figure 18



Figure 19

# VENTING

## CONFIGURING THE VENTING

The fireplaces in this manual are direct vent fireplaces that use a co-axial or “pipe within a pipe” venting system. The outer “pipe” or vent conducts fresh, outside air into the fireplace and the inner vent carries the exhaust outside. This technology, which can run either horizontally through a side wall or vertically through the roof, produces an efficient system because conditioned building air is not used for combustion.

**NOTE: The fireplaces described in this manual use 5”/8” venting.**

All of the following points apply to every installation:

- Only the direct vent components from M&G DuraVent (listed in Table 5) are approved for use with these fireplaces. The installation instructions are in Appendix One. Please read, understand and follow these instructions.
- Every Element4 fireplace is shipped with a North American venting adapter. It **MUST** be the first piece of venting installed.
- All measurements are taken from the center of the vent connector on the top of the fireplace (see *Figure 20*) and all configurations must fall within the acceptable range of the venting charts.
- The maximum allowable rise is 36’/11.0 m and the maximum allowable run is 9’10”/3.0 m but not in combination; see *Figure 21* and *Graph 1*.
- When venting with a horizontal termination, the minimum vent configuration is a 39”/1.0 m vertical rise to a 90° elbow plus a 19”/500 mm horizontal run to a wall termination. When venting with a vertical termination, the minimum vent configuration is 3’3”/1000 mm and the maximum rise is 36’/11.0 m maximum.
- When using wall terminations no more than two horizontal 45° or 90° elbows are allowed.
- When using vertical terminations no more than four 90° elbows OR eight 45° elbows OR a combination totaling no more than 360° ‘elbow degrees’. For example, a combination of two 90° elbows and two 45° elbows is allowed (90° + 90° + 45° + 45° equals 270°) but a combination of three 90° elbows and three 45° elbows is not allowed (the total equals 405°.) These elbows can be installed either horizontally or vertically.
- A minimum clearance of 3”/75 mm must be maintained between combustible materials and the top of any horizontal vent pipe surface; a minimum clearance of 1”/25 mm must be maintained between combustible materials and any other vent pipe surface.
- There may be no venting component higher than the termination.
- Whenever venting passes through a wall, a heat shield, or ‘wall thimble’ from the manufacturer listed in Table 5 must be installed.
- For venting configurations greater than those shown a power vent must be used. Contact your retailer for more details.

# VENTING

## MEASURING THE VENTING

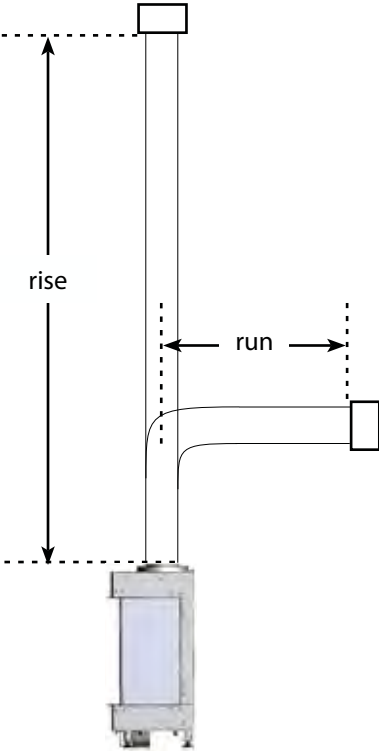


Figure 20

APPROVED MANUFACTURERS and COMPONENTS	
<i>Manufacturer</i>	<i>Modore, Tenore</i>
M&G DuraVent, Inc.*	only DirectVent Pro 5" x 8" components

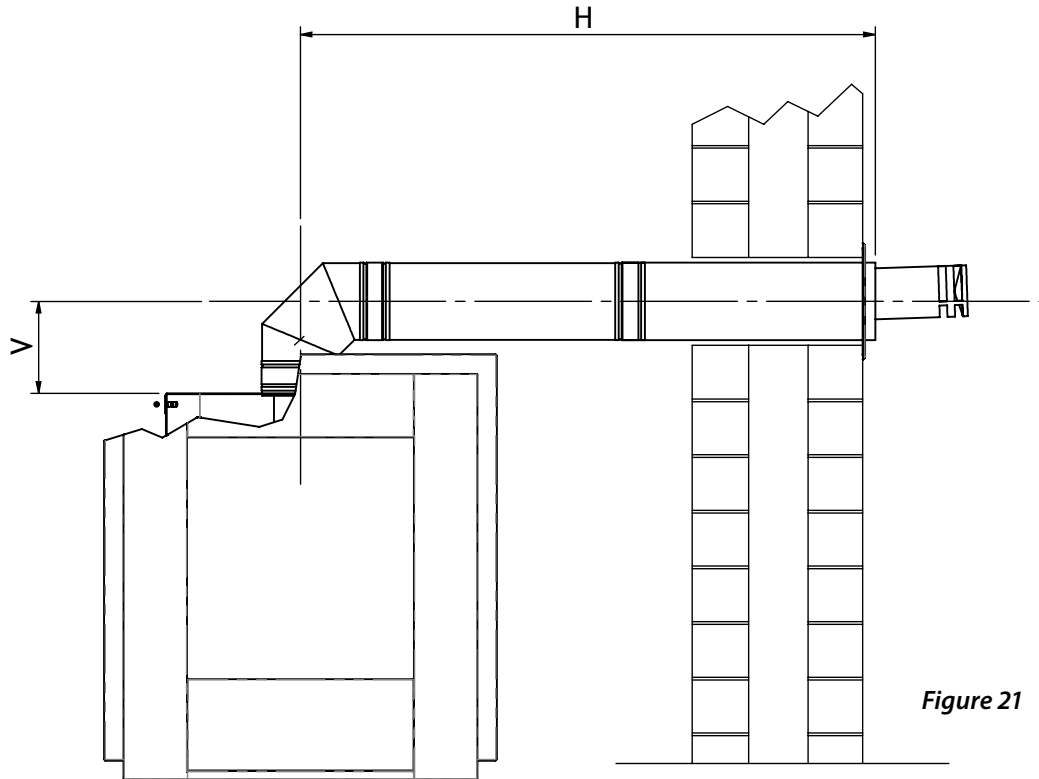
Table 5

\* Appendix One contains venting installation instructions.



# VENTING

## HORIZONTAL TERMINATION DIAGRAM

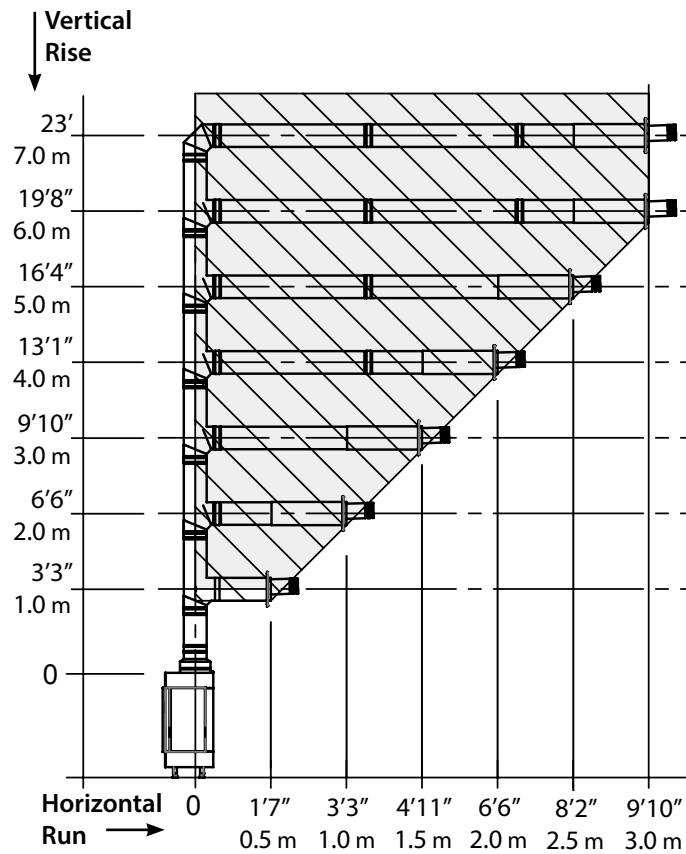


Dimension "H" can vary between 39"/1.0 m minimum to 9'10"/3.0 m maximum depending on Dimension "V". See Graph 1.

Dimension "V" can vary between 39"/1.0 m minimum to 23'/7.0 m maximum depending on Dimension "H". See Graph 1.

# VENTING

## HORIZONTAL TERMINATION GRAPH



**Graph 1.** Horizontal Terminations

Graph 1 shows, for all models, the maximum horizontal vent run (to the outside wall) for a given vertical vent rise. The installed venting configuration **MUST** be within the dimensions shown within the grayed area.

When using a wall-mounted termination a maximum of 2 horizontally-mounted elbows (45° or 90°) may be used.

- For each 45° elbow, 20"/500 mm must be subtracted from the horizontal length allowance.
- For each 90° elbow, 40"/1000 mm must be subtracted from the horizontal length allowance.

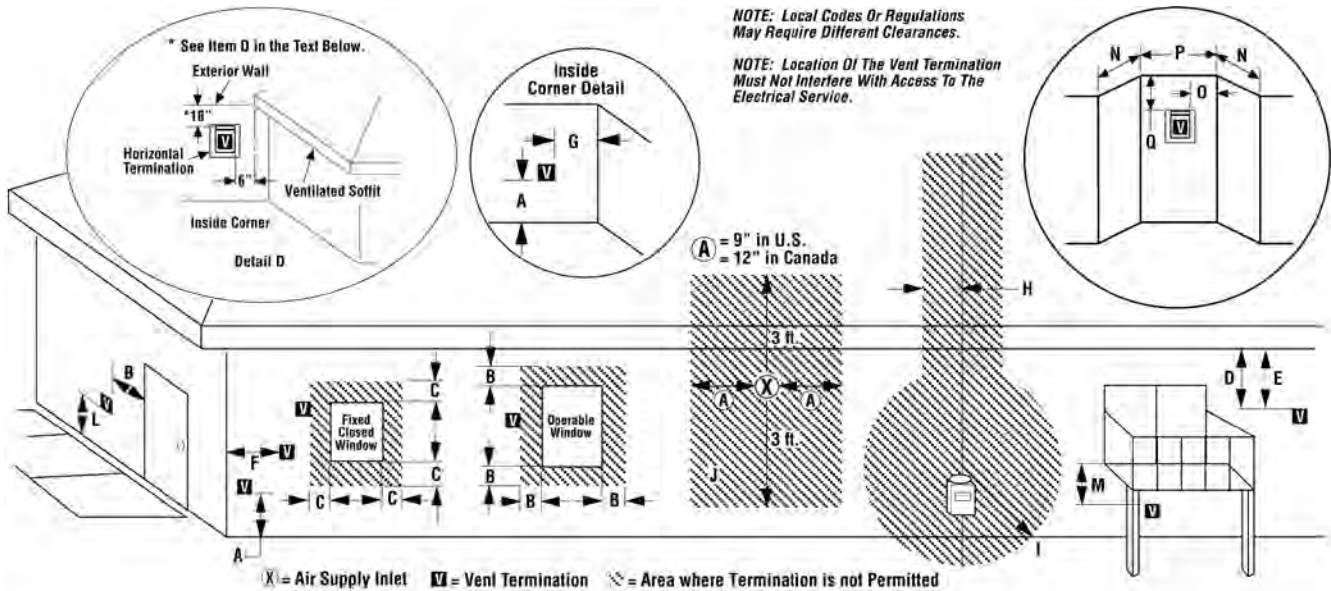
Example A: With a total rise of 6'6"/1.5 m and one horizontal 90° elbow, a total run of 3'3"/1.0 m is allowed

Example B: If the rise is 16'4"/5.0 m then the run can be no longer than 8'2"/2.5 m.

Example C: If the run is 4'11"/1.5 m then the rise must be at least 9'10"/3.0 m.

# VENTING

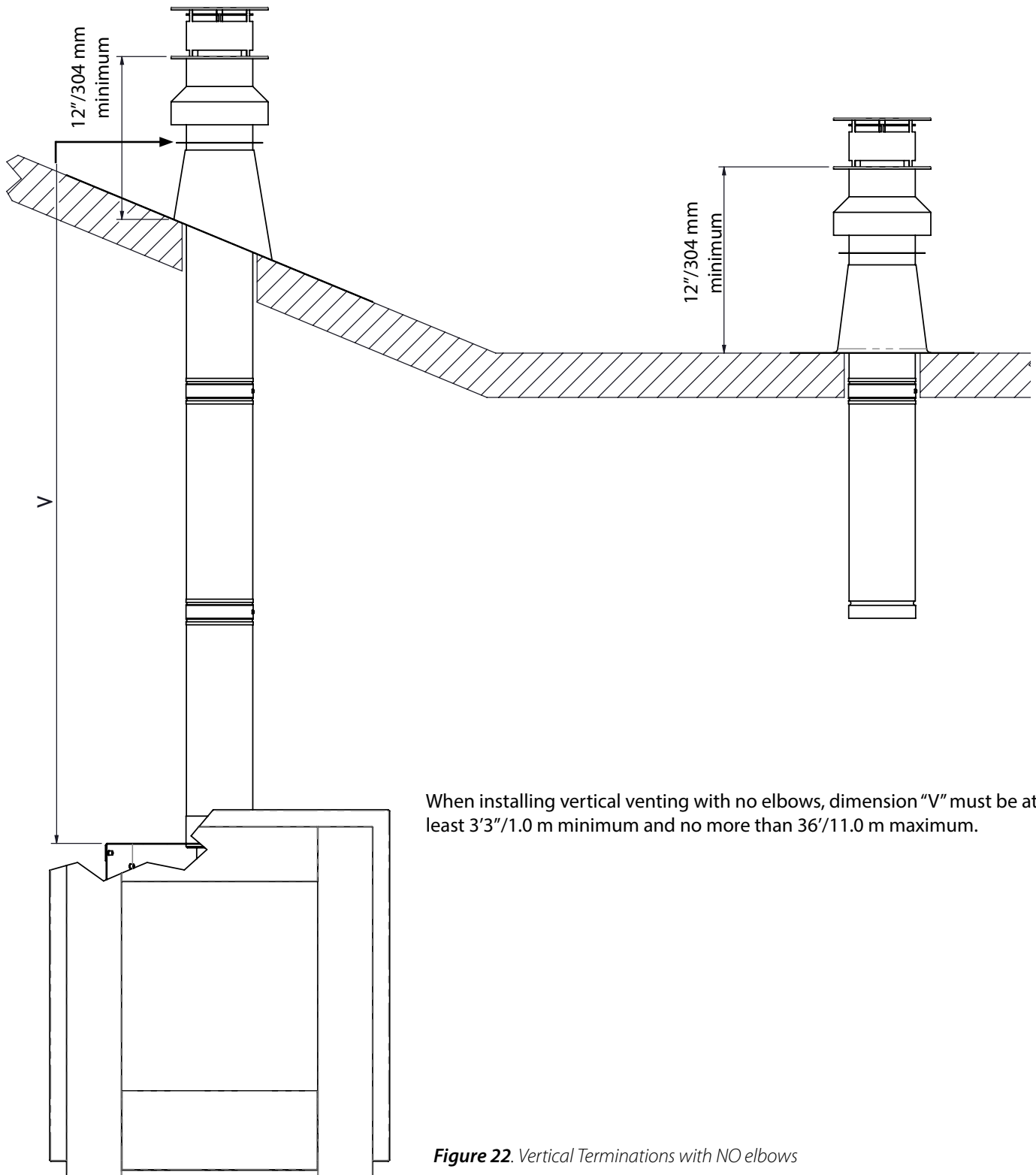
## HORIZONTAL VENT TERMINATION CLEARANCES AND REQUIREMENTS



	Canadian Installation*	US Installation**
A = Clearance above grade, veranda, porch, deck, or balcony.	12 inches (30cm)*	12 inches (30cm)**
B = Clearance to window or door that may be opened.	6 inches (15cm) for appliances < 10,000 Btuh (3kW), 12 inches (30cm) for appliances > 10,000 Btuh (3kW)	6 inches (15cm) for appliances < 10,000 Btuh (3kW), 9 inches (23cm) for appliances > 10,000 Btuh (3kW) and < 50,000 Btuh (15kW), 12 inches (30cm) for appliances > 50,000 Btuh (15kW)**
C = Clearance to permanently closed window	12 inches (305mm) recommended to prevent window condensation	9 inches (229mm) recommended to prevent window condensation
D = Vertical clearance to ventilated soffit located above the termination within a horizontal distance of 18 inches (458mm) from the center line of the termination	18 inches (458mm)	18 inches (458mm)
E = Clearance to unventilated soffit	12 inches (305mm)	12 inches (305mm)
F = Clearance to outside corner	5 inches (12.7cm) minimum	5 inches (12.7cm) minimum
G = Clearance to inside corner	2 inches (5.08cm) minimum - SV4.5HT-2	2 inches (5.08cm) minimum - SV4.5HT-2
H = Clearance to each inside of center line extended above meter/regulator assembly	3 feet (91cm) within a height of 15 feet above the meter/regulator assembly*	3 feet (91cm) within a height of 15 feet above the meter/regulator assembly**
I = Clearance to service regulator vent outlet	3 feet (91cm)*	3 feet (91cm)**
J = Clearance to nonmechanical air supply inlet to building or the combustion air inlet to any other appliance	6 inches (15cm) for appliances < 10,000 Btuh (3kW), 12 inches (30cm) for appliances > 10,000 Btuh (3kW)	6 inches (15cm) for appliances < 10,000 Btuh (3kW), 9 inches (23cm) for appliances > 10,000 Btuh (3kW) and < 50,000 Btuh (15kW), 12 inches (30cm) for appliances > 50,000 Btuh (15kW)**
K = Clearance to a mechanical air supply inlet	6 feet (1.83m)*	3 feet (91cm) above if within 10 feet (3m) horizontally**
L = Clearance above paved sidewalk or paved driveway located on public property	7 feet (2.13m)‡	7 feet (2.13m)‡
M = Clearance under veranda, porch, deck or balcony	12 inches (30cm)*‡	12 inches (30cm)‡
N = Depth of Alcove (Maximum)	6 feet (1.83m)*	6 feet (1.83m)**
O = Clearance to Termination (Alcove)	6 inches (15.2mm)*	6 inches (15.2mm)**
P = Width of Alcove (Minimum)	3 feet (91cm)*	3 feet (91cm)*
Q = Clearance to Combustible Above (Alcove)	18 inches (457mm)*	18 inches (457mm)**
* In accordance with the current CSA-B149.1 National Gas And Propane Installation Code.		
** In accordance with the current ANSI S223.1/NFPA 54 National Fuel Gas Codes.		
‡ A vent shall not terminate directly above a sidewalk or paved driveway which is located between two single family dwellings and serves both dwellings.		
*‡ Only permitted if veranda, porch, deck or balcony is fully open on a minimum 2 sides beneath the floor:		

# VENTING

## VERTICAL VENT TERMINATIONS

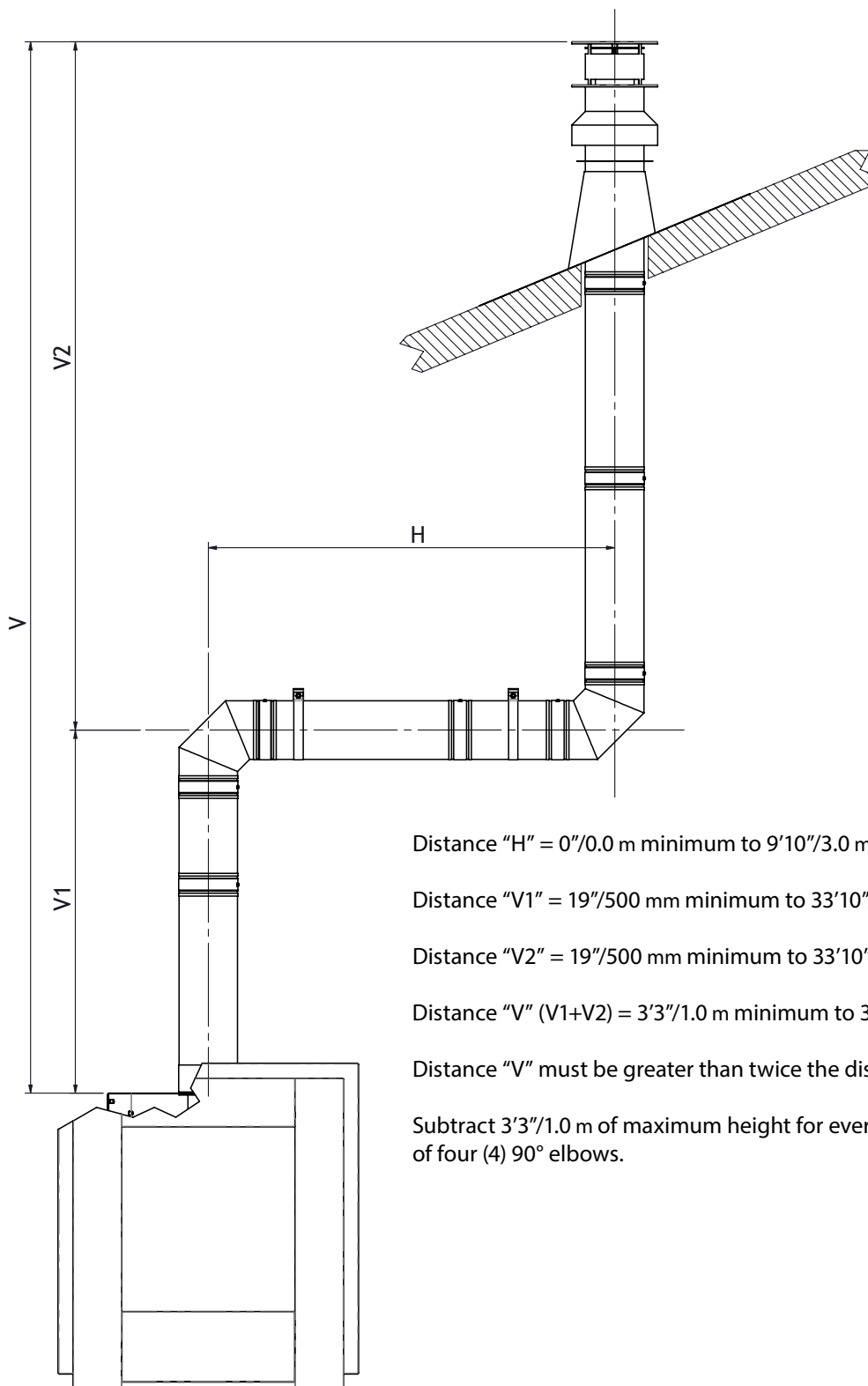


When installing vertical venting with no elbows, dimension "V" must be at least 3'3"/1.0 m minimum and no more than 36'/11.0 m maximum.

**Figure 22.** Vertical Terminations with NO elbows

# VENTING

## VERTICAL VENT TERMINATIONS WITH 90° ELBOWS



Distance "H" = 0"/0.0 m minimum to 9'10"/3.0 m maximum

Distance "V1" = 19"/500 mm minimum to 33'10"/10.0 m maximum

Distance "V2" = 19"/500 mm minimum to 33'10"/10.0 m maximum

Distance "V" (V1+V2) = 3'3"/1.0 m minimum to 36'/11.0 m maximum

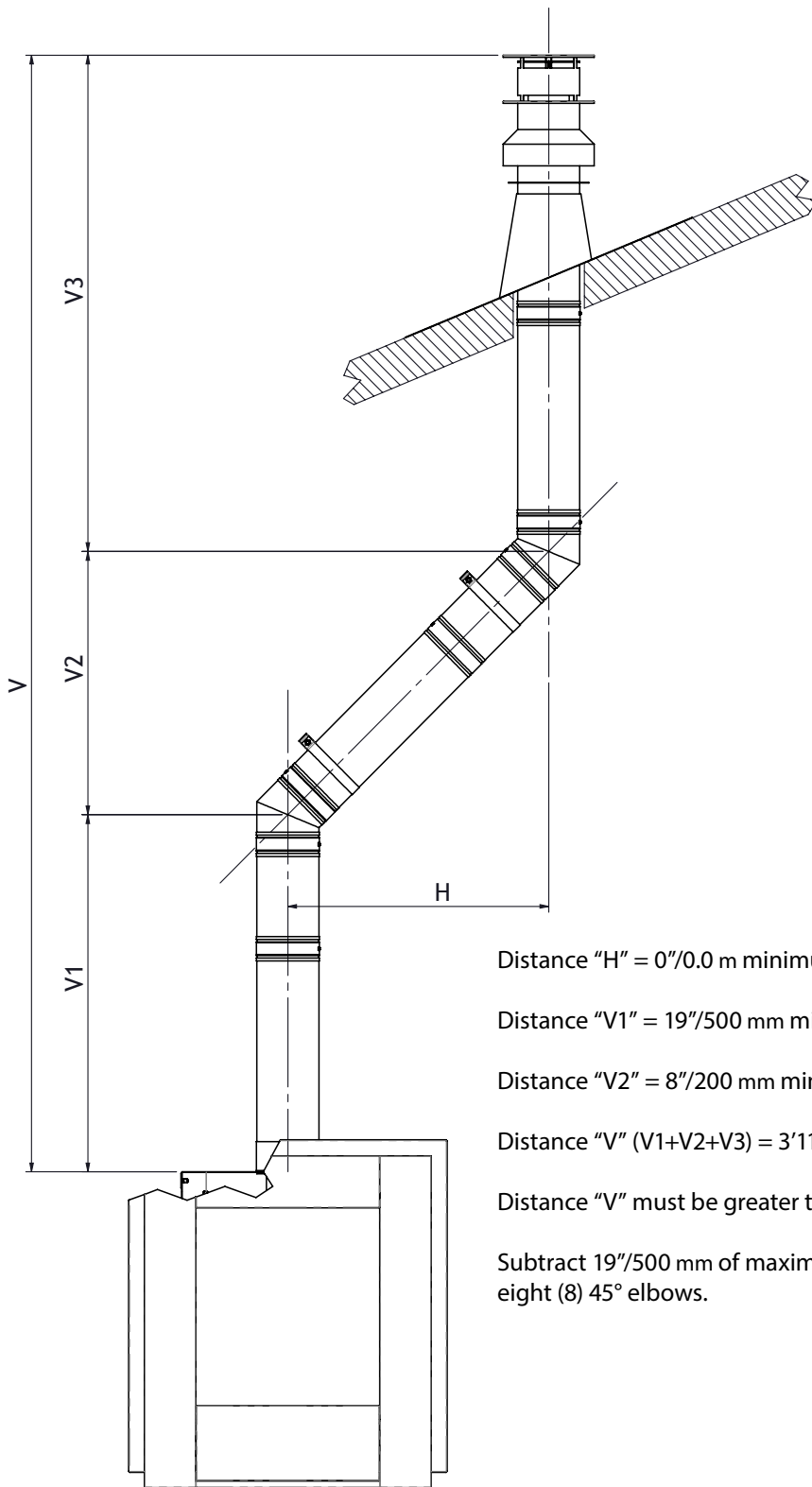
Distance "V" must be greater than twice the distance of "H"

Subtract 3'3"/1.0 m of maximum height for every 90° elbow up to a maximum of four (4) 90° elbows.

**Figure 23.** Vertical Terminations with 90° elbows

# VENTING

## VERTICAL VENT TERMINATIONS WITH 45° ELBOWS



Distance "H" = 0"/0.0 m minimum to 9'10"/3.0 m maximum

Distance "V1" = 19"/500 mm minimum to 33'10"/10.0 m maximum

Distance "V2" = 8"/200 mm minimum to 33'10"/10.0 m maximum

Distance "V" (V1+V2+V3) = 3'11"/1.2 m minimum to 36'/11.0 m maximum

Distance "V" must be greater than twice the distance of "H"

Subtract 19"/500 mm of maximum height for every 45° elbow up to a maximum of eight (8) 45° elbows.

**Figure 24.** Vertical Terminations with 45° elbows

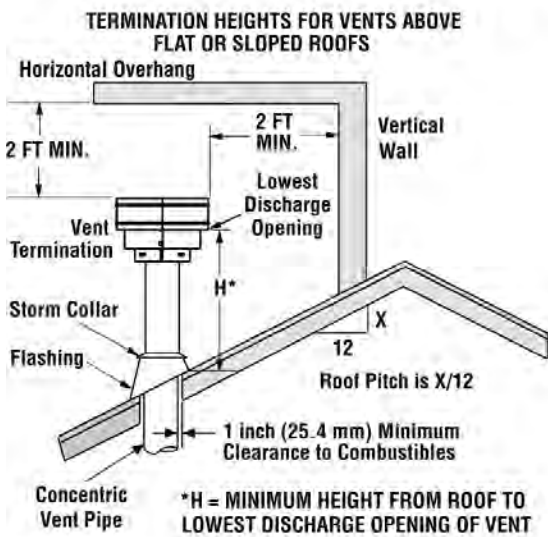
# VENTING

## VERTICAL VENT TERMINATION CLEARANCES AND REQUIREMENTS

### Important Note for Roof Terminations

These instructions should be used as a guideline and do not supersede local codes in any way. Install venting according to local codes, these instructions, the current National Fuel Gas Code (ANSI Z223.1 in the USA) or the current standard of CAN/CSA-B149.1 in Canada.

### Vertical Vent Termination Clearances



The vent / air intake termination clearances above the high side of an angled roof is as shown in the following chart:

Termination Heights for Vents Above Flat or Sloped Roofs Refer to NFPA 54/ANSI Z223.1		
Roof Pitch	H (ft.)	H (m)
Flat to 6/12	1.0	0.3
6/12 to 7/12	1.25	0.38
7/12 to 8/12	1.5	0.46
8/12 to 9/12	2.0	0.61
9/12 to 10/12	2.5	0.76
10/12 to 11/12	3.25	0.99
11/12 to 12/12	4.0	1.22
12/12 to 14/12	5.0	1.52
14/12 to 16/12	6.0	1.83
16/12 to 18/12	7.0	2.13
18/12 to 20/12	7.5	2.29
20/12 to 21/12	8.0	2.44

Chart 1. Termination Heights

A second termination may be no closer than 12"/305 mm. See Figure 19.

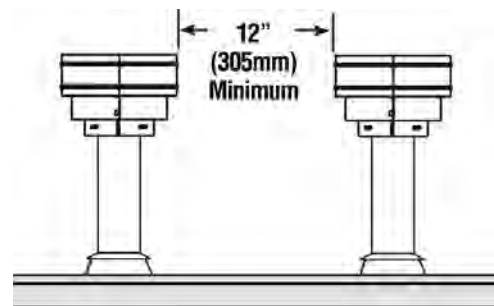


Figure 25. Multiple Termination Clearance

# VENTING

## INSTALLING A RESTRICTOR

No venting restrictor is required for either the Modore 240 or Tenore 240.

	When Using a Horizontal (Wall) Termination	When Using a Vertical (Roof) Termination
When vertical section is up to 39½"/1 m	no restrictor required	no restrictor required
When vertical section is 39½"/1 m to 9'10"/3 m	no restrictor required	no restrictor required
When rise is up to 6'6"/2 m	no restrictor required	no restrictor required
When rise is above 6'6"/2 m	no restrictor required	no restrictor required

*Table 6. Restrictors by Vent Configuration*



# ENCLOSING the FIREPLACE

## WARMTH AND BEAUTY - HOW IT WORKS

The Element4 fireplaces are called direct vent fireplaces and, as such, the intake and exhaust are both handled through the vent pipe. The fireplace also provides convection air to your room. Figure 1 (below) shows one of the unique features of the Element4 fireplaces - its use of convection air flow.

Other fireplaces have louvered metal boxes around them to keep temperatures under control. The Element4 fireplaces use your enclosing walls, or chase, to guide the convection air. This design, therefore, requires the use of non-combustible wall materials and gives you beauty for your effort.

When the air within the chase is warmed by the fireplace it rises and exits through the Convection Air Outlet. This convection air is replaced by room air which enters the chase through the Room Air Inlet. As the exiting convection air cools it falls to the floor where it's drawn into the Inlet and the cycle repeats.

The fireplace itself provides the room air inlet as part of its design; you provide the convection air outlet as part of your design.

See the **ENCLOSING the FIREPLACE** section of this manual for more information.

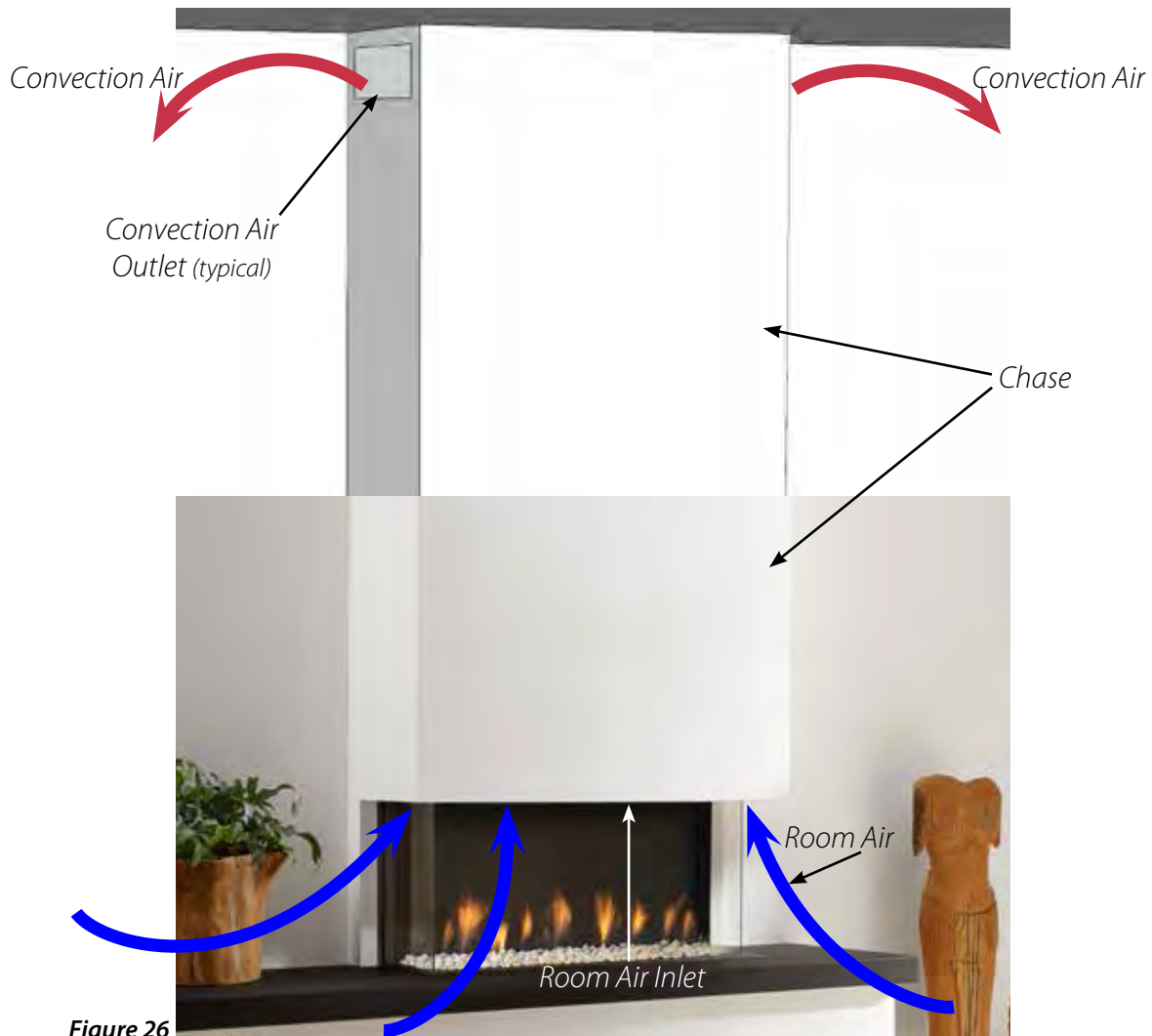


Figure 26

# ENCLOSING the FIREPLACE

## THE FRAMING

A safe installation of your Element4 fireplace requires that four things be clearly understood.

1. Most important, these fireplaces are NOT zero-clearance fireplaces. Unlike most others, there is not a metal box around the Element4 fireplaces. With no metal box there are no louvers to distract your view of the fire. We do, however, want the cooling advantage of a metal box.
2. This means that your fireplace enclosure must be made to *act* the way a metal fireplace box acts - letting room air in below and warm air out above. The non-combustible framing cannot interfere with the air flow. The inlets for the room air are part of the fireplace and cannot be changed or adjusted. The outlet is part of your enclosure design, is provided by you and **MUST** be included. *Note: The Convection Air Outlet must be installed in the same room as the fireplace or a room which ALWAYS flows air into the room in which the fireplace is installed. The flow of convection air must NOT be blocked.*
3. Since these are not zero-clearance fireplaces, the clearances and dimensions listed in the **CLEARANCES** section **MUST** be maintained. Only the non-combustible wall board, the mounting brackets and the venting may touch the fireplace. As previously stated, non-combustible framing must be used and may be no closer than 2"/50 mm.
4. The controls are not mounted on the fireplace, they are to be mounted to your framing and below the burner. The controls are at the end of a 50"/1270 mm line set and are to be mounted to the BDLE4 Access Door, included. The controls must be located for ease of physical access (gas line, maintenance, etc.) as well as wireless signal (remote control) access. See the **LOCATING AND MOUNTING THE CONTROLS** section.

The combination of multiple glass sides and no zero-clearance box makes for a non-typical framing project. As seen in Figures 27-29, it is easy to build the 'rough opening', set the fireplace then attach the wall. For projects with tight clearances, however, it may be easier to set the fireplace first then frame around it and attach the wall.

In any case, the framing around these fireplaces must NOT be supported by the fireplace and the wall material may NOT be attached to the fireplace. The framing must be attached to another structure which can bear the entire weight of the enclosing walls and any attachments to the walls such as TVs, shelves, artwork, etc. The wall material must be attached **ONLY** to the framing.

## COLD CLIMATE INSULATION

For cold climate installations, it is especially important to insulate outside the chase cavity, between studs and under the floor on which appliance rests, if floor is above ground level. Gas line holes and other openings should be filled with approved firestop.

If the fireplace is being installed on a cement slab in cold climates, a sheet of plywood or a raised platform can be placed underneath to prevent cold transferring to the fireplace and into the room. It also helps to tape for maximum air tightness and to caulk firestops.

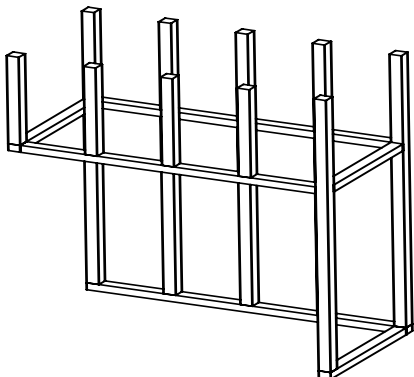


Figure 27

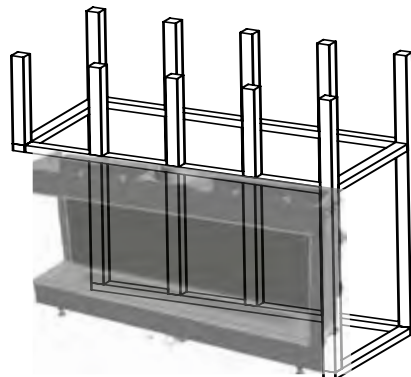


Figure 28

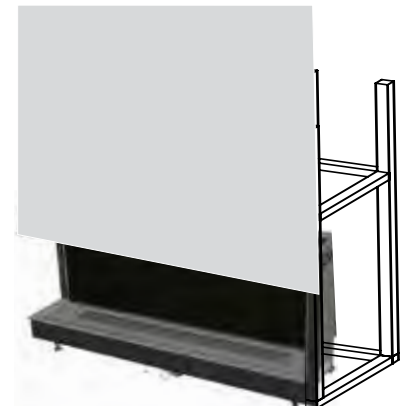


Figure 29

# ENCLOSING the FIREPLACE

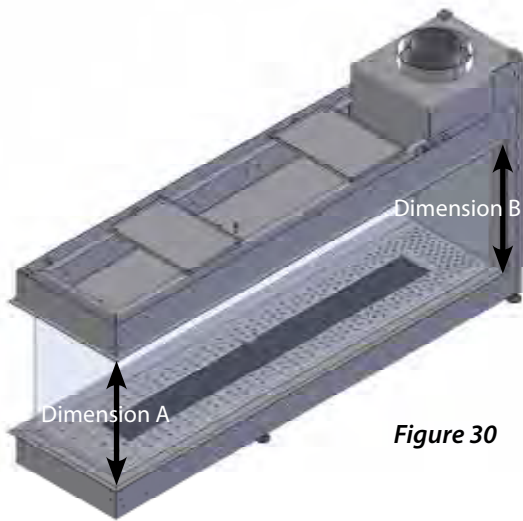


Figure 30



**DO NOT ALLOW THE FIREPLACE TO BEAR ANY WEIGHT**



Dimension A and Dimension B, shown in Figure 32, must be equal throughout the installation, no matter the model.

The wall framing must be at least 2"/50 mm (NON-combustible framing ONLY) from the fireplace and the entire weight of the non-combustible wallboard (see page 6) is carried by the framing. Since most Element4 fireplaces have two or three sides of glass, the upper wall framing is usually hung from the ceiling or often cantilevered. See Figure 31.

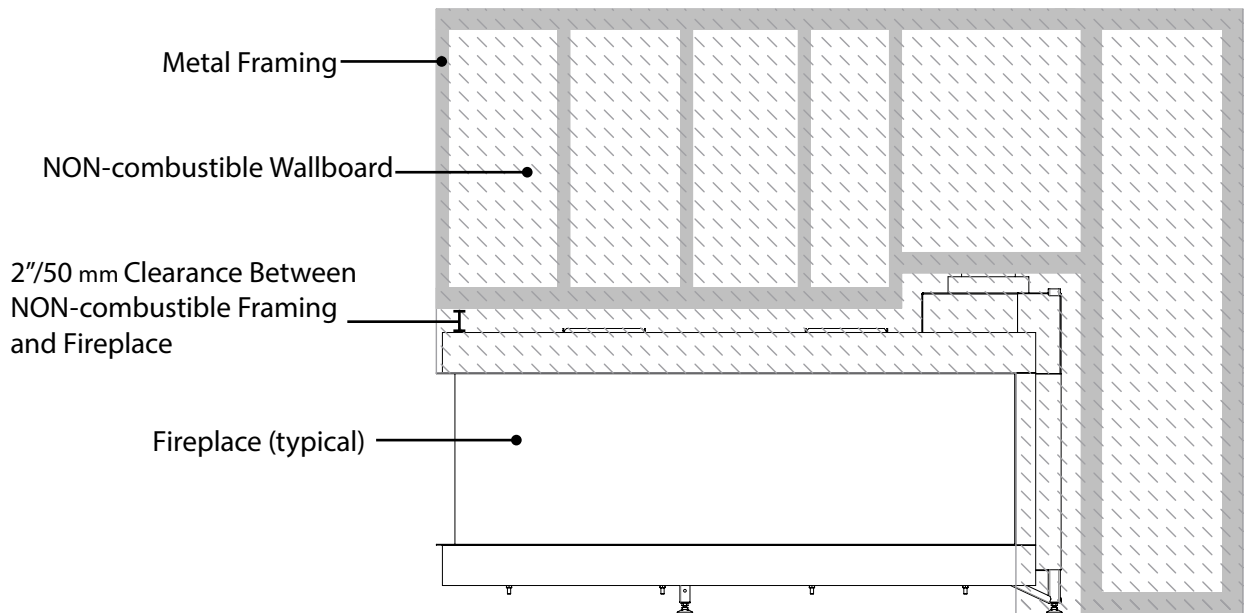


Figure 31

Convection Air Outlet Area by Model		
Model	Square Inches	Square Centimeters
Modore 240	102	685
Trisore 140	204	1316

Table 7.

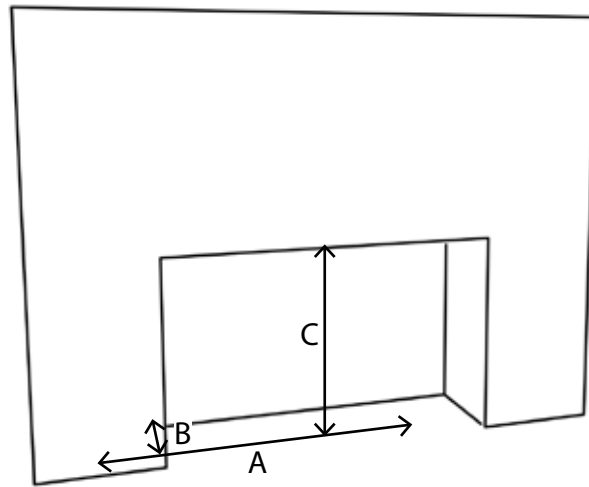
A convection air outlet is always required and the area of the convection air outlet varies by fireplace model. Table 7 shows the minimum total area required for the various models. This table assumes an enclosed chase with a top or 'ceiling' and with the convection air outlet(s) on the wall(s) of the chase.

However, if the chase takes the form of a 'half-wall' and there is no top on the half-wall then convection air will escape out of the 'top' of the half-wall. In this case, outlets on the walls are not required.

# ENCLOSING the FIREPLACE

Rough Opening Dimensions for <b>NON-COMBUSTIBLE</b> Framing				
Model	Figure	A	B	C
<b>Modore 240</b>	34	109½"/2780 mm	17"/434 mm	41¼"/1048 mm
<b>Tenore 240</b>	34	109½"/2780 mm	15⅞"/384 mm	41¼"/1048 mm

*Table 8*



*Figure 32*

# FIRE MEDIA

## INSTALLING THE HEARTH PANELS (ALL MODELS)

The fireplace has an eight piece hearth panel set which is assembled in the order shown below. Note that panel number 1 is fixed in place, all other panels are packaged separately.



Figure 33 Center



Figure 34 Left Side



Figure 35 Right Side



# FIRE MEDIA

## LOG ARRANGEMENTS

Ensure that the hearth panel is sitting firmly in the base of the fire box with the long slot in the center of the panel aligning with the top of the burner. The pilot flame must be visible through the panel and the cut-out in the pilot shield. Place the six coals and two cones as shown in Figures 36a-f. Ensure that the area around the pilot and second thermocouple remains clear.



*Figure 36*



*Figure 37*

# FIRE MEDIA



*Figure 38*



*Figure 39*

# FIRE MEDIA



*Figure 40*



*Figure 41*



# FIRE MEDIA

## CARRARA PEBBLES ARRANGEMENTS

Ensure that the grate is sitting firmly in the base of the fire box with the long slot in the center of the grate aligning with the center slots on the burner tube. The pilot flame must be visible through the grate and the cut-out in the pilot shield.

Scatter evenly the contents of the bags of pebbles over the top of the grate and burner.

Ensure that none of the pebbles enters the pilot enclosure.

The arrangement of the pebbles is now complete. However, it is important to check that the pilot flame is still visible.

Figure 42 shows the arrangement for all models.

Figure 43 shows how the area around the pilot burner must be kept clear of fire media.



*Figure 42*

Figure 44 shows the 2nd thermocouple area kept clear of media on all models.



*Figure 43*



*Figure 44*

# OPERATING the FIREPLACE

## BEFORE THE FIRST FIRE

1. Make sure all construction materials have been removed from inside and around the fireplace.
2. Confirm the proper placement of the burner media.
3. Confirm that the controls are properly connected.
4. Check the gas supply for leaks.
5. Close and properly clamp the glass panels.
6. Check that the venting is unobstructed and in proper working condition.

## PAIRING THE REMOTE AND RECEIVER (Resetting the System)

The remote control must be paired to the receiver prior to first use. This is done as follows:

1. Press and hold the receiver reset button (Figure 45) until you hear the second of two beeps. After the second beep release the reset button and,
2. within twenty seconds, press and hold the **↓** button on the remote until you hear the second of two beeps. Release the **↓** button.



Figure 45. Receiver

## USING THE REMOTE CONTROL ELECTRONIC IGNITION SYSTEM

Note: The system shuts off the appliance completely if there is no change in the flame height for 5 days.

### Setting °C/24 Hour or °F/12 Hour Clock.

Press **OFF** and **↓** to toggle between °F/12 hr and °C/24 hr clock.

### Setting the time.

Simultaneously press the **↓** and **↑** buttons, the display now flashes.

Press **↑** to set the hour and **↓** to set the minute.

Press **OFF** to return to manual mode.

### Igniting the Appliance.

On the remote control, simultaneously press and hold the **OFF** and **↑** buttons.

An acoustic signal indicates that the start sequence has begun.

The electronic system then checks that the main gas is flowing and ignites the main burner; this may take up to 20 seconds.

NOTE: During start-up, the **MANUAL** knob on the gas valve cannot be in the **MAN** position. See Figure 47.

### Changing the Mode of Operation.

Briefly pressing the **SET** button changes the mode of operation in the following order:

**Man** - **Temp** - **Timer** - back to **Man**

### Temp - Manual Flame Height Adjustment.

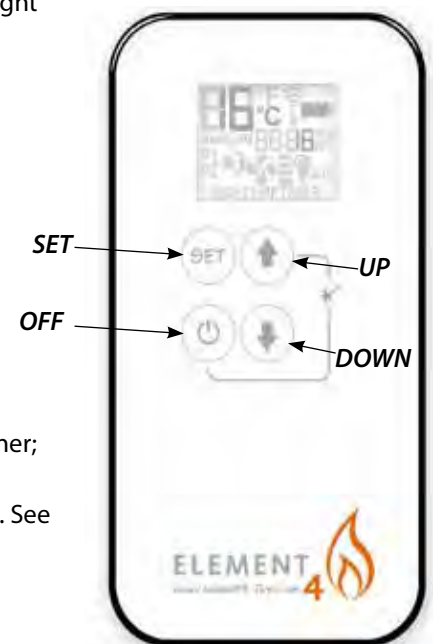


Figure 46. Remote Control

# OPERATING the FIREPLACE

You are now able to use the remote control. To increase the flame, the **↑** button should be depressed. Pressing the **↓** button on the handset will reduce the flame. The main flame may be lowered all the way down until it is off, leaving only the pilot ignited. Simultaneously press the **SET** button and the **↓** button to turn the two end burners off. Simultaneously press the **SET** button and the **↑** button to turn the two end burners on.

## Fully Extinguishing the Appliance

From any heat setting, press the **OFF** button for a few seconds. This will cause the burner to fully extinguish. The system has a safety interlock which will not allow the ignition until the interlock rests. This may take a few minutes. The appliance should be shut off completely using the **OFF** button on the handset and not left on pilot only, except for temporary use. This resets the system and all safety features.

## ☼Temp - Daytime Temperature mode.

The appliance must be in standby mode; pilot ignited. The room temperature is measured and compared to the set temperature. The flame height is then automatically adjusted to reach the daytime set temperature.

## ☽Temp - Nighttime setback Temperature mode.

The appliance must be in standby mode; pilot ignited. The room temperature is measured and compared to the nighttime setback temperature. The flame height is then automatically adjusted to achieve the nighttime setback temperature.

## Timer mode.

The appliance must be in standby mode; pilot ignited. The Timer setting allows you to set 2 burner ☼Temp times and 2 burner ☽Temp times every 24 hrs.

For ☽Temp to operate as a thermostat, TEMP must be set at 4°C or higher.

If the ☽Temp setting is decreased to --, the motor will turn the valve to the standby position in the moon times and await the next burner ☼Temp cycle.

## Setting the Temperature.

Select either the ☼Temp MODE or the ☽Temp MODE by briefly pressing the **SET** button.

Hold the **SET** button until the TEMP display flashes.

Set the desired temperature with **↓** or **↑**.

Press **OFF** to complete the program.

## Setting the Timer.

Select Timer mode by briefly pressing the **SET** button.

Press and hold the **SET** button until the P1☼ is displayed, and the time flashes. Set the hour by pressing **↑** and set the minutes by pressing **↓**.

Briefly press **SET** button for the next burner cycle time.

Once all 4 times are set, press **OFF** to complete the programming.



Figure 47. Gas Valve

# OPERATING the FIREPLACE

## Automatic Turndown.

1. In Manual/Temperature/Timer modes, the valve will turn to pilot flame if there is no change in flame height for a six hour period. In Temperature or Timer mode, if the ambient room temperature changes, the flame height will adjust automatically to maintain set temperature and the fire will continue to function normally. The valve will turn to pilot flame if the set temperature and the ambient room temperature remain the same over a six hour period.

2. The valve turns to pilot flame if the temperature in the receiver is higher than 140°F/60°C. The main burner comes back on only when the temperature is below 140°F/60°C.

## Automatic Shut Off.

1. With low battery power in the receiver, the system shuts off the fire completely. This does not happen if the power supply is interrupted.

2. The system shuts off the fire completely if there is no change in flame height for 5 days.

3. The system shuts off the fire if the main burner does not completely ignite approximately 20 seconds after ignition or after pushing the **▲** button.

## THE FIRST FIRE

Before lighting the fireplace for the first time, ensure that the fireplace is clean and free of any foreign objects, dust or construction debris. Make certain that all of the electric, gas and venting connections are proper and secure.

The first time you light your fireplace an odor may be given off by the hot metal. This is normal and is a result of the 'burn off' of the lubricants and sealants used when manufacturing the fireplace. We recommend that you open the nearby windows for extra ventilation and operate the fireplace for at least four hours.

Upon lighting the fireplace when the glass is cold, some condensation may appear on the glass. This is normal and the condensation will disappear as the glass warms.

During this first fire, examine the flame for appearance and quality. Examine the burner media for sooting. The flames should look like those shown in Figure 48.

After this burn-off period, turn off the fireplace and let it cool completely to room temperature and clean both sides of the glass and the interior panels as described in the **MAINTENANCE** section.

Since it is a metal fireplace, the heat-up and cool-down cycles may produce some noises caused by the expansion and contraction of these metals. The premium materials and build quality of your fireplace will keep these sounds to a minimum.



Figure 48

# GLASS CLEANING

## REMOVING AND CLEANING THE GLASS

### OVERVIEW

The glass panel(s) are held in place by two gasketed clamps (one on either side with two bolts each) and a rope gasket at the lower edge of the glass. These instructions require two technicians and will show you how to remove and install the glass panel(s).

Please read these instructions completely before proceeding.

### TOOLS REQUIRED

- No. 2 Phillips screwdriver (not included)
- 2 vacuum clamps (included)

### REMOVING THE GLASS

#### Step 1.

Remove all of the trim pieces (magnetically attached) from the fireplace. See Figure 49. The Tenore has two glass panels, therefore, twice the number of trim pieces. There is no top trim on either fireplace. The trim pieces are held firmly in place with magnets and will simply lift out. The bottom (horizontal) trim pieces are at the lower edge of the glass panels and the side (vertical pieces) are where the glass meets the wall.

#### Step 2.

The glass panel is held in place by a gasketed glass clamp on the left and right ends and a rope gasket along the bottom edge. Remove the retaining bolt(s) holding the glass clamps and then remove the clamps. See Figure 50. Gently pull the rope gasket from its channel.

#### Step 3.

Securely attach a vacuum glass clamp to the glass approximately 24"/600 mm from either end and lift the glass up into the clearance notch.

With the glass panel raised into the upper rail, swing the lower edge of the glass panel out towards the room and gently lower the glass towards the floor until it clears the fireplace. See Figure 51.

#### Step 4.

Repeat Steps 2 and 3 for the other glass panel, if present.

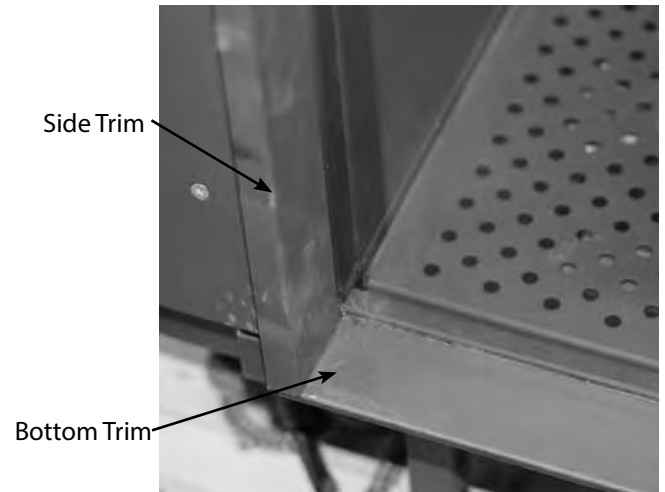


Figure 49



Figure 50

# GLASS CLEANING

## CLEANING THE GLASS

The glass should be cleaned as necessary with a fireplace glass cleaner. We recommend Stove Bright® Gas Appliance Glass Cleaner by Forrest Paint Co. It is available through your retailer. Follow the instructions for use and do not clean the glass when it is hot! If the glass becomes coated with deposits which cannot be removed it must be replaced.

## INSTALLING THE GLASS

The glass panel(s) should be installed in reverse order of their removal.

### Step 1.

Securely attach the two vacuum glass clamps, each approximately 24"/600 mm from either end. Lift the glass panel up into the upper rail and swing the lower edge of the glass panel against the firebox gasket. See Figure 51. Set the glass clamps into place and hold them loosely into place with a retaining bolt. DO NOT tighten the retaining bolts yet.

### Step 2.

Ensure that the glass is flat against the firebox gasket and centered on the firebox.

### Step 3.

Center the rope gasket on top of the gasket channel (in front of the lower edge of the glass.) While holding the center in place, gently stretch the gasket while laying it into the gasket channel, left and right. Press the gasket down into the length of the gasket channel. See Figure 52.

### Step 4.

Hand tighten the bolts onto the glass clamps. Tighten the bolts ¼ turn further.

### Step 5.

While ensuring that the glass panels are tight and square to each other, tighten the retaining bolt(s) on each clamp NO MORE THAN ¼ TURN.

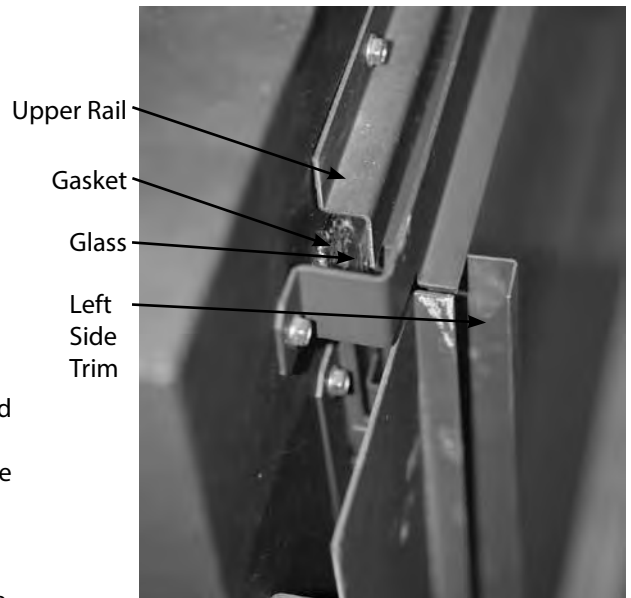


Figure 51

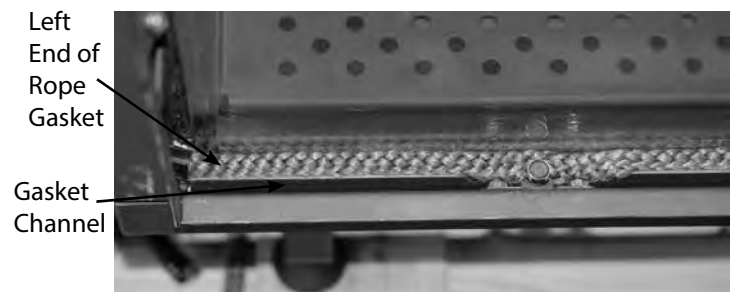
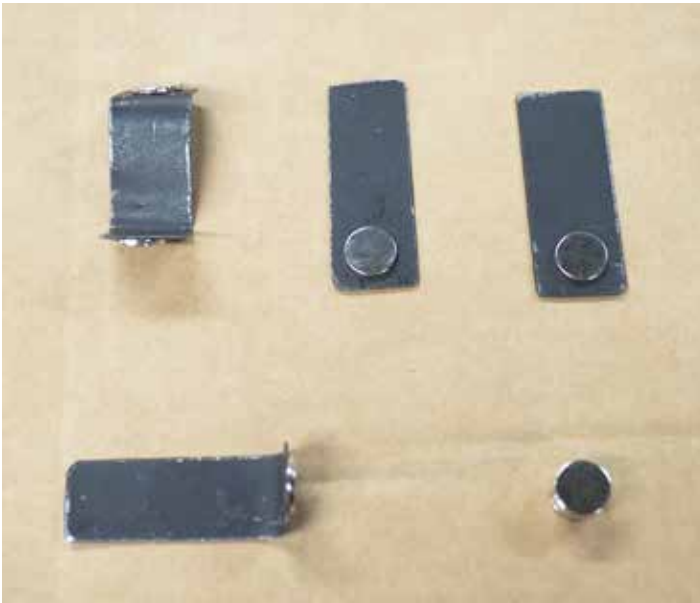


Figure 52

## INSTALLING the SCREENS



- Parts included:
- (2) Flat metal tabs
  - (1) "L" Shaped metal tab
  - (1) "S" Shaped metal tab
  - (12) Magnets

*Figure 55*



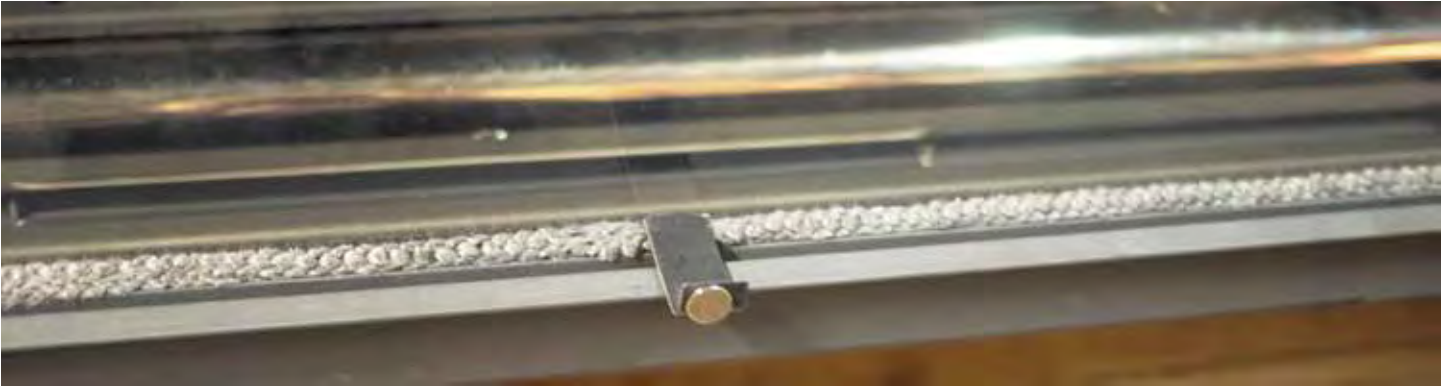
*Figure 53* Place a single magnet on the bottom return flange 12" from the lower left corner, lower right corner, and the center.



*Figure 54* Place flat metal tab on magnet and push against glass on both left and right sides (not center).

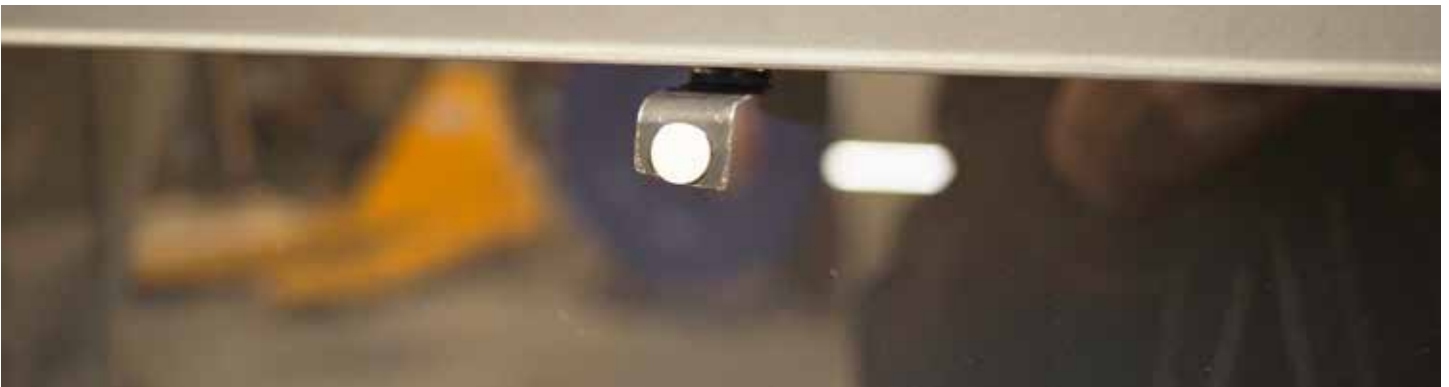


## INSTALLING the SCREENS

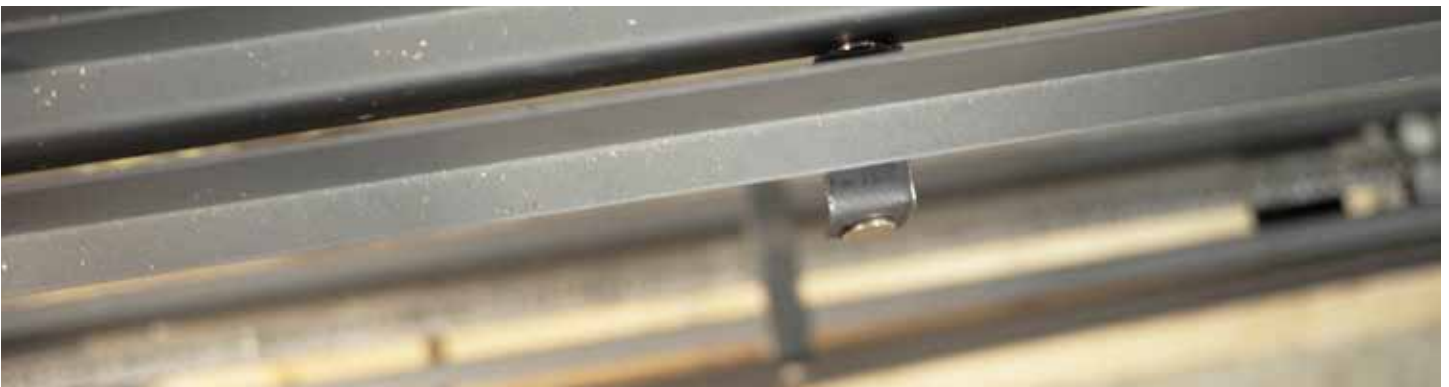


**Figure 58** Place "L" shaped metal tab on center magnet with the short end facing up and out. Place magnet on short end face.

Using the "S" shaped metal tab, place a magnet on both face ends. Position metal tab at the top center of the fireplace. Slide tab up to the top of the trim so that one end of the tab sticks to the fireplace cabinet, not the outer frame (see below).



**Figure 56** *Straight View*  
(Straight view of top, center, tab.)



**Figure 57** *Overhead View*  
(Overhead view of top, center, tab.)



# INSTALLING the SCREENS

When the bottom trim put into place the 3 metal tabs will be exposed (see below).



*Figure 59*



*Figure 60*

# INSTALLING the SCREENS

Place 3 magnets on both left and right trims (top, center, bottom) and attach trims to fireplace.



**Figure 61** Without side trim



**Figure 62** With side trim plus magnets

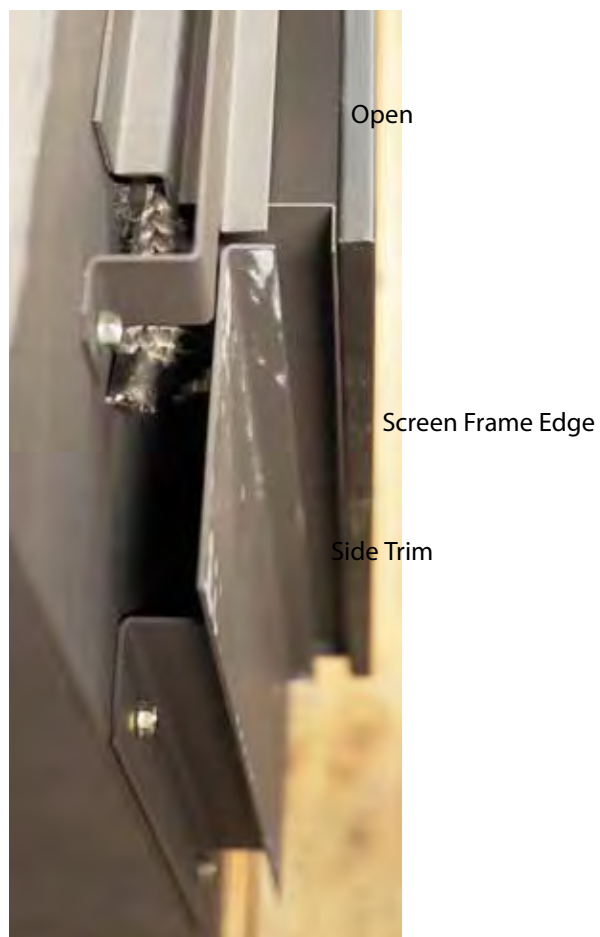


**Figure 63** Rest the bottom of the screen on the 3 tabs that are under the trim. Push the screen into position so that the exposed magnets come in contact with the screen frame.

# INSTALLING the SCREENS



**Figure 64** Screen in Position



**Figure 65** Top View with Screen Attached

# MAINTENANCE

## WARNING

Installation and maintenance must be performed by an authorized qualified installer, service agency or gas supplier.

TURN OFF THE GAS before servicing the appliance. It is recommended that a qualified service technician perform an appliance check-up/service once a year.

Any safety screen or guard removed for servicing MUST BE REPLACED before operating this appliance.

DO NOT USE this appliance if any part has been under water. Immediately, call a qualified service technician to inspect the unit and to replace any part of the control system and any gas control that has been under water.

Any alteration to the product that causes soot or carbon to form and results in damage is not the responsibility of the manufacturer.

Inspect the external vent cap on a regular basis to make sure that no debris, plants, trees, shrubs are interfering with the air flow.

## BURNER MAINTENANCE

The flames from the burner should be visually checked. The flame should have a blue base and yellow tops and be candle-like in appearance.

## PILOT MAINTENANCE

The pilot flame must be visually checked. The pilot flame must always be present when the appliance is in operation and should appear as in Figure 67.

The pilot burner has two distinct flames, one engulfing the thermocouple, the other reaches across to the main burner.

The area around the injector should be inspected and any lint or foreign material must be removed with a brush or vacuum.

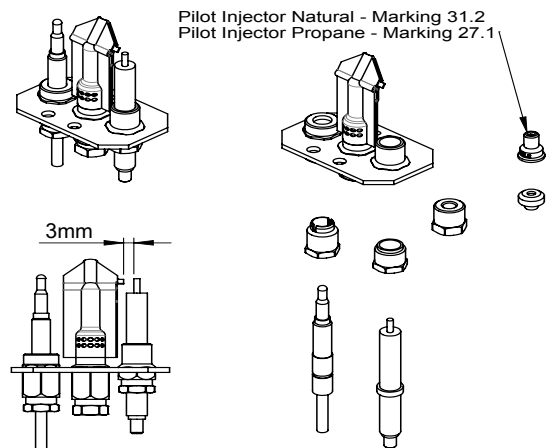


Figure 66. Pilot Burner Detail

# MAINTENANCE

## THERMOCOUPLE MAINTENANCE

The Element4 fireplaces have two thermocouples; one next to the pilot flame and one opposite the pilot burner on the other side of the main burner. The completeness and operation of both must be checked. A qualified installer must confirm that the thermocouple is in place and not cracked or damaged.

Figure 67 shows a typical pilot flame engulfing the first thermocouple.

## VENT MAINTENANCE

The following venting system inspection by a qualified service technician is recommended every six months:

1. Inspect for excessive condensation, e.g. water droplets forming in the inner lining and subsequently dripping out of the joints. This can cause corrosion in the system.
2. Check for corrosion in areas exposed to the elements. Where rust spots or holes have appeared, these must be immediately replaced.
3. Ensure that there is no foreign material in the vents. Survey by removing the cap and shining a light down the vent.
4. Check all joints and pipes to make sure that nothing has been disturbed or loosened.

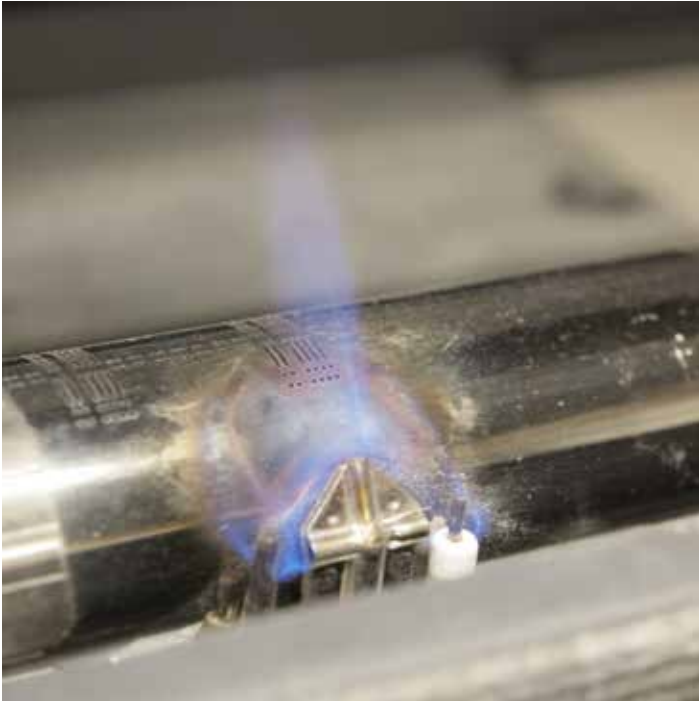


Figure 67

## REPLACEMENT PARTS

The orifice for the main burners is shown in Figure 45. All **NG** orifices are marked 1200, all **LP** orifices are marked 220.

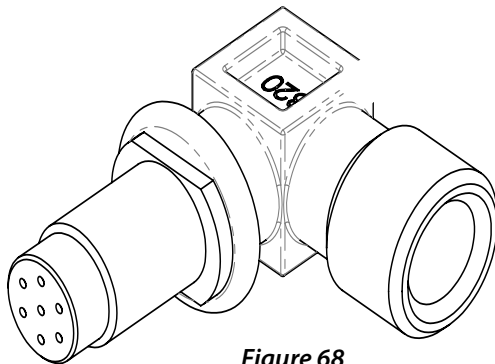


Figure 68

E4-GS-1T-01  
E4-GS-2T95-02  
E4-GS-CM-01  
E4-GS-PA-01  
E4-GS-RC-01

Primary Thermocouple  
2nd Thermocouple  
Receiver  
Pilot Assembly  
Remote Control

# WARRANTY

## European Home Warranty Element4 Gas Fireplace

European Home warrants these gas fireplaces against defects in materials and workmanship for a period of ONE (1) YEAR from the date of original retail purchase. Glass is expressly NOT covered by this warranty.

If a defect exists, European Home will, at its option, either (1) repair the product at no charge, using new or refurbished replacement parts or (2) exchange the product with one which is new or which has been manufactured from new or serviceable used parts and is at least functionally equivalent to the original product. A replacement product/part assumes the remaining warranty of the original product or ninety (90) days from the date of replacement or repair, whichever provides longer coverage for you. When a product or part is exchanged, any replacement item becomes your property and the replaced item becomes the property of European Home.

Nothing in the above shall be deemed to imply that this warranty shall apply to work which has been abused or neglected or shows evidence of changes or modifications by others with or without permit, damages caused by the acts of God, building settlement or moving, fire or vandalism. In addition, installation of this product that varies from the requirements stated in the instruction manual will void the warranty.

European Home is a division of Europa Ja, Inc.

### PRODUCT INSTALLATION RECORD

Installer: Please complete this form.

Customer: Please retain this information.

Purchased From	
Date of Purchase	
Installed By	
Date of Installation	
Fireplace Serial Number	
Fuel Type	

VENTING SYSTEM INSTALLATION INSTRUCTIONS



Venting System For Direct Vent  
Gas Stoves and Fireplaces

DIRECT VENT PRO

**DuraVent**  
Member of & M&G Group

# APPENDIX ONE

**A MAJOR CAUSE OF VENT RELATED FIRES IS FAILURE TO MAINTAIN REQUIRED CLEARANCES (AIR SPACES) TO COMBUSTIBLE MATERIALS. IT IS OF THE UTMOST IMPORTANCE THAT DOUBLE WALL DIRECTVENT PRO BE INSTALLED ONLY IN ACCORDANCE WITH THESE INSTRUCTIONS.**

**IMPORTANT:**

**Read through all of these instructions before beginning your installation. Failure to install this product as described in these instructions will void the manufacturer's warranty, may create a fire or other safety hazard, and may affect your homeowner's insurance and safety listing of your appliance.**

**Keep these instructions for future reference.**

**Dear Customer, Installer, or End User:**

We welcome any comments regarding matters pertaining to our DuraVent products.

We welcome any ideas, input or complaints and I'll make sure that someone responds directly back to you.

Send your emails to:  
[president@duravent.com](mailto:president@duravent.com)

If you are searching for tech support or product information, please phone us at 800-835-4429.

Or email us at:  
[techsupport@duravent.com](mailto:techsupport@duravent.com)



# APPENDIX ONE

## VENTING SYSTEM FOR DIRECT VENT GAS STOVES AND FIREPLACES

*For the most up-to-date installation instructions, see [www.duravent.com](http://www.duravent.com)*

### CONTENTS

Application   Warning   Safety & Installation Precautions	51
Options   Planning Your Installation	52
Horizontal Installation	53
Snorkels	57
Installing Vinyl Siding Standoff	59
Installing Counter Flashing	60
Vertical Installation	61
Cathedral Ceiling Installation	65
General Maintenance / Labels	67
Supplemental Canadian Instructions	68
M&G DuraVent Warranty	70

# DIRECT VENT PRO

**DuraVent**  
Member of  M&G Group

# APPENDIX ONE

## APPLICATION

These instructions apply to the M&G DuraVent DirectVent Pro 4"x6-5/8" and 5"x8" systems. This venting system, in combination with the gas appliance, has been tested and listed as a decorative gas appliance system or as a direct vent heater system by a major testing agency such as UL, AGA, CGA, OMNI, or Warnock Hersey. Check the manufacturer's rating plate and instruction manual to confirm that the M&G DuraVent Direct Vent is approved for use on the brand name appliance you have selected.

## IMPORTANT

Read all instructions carefully before starting the installation. Failure to follow these instructions may create a fire or other safety hazard and will void the warranty. **Check with the appliance manufacturer's installation instructions for specific venting and clearance to combustible requirements, which may vary from one appliance to another.** Be sure to comply with minimum or maximum distances of vertical or horizontal runs as prescribed in the appliance manufacturer's installation instructions.

## WARNING

- Always maintain required clearances (air spaces) to nearby combustibles to prevent a fire hazard. Do not fill air spaces with insulation. Be sure to check the appliance manufacturer's installation instructions for minimum clearance requirements between the outer walls of the vent pipe and

nearby combustible surfaces. Be sure to check the vent termination clearance requirements from decks, windows, soffits, gas regulators, air supply inlets, and public walkways, as specified in these installation instructions and local building codes.

- The gas appliance and vent system must be vented directly to the outside of the building, and never be attached to a chimney serving a separate solid fuel or gas-burning appliance. Each direct vent gas appliance must use its own separate vent system. Common vent systems are prohibited.

## SAFETY PRECAUTIONS FOR THE INSTALLER

- Wear gloves and safety glasses for protection.
- Exercise extreme caution when using ladders or on roof tops.
- Be aware of electrical wiring locations in walls and ceilings.

## INSTALLATION PRECAUTIONS

The M&G DuraVent DirectVent Pro is an engineered product that has been designed and tested for use with approved direct vent gas appliances only. The M&G DuraVent warranty will be voided, and serious fire, health, or other safety hazards may result from any of the following actions:

- Installation of any damaged DirectVent Pro component.
- Unauthorized modification of the DirectVent Pro System
- Installation of any non-DirectVent Pro pipe or component part not approved

# APPENDIX ONE

by M&G DuraVent or the appliance manufacturer.

- Installation other than as instructed by M&G DuraVent or the appliance manufacturer.

**Consult your local building codes before beginning the installation.**

## OPTIONS

The M&G DuraVent DirectVent Pro offers a complete line of component parts for both horizontal and vertical installations. Many items are offered in decorative black as well as galvanized finish. The galvanized pipe and fittings may be used for concealed locations such as attics, or spaces where corrosion is a factor, such as above the roofline. Decorative black painted sections are recommended for use on visible interior runs. Snorkel Terminations are available for applications which may require vertical rise on the building exterior.

## PLANNING YOUR INSTALLATION

There are two basic types of DirectVent Pro installations. Check the appliance manufacturer's installation instructions to confirm what types of installations are permitted and check for any venting restrictions such as maximum horizontal run, and minimum or maximum vertical rise. The two types of installations are:

- Horizontal Termination (**Figs. 1 and 2**)
- Vertical Termination (**Fig. 3**)

When planning your installation, it will be necessary to select the

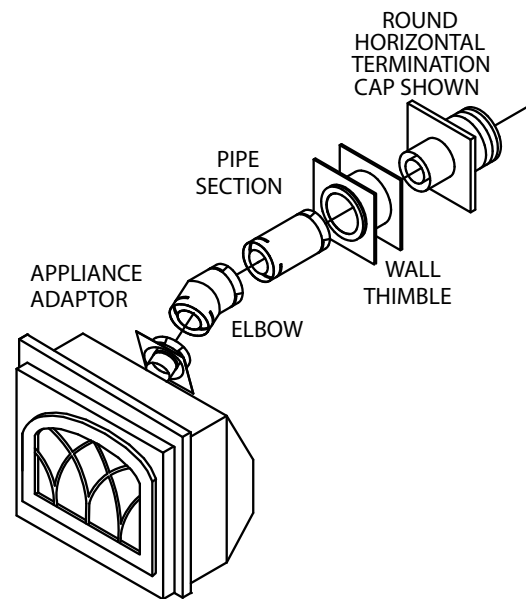


Figure 1

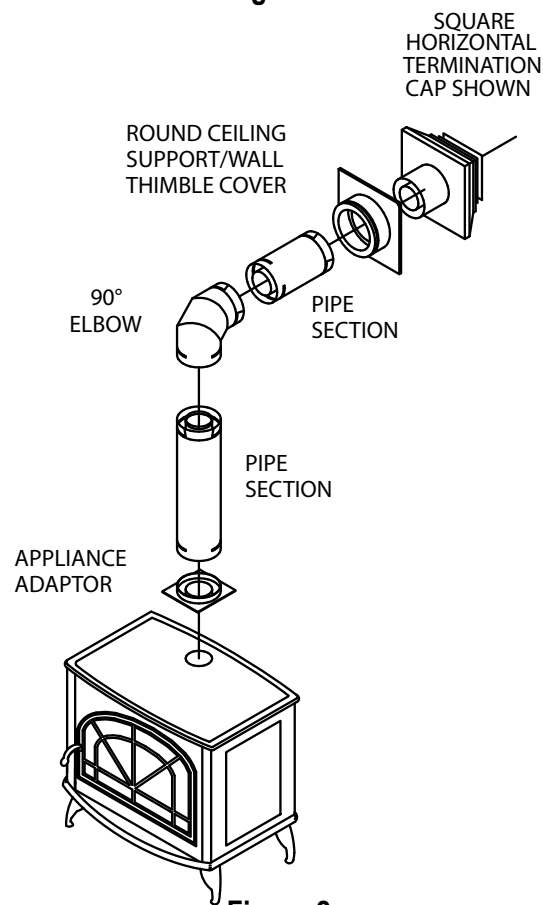


Figure 2

# APPENDIX ONE

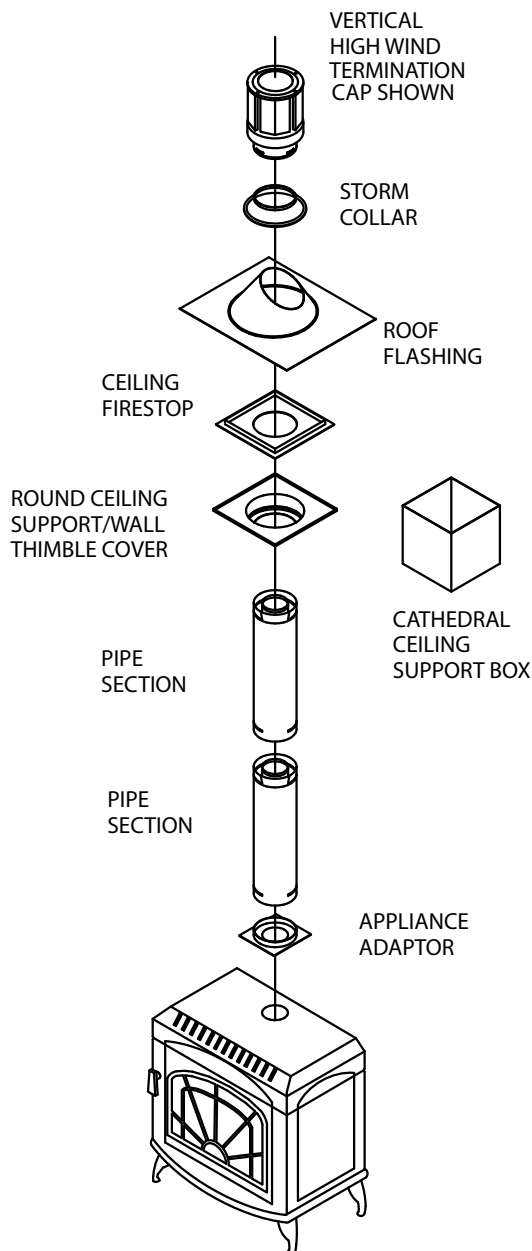


Figure 3

proper length of vent pipe for your particular requirements. For horizontal installations, check the appliance manufacturer's installations instructions to determine the minimum clearance from the rear of the appliance to the wall. It is also

important to note the wall thickness. Select the amount of vertical rise desired or required, for "vertical-to-horizontal" installations (verify that it is within the appliance manufacturer's minimum and maximum limits). To determine the length of vent pipe required for vertical installations, measure the distance from the appliance flue outlet to the ceiling, the ceiling thickness, the vertical rise in an attic or second story, and allow for sufficient vent height above the roofline. For two-story applications, Firestops are required at each floor/ceiling level. If an offset is needed in the attic, additional pipe and elbows will be required.

## HORIZONTAL INSTALLATION

**Step 1.** Set the gas appliance in its desired location. Check to determine if wall studs or roof rafters are in the way once the venting system is attached. If this is the case, you may want to adjust the location of the appliance.

**Step 2.** DirectVent Pro pipe and fittings are designed with special twist-lock connections. To connect the venting system to the appliance flue outlet, a twist-lock Appliance Adaptor is required. With some brands of appliances, the M&G DuraVent Appliance Adaptor will be built into the appliance at the factory. With other brands the adaptor will be supplied by the appliance manufacturer for installation in the field. Assemble the desired combination of Pipe Sections and Elbows to the Appliance Adaptor (**Fig. 4**).

# APPENDIX ONE

## Notes:

(1) Twist-lock procedure: Line up locking lugs on male and female ends of pipe sections. Insert the male end of pipe into the female end until the locking lugs are covered. Twist the female end clockwise an eighth of a turn to lock sections together (**Fig. 5**). Screws are not required to secure the joint, but are acceptable provided they do not penetrate the inner wall of the vent pipe.

(2) Horizontal runs of vent pipe must be supported to prevent any downward sags. Horizontal pipe sections should be supported at least every 4-feet. Wall Straps can be used for this purpose. Alternatively, plumbers tape or other suitable noncombustible material can be used to support the vent pipe.

(3) DirectVent Pro venting requires no sealant, unless specifically required by appliance manufacturer.

**Step 3.** With the Appliance Adaptor and Pipe Section attached to the appliance, slide the appliance into its correct location, and mark the wall for a square hole of the appropriate size. Refer to **Table 1, page 8** for the correct size square opening unless otherwise specified by the appliance manufacturer's clearance requirements. The centerline of the pipe should line up with the center of the square hole (**Fig. 6**). Cut and frame the square hole in the exterior wall where the vent will be terminated. A Wall Thimble or Wall Firestop may be required by the appliance manufacturer as additional thermal protection for the wall. If the

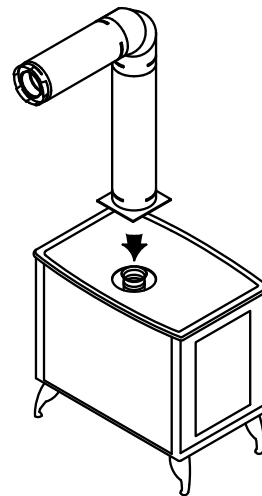


Figure 4

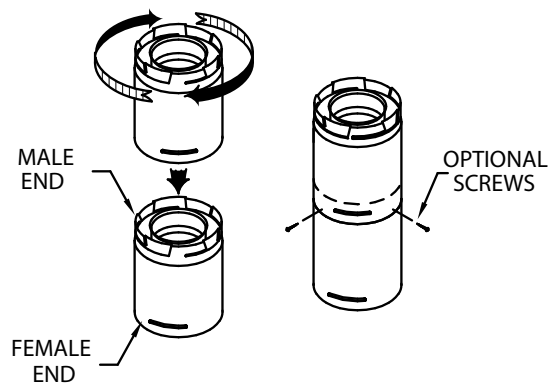


Figure 5

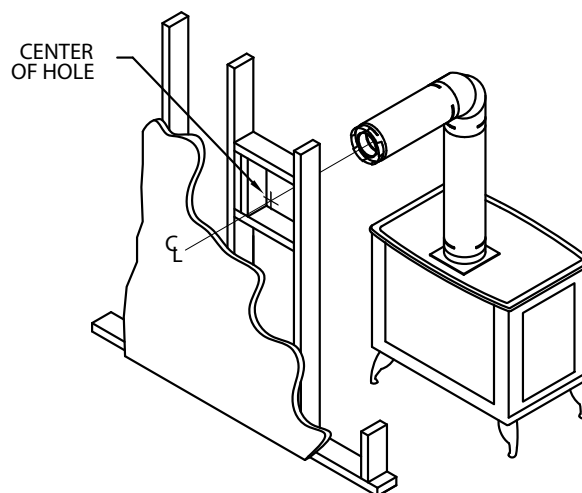


Figure 6

# APPENDIX ONE

TABLE 1

DIRECTVENT PRO FRAMING OR CUTOUT DIMENSIONS

STOCK NUMBER	COMPONENT DESCRIPTION	SIZE
46DVA-WT	Wall Thimble	10"x 10"
46DVA-WTS	Wall Thimble (Small)	9"x 9"
46DVA-WTU	Wall Thimble Universal	9"x 9"
46DVA-CS	Ceiling Support	10-3/4"x 10-3/4"
46DVA-FS	Fire Stop	9"x 9"
46DVA-WFS	Wall Fire Stop	10"x 10"
46DVA-VSS	Vinyl Siding Standoff	17"x 17"
46DVA-CF	Counter Flashing (Assembled)	13-1/2"x 13-1/2"
46DVA-CFK	Counter Flashing (4pc.Kit)	13-1/2"x 13-1/2"
46DVA-CFKS	Counter Flashing (Kit Small)	10-1/2"x 10-1/2"
46DVA-VSK	Vinyl Siding Standoff (4 Pc.Kit)	13-1/2"x 13-1/2"
46DVA-VSKS	Vinyl Siding Standoff (Kit Small)	10-1/2"x 10-1/2"
46DVA-IS	Insulation Shield	9"x 9"
58DVA-WT	Wall Thimble	10-1/2"x 10-1/2"
58DVA-WTS	Wall Thimble (Small)	9"x 9"
58DVA-WTU	Wall Thimble Universal	9"x 9"
58DVA-CS	Ceiling Support	10-3/4"x 10-3/4"
58DVA-FS	Fire Stop	10-1/2"x 10-1/2"
58DVA-WFS	Wall Fire Stop	10-1/2"x 10-1/2"
58DVA-VSS	Vinyl Siding Standoff	19-1/2"x 19-1/2"
56DVA-VSK	Vinyl Siding Standoff (4 Pc.Kit)	16"x 16"
58DVA-CF	Counter Flashing (Assembled)	16"x 16"
58DVA-CFK	Counter Flashing (4pc.Kit)	16"x 16"
58DVA-IS	Insulation Shield	11"x 11"

wall being penetrated is constructed of noncombustible material only, i.e. masonry block, brick, or concrete only, a hole with zero clearance to the vent pipe is permissible if allowed by the appliance manufacturer.

**Notes:**

- (1) The horizontal run of venting must be level, or have a 1/4-inch rise for every 1-foot of run towards the termination. Never allow the vent to run downward. A downward slope can trap heat and become a possible fire hazard.
- (2) The location of the Horizontal Vent Termination on an exterior wall must meet all local and national building

codes, and must not be easily blocked or obstructed. Termination clearances are as follows:

- (a) Clearance above the ground, veranda, porch, deck, or balcony: 12 inches minimum.
- (b) Clearance to a window (operable or fixed closed) or door: 12 inches minimum.
- (c) Vertical clearance to a ventilated soffit located above the Termination Cap (if soffit extends a horizontal distance of 2 feet out over the centerline of the termination): 18 inches minimum.
- (d) Clearance to an unventilated soffit: 12 inches minimum.

# APPENDIX ONE

(e) Clearance to an outside corner: as tested by appliance manufacturer.

(f) Clearance to an inside corner: as tested by appliance manufacturer.

(g) Not to be installed above a meter/regulator assembly within 3 feet horizontally from the centerline of the regulator.

(h) Clearance to a service regulator vent outlet: 6 feet minimum.

(i) Clearance to non-mechanical air supply inlet to a building or the combustion air inlet to any other appliance: 12 inches minimum.

(j) Clearance to a mechanical air supply inlet: 6 feet minimum.

(k) Clearance above a paved sidewalk or paved driveway located on public property: refer to local code.

(l) Clearance under a veranda, porch, deck or balcony: 12 inches minimum.

**Step 4.** Position the Horizontal Termination Cap in the center of the square framed hole, and attach to the exterior wall with the four wood screws provided. Before attaching the vent termination cap to the exterior wall, run a bead of non-hardening silicone sealant around it's outside edges to make a seal between the cap and the wall. The arrow on the vent cap should be pointing up. Ensure that proper clearances to combustible materials are maintained (**Fig. 7**).

## Notes:

(1) The four wood screws provided should be replaced with appropriate

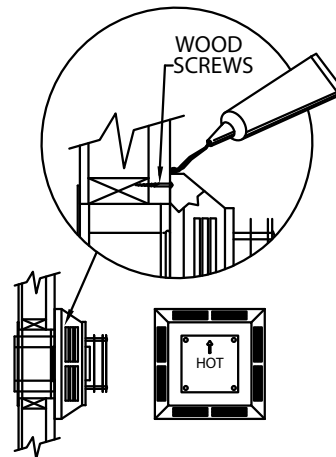


Figure 7

fasteners for use on brick, concrete, block, or other types of sidings.

(2) For buildings with vinyl siding or other surfaces, the Vinyl Siding Standoff or Counter Flashing is available.

**Step 5.** Before connecting your horizontal Pipe Sections to the Horizontal Termination Cap, slide the Wall Thimble Cover over the Pipe Section nearest the interior side of wall (**Fig. 8**).

**Step 6.** Slide the appliance and vent assembly towards the wall, carefully

# APPENDIX ONE

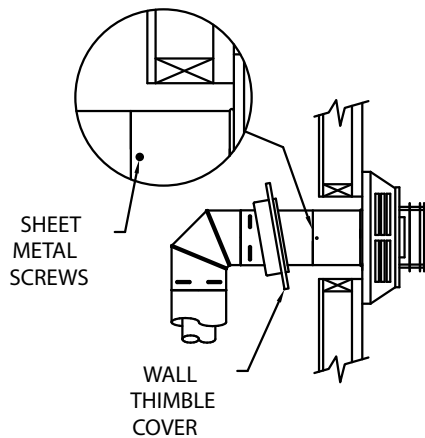


Figure 8

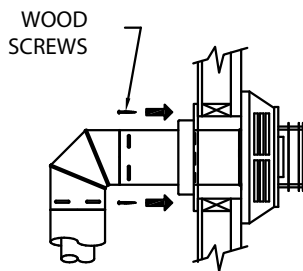


Figure 9

inserting the Pipe Section into the cap assembly. It is important that the Pipe Section extends into the back of the Termination Cap with a minimum overlap of 1-1/4 inches. Use the two sheet metal screws provided to secure the Pipe Section to the back of the Termination Cap. The Wall Thimble Cover will cover the screw heads (**Fig. 8**).

**Step 7.** Slide the Wall Thimble Cover up to the wall surface and attach to the wall with screws provided (**Fig. 9**). Apply optional decorative brass trim to Wall Thimble Cover, if desired.

## SNORKELS

For installations requiring a vertical rise on the exterior of the building, 14-inch and 36-inch tall Snorkel Terminations are available (**Fig. 10**). Follow the same general installation procedures as used for a standard Horizontal Termination. The standard Wall Thimble or Wall Firestop can be used with the Snorkel, but the exterior plate will overhang the edges of the Snorkel. However, a universal Wall Thimble is available for use with the Snorkel that is not visible on the exterior of the building (46 or 58DVA-WTU). To install the Universal Wall Thimble, insert the thimble from the interior of the house and adjust the length of the tube to ensure it touches the backside of the Snorkel when installed (**Fig. 10**). Secure the tube in place using 2 sheet metal screws. Mount the Wall Thimble in place. Attach the Snorkel to the wall using wood screws or other appropriate fasteners, depending on wall construction. If the Snorkel Termination must be installed below grade level, (e.g. in a basement application), proper drainage must be provided to prevent water from entering the Snorkel Termination (**Fig. 11**). Do not attempt to enclose the Snorkel within the wall or any other type of enclosure.



# APPENDIX ONE

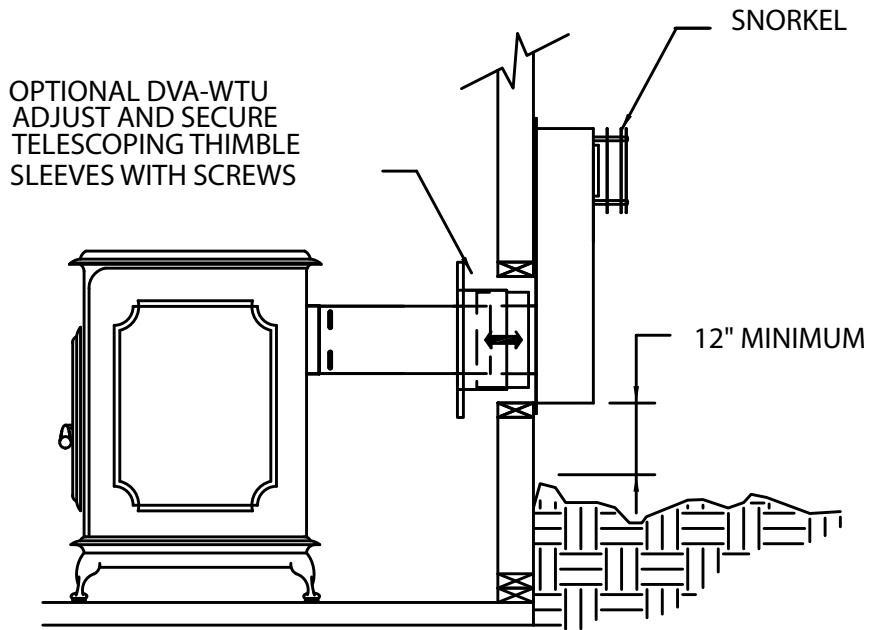


Figure 10

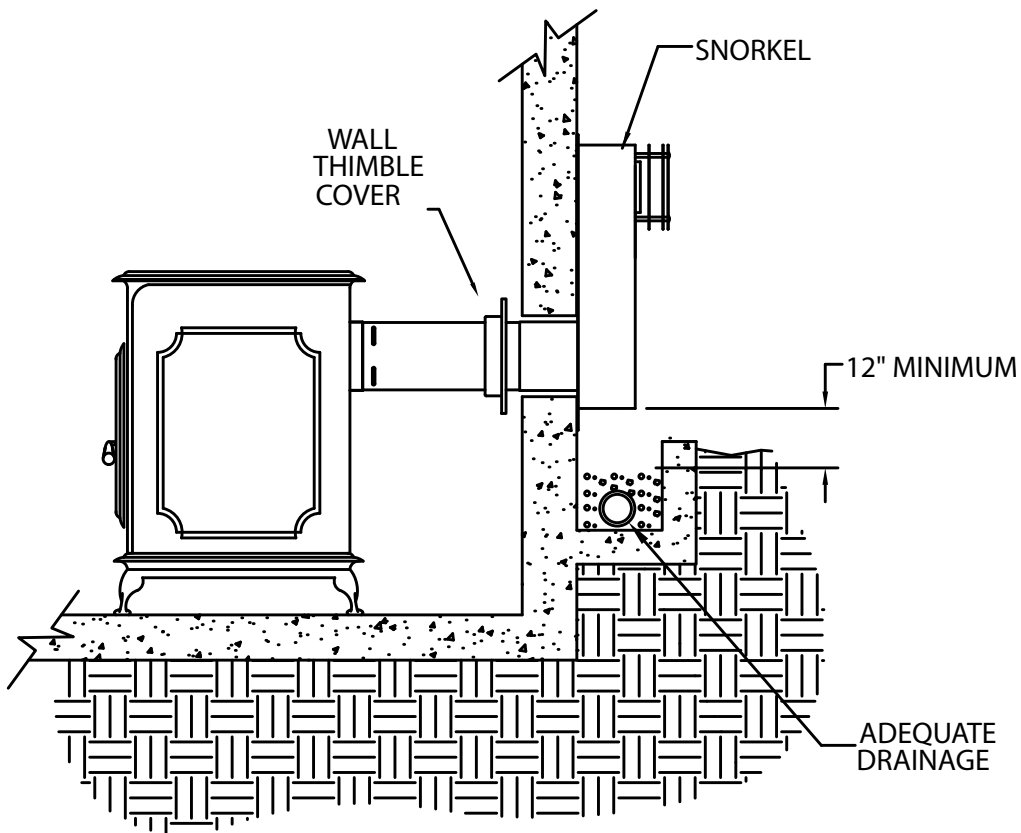


Figure 11

# APPENDIX ONE

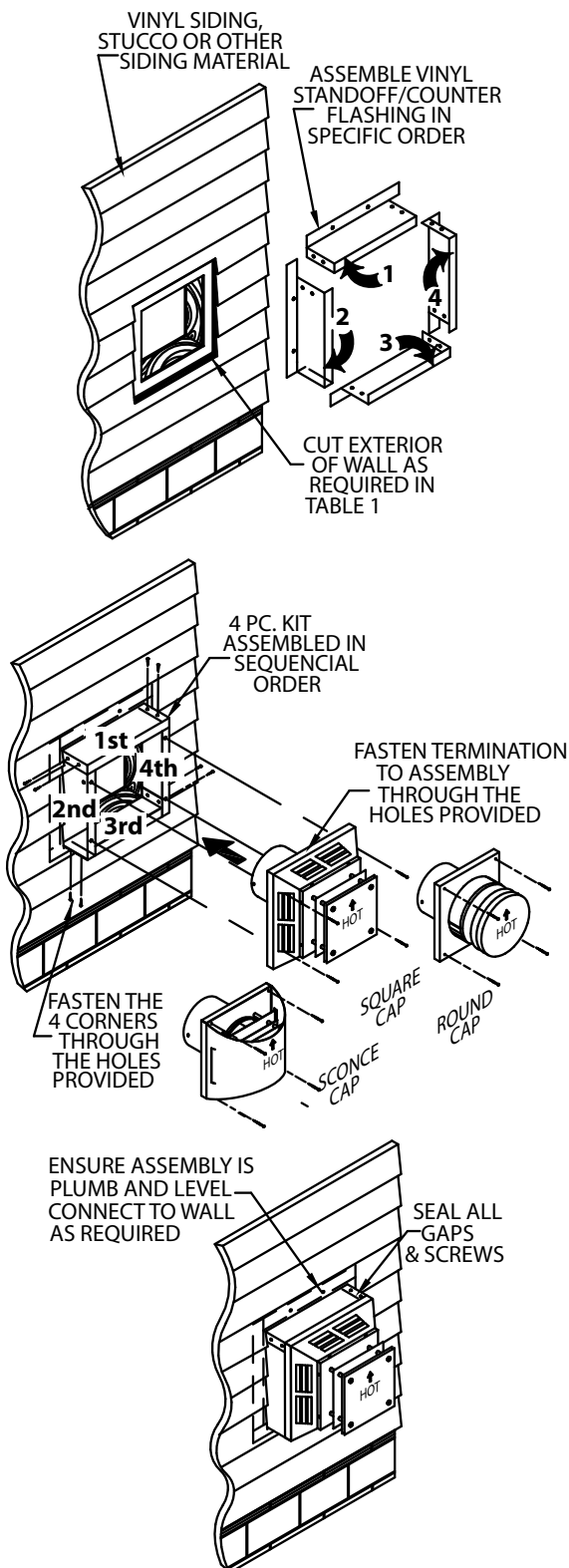


Figure 12

## VINYL SIDING INSTALLATION

The Vinyl Siding Standoff prevents excessive heat from potentially warping or melting the vinyl siding material. Vinyl Siding Standoffs are not used with Snorkels. The Vinyl Siding Standoff is available in either a 1-piece version or a 4-piece version.

### Installing the 1-piece Vinyl Siding Standoff:

Cut a square opening in the vinyl siding centered around the framed opening, in accordance with the dimensions provided in **Table 1, page 8**.

- Mount the Vinyl Siding Standoff to the wall using the screws provided.
- Seal around the perimeter of the Vinyl Siding Standoff using non-hardening waterproof sealant to help ensure a weather tight seal.

- Secure the Horizontal Termination Cap to the Vinyl Siding Standoff using the (4) long screws provided with the cap.

### Installing the 4-piece Vinyl Siding Standoff:

The Vinyl Siding Standoff should be assembled and installed on the wall between the Horizontal Cap and the building exterior. Cut a square opening in the vinyl siding centered around the framed opening, in accordance with the dimensions provided in **Table 1, page 8**.

- The 4 pieces of the Vinyl Siding Standoff (or Counter Flashing) must be assembled in specific order to help ensure a weather tight fit.
- Loosely assemble the four parts, in order, around the opening in the vinyl siding. Place the first of 4 pieces along the upper edge of the opening in the vinyl siding. Progressing counter-

# APPENDIX ONE

clockwise, place the left side, the bottom side, and then the right side around the opening in the siding. Refer to **Figure 12**.

- With the 4 pieces in place secure the pieces together using the pre-drilled holes and the screws provided.
- Seal around the inside corners of the Vinyl Siding Standoff to help ensure a weather tight installation.
- Attach the Horizontal Cap to the Vinyl Siding Standoff. Line up the holes in the cap with the holes in the Vinyl Siding Standoff and secure with the (4) long screws provided with the cap.
- Secure the Vinyl Siding Standoff to the wall as appropriate. Depending on the construction of your wall, different methods of securing the standoff and cap may be required. The Vinyl Siding Standoff's flanges extend 2" under the siding and can be secured to the wall by using screws through the siding and flange if needed.
- Seal around the perimeter of the Vinyl Siding Standoff using non-hardening waterproof sealant to help ensure a weather tight seal.

## COUNTER FLASHING INSTALLATION

The Counter Flashing is typically installed before siding or stucco is finished and helps to ensure a weather tight penetration through the wall. The Counter Flashing allows stucco, or other materials, to be finished up to the edges of the Counter Flashing. Under no circumstances should stucco or other

material cover Termination Cap or air inlets. The Counter Flashing is available in both 1-piece and 4-piece versions.

### Installing the 1-piece counter

**flashing:** Center the counter flashing on the wall around the framed penetration. Secure to the wall using the screws provided or other necessary connector depending on the wall material. Attach the Horizontal Cap to the Counter Flashing by lining up the holes in the cap with the holes in the Counter Flashing. Secure using the 4 long screws provided with the cap (**Fig. 12**).

### Installing the 4-piece Counter

**Flashing:** Attach the 4 pieces together starting with the top piece and work counter-clockwise.

- Secure the 4 pieces together before mounting Counter Flashing to the wall. Mount the assembled Counter Flashing on the wall, centered around the framed wall penetration.
- Depending on wall construction, use screws or other suitable connector through the flanged edges to secure Counter Flashing to the wall.
- Seal around the perimeter of the Counter Flashing using non-hardening waterproof sealant to help ensure a weather tight seal.

**(4)** If the optional copper version of Horizontal Termination Cap is installed, use an appropriate non-combustible material to avoid direct contact between the galvanized and copper metals to prevent possible galvanic reaction.

# APPENDIX ONE

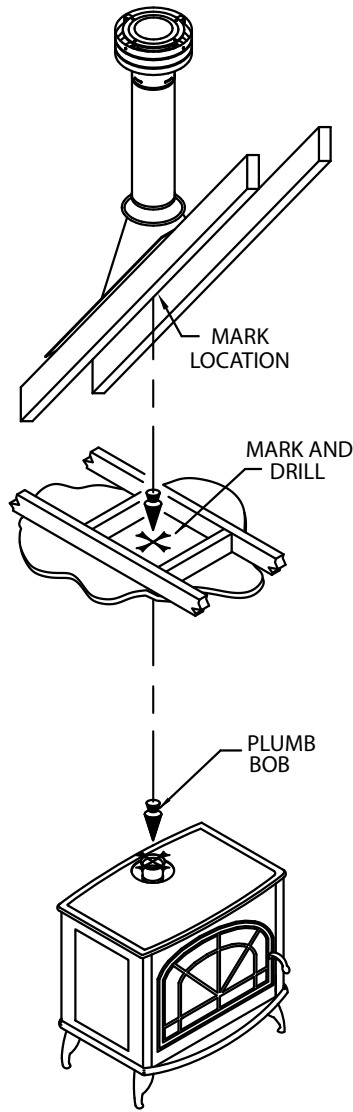


Figure 13

## VERTICAL INSTALLATION

**Step 1.** Check the appliance manufacturer's installation instructions for required clearances (air spaces) to combustibles when passing through ceilings, walls, roofs, enclosures, attic rafters, or other nearby combustible surfaces. Do not pack air spaces with insulation. Check the appliance manufacturer's instructions for maximum vertical rise of the venting system and any maximum horizontal

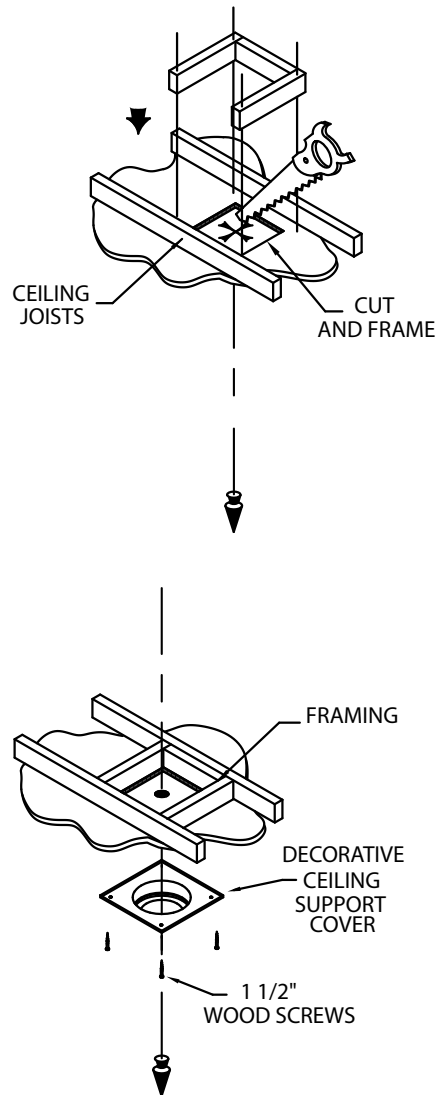


Figure 14

offset limitations.

**Step 2.** Set the gas appliance in the desired location. Drop a plumb bob down from the ceiling to the position of the appliance flue exit, and mark the location where the vent will penetrate the ceiling. Drill a small hole at this point. Next, drop a plumb bob from the roof to the hole previously drilled in the ceiling, and mark the spot where the vent will penetrate the roof

# APPENDIX ONE

**(Fig. 13).** Determine if ceiling joists, roof rafters, framing or other materials will obstruct the venting system. You may wish to relocate the appliance, or to offset, to avoid cutting load-bearing members.

**Step 3.** To install the Round Ceiling Support/Wall Thimble Cover in a flat ceiling, refer to **Table 1, page 8** and cut a square hole in the ceiling (unless otherwise specified by the appliance manufacturer) centered on the hole drilled in Step 2. Frame the hole as shown **(Fig. 14)**.

**Step 4.** If the twist-lock Appliance Adaptor has not been installed on the stove by the manufacturer, install it now in accordance with the appliance instruction manual.

**Step 5.** Assemble the desired Pipe Sections and Elbows necessary to reach from the Appliance Adaptor up through the Round Ceiling Cover or Support Box. Ensure that all Pipe and Elbow connections are in their fully twist-locked position.

**Step 6.** Cut a hole in the roof centered on the small drill hole placed in the roof in Step 2. The opening should be of sufficient size to meet the minimum requirements for clearance to combustibles, as specified by the appliance manufacturer. Continue to assemble Pipe Sections and Elbows as necessary to reach up through the roofline. Galvanized Pipe and Elbows may be utilized in the attic, as well as above the roofline. The galvanized finish is desirable above the roofline, due to higher corrosion resistance.

## Notes:

**(1)** If exact lengths or distances must be met between Elbow offsets or elsewhere, use the Pipe Extensions to adjust onto standard Pipe Sections **(Fig. 15)**.

**(2)** If an offset is necessary in the attic to avoid obstructions, it is important to support the vent pipe in order to avoid excessive stress on the Elbows. Wall Straps or plumbers tape may be used for this purpose **(Fig. 16)**.

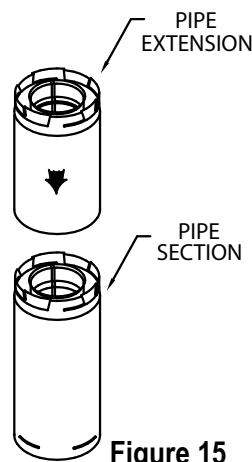


Figure 15

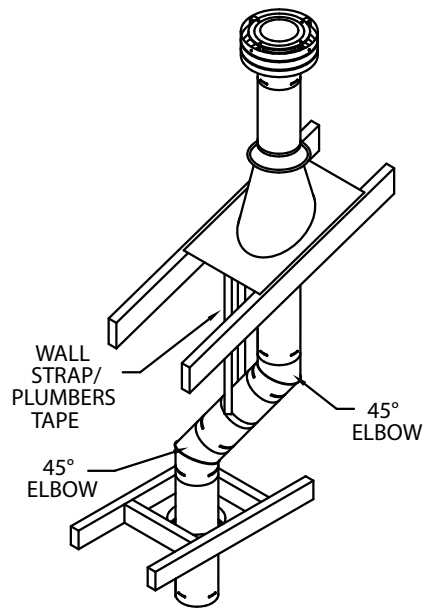


Figure 16

# APPENDIX ONE

ROOF PITCH	MINIMUM HEIGHT	
	Feet	Meters
Flat to 7/12	1	0.3
Over 7/12 to 8/12	1.5	0.46
Over 8/12 to 9/12	2	0.61
Over 9/12 to 10/12	2.5	0.76
Over 10/12 to 11/12	3.25	0.99
Over 11/12 to 12/12	4	1.22
Over 12/12 to 14/12	5	1.52
Over 14/12 to 16/12	6	1.83
Over 16/12 to 18/12	7	2.13
Over 18/12 to 20/12	7.5	2.29
Over 10/12 to 21/12	8	2.44

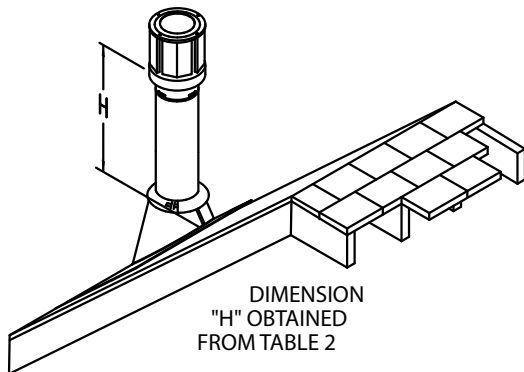


Figure 17

(3) Wherever possible, use 45° Elbows instead of 90° Elbows. The 45° Elbow offers less restriction to the flow of flue gases and intake air.

**Step 7.** Slip the Roof Flashing over the Pipe Section(s) protruding through the roof. Use a non-hardening sealant between the Roof Flashing and the roofing to prevent water leakage. Secure the base of the Roof Flashing to the roof with roofing nails. Ensure the roofing material overlaps the top edge of the Roof Flashing (**Fig. 18**). Verify that you have at least the minimum clearance to combustibles at the roofline and in the attic.

**Step 8.** Continue to add Pipe Sections

until the height of the system (before adding the Cap) meets the minimum building code requirements as described in (**Table 2 and Fig. 17**). Note that for steep roof pitches, the vent height must be increased. In high wind conditions, nearby trees, adjoining rooflines, steep pitched roofs, and other similar factors can result in poor draft, or down drafting. In these cases, increasing the vent height or switching to the High Wind Termination Cap may help to solve the problem.

**Step 9.** Slip the Storm Collar over the Pipe Section, and push it down to the top of the Roof Flashing (**Fig. 18**). Use non-hardening sealant between the Storm Collar and the Pipe Section.

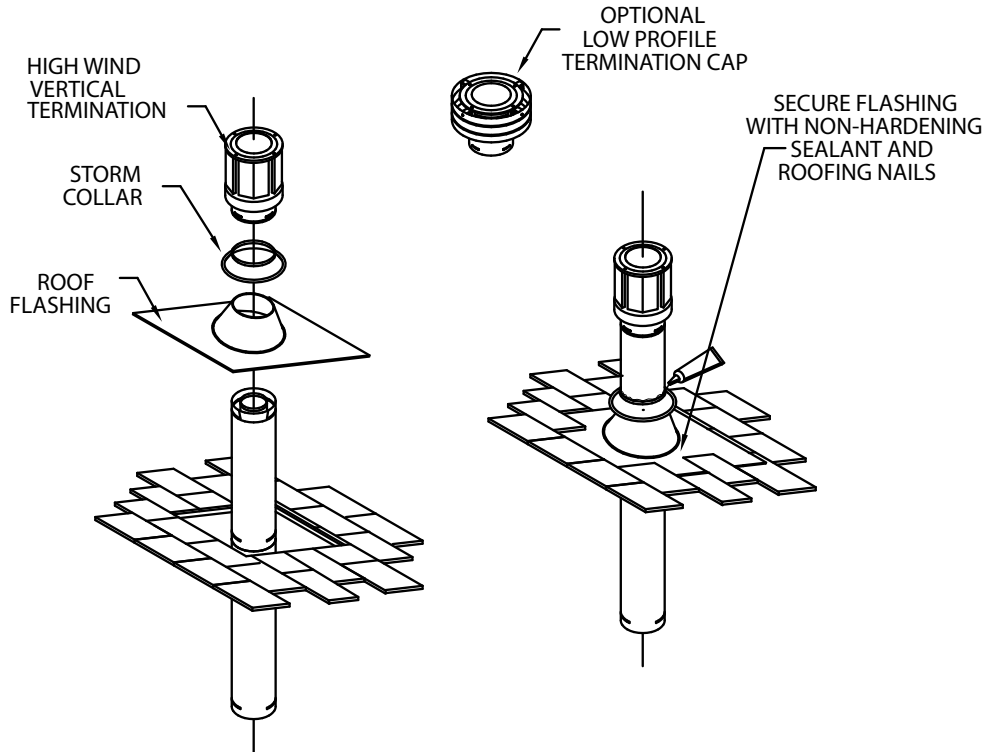
**Step 10.** Holding the bottom of the Termination Cap only, twist lock the cap onto the last Pipe Section protruding above the roofline.

#### Notes:

(1) For multi-story vertical installations, a Ceiling Firestop is required at the second floor, and any subsequent floors (**Fig. 19**). Refer to **Table 1, page 8**. Cut and frame a square opening for installation of the Ceiling Firestop.

(2) If Vent passes through any occupied areas above the first floor, including closets and storage spaces, it must be enclosed. The enclosure may be framed and sheetrocked with standard construction materials, but required clearances to combustibles must be maintained. Consult the appliance manufacturer's installation instructions for the minimum allowable clearance between the outside of

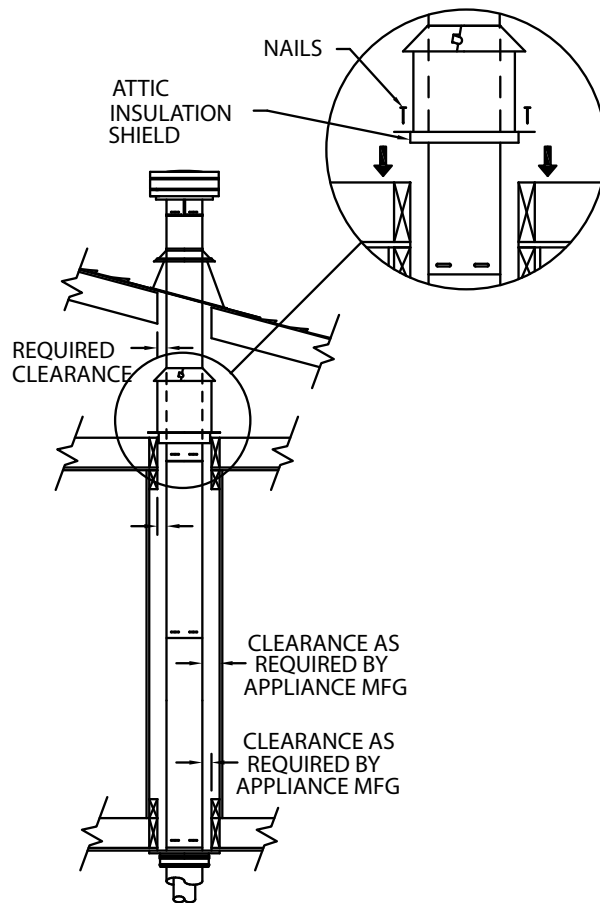
# APPENDIX ONE



**Figure 18**

the vent pipe, and the combustible surfaces of the enclosure. Do not fill required air spaces with insulation.

**(3)** If venting system passes through an attic space the Attic Insulation Shield or a chase enclosure must be installed to prevent contact between Pipe Sections and the insulation or other debris. For the Attic Insulation Shield, nail the base to floor of attic and adjust shield for appropriate insulation level, then attach the collar at the top of assembly (**Fig. 19**). For a chase enclosure, it may be constructed out of sheetrock or similar building materials and framed around the support box or the pipe, maintaining the clearance to combustibles as required by the appliance manufacturer. For vaulted ceilings a chase enclosure must be constructed as the Attic Insulation Shield can not be installed.



**Figure 19**

# APPENDIX ONE

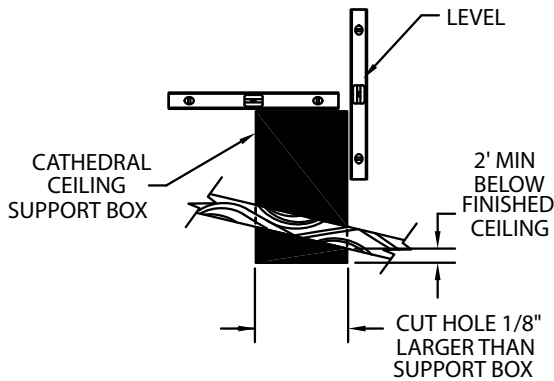


Figure 20

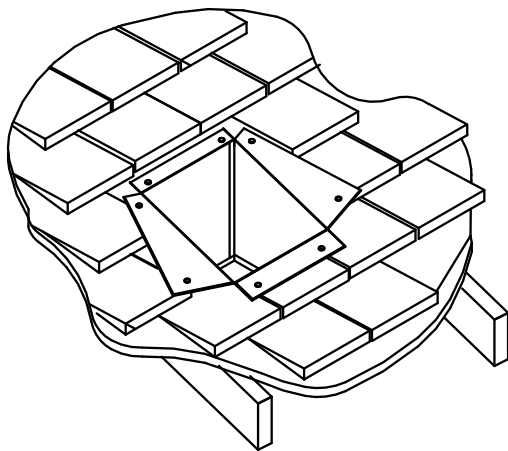


Figure 21

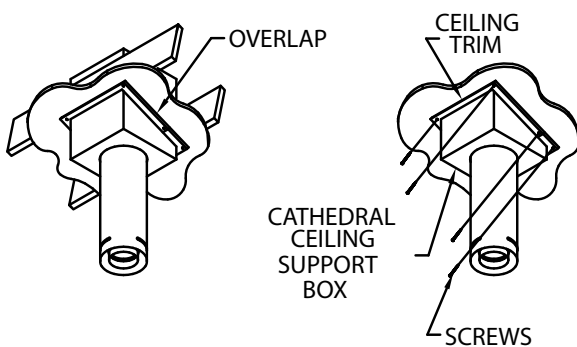


Figure 22

## CATHEDRAL CEILING INSTALLATION

**Step 1.** Follow installation Steps 1 and 2 under Vertical Terminations.

**Step 2.** Using the plumb bob, mark the centerline of the venting system on the ceiling and drill a small hole through the ceiling and roof at this point. From the roof, locate the drill hole and mark the outline of the Cathedral Ceiling Support Box.

**Step 3.** Remove shingles or other roof covering as necessary to cut the rectangular hole for the Support Box (refer to **Table 1** for dimensions). Cut the hole 1/8-inch larger than the Support Box outline.

**Step 4.** Lower the Support Box through the hole in the roof until Support Box protrudes at least 2-inches below the low side of the ceiling (**Fig. 20**). Align the Support Box both vertically and horizontally with a level. Temporarily tack the Support Box in place through the inside walls and into the roof sheathing.

**Step 5.** Using tin snips, cut the Support Box from the top corners down to the roofline, and fold the resulting flaps over the roof sheathing. The flaps may be trimmed as needed (**Fig. 21**). Before nailing it to the roof, run a bead of non-hardening sealant around the Support Box, to make a seal between the Support Box and the roof. Clean out any combustible material from inside the Support Box.

**Step 6.** Follow Steps 4 and 5 (page 14) of the Vertical Installation Instructions.



## APPENDIX ONE

**Step 7.** Place the Support Clamp (provided with the Support Box) inside the Support Box (at the bottom), and secure to the Pipe Section. The Clamp allows the Support Box to support the weight of the Pipe Sections. Continue to add Pipe Sections until you are above the roofline.

**Step 8.** Follow Steps 7 through 10 (page 15 & 16) of the Vertical Installation Instructions.

**Step 9.** Install the black Trim Collar around the outside of the Cathedral Ceiling Support Box. The two pieces of the Trim Collar slide over one another to allow for easy adjustment around the Support Box. Using the six (6) screws provided, secure the four corners and the overlapping sections of the Trim Collar to the underside of ceiling. You may want to pre-drill the holes for the overlapped sections for ease of installation (**Fig. 22**).

# APPENDIX ONE

## GENERAL MAINTENANCE

Conduct an inspection of the venting system every six months. Recommended areas to inspect are as follows:

1. Check areas of the Venting System which are exposed to the elements for corrosion. These will appear as rust spots or streaks, and in extreme cases, holes. These component should immediately be replaced.
2. Remove the Vertical Termination Cap and shine a flashlight down the Vent. Remove any bird nests, or other foreign material.
3. Check for evidences of excessive condensation, such as water droplets forming in the inner liner, and subsequently dripping at joints. Continuous condensate can cause corrosion of caps, pipe, and fittings. It may be caused by having excessive lateral runs, too many elbows, and exterior portions of the system being exposed to cold weather.
4. Inspect joints to verify that no Pipe Sections or Fittings have been disturbed or loosened. Also check mechanical supports such as Wall Straps or plumbers tape for rigidity.

**LABELS** All components are labeled with the appropriate identification information, and the UL listing data, where applicable.

# APPENDIX ONE

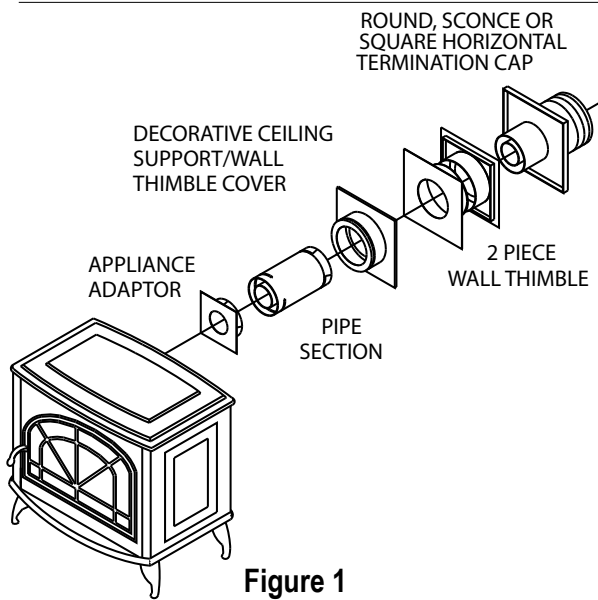


Figure 1

## SUPPLEMENTAL CANADIAN INSTRUCTIONS

When installing DirectVent Pro on appliances in Canada, a 2-piece Wall Thimble is required in order to comply with IR #41 (**Fig. 1 and Fig. 2**). Cut and frame an opening in the wall in accordance with the dimensions in **Table 1, page 8**. Install galvanized exterior Wall Thimble plate on exterior of building and the other half of the Wall Thimble on the interior side of wall. Install Wall Thimble centered through a square framed opening in wall. Install a Wall Thimble Cover on the wall to cover the inside portion of the Wall Thimble. Be sure to maintain all minimum clearances specified by appliance manufacturer. When installing DirectVent Pro vertically through floors (**Fig. 3**) a Ceiling Firestop is required at every floor/ceiling level. Refer to appliance manufacturer installation instructions for complete installation procedure.

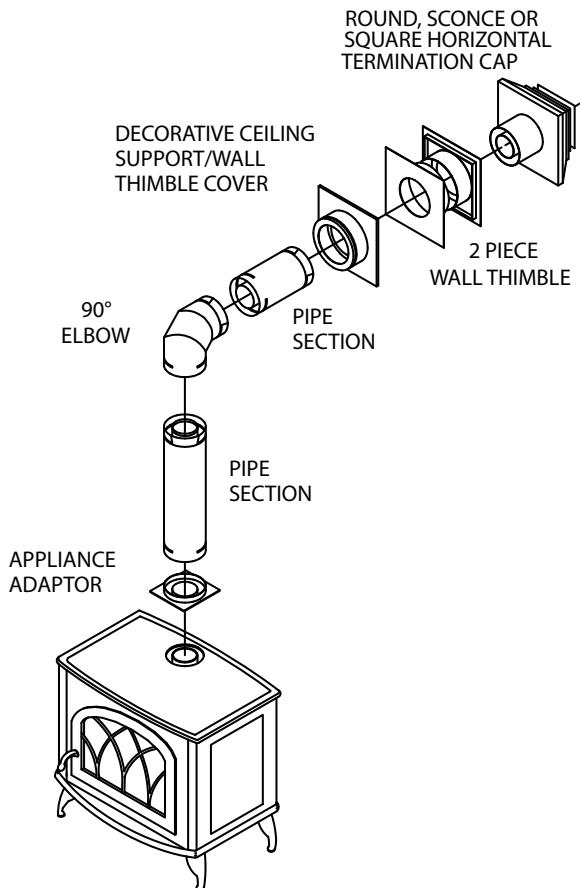
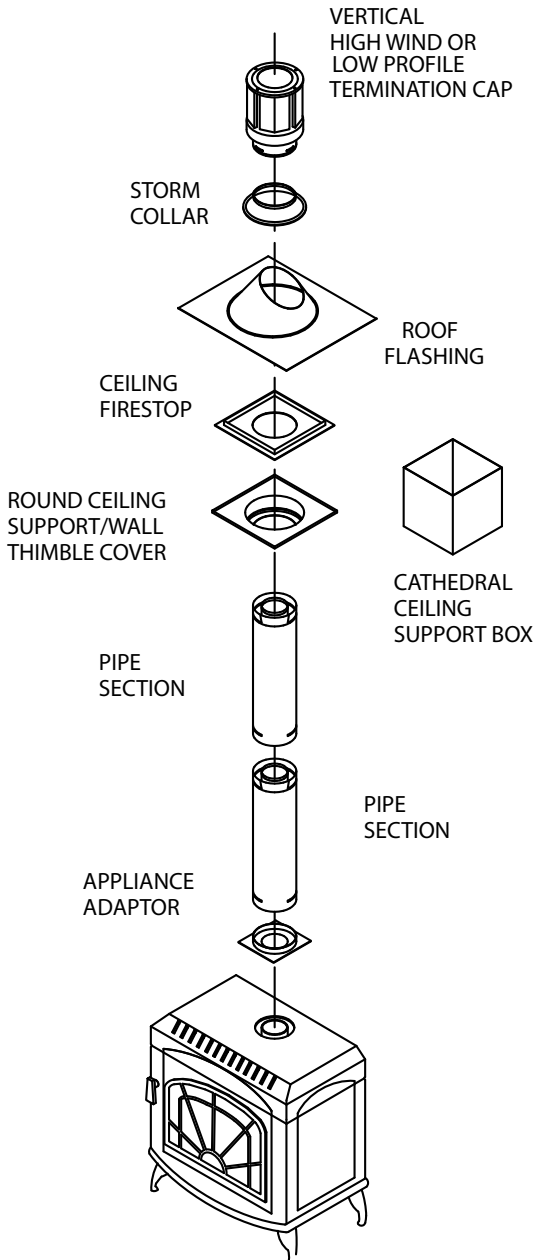


Figure 2

# APPENDIX ONE



**Figure 3**

# APPENDIX ONE

## M&G DURAVENT LIMITED LIFETIME WARRANTY

M&G DuraVent, Inc. ("DuraVent") provides this limited lifetime warranty for all of its products with the exception of Ventinox® (lifetime), and PolyPro® (ten years). Subject to the limitations set forth below, DuraVent warrants that its products will be free from defects in material or manufacturing, if properly installed, maintained and used. DuraVent products are fully warranted if installed only by a professional installer. This Warranty is transferable from the original homeowner to the buyer of the home. This warranty does not cover normal wear and tear, smoke damage or damage caused by chimney fires, acts of God, or any product that was: (1) purchased other than from an authorized DuraVent dealer, retailer or distributor; (2) modified or altered; (3) improperly serviced, inspected or cleaned; or (4) subject to negligence or any use not in accordance with the installation instructions included with the product as determined by DuraVent. Installation instructions are available online at [www.duravent.com](http://www.duravent.com) under Support/Literature and through our Customer Service Department 800-835-4429 or [customerservice@duravent.com](mailto:customerservice@duravent.com). This limited lifetime warranty applies only to parts manufactured by DuraVent.

DuraVent provides the following warranties for its products: One Hundred Percent (100%) MSRP 15 years from the date of purchase, and Fifty Percent (50%) thereafter, except for the following limitations on: all Termination Caps and DuraBlack® are warranted at One Hundred Percent (100%) for five years.

All warranty obligations of DuraVent shall be limited to repair or replacement of the defective product pursuant to the terms and conditions applicable to each product line. These remedies shall constitute DuraVent's sole obligation and sole remedy under this warranty. This warranty provides no cash surrender value. The terms and conditions of this warranty may not be modified, altered or waived by any action, inaction or representation, whether oral or in writing, except upon the express, written authority of an executive officer of DuraVent.

Corn, bio-fuels, driftwood or other wood containing salt, preservative-treated lumber, plastic and household trash or garbage, or wood pellets containing such materials must not be burned in the appliance or fireplace. In case of a chimney fire, the chimney must be inspected and approved by a certified Chimney Sweep before reuse. After each annual inspection, maintenance, and cleaning, the certified Chimney Sweep must fill out and date the appropriate section of the warranty card provided with the chimney liner.

LIMITATIONS ON INTERNET SALES: Notwithstanding any other terms or conditions of this Limited Lifetime Warranty, DuraVent provides no warranty for the following specific products if such products are not installed by a qualified professional installer: DuraTech®, DuraPlus HTC®, DuraChimney® II, PelletVent Pro®, DirectVent Pro®, FasNSeal®, FasNSeal® W2, FasNSeal® Flex, and PolyPro®, and M&G DuraVent's relining products including DuraLiner®, DuraFlex® (SW, Pro, 316, 304), and Ventinox®. For purposes of this warranty, a trained professional installer is defined as one of the following: licensed contractors with prior chimney installation experience, CSIA Certified Chimney Sweeps, NFI Certified Specialists, or WETT Certified Professionals.

DuraVent must be notified and given the opportunity to inspect defective product prior to replacement under the terms of this limited lifetime warranty. All warranty claims must be submitted with proof of purchase. Labor and installation costs are not covered under this warranty. To obtain warranty service contact: DuraVent Warranty Service, 877 Cotting Ct., Vacaville CA 95688, or call 800-835-4429.

WHERE LAWFUL, DURAVENT DISCLAIMS ALL OTHER WARRANTIES, INCLUDING BUT NOT LIMITED TO IMPLIED WARRANTIES OF MERCHANTABILITY AND FITNESS FOR A PARTICULAR PURPOSE. IN NO EVENT WILL DURAVENT BE LIABLE FOR INCIDENTAL, CONSEQUENTIAL, PUNITIVE OR SPECIAL DAMAGES OR DIRECT OR INDIRECT LOSS OF ANY KIND, INCLUDING BUT NOT LIMITED TO PROPERTY DAMAGE AND PERSONAL INJURY. DURAVENT'S ENTIRE LIABILITY IS LIMITED TO THE PURCHASE PRICE OF THIS PRODUCT. SOME STATES DO NOT ALLOW LIMITATIONS ON IMPLIED WARRANTIES, OR THE EXCLUSION OR LIMITATION OF INCIDENTAL OR CONSEQUENTIAL DAMAGES, SO THE ABOVE LIMITATIONS AND EXCLUSIONS MAY NOT APPLY TO YOU. THIS LIMITED WARRANTY GIVES YOU SPECIFIC LEGAL RIGHTS, AND YOU MAY ALSO HAVE OTHER RIGHTS THAT VARY FROM STATE TO STATE.

For the most up-to-date installation instructions, see [www.duravent.com](http://www.duravent.com)

REV 3.22.2012

Manufactured in Vacaville CA and Albany NY

# DuraVent

Member of  M&G Group

**Customer Service Support 800-835-4429 707-446-4740 FAX [www.duravent.com](http://www.duravent.com)**

DirectVent Pro is a registered trademark of the M&G DuraVent, Inc.

All rights reserved. Made in the USA. M&G DuraVent is a member of M&G Group. ©2012

L954 5/2012

# APPENDIX TWO

## MASSACHUSETTS CERTIFICATION

This appliance is approved for installation in the Commonwealth of Massachusetts. The Board of State Examiners of Plumbers and Gas Fitters has issued approval number G1-1212-217 for this appliance.

### **The following must be observed when installing the Element4 fireplaces within the Commonwealth of Massachusetts:**

(a) For all side wall horizontally vented gas fueled equipment installed in every dwelling, building or structure used in whole or in part for residential purposes, including those owned or operated by the Commonwealth and where the side wall exhaust vent termination is less than seven (7) feet above finished grade in the area of the venting, including but not limited to decks and porches, the following requirements shall be satisfied:

1. **INSTALLATION OF CARBON MONOXIDE DETECTORS.** At the time of installation of the side wall horizontal vented gas fueled equipment, the installing plumber or gasfitter shall observe that a hard wired carbon monoxide detector with an alarm and battery back-up is installed on the floor level where the gas equipment is to be installed. In addition, the installing plumber or gasfitter shall observe that a battery operated or hard wired carbon monoxide detector with an alarm is installed on each additional level of the dwelling, building or structure served by the side wall horizontal vented gas fueled equipment. It shall be the responsibility of the property owner to secure the services of qualified licensed professionals for the installation of hard wired carbon monoxide detectors

a. In the event that the side wall horizontally vented gas fueled equipment is installed in a crawl space or an attic, the hard wired carbon monoxide detector with alarm and battery back-up may be installed on the next adjacent floor level.

b. In the event that the requirements of this subdivision can not be met at the time of completion of installation, the owner shall have a period of thirty (30) days to comply with the above requirements; provided, however, that during said thirty (30) day period, a battery operated carbon monoxide detector with an alarm shall be installed.

2. **APPROVED CARBON MONOXIDE DETECTORS.** Each carbon monoxide detector as required in accordance with the above provisions shall comply with NFPA 720 and be ANSI/UL 2034 listed and IAS certified.

3. **SIGNAGE.** A metal or plastic identification plate shall be permanently mounted to the exterior of the building at a minimum height of eight (8) feet above grade directly in line with the exhaust vent terminal for the horizontally vented gas fueled heating appliance or equipment. The sign shall read, in print size no less than one-half (½) inch in size, "GAS VENT DIRECTLY BELOW. KEEP CLEAR OF ALL OBSTRUCTIONS".

4. **INSPECTION.** The state or local gas inspector of the side wall horizontally vented gas fueled equipment shall not approve the installation unless, upon inspection, the inspector observes carbon monoxide detectors and signage installed in accordance with the provisions of 248 CMR 5.08(2)(a)1 through 4.

(b) **EXEMPTIONS:** The following equipment is exempt from 248 CMR 5.08(2)(a)1 through 4:

1. The equipment listed in Chapter 10 entitled "Equipment Not Required To Be Vented" in the most current edition of NFPA 54 as adopted by the Board; and

2. Product Approved side wall horizontally vented gas fueled equipment installed in a room or structure separate from the dwelling, building or structure used in whole or in part for residential purposes.

(c) **MANUFACTURER REQUIREMENTS - GAS EQUIPMENT VENTING SYSTEM PROVIDED.** When the manufacturer of Product Approved side wall horizontally vented gas equipment provides a venting system design or venting system components with the equipment, the instructions provided by the manufacturer for installation of the equipment and the venting system shall include:

1. Detailed instructions for the installation of the venting system design or the venting system components; and

2. A complete parts list for the venting system design or venting system.

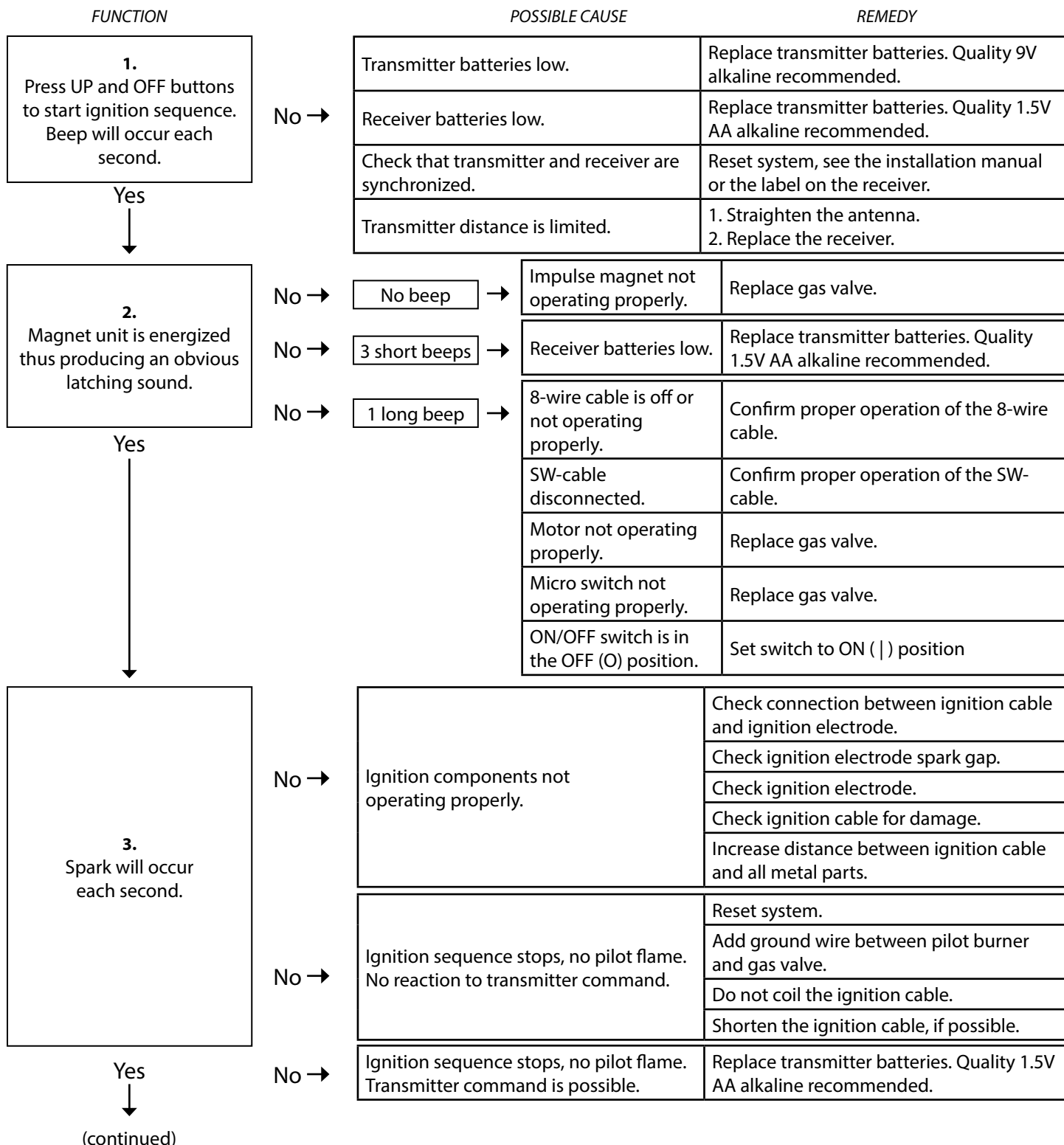
(d) **MANUFACTURER REQUIREMENTS - GAS EQUIPMENT VENTING SYSTEM NOT PROVIDED.** When the manufacturer of a Product Approved side wall horizontally vented gas fueled equipment does not provide the parts for venting the flue gases, but identifies "special venting systems", the following requirements shall be satisfied by the manufacturer:

1. The referenced "special venting system" instructions shall be included with the appliance or equipment installation instructions; and

2. The "special venting systems" shall be Product Approved by the Board, and the instructions for that system shall include a parts list and detailed installation instructions.

(e) A copy of all installation instructions for all Product Approved side wall horizontally vented gas fueled equipment, all venting instructions, all parts lists for venting instructions, and/or all venting design instructions shall remain with the appliance or equipment at the completion of the installation.

# APPENDIX THREE



# APPENDIX THREE

FUNCTION		POSSIBLE CAUSE	REMEDY
<b>4.</b> Pilot lit.  Yes ↓	No →	TC- and SW-cable reversed.	Check cable connection between receiver and interrupter block.
		Magnet unit not operating properly.	Replace gas valve.
		Short between interrupter and SW cable.	Check interrupter block connection.
		No gas (magnet unit drops after 30 second audible count.)	Check gas supply.
		Spark not lighting the pilot.	Check spark is crossing pilot orifice.
<b>5.</b> Sparking stops after pilot is lit.  Yes ↓	No →	Short between interrupter and TC-cable.	Check connection to interrupter block.
		Electronic measuring amplifier defective.	Replace the receiver.
<b>6.</b> Motor turns to main gas and pilot stays lit.  Yes ↓	No →  Magnet unit drops (audible sound)	Resistance in thermocouple circuit too high.	Check thermocouple circuit.
		Not enough heat on thermocouple.	Check position of pilot to thermocouple and intensity of pilot flame.
		Low voltage from thermocouple.	Replace thermocouple. Do not over tighten - hand tight + ¼ turn maximum.
		No gas (magnet unit drops after 30 second audible count.)	Check gas supply.
	No →	Broken receiver	Ensure powered/unpowered receiver allows manual operation.
		No →  Ignition sequence stops. No reaction to transmitter command.	Reset system.
			Add ground wire between pilot burner and gas valve.
			Do not coil the ignition cable. Shorten the ignition cable, if possible.
<b>7.</b> Main burner is lit.  Yes ↓	No →	Manual knob is in the "MAN" position.	Turn the control knob to "ON" position (positive latch is required.)
<b>8.</b> Main burner stays lit.  Yes ↓	No →	Too much draft at pilot flame (poor flame impingement of thermocouple.)	Check installation.
		2 <sup>nd</sup> thermocouple is not heated.	Ensure 2 <sup>nd</sup> thermocouple is in the flame. Check 2 <sup>nd</sup> thermocouple wiring.
<b>9.</b> Magnet unit drops while motor turns. 3 beeps.  No ↓ <b>NORMAL OPERATION</b>	Yes →	Receiver batteries low.	Replace transmitter batteries. Quality 1.5V AA alkaline recommended.



# NOTES

---

---

---

---

---

---

---

---

---

---

---

---

---

---

---

---

---

---

---

---

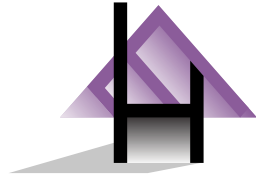
---

---

---

---

---



EuropeanHome

**EUROPEAN HOME**

a division of Europa Ja, Inc.

376 Washington Street

Suite 203

Malden, MA 02148

[www.europeanhome.com](http://www.europeanhome.com)