

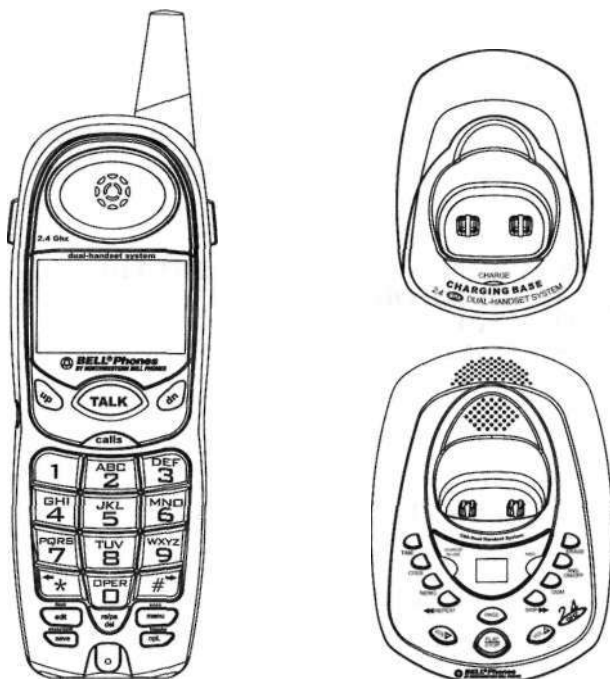

BELL Phones

BY NORTHWESTERN BELL PHONES

36028



Congratulations on your selection of the 36028 from Northwestern Bell Phones. This quality 2.4GHz Dual-handset System cordless telephone with Digital Answering System and Call Waiting Caller ID, like all Genuine BELL® products, has been designed to give you many years of continuous service and represents the best value for your money. It requires little maintenance and is easy to setup and operate.

IMPORTANT SERVICE INFORMATION

Read this manual before attempting to setup or use this instrument. It contains important information regarding safe installation and use. Keep this manual for future reference. Also save the carton, packing and proof of purchase to simplify and accelerate any needed action. If you need assistance or service, call (800) 888-8990 between 8:00 a.m. and 4:30 p.m. Pacific Standard Time, Monday through Friday. You can also visit our web site at <http://www.nwbphones.com> for technical support and information on our other products.

! WARNING

To prevent fire or shock hazard, do not expose this product to rain or any type of excess moisture. If accidentally dropped into water, the AC adapter should immediately be unplugged from the wall along with the telephone line cord.

THIS SYMBOL IS INTENDED TO ALERT THE USER OF THE PRESENCE OF IMPORTANT OPERATING AND MAINTENANCE (SERVICING) INSTRUCTIONS IN THE OWNER'S MANUAL.

36028

CARTON CONTENTS

- 36028 Base and Handset
- Rechargeable Ni-Cd Battery Pack
- Telephone Line Cord
- AC Adapter
- User's Manual
- Warranty Card
- Accessory Order Form

SAVE THESE INSTRUCTIONS

IMPORTANT SAFETY

! INSTRUCTIONS

When using your telephone equipment, basic safety precautions should always be followed to reduce the risk of fire, electric shock, and injury to persons, including the following:

1. Read and understand all instructions.
2. Follow all warnings and instructions marked on the product.
3. Unplug this product from the wall outlet before cleaning. Do not use liquid cleaners or aerosol cleaners. Use a damp cloth for cleaning.
4. Do not use this product near water, for example, near a bathtub, wash bowl, kitchen sink, or laundry tub, in a wet basement or near a swimming pool.
5. Do not place this product on an unstable cart, stand, or table. The product may fall, causing serious damage to the product.
6. Slots and openings in the cabinet and the back or bottom are provided for ventilation, to protect it from overheating. These openings should never be blocked or covered. The openings should never be blocked by placing the product on the bed, sofa, rug, or other similar surface. This product should never be placed near or over a radiator or heat register. This product should not be placed in a built-in installation unless proper ventilation is provided.
7. This product should be operated only from the type of power source indicated on the marking label. If you are not sure of the type of power supply to your home, consult your dealer or local power company.
8. Do not allow anything to rest on the power cord. Do not locate this product where the cord will be abused by persons walking on it.
9. Do not overload wall outlets and extension cords as this can result in the risk of fire or electric shock.
10. Never push objects of any kind into this product through cabinet slots as they may touch dangerous voltage points or short out parts that could result in a risk of fire or electric shock. Never spill liquid of any kind on the product.
11. To reduce the risk of electric shock, do not disassemble this product, but take it to a qualified service contractor when some service or repair work is required. Opening or removing covers may expose you to dangerous voltages or other risks. Incorrect reassembly can cause electric shock when the appliance is subsequently used.
12. Unplug this product from the wall outlet and refer servicing to qualified service personnel under the following conditions:
 - A. When the power supply cord or plug is damaged or frayed.
 - B. If liquid has been spilled into the product.
 - C. If the product has been exposed to rain or water.
 - D. If the product does not operate normally by following the operating instructions. Adjust only those controls that are covered by the operating instructions. Improper adjustments of other controls may result in damage and will often require extensive work by a qualified technician to restore the product to normal operation.
 - E. If the product has been dropped or the cabinet has been damaged.
 - F. If the product exhibits a distinctive change in performance.
13. Avoid using a telephone (other than a cordless type) during an electrical storm. There may be a remote risk of electric shock from lightning.
14. Do not use the telephone to report a gas leak in the vicinity of the leak.

INSTALLATION

! PRECAUTIONS

1. Never install telephone wiring during a lightning storm.
2. Never install telephone jacks in wet locations unless the jack is specifically designed for wet locations.
3. Never touch uninsulated telephone wires or terminals unless the telephone line has been

disconnected at the network interface.

4. Use caution when installing or modifying telephone lines.

! MAINTENANCE

1. Use a damp cloth to clean the plastic cabinet. A mild soap will help to remove grease or oil. Never use polish, solvents, abrasives or strong detergents since these can damage the finish.
2. Your phone should be situated away from heat sources such as radiators, heaters, stoves or any other appliance that produces heat.

! CAUTION

Risk of explosion if battery is replaced by an incorrect type. Dispose of used batteries according to the instruction, read and follow these instructions:

1. Use only the 3.6V, 450mAh, Ni-Cd battery pack .
2. Do not dispose of the battery in a fire. The cell may explode. Check with local codes for possible special disposal instructions.
3. Do not open or mutilate the battery. Released electrolyte is corrosive and may cause damage to the eyes or skin. It may be toxic if swallowed.
4. Exercise care in handling the battery in order not to short the battery with conducting material such as rings, bracelets and keys. The battery or conductor may overheat and cause burns.
5. Recharge only the battery provided with or identified for use with this product. The battery may leak corrosive electrolyte or explode if it is not the correct type.
6. Do not attempt to rejuvenate the battery provided with or identified for use with this product by heating them. Sudden release of the battery electrolyte may occur causing burns or irritation to eyes or skin.
7. When inserting the battery into this product, the proper polarity or direction must be observed. Reverse insertion of batteries can cause charging that may result in leakage or explosion.
8. Do not store this product, or the battery provided with or identified for use with this product, in high-temperature areas. Batteries that are stored in a freezer or refrigerator for the purpose of extending shelf life should be stabilized at room temperature prior to use after cold storage.
9. Disconnect telephone lines before installing batteries.

SAVE THESE INSTRUCTIONS

! FCC NOTICE

The FCC requires that you be advised of certain requirements involving the use of this telephone.

1. This telephone is hearing aid compatible.
2. This equipment complies with 47 CFR Part 68 requirement. On the bottom of this equipment is a label that contains, among other information, the ACTA registration number and Ringer Equivalence Number (REN) for this equipment. If requested, provide this information to your telephone company.
3. The REN is useful to determine the quantity of devices you may connect to your telephone line and still have all of those devices ring when your number is called. In most, but not all areas, the sum of the RENs of all devices should not exceed five (5.0). To be certain of the number of devices you may connect to your line, as determined by the REN, you should call your local telephone company to determine the maximum REN for your calling area.
4. If your telephone causes harm to the telephone network, the telephone company may discontinue your service temporarily. If possible, they will notify you in advance. But if advance notice is not practical, you will be notified as soon as possible. You will be advised of your right to file a complaint with the FCC.
5. Your telephone company may make changes to its facilities, equipment, operations or procedures that could affect the proper operation of your equipment. If they do, you will be given advance notice so as to give you an opportunity to maintain uninterrupted service.
6. If you experience trouble with the telephone, please contact VTC Service & Manufacturing Co., Inc at (800) 888-8990 or write to: VTC Customer Service, 16988 Gale Ave., City of Industry, CA

91745 for repair/warranty information. The telephone company may ask you to disconnect this equipment from the network until the problem has been corrected or you are sure that the equipment is not malfunctioning.

8. This equipment may not be used on coin service provided by the telephone company. Connection to party lines is subject to state tariffs. (Contact your state public utility commission or corporation commission for information.)
9. USOC jack type is RJ11C and the compatible jack is part 68 compliance.

NOTICE: If your home has specially wired alarm equipment connected to the telephone line, ensure the installation of this [equipment ID] does not disable your alarm equipment. If you have questions about what will disable alarm equipment, consult your telephone company or a qualified installer.

This device complies with Part 15 of the FCC Rules. Operation is subject to the following two conditions: (1) This device may not cause harmful interference, and, (2) his device must accept any interference received, including interference that may cause desired operation. Privacy of communications may not be ensured when using this phone.

Changes or modifications not expressly approved in writing by Northwestern Bell Phones may void the user's authority to operate this equipment.

Some cordless phones operate at frequencies that may cause interference to nearby TVs and VCRs; to minimize or prevent such interference, the base of the cordless phone should not be placed near or on top of a TV or VCR; and, if interference is experienced, moving the cordless telephone farther away from the TV or VCR will often reduce or eliminate the interference.

! AC ADAPTOR: Use only with Class 2 Transformer, 9VDC output, 500mA for base unit and 9VDC output , 200mA for charger, center pin positive.

36028 CONTROLS DIAGRAM

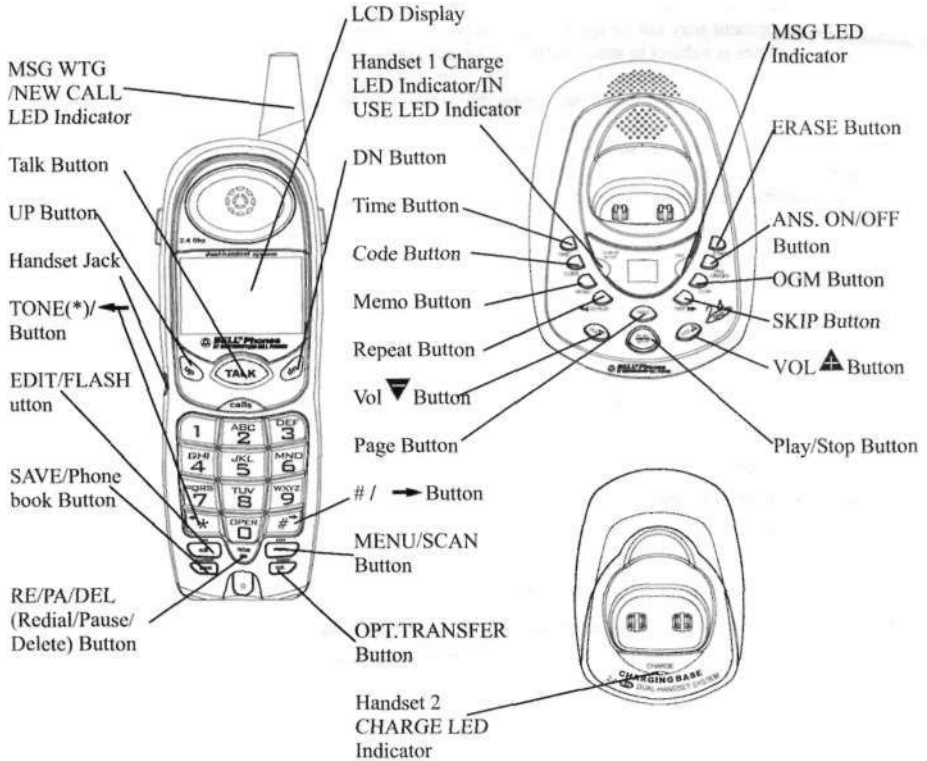

Base Unit
(Rear View)

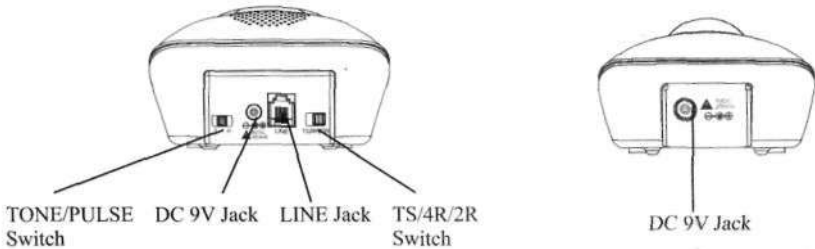

DESCRIPTIONS

HANDSET CONTROL:

LCD Display - Shows call information, phone status, prompts and Phonebook items.

MSG WTG /NEW CALL Indicator - Blue LED blinks when you have new message(s) and call(s).

TALK Button - Press this button to place a call, answer a call, or end a call.

SAVE/PHONE BOOK button - Saves the changes on the listed items. Allows you to retrieve a memory(name and phone number)for the personal Phonebook (up to 20 memories).

-tone */ ← Button - Press to move left on the large LCD Display

/ → Button - Press to move right on the large LCD Display.

EDIT/ FLASH Button -(EDIT) Press to edit listed items. (FLASH) Momentarily hangs up the phone to access custom calling features such as Call waiting or Three-way calling provided by you local phone company.

UP/DN Button - Allows you to adjust the handset volume (3 steps) in TALK mode. It also allows you to view the caller list or /and Phone.

Microphone - Used for speaking with callers.

Headset Jack - A jack located on the side of the handset used for connecting your headset to enjoy a hands-free communication.

RE/PA/DEL(Redial/Pause/Deletc) Button - (Redial)Press to redial the last number you dialed.(Pause)Press to insert pause while dialing. (Delete)Press and hold down to delete items.

Calls Button - Press to see the caller list.

OPT (Option) /TRANSFER Button - During you view the caller list, press to place a long distance call or to place a local call. Allow you to transfer to other handset during a call. During a call, the source handset user can press the OPT/TRANSFER button followed by destination handset. The call is quick transferred to the destination handset, it starts ringing and shows "TRANSFER". If destination handset user does not answer the call with 30 sec, source handset will be ring back for 30 sec.

MENU/SCAN - While in standby mode, this button allows you to set the handset in Programming mode. While in Talk mode. It is used to manually select one of the 40 operating channels when you experience interference on the handset.

Receiver - Allows you to hear calls.

BASE UNIT CONTROLS:

Base Unit Charge Terminals - Used for charging handsel batteries. We recommend that you clean these contacts periodically with an alcohol-moistened cloth or cotton swab.

IN USE Indicator -Lights up steadily when the phone is in talk mode and turns off when the handset is not in use.

CHARGE LED Indicator - Lights up steadily when paging the handset. Lights up steadily when the handset is being charged on the base and turns off when the handset is removed from its cradle.

MSG LED Indicator - Flashes rapidly if the system has new memo message(s) and new incoming messages(s).

PAGE Button - Allows you to locate the handset when it is not on the base, or to alert the person near the handset.

Volume Control \ll / \bullet **Button** -Adjusts the base unit speaker volume level.

PLAY/STOP Button - Press to play back the incoming Message(s)(ICM) and Memo message(s) or to stop current activity.

ANS. ON/OFF - Press to activate or deactivate answer function.

REPEAT $\bullet\bullet\bullet$ **Button** - Press to skip to the previous message during playback.

SKIP $\gg\bullet$ **Button** - Press to skip to the next message during playback.

ERASE Button - Press to erase a single message or all messages in order to conserve message space in memory.

Memo Button - Press to record Memo message.

OGM Button - Press to record Outgoing Message(OGM).

TIME SET Button - Press to set the day and time stamp.

CODE Button - Press to set the password for remote operation.

Ring (TS/4R/2R) Switch -Allows you to select the appropriate ringing..

TONE/PULSE Switch - A switch located on the rear of the base unit, which allows you to set the dialing mode to either Tone dialing or Pulse(rotary) dialing.

DC 9V jack - A jack located on the rear side of the base unit used for connecting the AC adaptor to the base unit.

TEL LINE jack - Accepts line cord to make connection with modular type telephone outlet.

INSTALLATION

CAUTION: USE ONLY THE NICKEL CADMIUM (Ni-Cd) BATTERY TYPE INCLUDED WITH THIS UNIT. USE OF OTHER BATTERY TYPES MAY CAUSE INJURIES OR DAMAGE.

Battery Installation

1. Remove the battery compartment cover of the handset by pressing the top of the cover and sliding it down.
2. Connect the Ni-Cd battery pack plug along the slot into the handset's battery connector as shown below.

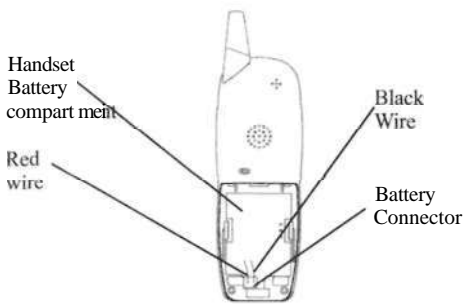

(Figure 1)

3. Insert the Ni-Cd battery into the battery compartment.
4. Replace the battery compartment cover by sliding it up towards the handset.
NOTE: Use the type and size of Ni-Cd battery pack, 3.6V, 450mAh. It is recommended that the Ni-Cd battery pack should be fully charged overnight prior to initial use.

Belt Clip Installation

With the back of handset facing up, insert one side of the belt clip hook into the matching slots at the top side of handset as shown in Figure2. Slide the other hook until it locks into place from the opposite side of the handset.



(Figure 2)

POWER CONNECTION

CAUTION: You must use a Class II, 120 Volt AC/9 Volt DC adaptor that delivers at least 500mA for base unit and 200mA for charger. The center tip must be positive and the plug must correctly fit the base unit's DC 9V 500mA jack and fit the charger DC 9V 200mA jack.

1. Plug the AC adaptor into a standard AC outlet.
2. Insert the small plug into the DC 9V 500mA jack on the rear of the base unit and Insert the small plug into the DC 9V 200mA on the rear of the charger as shown in Figure 3.

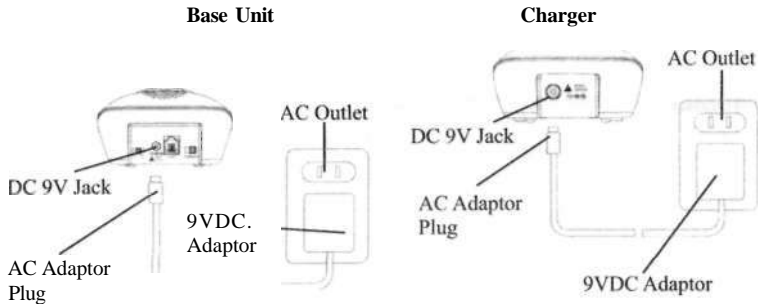

(Figure3)

HEADSET CONNECTION

One of the special features of your phone is that your handset could utilize a headset (not included) for hands-free communication. Insert the small plug at the end of your headset cord to the headset jack at the side of the handset as shown in Figure 4. Follow the procedures discussed in "Placing a Call" when to place and receive a call.

Note: The headset jack of your cordless telephone is compatible with 2.5mm headset plugs only. When you plug in the headset into the headset jack, it automatically mutes the microphone and speaker of the handset. Unplug the headset to return the handset to normal use.

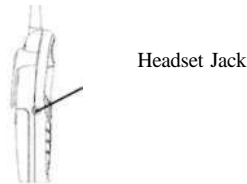

(Figure 4)

INITIAL SETUP

Please follow these steps before using the cordless telephone for the first time.

1. Ensure that the handset battery pack is installed and charged fully for at least 14 hours.
2. Ensure that all connections(line cord and adaptor cord) are properly inserted into rear of the base unit.

SETTING THE TONE/PULSE MODE

Select the appropriate dialing service by moving the TONE/PULSE switch at the bottom of the base unit:

- TONE for Tone service , or
- PULSE for Rotary service.

SETTING THE HANDSET RINGER ON/OFF MODE

The handset must be set to ring ON mode in order to ring when receiving an incoming call. See Programs Operation section on "RING ON/OFF SETTING".

TELEPHONE OPERATION

Place a Call

1. Pick up the handset and press the TALK button. The Call Timer starts to count. The base unit IN USE LED indicator will light up.

2. Listen for a dial tone.
3. Dial the telephone number. The phone numbers appear on the LCD Display as you enter the number.
4. When finished with your call, press the TALK button or place the handset on the base unit.

NOTE: The call timer will start to count once you press the TALK button.

Receive a Call

NOTE: If you are expecting incoming calls, the handset must be programmed to **RING ON** mode.

If the handset is on the base:

1. When the phone rings, simply pick up the handset from the base cradle if the unit is set to auto-answer ON mode. If the unit is set to auto-answer OFF mode, press the TALK button. See the "AUTO ANSWER ON/OFF" section to set auto-answer mode. The LCD Display will show "TALK".
2. Start your conversation.
3. To end your conversation, either press the TALK button or place the handset on the base unit.

If the handset is out of the base:

1. When the phone rings, press the TALK button on the handset. The LCD Display will show " TALK" and the base unit IN USE LED will light up.
2. Start your conversation.
3. To end your conversation, either press the TALK button or place the handset on the base unit.

Last Number Redial

A. AFTER HEARING A BUSY TONE WHEN PLACING A CALL

1. If you get a busy tone, press handset TALK button to hang up.
2. Press the handset TALK button again and listen for a dial tone.
3. Press the handset RE/PA/DEL button. This will automatically redial the last telephone number you called (up to 32 digits).
4. When finished with your call, press the TALK button or place the handset on the base unit.

B. WHEN THE HANDSET IS OFF THE BASE UNIT AND IN STANDBY MODE

1. Press the TALK button on the handset and listen for a dial tone.
2. Press the RE/PA/DEL button. This will automatically redial the last telephone number you called (up to 32 digits).
3. When finished with your call, press the TALK button or place the handset on the base unit.

SAVING IN THE PHONEBOOK

1. Press the SAVE/PHONE BOOK button.
2. Press the EDIT/FLASH button.
3. Use the TELEPHONE KEYPAD button(0-9) to enter the name, (see the "TELEPHONE KEYPAD CHARACTERS SETTING" section) you can store up to 15 characters.
4. Press the DN button once.
5. Enter the telephone number using the TELEPHONE KEYPAD button(0-9). You can store up to 16 digits.
6. Press the SAVE/PHONE BOOK button to save into memory
7. Press the SA/PHONE BOOK button to go back to standby mode.

NOTE: If there are no memory locations left in the phonebook, the unit will display " MEMORY FULL". To continue with memory programming, you must delete or edit existing speed dial numbers. If no active buttons are pressed for 20 seconds, the LCD Display will automatically return to STANDBY mode. It will not save a duplicate telephone

number or a name without the corresponding telephone number in the Phonebook.

A. **PREFERRED CALLS(VIP)**

You can assign a PREFERRED CALL which will generate a special ringer sound at start of the second ring to any welcome caller in the Phonebook.

1. Press the SAVE/PHONE BOOK button.
2. Press the UP OF DN button to find the one you need.
3. Press the MENU/SCAN button once. The LCD Display will show "VIP".
4. Press the SAVE/PHONE BOOK button to save the preferred call and go back to STANDBY mode.



VIP
JOHN SMITH
888-555-1212
#1 TOTAL20

B. **BLOCKED CALLS**

You can assign a BLOCKED CALL which will disable the ringer sound from the second ring to any caller in the Phonebook.

1. Press the SAVE/PHONE BOOK button.
2. Press the UP OF DN button to find the one you need.
3. Press the MENU/SCAN button twice. The LCD Display will show "REJ".
4. Press the SAVE/PHONE BOOK button to save the preferred call and go back to STANDBY mode.



REJ
JOHN SMITH
888-555-1212
#2 TOTAL20

TELEPHONE KEYPAD CHARACTERS

The TELEPHONE KEYPAD buttons(0-9) are used to enter the characters when entering names. Press the appropriate KEYPAD button to get the following characters.

KEYPAD BUTTON	CHARACTERS
1	Space & (. 1
2	A B C 2
3	D E F 3
4	G H 1 4
5	J K L 5
6	M N 0 6
7	P Q R S 7
8	T U V 8
9	W X Y Z 9
0	0

For example, If you want to enter the character "C", press the "2" KEYPAD button, the first character displayed will be "A". Press the "2" button again to display "B", and press again to display the letter "C". To enter the next character, press the appropriate button. If, however, the next character is on the same button as the previous character, you will first need to press the SHIFT RIGHT → button. Pressing the SHIFT RIGHT → button a second time will produce a space. If you want to change any character, you can go back to the incorrect character by pressing the SHIFT LEFT ← button. To delete the character inside the cursor "█", press the RE/PA/DEL button.

VIEWING THE PHONEBOOK

This Phonebook lets you scroll through the list to find the person you need for one touch dialing. You can store up to 20 names and telephone numbers in the Memory.

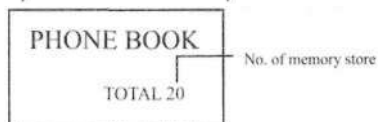

1. Press the SAVE/PHONE BOOK button.
2. Press the UP 01" UN button to find the one you need, press the SHIFT RIGHT "-"-button if the name or telephone number is more than 11 digits.



NOTE: To exit the Phonebook at anytime, Press the SAVE/PHONE BOOK button.

EDITING NAME AND NUMBER IN THE PHONEBOOK

1. Press the SAVE/PHONE BOOK button.
2. Press the UP or DN button to find the one you want to edit.
3. Press the EDIT/FLASH button to edit the name.



4. Press the SHIFT LEFT ← or RIGHT → button to move the cursor to the letter or number you want to change.
To erase, press the RE/PA/DEL Button
To add, use the TELEPHONE KEYPAD buttons(0-9).
5. Press the DN button to edit the number.
6. Press and hold the SHIFT LEFT ← or RIGHT → button to move the cursor to the number you want to change.
To erase, press the RE/PA/DEL button.
To add, use the TELEPHONE KEYPAD buttons(0-9).



7. Press the SAVE/PHONE BOOK button to confirm.

IMPORTANT: It is not advisable to save a telephone number without the corresponding name in the Phonebook. This will lead to improper displays on Private and Out of Area calls.

NOTE: When no active buttons are pressed for 20 seconds, the LCD Display will automatically return to STANDBY mode.

PLACING CALLS FROM THE PHONEBOOK

1. Press the SAVE/PHONE BOOK button.
2. Press the UP Or DN button to find the one you want to call.
3. Press the TALK, button to dial out the telephone number.
4. Start your conversation.
5. To end your conversation, either press the TALK button or place the handset on the base unit.

NOTE: Be sure to check that the line is not in use by another extension.

DELETING A STORED NUMBER

1. Press the SAVE/PHONE BOOK button.
2. Press the UP OF DN button to find the one you want to delete.
3. Press the RE/PA/DEL button. The unit will ask you to delete the selected telephone number and the LCD Display will show "ERASE ITEM?".

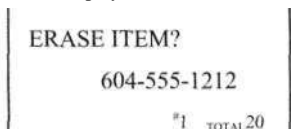

ERASE ITEM?

604-555-1212

☎ TOTAL 20

4. Press again the "RE/PA/DEL button to delete. The LCD Display will show "ERASED".
5. Press the SAVE/PHONE BOOK button to return to STANDBY mode.

MIXED MODE DIALING (Temporary Pulse to Tone Dialing)

1. If you only have pulse (rotary dialing) service in your area and want to access Tone services (Bank by Phone , etc.), ensure that the Tone/Pulse switch on the bottom of the base unit is set to the Pulse position.
2. Press the TONE(*) button once to switch from Pulse to Tone dialing temporarily. Pulse dialing mode resumes when the call is ended.

PAUSE FUNCTION

- In some cases, such as PABX or long distance service, a pause may be needed in the dialing sequence. Pressing the handset RE/PA/DEL button inserts the programmed time interval between dialed numbers.

FLASH FUNCTION

- Used to access custom calling features such as Call Waiting or Three-Way Calling provided by your local phone company. Flash can also be used to restore a dial tone to make a new call.

CHANNEL SELECTION(40 Channels)

- Your cordless telephone lets you select a channel from the 40 frequencies available to transmit signals between the base unit and handset. If the existing channel becomes noisy or starts having interference, you can either move closer to the base unit or press the MENU/SCAN button on the handset until a better reception is found.

OUT OF RANGE WARNING

- The handset and base unit communicate up to a certain maximum range. The distance can be affected by weather, power lines, or even other cordless telephone.
- If you are far away from the base unit, the handset beeps and "OUT RANGE" is shown on the LCD Display to warn you that the background noise level is too high for proper communication between the handset and the base unit.
- When you hear this sound and see the "OUT RANGE" display, you should move closer to the base unit. Otherwise, the call will automatically cut off after 20 seconds.

LOW BATTERY WARNING

- When the handset battery voltage level is low, the handset LCD Display shows "LOW BATTERY".
- Return the handset on the base cradle to charge.

PAGING FUNCTION

- If you have misplaced the handset or need to alert person nearby the handset, press the PAGE button on the base unit. Each press of this button will activate the handset to beep for 20 seconds and LCD Display shows "PAGING" while it is being paged by the base unit.

NOTE: Even if the handset is in RING OFF mode, the base unit can page the handset.

CALLER ID OPERATION

GETTING TO KNOW YOUR NEW PHONE

IMPORTANT: Subscription to Caller ID (CID)/Call Waiting ID services from your local phone company is required for using the Caller ID/Call Waiting ID features of the 36028. Your new 36028 telephone gives you the ultimate in cordless telephone sound quality with the luxury of Caller ID and Call Waiting ID. If this is your first cordless telephone, you will soon discover that your cordless is similar to regular telephones, except without the cord. If you have owned a cordless in the past, you will discover that the 36028 telephone is the most powerful and full-functioned Call Waiting ID cordless telephone on the market, some key features are:

- 40 name and number Caller ID/Call Waiting ID memory(Call List)
- 20 name and number programmable memory (Phonebook)
- Hearing - aid compatibility
- Automatic or manual selection of the clearest of 40 channels

Unlike regular telephones, your cordless telephone does not work during power failures. We do not recommend you to use a cordless telephone as the only phone in your residence

INTRODUCTION TO CALLER ID AND CALL WAITING ID

The 36028 Caller ID/Calling Waiting ID devices allow you to take advantage of the Caller identification delivery service offered by your local telephone company. For more information, you can refer to the following Question and Answer table:

QUESTIONS	ANSWERS
What is Caller ID?	Caller ID is a device that identifies the calling party before you answer a call. This device can be used to screen unwanted calls and eliminate harassment from annoying calls.
What is Caller Waiting ID?	Call Waiting ID is a device that can also identify the call waiting party before you answer a call.
How does Caller ID and Call Waiting ID work?	When used with Caller ID/Call Waiting service, the Caller ID/Call Waiting ID device displays the name(if available), and the telephone number (if available) of the person calling before you answer your telephone.
Who provides Caller ID service?	Your local telephone company. However, not all local telephone companies provide Caller ID service. Please call your local phone

	company to confirm that the service is available before you install the device.
How can I activate my Caller ID?	For you Caller ID unit to function, you must first arrange with your local telephone company to have Caller ID/Call Waiting ID service installed on you line. There is an extra charge added to your monthly telephone bill for this service. Before using this unit, please read this instruction manual carefully.

RECEIVING NEW CALL

- When you receive a new call, the call information is stored under CALLER ID List. The "NEW" segment of LCD Display and NEW CALL LED indicator will flash if there is new call(s).
- When you receive a call, the system displays the caller information sent by the telephone company, called a Call Record. The Call Record consists of the following information:
 - a. The caller's name(if available) **JOHN SMITH**
 - b. The caller's telephone number **555-555-1212**
 - c. The time and date of a call **10:00^{AM} 12/15**
 - d. A call record number **NEW *8**
- If there is no call records, the LCD display shows "NO CALLS"

VIEWING THE CALLER ID LIST

1. In standby mode, press CALLS button to enter Caller ID list. If there is new call(s), the new call(s) will be displayed at first. If the name or number is more than 11 characters, press the SHIFT RIGHT "**" button to view the rest of the display.

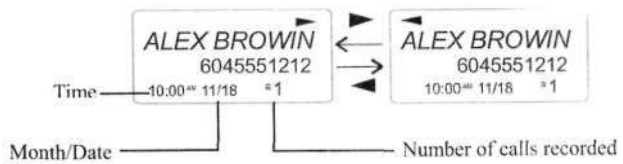

2. Press UP 01' DN button to scroll to the next call. The DN button will go through the calls from the last call received to the first. The LP button will allow you to view the calls from the first call received to the last.
3. Press CALLS button to finish.

NOTE: If no active buttons are pressed for 20 seconds, the LCD Display will automatically return to STANDBY mode.

CALLER ID DISPLAY

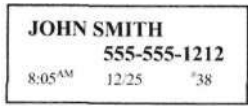

LCD Display shows name and number, time and date of the call.

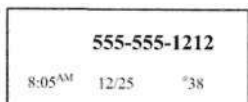

LCD Display shows number-only service.

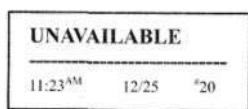

"UNAVAILABLE" will be displayed when Caller ID information is not available. This call was made from a telephone company that does not offer Caller ID services(including international calls).

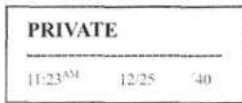

"PRIVATE" will be shown when a call is received from a blocked number. For privacy reasons, some states allow callers the option to prevent their telephone data from being displayed on the other party's Caller ID display.

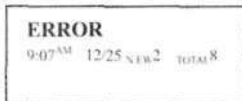

Display shows when the Caller ID information was received incorrectly or only part of the data was received. NOTE: When an error is received, none of the date from This call is saved in memory.

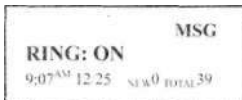

Display shows when a voice mail message has been received and is stored by message waiting service provided by the phone company.

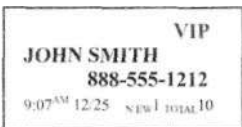

Display shows when the incoming call is a priority call.

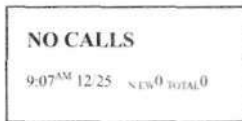

This is displayed when CALLS button is pressed and there is no Caller ID date stored.

NOTE: If a call is received from the same number more than once since the records were last viewed, no new entry is made, but the repeat call icon *RPT" and the number of repeat calls is displayed.

CALL WAITING

When you subscribe to Call Waiting service from your local telephone Company, this telephone will display the name and number of the second caller while you are having a conversation.

1. When a second call comes in while you are having a conversation, you will hear a notification tone from the handset and volume is momentarily muted. The LCD Display will automatically shows the name and number of the second caller.
2. Press the EDIT/FLASH button to answer the second caller. The first caller's name and number will be displayed.
3. When you have finished, press the EDIT/FLASH button to continue with your conversation with the first caller.

JIM CARRY

ALEX BROWN

800-2-10-8950

800-2-10-8950

2'NDCAI.I.KR

1'ST'AI I FR

MESSAGE WAITING

If you have subscribed to Voice Mail message service and if you have requested Visual Message Indication from your local telephone company, the MSG WTG /NEW CALL LED indicator will blink and the LCD Display will show "MSG" when there is voice message(s) for you from your telephone company. To remove the MESSAGE WAITING indicator, see the "Message Waiting Setting" section.

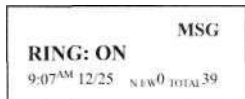

PLACING A CALL FROM THE CALLER LIST

- i Press the CALLS button.
2. Press the UP OF **DN** button to select the call record you wish to call back.
3. If the number displayed is not correct(needng 7,10,11 digits), press the OPTION button to select call number.

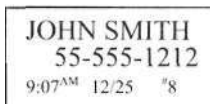

Press OPTION button



Press OPTION button

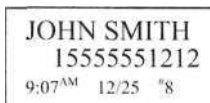

4. Press TALK button to dial out or press CALLS button to cancel dialing.
5. To end you conversation, either press the TALK button or place the handset on the base unit.

SAVING THE NAME AND NUMBER FROM THE CALLER LIST INTO PHONE BOOK

1. Press the CALLS button.
2. Press the UP Or **DN** button to scroll to the call record you wish to store into the phonebook.
3. Press SAVE/PHONE BOOK button. The LCD Display shows "SAVE".
4. Press CALLS button to return to standby mode.

SELECTIVE DELETING IN THE CALLER LIST

1. Press the CALLS button
2. Press the **UP** or **DN** button to scroll to the call record you wish to delete.
- 1 Press RE/PA/DEL button. The LCD Display will show "ERASE ITEM?"

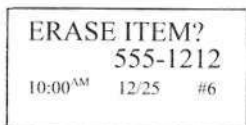

4. To delete the selected call record, press RE/PA/DEL button.

5. Press the CALLS button to return to STANDBY mode.

DELETING ALL RECORDS IN THE CALLER LIST

1. Press the CALLS button.
2. Press and **hold** RE/PA/DEL button. The LCD Display will show " ERASE ALL?"
3. To delete all Caller ID records, press RE/PA/DEL button. The LCD Display will show "ERASE ALL" and return to standby mode.

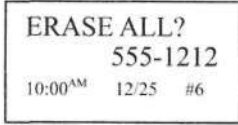

PROGRAMS OPERATION

This unit contains the following special Programs:

- | | |
|----------------------|------------------------|
| A. RING ON/OFF | G. MSG WAITING |
| B. LANGUAGE | H. AUTO ANSWER ON/OFF |
| C. FIRST RING ON/OFF | I. PRIVATE RING ON/OFF |
| D. TIME SET | J. UNAVAIL RING ON/OFF |
| E. AREA CODE | K. IT SET |
| F. CONTRAST | |

A. RING ON/OFF

To turn on or off the ringing sound.

1. Press and **hold** the MENU/SCAN button.
2. Press the TELEPHONE KEYPAD #1 button.
3. Press the EDIT/FLASH button.
4. Press the UP or DN button to select ON or OFF. RING ON is the preset mode.
5. Press the SAVE/PHONE BOOK button to save the setting.
6. Press the MENU/SCAN button to go back to standby mode.

RING:ON
*01 TOTAL11

B. LANGUAGE

This telephone offers English, Spanish and French languages for your convenience.

1. Press and **hold** the MENU/SCAN button.
2. Press the TELEPHONE KEYPAD #2 button.
3. Press the EDIT/FLASH button.
4. Press the UP OF DN button to select the language you desire. English is the preset language.
5. Press the SAVE/PHONE BOOK button to save the setting.
6. Press the MENU/SCAN button to go back to standby mode.

ENGLISH
*02 TOTAL11

C. FIREST RING ON /OFF

You can turn off the first ring of the telephone so that it does not ring until caller ID information has been displayed.

1. Press and **hold** the MENU/SCAN button.
2. Press the TELEPHON KEYPAD #3 button.
3. Press the EDIT/FLASH button.
4. Press the UP or DN button to select the ON or OFF. FIRST RING ON is the preset mode.
5. Press the SAVE/PHONE BOOK button to save the setting.
6. Press the MENU/SCAN button to go back to standby mode.

FIRST RING
On
*03 TOTAL11

TIME SET

Set the date and time.

TIME SET

Press and hold the MENU/SCAN button.

Press the TELEPHONE KEYPAD #4 button. 10:03 AM 12/25 '04 TOTAL 11

Press the EDIT/FLASH button.

Use the TELEPHONE KEYPAD button to enter the month, date, hour and minute. The cursor moves automatically after entering each item.

Press the TELEPHONE KEYPAD #1 for AM setting, or

Press the TELEPHONE KEYPAD #2 for PM setting.

5. When the final setting is programmed, the time and date are automatically saved.
6. Press the MENU/SCAN button to go back to STANDBY mode.

NOTE: The date and time will automatically set, if you have subscribed to the Caller ID service from your local telephone company.

E. AREA CODE

AREA CODE

1. Press and **hold** the MENU/SCAN button.
2. Press the TELEPHONE KEYPAD #5 button. '05 TOTAL 11
3. Press the EDIT/FLASH button.
4. Use the TELEPHONE KEYPAD buttons to enter the three digit area code.
5. Press the SAVE/PHONE BOOK button to save the setting.
6. Press the MENU/SCAN button to go back to standby mode.

F. CONTRAST

This unit enables you to select 3 brightness levels for the Large LCD Display.

1. Press and **hold** the MENU/SCAN button.
2. Press the TELEPHONE KEYPAD #6 button.
3. Press the EDIT/FLASH button.
Press the UP or DN button to adjust the brightness of the display. Level 2 is the preset brightness.
5. Press the SAVE/PHONE BOOK button to save the setting.
6. Press the MENU/SCAN button to go back to standby mode.

CONTRAST

2

'06 TOTAL 11

MSG WAITING (Message Waiting)

To turn off the Message Waiting LCD/LED indicator.

MSG WAITING

delete

'07 TOTAL 11

1. Press and **hold** the MENU/SCAN button.
2. Press the TELEPHONE KEYPAD #7 button.
3. Press the EDIT/FLASH button.
4. Press the SAVE/PHONE BOOK button, the Message Waiting LCD/LED indicator turns off.
5. Press the MENU/SCAN button to go back to STANDBY mode.

IMPORTANT: Message Waiting LCD/LED indicator will automatically turn on, if you have subscribed to Voice Mail message service and if you have Visual Message indication from your local telephone company.

H. AUTO ANSWER ON/OFF

Turn on or off the auto answer feature. When in on mode, the phone will automatically answer an incoming call if the handset is lifted from the base unit.

AUTO ANSWER

On

'08 TOTAL 11

1. Press and **hold** the MENU/SCAN button.
2. Press the TELEPHONE KEYPAD #8 button.
3. Press the EDIT/FLASH button.
4. Press the UP or DN button to select ON or OFF. AUTO ANSWER ON is the preset mode.

5. Press the SAVE/PHONE BOOK button to save the setting.
6. Press the MENU/SCAN button to go back to STANDBY mode.

PRIVATE RING ON/OFF

Turn on or off ring or all calls where the caller has blocked their caller ID.

1. Press and **hold** the MENU/SCAN button.
2. Press the #9 button twice.
3. Press the EDIT/FLASH button.
4. Press the UP Or DN button to select ON or OFF.

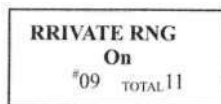

PRIVATE RING ON is the preset mode.

5. Press the SAVE/PHONE BOOK, button to save the setting.
6. Press the MENU/SCAN button to go back to standby mode.

NOTE: The phone will ring once when set to OFF mode unless first ring is set to OFF mode.

UNAVAILABLE RING ON/OFF

Turn on or off ring or all calls where the caller has blocked their caller ID.

1. Press and **hold** the MENU/SCAN button.
2. Press the #0 button once.
3. Press the EDIT/FLASH button.
4. Press the UP Or DN button to select ON or OFF.

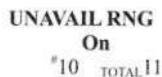

UNAVAIL RING ON is the preset mode.

5. Press the SAVE/PHONE BOOK button to save the setting.
6. Press the MENU/SCAN button to go back to standby mode.

NOTE: The phone will ring once when set to OFF mode unless first ring is set to OFF mode.

- A. **ID SET** (for Handset 1 and Handset 2) [NOTE: ID SET had been preset at the factory. The user doesn't need to do the ID SET. If the handset can not be linked up with base unit properly, please reset the ID SET. (Reset ID SET: The user must delete the base ID, and then do the ID SET.)]

1. Press and **hold** the SCAN/MENU button.
2. Press the * button once.
3. Press the SAVE/PHONE BOOK button.

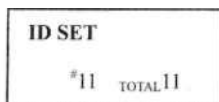

The LCD will indicate PRESS PAGE.

4. Press and hold the page button until beeping on the handset, and then the handset will indicate ID success.

DELETE BASE ID:

1. Press and hold the page button about 4 seconds, and then the base IN USE LED will light up .
2. Press and hold the page button about 2 seconds, and then the base IN USE LED will flash.
3. Press again the page button , and then the base IN USE LED will turn off.

ANSWERING MACHINE OPERATION

The 36028 features a sophisticated Digital Answering System. Incoming Messages (ICMs), Outgoing Message (OGM) and Memo messages are stored electronically into digital memory. Messages are accessed instantly and arranged compactly in this memory. The 36028 can store 15 minutes of message (ICMs, OGM and Memos Combined).

NOTE: The maximum incoming Message (ICM) recording time is 1 minutes. The minimum incoming Message (ICM) recording time is 3 seconds.

VOICE MENU SYSTEM

A sophisticated Voice Menu System has been designed and pre-programmed into the 36028. This system will verbally guide you through key operational procedures.

TIME/DAY STAMP

ICMs and Memo messages are automatically voice-stamped with the current time and day.

NOTE: After power failure, the time/day stamp will be lost. In this case, the time will be incorrect. Please refer to the INITIAL SETUP section on how to set the system time and day.

SETTING ANSWER ON/OFF

The unit defaults to Answer ON automatically after power up.

A. TO TURN ANSWER MODE OFF

1. In standby mode, press the ANS. ON/OFF button on the base unit until you hear "Answering machine is off".
2. The 36028 will announce "Answering machine is off".

NOTE: If the Answering Mode is OFF, the 36028 will answer after the 8th ring. The 36028 will say "Hello! I am unable to answer your call right now. Please call again thanks!"

B. TO TURN ANSWER MODE ON

1. In standby mode, press the ANS. ON/OFF button until you hear "Answering machine is on".

NOTE: The 36028 will answer after ringing.

SETTING THE RINGS SWITCH(TS/4R/2R)

The number of rings before the answering system answers a call be selected by setting the RINGS switch on the base unit to :

TS - Toll Saver

4 - Four rings

2 - Two rings

Toll Saver lets you avoid unnecessary toll charges when calling long distance to remotely retrieve your messages.

The 36028 can be set to answer the first call on the 4th ring, and all subsequent calls on the 2nd ring by setting the RINGS switch on the Toll Saver (TS) position. If your 36028 fails to answer on the 2nd ring, then you know that you do not have any new incoming Message(s)(ICM). You can hang up before the unit answers and save the cost of the call.

SETTING TIME/DAY

1. Press "TIME SET" button. You will hear current Time/Day setting the time and day.
2. Press and hold "TIME SET" button for about 3 seconds. You will hear "Sunday".
3. Press "SKIP ►►" or "REPEAT ◀◀" button (on the base) until the correct day is announced.
4. Press "TIME SET" button to confirm and then set the hours. You will hear "12AM" as the "12AM" is displayed in message counter.
5. Press "SKIP ►►" button to advance or "REPEAT ◀◀" button to reverse the hour show in the display.
6. Press "TIME SET" button to confirm and then set the minutes, you will hear "00" as the "00" is displayed in message counter.
7. Press "SKIP ►►" button to increment or "REPEAT ◀◀" button to decrement the minute in the display.
8. Press "TIME SET" button to confirm. The new day and time will announced.

SETTING CODE

1. Press CODE button on the base. The base unit LED will show "1, 5, 9".
2. Then you will hear the "one".
3. Press Skip ►► or Repeat ◀◀ button (on the base) to select the first digit you desired.
4. Press the CODE button to confirm.
5. Press Skip ►► or Repeat ◀◀ button to select the second digit you desired.
6. Press the CODE button to confirm.
7. Press Skip ►► or Repeat ◀◀ button to select the third digit you desired.
8. Press the CODE button to confirm.

You will hear the newly programmed 3-digit security code.

NOTE: The factory preset password is "159".

OUTGOING MESSAGE (OGM)

This is the announcement callers will hear when 36028 answers a call. The 36028 also has a default OGM (factory preset) which is active when there is no OGM present.

Default OGM: "Please record your message after the beep."

RECORDING THE OUTGOING MESSAGE (OGM) (The maximum recording time is 59 seconds.

The minimum recording time is 3 seconds)

1. In standby mode, Press the OGM button.
2. Press and hold the OGM button.
3. Record your greeting after you hear a beep tone.
4. Press the OGM button after you finish recording your greeting. Your recorded greeting will be played.

CHECKING THE OUTGOING MESSAGE (OGM)

1. In standby mode, press the OGM button on the base unit to hear your previously recorded OGM.
2. You can stop OGM playback anytime during playback by pressing the PLAY/STOP button.

RECORDING A MEMO

Memo message(s) is recorded on the base unit. The maximum recording time is 1 minutes. The minimum recording time is 3 seconds.

1. In standby mode, Press the MEMO button.
2. Press and hold the MEMO button.
3. Record your greeting after you hear a beep tone.
4. Press the PLAY/STOP button after you finish recording your greeting.

PLAYING BACK MESSAGE

A. PLAYING MESSAGES

In standby mode, press the PLAY/STOP button on the base unit. The 36028 will announce "You have (number)(Memo) message." And begins playing the first message to the end. It will announce the message number before each message.

B. SKIPPING MESSAGES

Press the SKIP ►► button on the base unit during message playback to skip forward to the next message.

C. PREVIOUS MESSAGES

Press REPEAT ◀◀ button once on the base unit during message playback to skip backward one message.

D. STOP MESSAGE PLAYBACK

Press the PLAY/STOP button to stop message playback.

ERASING MESSAGES

A. SELECTIVE ERASING

1. Press the ERASE button on the base unit during message playback.
2. And then start the next message.

B. ERASING ALL ICM AND MEMO

1. In standby mode, press and hold the FRASF. button for about 2 seconds.

C. ERASING OGM

1. During OGM playback, press ERASE button.

MEMORY FULL DETECTION

The memory full condition occurs:

If 15 minutes of recording time is reached, or

If 59 message (i.e. Memo, OGM, ICM) have been recorded.

If there is an incoming call, the unit will answer at the 10* ring and announce "Memory full". You can erase any or all the messages remotely after listening to them.

NOTE: Sometimes you may fail to escape from memory full condition when erasing a short message. In this case, you must erase more messages (at least 1 minute message).

CALL SCREENING

You can listen to the caller leave their ICM and decide if you want to answer the call.

VOX (VOICE ACTIVATED) DETECTION

During OGM, ICM or Memo recording. The 36028 uses VOX (voice activation) to conserve message storage space. The conditions for the 36028 terminating a recording are:

Continuous silence for seven seconds.

Seven seconds after the caller hangs up.

CALLING THE 36028 FROM A TONE PHONE

NOTE: The factory preset password for remote operation is "159".

1. Call the 36028 from a tone dialing phone.
2. While the OGM is playing, enter the "*" to skip OGM play. A long beep tone will be heard. Then enter your 3 digits password.
3. After a successful password entry, the Remote Operation function is on.

Once you have activated the Remote Operation function through a tone dialing phone to call the 36028. The 36028 will announce the total number of new message(s) in Message (MSG) box.

According to Voice indication. The following table shows the Voice Help Menu:

Main menu announcement	Key press	Action
Play memos	3	Plays memos only
Play messages	4	Plays all messages
Play new messages	5	Plays only new messages
Delete all messages	*4	Deletes all messages
To stop function	7	Stop current function
To play the message/Played menu	9	To hear message menu; See the table below

The following table lists announcements made after you have pressed 9:

Message main menu	Key	Action
Repeat message	3	Repeats the current message
To skip message	5	Skips forward to the next message
Delete message	6	Deletes current message
To stop function	7	Stops current function

During message or memo playback	Key press
Replay previous message	33
Pause message	4
Change OGM1	*1
Record new MEMO	*2
Change security code	*3
Switch answerphone off	*5
Delete current message	6

Key(s)	Function
*	Skip OGM play
1	PlayOGMI
2	Room Monitor
#	End remote control operation

65,536 Combination Security Coding

The cordless telephone have a digital coding security system to prevent unauthorized use of your telephone line by other cordless phones nearby. The cordless telephone have 65,536 possible security code combinations. Each combination of the code is randomly generated every time the handset is picked up.

Resetting Security Code and Channel

Communication between the handset and the base unit may not be possible in any of the following situations:

1. After a power failure.
2. After relocating the base unit by disconnecting the AC adapter..
3. After replacing the handset battery.
4. The handset goes out of range from the base **unit**.

To reset, place the handset on the cradle of the base unit for five seconds.

IMPROVING CORDLESS RECEPTION

Follow these guidelines to improve cordless sound quality:

- Select an area to install the unit where it is closest to the center of your home or office. This will improve the operating range of the unit.
- Keep the base unit away from electrical equipment. Radio Frequency Interference (RFI) is sometimes generated by these appliances, which can cause a degradation in cordless reception.
- Keep the handset batteries charged as much as possible. Weak handset batteries can limit the range of cordless operation.

MAXIMIZING BATTERY LIFE

Repeated use or recharge of Ni-Cd batteries without periodic full discharge results in reduced useable charge time. When you notice the useable charge duration decreasing, fully discharge the Ni-Cd battery and recharge as described:

DISCHARGING

1. Unplug the telephone line cord from the 36028.
2. Make sure that the adapter is connected.
3. Lift the handset out of the base cradle.
4. Press the TALK button of the handset and start discharging.

Once the Symbol Low Battery appears on LCD Display, it means that the battery level is low. Let it fully discharge for 12 hours. Once the Ni-Cd battery is fully discharged, you may now charge the battery to its full capacity.

CHARGING

1. Make sure the adapter and telephone line cord are connected to the 36028.
2. Place the handset on the base cradle. The CHARGE LED indicator of the base unit will light steadily.
3. Leave the handset charging on the base for 14 hours continuously to get a maximum charge.
4. The 36028 is now ready for regular use. Discharge and charge the Ni-Cd battery again once you notice a decrease in the useable charge time.

MAINTENANCE

1. Your phone should be situated away from heat sources such as radiators, heaters, stoves or any other appliance that produces heat.
2. Use a slightly damp cloth to clean the plastic cabinet. A mild soap will help to remove grease or oil. Never use polish, solvents, abrasives or strong detergents since these can damage the finish.

TECHNICAL INFORMATION

This cordless phone uses radio frequencies to allow mobility. There are certain difficulties in using radio frequencies with a cordless telephone. While these are normal, the following could affect the operation of your system.

NOISE: Electric pulse noise is present in most homes at one time or another. This noise is most intense during electrical storms. Certain kinds of electric equipment such as light dimmers, fluorescent bulbs, motors, and fans also generate noise pulses. Because radio frequencies are susceptible to these noise pulses, you may occasionally hear them in your handset. Generally, they are minor annoyances and should not be interpreted as defects in your system.

RANGE: Because radio frequencies are used, location of the base unit can affect operating range. Try several locations in your home or business and pick the one that gives you the clearest signal.

INTERFERENCE: Some electronic devices operate in and/or generate interference near the operating frequencies of your cordless telephone. While several protection circuits are used to prevent unwanted signals, there may be periods when these unwanted signals cause interference. If interference occurs frequently, it can be minimized or eliminated by lowering the height of your base antenna or by relocating the base unit. You can check for interference before selecting the final base unit location by plugging in the phone.

TROUBLESHOOTING

A. TELEPHONE UNIT TROUBLESHOOTING TABLE

SYMPTOM	SOLUTION
No dial tone	<ul style="list-style-type: none">• Check the telephone line cord connectors at both ends that they are pushed in firmly until they click.• If you had a power failure or had unplugged the base unit, replace the handset on the base unit for two to five seconds to reset the system.
Does not ring	<ul style="list-style-type: none">• Check the RING ON/OFF mode on the handset. Set to RING ON mode to enable the handset ringer.• Check the telephone line cord connectors at both ends that they are pushed in firmly until they click.• You may have exceeded the Ringer Equivalence Number(REN) limit of how many phones can be connected to the same line. The REN total of all devices(printed on the bottom label of each unit)should not exceed five(5). Disconnect the appropriate units to lower the REN total.
No power on the handset unit	<ul style="list-style-type: none">• Check the Ni-Cd battery pack for proper connection inside the battery compartment on the handset.• The handset rechargeable Ni-Cd pack may need charging.
Does not charge	<ul style="list-style-type: none">• Check the Ni-Cd battery pack for proper connection inside the battery compartment on the handset.• Made sure the charging contacts on both the base unit and the handset are in contact during charging.• The charging contacts and terminals may need cleaning with an alcohol-dampened swab.
Range is limited	<ul style="list-style-type: none">• Move the base unit so that it is centrally located in your residence or office and make sure that the base unit is not located near appliances.• The handset Ni-Cd battery may be weak. Recharge the Ni-Cd battery.• Refer to the section " Improving Cordless Reception".
Calls received flutters or fades	<ul style="list-style-type: none">• The handset rechargeable Ni-Cd battery pack may need charging.• Choose an alternate channel using the MENU/SCAN button on the handset.
Interference on reception	<ul style="list-style-type: none">• Refer to the section "Improving Cordless Reception".
Excessive static	<ul style="list-style-type: none">• Refer to the section "Improving Cordless Reception".

B. CALLER ID SYSTEM TROUBLESHOOTING TABLE

SYMPTOM	SOLUTION
The Caller ID panel is blank	<ul style="list-style-type: none">• Check the power connection.• Check the telephone line cord connections.• Check the batteries for proper installation.
The Caller ID does not show the caller's name and/or phone number	<ul style="list-style-type: none">• The Caller ID unit will not function until you have Caller ID service provided by your local phone company. Call your local phone company to have Caller ID installed on your telephone line.• If you pick up the phone before the second ring, the caller information will not be correctly received. If you have telephone answering device (TAD) connected with the unit, set the TAD to answer after two rings or more.• If it is a blocked call or an out-of-area call, the caller's name and/or phone number will not appear on the display.• If only the caller's phone number appears on the display, it may be Single Data Message Format (SDMF) call, as opposed to a Multiple Data Message Format (MDMF) call. Please call your local phone company to see which service you have.
Random characters and/or "NO DATA" appear on the LCD display	<ul style="list-style-type: none">• On rare occasions, the Caller ID information sent by the telephone company may have an error in the transmission. This is not the fault of your Caller ID unit. It can only capture and store the data that was received.
Cannot get call Waiting identification on the LCD panel	<ul style="list-style-type: none">• Subscription to Caller ID Call Waiting (CIDCW) is required from your local phone company for the CIDCW function to operate properly. Call your local phone company for details.

AC ADAPTOR: USE ONLY WITH CLASS 2 POWER SOURCE, OUTPUT 9VDC, 500mA for base unit and 200mA for charger .

! THIS SYMBOL IS INTENDED TO ALERT THE USER OF THE PRESENCE OF IMPORTANT OPERATING AND MAINTENANCE (SERVICING) INSTRUCTIONS IN THE OWNER'S MANUAL.