

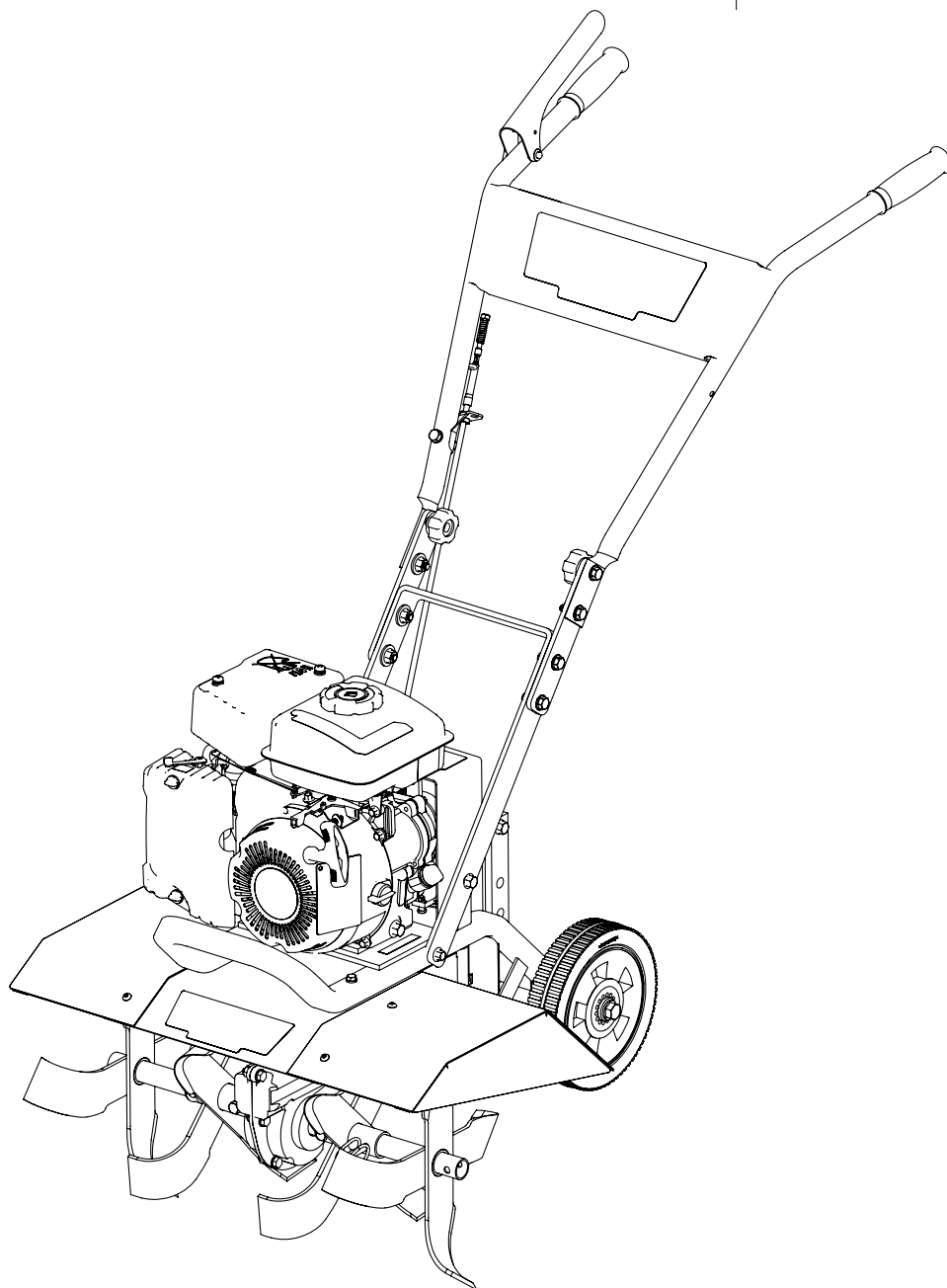

Operator's Manual
Original Operating Instructions
VECTOR™
Compact Tiller



Includes Model: 26750

INTRODUCTION

Congratulations on your investment in quality. Thank you for purchasing the VECTOR™ Compact Tiller from Earthquake®. We have worked to ensure that this tiller meets the highest standards for usability and durability. With proper care, your tiller will provide many years of service.

Please read this entire manual before installation and use. Earthquake® reserves the right to change, alter or improve the product and this document at any time without prior notice.

CONTENTS

Introduction 2
 Warnings and Safety Precautions..... 3-7
 Features 8
 Specifications..... 8
 Unpacking and Assembly 9-10
 Operation 11-13
 Maintenance and Storage..... 13-15
 Troubleshooting and Repair..... 16
 Parts Breakdown..... 17-22
 Warranty 23

FEDERAL EMISSION INFORMATION

Earthquake® warrants to the retail purchaser, that this compact tiller was designed, built and equipped to conform at the time of initial sale to all applicable regulations of the U.S. Environmental Protection Agency (EPA).

REGISTRATION AND SERVICE

Record the engine model number and serial number in the space provided for easy reference when ordering parts or requesting technical support. Excluding emissions-related warranty items, the warranty is valid only if the completed registration is received by Ardisam within 30 days of purchase. **(SEE WARRANTY SECTION FOR MORE INFORMATION.)** You can register your warranty online by visiting www.getearthquake.com, or by mailing it to: Ardisam, 1160 Eighth Avenue, Cumberland, WI 54829. If you do not have a computer, call our customer service department at (800) 345-6007 Mondays through Fridays from 8 a.m. to 5 p.m. CST.

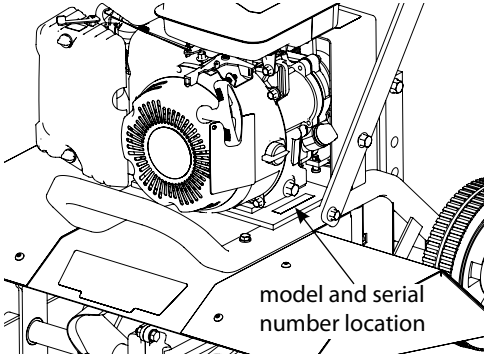

OWNERSHIP RECORDS		
Owner's Name:		
Owner's Address:		
City:	State/Province:	Zip Code/Postal Code:
Model Number:	Serial Number:	
Date of Purchase:		
Notes:		

This manual may contain information for several models. Read and keep this manual for future reference. This manual contains important information on SAFETY, ASSEMBLY, OPERATION, AND MAINTENANCE. The owner must be certain that all the product information is included with the unit. This information includes the MANUAL, the REPLACEMENT PARTS and the WARRANTIES. This information must be included to make sure state laws and other laws are followed. This manual should remain with the engine even if it is resold.

WARNINGS AND SAFETY PRECAUTIONS OPERATOR'S RESPONSIBILITY

Accurate assembly and safe and effective use of the machine is the operator's responsibility.

- Read and follow all safety instructions.
- Carefully follow all assembly instructions.
- Maintain the machine according to directions and schedule included in this Earthquake® operator's manual.
- Ensure that anyone who uses the machine is familiar with all controls and safety precautions.

SPECIAL SAFETY MESSAGES

Your manual contains special messages to bring attention to potential safety concerns, machine damage as well as helpful operating and servicing information. Please read all the information carefully to avoid injury and machine damage.

NOTE: General information is given throughout the manual that may help the operator in the operation or service of the machine.



This symbol points out important safety instructions which if not followed could endanger your personal safety. Read and follow all instructions in this manual before attempting to operate this equipment.

BEFORE OPERATING ENGINE:

Please read this section carefully. Read entire operating and maintenance instructions AND the instructions in the engine manual that accompanies this product (if applicable). Failure to follow instructions could result in serious injury or death. Operate the machine according to the safety instructions outlined here and inserted throughout the text. Anyone who uses this machine must read the instructions and be familiar with the controls.

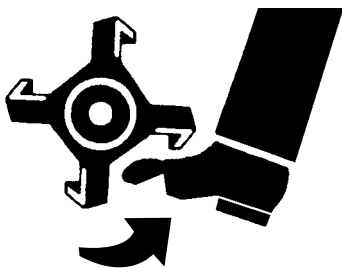

WARNING

WARNING INDICATES A HAZARD WHICH, IF NOT AVOIDED, COULD RESULT IN DEATH OR SERIOUS INJURY AND/OR PROPERTY DAMAGE.



CAUTION

CAUTION INDICATES YOU CAN BE HURT OR YOUR EQUIPMENT DAMAGED IF THE SAFETY INSTRUCTIONS THAT FOLLOW THIS SIGNAL WORD ARE NOT OBEYED.



IMPORTANT

INDICATES HELPFUL INFORMATION FOR PROPER ASSEMBLY, OPERATION, OR MAINTENANCE OF YOUR EQUIPMENT.



WARNING

CALIFORNIA PROPOSITION 65 WARNING

ENGINE EXHAUST FROM THIS PRODUCT CONTAINS CHEMICALS KNOWN TO THE STATE OF CALIFORNIA TO CAUSE CANCER, BIRTH DEFECTS, OR OTHER REPRODUCTIVE HARM.



WARNING

YOU MUST READ, UNDERSTAND AND COMPLY WITH ALL SAFETY AND OPERATING INSTRUCTIONS IN THIS MANUAL BEFORE ATTEMPTING TO SETUP AND OPERATE YOUR MACHINE.

FAILURE TO COMPLY WITH ALL SAFETY AND OPERATING INSTRUCTIONS CAN RESULT IN LOSS OF MACHINE CONTROL, SERIOUS PERSONAL INJURY TO YOU AND/OR BYSTANDERS, AND RISK OF EQUIPMENT AND PROPERTY DAMAGE. THE TRIANGLE IN THE TEXT SIGNIFIES IMPORTANT CAUTIONS OR WARNINGS WHICH MUST BE FOLLOWED.

Intended Use / Foreseeable Misuse

IMPORTANT: This is a motorized rotary tiller that works the soil by means of rotating tines. It is pedestrian-controlled, but not self-propelled, with a gasoline-fueled internal combustion engine to power the tines. It shall not be used for any other purpose.

GENERAL SAFETY RULES

- Read, understand, and follow all instructions on the machine and in the manual(s). Be thoroughly familiar with the controls and the proper use of the machine before starting.
- Use this equipment for its intended purpose only.
- Familiarize yourself with all of the safety and operating decals on this equipment and on any of its attachments or accessories.
- Do not put hands or feet near or under rotating parts.
- Only allow responsible individuals who are familiar with the instructions to operate the machine. Do not allow children to operate this machine. Do not allow adults to operate the machine without proper instruction.
- Thoroughly inspect the area where the machine is to be used and remove all foreign objects. Your equipment can propel small objects at high speed causing personal injury or property damage. Stay away from breakable objects, such as house windows, automobile, greenhouses, etc.
- Never wear sandals, sneakers, or open shoes, and never operate the machine with bare feet.
- Do not wear loose clothing or jewelry. They can get caught in moving parts. Always keep hands, feet, hair and loose clothing away from any moving parts on engine and machine.
- Always wear safety goggles or safety glasses with side shields when operating the machine to protect your eyes from foreign objects which can be thrown from the unit. Always wear a protective hearing device.
- Always wear work gloves and sturdy footwear. Wear footwear that will improve footing on slippery surfaces.
- Do not operate the machine without proper guards, covers, hoods or other safety protective devices in place.
- See manufacturer's instructions for proper operation and installation of accessories. Only use accessories approved by the manufacturer.
- Operate only in daylight or good artificial light.
- Do not operate product when fatigued or under the influence of alcohol, drugs or other medication which can cause drowsiness or affect your ability to operate this machine safely.
- Never operate machine in wet grass. Always be sure of your footing; keep a firm hold on the handle and walk; never run.
- Watch for traffic when operating near, or when crossing roads.
- If the equipment should start to vibrate abnormally, stop the engine (motor), disconnect the spark plug wire and prevent it from touching the spark plug. Check immediately for cause. Vibration is generally a warning of trouble. If the noise or vibrations of the machine increase, stop immediately and

IMPORTANT

THE RIGHT AND LEFT SIDES OF YOUR ROTOTILLER ARE DETERMINED FROM THE OPERATING POSITION AS YOU FACE THE DIRECTION OF FORWARD TRAVEL.

ENGINE IS SHIPPED FROM FACTORY WITHOUT OIL. YOU MUST ADD ENGINE OIL BEFORE STARTING ENGINE.

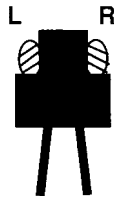

perform an inspection.

- Never leave the machine unattended when the engine is running. Remove the wire from the spark plug.
- Regularly inspect the machine. Make sure parts are not bent, damaged or loose.
- Temperature of muffler and nearby areas may exceed 150° F (65° C). Allow muffler and engine areas to cool before touching. Never pick up or carry the machine while the engine is running.
- Prolonged exposure to noise and vibration from gasoline engine-powered equipment should be avoided. Take intermittent breaks and/or wear ear protection from engine noise as well as heavy work gloves to reduce vibration in the hands.
- Keep all screws, nuts and bolts tight.
- Do not transport the machine from one place to another with the engine running.
- When moving the packaged machine, always do so with a partner.
- Check local regulations for age restrictions on use of this machine.

PRODUCT-SPECIFIC SAFETY RULES

- Do not till above underground utilities, including water lines, gas lines, electric cables, or pipes. Do not operate the tiller in soil with large rocks and foreign objects which can damage the equipment.
- After striking a foreign object, stop the engine. Remove the wire from the spark plug. Inspect the tiller for damage. If damaged, repair before starting and operating the tiller.
- The tines of the tiller should not rotate when the engine is idling. If they do rotate when engine is idling, contact Earthquake® customer service for instructions.
- If an object becomes lodged in the tines, turn engine off, remove the wire from the spark plug and secure, allow to cool before attempting to remove the foreign object.
- The tines can be very sharp. Use extreme caution when tilling or replacing the tines.
- Tines rotate when the tiller is engaged; tines rotate when the drive safety control lever is pulled down. Releasing the drive

safety control lever to the neutral position stops the tines.

- Do not overload the machine capacity by attempting to till too deep at too fast of a rate.
- Be careful when tilling in hard ground. The tines may catch in the ground and propel the tiller forward. If this occurs, let go of the handlebars and do not restrain the machine.
- Take all possible precautions when leaving the machine unattended. Disengage all control levers, stop the engine, wait for all moving parts to stop, and make certain guards and shields are in place.

ENGINE SAFETY PRECAUTIONS

Warning Carbon Monoxide Poisoning

Engines give off carbon monoxide, an odorless, colorless, poison gas. Carbon monoxide may be present even if you do not smell or see any engine exhaust. Breathing carbon monoxide can cause nausea, fainting or death, in addition to drowsiness, dizziness and confusion. If you experience any of these symptoms, seek fresh air and medical attention immediately.

If your product comes with a separate engine manual, be sure to read and follow all safety and warning precautions outlined there, in addition to any in this manual.

Preventing Carbon Monoxide Poisoning

- Always start and run engine outdoors. Do not start or run engine in an enclosed area, even if doors or windows are open.
- Never try to ventilate engine exhaust indoors. Carbon monoxide can reach dangerous levels very quickly.
- Never run engine outdoors where exhaust fumes may be pulled into a building.
- Never run engine outdoors in a poorly ventilated area where the exhaust fumes may be trapped and not easily taken away. (Examples include: in a large hole or areas where hills surround your working area.)
- Never run engine in an enclosed or partially enclosed area. (Examples include: buildings that are enclosed on one or more sides, under tents, car ports or basements.)
- Always run the engine with the exhaust and muffler pointed in the direction away from the operator.
- Never point the exhaust muffler towards anyone. People should always be many feet away from the operation of the engine and its attachments.
- Do not change the engine governor settings or over-speed the engine.

WARNING

ENGINES GIVE OFF CARBON MONOXIDE, AN ODORLESS, COLORLESS, POISON GAS. CARBON MONOXIDE MAY BE PRESENT EVEN IF YOU DO NOT SMELL OR SEE ANY ENGINE EXHAUST. BREATHING CARBON MONOXIDE CAN CAUSE NAUSEA, FAINTING OR DEATH, IN ADDITION TO DROWSINESS, DIZZINESS AND CONFUSION.

IF YOU EXPERIENCE ANY OF THESE SYMPTOMS, SEEK FRESH AIR AND MEDICAL ATTENTION IMMEDIATELY.

CAUTION

HOT GASES ARE A NORMAL BY-PRODUCT OF A FUNCTIONING CATALYTIC CONVERTER. FOLLOW ALL SAFETY INSTRUCTIONS TO PREVENT BURNS AND FIRES.

DO NOT ALTER/MODIFY ENGINE:

NEVER ALTER OR MODIFY THE ENGINE FROM THE FACTORY. SERIOUS INJURY OR DEATH MAY OCCUR IF ENGINE IS MODIFIED OR ALTERED.

WHEN WORKING ON OR REPLACING PARTS FOR THE ENGINE OR PRODUCT, YOU MUST ALWAYS DISCONNECT SPARK PLUG WIRE FROM THE SPARK PLUG AND KEEP IT AWAY FROM THE SPARK PLUG.

Gasoline Fires and Handling Fuel Safely

Use extra care in handling gasoline and other fuels. They are flammable and vapors are explosive.

- When storing extra fuel be sure that it is in an appropriate container and away from any fire hazards.
- Prevent fire and explosion caused by static electric discharge. Use only nonmetal, portable fuel containers approved by the Underwriter's Laboratory (U.L.) or the American Society for Testing & Materials (ASTM).
- Always fill fuel tank outside in a well ventilated area. Never fill your fuel tank with fuel indoors. (Examples include: basement, garage, barn, shed, house, porch, etc.) Never fill tank near appliances with pilot lights, heaters, or other ignition sources. If the fuel has to be drained, this should be done outdoors. The drained fuel should be stored in a container specifically designed for fuel storage or it should be disposed of carefully.
- Never remove the fuel cap or add fuel with the engine running. Stop engine and allow to cool before filling.
- Never drain fuel from engine in an enclosed area.

- Always wipe up excess (spilled) fuel from engine before starting. Clean up spilled fuel immediately. If fuel is spilled, do not start the engine but move product and fuel container from area. Clean up spilled fuel and allow to evaporate and dry after wiping and before starting.
- Allow fuel fumes/vapors to escape from the area before starting engine.
- Test the fuel cap for proper installation before starting and using engine.
- Always run the engine with fuel cap properly installed on the engine.
- Never smoke while refilling engine fuel tank or while operating machine.
- Do not store engine with fuel in fuel tank indoors. Fuel and fuel vapors are highly explosive.
- Never pour fuel from engine fuel tank.
- Never siphon fuel by mouth to drain fuel tank.
- Always have an adult fill the fuel tank and never allow children to fill the engine.
- Never allow an adult or anyone under the influence of drugs or alcohol to fill engine.
- When storing gasoline or equipment with fuel in the tank, store away from furnaces, stoves, water heaters or other appliances that have a pilot light or other ignition source because they can ignite gasoline vapors.

BURNS AND FIRES

The muffler, muffler guard and other parts of the engine become extremely hot during the operation of the engine. These parts remain extremely hot after the engine has stopped.

Prevention of Burns and Fires

- Never remove the muffler guard from the engine.
- Never touch the muffler guard because it is extremely hot and will cause severe burns.
- Never touch parts of the engine that become hot after operation.
- Always keep materials and debris away from muffler guard and other hot parts of the engine to avoid fires.
- This engine is designed to operate using a catalytic converter which contributes to the engine's compliance with the EPA.

CHILDREN AND BYSTANDERS

Tragic accidents can occur if the operator is not alert to the presence of children and/or bystanders. Never assume that others will remain where you last saw them.

- Keep the area of operation clear of all persons, especially small children and pets. Keep children under the watchful care of a responsible adult.
- Be alert and turn machine off if children enter the area.
- Before and while moving backwards, look behind and down for small children.
- Never allow children to operate the machine.
- Use extra care when approaching blind corners, shrubs, trees, or other objects that may obscure vision.

SERVICE

- Always stop the engine whenever you leave the equipment, before cleaning, repairing or inspecting the unit. Engine should be turned off and cool, spark plug wire must be removed from spark plug before any repairs or adjustments are attempted. Never make adjustments or repairs with the engine (motor) running. Disconnect the spark plug wire, and keep the wire away from the plug to prevent accidental starting. Remove the ignition key if equipped with an electric start.
- Always wear eye protection when you make adjustments or repairs.
- Keep all nuts and bolts tight and keep equipment in good condition.
- Never tamper with safety devices. Check their proper operation regularly.
- When servicing or repairing the machine, do not tip the machine over or up unless specifically instructed to do so in this manual. Service and repair procedures can be done with the machine in an upright position. Some procedures will be easier if the machine is lifted on a raised platform or working surface.
- To reduce fire hazard, keep machine free of grass, leaves, or other debris build-up. Clean up oil or fuel spillage. Allow machine to cool before storing.
- Stop and inspect the equipment if you strike an object. Repair, if necessary, before restarting.
- Clean and replace safety and instruction decals as necessary.
- To guard against engine over-heating, always have engine debris filter mounted and clean.
- Inspect machine before storage. When not in use, disconnect spark plug lead and store indoors in a dry place locked or otherwise inaccessible to children.
- Use only original equipment parts from Earthquake®, including all nuts and bolts.

SAFETY DECALS

This rototiller unit has been designed and manufactured to provide you with the safety and reliability you would expect from an industry leader in outdoor power equipment manufacturing.

Although reading this manual and the safety instructions it contains will provide you with the necessary basic knowledge to operated this equipment safely and effectively, we have placed several safety labels on the tiller to remind you of this important information while you are operating the unit.

These important safety labels are illustrated below, and are shown here to help familiarize you with the location and content of the safety messages you will see as you perform normal tilling operations. Please review these labels now. If you have any questions regarding their meaning or how to comply with these instructions, reread the complete safety instruction text on the preceding pages, or contact your local dealer.

Should any of the safety labels become unreadable because of being worn, faded, or otherwise damaged during the use of your tiller, please use the part number information provided to order a replacement label from your local authorized dealer.

The safety labels are easily applied, and will act as a constant visual reminder to you, and others who may use the equipment. Follow the safety instructions necessary for safe, effective operation of your rototiller.

⚠ DANGER

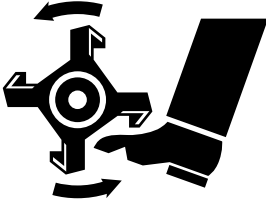

AVOID INJURY FROM ROTATING TINES!

Keep hands, feet and clothing away.

- Tines rotate when tiller is engaged.
- Tines rotate when drive control lever is pulled back.
- Releasing the drive control lever to neutral stops the tines.

OPERATION

REFER TO OPERATOR'S MANUAL FOR DETAILED OPERATING INSTRUCTIONS TO START:

1. Release drive control lever to neutral position.
2. Turn ON/OFF switch to ON position.
3. Move throttle control lever to fast position on engine.
4. Move choke lever to choke position on engine.
5. Pull starter rope until engine starts.
6. Move choke lever back to run position.

18088

Part No. 18088
TINES DANGER/OPERATION
Tine Shield Decal

⚠ WARNING

AVOID SERIOUS INJURY OR DEATH

- Read operator's manual(s).
- Know the location and function of all controls.
- Keep all shields and guards in place and working while running.
- Never operate tiller when children are around.
- Dress appropriately -- wear sturdy footwear.
- Carefully inspect area to be tilled -- remove large rocks and other foreign objects.
- Do NOT till above underground electric, water, gas, or other utility lines and pipes.
- STOP THE ENGINE AND DISCONNECT THE SPARK PLUG WIRE before removing debris or servicing unit.
- When leaving the operating position for any reason:
 - shut off the engine.
 - wait for all moving parts to stop.

18091

Part No. 18091
WARNING
Tine Shield Decal

⚠ WARNING

DO NOT START ENGINE UNLESS BELT COVER IS ATTACHED. KEEP HANDS, FEET, AND CLOTHING AWAY FROM MOVING BELTS AND PULLEYS. FAILURE TO COMPLY COULD RESULT IN INJURY. SEE OPERATOR'S MANUAL FOR FULL SAFETY INSTRUCTIONS.

LBL516C

Part No. LBL516C
BELT AND PULLEY WARNING
Belt Guard Decal

CLUTCH ENGAGE ↓

PLACE FREE HAND ON HANDLEBAR WHEN STARTING

LBL3100D

ENGAGE

Part No. LBL3100D
CLUTCH ENGAGE
Handlebar Decal

FEATURES (VECTOR™)

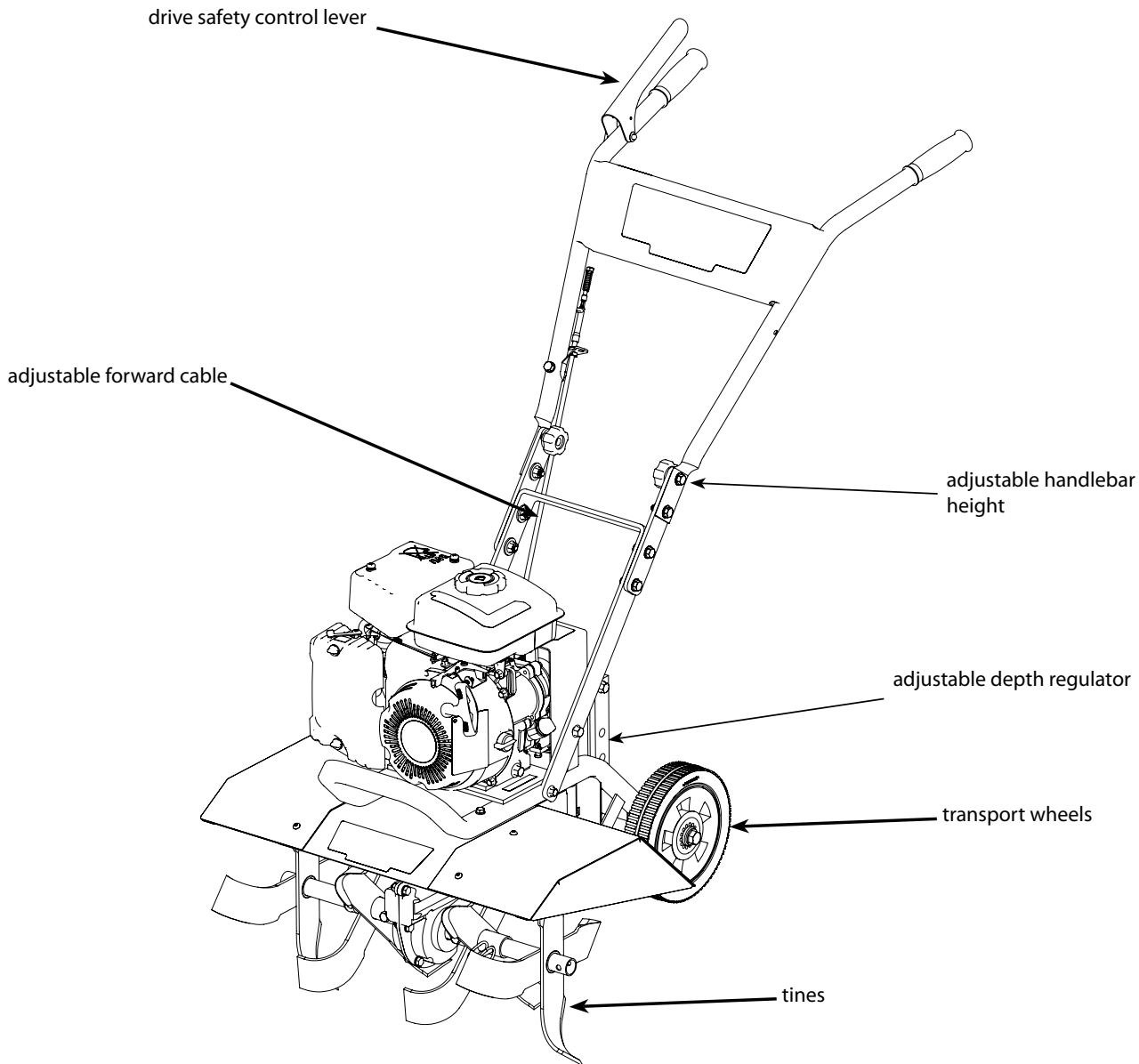

SPECIFICATIONS

ENGINE DISPLACEMENT	99cc
TILLING WIDTH	11 in., 16 in., 21 in.
TILLING DEPTH	11 in.
TINE SPEED	178 rpm
WHEEL SIZE	8" diameter
WEIGHT OF UNIT	90 lb
UNIT SIZE L x W x H (inches)	51" x 24" x 41"

UNPACKING AND ASSEMBLY

UNPACKING AND ASSEMBLING YOUR TILLER

1. Open top of carton and remove handlebar assembly.
2. Parts bag for Vector tiller contains:
 - 8- Bolts M8 x 1.25 x 25 Hex Head
 - 6- Washers M8 8.4mm x 24mm x 2.2mm
 - 6- Nuts M8 x 1.25
 - 2- Middle Handlebar Straps
 - 2- Hand Knobs
 - 6- Bolts M6 x 1.0 x 12
 - 6- Nylock Nuts M6 x 1.0
3. Remove machine from carton
4. Assemble the upper handlebar onto the lower handlebar loop. Use the two (2) middle handlebar straps to connect the upper handlebar to the lower handlebar loop. Put the M8 bolts through bolt holes from the outside in. Put on six (6) washers and tighten with six (6) M8 nuts on the six (6) lower bolts. Tighten the two (2) M8 hand knobs on the two (2) upper most bolts on each side of the handlebar. **SEE FIGURES 1 AND 2.** The two (2) upper bolts and hand knobs can be used in one of three hole positions for handlebar height adjustability. **SEE FIGURE 3.**

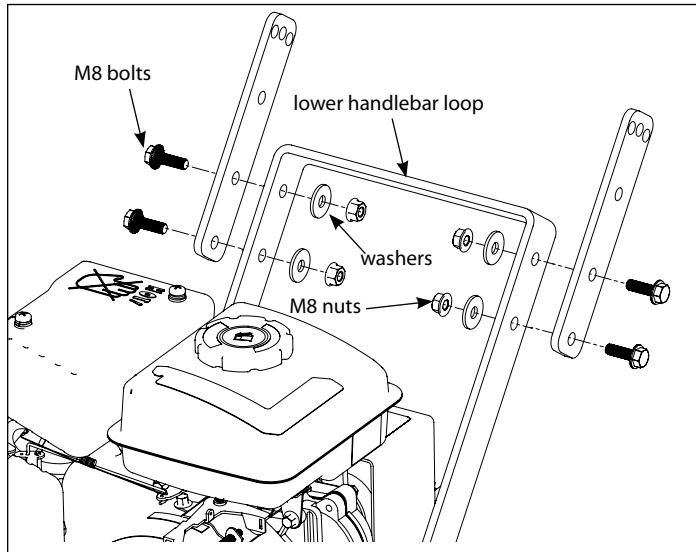
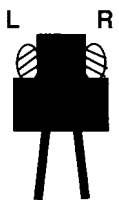

Figure 1

⚠ IMPORTANT

THE RIGHT AND LEFT SIDES OF YOUR ROTOTILLER ARE DETERMINED FROM THE OPERATING POSITION AS YOU FACE THE DIRECTION OF FORWARD TRAVEL.

ENGINE IS SHIPPED FROM FACTORY WITHOUT OIL. YOU MUST ADD ENGINE OIL BEFORE STARTING ENGINE.



⚠ CAUTION

DO NOT TRY TO LIFT THE ROTOTILLER FROM THE CARTON.

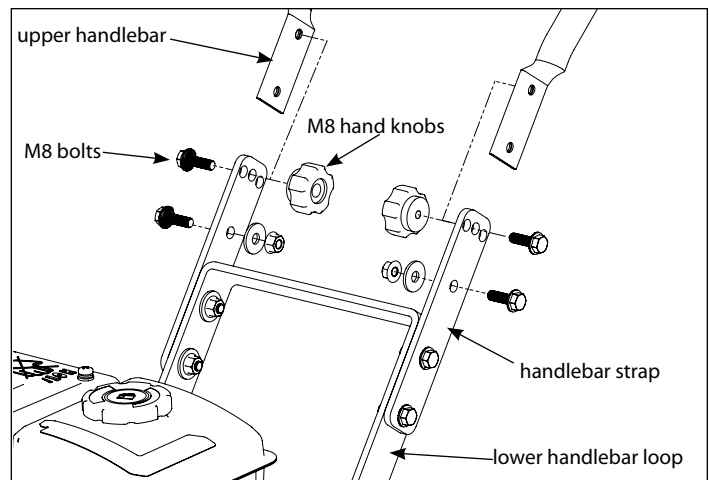

Figure 2

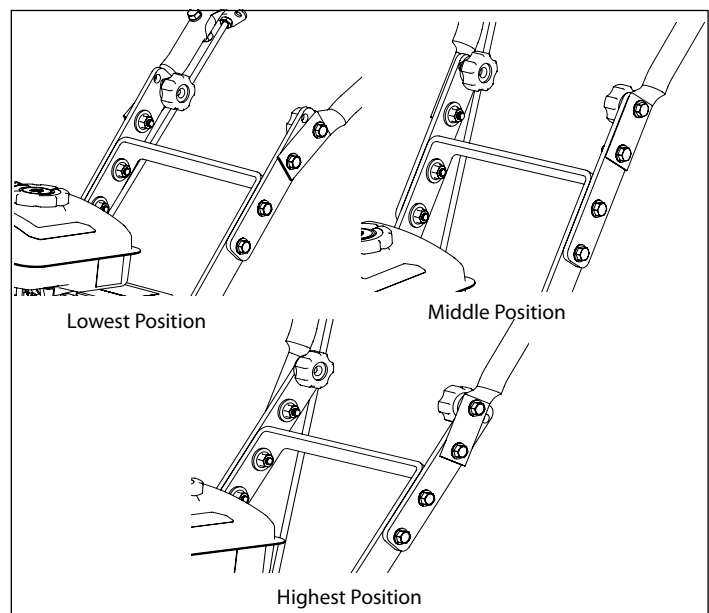

Figure 3

5. Assemble tine shield extensions using six (6) M6 bolts and six (6) nylock nuts. **SEE FIGURE 4.**
6. Assemble tines to unit. Sharp edges of tines will be away from the operator at the top or facedown at front of machine. Fasten outer tines to the inner tines using the 8mm x 40mm lock pins already affixed to the inner tines. Lock pins must be installed so that the pin enters the hole in the tine from the front of the tiller, and so the wire bale hinges over the top of the tine pipe and latches to the protruding pin on the back side of the tine. **SEE FIGURE 5.**
7. Install the drag stake assembly from the top down through the drag stake holder tube on the tiller frame between the wheels. Lock the drag stake in place using the detent pin that is already affixed to the drag stake holder tube. **SEE FIGURE 6.**

FILL ENGINE CRANKCASE

1. Add oil according to engine manual. **Do not overfill.** Use a clean, high quality detergent oil. Container must be marked A.P.I. Service SF - SJ. Use no special additives with recommended oils. **Do not mix oil with gasoline.** Oil level must be full. Check the oil level by removing oil fill plug. Oil level should be up to the bottom of the fill plug opening.
2. Always check oil level before starting engine. Refer to engine manual for capacity and type of oil to use.

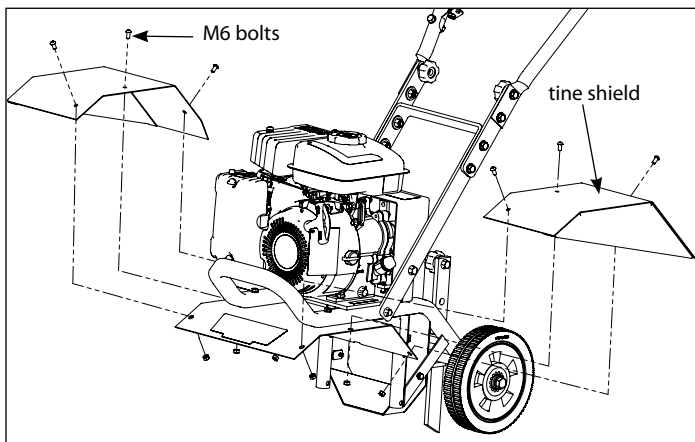

Figure 4

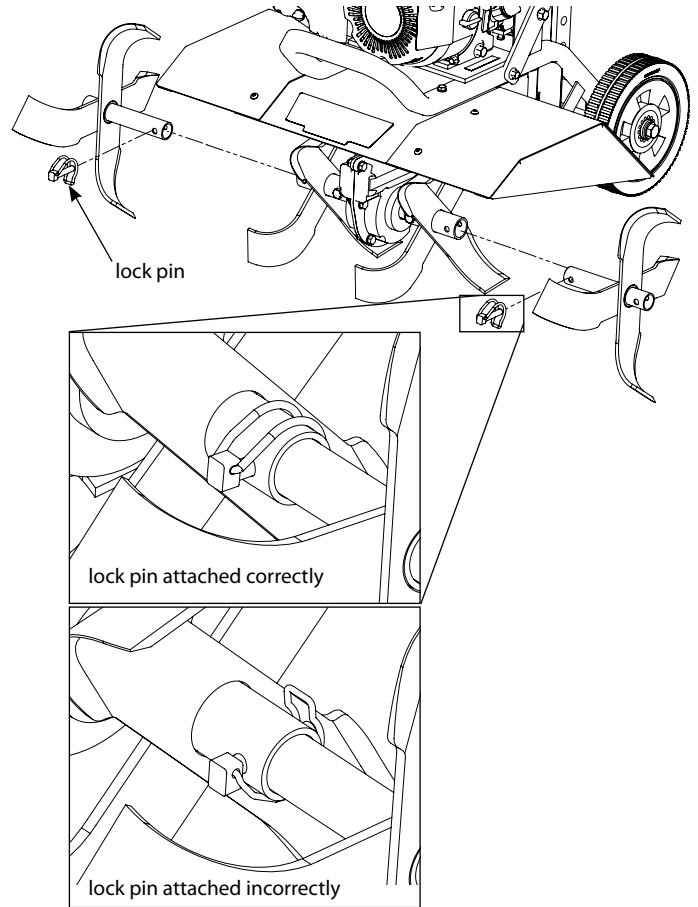

Figure 5

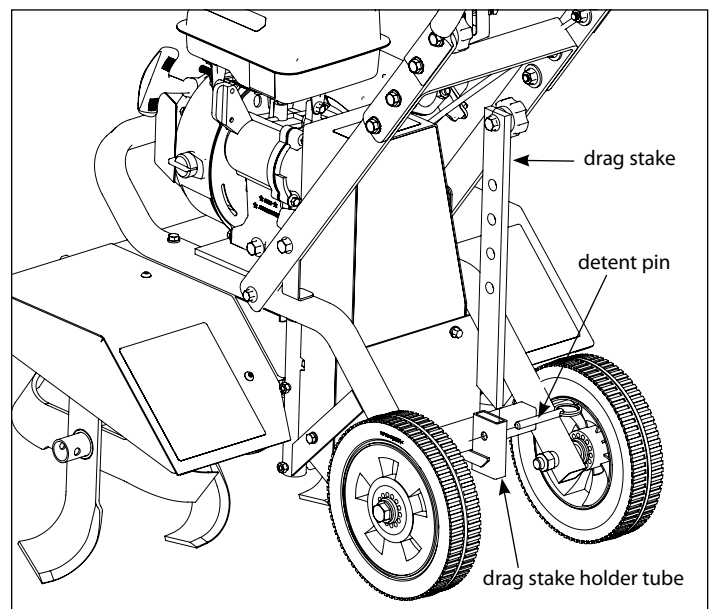

Figure 6

OPERATION CONTROLS

DRIVE SAFETY CONTROL LEVER

Engage tines into forward, releasing returns machine to neutral.

Pulling down on drive safety control lever engages the tines. Releasing the drive safety control lever to a neutral position disengages the tines.

BELT TENSION ADJUSTMENT

Proper belt tension is critical to good performance. After 1/2 hour of operation, all cables may have to be adjusted due to initial stretch. Thereafter, check tension after every 2 hours of operation.

To increase belt tension: SEE FIGURE 7.

1. Loosen upper jam nut. Turn nut up cable in 1/8" increments.
2. Tighten lower jam nut.
3. Check adjustment. Adjustment should not allow tines to direct drive when drive control lever is in neutral position.

This procedure can be repeated until conduit adjustment bolts have no more adjustment left. If no more adjustment can be made, belt may have to be replaced.

DRAG STAKE

Tilling depth is controlled by the height of the depth regulator lever. SEE FIGURE 8.

To adjust tilling depth.

1. Remove detent pin.
2. Raise the depth regulator lever to position tines at chosen tilling depth. Lowering the depth regulator will allow for deeper tilling.
3. Align hole in depth regulator lever with hole in depth regulator bracket and replace detent pin.

NOTE: Raise depth regulator all the way when transporting tiller. Lower the depth regulator all the way to maintain control of the tiller in harder soil conditions.

CAUTION

THIS INFORMATION IS PROVIDED HERE ONLY TO INTRODUCE THE CONTROLS. DO NOT START THE ENGINE AT THIS TIME. STARTING AND OPERATING INSTRUCTIONS ARE GIVEN ON PAGE 10. PLEASE READ THIS SECTION AND ALL OPERATING AND SAFETY INSTRUCTIONS BEFORE STARTING YOUR TILLER.

- **AS A SAFETY PRECAUTION, THE DRIVE SAFETY CONTROL LEVER WILL NOT LOCK IN THE FORWARD POSITION.**
- **TO STOP THE TINES AT ANY TIME RELEASE THE DRIVE SAFETY CONTROL LEVER.**

WARNING

ENGINE SHOULD BE OFF BEFORE ADJUSTING ANY CONTROLS.

DO NOT ADJUST TILLING DEPTH UNLESS DRIVE SAFETY CONTROL LEVER IS RELEASED TO THE NEUTRAL POSITION.

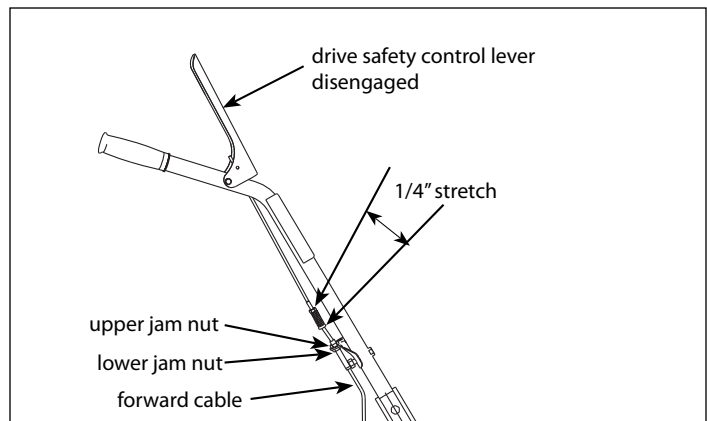

Figure 7: Vector Handlebar

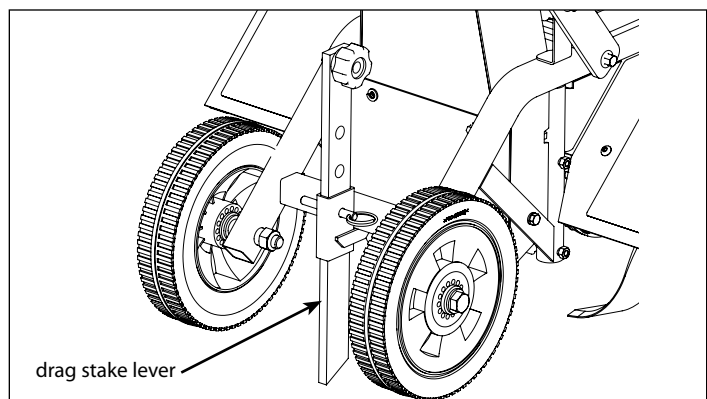

Figure 8: Drag Stake Lever

PRE-START INSPECTION

1. Make sure all safety guards are in place and all nuts and bolts are secure.
2. Check oil level in engine crankcase. See your engine manual for procedure and specifications.
3. Inspect air cleaner for cleanliness. See your engine manual for procedure.
4. Check the fuel supply. Fill the fuel tank no closer than 1 inch from top of tank to provide space for expansion. See your engine manual for fuel recommendations.
5. Be sure spark plug wire is attached and spark plug is tightened securely.
6. Check depth regulator lever position.
7. Examine underneath and around engine for signs of oil or fuel leaks.
8. Inspect fuel hoses for tightness and fuel seepage.
9. Look for signs of engine damage.
10. Remove excessive debris from muffler area and recoil starter.

START-UP

The controls required to start and run the rototiller are located on the engine.

The throttle speed control is located above the pull-start recoil and is indicated by a rabbit for FAST and a turtle for SLOW. The choke lever is located above the air cleaner cover. The On/Off switch is located on the side of the blower housing closest to the recoil pull handle.

A more detailed description of engine operation and all related precautions and procedures can be found in the engine manufacturer's manual that accompanies each tiller.

COLD STARTS

1. Turn the On/Off switch to the ON position
2. Move choke lever to full choke position.
3. Move throttle lever to run in the FAST position.
4. Pull starting rope out slowly one time and allow to return normally.
5. Pull starting rope out rapidly, and allow rope to return normally.
6. When engine starts, gradually move choke lever to run position and increase throttle speed to "FAST" position.

RESTARTING A WARM ENGINE

IMPORTANT

GASOLINE IS HIGHLY FLAMMABLE AND MUST BE HANDLED WITH CARE. NEVER FILL THE TANK WHEN THE ENGINE IS HOT OR RUNNING. ALWAYS MOVE OUTDOORS TO FILL THE TANK.

TEMPERATURE OF MUFFLER AND NEAR BY AREAS MAY EXCEED 150° F. AVOID THESE AREAS.

DO NOT MOVE CHOKE CONTROL TO CHOKE TO STOP ENGINE. BACKFIRE OR ENGINE DAMAGE MAY OCCUR.

TO STOP THE ENGINE AT ANY TIME, TURN THE ON/OFF SWITCH TO THE OFF POSITION. TO STOP TINES AT ANY TIME, RELEASE DRIVE SAFETY CONTROL LEVER TO THE NEUTRAL POSITION.

ALWAYS RELEASE DRIVE SAFETY CONTROL LEVER TO THE NEUTRAL POSITION AND TURN ENGINE OFF BEFORE ADJUSTING THE DEPTH OF THE REGULATOR LEVER.

CAUTION

PLEASE DO NOT START YOUR TILLER UNTIL YOU HAVE READ THE MANUAL THAT CAME WITH YOUR ENGINE, AND THE SECTIONS IN THIS MANUAL TITLED CONTROLS AND SAFETY. IF YOU HAVE READ THESE, FOLLOW THE STEPS IN THE START-UP SECTION TO START YOUR TILLER. ALWAYS PERFORM THIS PRE-START CHECKLIST BEFORE STARTING THE ENGINE.

IMPORTANT

ENGINE IS SHIPPED FROM FACTORY WITHOUT OIL. YOU MUST ADD ENGINE OIL BEFORE STARTING ENGINE.

PRACTICE OPERATING THE CONTROLS AND TILLER WITH TINES OUT OF GROUND BEFORE BEGINNING TO TILL. IT IS IMPORTANT THAT YOU KNOW HOW TO USE THE TILLER PROPERLY, KEEP CONTROL AT ALL TIMES, STOP THE TINES AND WHEELS FROM TURNING, AND STOP THE ENGINE IF NECESSARY. IF YOU DO NOT KNOW HOW TO DO THESE THINGS, READ THE CONTROLS AND SAFETY SECTIONS BEFORE PROCEEDING.

Restarting an engine that is already warm from previous running does not normally require use of the choke.

1. Turn the On/Off switch to the ON position.
2. Move throttle lever to run in the FAST position.
3. Pull starting rope out rapidly until engine starts. Allow rope to return normally. Repeat until engine starts.

OPERATING SPEED

For normal tilling, set the throttle lever to FAST.

SHUTTING DOWN

To stop the engine at any time, turn the On/Off switch to the OFF position. To stop tines at any time, release the drive safety control lever to the neutral position.

TILLING

1. Adjust the depth regulator lever to desired tilling depth.

NOTE: Raise depth regulator lever up one hole at a time, testing tiller operation after each raise. Raising depth regulator lever too high can result in loss of control of tiller!

2. Move the throttle control to **fast**.
3. Place the tiller in motion by pushing down on the drive safety control lever--this will engage the tines.

MAINTENANCE AND STORAGE

Your rototiller has been designed and produced by the industry's leading manufacturer of outdoor power equipment to provide you with years of reliable operation.

Please read the maintenance schedule in this manual for the tiller, and the maintenance schedule and recommendations in the accompanying engine manual. Observe these recommendations to extend the life of your product.

Good maintenance is essential for safe, economical, and trouble-free operation. Keeping your tiller in top running condition will prolong its life, and help you obtain optimum performance. It will also help reduce air pollution. To help you properly care for your engine, the following pages include a maintenance schedule, routine inspection procedures, and simple maintenance procedures using basic hand tools. Other service tasks that are more difficult, or require special tools, are best handled by professionals and are normally performed by a technician or other qualified mechanic.

Maintenance, replacement or repair of the emissions control devices and systems may be performed by any non-road engine repair establishment or individuals. However, items must be serviced by an authorized dealer to obtain "no charge" emissions control warranty service.

The maintenance schedule applies to normal operating conditions. If you operate your tiller under unusual conditions, such as sustained high-load or high-temperature operation, or use in unusually wet or dusty conditions, consult your servicing dealer for recommendations applicable to your individual needs and use.

DANGER

ENGINE AND SURROUNDING PARTS BECOME EXTREMELY HOT DURING NORMAL USE AND WILL CAUSE SERIOUS BURN INJURIES IF TOUCHED BEFORE THE ENGINE HAS COOLED.

ALLOW ENGINE TO COOL COMPLETELY BEFORE TOUCHING THESE HOT SURFACES.

ALWAYS KEEP HANDS AND FEET CLEAR OF ROTATING MACHINE PARTS.

WARNING

EXTREME CAUTION MUST BE TAKEN IN SELECTING TILLING DEPTH. IF YOU ATTEMPT TO TILL WITH THE DRAG STAKE IN TOO HIGH OF A POSITION FOR CERTAIN SOIL CONDITIONS, LOSS OF CONTROL COULD RESULT.

IF REMOVING MATERIAL FROM THE TINES BY HAND, STOP ENGINE AND REMOVE SPARK PLUG WIRE FIRST.

MAINTENANCE SCHEDULE

Maintenance Operation	Page	Before Each Use	50 hours or Every Season
Check belt tension	11	X	
Change drive belt	14		X
Engine maintenance	15	X	X
Check or fill engine crankcase	15	X	1
Clean tine axle shaft	15	X	
Lubrication	15		X

EM = See engine manual

1 Change oil after first 5-8 hours of use, then after every 50 hours or every season. Change oil every 25 hours when operating under heavy load or in high temperatures.

SERVICING THE ROTOTILLER

The following information will help you make the necessary checks and perform the procedures required to follow the normal care recommendations made for your rototiller unit.

If you prefer, your local authorized dealer can make these checks and perform the required procedures for you.

CHECK BELT TENSION

Belt tension may decrease over time. It must be adjusted within the first half hour of operation, and checked after every two hours of operation. Proper adjustment will assure long belt life. Too much or too little belt tension will cause premature belt failure. To check and adjust the forward belt tension:

1. Turn off engine. Engine must be cool.
2. Remove spark plug wire from spark plug and secure.
3. With drive safety control lever in the neutral position, measure length of spring when in its relaxed state.
4. Pull down on drive safety control lever and measure length of spring when compressed. Ideal length would be 1/4" shorter. **SEE FIGURE 9.**

CHANGE DRIVE BELT

1. Turn off engine. Engine must be cool.
2. Remove spark plug wire from spark plug and secure.
3. Remove top and lower belt guards (18129 and 18123). **SEE FIGURE 10.**
 - remove the belt from the engine pulley:
 - gently pull the engine recoil rope to rotate the pulley.
 - with the pulley turning, force the belt out of the groove.
 - slide the belt free of the engine pulley.
 - pull the belt down and out of the way.
 - push the belt down and away from the transmission pulley to remove.
 - install new belt:
 - place belt in transmission pulley groove.
 - gently pull the engine recoil rope to rotate the pulley while forcing the belt into the groove.
4. Replace top and lower belt guards (18129 and 18123).
5. Recheck belt tension and adjust if necessary
6. Attach spark plug wire.

WARNING

CHECK FORWARD BELT TENSION REGULARLY. TOO MUCH OR TOO LITTLE TENSION WILL CAUSE PREMATURE BELT FAILURE.

WARNING

TO PREVENT ACCIDENTAL STARTING:

ENGINE MUST BE TURNED OFF AND COOL, AND SPARK PLUG WIRE MUST BE REMOVED AND SECURED FROM SPARK PLUG BEFORE CHECKING AND ADJUSTING ENGINE OR EQUIPMENT.

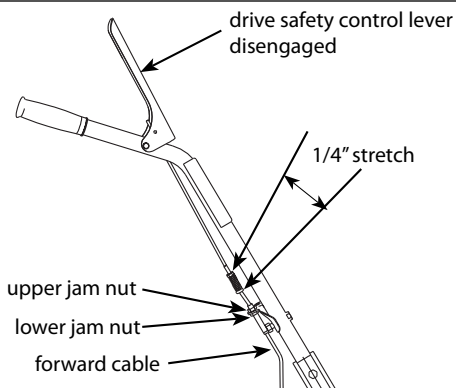
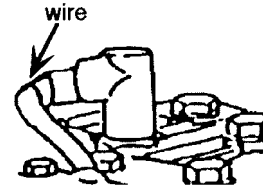

Figure 9: Vector Handlebar

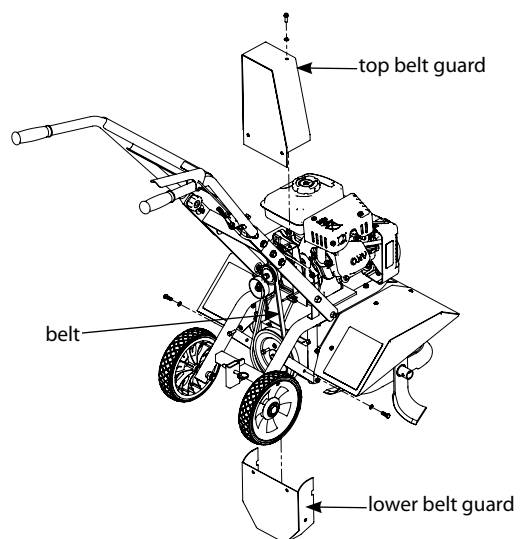

Figure 10: Changing the tiller belt

ENGINE MAINTENANCE

Refer to the engine manual included in your parts packet for information on engine maintenance. Your engine manual provides detailed information and a maintenance schedule for performing the following tasks:

1. Check oil level before each use or after every 8 hours of operation.
2. Change oil after first 5-8 hours of operation. Change oil while engine is warm. Refill with new oil of recommended grade.
4. Check spark plug seasonally or every 100 hours of operation.
5. Service air cleaner.
6. Keep engine and parts clean.
7. Check engine and equipment often for loose nuts and bolts, keep these items tightened.

CHECK OR FILL ENGINE CRANKCASE

1. Add oil according to engine manual. **Do not overfill.** Use a clean, high quality detergent oil. Container must be marked A.P.I. Service SF - SJ. Use no special additives with recommended oils. **Do not mix oil with gasoline.** Oil level must be full. Check the oil level by removing oil fill plug. Oil level should be up to the bottom of the fill plug opening on most engines.
2. Always check oil level before starting engine. Refer to engine manual for capacity and type of oil to use.

CLEAN TINE AXLE SHAFT

1. Turn off engine. Engine must be cool.
2. Remove spark plug wire and secure from spark plug.
3. Remove all vegetation, string, wire, and other material that may have accumulated on the axle between the inside set of tines and the seal on the transmission housing.
4. Replace spark plug wire.

LUBRICATION

Proper lubrication of moving mechanical parts is critical for proper care and maintenance. Oil the moving parts using a 30 weight oil.

STORAGE

PREPARE FOR STORAGE

Follow the steps below to prepare your tiller for storage. Read your engine manual for detailed instructions on preparing the engine for storage.

1. Protect tines and tine shafts from rust:
 - Coat the tine shaft lightly with axle grease.
2. Drain fuel system completely following engine manufacturer's

WARNING

TEMPERATURE OF MUFFLER AND NEAR BY AREAS MAY EXCEED 150° F. AVOID THESE AREAS.

WARNING

DO NOT STORE TILLER IN AN UNVENTILATED AREA WHERE FUEL FUMES MAY REACH FLAME, SPARKS, PILOT LIGHTS OR AN IGNITED OBJECT. DRAIN FUEL OUTDOORS AWAY FROM ANY IGNITION SOURCES. USE ONLY APPROVED FUEL CONTAINERS.

CAUTION

DO NOT OPERATE TILLER BEFORE READING THE ENGINE MANUAL PROVIDED IN THE PARTS PACKET.

IMPORTANT

ENGINE IS SHIPPED FROM FACTORY WITHOUT OIL. YOU MUST ADD ENGINE OIL BEFORE STARTING ENGINE.

ENGINE CAN OVERHEAT AND BECOME DAMAGED IF DEBRIS BLOCKS THE COOLING SYSTEM OR ROTATING SCREEN.

NEVER RUN ENGINE WITHOUT COMPLETE AIR CLEANER INSTALLED ON ENGINE.

instructions or add fuel stabilizer to prevent fuel from gumming up during extended storage period.

3. While engine is still warm, drain the oil from the engine. Refill with fresh oil of the recommended grade.
4. Clean external surfaces, engine and cooling fan.
5. Remove spark plug, pour one ounce of SAE 30 oil into spark plug hole.
6. Plug hole and pull starter cord slowly to distribute oil evenly in cylinder head area.
7. Reinstall spark plug.
8. Transport unit to a suitable storage location. If you have chosen to use a fuel stabilizer and have not drained the fuel system, follow all safety instructions storage precautions in this manual to prevent the possibility of fire from the ignition of gasoline fumes. Remember, gasoline fumes can travel to distant sources of ignition and ignite, causing risk of explosion and fire.
9. If there is any possibility of unauthorized use or tampering, remove the spark plug and store it in a safe place before storing the rototiller unit. Be sure to plug the spark plug hole to prevent foreign material from entering.

TROUBLESHOOTING AND REPAIR

TROUBLESHOOTING GUIDE

While normal care and routine maintenance will extend the life of your rototiller, prolonged or constant use may eventually require that service be performed to allow it to continue operating properly. The troubleshooting guide below lists the most common problems, causes and remedies.

 WARNING

PRACTICE SAFETY AT ALL TIMES. ENGINE MUST BE TURNED OFF AND ALLOWED TO COOL, AND SPARK PLUG WIRE MUST BE DISCONNECTED AND SECURED BEFORE ATTEMPTING ANY MAINTENANCE OR REPAIR. FAILURE TO COMPLY WITH THIS SAFETY REQUIREMENT CAN RESULT IN SERIOUS PERSONAL INJURY TO YOU OR BYSTANDERS.

PROBLEM	REMEDY/ACTION
Engine will not start	<ul style="list-style-type: none"> • Add gas to gas tank. • Connect spark plug wire to spark plug • Throttle must be positioned at choke for a cold start
Engine runs rough, floods during operation	<ul style="list-style-type: none"> • Clean or replace air cleaner
Engine is hard to start	<ul style="list-style-type: none"> • Drain old fuel and replace with fresh. Use gas stabilizer at end of season • Make sure spark plug wire is securely attached to spark plug • Drive safety control lever must be released to neutral to start the engine
Engine misses or lacks power	<ul style="list-style-type: none"> • Raise the tines for shallower tilling by raising the depth regulator lever • Clean or replace air cleaner • Improper carburetor adjustment, take to authorized engine service center • Replace spark plug and adjust gap • Drain and refill gas tank and carburetor
Tiller moves forward during starting	<ul style="list-style-type: none"> • Drive safety control lever must be released to neutral to start the engine
Tiller is difficult to control when tilling (machine jumps or lurches forward)	<ul style="list-style-type: none"> • Lower engine speed in hard ground • Lower the depth regulator for greater control of the tiller
Belts squeal in forward operation	<ul style="list-style-type: none"> • Adjust belt tension • Replace drive belt
Excessive heat build up in transmission/tine area during tilling	<ul style="list-style-type: none"> • Remove vegetation • Check transmission lubrication and fill if needed

PARTS BREAKDOWN VECTOR™ ENGINE ASSEMBLY PARTS EXPLOSION

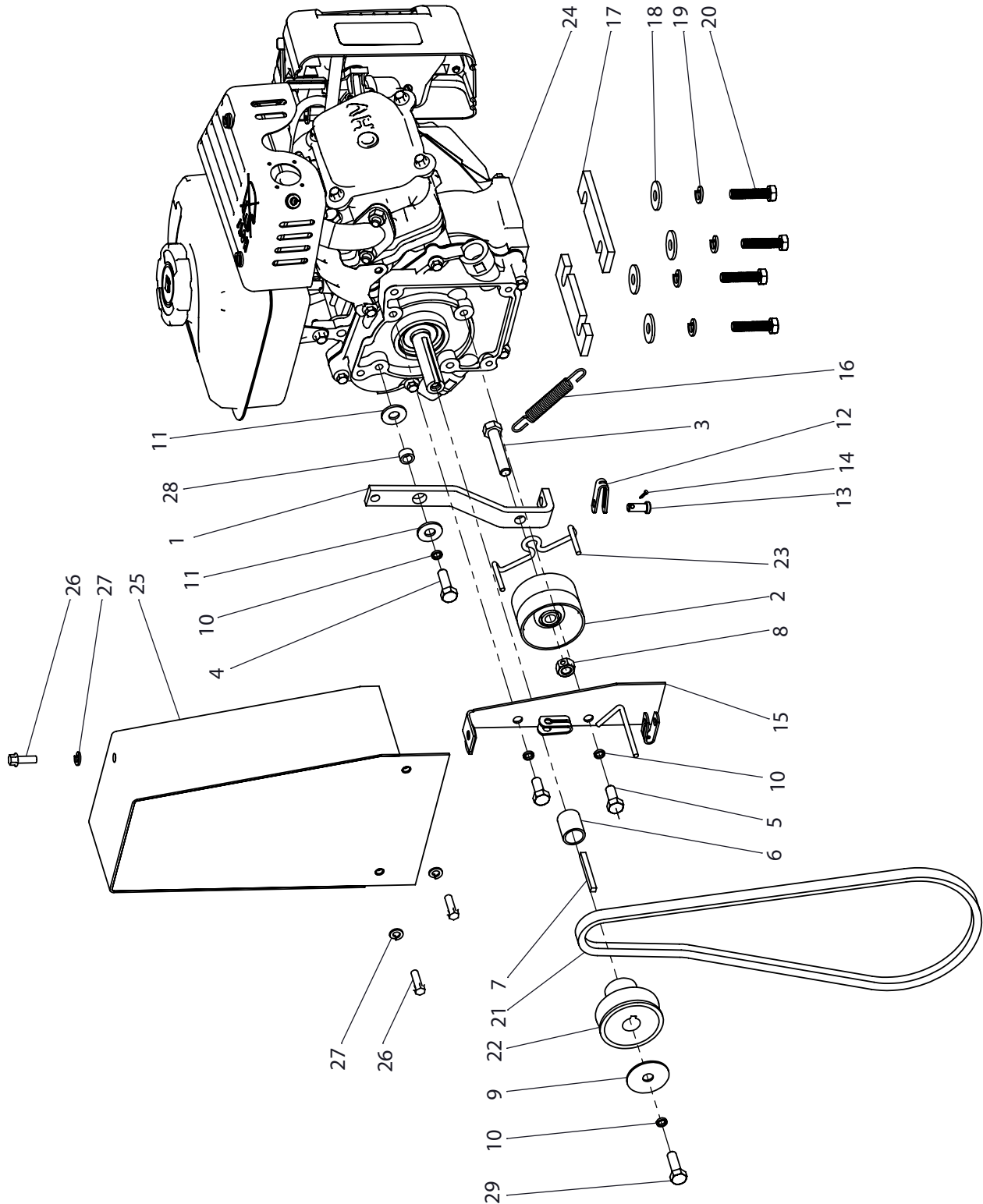



VECTOR™ ENGINE ASSEMBLY PARTS LIST

REF. NO.	PART #	DESCRIPTION	QTY.
1	53617	ARM FORWARD REAR TINE	1
2	1408	PULLEY IDLER FORWARD	1
3	48144B	BOLT 3/8-16 X 2 HHCS GR5 ZN	1
4	810	BOLT 5/16-24 X 1 HH GR5	2
5	802	BOLT 5/16-24 X 3/4 HH GR5 ZN	2
6	18008	BUSHING 16.4MM X 22MM X 21.5MM	1
7	38397	KEY 3/16IN X 1.75IN	1
8	2104	NUT 3/8-16 HBW GR5 ZN	1
9	803	WASHER 5/16"ID X 1-1/2"OD FLAT 16 GA.	1
10	504	LOCKWASHER-SPRING 5/16"	4
11	WF516	WASHER PLAIN 5/16 ZN	2
12	53596B	YOKE ZINC PLATED CLEVIS	1
13	1416	PIN CLEVIS	1
14	1418	PIN-COTTER	1
15	18015	WELDMENT CABLE GUIDE PLATE	1
16	1407	SPRING FORWARD ARM	1
17	18043	SHIM .25 IN ENGINE MOUNT	2
18	3245	WASHER M8 8.4MM X 24MM X 2.2MM ZN	4
19	W1200114	WASHER M8 X 1.9 SPRLK BLK OX HIGH COLLAR	4
20	18134	BOLT M8 X 1.0 X 35 GR8.8 ZN	4
21	18036	BELT V POWER RATED 861 MM	1
22	18022	PULLEY SINGLE GROOVE 16MM ID	1
23	739	BELT GUIDE REVERSE	1
24	18100	ENGINE RATO 99CC HORIZONTAL SHAFT	1
25	18129	WELDMENT GUARD PULLEY TOP	1
26	4647	BOLT M6 X 1.0 X 18 FLANGE HH GR5 ZN F-T	3
27	W1200116	WASHER M6 X 1.5 SPRLK ZN HIGH COLLAR	3
28	53637	BUSHING - FORWARD ARM REAR TINE	1
29	10677	BOLT M6 X 1.0 X 28 HH GR5	1

VECTOR™ HANDLEBAR ASSEMBLY PARTS EXPLOSION AND LIST

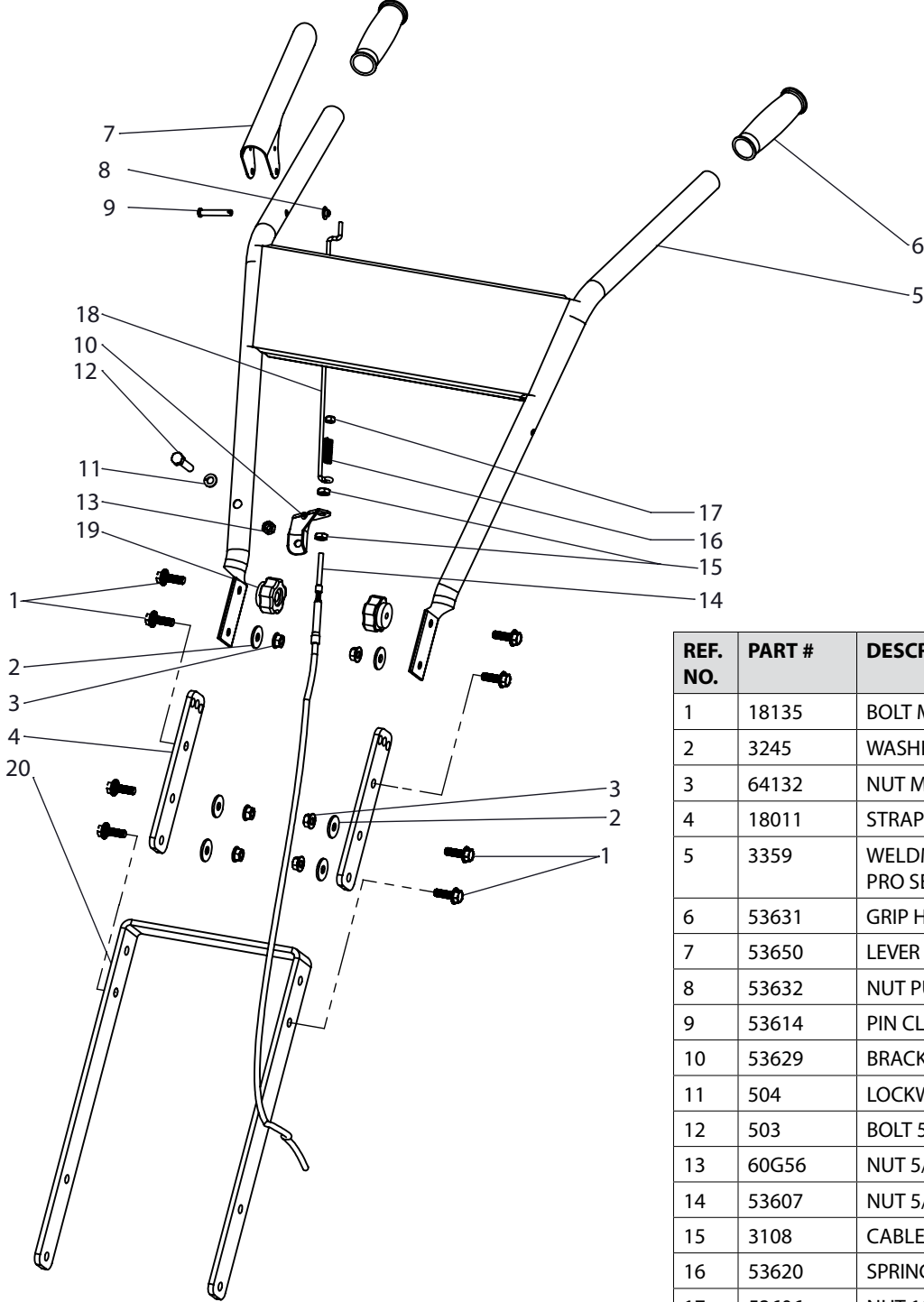

REF. NO.	PART #	DESCRIPTION	QTY.
1	18135	BOLT M8 X 1.25 X 25 SFH GR8.8 ZN	8
2	3245	WASHER M8 8.4MM X 24MM X 2.2MM ZN	6
3	64132	NUT M8 X 1.25 HSF	6
4	18011	STRAP HANDLE BAR MIDDLE	2
5	3359	WELDMENT, HANDLEBAR FRONT TINE PRO SERIES	1
6	53631	GRIP HANDLEBAR	2
7	53650	LEVER CONTROL	1
8	53632	NUT PUSH 1/4	1
9	53614	PIN CLEVIS 1/4 X 1 1/2	1
10	53629	BRACKET CABLE MOUNT	1
11	504	LOCKWASHER-SPRING 5/16"	1
12	503	BOLT 5/16-18 X 1-1/2 HH	1
13	60G56	NUT 5/16-18 BI-WAY LOCK GR5 ZN	1
14	53607	NUT 5/16-24 HEX JAM	2
15	3108	CABLE FRONT TINE PULLEY ENGAGE	1
16	53620	SPRING COMPRESSION FORWARD ARM	1
17	53606	NUT 10-24 HEX NYLOCK GR5	1
18	53612	LINK 295MM LONG	1
19	18052	KNOB M8 BLACK FIVE STAR	2
20	18010	HANDLEBAR LOWER STRAP	1

VECTOR™ CHASSIS ASSEMBLY PARTS EXPLOSION

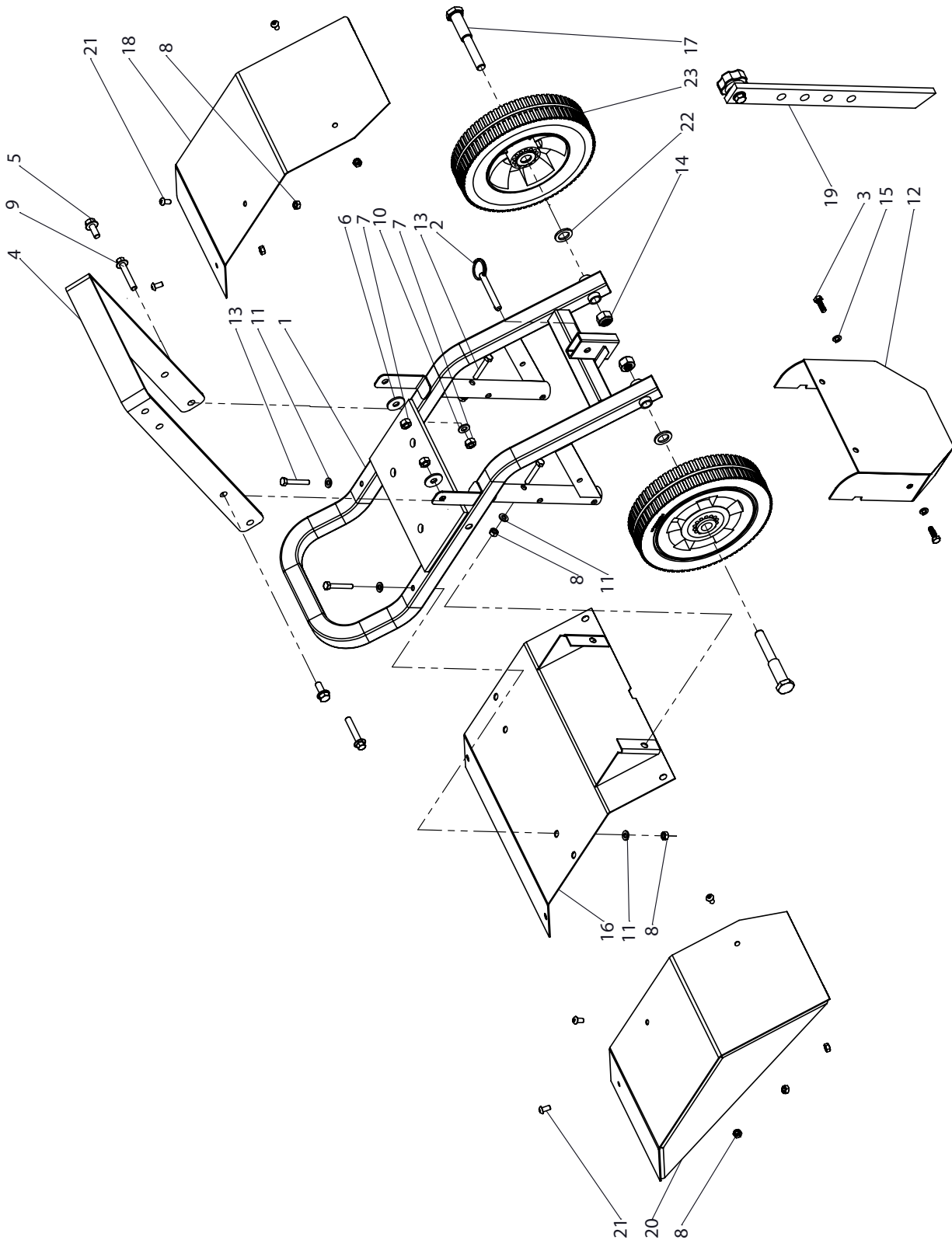



VECTOR™ CHASSIS ASSEMBLY PARTS LIST

REF. NO.	PART #	DESCRIPTION	QTY.
1	18004	WELDMENT VECTOR FRAME	1
2	69170	DETENT PIN 5/16IN X 2IN ZN	1
3	92776	BOLT M6 X 1.0 X 20 HHCS GR8.8 ZN	2
4	18010	HANDLEBAR LOWER STRAP	1
5	W1265V0904	BOLT M8 X 1.25 X 20 HHCS ZN GR8.8	2
6	3245	WASHER M8 8.4MM X 24MM X 2.2MM ZN	2
7	3252	NUT M8 X 1.25 H GR8.8 ZN	4
8	W1265V0913	NUT M6 X 1.0 HNYLK GR8.8 ZN	10
9	3247	BOLT M8 X 1.25 X 45 HHFCS GR8.8 ZN	2
10	400024	WASHER FLAT M8 8.4 X 16 X 1.6 THK GR8.8 ZN	2
11	W1200117	WASHER M6 X 13 X 1.75 FLAT ZN	6
12	18123	WELDMENT GUARD PULLEY LOWER	1
13	18103	BOLT M6 X 1.0 X 40 HH GR 8.8 ZN	4
14	331052	NUT M12 X 1.75 HH NYLCK GR8.8 ZN	2
15	W1200116	WASHER M6 X 1.5 SPRLCK ZN	2
16	18119	WELDMENT SHIELD TINE MIDDLE	1
17	10513	BOLT M12 X 1.5 X 96 HH SHLDR M15.7 X 42	2
18	18118	WELDMENT SHIELD TINE RIGHT	1
19	18131	ASSEMBLY DRAG STAKE	1
20	18116	WELDMENT SHIELD TINE LEFT	1
21	18058	BOLT M6 x 1.0 x 12 SBHCS GR8.8 ZN	6
22	10517	WASHER 16MM ID X 25MM OD X 2.5 THK ZN	2
23	10518	WHEEL 200MM OD X 42 MM	2

VECTOR™ TRANSMISSION ASSEMBLY PARTS EXPLOSION AND LIST

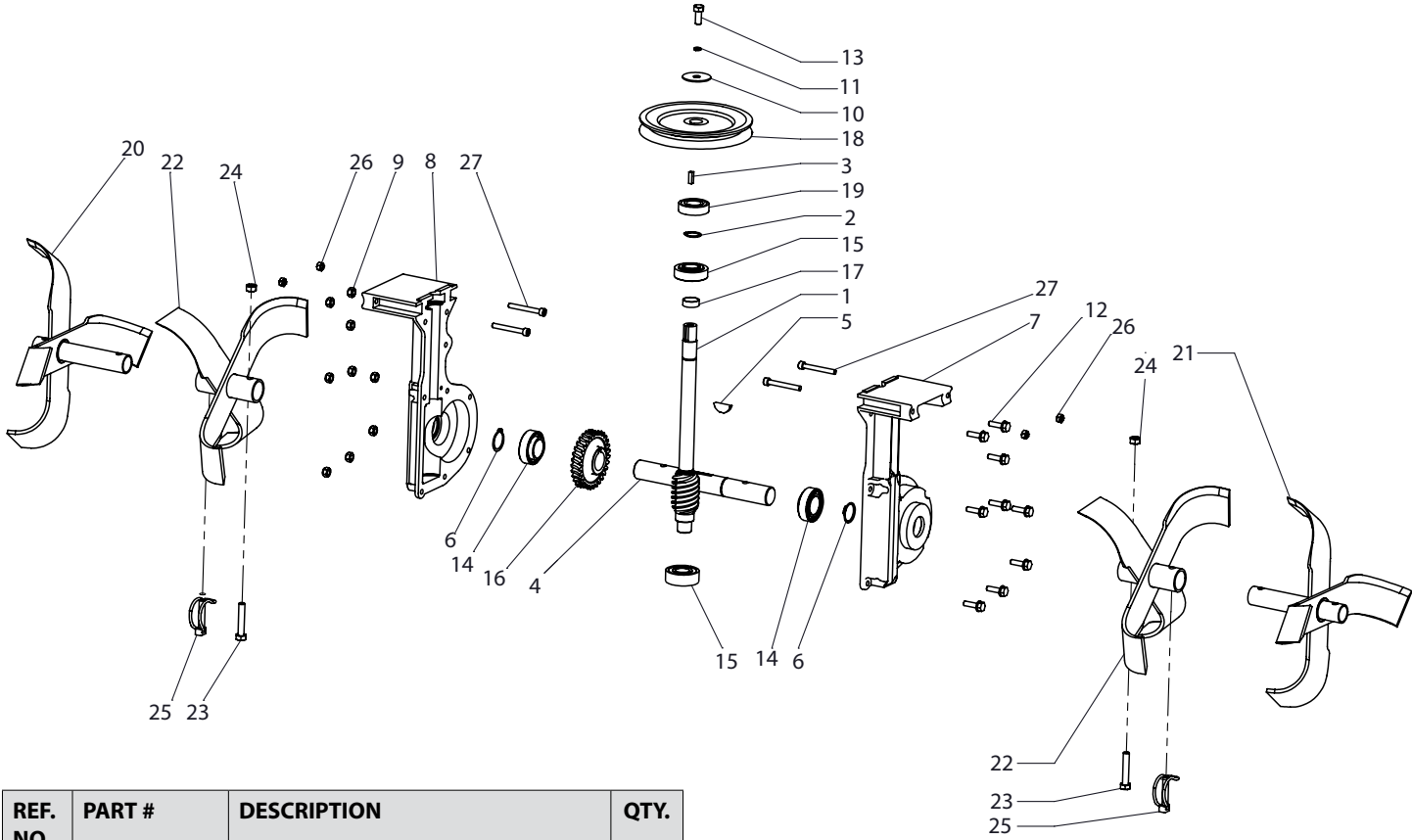

REF. NO.	PART #	DESCRIPTION	QTY.
1	18056	DRIVE SHAFT ASSEMBLY VECTOR TILLER	1
2	8924	RING RETAINING EXTERNAL 3/4 INCH	1
3	3364	KEY SQUARE 3/16 X 5/8	1
4	3322	TINE SHAFT 1" FT	1
5	1701	KEY 1/4 X 1 HALFMOON	1
6	1810	SNAP RING 1" PHOSPHATE EXTERNAL	2
7	56102*	CASTING ALUMINUM FT RIGHT SIDE	1
8	56012*	CASTING - ALUMINUM FT LEFT SIDE	1
9	67538	NUT 1/4-20 HNYLK ZN	9
10	803	WASHER 5/16"ID X 1-1/2"OD FLAT 16 GA.	1
11	1916965	WASHER 1/4" SPRING LOCK ZINC	1
12	1511	BOLT 1/4 - 20 X 7/8 SFHH ZN	9
13	802	BOLT 5/16-24 X 3/4 HH GR5 ZN	1
14	3205W	BEARING 1" ID CUSTOM FULL WIDTH	2
15	1601	BEARING TAPERED INCLUDES CONE AND RACE	2

REF. NO.	PART #	DESCRIPTION	QTY.
16	3116	GEAR BRASS 1" ID FRONT TINE TILLER	1
17	18032	BUSHING 20MM X 25MM X 8.4MM	1
18	3179	PULLEY, TRANSMISSION SINGLE GROOVE	1
19	8922	BEARING BALL R12 DOUBLE LIP SEALED 3/4 IN. I.D.	1
20	3323	WELDMENT TINE OUTSIDE FRONT RIGHT SET	1
21	3326	WEDLMENT TINE OUTSIDE FRONT LEFT SET	1
22	3324	WELDMENT TINE SET INSIDE	2
23	18098	BOLT M8 x 1.25 x 45 HH GR8.8 ZN	2
24	3252	NUT M8 X 1.25 H GR8.8 ZN	2
25	18039	LOCK PIN 8MM X 40MM (38.1MM USABLE) BLACK	2
26	W1265V0913	NUT M6 X 1.0 HNYLK GR8.8 ZN	4
27	18137	BOLT M6 x 1.0 x 50 H SHCS GR 8.8 ZN	4

*Right and left castings sold as set only (P/N 56012)



FRONT TINE ROTOTILLERS

1-YEAR LIMITED WARRANTY

Terms and Conditions

Ardisam, Inc., a manufacturing company, warrants this **EARTHQUAKE® VECTOR COMPACT TILLER** to be free from defects in the material or workmanship for a period of one year from the date of purchase. During the one-year warranty of this product, Ardisam will, at its discretion, furnish parts and labor to correct any defect caused by faulty material or workmanship. Items subject to normal wear and tear, such as belts, batteries, tines, shear bolts and tires, due to the nature of their function are not covered under this warranty. Any unit used in a commercial application is covered for a period of 90 days after purchase. The engine is covered under a separate warranty issued by the engine manufacturer as stated in the engine manual.

If warranty work needs to be done, contact your place of purchase or Ardisam, Inc. for an authorized service center in your area. Ardisam will make the necessary repairs if a service center is not available. **To obtain warranty service and/or replacement instructions, you must have prior approval from Ardisam before shipping your package to us by calling our customer service department at 800-345-6007 for a return material authorization number (RMA#).** All items must be shipped prepaid. Ardisam, Inc. will at no charge, repair or replace, at their discretion, any defective part which falls under the conditions stated above.

Ardisam retains the right to change models, specifications and price without notice. This product if used as intended, will give you years of trouble free service. We hope you will enjoy the quality of our products for years to come.

For replacement parts, phone 800-345-6007 or go online to www.getearthquake.com.

This warranty applies to the original owner with a proof of purchase and is not transferable. It supersedes all other warranties either expressed or implied and all other obligations to liabilities on our part. Ardisam, Inc. does not assume, and does not authorize any other person to assume for us, any liability in connection with the sale of our products.

The warranty applies only to products which have not been subjected to negligent use, misuse, alteration, accident or repairs made by anyone not certified by Ardisam, Inc. This guarantee is void unless the warranty card is properly filled out and received by Ardisam, Inc., within 30 days of purchase or go to www.getearthquake.com for online registration.

EARTHQUAKE®
A Division of Ardisam, Inc.
1160 Eighth Avenue; P.O. Box 666
Cumberland, Wisconsin 54829
800-345-6007 · Fax (715) 822-4180
E-mail: info@ardisam.com



Earthquake®, Division of Ardisam, Inc.
1160 8th Avenue, PO Box 666
Cumberland, WI 54829
800-345-6007 | Fax 715-822-2223
E-mail: info@ardisam.com