

TFX-950CM Stage Wash™ 950

USER MANUAL

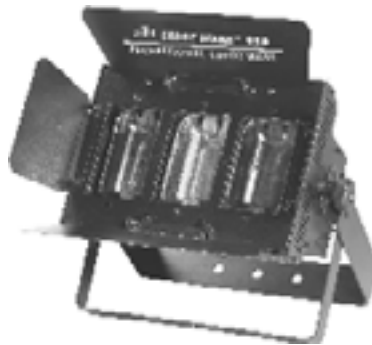

Chauvet, 3000 N 29th Ct, Hollywood, FL 33020 U.S.A
(800) 762-1084 – (954) 929-1115
FAX (954) 929-5560
www.chauvetlighting.com

TABLE OF CONTENT

BEFORE YOU BEGIN	3
WHAT IS INCLUDED.....	3
UNPACKING INSTRUCTIONS.....	3
AC POWER.....	3
SAFETY INSTRUCTIONS.....	3
INTRODUCTION.....	4
FEATURES.....	4
DMX CHANNEL SUMMARY.....	4
PRODUCT OVERVIEW.....	5
SETUP.....	6
LAMP.....	6
POWER.....	6
MOUNTING.....	7
OPERATING INSTRUCTIONS.....	8
OPERATING MODES.....	8
<i>Stand Alone Mode</i>	8
<i>Master/Slave</i>	9
<i>DMX Mode</i>	9
<i>TFX-SWF Easy Controller (Optional)</i>	11
<i>TFX-CONPK Stage Wash™ Controller Pack (Optional)</i>	11
APPENDIX.....	12
DMX PRIMER.....	12
DMX CHANNEL VALUES.....	13
<i>RGB&D Mode (RGB and Dimmer)</i>	13
<i>C&B Mode (Color and Brightness)</i>	13
<i>RGB and Chase Mode</i>	13
COLOR MIX TABLE (PRESET).....	14
MAINTENANCE.....	18
RETURNS PROCEDURE.....	19
CLAIMS.....	19
GENERAL TROUBLESHOOTING.....	20
TECHNICAL SPECIFICATIONS.....	21

BEFORE YOU BEGIN

What is included

- 1 x Stage Wash™ 950CM (TFX-950CM)
- Power cord with plug
- 3 x EHM 300w 120v or 3 x EHM2 300w 230v lamps
- Warranty Card & Manual

Unpacking Instructions

Immediately upon receiving a fixture, carefully unpack the carton, check the contents to ensure that all parts are present, and have been received in good condition. Notify the shipper immediately and retain packing material for inspection if any parts appear damaged from shipping or the carton itself shows signs of mishandling. Save the carton and all packing materials. In the event that a fixture must be returned to the factory, it is important that the fixture be returned in the original factory box and packing.

AC Power

To determine the power requirements for a particular fixture, see the label affixed to the back plate of the fixture or refer to the fixture's specifications chart. A fixture's listed current rating is its average current draw under normal conditions. All fixtures must be powered directly off a switched circuit and cannot be run off a rheostat (variable resistor) or dimmer circuit, even if the rheostat or dimmer channel is used solely for a 0% to 100% switch. Before applying power to a fixture, check that the source voltage matches the fixture's requirement. Check the fixture or device carefully to make sure that if a voltage selection switch exists that it is set to the correct line voltage you will use.

AC Voltage Switch

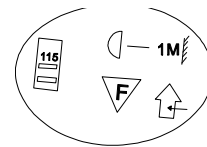

Warning!

Verify that the power select switch on your unit matches the line voltage applied. All fixtures must be connected to circuits with a suitable Earth Ground.

Safety Instructions

Please read these instructions carefully, which includes important information about the installation, usage and maintenance?

- Please keep this User Guide for future consultation. If you sell the unit to another user, be sure that they also receive this instruction booklet.
- Always make sure that you are connecting to the proper voltage and that the line voltage you are connecting to is not higher than that stated on decal or rear panel of the fixture.
- This product is intended for indoor use only!
- To prevent risk of fire or shock, do not expose fixture to rain or moisture. Make sure there are no flammable materials close to the unit while operating.
- The unit must be installed in a location with adequate ventilation, at least 50cm from adjacent surfaces. Be sure that no ventilation slots are blocked.
- Always disconnect from power source before servicing or replacing lamp or fuse and be sure to replace with same lamp source.
- Secure fixture to fastening device using a safety chain. Never carry the fixture solely by its head. Use its carrying handles.
- Maximum ambient temperature is Ta: 40°. Do not operate fixture at temperatures higher than this.
- In the event of serious operating problem, stop using the unit immediately. Never try to repair the unit by yourself. Repairs carried out by unskilled people can lead to damage or malfunction. Please contact the nearest authorized technical assistance center. Always use the same type spare parts.
- Don't connect the device to a dimmer pack.
- Make sure power cord is never crimped or damaged.
- Never disconnect power cord by pulling or tugging on the cord.
- Avoid direct eye exposure to lamp while it is on.

Caution!

There are no user serviceable parts inside the unit. Do not open the housing or attempt any repairs yourself. In the unlikely event your unit may require service, please contact CHAUVET.

INTRODUCTION

Features

- 2-4 channel DMX RGB color wash fixture
- Operating modes:
 - RGB Mode: Full RGB mix plus dimmer (4 channels)
 - C&B Mode: Color selection (40 presets) and dimmer (2 channels)
 - RGB & Chase Mode: 7 distinct operating modes (4 channels)
 - RGB mix, 8-pattern auto, 8-pattern sound, auto-chase, sound-chase, 40-color auto or sound
- Individual channel controls may include;
 - Red 0-100%, color selection or mode select
 - Green or Red 0-100%, dimmer 0-100%
 - Blue or Green 0-100%, fade time
 - Dimmer 0-100%, speed time
- 900 watts of total brightness
- Built in beat activated and automatic programs (stand-alone)
- Barn doors
- Sound sensitivity knob
- Double bracket yoke doubles as floor stand
- Linkable via Master/Slave
- Fan cooled

DMX Channel Summary

RGB Mode

Channel	Function
1	Red
2	Green
3	Blue
4	Dimmer

C&B (Color & Brightness) Mode

Channel	Function
1	Color Selection
2	Dimmer

Combined RGB & Chase Mode

Channel	Function
1	Control Mode
2	Red or Dimming
3	Green or Fade
4	Blue or Speed

For complete channel listing see DMX Values in the Appendix section.

Product Overview

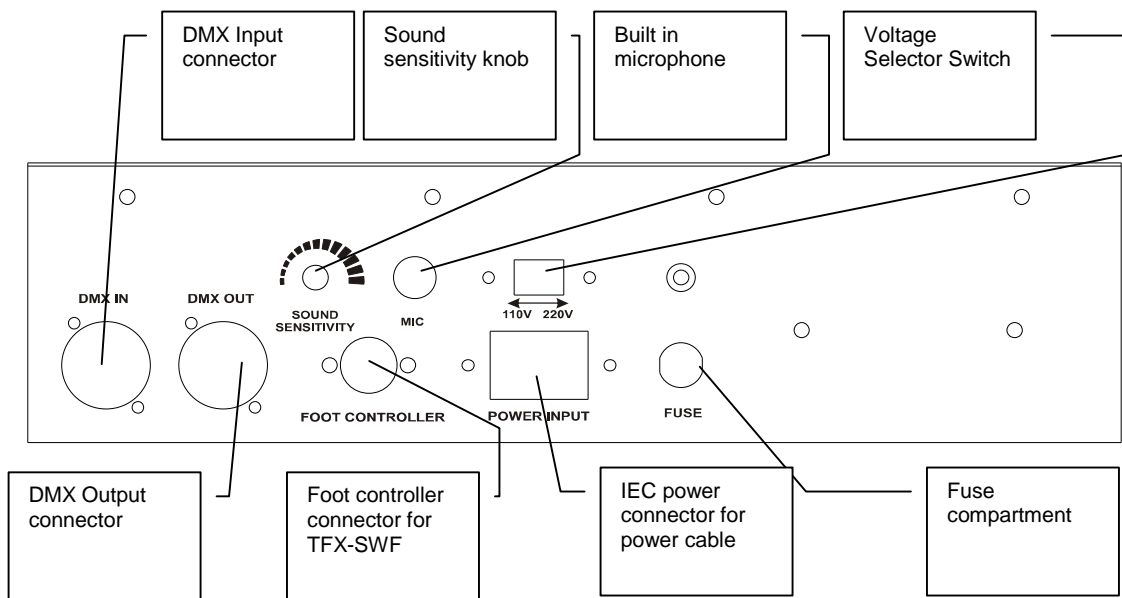
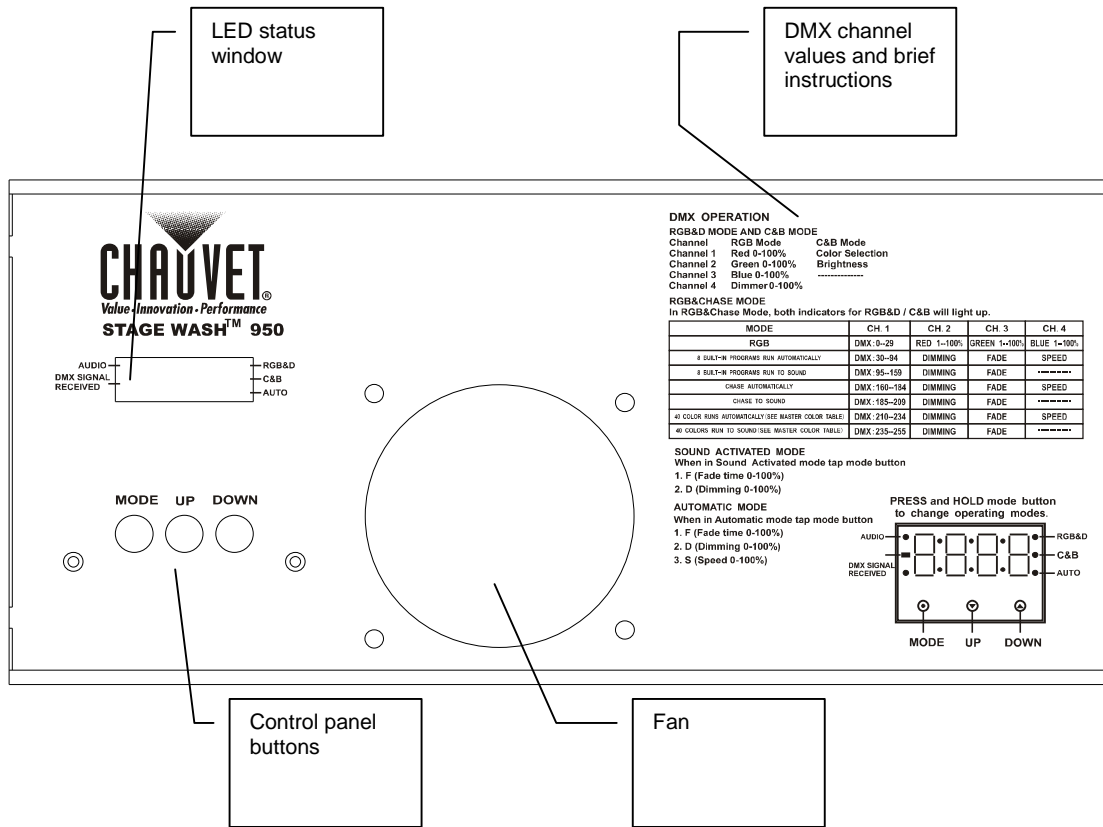

SETUP

Lamp

You will need to install a lamp prior to the initial operation of the fixture. Three EHM 300W halogen lamps are included.

Warning! *When replacing the lamp, please wait 15 minutes after powering down to allow the unit to cool down! Always disconnect from main power prior to lamp replacement.* Do not touch the envelope (glass area) of the bulb with bare hands. If this happens, clean the lamp with alcohol and wipe it with a lint free cloth before installation.

LAMP INSTALLATION

- 1) Remove the 2 screws as illustrated in Figure 3, located on the front of the fixture and lift the entire cover plate until lamp reflectors are exposed.
- 2) The linear lamp is held in place by tension provided by springs inside of both ceramic socket ends. It is important to proceed with lamp removal and replacement very delicately.
- 3) Hold linear lamp with a napkin and push in the direction of either of the two ends to relieve tension on the opposite end. Then pull end of lamp upwards to remove from socket.
- 4) To replace lamp, follow the same procedure as above to insert lamp into the socket.
- 5) Lower the cover plate and replace both screws.
- 6) No lamp alignment is necessary for this fixture.

TFX-950CM Lamp Installation

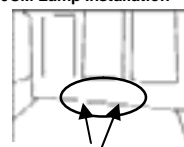

Remove these 2 screws

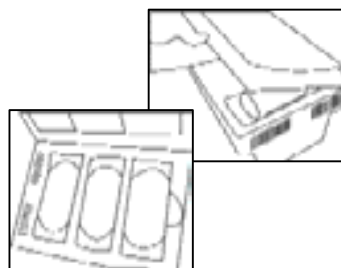

Lamps exposed

Power

Your product is equipped with switch-selectable AC power setting.

Warning! *Verify that the power select switch on your unit matches the line voltage applied. All fixtures must be connected to circuits with a suitable Earth Ground.*

Slide switch up or down depending on your line voltage.

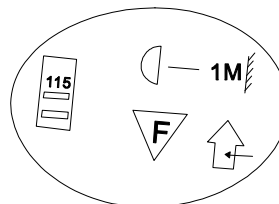

- To determine the power requirements for a particular fixture, see the label affixed to the back plate of the fixture or refer to the fixture's specifications chart.
- A fixture's listed current rating is its average current draw under normal conditions.
- All fixtures must be powered directly off a switched circuit and cannot be run off a rheostat (variable resistor) or dimmer circuit, even if the rheostat or dimmer channel is used solely for a 0% to 100% switch.
- Before applying power to a fixture, check that the source voltage matches the fixture's requirement.
- All fixtures must be connected to circuits with a suitable Earth Ground.

Mounting

ORIENTATION

This fixture may be mounted in any position provided there is adequate room for ventilation.

RIGGING

It is important never to obstruct the fan or vents pathway. Mount the fixture using a suitable “C” or “O” type clamp. Adjust the angle of the fixture by loosening both knobs and tilting the fixture. After finding the desired position, retighten both knobs.

- When selecting installation location, take into consideration lamp replacement access and routine maintenance.
- Safety cables should always be used.
- Never mount in places where the fixture will be exposed to rain, high humidity, extreme temperature changes or restricted ventilation.

Hanging Clamp



Note!
Clamp is sold separately.

DOUBLE BRACKET YOKE (FLOOR STAND)

The TFX-950CM can also be positioned on the floor using its double bracket yoke. This product gets **extremely hot** under normal operation and you should take extreme care to avoid any contact what so ever with the fixture while in use. Be sure to keep all traffic at least 4 feet away from the fixture's position.

OPERATING INSTRUCTIONS

Operating Modes

The TFX-950CM can be operated in three ways.

- A stand-alone mode will listen to sound and run through its diverse range of built in programs. An optional TFX-SWF wired controller provides simple remote control.
- Master/Slave mode will allow the command of up to as many units you want in a synchronized light show to the sound.
- DMX control mode will provide the greatest flexibility and creativity. Each fixture trait can be controlled individually using any universal DMX-512 controller.

Stand Alone Mode

The Stand Alone mode is activated by setting the TFX-950CM to either AUDIO (Sound Active) or AUTO (Automatic) mode. The built in programs consist of a color chase and depending on the mode, two or three parameters can be modified as described next.

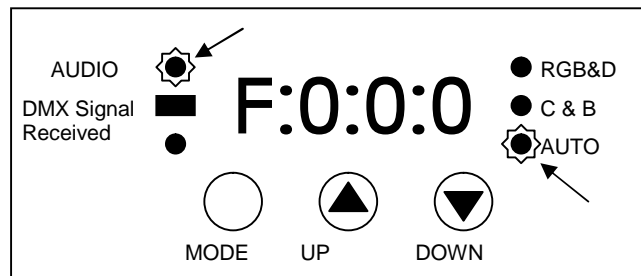

AUDIO MODE (ALSO SOUND-ACTIVE)

- 1) A steady hold of the **MODE** button will change the operating mode once then release the button.
- 2) Repeat step 1 until you arrive at the AUDIO operating mode, as indicated by the LED next to the label.
- 3) Two parameters will now become available for the AUDIO mode. Press the **MODE** button quickly to toggle between parameters.
 - **F** (for Fade time 0 ~ 100%)
 - **D** (for Dimming 0 ~ 100%)
- 4) Use the **UP** and **DOWN** buttons to change values for each respective parameter.

AUTOMATIC MODE

- 1) A steady hold of the **MODE** button will change the operating mode once then release the button.
- 2) Repeat step 1 until you arrive at the AUTO operating mode, as indicated by the LED next to the label.
- 3) Three parameters will now become available for the AUTO mode. Press the **MODE** button quickly to toggle between parameters.
 - **F** (for Fade time 0 ~ 100%)
 - **D** (for Dimming 0 ~ 100%)
 - **S** (for Speed 0 ~ 100%)
- 4) Use the **UP** and **DOWN** buttons to change values for each respective parameter.

Master/Slave

The Master/Slave mode will allow you to link up to as many units you want in a daisy chain fashion. In this mode, the first unit in the daisy chain will automatically command all other units following. An optional TFX-SWF controller connected to the first unit in the chain will allow enhanced control functions.

MASTER/SLAVE SETTINGS

- 1) Connect the (male) 3 pin connector side of the DMX cable to the output (female) 3 pin connector of the first fixture.
- 2) Connect the end of the cable coming from the first fixture which will have a (female) 3 pin connector to the input connector of the next fixture consisting of a (male) 3 pin connector. Then, proceed to connect from the output as stated above to the input of the following fixture and so on as illustrated below in figure "Daisy Chain Connection".

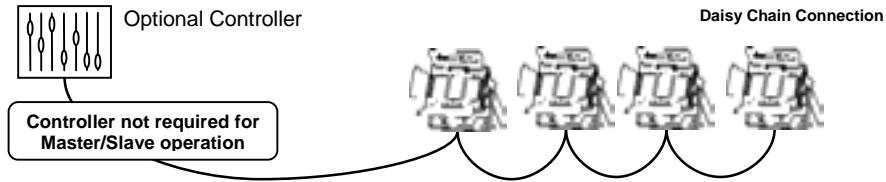

Note! For additional information on linking fixtures read under section "DMX Primer"

DMX Mode

Operating in a DMX Control mode environment gives the user the greatest flexibility when it comes to customizing or creating a show. In this mode you will be able to control each individual trait of the fixture independently.

SETTING THE STARTING ADDRESS

This DMX mode enables the use of a universal DMX controller device. Each fixture requires a "start address" from 1 to 511. A fixture requiring one or more channels for control begins to read the data on the channel indicated by the start address. For example, a fixture that occupies or uses 6 channels of DMX and was addressed to start on DMX channel 100, would read data from channels: 100, 101, 102, 103, 104, and 105. Choose start addresses so that the channels used do not overlap and notate the start address selected for future reference.

If this is your first time addressing a fixture using the DMX-512 control protocol than I suggest jumping to the Appendix Section and read the heading "DMX Primer". It contains very useful information that will help you understand its use.

There are three different DMX channel configurations on the Stage Wash. Each mode or configuration allows the user to control the fixture in a different manner using a universal DMX controller.

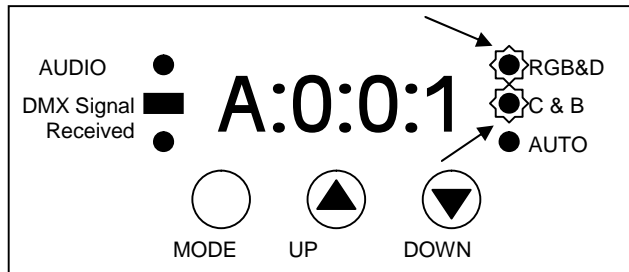

RGB&D MODE

All three lamps are individually dimmable giving the user the ability to customize or create the color of choice. This mode offers the user complete freedom.

- 1) A steady hold of the **MODE** button will change the operating mode once then release the button.
- 2) Repeat step 1 until you arrive at the **RGB&D** operating mode, as indicated by the led next to the label.
- 3) The display will now read parameter A: which represents the DMX channel address value. Use the **UP** and **DOWN** buttons to change values.

Channel	Function
1	Red
2	Green
3	Blue
4	Dimmer

C&B MODE

This is called the Color and Brightness mode. Use channel 1 to move across the RGB spectrum.

- 1) A steady hold of the **MODE** button will change the operating mode once then release the button.
- 2) Repeat step 1 until you arrive at the **C&B** operating mode, as indicated by the led next to the label.
- 3) The display will now read parameter A: which represents the DMX channel address value. Use the **UP** and **DOWN** buttons to change values.

Channel	Function
1	Spectrum Color Mix
2	Dimmer
See Color Mix Table in the appendix section.	

RGB & CHASE MODE

This is the most diverse operating mode the Stage Wash has to offer. It allows individual RGB mix control when needed while still maintaining the ability to run built in automated chase programs.

- 1) A steady hold of the **MODE** button will change the operating mode once then release the button.
- 2) Repeat step 1 until both the **RGB&D** and the **C&B** led turn on.
- 3) The display will now read parameter A: which represents the DMX channel address value. Use the **UP** and **DOWN** buttons to change values.

Channel	Function
1	Control Mode
2	Red or Dimming
3	Green or Fade
4	Blue or Speed

TFX-SWF Easy Controller (Optional)

The TFX-SWF Foot Controller is used only in master/slave mode. Connect the 8-pin connector of the foot controller into its respective connector on the first unit in the daisy chain. The table below describes the functions of the TFX-SWF Controller.

TFX-SWF BUTTONS

Stand By	Mode	Function
Blackout	Auto Led 1: Off Led 2: Off	Fixtures will run built in programs automatically
	Audio Led 1: Off Led 2: On	Fixtures will run built in programs to the sound.
	Manual Led 1: On Led 2: Off	Full/CB: Hold: pedal to set to Full On Bump: Pedal to set dimming levels
	Manual Led 1: On Led 2: On	Full/CB: Hold: pedal to set dimming levels Release: Pedal to set to Full On

TFX-SWF Foot Controller

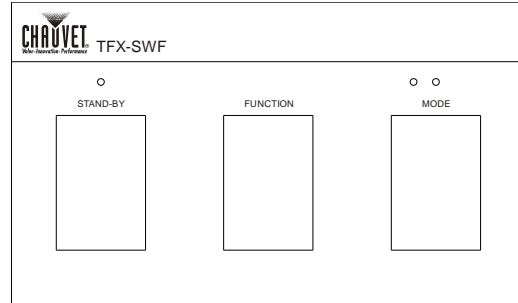

TFX-CONPK Stage Wash™ Controller Pack (Optional)

The TFX-CONPK is a package that includes the TFX-32CON which is an enhanced dedicated controller for the TFX-950CM, TFX-64CM and TFX-1550CM fixtures. The TFX-32F foot controller is also included for hands-free operation.

The TFX-32CON provides the following features:

- 9 different hold-color buttons for immediate color access
- fader access to 40 predefined mixed colors
- fade time control
- 12 different chase patterns to choose from
- chase speed control
- master dimmer level
- blackout button
- full on button
- sound button

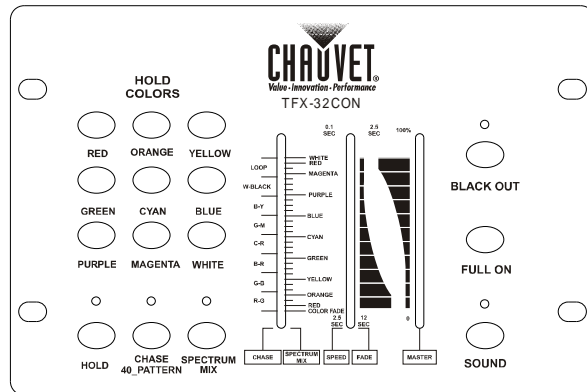

The TFX-32F provides the following features:

- Selectable modes:
1. Blackout
2. Color Hold
3. Chase
- Up and down pedal buttons select colors and chase patterns

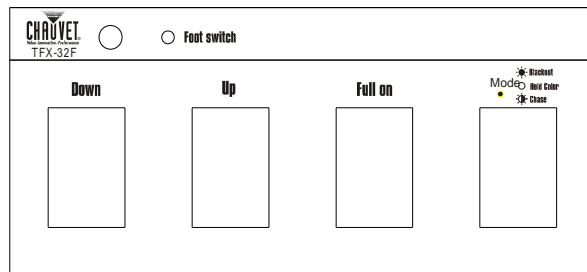

Please refer to the TFX-32CON and TFX-32F user manuals for more in depth information.

APPENDIX

DMX Primer

There are 512 channels in a DMX-512 connection. Channels may be assigned in any manner. A fixture capable of receiving DMX 512 will require one or a number of sequential channels. The user must assign a starting address on the fixture that indicates the first channel reserved in the controller. There are many different types of DMX controllable fixtures and they all may vary in the total number of channels required. Choosing a start address should be planned in advance. Channels should never overlap. If they do, this will result in erratic operation of the fixtures whose starting address is set incorrectly. You can however, control multiple fixtures of the same type using the same starting address as long as the intended result is that of unison movement or operation. In other words, the fixtures will be slaved together and all respond exactly the same.

DMX fixtures are designed to receive data through a serial Daisy Chain. A Daisy Chain connection is where the DATA OUT of one fixture connects to the DATA IN of the next fixture. The order in which the fixtures are connected is not important and has no effect on how a controller communicates to each fixture. Use an order that provides for the easiest and most direct cabling. Connect fixtures using shielded two conductor twisted pair cable with three pin XLR male to female connectors. The shield connection is pin 1, while pin 2 is Data Negative (S-) and pin 3 is Data positive (S+). CHAUVET carries 3-pin XLR DMX compliant cables, DMX-10 (33'), DMX-4.5 (15') and DMX-1.5 (5')

FIXTURE LINKING

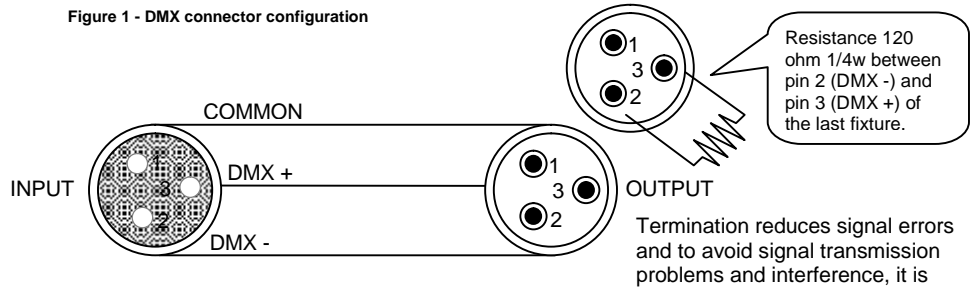

Note!

If you use a controller with a 5 pin DMX output connector, you will need to use a 5 pin to 3 pin adapter. Chauvet Model No: DMX5M. The chart below details a proper cable conversion:

3 Pin to 5 Pin Conversion Chart

Conductor	3 Pin Female (output)	5 Pin Male (Input)
Ground/Shield	Pin 1	Pin 1
Data (-)signal	Pin 2	Pin 2
Data (+) signal	Pin 3	Pin 3
Do not use		Do not use
Do not use		Do not use

DMX Channel Values

RGB&D Mode (RGB and Dimmer)

Channel	Value	Function	Notes
1	000 ⇔ 255	Red Intensity: 0% ~ 100%	
2	000 ⇔ 255	Green Intensity: 0% ~ 100%	
3	000 ⇔ 255	Blue Intensity: 0% ~ 100%	
4	000 ⇔ 255	Dimmer 0 ⇔ 100%	

C&B Mode (Color and Brightness)

Channel	Value	Function	Notes
1	000 ⇔ 255	Spectrum Color Mix See Color Mix Table	See Color Mix table on the next page
2	000 ⇔ 255	Dimmer Intensity: 0% ~ 100%	

RGB and Chase Mode

Mode	Ch 1 (Mode)	Ch 2	Ch 3	Ch 4
RGB Mode	000 ⇔ 029	Red: 0 ~ 100%	Green: 0 ~ 100%	Blue: 0 ~ 100%
8 Built-in Programs (Auto)	030 ⇔ 094	Dimming: 0 ~ 100%	Fade Time	Speed
8 Built-in Programs (Sound)	094 ⇔ 159			
Chase (Auto)	160 ⇔ 184			Speed
Chase (Sound)	185 ⇔ 209			
40 Color Chase (Auto)	210 ⇔ 234			Speed
40 Color Chase (Sound)	235 ⇔ 255			

Color Mix Table (Preset)

DMX Value	Red Intensity 0% ~ 100%	Green Intensity 0% ~ 100%	Blue Intensity 0% ~ 100%	Notes
0	0	0	0	Blackout
1	100	0	0	Red @ Full only
2	100	0	0	
3	100	3	0	Red @ Full Proportional Green
4	100	6	0	
5	100	9	0	
6	100	12	0	
7	100	15	0	
8	100	18	0	
9	100	21	0	
10	100	24	0	
11	100	27	0	
12	100	30	0	
13	100	33	0	
14	100	36	0	
15	100	39	0	
16	100	42	0	
17	100	45	0	
18	100	48	0	
19	100	51	0	
20	100	54	0	
21	100	57	0	
22	100	60	0	
23	100	63	0	
24	100	66	0	
25	100	69	0	
26	100	72	0	
27	100	75	0	
28	100	78	0	
29	100	81	0	
30	100	84	0	
31	100	87	0	
32	100	90	0	
33	100	93	0	
34	100	100	0	Red & Green @ Full
35	97	100	0	Green @ Full Proportional Red
36	94	100	0	
37	91	100	0	
38	88	100	0	
39	85	100	0	
40	82	100	0	
41	79	100	0	
42	76	100	0	
43	73	100	0	
44	70	100	0	
45	67	100	0	
46	64	100	0	
47	61	100	0	
48	58	100	0	
49	55	100	0	
50	52	100	0	
51	49	100	0	
52	46	100	0	
53	43	100	0	
54	40	100	0	
55	37	100	0	
56	34	100	0	

57	31	100	0	Green @ Full Proportional Red
58	28	100	0	
59	25	100	0	
60	22	100	0	
61	19	100	0	
62	16	100	0	
63	13	100	0	
64	10	100	0	
65	7	100	0	

66	0	100	0	Green @ Full only
67	0	100	0	
68	0	100	0	
69	0	100	0	

70	0	100	3	Green @ Full Proportional Blue
71	0	100	6	
72	0	100	9	
73	0	100	12	
74	0	100	15	
75	0	100	18	
76	0	100	21	
77	0	100	24	
78	0	100	27	
79	0	100	30	
80	0	100	33	
81	0	100	36	
82	0	100	39	
83	0	100	42	
84	0	100	45	
85	0	100	48	
86	0	100	51	
87	0	100	54	
88	0	100	57	
89	0	100	60	
90	0	100	63	
91	0	100	66	
92	0	100	69	
93	0	100	72	
94	0	100	75	
95	0	100	78	
96	0	100	81	
97	0	100	84	
98	0	100	87	
99	0	100	90	
100	0	100	93	

101	0	100	100	Green & Blue @ Full
-----	---	-----	-----	---------------------

102	0	97	100	Blue @ Full Proportional Green
103	0	94	100	
104	0	91	100	
105	0	88	100	
106	0	85	100	
107	0	82	100	
108	0	79	100	
109	0	76	100	
110	0	73	100	
111	0	70	100	
112	0	67	100	
113	0	64	100	
114	0	61	100	
115	0	58	100	
116	0	55	100	
117	0	52	100	
118	0	49	100	

119	0	46	100	Blue @ Full Proportional Green
120	0	43	100	
121	0	40	100	
122	0	37	100	
123	0	34	100	
124	0	31	100	
125	0	28	100	
126	0	25	100	
127	0	22	100	
128	0	19	100	
129	0	16	100	
130	0	13	100	
131	0	10	100	
132	0	7	100	

133	0	0	100	Blue @ Full only
134	0	0	100	
135	0	0	100	
136	0	0	100	

137	3	0	100	Blue @ Full Proportional Red
138	6	0	100	
139	9	0	100	
140	12	0	100	
141	15	0	100	
142	18	0	100	
143	21	0	100	
144	24	0	100	
145	27	0	100	
146	30	0	100	
147	33	0	100	
148	36	0	100	
149	39	0	100	
150	42	0	100	
151	45	0	100	
152	48	0	100	
153	51	0	100	
154	54	0	100	
155	57	0	100	
156	60	0	100	
157	63	0	100	
158	66	0	100	
159	69	0	100	
160	72	0	100	
161	75	0	100	
162	78	0	100	
163	81	0	100	
164	84	0	100	
165	87	0	100	
166	90	0	100	
167	93	0	100	

168	100	0	100	Red & Blue @ Full
-----	-----	---	-----	-------------------

169	100	0	97	Red @ Full Proportional Blue
170	100	0	94	
171	100	0	91	
172	100	0	88	
173	100	0	85	
174	100	0	82	
175	100	0	79	
176	100	0	76	
177	100	0	73	
178	100	0	70	
179	100	0	67	
180	100	0	64	

181	100	0	61	Red @ Full Proportional Blue
182	100	0	58	
183	100	0	55	
184	100	0	52	
185	100	0	49	
186	100	0	46	
187	100	0	43	
188	100	0	40	
189	100	0	37	
190	100	0	34	
191	100	0	31	
192	100	0	28	
193	100	0	25	
194	100	0	22	
195	100	0	19	
196	100	0	16	
197	100	0	13	
198	100	0	10	
199	100	0	7	
200	100	6	12	Red @ Full Proportional Green and Blue
201	100	12	24	
202	100	18	36	
203	100	24	48	
204	100	30	60	
205	100	36	72	
206	100	42	84	
207	100	50	100	Red & Blue @ Full, Green @ 50%
208	88	62	100	Blue @ Full Proportional Red and Green
209	76	74	100	
210	64	86	100	
211	50	100	100	Green & Blue @ Full, Red @ 50%
212	44	100	88	Green @ Full Proportional Red and Blue
213	38	100	76	
214	32	100	64	
215	26	100	52	
216	19	100	44	
217	13	100	38	
218	7	100	32	
219	12	100	25	
220	18	100	19	
221	24	100	13	
222	30	100	7	
223	38	100	12	
224	44	100	18	
225	50	100	24	
226	62	100	31	
227	74	100	37	
228	86	100	43	
229	100	100	50	Red and Green @ Full, Blue @ 50%
230	100	88	62	Red @ Full Proportional Green and Blue
231	100	76	74	
232	100	64	86	
233	100	50	100	Red and Blue @ Full, Green @ 50%

234	88	44	100	Blue @ Full Proportional Red and Green
235	76	38	100	
236	64	32	100	
237	50	25	100	
238	44	19	100	
239	38	13	100	
240	32	7	100	
241	25	12	100	
242	19	18	100	
243	13	24	100	
244	7	30	100	
245	12	36	100	
246	18	42	100	
247	24	48	100	
248	31	62	100	
249	37	74	100	
250	43	86	100	
251	49	98	100	
252	62	100	100	Blue and Green @ Full Proportional Red
253	74	100	100	
254	86	100	100	
255	100	100	100	Red,Green,Blue @ FULL (White)

Maintenance

To maintain optimum performance and minimize wear fixtures should be cleaned frequently. Usage and environment are contributing factors in determining frequency. As a general rule, fixtures should be cleaned at least twice a month. Dust build up reduces light output performance and can cause overheating. This can lead to reduced lamp life and increased mechanical wear. Be sure to power off fixture before conducting maintenance.

Unplug fixture from power. Use a vacuum or air compressor and a soft brush to remove dust collected on external vents and internal components. Clean all glass when the fixture is cold with a mild solution of glass cleaner or Isopropyl Alcohol and a soft lint free cotton cloth or lens tissue. Apply solution to the cloth or tissue and drag dirt and grime to the outside of the lens. Gently polish optical surfaces until they are free of haze and lint. Do not touch the lamp glass when cleaning fixture. Oil and dirt can cause damage and premature aging of the lamp. In the event that the lamp is touched or becomes dirty, clean the lamps with an alcohol wipe.

The cleaning of internal and external optical lenses and/or mirrors must be carried out periodically to optimize light output. Cleaning frequency depends on the environment in which the fixture operates: damp, smoky or particularly dirty surrounding can cause greater accumulation of dirt on the unit's optics. Clean with soft cloth using normal glass cleaning fluid. - Always dry the parts carefully. - Clean the external optics at least every 20 days. Clean the internal optics at least every 30/60 days.

Returns Procedure

Returned merchandise must be sent prepaid and in the original packing, call tags will not be issued. Package must be clearly labeled with a Return Merchandise Authorization Number (RA #). Products returned without an RA # will be refused. Call CHAUVET and request RA # prior to shipping the fixture. Be prepared to provide the model number, serial number and a brief description of the cause for the return. Be sure to properly pack fixture, any shipping damage resulting from inadequate packaging is the customer's responsibility. CHAUVET reserves the right to use its own discretion to repair or replace product(s). As a suggestion, proper UPS packing or double-boxing is always a safe method to use.

Claims

Damage incurred in shipping is the responsibility of the shipper; therefore the damage must be reported to the carrier upon receipt of merchandise. It is the customer's responsibility to notify and submit claims with the shipper in the event that a fixture is damaged due to shipping. Any other claim for items such as missing component/part, damage not related to shipping, and concealed damage, must be made within seven (7) days of receiving merchandise.

General Troubleshooting

Symptom	Solution(s)	Applies to			
		Lights	Foggers & Snow	Controllers	Dimmers & Chaser
Auto shut off	Check fan thermal switch reset	✓			
Beam is very dim or not bright	Clean optical system or replace lamp Check 220/110v switch for proper setting	✓			
Breaker/Fuse keeps blowing	Check total load placed on device				✓
Chase is too slow	Check users manual for speed adjustment	✓		✓	✓
Device has no power	Check for power on Mains. Check device's fuse. (internal and/or external)	✓		✓	✓
Fixture is not responding	Check DMX Dip switch settings for correct addressing Check DMX cables Check polarity switch settings	✓			
Fixture is on but there is no movement to the audio	Make sure you have the correct audio mode on the control switches. If audio provided via ¼" jack, make sure a live audio signal exists Adjust sound sensitivity knob	✓		✓	✓
Lamps cuts off sporadically	Possible bad lamp or fixture is overheating. Lamp may be at end of its life.	✓			
Light will not come on after power failure	Some discharge lamps require a cooling off period before the electronics in the fixture can kick start it again, wait 5 to 10 minutes before powering up	✓			
Loss of signal	Use only DMX cables Install terminator Note: Keep DMX cables separated from power cables or black lights.	✓	✓	✓	✓
Moves slow	Check 220/110v switch for proper setting	✓			
No flash	Re-install bulb, may have shifted in shipping	✓			
No laser output	Bounce mirror motor may have shifted during shipping, readjust	✓			
No light output	Check slip ring & brushes for contact Install bulb Call service technician	✓			
Relay will not work	Check reset switch Check cable connections				✓
Remote does not work	Make sure connector is firmly connected to device	✓	✓		
Stand alone mode	All Chauvet lighting fixtures featuring stand-alone functions do not require additional settings, simply power the fixture and it will automatically enter into this mode	✓			

Technical Specifications

WEIGHT & DIMENSIONS

Length.....	305 mm (12 in)
Width.....	229 mm (9 in)
Height	152 mm (6 in)
Weight.....	5.9 Kg (13.2 lbs)

POWER

Switch-selectable power settings.....	115V 60 Hz or 230V 50 Hz
European version.....	240V 50 Hz
AC input.....	3-prong IEC 60320 C14

LAMPS

3 x EHM (115V).....	2,000 hr, 300W
3 x EHM2 (230V)	2,000 hr, 300W

THERMAL

Maximum ambient temperature.....	40° (104° F)
----------------------------------	--------------

FUSE

Main.....	30mm Glass 10A 125V Fast Blow
PCB	20mm Glass 2A Fast Blow

CONTROL & PROGRAMMING

Data input	locking 3-pin XLR male socket
Data output	locking 3-pin XLR female socket
Data pin configuration	pin 1 shield, pin 2 (-), pin 3 (+)
Protocols.....	DMX-512 USITT
DMX Channels.....	2 to 4

ORDERING INFORMATION

Stage Wash™ 950	TFX-950CM
Stage Wash™ Controller Pack.....	TFX-CONPK
CA-32F Colormix foot Controller.....	TFX-SWF
Fuse 2A	P170FUSE002
Fuse 10A	P170FUSE010