

# Hardware Installation Guide

Revision2.1



# Preface

## **Copyright 2003**

All rights Reserved- Printed in Taiwan

## **Notice**

We make no warranties with respect to this documentation either express or implied and provide it "as it". This includes but is not limited to any implied warranties of merchantability and fitness for a particular purpose. The information in this document is subject to change without notice. We assume no responsibility for any errors that may appear in this document.

The manufacturer shall not be liable for any damage, or for the loss of information resulting from the performance or use of the information contained herein

## **Trademarks**

Product names used herein are for identification purposes only and may be the trademarks of their respective companies. All trademarks or registered trademarks are properties of their respective owners.

### Regulatory information



For Europe

This drive is in conformity with the EMC directive.



Federal Communications Commission (FCC) Statement

This equipment has been tested and found to comply with the limits for a Class A digital device, pursuant to part 15 of the FCC Rules.

Those limits are designed to provide reasonable protection against harmful interference in a residential installation. This equipment generates, uses and can radiate radio frequency energy and, if not installed and used in accordance with the instructions, may cause harmful interference to radio communications. However, there is no guarantee that interference will not occur in a particular installation. If this equipment does cause harmful interference to radio or television reception, which can be determined by turning the equipment off and on, the user is encouraged to try to correct the interference by one or more of the following measures:

Reorient or relocate the receiving antennas.

Increase the separation between the equipment and receiver.

Connect the equipment into an outlet on a circlet different from that to which the receiver is connected.

Consult the dealer or an experienced radio/TV technician for help.

Warning:

A shielded-type power cord is required in order to meet FCC emission limits and also to prevent interference to the nearby radio and television reception. It is essential that only the supplied power cord be used.

Use only shielded cables to connect I/O devices to this equipment.

You are cautioned that changes or modifications not expressly approved by the party responsible for compliance could void your authority to operate the equipment.

## General Safety Guidelines



DO NOT place the RAID SYSTEM on uneven or unstable work surfaces. Seek servicing if the casing has been damaged.

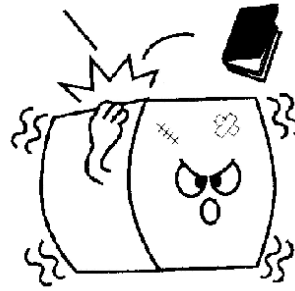

DO NOT place or drop objects on top of the RAID SYSTEM and do not shove any foreign object into it.



DO NOT expose RAID SYSTEM to liquids, rain, or moisture.

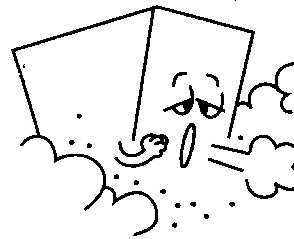

DO NOT expose RAID SYSTEM to dirty or dusty environments.



DO NOT expose RAID SYSTEM to magnetic field.

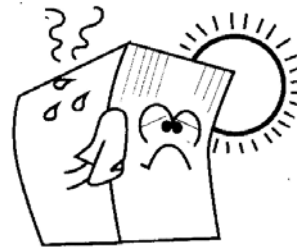

DO NOT expose RAID SYSTEM to extreme temperatures (below 5°C or above 45°C) or to direct sunlight.

### About your User's Guide

Welcome to your Hardware Installation Guide. This manual covers everything you need to know in learning how to install your RAID system. This manual also assumes that you know the basic concepts of RAID technology. For the detail about how to configure your RAID system, please refer to the RAID system Software Operation manual.

### Guide to conventions

Important information that users should be aware of is indicated with the following icons:



#### Caution

*This icon indicates the existence of a potential hazard that could result in personal injury, damage to your equipment or loss of data if the safety instruction is not observed.*



#### Note

*This icon indicates useful tips on getting the most from your RAID controller.*

Important terms, commands and programs are put in **Boldface** font.

Screen text is given in **screen** font.

# Table of Contents

<b>PREFACE</b> .....	<b>1</b>
COPYRIGHT 2003.....	1
NOTICE.....	1
TRADEMARKS.....	1
REGULATORY INFORMATION.....	2
GENERAL SAFETY GUIDELINES.....	3
ABOUT YOUR USER'S GUIDE.....	4
GUIDE TO CONVENTIONS.....	4
<b>TABLE OF CONTENTS</b> .....	<b>5</b>
<b>CHAPTER 1</b> .....	<b>7</b>
<b>CHAPTER 1</b> .....	<b>7</b>
<b>INTRODUCTION</b> .....	<b>7</b>
FEATURE HIGHLIGHT.....	7
BEFORE YOU BEGIN.....	8
<i>Unpacking &amp; Checking The Equipment</i> .....	8
<i>What else you need</i> .....	9
IDENTIFYING PARTS OF THE RAID SYSTEM.....	10
<i>Front View</i> .....	10
<i>Rear View</i> .....	15
SPACE REQUIREMENT.....	18
SYSTEM CONNECTION.....	18
<i>Cable</i> .....	18
<i>RAID system</i> .....	18
<i>Device</i> .....	18
<i>Purpose</i> .....	18
INSTALL HARD DISKS.....	19
<b>CHAPTER 2</b> .....	<b>20</b>
<b>HARDWARE INSTALLATION</b> .....	<b>20</b>

REPLACE THE CONTROLLER .....	20
REPLACING / UPGRADING SODIMM.....	24
<i>SODIMM specifications: (Applied on PA-08/BR-8000, SA-16/PA-16, &amp;.....</i>	<i>24</i>
<i>BR-1200/BR-1600).....</i>	<i>24</i>
<i>Architecture of supported SODIMM:.....</i>	<i>25</i>
<i>SODIMM specifications:(Applied on PA-08P/SA-08P, PA-16P/SA-16P).....</i>	<i>26</i>
<i>Architecture of supported SODIMM:.....</i>	<i>26</i>
<i>Installing SODIMM.....</i>	<i>27</i>
HOT SWAPPING TO REPLACE THE FAN MODULE .....	28
HOT SWAPPING TO REPLACE THE POWER MODULE .....	29
TURNING ON FOR THE FIRST TIME.....	30
TURNING OFF.....	30
RESTARTING.....	30
<b>APPENDIX A.....</b>	<b>31</b>
<b>TROUBLE SHOOTING .....</b>	<b>31</b>
<b>APPENDIX B.....</b>	<b>35</b>
<b>CONNECTORS.....</b>	<b>35</b>
<b>APPENDIX C.....</b>	<b>37</b>
<b>SPECIFICATIONS .....</b>	<b>37</b>



*Chapter 1***Introduction**

This chapter introduces the features and capabilities of RAID SYSTEM.

You will find:

- ⇒ **A full introduction to your RAID SYSTEM**
- ⇒ **Details of key features and supplied accessories**
- ⇒ **A checklist of package contents**
- ⇒ **A checklist of what else you need to start installation**

**Feature Highlight**

The RAID SYSTEM is designed to meet today's high volume, performance storage requirements from rapidly changing business environment. It provides a maximum data protection and exceptional performance in a storage subsystem. Target usage ranges are set from small business to departmental and corporate server needs. The RAID SYSTEM is designed for easy integration, smooth data expansion and server migration.

The RAID SYSTEM supports the following features:

- \* Host System independent
- \* Operating System independent
- \* High performance processor
- \* Superior Array Management Firmware
- \* Advanced PCI bus architecture
- \* Flexible cache size of up to 512MB/1GB
- \* Support for RAID Levels 0, 1,3, 5,30,50 and 0+1
- \* Dual Ultra-160 /Ultra-320 SCSI Host Interconnect support by SCSI to ATA model
- \* Dual Loop of 2Gb/sec Fibre Channel support by Fibre to ATA model
- \* Redundant and Hot Swappable Fan, Power and Drives.
- \* Hot Swap, Hot Spare and Automatic Drive Rebuild Support
- \* Programmable Page and FAX event notification

- \* Remote monitoring through terminal
- \* Load-sharing hot swappable redundant power system with PFC function .

## Before you begin

### Unpacking & Checking The Equipment

Before unpacking the RAID SYSTEM, prepare a clean, stable surface to put on the contents of your RAID SYSTEM shipping container. Altogether, you should find the following items in the package:

#### SCSI to ATA RAID System

- RAID System x1
- RAID system Hardware Installation Guide x1 (CD media or Hard Copy)
- RAID system Software Operation Manual x1 (CD media or Hard Copy)
- Ultra320 SCSI Cable x1
- RS232 cable x1
- Ultra320 SCSI Active Terminator x1
- Power Cord x1
- Mounting screws (bag) ×1

#### Fibre to ATA RAID system

- RAID System x1
- RAID system Hardware Installation Guide x1 (CD media or Hard Copy)
- RAID system Software Operation Manual x1 (CD media or Hard Copy)
- RS232 cable x1
- Power Cord x1
- Mounting screws (bag) ×1

**Note**

*To avoid the unmatched cable between the Fibre HBA in the Host and Fibre-ATA RAID SYSTEM, Fibre-ATA RAID system doesn't include the Fibre interface with the standard configuration. There are many different kinds of Fibre connectors on varied of Fibre HBAs.*

**What else you need**

- Hard disk drives (different RAID levels requires different numbers of HDDs. Refer to Software Operation manual for more detail information.)
- Host computer with SCSI interface (**SCSI-ATA RAID SYSTEM**)
- Host computer with Fibre interface (**Fibre-ATA RAID SYSTEM**)
- Static grounding strap or electrostatic discharge (ESD) safe work area
- Dedicated terminal or PC with third party communication software that supports ANSI terminal emulation (required for viewing Monitor Utility)

**Note**

*The hard drives in a RAID system should match in size and speed. All drives in any array should be identical models with the same firmware versions. RAID system can use any size drive, however the smallest drive will determine the size of the array.*

**Note**

*There's no set formula to determine how much cache memory to use, but as a general rule, a workstation, with mostly very large files, such as for audio or video editing and playback, graphics or CAD files, can benefit from a large cache. File servers, with multiple random access of varying file size, generally have little or no performance improvement with additional cache.*

**Note**

*RAID system do not require the installation of different drivers for use with different operating systems. RAID system is independent and transparent to the host operating system.*

## Identifying Parts Of The RAID system

The illustrations below identify the various parts of the RAID SYSTEM. Get yourself to familiar with these terms as it will help you when you read further in the following sections :

### Front View

**SA-16/SA-16P/PA-16/PA-16P**

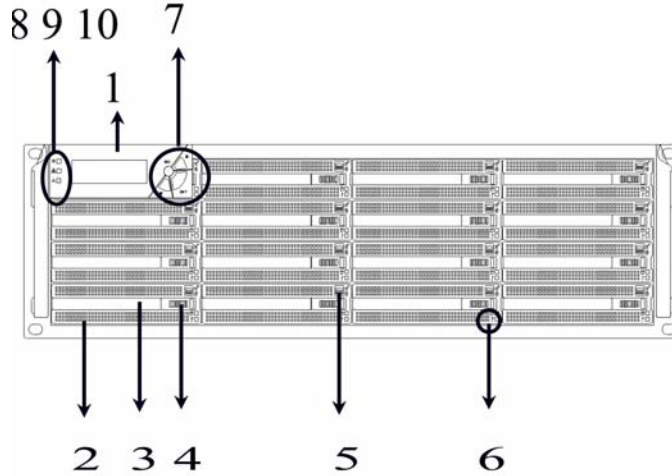

**PA-08/PA-08P/SA-08P**

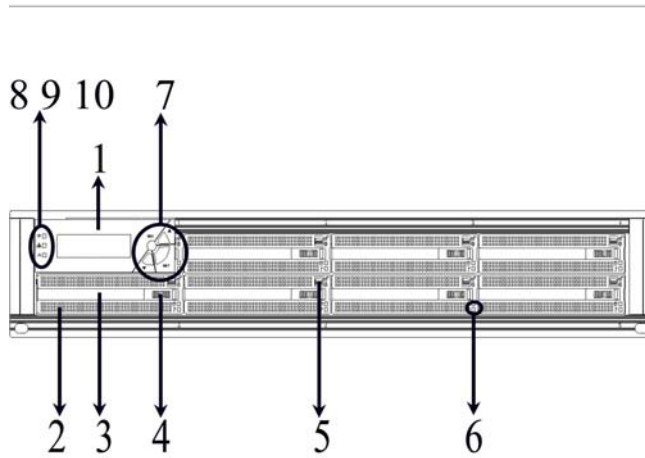

**BR-1600-R**

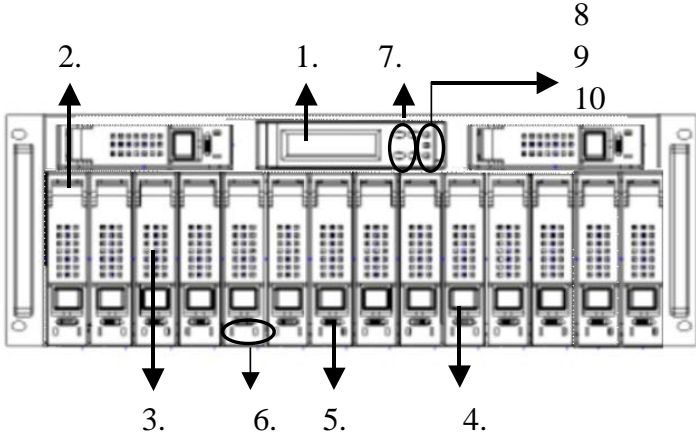

**BR-1600-D**

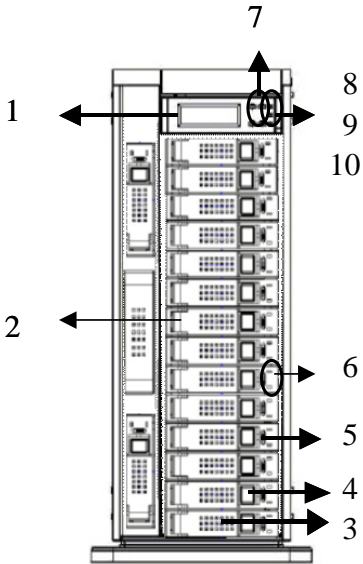

# Hardware Installation Guide

## BR-1200-R

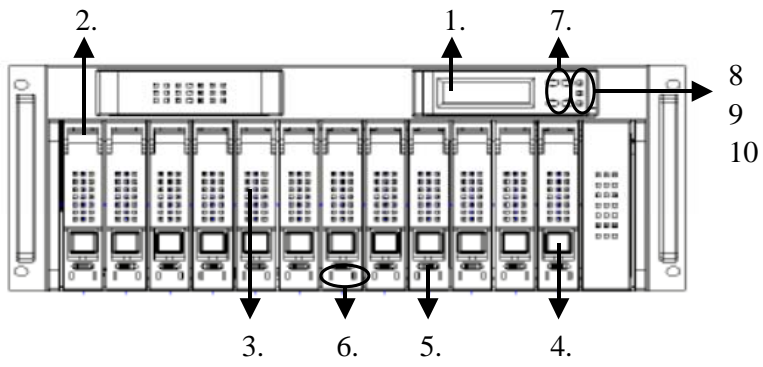

## BR-1200-D

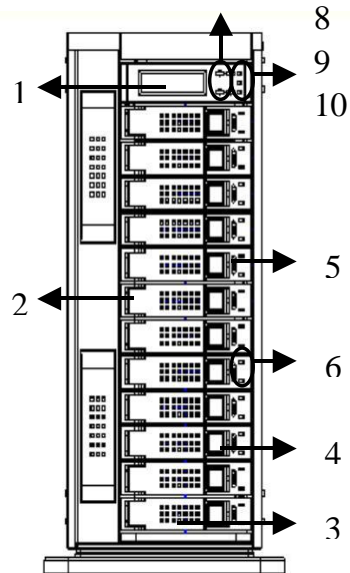

**BR-8000-R**



**BR-8000-D**



- 1. LCD Display Panel.



The front panel LCD continuously displays the status of the RAID SYSTEM. The following is an example of the RAID SYSTEM

- 2. Disk Cartridge
- 3. Cartridge Handle
- 4. Release-Button

## Hardware Installation Guide

---

5. Latch

LOCK	
UNLOCK	

6. HDD status LED Indicator

LED	Colors	Indicate
	Blue or Green	HDD On Line
	Blue + Blink or Amber	HDD Access
?	Red	HDD Error

7. Function keys. ( ENT , ESC, Scroll up , Scroll Down )

Keys	Descriptions
Up Arrow	To scroll upward through the menu items
Down Arrow	To scroll downward through the menu items
(ENT) Enter	To confirm a selected item
(ESC) ESC	To exit a sub-menu and return to previous menu.

8.  Power On Indicator (Blue or Green).

9.  Power Fail Indicator (Red)

10.  Host System Access Indicator (Blue + blink or Yellow).



Rear View

SA-16U3/SA-16U4P/PA-16U4P

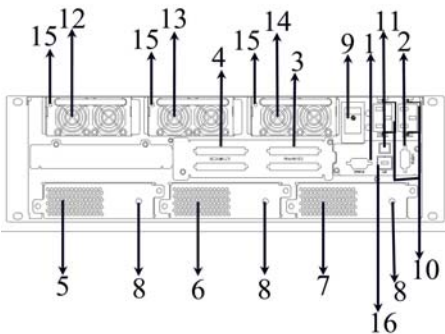

SA-16FC/SA-16FCP/PA-16U4P

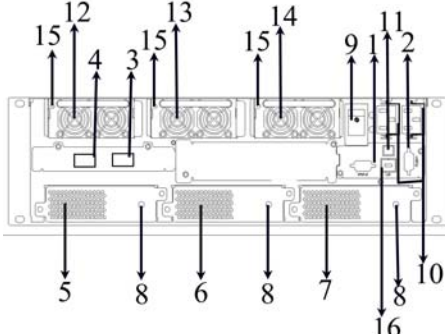

PA-16U3

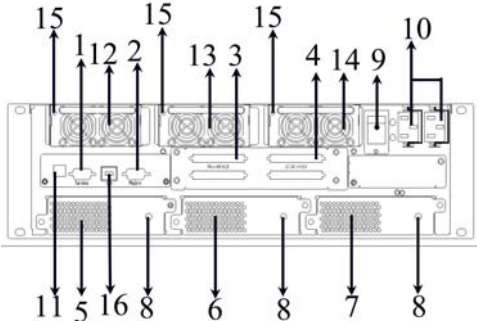

PA-16FC

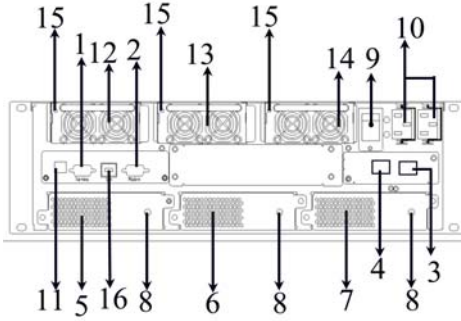

PA-08U3/PA-08U4P/SA-08U3/SA-08U4P

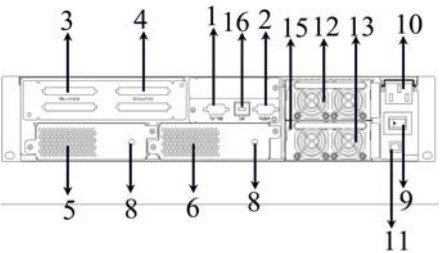

PA-08FC/PA-08FCP/SA-08FC/SA-08FCP

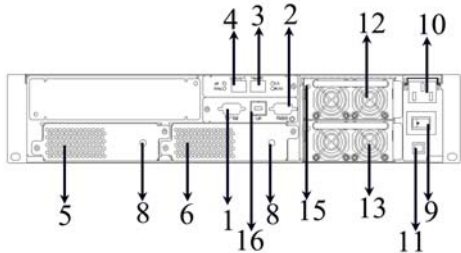

# Hardware Installation Guide

BR-1200/1600

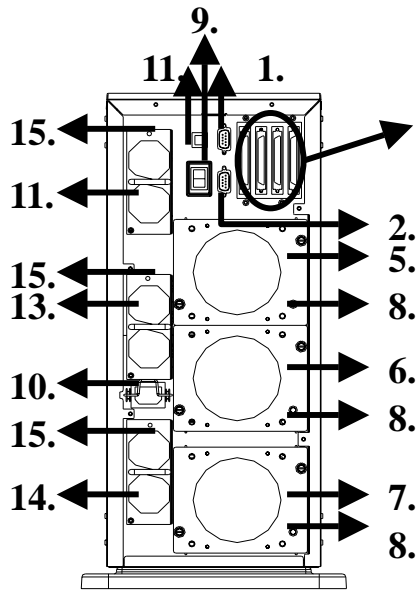

BR-8000D

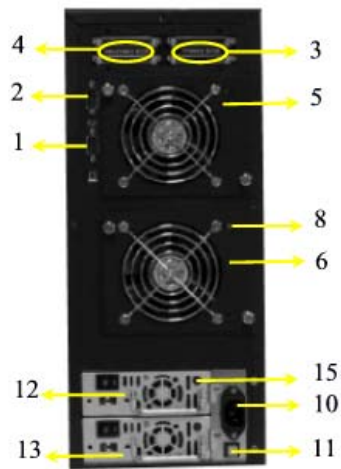
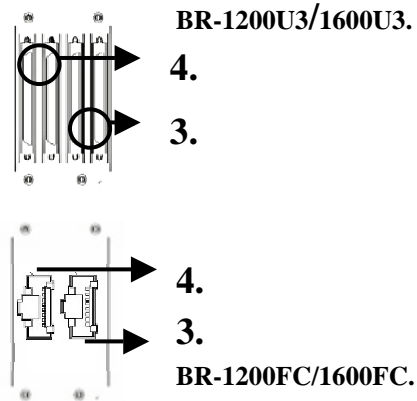

BR-8000U3.

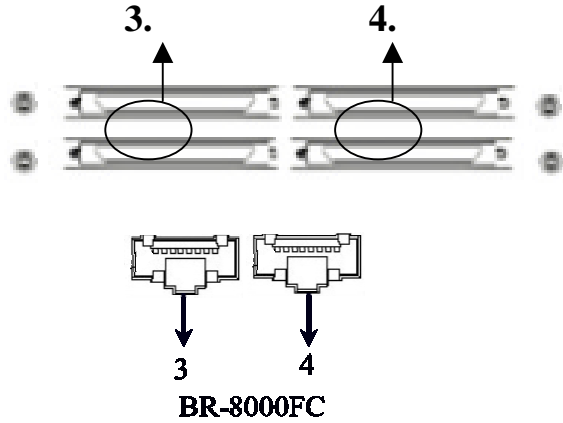

BR-8000R

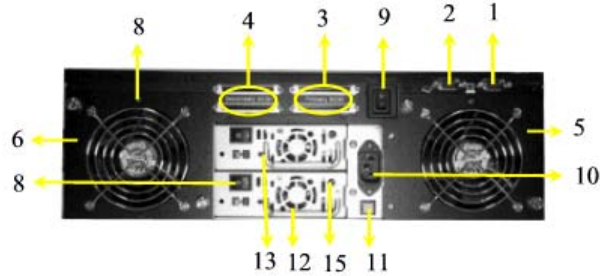

- 1. RS232 Port (For Terminal)
- 2. Modem Port
- SCSI-ATA RAID SYSTEM:
  - 3. Primary Host SCSI Channel Port
  - 4. Second Host SCSI Channel Port
- Fibre-ATA RAID SYSTEM:
  - 3. 1<sup>st</sup> Fibre Channel Loop
  - 4. 2<sup>nd</sup> Fibre Channel Loop
- 5. System Cooling Module 1.
- 6. System Cooling Module 2.
- 7. System Cooling Module 3.
- 8. System Cooling Module Fail Indicator.
- 9. Power Switch
- 10. AC Inlet with the Latch
- 11. Power Supply “Alarm” Reset Button.
- 12. Power Module 1.
- 13. Power Module 2.
- 14. Power Module 3.
- 15. Power Indicator LED on Module.
- 16. LAN Port

### Space Requirement

When selecting a location for your system, be sure to allow an adequate space. The system has vents around it which will require a minimum of 3 inches of unobstructed space for airflow. Openings in the equipment should be blocked, or there may be an issue of reliability problems with your system. A system product should never be placed around a radiator or heat register.

### System Connection

Connect all cables and power cord as shown below:

Cable	RAID system	Device	Purpose
RS-232 cable	RS-232 Port	ANSI Terminal or a PC with Hyper terminal	Terminal Utility for configuration and Monitoring
SCSI Cable / Fibre cable	Primary SCSI/FC-AL or Secondary SCSI/FC-AL	SCSI/FC-AL HBA of Host Computer	Host Interface
Power Cord	Power Inlet	A/C Power Outlet	A/C power input
RS-232 cable	Modem Port	Modem	Event notification via Fax and page



#### Note

*Make sure that all the devices are powered off before connecting or removing cables to prevent power spikes which can damage technical components.*

## Install hard disks

The RAID SYSTEM includes 8/12/16 ( depending on your models) removable disk cartridges.

The following sections describe how to install disks into RAID SYSTEM subsystems.

### Remove Cartridges

Slide the latch to unlock.

Release the handle by sliding lift the release button.

Lift the handle to disengage the disk cartridge from the slot.



### Install HDDs.

Put HDD into the Cartridge.

Skip this procedure if you are using SATA HDDs. Connect the flat cable to the HDD. Make sure pin1 (also designated by the color strip) of the cable is aligned with pin1 of disk connector.

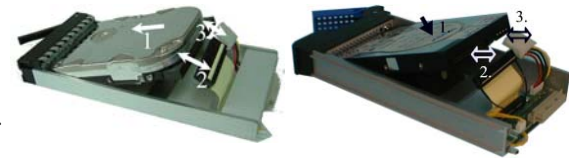

Skip this procedure if you are using SATA HDDs. Connect the power cable to the power connector of HDD.

Fasten all 4 screws to mount HDD in the cartridge and make sure the HDD is properly tightened.

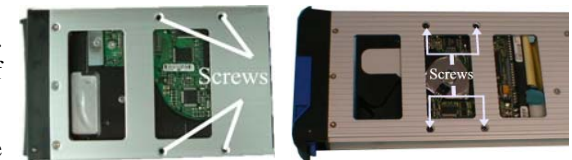

### Install Cartridges

Reversed the procedures of “Remove cartridges” to install cartridges back to RAID system .

Chapter 2

# Hardware Installation

This chapter presents:

- ⇒ **Instructions on replacing components**
- ⇒ **Instructions on replacing the hot swappable components**
- ⇒ **Instructions on how to install and upgrade DRAM**

## Replace the Controller



### Caution

*Read the replacing notices earlier in this chapter before proceeding with replacement.*

This section provides instructions for the removal and installation of the RAID controller components indicated in the figure below. This section is for the reference of engineers. End users should not need to replace or remove components.

Removing the controller from PA-08/PA-16/SA-16:

Unscrew the Fasteners of Bracket then slide it back.

Disconnect the host cables.

Turn anti-clock wise to release the thumb screw.

Use the eject kit to remove controller board.

PA-08/SA-08/SA-08P



PA-16

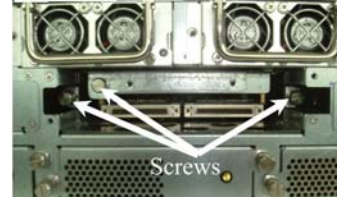
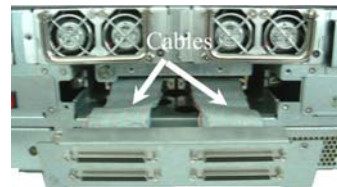

SA-16/SA-16P/PA-16P

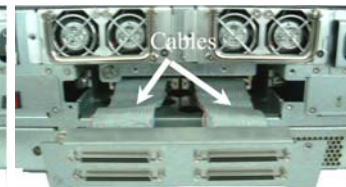

Installing the controller into PA/08/PA-16/SA-16:

Reverse the procedures as above to install the controller into SA-16/PA-16.

Then according to “Appendix C. Configuration table” on “Soft Operation Manual” to reconfigure your RAID

## Hardware Installation Guide

---

### Removing the controller from BR-8000D/R :

In order to access internal components, remove the controller box cover by unscrew the fasteners of the cover and then slide it back and lift it off.

Disconnect the host cables, then unscrew four fasteners on the controller and lift upward to remove it.

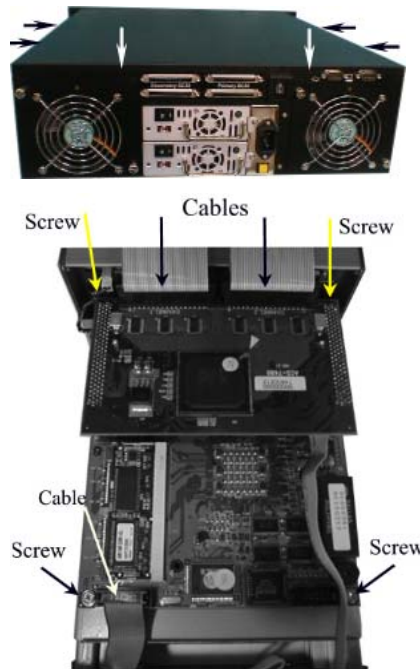
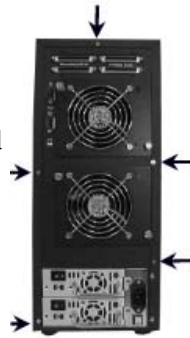

### Installing the controller into BR-8000D/R :

Reverse the procedure of “**removing the controller**” to install the controller into BR-8000.

Then according to “Appendix C. Configuration table” on “Soft Operation Manual” to reconfigure your RAID



Removing the controller from BR-1200 & BR-1600:

Remove the Fan modules by anti-clock wise to release the thumb screws then slide it back and lift it off.

Unscrew the two fasteners on the bracket and backward to remove the bracket

Disconnect the host cables

Turn anti-clock wise to release the thumb screw, then use the eject kit to remove controller board

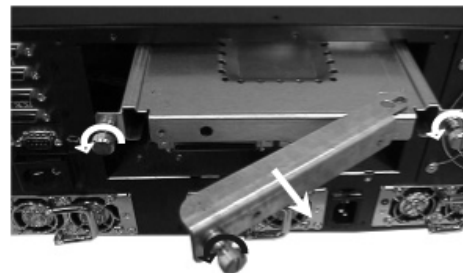
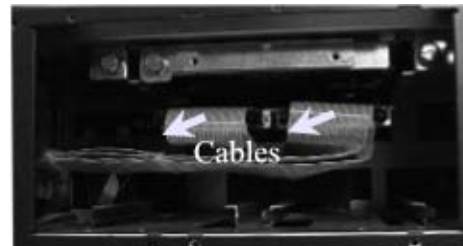
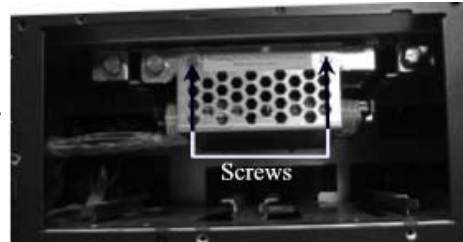

Installing the controller into BR-1200/1600 :

Reverse the procedures as above to install the controller into BR-1200/BR-1600.

Then according to “Appendix C. Configuration table” on “Soft Operation Manual” to reconfigure your RAID

## Replacing / Upgrading SODIMM



### Caution

*Read the pre-installation notices earlier in this chapter before proceeding with installation.*

RAID SYSTEM is normally supplied with 64MB (PA-08/BR-8000) and 128MB (SA-16/PA-16/BR-1200/BR1600) DRAM installed.



### Note

*There's no set formula to determine how much cache memory to use, but as a general rule, a workstation, with mostly very large files, such as for audio or video editing and playback, graphics or CAD files, can benefit from a large cache. File servers, with multiple random access of varying file size, generally have little or no performance improvement with additional cache.*

### SODIMM specifications: (Applied on PA-08/BR-8000, SA-16/PA-16, &

#### BR-1200/BR-1600)

Minimum	Recommended
■ 144-pin SDRAM SODIMM module (PC-100, 60~80 ns).	■ SDRAM
■ SODIMM, without parity	■
■ Minimum of one SODIMM with 32 MB. The memory card socket can support 32, 64, 128, 256 or 512 MB of memory.	■ Minimum of 32 MB. More memory (up to 512MB) equals better performance: the size of the memory module defines the cache writing space available to the RAID SYSTEM.

**Note**

*The RAID system controller board already implement a 512Mb memory for the propose of Parity bit to support the ECC feature. There is no need to install the SODIMM with parity.*

**Architecture of supported SODIMM:****SDRAM Architecture**

■ 512 MB	■ 16 (32M x 8)
■ 256 MB	■ 16 (16M x 8), 8 (32M x 8) <b>or</b> ■ 8 (16M x 16)
■ 128 MB	■ 16 (8M x 8), 8 (16M x 8), 8 (8M x 16) <b>or</b> ■ 4 (16M x 16)
■ 64 MB	■ 8 (8M x 8), 8 (4M x 16) <b>or</b> ■ 4 (8M x 16)
■ 32 MB	■ 4 (4M x 16)

RAID SYSTEM is normally supplied with 64MB (PA-08P/SA-08P) and 128MB (SA-16P/PA-16P) DRAM installed.

**Note**

*There's no set formula to determine how much cache memory to use, but as a general rule, a workstation, with mostly very large files, such as for audio or video editing and playback, graphics or CAD files, can benefit from a large cache. File servers, with multiple random access of varying file size, generally have little or no performance improvement with additional cache.*

## Hardware Installation Guide

---

### SODIMM specifications:(Applied on PA-08P/SA-08P, PA-16P/SA-16P)

Minimum	Recommended
■ 200-pin SDRAM SODIMM module (PC-200).	■ DDR
■ SODIMM, with or without parity	■ With Parity, for security
■ Minimum of one SODIMM with 64 MB. The memory card socket can support , 64, 128, 256 , 512 MB or 1GB of memory.	■ Minimum of 64MB. More memory (up to 1GB) equals better performance: the size of the memory module defines the cache writing space available to the RAID SYSTEM.

### Architecture of supported SODIMM:

SDRAM Architecture	
■ 1GB	■ 16 (64M bit x 8)
■ 512 MB	■ 16 (32M bit x 8), 8 (32M bit x 16) <b>or</b> ■ 8 (64M bit x 8)
■ 256MB	■ 16 (16M bit x 8), 8 (32M bit x8), 8 (16M bit x 8) <b>or</b> ■ 4 (32M bit x 16)
■ 128 MB	■ 8 (16M bit x 8), 8 (8M bit x 16) <b>or</b> ■ 4 (16M bit x 16) , 16 (8M bit x8)
■ 64 MB	■ 4 (8M bit x 16) , 8 (8M bit x8)

## Installing SODIMM

To install a SODIMM, ensure the system is power off and disconnected. Then:

1. Unscrews three fasteners.
2. Remove the daughter board.
3. Insert a memory card at a 45-degree angle into the memory card socket so that the gold teeth of the card are no longer visible.
4. Press the card down firmly until the latches lock it into place.

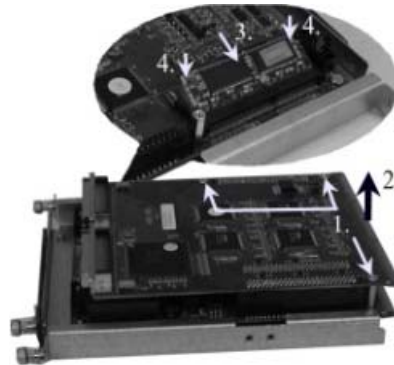

### Caution

*Before starting any kind of hardware installation, please ensure that all power switches have been turned off and all power cords disconnected to prevent personal injury and damage to the hardware*



### Caution

*Use screws provided with RAID system only. Longer or shorter screws may cause electric shorting or un-proper installed.*



### Caution

*Static electricity can damage electronic components. To guard against such damage:*

*Work in a static-free environment*

*Wear a grounded anti-static wrist strap*

*Store uninstalled components in anti-static bags*

*Handle PCBs by their edges and avoid touching chips and connectors.*

### Hot Swapping to replace the Fan Module

This section provides instructions for the removal and installation of the Fan Module indicated in the figure below.

SA-16/PA-16/PA-08

BR-8000/BR-1200  
BR-1600

#### Removing the Fan Module from RAID system :

Remove the Fan modules by anti-clock wise to release the thumb screw then slide it back and lifting off.

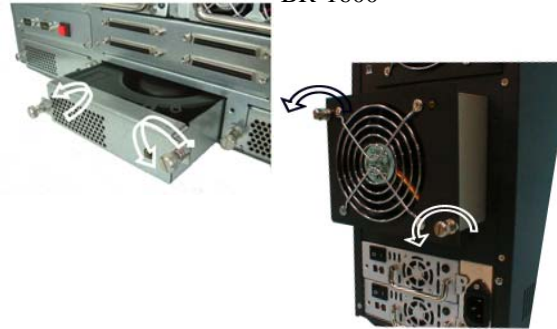

#### Installing the Fan module into RAID system :

Insert a Fan module then fasten the thumb screw clock wise .

## Hot Swapping to replace the Power Module

This section provides instructions for the removal and installation of the Fan Module indicated in the figure below.

### Removing the Power Module from RAID system PA-08 :

Unscrew the fastener then slide it back and lifting off.



### Removing the Power Module from RAID system BR-8000 :

Unscrew the fastener then slide it back and lifting off.



### Removing the Power Module from RAID system SA-16/PA-16 :

Unscrew the fastener then slide it back and lifting off.



### Removing the Power Module from RAID system BR-1200/1600 :

Unscrew the fastener then slide it back and lifting off.



### Installing the Power module into RAID system :

Insert a Power module then fasten the screw.



#### Note

*The Power indicator will turn bright "Green" to indicate it has powered on*

### **Turning on for the first time**

When cabling is completed, RAID SYSTEM can be turned on. This should be done in the following order:

1. First turn on the power switch of RAID SYSTEM.
2. Then power on and boot the host computer(s)

When RAID SYSTEM is running, you are ready to configure one or more RAID arrays. You have the following options:

1. Turn to Chapter 3 of “Software Operation Manual” to perform a quick setup of a single RAID array using the control panel.
2. Turn to Chapter 4 of “Software Operation Manual” to access the Monitor Utility. Once the Monitor Utility is accessed, you can perform a Quick Setup (Chapter 3) or complete configuration (Chapter 5) with either the control panel or Monitor Utility.
3. Turn to Chapter 5 of “Software Operation Manual” to perform a full configuration using the control panel.

### **Turning off**

When turning off RAID SYSTEM, users are advised to first shut down the server, then power off RAID SYSTEM.

### **Restarting**

When restarting RAID SYSTEM, users are advised to first restart the server, then power on RAID SYSTEM.



## Appendix A

# Trouble Shooting

### Problems setting up

Newly installed memory fails during Self-Test or is not detected.

Possible Cause: The Memory SO-DIMM module may not be properly seated or may not be supported by RAID SYSTEM.

Fix: Re-sit the memory module in the socket and retry. If it continues to fail try moving it to the other memory socket. Make sure the correct memory type is being installed. RAID SYSTEM supports 144-pin SO-DIMM SDRAM.

Unable to access RAID SYSTEM after the operating system boots up.

Possible Cause: RAID SYSTEM is not configured.

Fix: Make sure RAID SYSTEM is configured for a RAID level. If no RAID level is configured the operating system will not detect RAID SYSTEM as a disk drive.

RAID SYSTEM does not recognize the HDDs

Possible Cause: HDD jumper setting problem.

Fix: Make sure all drive jumpers are set to "master"

I try to set up an array using Quick Setup but fail. Why?

Possible Cause: If the error message Array1 Exists! appears, an array has already been configured. Quick Setup can only be used to new RAID arrays.

Fix: Reconfigure the array from the RAID params submenu

### Problems during operation

The front panel LCD displays alternating "Zz" characters.

Possible Cause: These characters are displayed when the cache is full with write request data that have not been processed. Requests from the host are halted to flush the data in the cache.

Fix: None needed.

The front panel LCD displays alternating "Ww" characters.

Possible Cause: These characters are displayed to indicate that write requests in the cache are

## Hardware Installation Guide

---

being processed. When these characters are displayed, RAID SYSTEM will halt requests from the host (see above).

Fix: Make sure the *Write Buffer* option of the *RAID Params* menu is enabled. In addition, more cache memory may be required. By increasing the cache memory, the write buffer space increases and will be able to handle the higher write requests.

LCD display shows OWOOOS

Possible Cause: “W” means “warning” - there are many bad sectors on your HDD.

Fix: Change hard drives.

Invalid NVRAM message appears

Possible Cause: NVRAM error or malfunction.

Fix: Save settings and restart the controller. If the problem persists, contact your vendor.

Data loss for Windows 2000 during system shutdown

Possible Cause: RAID controller is in a process of a built-in host and some data is still in cache buffer during system shutdown.

Fix 1: Set *Cache Off*

Fix 2: To shutdown, select *Restart system* and wait for 30 seconds, then power off the system.

Fix 3: Shutdown host OS after shutting down controller.

## Remote terminal problems

Unable to access Configuration Mode using the remote terminal interface.

Possible Cause 1: The terminal communication settings do not match the settings of the RAID SYSTEM RS-232 interface.

Fix: The default settings for the RS-232 port are 19,200 Baud rate, 8 Data bits, 1 Stop bit, No Parity, and XON/XOFF Flow control. Make sure the terminal is configured for these settings. If the settings were changed in Configuration Mode, verify the settings of the RAID SYSTEM in the RS-232 Params, Terminal option and change the terminal settings accordingly.

Possible Cause 2: Incompatible RS232 cable.

Fix: Cross pins on the RS-232 cable as shown below (or use a null modem cable). The only pins used are 2 3 & 5.

**1 2 3 4 5 6 7 8 9**  
**X I**  
**1 2 3 4 5 6 7 8 9**

### Alert message problems

I am unable to send a Page or FAX using the modem port.

Possible Cause 1: The Page and Fax options are not enabled.

Fix: Go to the Configuration Mode and enable Page and FAX notification via the System Params menu option.

Possible Cause 2: The default modem initialization string is not compatible with your modem.

Fix: Change the modem initialization string in the System Params option. Refer to your modem manual for its initialization string.

The following modem models require their own initialization strings.

Modem Model	Initialization String	Baud Rate	FAX Class
Motorola ModemSURFR V.34 28.8	AT&D\Q1E	Up to 38400	1 & 2
Multitech Multimodem 2834ZDX	AT&D0&E5E0	Up to 38400	2 only
Hayes Accura 288 V.34+FAX	AT&D0&K4E0	38400 only	1 & 2
Practical Peripherals PM144MT II	AT&K4	Up to 38400	2 only
GVC F-1128V/T2	AT&D0&B1&H2	38400 only	1 & 2
US Robotics Sportster 28800	AT&H2&I1&R1&B1	38400 only	1 only

### SCSI problems

RAID SYSTEM is not properly identified by the SCSI adapter during initialization of the computer system.

Possible Cause: The SCSI ID set for the RAID SYSTEM is being used by another SCSI device attached to the same SCSI card.

Fix: Select the Set SCSI ID option from the SCSI Params menu and specify a different SCSI ID. Most SCSI host adapters provide an onboard ROM BIOS, or software utility, that displays the devices attached and their SCSI IDs. Disconnect RAID SYSTEM from the SCSI host adapter card and during the system boot, or by running the utility, note the SCSI IDs already in use.

The RAID SYSTEM is identified as all SCSI IDs.

Possible Cause: The SCSI ID set for RAID SYSTEM is identical to the reserved SCSI ID used by the SCSI card in your system.

Fix: Select the Set SCSI ID option from the SCSI Params menu and specify a different SCSI ID. Most SCSI host adapter cards reserve SCSI ID 7 for the card ID.

The SCSI host adapter card does not detect RAID SYSTEM.

Possible Cause: Incorrect termination in a daisy chain configuration or a loose cable in a stand-alone configuration.

Fix: In a daisy chain configuration, verify that only the SCSI host adapter and the last SCSI device is terminated. To change termination settings of RAID SYSTEM, use the SCSI Params menu SCSI Termination option to enable or disable termination.

Appendix B

Connectors

SCSI Connector

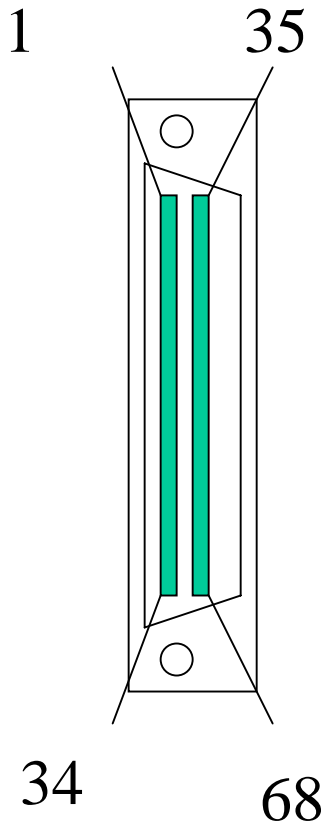

Pin#	Signal Name	Pin#	Signal Name
1	SCSI_AC_DAT<12>+	35	SCSI_AC_DAT<12>-
2	SCSI_AC_DAT<13>+	36	SCSI_AC_DAT<13>-
3	SCSI_AC_DAT<14>+	37	SCSI_AC_DAT<14>-
4	SCSI_AC_DAT<15>+	38	SCSI_AC_DAT<15>-
5	SCSI_AC_PAR<1>+	39	SCSI_AC_PAR<1>-
6	SCSI_AC_DAT<0>+	40	SCSI_AC_DAT<0>-
7	SCSI_AC_DAT<1>+	41	SCSI_AC_DAT<1>-
8	SCSI_AC_DAT<2>+	42	SCSI_AC_DAT<2>-
9	SCSI_AC_DAT<3>+	43	SCSI_AC_DAT<3>-
10	SCSI_AC_DAT<4>+	44	SCSI_AC_DAT<4>-
11	SCSI_AC_DAT<5>+	45	SCSI_AC_DAT<5>-
12	SCSI_AC_DAT<6>+	46	SCSI_AC_DAT<6>-
13	SCSI_AC_DAT<7>+	47	SCSI_AC_DAT<7>-
14	SCSI_AC_PAR<0>+	48	SCSI_AC_PAR<0>-
15	GND	49	GND
16	GND	50	GND
17	TERMPWRA	51	TERMPWRA
18	TERMPWRA	52	TERMPWRA
19	GND	53	GND
20	GND	54	GND
21	SCSI_AC_ATN_L+	55	SCSI_AC_ATN_L-
22	GND	56	GND
23	SCSI_AC_BSY_L+	57	SCSI_AC_BSY_L-
24	SCSI_AC_ACK_L+	58	SCSI_AC_ACK_L-
25	SCSI_AC_RST_L+	59	SCSI_AC_RST_L-
26	SCSI_AC_MSG_L+	60	SCSI_AC_MSG_L-
27	SCSI_AC_SEL_L+	61	SCSI_AC_SEL_L-
28	SCSI_AC_CD_L+	62	SCSI_AC_CD_L-
29	SCSI_AC_REQ_L+	63	SCSI_AC_REQ_L-
30	SCSI_AC_IO_L+	64	SCSI_AC_IO_L-
31	SCSI_AC_DAT<0>+	65	SCSI_AC_DAT<0>-
32	SCSI_AC_DAT<9>+	66	SCSI_AC_DAT<9>-
33	SCSI_AC_DAT<10>+	67	SCSI_AC_DAT<10>-
34	SCSI_AC_DAT<11>+	68	SCSI_AC_DAT<11>-

### FC-AL HSSDC. Connector

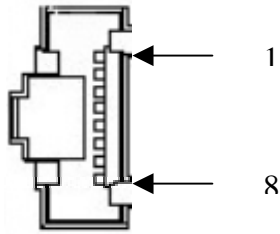

Pin#	Signal Name
1	TX+
2	Ground
3	TX-
4	Fault-
5	ODIS
6	RX-
7	+5VDC
8	RX+

### RS-232 & Modem Male Connector

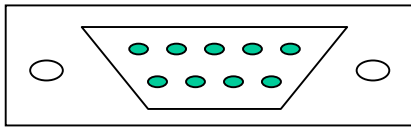

Pin#	Signal	Pin#	Signal
1	DCD	6	DSR
2	RXD	7	RTS
3	TXD	8	CTS
4	DTR	9	TXC
5	GND		

## Appendix C

## Specifications

## SA-16U4P/FCP

Model	SA-16P	
	U4	FC
<b>RAID Engine</b>	Intel i80321 64bit RISC CPU	
<b>RAID Levels</b>	0, 1, 3, 5,30,50 or 0+1	
<b>Cache Support (Write back)</b>	Up to 1GBMbytes with ECC 200pins DDRAM Memory	
<b>System Type</b>	Rack mountable	
<b>Host Interface</b>	Dual Ultra 320 SCSI Channels	Dual loops 2Gb Fibre Channels, Standard SFP connectors
<b>Host Transfer Rate</b>	320MB / Sec per channel	2Gb/ Sec per loop
<b>Disk Interface</b>	SATA 1.5Gbps	
<b>Disk Channel</b>	Sixteen SATA 1.5Gb Disk Channels	
<b>LCD Display</b>	2 Lines by 16 Characters	
<b>Hot Swap and redundant</b>	Yes (Power Supply, Drive and Fan).	
<b>Hot Spare</b>	Yes (Drive).	
<b>Battery Back-Up Module</b>	<b>Optional</b> , Support up to 72hrs battery back-up time (N.A.)	
<b>UART – LAN</b>	<b>Optional</b> , Window-Based GUI RAID manager designed for SCSI/FC host based RAID solutions. The OS-independent, cross-platform RAID management allows configuration and status monitoring via standard web browsers or host computers either directly connected to a LAN or WAN.	
<b>FC bypass module</b>	<b>Optional</b> , Connecting each RAID systems with in-built FC hub adaptors, provides the greater extension availability, <b>No need extra External FC Hub or Switch.</b>	
<b>Array Management Support</b>	Yes.	
<b>Automatic Bad-Sector &amp; Error Recovery</b>	Yes.	
<b>Automatic Drive Rebuilds</b>	Yes. Automatic Data rebuilds.	
<b>Audible Alarm, Pager and Fax Notification</b>	Yes. The Pager and Fax Notification have to connect a external modem.	
<b>Remote Terminal Configuration</b>	Yes. Through RS-232 emulation terminal.	
<b>Operating Systems</b>	O/S Independent and Transparent	
<b>Power Supply</b>	700+350 watts Redundancy high quality power system, three 350 watts module with PFC function. Load sharing type and cable-less design with <b>Redundancy Dual Power inlet</b>	
<b>Electrical</b>	AC Voltage 100-240 VAC Ac Frequency 47-63Hz	
<b>Temperature</b>	Operating Temperature : 5 to 35 degree C. Non Operating Temperature : -40 to 60 degree C.	
<b>Relative Humidity</b>	20% to 80% non-condensing	
<b>Dimensions</b>	446.4(W)*440.4(D)*3U(H)	
<b>Weight</b>	28KG	

## Hardware Installation Guide

PA-16U4P/FCP

Model	SA-16P	
	U4	FC
<b>RAID Engine</b>	Intel i80321 64bit RISC CPU	
<b>RAID Levels</b>	0, 1, 3, 5,30,50 or 0+1	
<b>Cache Support (Write back)</b>	Up to 1GBMbytes with ECC 200pins DDRAM Memory	
<b>System Type</b>	Rack mountable	
<b>Host Interface</b>	Dual Ultra 320 SCSI Channels	Dual loops 2Gb Fibre Channels, Standard SFP connectors
<b>Host Transfer Rate</b>	320MB / Sec per channel	2Gb/ Sec per loop
<b>Disk Interface</b>	EIDE, ATA-100	
<b>Disk Channel</b>	Sixteen of UltraDMA100 Disk Channel	
<b>LCD Display</b>	2 Lines by 16 Characters	
<b>Hot Swap and redundant</b>	Yes (Power Supply, Drive and Fan).	
<b>Hot Spare</b>	Yes (Drive).	
<b>Battery Back-Up Module</b>	<b>Optional</b> , Support up to 72hrs battery back-up time (N.A.)	
<b>UART – LAN</b>	<b>Optional</b> , Window-Based GUI RAID manager designed for SCSI/FC host based RAID solutions. The OS-independent, cross-platform RAID management allows configuration and status monitoring via standard web browsers or host computers either directly connected to a LAN or WAN.	
<b>FC bypass module</b>	<b>Optional</b> , Connecting each RAID systems with in-build FC hub adaptors, provides the greater extension availability, <b>No need extra External FC Hub or Switch</b> .	
<b>Array Management Support</b>	Yes.	
<b>Automatic Bad-Sector &amp; Error Recovery</b>	Yes.	
<b>Automatic Drive Rebuilds</b>	Yes. Automatic Data rebuilds.	
<b>Audible Alarm, Pager and Fax Notification</b>	Yes. The Pager and Fax Notification have to connect a external modem.	
<b>Remote Terminal Configuration</b>	Yes. Through RS-232 emulation terminal.	
<b>Operating Systems</b>	O/S Independent and Transparent	
<b>Power Supply</b>	700+350 watts Redundancy high quality power system, three 350 watts module with PFC function. Load sharing type and cable-less design with <b>Redundancy Dual Power inlet</b>	
<b>Electrical</b>	AC Voltage 100-240 VAC Ac Frequency 47-63Hz	
<b>Temperature</b>	Operating Temperature : 5 to 35 degree C. Non Operating Temperature : -40 to 60 degree C.	
<b>Relative Humidity</b>	20% to 80% non-condensing	
<b>Dimensions</b>	446.4(W)*493.6(D)*3U(H)	
<b>Weight</b>	28KG	



SA-16U3/FC

Model	SA-16	
	U3	FC
<b>RAID Engine</b>	Intel i80303 64bit RISC CPU	
<b>RAID Levels</b>	0, 1, 3, 5 or 0+1	
<b>Cache Support (Write back)</b>	Up to 512Mbytes with ECC 144pins SDRAM Memory	
<b>System Type</b>	Rack mountable	
<b>Host Interface</b>	Dual Ultra 160 SCSI Channels	Dual loops 2Gb Fibre Channels, Standard SFP connectors
<b>Host Transfer Rate</b>	160MB / Sec per channel	2Gb/ Sec per loop
<b>Disk Interface</b>	SATA 1.5Gbps	
<b>Disk Channel</b>	Sixteen SATA 1.5Gb Disk Channels	
<b>LCD Display</b>	2 Lines by 16 Characters	
<b>Hot Swap and redundant</b>	Yes (Power Supply, Drive and Fan).	
<b>Hot Spare</b>	Yes (Drive).	
<b>Battery Back-Up Module</b>	<b>Optional</b> , Support up to 72hrs battery back-up time (N.A.)	
<b>UART – LAN</b>	<b>Optional</b> , Window-Based GUI RAID manager designed for SCSI/FC host based RAID solutions. The OS-independent, cross-platform RAID management allows configuration and status monitoring via standard web browsers or host computers either directly connected to a LAN or WAN.	
<b>FC bypass module</b>	<b>Optional</b> , Connecting each RAID systems with in-built FC hub adaptors, provides the greater extension availability, <b>No need extra External FC Hub or Switch</b> .	
<b>Array Management Support</b>	Yes.	
<b>Automatic Bad-Sector &amp; Error Recovery</b>	Yes.	
<b>Automatic Drive Rebuilds</b>	Yes. Automatic Data rebuilds.	
<b>Audible Alarm, Pager and Fax Notification</b>	Yes. The Pager and Fax Notification have to connect a external modem.	
<b>Remote Terminal Configuration</b>	Yes. Through RS-232 emulation terminal.	
<b>Operating Systems</b>	O/S Independent and Transparent	
<b>Power Supply</b>	700+350 watts Redundancy high quality power system, three 350 watts module with PFC function. Load sharing type and cable-less design with <b>Redundancy Dual Power inlet</b>	
<b>Electrical</b>	AC Voltage 100-240 VAC Ac Frequency 47-63Hz	
<b>Temperature</b>	Operating Temperature : 5 to 35 degree C. Non Operating Temperature : -40 to 60 degree C.	
<b>Relative Humidity</b>	20% to 80% non-condensing	
<b>Dimensions</b>	446.4(W)*440.4(D)*3U(H)	
<b>Weight</b>	28KG	

## Hardware Installation Guide

### PA-16U3/FC PA-08U3/FC

Model	PA-16		PA-08	
	U3	FC	U3	FC
<b>RAID Engine</b>	Intel i80303 64bit RISC CPU			
<b>RAID Levels</b>	0, 1, 3, 5 or 0+1			
<b>Cache Support (Write back)</b>	Up to 512Mbytes with ECC 144pins SDRAM Memory			
<b>System Type</b>	Rack mountable			
<b>Host Interface</b>	Dual Ultra 160 SCSI Channels	Dual loops 2Gb Fibre Channels, Standard SFP connectors	Dual Ultra 160 SCSI Channels	Dual loops 2Gb Fibre Channels, Standard SFP connectors
<b>Host Transfer Rate</b>	160MB / Sec per channel	2Gb / Sec per loop	160MB / Sec per channel	2Gb/ Sec per loop
<b>Disk Interface</b>	EIDE, ATA-100			
<b>Disk Channel</b>	Sixteen of UltraDMA100 Disk Channel		Eight of UltraDMA100 Disk Channel	
<b>LCD Display</b>	2 Lines by 16 Characters			
<b>Hot Swap and redundant</b>	Yes (Power Supply, Drive and Fan).			
<b>Hot Spare</b>	Yes (Drive).			
<b>Battery Back-Up Module</b>	<b>Optional</b> , Support up to 72hrs battery back-up time (N.A.)			
<b>UART – LAN</b>	<b>Optional</b> , Window-Based GUI RAID manager designed for SCSI/FC host based RAID solutions. The OS-independent, cross-platform RAID management allows configuration and status monitoring via standard web browsers or host computers either directly connected to a LAN or WAN.			
<b>FC bypass module</b>	<b>Optional</b> , Connecting each RAID systems with in-build FC hub adaptors, provides the greater extension availability, <b>No need extra External FC Hub or Switch</b> .			
<b>Array Management Support</b>	Yes.			
<b>Automatic Bad-Sector &amp; Error Recovery</b>	Yes.			
<b>Automatic Drive Rebuilds</b>	Yes. Automatic Data rebuilds.			
<b>Audible Alarm, Pager and Fax Notification</b>	Yes. The Pager and Fax Notification have to connect a external modem.			
<b>Remote Terminal Configuration</b>	Yes. Through RS-232 emulation terminal.			
<b>Operating Systems</b>	O/S Independent and Transparent			
<b>Power Supply</b>	<b>PA-16:</b> 750+375 watts Redundancy high quality power system, three 375 watts module with PFC function. Load sharing type and cableless design with <b>Redundancy Dual Power inlet</b> <b>PA-08:</b> 700+350 watts Redundancy high quality power system, two 350 watts module with PFC function. Load sharing type.			
<b>Electrical</b>	AC Voltage 100-240 VAC Ac Frequency 47-63Hz			
<b>Temperature</b>	Operating Temperature : 5 to 35 degree C. Non Operating Temperature : -40 to 60 degree C.			
<b>Relative Humidity</b>	20% to 80% non-condensing			
<b>Dimensions</b>	446.4(W)*493.6(D)*3U(H)		445.4(W)*538.8(D)*2U(H)	
<b>Weight</b>	28KG		19KG	

## BR-8000U3p/BR-8000FCp

	<b>Fibre –IDE RAID</b>	<b>U3 SCSI – IDE RAID</b>
	<b>BR-8000FCp-D</b>	<b>BR-8000U3p-D</b>
	<b>BR-8000FCp-R</b>	<b>BR-8000U3p-R</b>
<b>RAID Engine</b>	Intel i80303 64bit RISC CPU	
<b>RAID Levels</b>	0, 1, 3, 5 or 0+1	
<b>Cache Support (Write back)</b>	64Mbytes, up to 512Mbytes with ECC 144pins SDRAM Memory	
<b>System Type</b>	<b>DeskSide</b>	<b>DeskSide</b>
	<b>Rackmount</b>	<b>Rackmount</b>
<b>Host Interface</b>	Dual Loop of 2Gbit Fibre Channel (FC-AL), SFP connectors	Dual Ultra 3 (Ultra 160) SCSI
<b>Host Transfer Rate</b>	2Gb/sec per Loop	160Mb/Sec per Channel
<b>Disk Interface</b>	ATA100 EIDE	
<b>Disk Channel</b>	Eight of UltraDMA100 Disk Channel	
<b>Drive Bay Feature</b>	8 Removable Units	
<b>FC-AL ID Assignment</b>	0-125, Software Configuration.	
<b>SCSI ID Assignment</b>		0 –15, Software Configuration
<b>LCD Display</b>	2 Lines by 16 Characters	
<b>Hot Swap</b>	Yes (Power Supply, Drive and Fan).	
<b>Hot Spare</b>	Yes (Drive).	
<b>Select Strip Size</b>	Yes (128, 64, 32, 16, 8 or 4 blocks) ( 1 block = 512 Bytes)	
<b>Automatic Bad-Sector &amp; Error Recovery</b>	Yes.	
<b>Automatic Drive Rebuilds</b>	Yes. Automatic Data rebuilds.	
<b>Audible Alarm, Pager and Fax Notification</b>	Yes. The Pager and Fax Notification have to connect a external modem.	
<b>Remote Terminal Configuration</b>	Yes. Through RS-232 emulation terminal.	
<b>Operating Systems</b>	O/S Independent and Transparent	
<b>Power Supply</b>	Redundant by Dual 3750W Power modules, Load Sharing type.	
<b>Electrical</b>	AC Voltage 110-230 VAC Ac Frequency 50-60Hz	
<b>Temperature</b>	Operating Temperature : 10 to 35 degree C.	
<b>Relative Humidity</b>	20% to 80% non-condensing	
<b>Dimensions</b>	Desk side 179mm(W) x 366mm(D) x 424mm(H) Rackmount 482mm(W) x 570mm(D) x 3U	
<b>Weight</b>	15Kg(W/O Disk Drives) 18Kg	

## Hardware Installation Guide

### BR-1200U3p/BR-1200FCp

	BR-1200U3p-D	BR-1200U3p-R	BR-1200FCp-D	BR-1200FCp-R
<b>RAID Engine</b>	Intel i80303 64bit RISC CPU			
<b>RAID Levels</b>	0, 1, 3, 5 or 0+1			
<b>Cache Support (Write back)</b>	128Mbytes as the standard, up to 256Mbytes with ECC 144pins SDRAM Memory			
<b>System Type</b>	<b>Deskside</b>	<b>4U Rackmount</b>	<b>Deskside</b>	<b>4U Rackmount</b>
<b>Host Interface</b>	Dual Ultra160 SCSI channels		Dual loops of 2Gbit Fibre channel, SFP connectors	
<b>Host Transfer Rate</b>	160MB/sec per channel		2Gb/sec per Loop	
<b>Disk Interface</b>	EIDE, ATA-100			
<b>Disk Transfer Rate</b>	Up to 100Mbyte/disk.			
<b>Disk Channel</b>	Twelve of UltraDMA133 Disk Channel			
<b>LCD Display</b>	2 Lines by 16 Characters			
<b>Hot Swap and redundant</b>	Yes (Power Supply, Drive and Fan).			
<b>Hot Spare</b>	Yes (Drive).			
<b>Array Management Support</b>	Yes.			
<b>Multiple RAID Support</b>	Yes			
<b>Automatic Bad-Sector &amp; Error Recovery</b>	Yes.			
<b>Automatic Drive Rebuilds</b>	Yes. Automatic Data rebuilds.			
<b>Audible Alarm, Pager and Fax Notification</b>	Yes. The Pager and Fax Notification have to connect a external modem.			
<b>Remote Terminal Configuration</b>	Yes. Through RS-232 emulation terminal.			
<b>Operating Systems</b>	O/S Independent and Transparent			
<b>Power Supply</b>	Redundant of three of 300W Power modules with PFC function, Load Sharing type. Hi quality power module, cableless design			
<b>Electrical</b>	AC Voltage 100-240 VAC Ac Frequency 47-63Hz			
<b>Temperature</b>	Operating Temperature : 5 to 35 degree C. Non Operating Temperature : -40 to 60 degree C.			
<b>Relative Humidity</b>	20% to 80% non-condensing			
<b>Dimensions</b>	195(W) x 495(D) x 450(H) 19" (W) x 495(D) x 4U			
<b>Weight</b>	28.0Kg(W/O Disk Drives)			

**BR-1600U3p/BR-1600FCp**

	<b>BR-1600U3p-D</b>	<b>BR-1600U3p-R</b>	<b>BR-1600FCp-D</b>	<b>BR-1600FCp-R</b>
<b>RAID Engine</b>	Intel i80303 64bit RISC CPU			
<b>RAID Levels</b>	0, 1, 3, 5 or 0+1			
<b>Cache Support (Write back)</b>	128Mbytes as the standard, up to 512Mbytes 144pins SDRAM Memory ( ECC supported)			
<b>System Type</b>	<b>Deskside</b>	<b>4U Rackmount</b>	<b>Deskside</b>	<b>4U Rackmount</b>
<b>Host Interface</b>	Dual Ultra160 SCSI channels		Dual loops of 2Gbit Fibre channel, SFP connectors	
<b>Host Transfer Rate</b>	160MB/sec per channel		2Gb/sec per Loop	
<b>Disk Interface</b>	EIDE, ATA-100.			
<b>Disk Transfer Rate</b>	Up to 100Mbyte/disk.			
<b>Disk Channel</b>	Sixteen of UltraDMA100 Disk Channel			
<b>LCD Display</b>	2 Lines by 16 Characters			
<b>Hot Swap and redundant</b>	Yes (Power Supply, Drive and Fan).			
<b>Hot Spare</b>	Yes (Drive).			
<b>Array Management Support</b>	Yes.			
<b>Multiple RAID Support</b>	Yes			
<b>Automatic Bad-Sector &amp; Error Recovery</b>	Yes.			
<b>Automatic Drive Rebuilds</b>	Yes. Automatic Data rebuilds.			
<b>Audible Alarm, Pager and Fax Notification</b>	Yes. The Pager and Fax Notification have to connect a external modem.			
<b>Remote Terminal Configuration</b>	Yes. Through RS-232 emulation terminal.			
<b>Operating Systems</b>	O/S Independent and Transparent			
<b>Power Supply</b>	Redundant of three of 375W Power modules with PFC function, Load Sharing type. Hi quality power module, cableless design			
<b>Electrical</b>	AC Voltage 100-240 VAC Ac Frequency 47-63Hz			
<b>Temperature</b>	Operating Temperature : 5 to 35 degree C. Non Operating Temperature : -40 to 60 degree C.			
<b>Relative Humidity</b>	20% to 80% non-condensing			
<b>Dimensions</b>	195(W) x 495(D) x 455(H) 19" (W) x 495(D) x 4U			
<b>Weight</b>	BR-1600-R : 28.0Kg, BR-1600-D : 35Kg (W/O Disk Drives)			



### Note

*\*Specification subject to change without notice, all trademarks or registered trademarks are properties of their respective owners.*